

FIO 3.0

Smart Gas Grid



TECHNICAL BROCHURE

Pietro Fiorentini S.p.A.

Via E.Fermi, 8/10 | 36057 Arcugnano, Italy | +39 0444 968 511
sales@fiorentini.com

The data are not binding. We reserve the right
to make changes without prior notice.

FIO3-0_technicalbrochure_ENG_revB

www.fiorentini.com

Who we are

We are a global organization specialized in designing and manufacturing technologically advanced solutions for natural gas treatment, transmission and distribution systems.

We are the ideal partner for operators in the Oil & Gas sector, with a business offer that goes across the whole natural gas chain.

We are in constant evolution to meet our customers' highest expectations in terms of quality and reliability.

Our aim is to be a step ahead of the competition, with customized technologies and an after-sale service program undertaken with the highest grade of professionalism.



Pietro Fiorentini advantages



Localised technical support



Experience since 1940



We operate in over 100 countries



Area of Application

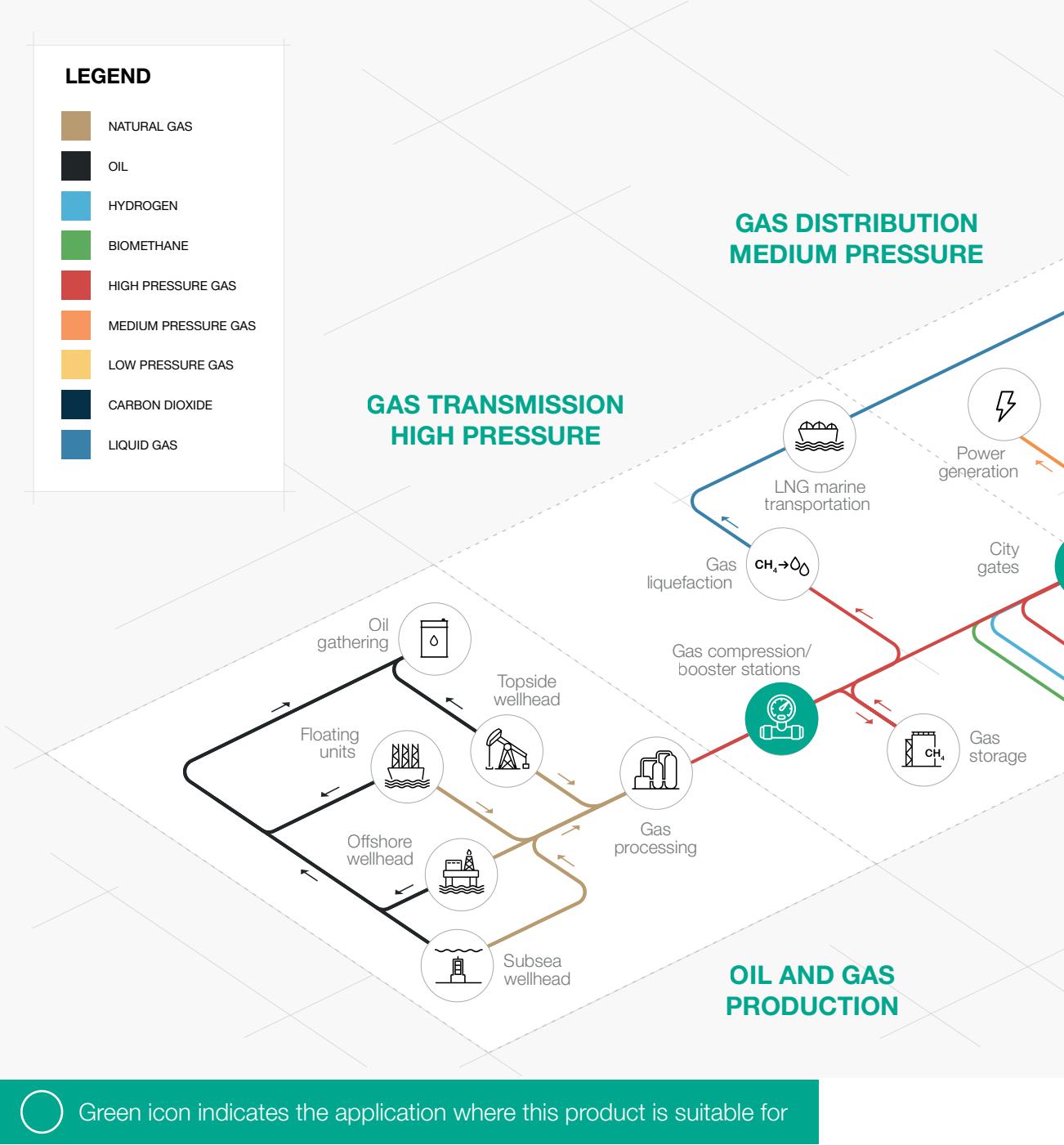

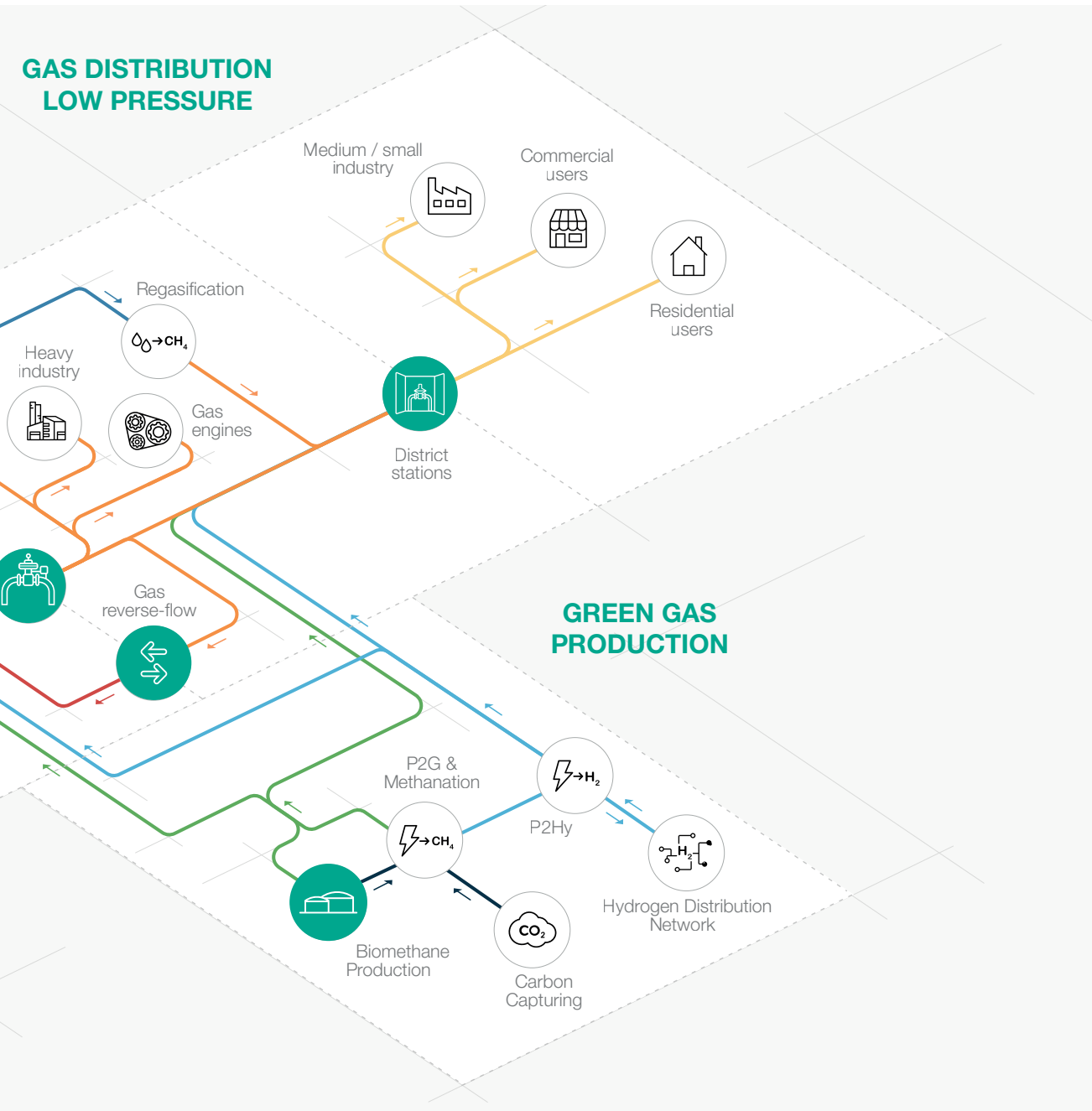

Figure 1 Area of application map



FIONet
FIO 3.0

The FIO 3.0 is a modular system designed for the remote control of **pressure reduction stations** within **natural gas distribution networks**. Its modular architecture, scalability, and ease of customization make it an ideal solution for both standard and complex applications, enabling the digitization and automation of pressure regulation processes.

The solution is based on Starbox LX2 RTUs and, even in its basic configuration, is able to meet the installation requirements of highly complex stations. The system comes in standard DL (Dual Line) and QL (Quad Line) versions and, on request, can be expanded with additional digital and analog I/O interfaces.

Features and advantages



Non-intrusive flow measurement

Indirect Flow Measurement (IFM) eliminates the need to installing a measuring device making it easy to integrate into existing pressure regulation stations.



Optimized gas pressure management

Through pressure profiling, the system ensures gas is delivered at the correct pressure throughout the network, reducing overpressure risks and minimizing gas leakages.



Dynamic pressure compensation

Automatically adjusts the outlet pressure based on gas consumption, ensuring supply reliability and improving system efficiency.



Remote control and monitoring

Operators can adjust pressure set points, receive real-time alerts, and take corrective actions remotely, significantly reducing the need for on-site interventions.



Enhanced safety features

The system can automatically trip slam-shut valves or reduce pressure in case of critical conditions, preventing safety risks and protecting infrastructure.



Comprehensive data collection and analysis

Integrates multiple sensors to monitor parameters like pressure, temperature, filter clogging, facility access, seismic activity, and environmental conditions, providing a complete view of system performance.



Improved regulatory compliance and equipment performance

Precise flow rate regulation prevents equipment from exceeding performance limits, ensuring compliance with technical and contractual requirements while optimizing meter and regulator accuracy.



Cost savings and operational efficiency

By minimizing the need for manual interventions and enabling real-time remote adjustments, the FIO 3.0 reduces operational costs and enhances overall system reliability.

Typical use cases

Existing installation

The FIO 3.0 can be integrated on existing installations. An example of such a setup includes a regulation line positioned in the hazardous area and an electrical panel located in the safe area.

The existing pilots in both regulation lines have been replaced with corresponding magnetic pilots, which are integrated with the FIO 3.0 control panel.

All other installed components remain unchanged, minimizing the overall impact of the intervention.

Pressure reduction line with Pietro Fiorentini regulators



Figure 2

New Starbox control panel and old existing electrical panel

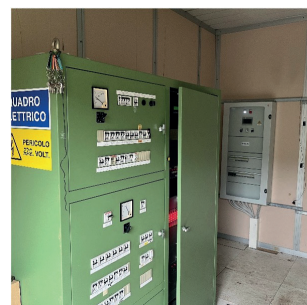

Figure 3



Below there are additional examples of FIO 3 applications on existing lines.

FIO 3.0 required for managing pressure and flow based on time-of-day intervals.

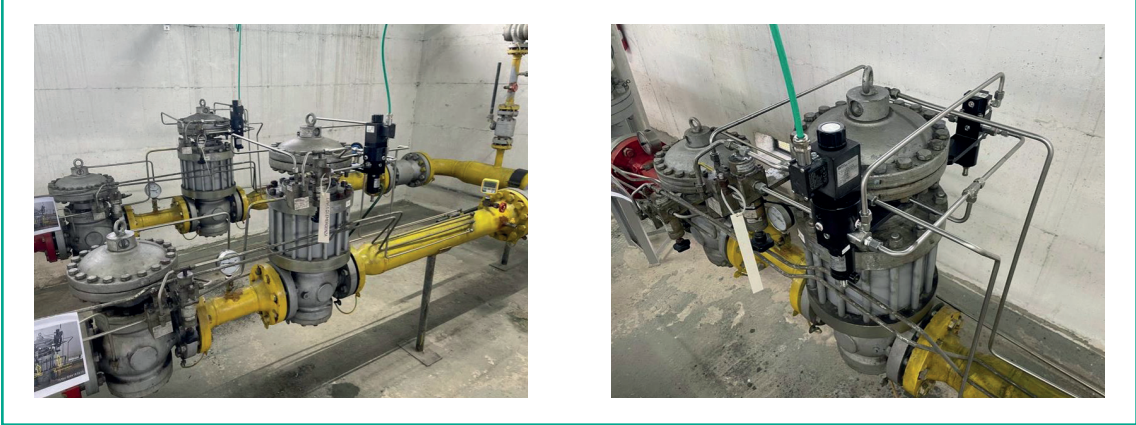

Figure 4

FIO 3.0 required to perform equal flow distribution across three lines simultaneously. It offers highly precise regulation and line swapping.

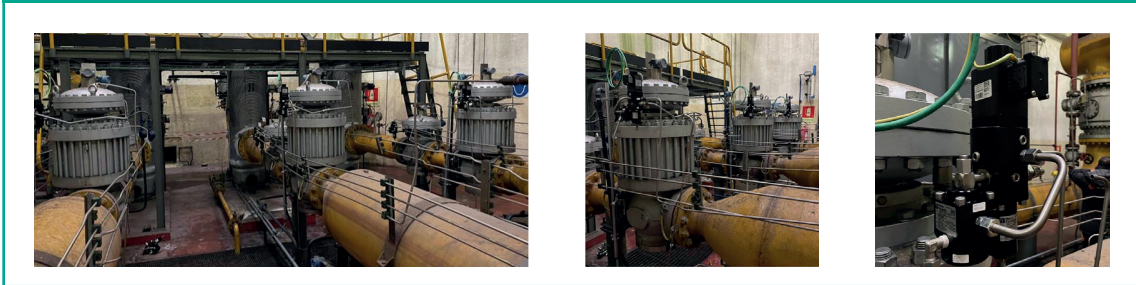

Figure 5

Brand new digital station

The FIO 3.0 can be easily implemented in brand-new stations, such as biomethane upgrading/injection plants and natural gas PRMS distribution stations.



Figure 6 Biogas (RNG) upgrading and injection stations

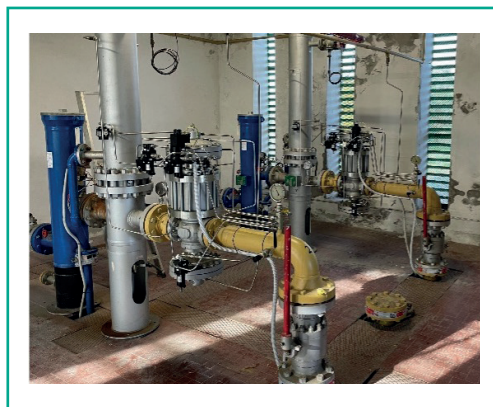

Figure 7 Methane gas distribution PRMS



FIO 3

Core functionalities

The **FIO 3.0** offers **versatile configurations** tailored to different applications, ensuring optimal performance and adaptability.

Whether it's indirect flow measurement, remote pressure control, remote monitoring, flow control, or remote disconnection, the FIO 3.0 provides a **reliable** and **scalable solution** to meet different operational needs.

The following diagram shows the core functionalities of the FIO 3.0 System.

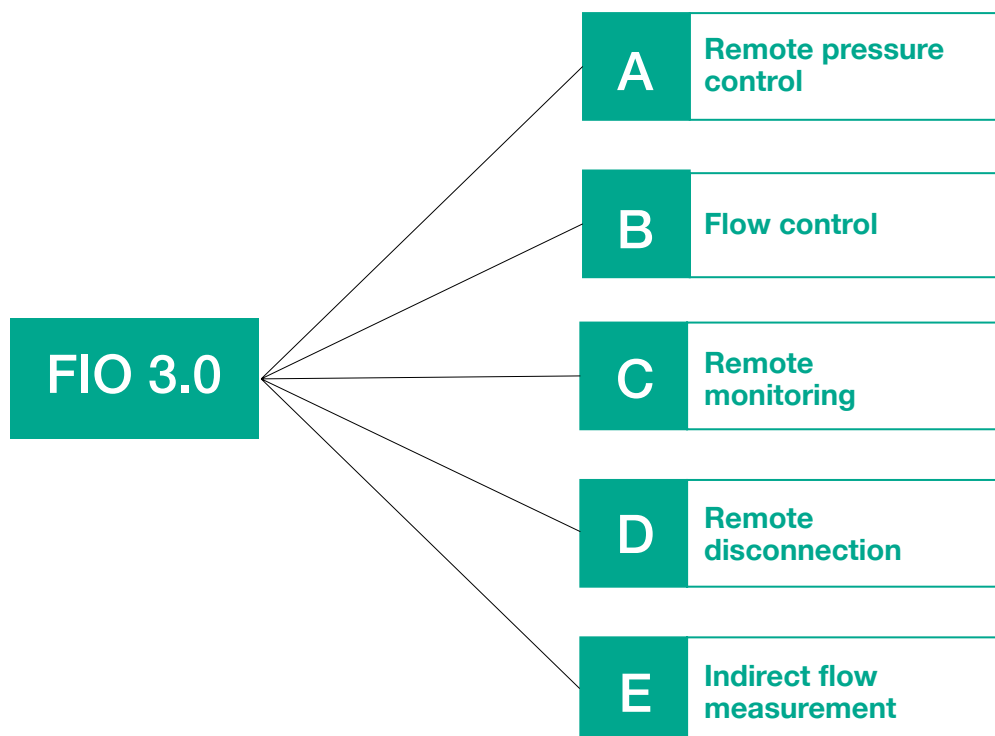

Figure 8 FIO 3.0 core functionalities

FIO 3

Hardware configurations

Below, a summary table outlining the available configurations of the FIO 3.0.

The table provides a **clear overview** of the **components required for each application**, ensuring seamless integration and customization based on specific operational needs.

For a detailed technical information of these components, please refer to the end of this document.



		Starbox control panel	HMI 10" touch screen	Remote display (wifi)	Magnetic pilot* + PWM	Q-KIT	Primary meter	Down-stream pressure transmitter	Upstream pressure and additional sensors
									
A	Remote pressure control	✓	Recommended	Optional	✓	Optional	-	✓	-
B1	Flow limitation	✓	Recommended	Optional	✓	Optional	✓	✓	-
B2	Flow control	✓	Recommended	Optional	✓	Optional	✓	✓	-
B3	Multiple line flow splitting	✓	Recommended	Optional	✓	✓	✓	✓	-
C	Remote monitoring	✓	Recommended	Optional	-	✓	-	✓	✓
D	Remote disconnection	✓	Recommended	Optional	✓	Optional	-	✓	-
E	Indirect flow measurement	✓	Recommended	Optional	-	✓	-	✓	✓

Table 1 Components needed for each applications

*Zero gas emission into the atmosphere









A Remote pressure control

Advanced pressure and flow regulation techniques are critical for ensuring the safe and efficient delivery of gas through the network.

These systems, including **pressure profiling, pressure compensation, and remote command functionalities**, provide dynamic control and real-time monitoring, enabling a rapid response to varying demand while maintaining optimal operational conditions.

By continuously optimizing pressure and flow, they help prevent issues such as overpressure, leakage, and supply interruptions, ensuring both safety and reliability across the entire system.

-  Enhanced pressure control
-  Dynamic optimization of gas supply
-  Customizable pressure profiles
-  Real-time monitoring
-  High accuracy
-  Remote safety management

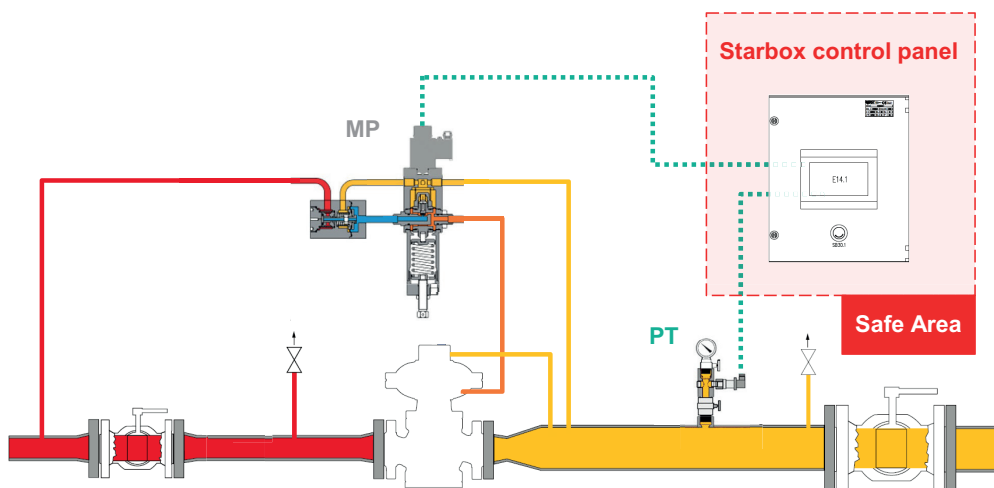

PT: pressure transmitter
MP: magnetic pilot

Figure 9 "Remote pressure control" application poster

Pressure profiling

The primary goal of pressure profiling is to **maintain the pressure within specified limits throughout the network**. This ensures that gas is delivered to consumers at the desired pressure, keeps up with gas demand, avoids overpressure and **minimizes gas leakage**. Pressure profiling is achieved by **automatically controlling** and changing the outlet pressure to **specific values over the course of the day**. Up to 7 different pressure set points can be configured for each timeslot. The module stores several weekly schedules.

Pressure compensation

Pressure compensation is used to **dynamically optimize the pressure** and **guarantee the gas supply**. This technique is used to define the correlation between the outlet pressure and the instant flow; up to 10 flow rate bands can be defined. Flow measurement is typically acquired either from a primary meter (Turbine, Rotary, Ultrasonic, ...) or a flow computer. The pressure modulation accuracy for the pressure profiling and pressure compensation is better than 1% of the nominal full range pressure value.

Remote command

The set point value is set remotely from the Central Control Software (CCS) or manually; the **operator is notified in real time** on diagnostic and status information. In case of particular conditions that could compromise the safety and operation of your system, **gas supply can be interrupted** by remotely tripping the slum-shut valve or **can be reduced** to a safe minimum level by remotely changing the set point. Restoring the operating condition usually requires an operator or technician on-site to identify and eliminate the source of the problem.

What you need?

- Starbox control panel
- 200/MP series or 300/MP series magnetic pilots
- Downstream pressure transmitter

Focus on the magnetic pilot

The pilot series 200/MP and 300/MP are an electro-mechanical device which **enables remote setpoint modifications** of pilot operated gas pressure regulators.

Furthermore, the pilot **optimizes the accuracy and lock-up performances thanks to real-time pulse width modulation control**.

Series 200 it is suitable with Reval , Reflux, Reflux/FO*, Dixi, Terval/R, ASX/FO and ASX176 regulators while series 300 is for Aperflux, Aperval, Terval/A and, upon request, magnetic pilots they can be used with any brand with the same working principle.

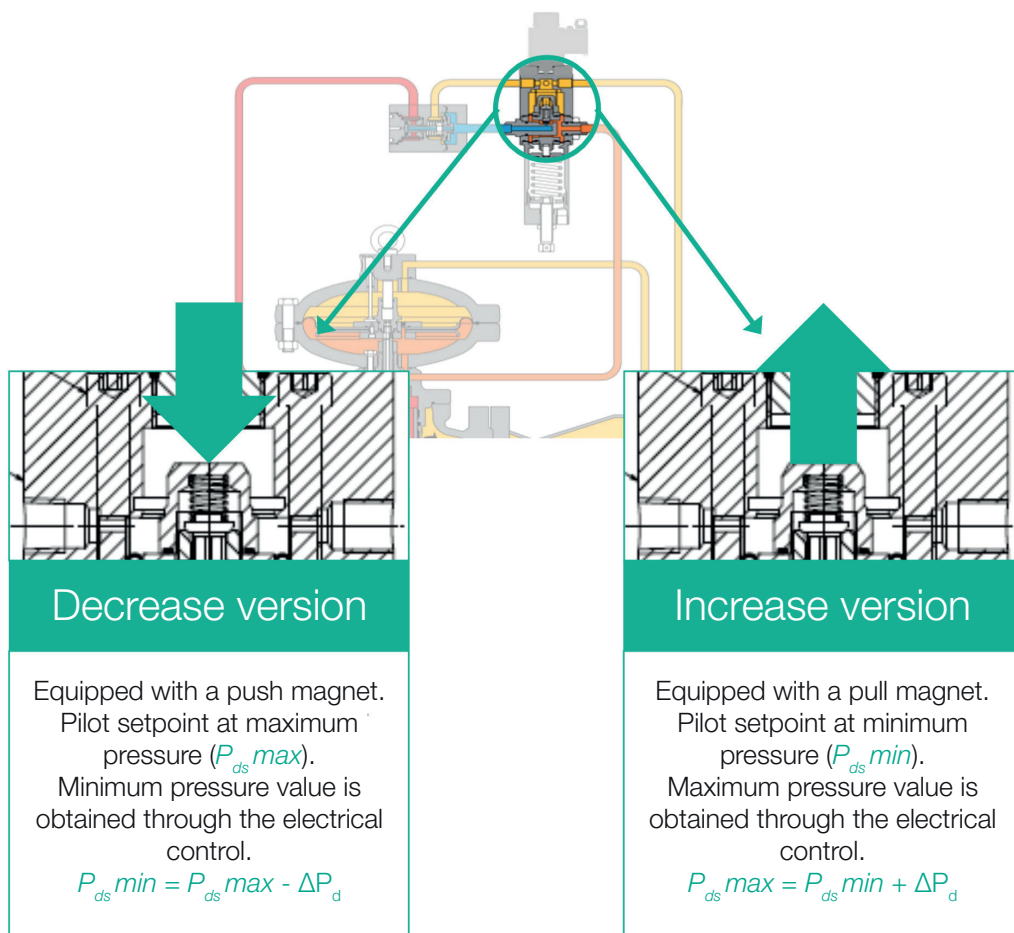

*For Reflux 819/FO is only available a decrease version for security reasons.

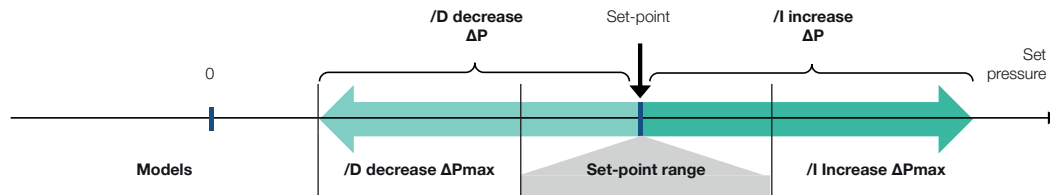

Models	/D decrease ΔP_{max}	Set-point range	/I Increase ΔP_{max}
201/MP + pre-reducer (R31)	16 kPa 160 mbarg	from 0.7 kPa to 58 kPa from 7 mbarg to 580 mbarg	12 kPa 120 mbarg
204/MP + pre-reducer (R14)	120 kPa 1.2 barg	from 20 kPa to 4.3 MPa from 200 mbarg to 43 barg	90 kPa 900 mbarg
204/MPH + pre-reducer (R14)	400 kPa 4 barg	from 250 kPa to 4.3 MPa from 2.5 barg to 43 barg	280 kPa 2.8 barg
301/MP + pre-reducer (AR100)	16 kPa 160 mbarg	from 0.5 kPa to 10 kPa from 5 mbarg to 100 mbarg	16 kPa 160 mbarg
301/MP/TR + pre-reducer (AR100)	26 kPa 260 mbarg	from 10 kPa to 200 kPa from 100 mbarg to 2 barg	19 kPa 190 mbarg
302/MP/TR + pre-reducer (AR100)	47 kPa 470 mbarg	from 80 kPa to 950 kPa from 800 mbarg to 9.5 barg	36 kPa 360 mbarg
304/MP + pre-reducer (AR100)	120 kPa 1.2 barg	from 700 kPa to 4.3 MPa from 7 barg to 43 barg	90 kPa 900 mbarg
304/MPH + pre-reducer (AR100)	400 kPa 4 barg	from 700 kPa to 4.3 MPa from 7 barg to 43 barg	280 kPa 2.8 barg
204/MP/FO + pre-reducer (R14)	120 kPa 1.2 barg	from 100 kPa to 3.3 MPa from 1 barg to 33 barg	90 kPa 900 mbarg
204/MPH/FO + pre-reducer (R14)	400 kPa 4 barg	from 100 kPa to 3.3 MPa from 1 barg to 33 barg	280 kPa 2.8 barg
205/MP/FO + pre-reducer (R14)	120 kPa 1.2 barg	From 2 MPa to 6 MPa from 20 barg to 60 barg	90 kPa 900 mbarg
205/MPH/FO + pre-reducer (R14)	400 kPa 4 barg	from 2 Mpa to 6 MPa from 20 barg to 60 barg	280 kPa 2.8 barg

Table 2 Magnetic pilots models and features – International units of measurement

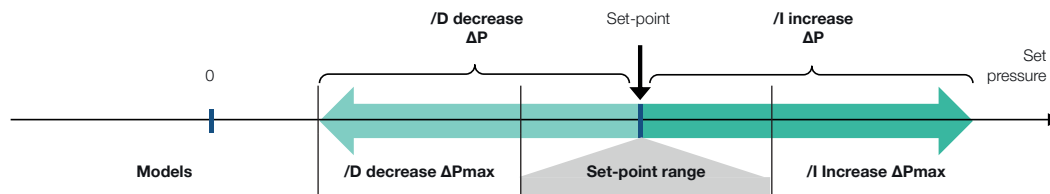

Models	/D decrease ΔP_{max}	Set-point range	/I Increase ΔP_{max}
201/MP + pre-reducer (R31)	2.32 psig	from 2.8" w.c. to 8.4 psig	1.74 psig
204/MP + pre-reducer (R14)	17.4 psig	from 2.9 psig to 623.7 psig	13.1 psig
204/MPH + pre-reducer (R14)	58.0 psig	from 36.3"psig to 623.7 psig	40 psig
301/MP + pre-reducer (AR100)	2.32 psig	from 2.0" w.c. to 1.45 psig	2.32 psig
301/MP/TR + pre-reducer (AR100)	3.77 psig	from 1.45 psig to 29.0 psig	2.76 psig
302/MP/TR + pre-reducer (AR100)	6.82 psig	from 11.6 psig to 137.8 psig	5.22 psig
304/MP + pre-reducer (AR100)	17.4 psig	from 101.5 psig to 623.7 psig	13.1 psig
304/MPH + pre-reducer (AR100)	58.0 psig	from 101.5 psig to 623.7 psig	40 psig
204/MP/FO + pre-reducer (R14)	17.4 psig	from 14.5 psig to 478.6 psig	13.1 psig
204/MPH/FO + pre-reducer (R14)	58.0 psig	from 14.5 psig to 478.6 psig	40 psig
205/MP/FO + pre-reducer (R14)	17.4 psig	from 290.1 psig to 870.2 psig	13.1 psig
205/MPH/FO + pre-reducer (R14)	58.0 psig	from 290.1 psig to 870.2 psig	40 psig

Table 3 Magnetic pilots models and features – Imperial units of measurement

B Flow control

Flow regulation plays an important role in stations: it **ensures compliance with contractual obligations** on gas allocation and with project technical specifications (e.g., metering accuracy and noise level), while ensuring an **adequate system safety level**. Limiting the flow rate can result in better regulator and meter accuracy, avoiding situation when equipment performance may be compromised.

The main flow rate regulation applications are:

- 1. Maximum flow rate management.** The pressure is reduced to keep the flow rate within the defined maximum limit value. This operation has the highest priority.
- 2. Minimum flow rate management.** The pressure is increased to keep the flow rate above the defined minimum limit value. Should the pressure reach the maximum value, the regulator closes shutting down the gas supply. It communicates this intervention by means of a digital signal.



Adherence to contractual and technical requirements



Enhanced system safety



Improved equipment accuracy



Automatic flow adjustment for optimal operation

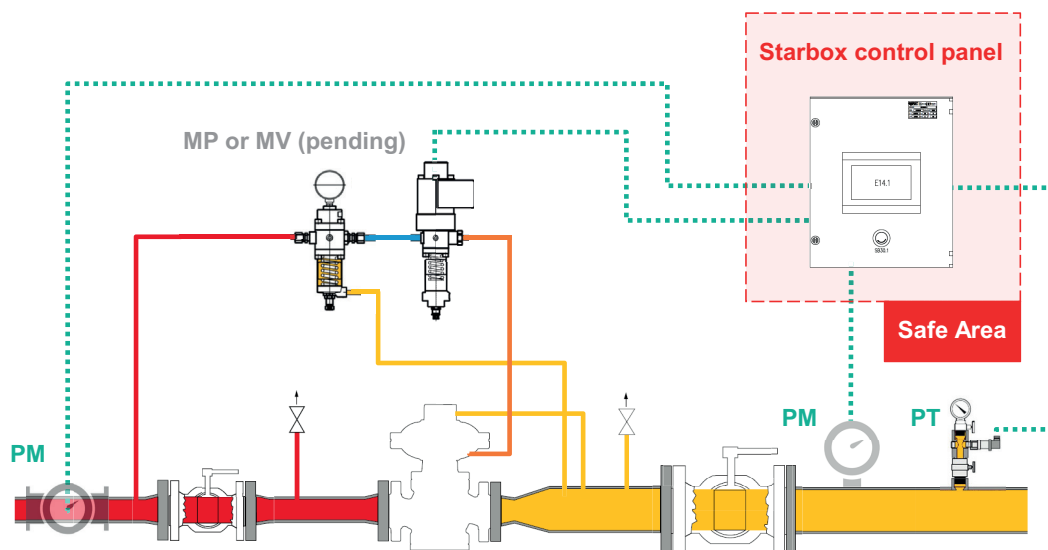

PM: Primary Meter (installed downstream or upstream)

MP or MV: 200/MP series or 300/MP series magnetic pilots or Controller 500/MV (pending)

PT: Pressure Transmitter

Figure 10 "Flow control" application

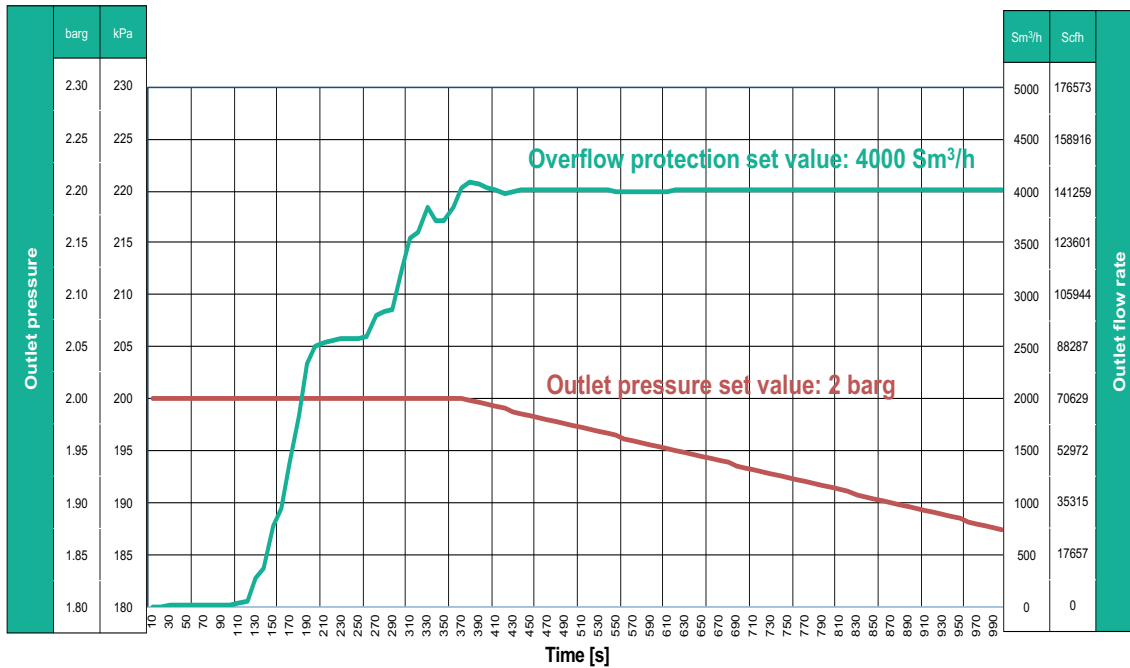

Figure 11 "Remote monitoring" application poster

What you need?

- Starbox control panel
- Primary meter or Indirect Flow Measurement (IFM)
- Downstream pressure transmitter
- 200/MP series or 300/MP series magnetic pilots or Controller 500/MV (pending)
- Q-KIT (optional)

Multiple line flow splitting

This functionality ensures that the flow rate of each individual line is regulated to its predefined set point, which may be specified as an absolute value or as a proportion of the total station flow. Flow distribution can be either uniform across multiple lines or managed according to a predefined control logic. For instance, when a line reaches its configured maximum flow rate, it continues operating at that threshold, and additional demand is redirected to subsequent lines as they are sequentially activated.



Efficient load distribution



Dynamic flow management

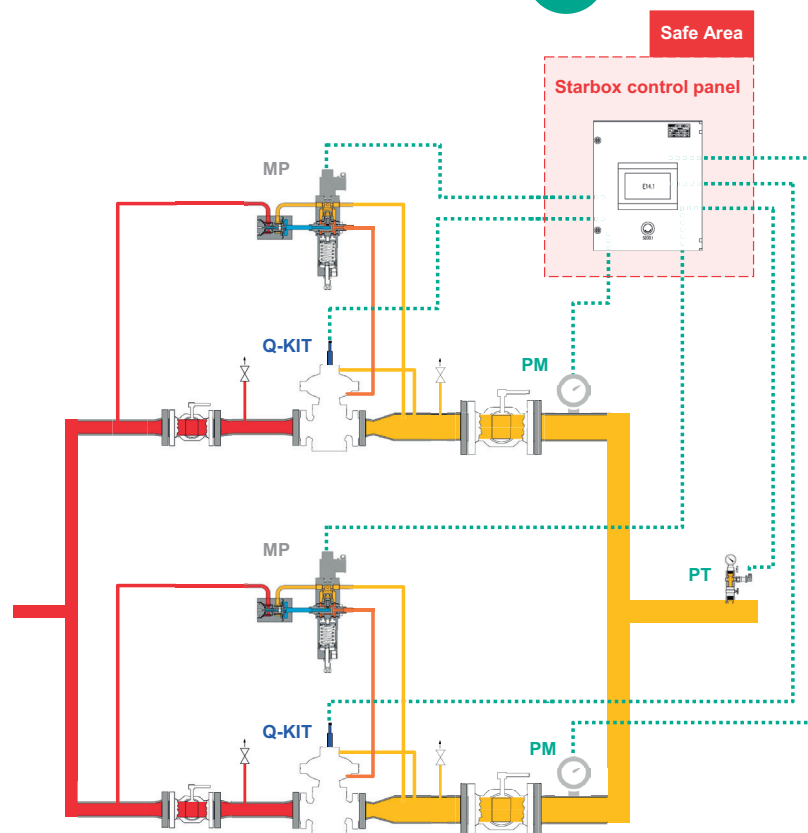

PM: Primary Meter (installed downstream or upstream)
MP: 200/MP series or 300/MP series magnetic pilots
PT: Pressure Transmitter

Figure 12 “Multiple line flow splitting” application poster

What you need?

- Starbox control panel
- 200/MP series or 300/MP series magnetic pilots
- Q-KIT
- Primary meter or other flow measurement
- Downstream pressure transmitter

Remote Monitoring

The FIO 3.0 remote control and monitoring system:

- **Collects** and **manages** data through communication systems (e.g., GPRS, 3G, 4G, ADSL, fiber optics, wireless networks, radio modem) and cloud platforms.
- Sends **real-time alert** signals to the right people, such as field operators, technicians and managers.

The FIO 3.0 solution enables monitoring and adjustment almost in real time main station's parameters remotely, **without the involvement of an on-site operator**. The frequency of an operator is greatly reduced, leading to a considerable **operational costs** saving and **risk reduction**.

Besides gas pressure and temperature, the FIO 3.0 system is able to monitor the following:



Filters clogging



Monitor takeover



Safety valves tripping
(slam shut, relief valve, etc.)



Facility access



Video surveillance



Vibration and earthquake
detector



Gas detector



Flood detector



Smoke and flame detector



Weather station (atmospheric
pressure, ambient temperature,
humidity)



Remote Monitoring for Gas Pressure Reduction Stations: Overview

Gas pressure reduction stations (GPRS), also known as pressure regulating stations, are critical infrastructure elements that ensure safe and efficient distribution of natural gas by reducing its pressure from transmission to distribution levels.

Traditionally, these stations required manual oversight and on-site intervention. However, **with advancements in IoT, SCADA systems, and sensor technologies, remote monitoring offers a modern, efficient alternative.**

Remote monitoring involves real-time data acquisition and control over key parameters (e.g., pressure, temperature, valve status) using communication networks, enabling operators to **supervise and manage multiple stations from a central location.**

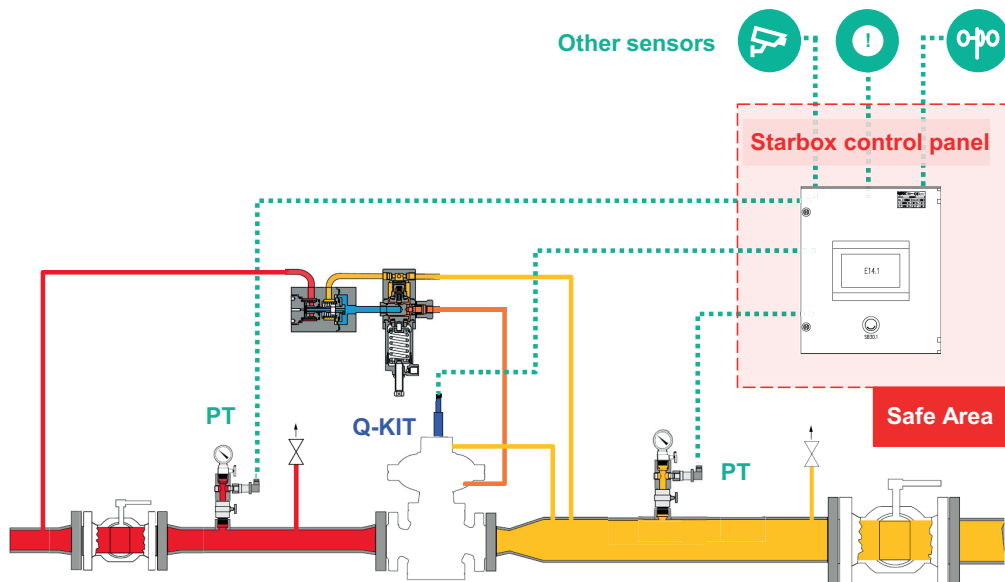

PT: pressure transmitter

Figure 13 "Remote monitoring" application poster

What you need?

- Starbox control panel
- Q-KIT
- Downstream and upstream pressure transmitter and additional sensors

D Remote disconnection

The FIO 3.0 offers a reliable and efficient solution for remote disconnection, allowing operators to **safely isolate the station from the natural gas distribution network without intervention**. On demand the system reduces the downstream pressure to the minimum value allowing the gas station to close and the regulators to be in lockup position. This feature is particularly interesting for multi-feeder system allowing to move the load from one station to another. On single feeder network the station will remain in close position until the downstream pressure will reduce to the set value by the network consumption. This not only enhances operational flexibility but **also contributes improving overall system resilience**.



Fast & precise



Safety risk minimizer



Flexibility



System resilience

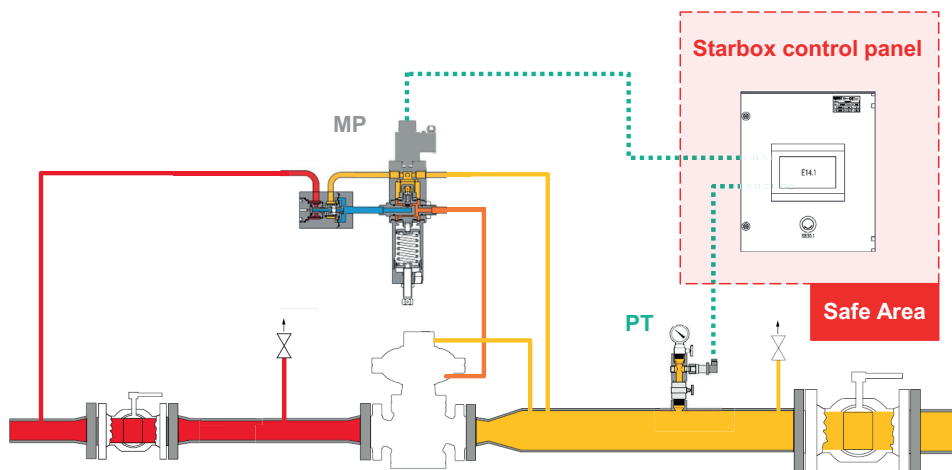

PT: pressure transmitter

MP: 200/MP series or 300/MP series magnetic pilots

Figure 14 “Remote disconnection” application poster

What you need?

- Starbox control panel
- 200/MP series or 300/MP series magnetic pilots
- Downstream pressure transmitters









E Indirect Flow Measurement

Understanding the amount of gas flowing through a station ensures accurate load calculations and a balanced supply in your gas system. In a **pressure reduction metering station (PRMS)**, this is typically achieved using a primary meter (such as a turbine, rotary, or ultrasonic meter) or a calibrated orifice plate connected to a flow computer.

Primary meters and calibrated orifice plates require space, flow conditioners, as well as specific upstream and downstream pipe sections. These requirements significantly impact the station layout and increase investment costs. Unless fiscal measurement is required, these impacts are not always justified.

The FIO 3.0 provides an **alternative solution: Indirect gas Flow Measurement (IFM)**.

-  Reduced installation costs
-  Low maintenance
-  Optimized layout
-  Real-time monitoring
-  Seamless retrofitting
-  Flexible application

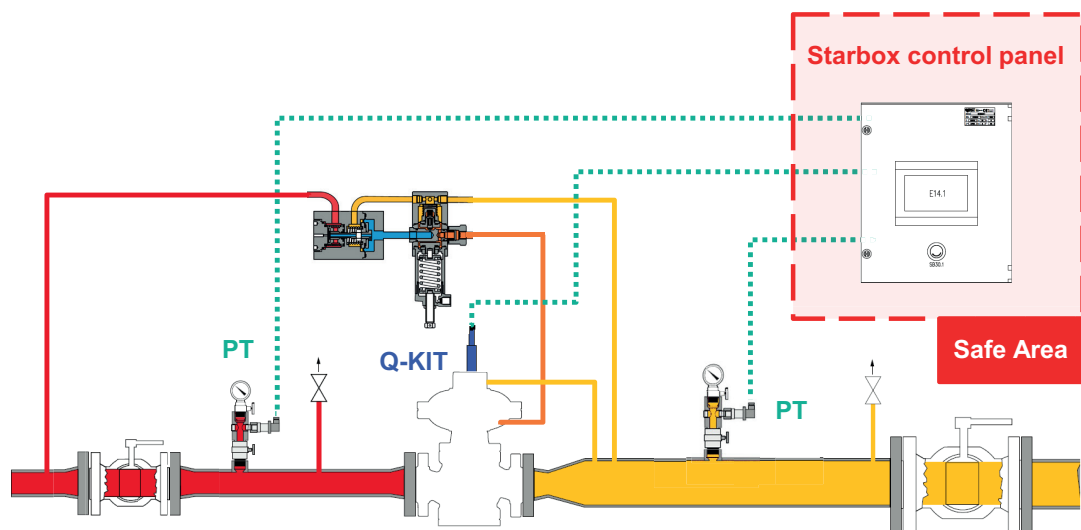

PT: pressure transmitter

Figure 15 "Indirect Flow Measurement" application poster

This type of measurement does not require the installation of measuring elements on the line and the upgrading of the power supply infrastructure, and it also **can be easily implemented on existing pressure regulation stations**.

Although not suitable for custody transfer measurement, **IFM** can be used in a **variety of applications** such as gas supply balancing or flow rate limitation.

The principle of operation of IFM is based on a relationship between the plug displacement, the pressure values upstream and downstream the regulator.

The flow calculation is carried out at predetermined intervals of time, with a maximum frequency of 1 time every 30 seconds. The IFM accuracy depends on regulator opening (see Fig.10).

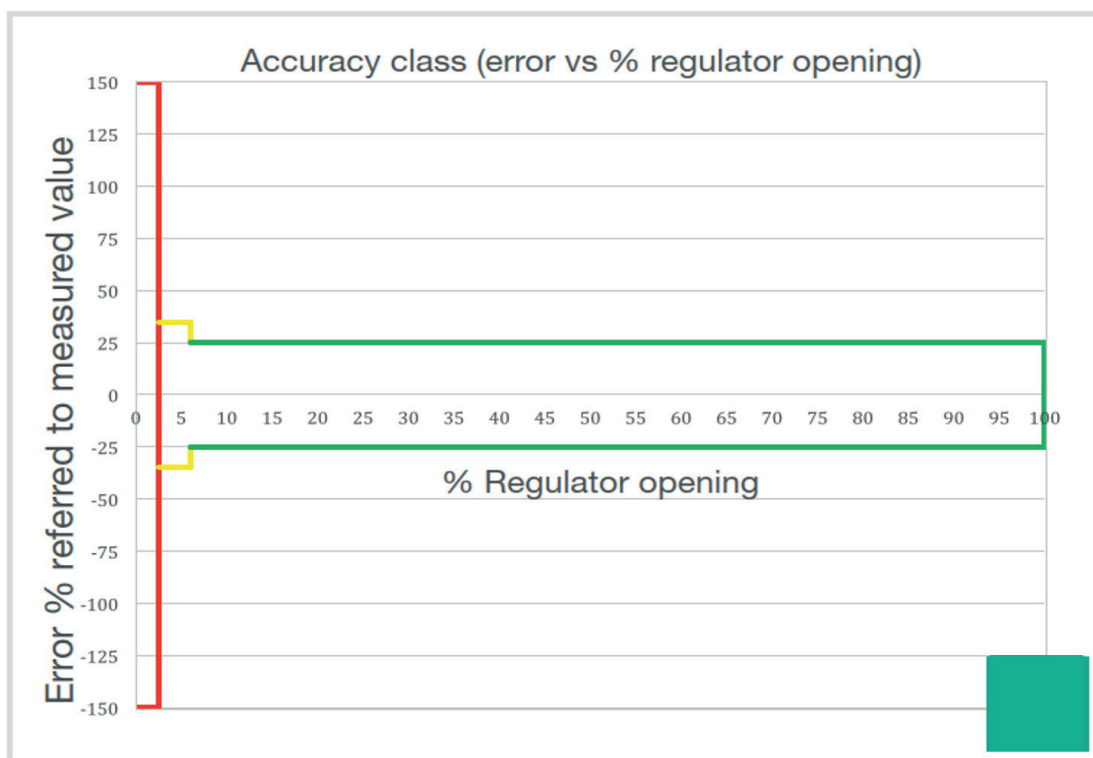

Figure 16 The graph shows the indicative flow rate error (%) with the regulator opening (%). The IFM accuracy stays within the limits defined by the red, yellow and green lines.

What you need?

- Starbox control panel
- Q-KIT
- Downstream and upstream pressure transmitter and additional sensors

FIONet™

Starbox LX2

Starbox LX2 is an innovative smart Linux based RTU, specifically designed for remote gas station control in harsh environmental conditions.



Starbox LX2 embodies the typical characteristics of a data logger with advanced multimedia features. In fact, it is a system where process control, multimedia capabilities, remote management and the internet are available and usable with identical operating standards and can be activated in a simple and intuitive way.

Remote multimedia and multi-access communication with operational centres

Remote connectivity can be supported by means of different technologies, such as GPRS, 3G, 4G, ADSL, Wireless Network and Radio Modem.

It can be easily connected to station PLC, local instrumentation and supervisors, as well as SCADA operational centres by means of a wide range of communication protocols.

Local connection possible through ETHERNET, RS232, RS485 and USB.

Embedded PLC

The integrated programmable controller allows the development of local control logics, for maximum flexibility and versatility of use.

Integrated multifunctional web server

It allows connection to the device through use of WEB browser for consultation of station live data and device configuration.



City gates



District stations

Features	Values
Analogue inputs (AI)	8 inputs, 16-bit resolution, configurable: 4-20 mA / 0-10 Vdc (with 2500 V galvanic isolation on request)
Digital inputs (DI)	16 inputs, 10-30 Vdc, configurable as status inputs or meter inputs, opto-isolated with 2500 V galvanic isolation
Analogue outputs (AO)	1 output, 16-bit resolution, 0-10 Vdc
Digital outputs (DO)	8 outputs, 10-30 Vdc, opto-isolated with 2500 V galvanic isolation
Expandability	Up to 320 DI, 128 DO, 64 AI, 32 AO via modular I/O systems
Communication vector	External Modem/Router, typical channels GSM/GPRS-LAN 4G/5G/wired (other communication technologies available upon request)
Registration No.	Modbus RTU/TCP Master/Slave, IEC 62056-2, IEC 60870-5-101, IEC 60870-5-104, Siemens S7
Local communication	1 Ethernet port, 1 Ethernet port (optional), 2 serial ports RS485/422, 1 configurable serial port RS232, 1 configurable serial port RS232/RS485, 1 USB port
Case	IP 20

Features	Values
HMI	LCD display touch screen (optional)
Power supply	10 – 30 Vdc
Typical absorption	1 - 4 W
Expandable memory	USB, SD CARD (on request)
Environmental conditions	from -20°C to + 80°C
Dimensions	165x150x55 (mm)

Table 1 Features

Features and Approvals

Features	Values
Automation	PLC EMBEDDED compliant with standard IEC 61131-3
User messages	SMS / email
Alarms	Warning and management of alarms and events generated by exceeding thresholds and/or reaching physical/logical states
Datalogging	Data acquisition and logging with the following features: Basic acquisition time: 1" Basic storage time: 5' - 1h Maximum number of variables that can be acquired: 10,000 Maximum number of samples stored: 6,000,000 Sample processing: instantaneous, min, max, average
Discovery Mode	Data acquisition with a frequency of 50 Hz for the detection of water hammer phenomena, with a time depth of 5 min
OPC connectivity	Supported via OPC SERVER
Configuration	Through the integrated WEB server or through the Rainbow Configurator SW
User Application	Using languages in a LINUX environment
Operating system	LINUX embedded

Table 2 Features and values

Starbox LX2 competitive advantages



Multimedia and multi-access connectivity



Integrated functions for pressure regulation and energy efficiency



Modular and scalable I/O configuration



Low energy consumption



Extended programmability through Embedded PLC



VPN-based encrypted communication

 **FIO**Net™

Pilot series 200/MP

The **pilot series 200/MP** is an electro-mechanical device which enables remote setpoint modifications of pilot operated gas pressure regulators. Furthermore, the pilot optimizes the accuracy and lock-up performances thanks to real-time pulse width modulation control. It is suitable with Reval 182, Reflux 819 and ASX 176 regulators and, upon request, it can be used with any brand with the same working principle.



Gas compression / booster stations



City gates



Gas reverse-flow



Gas storage



Power generation



District stations

Features	Values		
Design pressure* (PS ¹ / DP ²)	up to 10.2 MPa up to 102 bar		
Ambient temperature* (TS ¹)	from -20 °C to +60 °C from -4 °F to +140 °F		
Inlet gas temperature*	from -20 °C to +60 °C from -4 °F to +140 °F		
Inlet pressure (MAOP / p _{umax} ¹)	from 0.02 to 10 MPa from 0.2 to 100 bar (Depending on the model)		
Range of downstream pressure (Wd ¹)	from 0.7 kPa to 6.0 MPa from 7 mbarg to 60 barg (Depending on the model)		
Maximum power consumption	30 W		
PWM input signal	0 – 10 V or 4-20 mA upon request		
ATEX Certification	CE  II 2/- G Ex h IIC T5 Gb		
IECEX Certification	(in progress)		
Models	201/MP + Prereducer (R31)	204/MP + Prereducer (R14)	204/MPH + Prereducer (R14)
Minimum set-point P _{ds min}	0.7 kPa 7 mbarg	20 kPa 200 mbarg	0.25 MPa 2.5 bar
Maximum set-point P _{ds max}	58 kPa 580 mbarg	4.3 MPa 43 bar	4.3 MPa 43 bar
Maximum setpoint variation ΔP With failover to maximum setpoint (decrease version)	16 kPa 160 mbarg	0.12 MPa 1.2 bar	0.4 MPa 4 bar
Maximum setpoint variation ΔP With failover to minimum setpoint (increase version)	12 kPa 120 mbarg	90 kPa 900 mbarg	0.28 MPa 2.8 bar
Accuracy class (AC ¹)	up to 1 (depending on working conditions)		
Lock-up pressure class (SG ¹)	up to 1 (depending on working conditions)		
Pneumatic connections*	1/4" RP - UNI EN ISO 226 1/4" NPT - ANSI B 1.20.1		

(¹) according to EN334 standard

(²) according to ISO 23555-1 standard

(*) NOTE: Different functional features and/or extended temperature ranges may be available on request. Stated inlet gas temperature range is the maximum for which the equipment's full performance, including accuracy is guaranteed. Product may have a different pressure or temperature ranges according to the version and/or installed accessories.

Table 1 Features

Materials and Approvals

Part	Material
Body	Aluminium
Cover	Aluminium
Plug	NBR
Seat	Stainless Steel
Diaphragms	Nitrile rubber
Sealing rings	NBR

NOTE: The materials indicated above refer to the standard models. Different materials can be provided according to specific needs.

Table 2 Materials

The **Pilot 200/MP** is designed according to the EN334 where applicable. The device meets the requirements of Directive 2014/34/EU (ATEX). Directive 2014/68/EU (PED) is not applicable due to Article 4 paragraph 3 of the Directive.



EN 334



ATEX



IECEX

Pilot 200/MP competitive advantages



Compact and simple design



Multi brand compatibility*
*To be verified on a case-by-case basis



Remote set-point variation



Easy maintenance



High accuracy



Pulse Width Modulation (PWM) control



Failover to max or min
mechanical set-point



No vent

 **FIO**Net™

Pilot series 200/MP/FO

The **pilot series 200/MP/FO** is an electro-mechanical device which enables remote setpoint modifications of pilot operated gas pressure regulators. Furthermore, the pilot optimizes the accuracy and lock-up performances thanks to real-time pulse width modulation control. It is suitable with Reflux 819/FO and ASX 176/FO regulators and, upon request, it can be used with any brand with the same working principle.



Gas compression / booster stations



City gates



Gas reverse-flow



Gas storage



Power generation



District stations

Features	Values			
Design pressure* (PS ¹ / DP ²)	up to 10.2 MPa up to 102 barg			
Ambient temperature* (TS ¹)	from -20 °C to +60 °C from -4 °F to +140 °F			
Inlet gas temperature*	from -20 °C to +60 °C from -4 °F to +140 °F			
Inlet pressure (MAOP / p _{umax} ¹)	from 0.02 to 10 MPa from 0.2 to 100 barg (Depending on the model)			
Range of downstream pressure (Wd ¹)	from 0.7 kPa to 6.0 MPa from 7 mbarg to 60 barg (Depending on the model)			
Maximum power consumption	30 W			
PWM input signal	0 – 10 V or 4-20 mA upon request			
ATEX Certification	CE Ex II 2/- G Ex h IIC T5 Gb			
IECEX Certification	(in progress)			
Models	204/MP/FO + prereducer (R31)	204/MPH/FO + prereducer (R31)	205/MP/FO + prereducer (R31)	205/MPH/FO + prereducer (R31)
Minimum set-point P _{ds min}	0.1 MPa 1 barg	0.1 MPa 1 barg	2 MPa 20 barg	2 MPa 20 barg
Maximum set-point P _{ds max}	3.3 MPa 33 barg	3.3 MPa 33 barg	6 MPa 60 barg	6 MPa 60 barg
Maximum setpoint variation ΔP With failover to maximum setpoint (decrease version)	0.12 MPa 1.2 barg	0.4 MPa 4 barg	0.12 MPa 1.2 barg	0.4 MPa 4 barg
Maximum setpoint variation ΔP With failover to minimum setpoint (increase version)	90 kPa 900 mbarg	0.28 MPa 2.8 barg	90 kPa 900 mbarg	0.28 MPa 2.8 barg
Accuracy class (AC ¹)	up to 1 (depending on working conditions)			
Lock-up pressure class (SG ¹)	up to 1 (depending on working conditions)			
Pneumatic connections*	1/4" RP - UNI EN ISO 226 1/4" NPT - ANSI B 1.20.1			

(¹) according to EN334 standard

(²) according to ISO 23555-1 standard

(*) NOTE: Different functional features and/or extended temperature ranges may be available on request. Stated inlet gas temperature range is the maximum for which the equipment's full performance, including accuracy is guaranteed. Product may have a different pressure or temperature ranges according to the version and/or installed accessories.

Table 1 Features

Materials and Approvals

Part	Material
Body	Aluminium
Cover	Aluminium
Plug	NBR
Seat	Stainless Steel
Diaphragms	Nitrile rubber
Sealing rings	NBR

NOTE: The materials indicated above refer to the standard models. Different materials can be provided according to specific needs.

Table 2 Materials

The **Pilot 200/MP/FO** is designed according to the EN334 where applicable. The device meets the requirements of Directive 2014/34/EU (ATEX). Directive 2014/68/EU (PED) is not applicable due to Article 4 paragraph 3 of the Directive.



EN 334



ATEX



IECEx

Pilot 200/MP/FO competitive advantages



Compact and simple design



Multi brand compatibility*
*To be verified on a case-by-case basis



Remote set-point variation



Easy maintenance



High accuracy



Pulse Width Modulation (PWM) control



Failover to max or min
mechanical set-point



No vent

FIONet™

Pilot series 300/MP



The **pilot series 300/MP** is an electro-mechanical device which enables remote setpoint modifications of pilot operated gas pressure regulators. Furthermore, the pilot optimizes the accuracy and lock-up performances thanks to real-time pulse width modulation control. It is suitable with Aperval and Aperflux 851 regulators and, upon request, it can be used with any brand with the same working principle.



Gas compression / booster stations



City gates



Gas reverse-flow



Gas storage



Power generation



District stations

Features	Values					
Design pressure* (PS ¹ / DP ²)	up to 10.2 MPa up to 102 bar					
Ambient temperature* (TS ¹)	from -20 °C to +60 °C from -4 °F to +140 °F					
Inlet gas temperature*	from -20 °C to +60 °C from -4 °F to +140 °F					
Inlet pressure (MAOP / p _{umax} ¹)	from 0.05 to 10 MPa from 0.5 to 100 bar (Depending on the model)					
Range of downstream pressure (Wd ¹)	from 0.5 kPa to 4.3 MPa from 5 mbarg to 43 bar (Depending on the model)					
Maximum power consumption	30 W					
PWM input signal	0 – 10 V or 4-20 mA upon request					
ATEX Certification	CE  II 2/- G Ex h IIC T5 Gb					
IECEX Certification	(in progress)					
Models	301/MP + Prereducer (AR100)	301/MP/TR + Prereducer (AR100)	302/MP + Prereducer (AR100)	304/MP + Prereducer (AR100)	304/MPH + Prereducer (AR100)	
Minimum set-point P _{ds min}	0.5 kPa 5 mbarg	10 kPa 100 mbarg	80 kPa 0.8 barg	0.7 MPa 7 barg	0.7 MPa 7 barg	
Maximum set-point P _{ds max}	10 kPa 100 mbarg	0.2 MPa 2 barg	0.95 MPa 9.5 barg	4.3 MPa 43 barg	4.3 MPa 43 barg	
Maximum setpoint variation ΔP With failover to maximum setpoint (decrease version)	Up to 16 kPa Up to 160 mbarg	Up to 26 kPa Up to 260 mbarg	Up to 47 kPa Up to 470 mbarg	Up to 0.12 MPa Up to 1.2 barg	Up to 0.4 MPa Up to 4 barg	
Maximum setpoint variation ΔP With failover to minimum setpoint (increase version)	Up to 16 kPa Up to 160 mbarg	Up to 19 kPa Up to 190 mbarg	Up to 36 kPa Up to 360 mbarg	Up to 90 kPa Up to 900 mbarg	Up to 0.28 MPa Up to 2.8 barg	
Accuracy class (AC ¹)	up to 1 (depending on working conditions)					
Lock-up pressure class (SG ¹)	up to 1 (depending on working conditions)					
Pneumatic connections*	1/4" RP - UNI EN ISO 226 1/4" NPT - ANSI B 1.20.1					

(¹) according to EN334 standard

(²) according to ISO 23555-1 standard

(*) NOTE: Different functional features and/or extended temperature ranges may be available on request. Stated inlet gas temperature range is the maximum for which the equipment's full performance, including accuracy is guaranteed. Product may have a different pressure or temperature ranges according to the version and/or installed accessories.

Table 1 Features

Materials and Approvals

Part	Material
Body	Aluminium
Cover	Aluminium
Plug	NBR
Seat	Stainless Steel
Diaphragms	Nitrile Rubber
Sealing rings	NBR

NOTE: The materials indicated above refer to the standard models. Different materials can be provided according to specific needs.

Table 2 Materials

The **Pilot series 300/MP** is designed according to the EN334 where applicable. The device meets the requirements of Directive 2014/34/EU (ATEX). Directive 2014/68/EU (PED) is not applicable due to Article 4 paragraph 3 of the Directive.



EN 334



ATEX



IECEX

Pilot series 300/MP competitive advantages



Compact and simple design



Multi brand compatibility*
*To be verified on a case-by-case basis



Remote set-point variation



Easy maintenance



High accuracy



Pulse Width Modulation (PWM) control



Failover to max or min
mechanical set-point



No vent

 **FIO**Net™

PENDIENTE

Controller 500/MV



El **Controller 500/MV** es una válvula electromecánica que transforma un regulador de presión tradicional en una válvula de diafragma de control. El control PWM continuo optimiza la precisión y las prestaciones de bloqueo. Es **compatible con cualquier regulador de presión de piloto Pietro Fiorentini** y, bajo pedido, puede utilizarse con **cualquier marca con el mismo principio de funcionamiento**. En función de la versión seleccionada, el Controller 500/MV puede ser normalmente cerrado (NC) o normalmente abierto (NA). Este dispositivo se utiliza principalmente en sistemas de transmisión de alta presión y en redes de distribución de gas de media presión.



Licuefacción de gas



Puntos de entrega



Generación de energía



Compresión del gas /
estaciones de refuerzo



Industria pesada



GNL marino



Almacenamiento de gas



Regasificación



Flujo inverso del gas

Características	Valores
Presión de diseño* (PS ¹ / DP ²)	hasta 10,2 MPa hasta 102 bar
Temperatura ambiente* (TS ¹)	de -20 °C a +60 °C de -4 °F a +140 °F
Temperatura del gas de entrada*	de -20 °C a +60 °C de -4 °F a +140 °F
Presión de entrada (MAOP / p _{umax} ¹)	de 0,02 a 10 MPa de 0,2 a 100 bar
Rango de presión aguas abajo (Wd ¹)	de 0,6 MPa a 7,4 MPa de 6 barg a 74 barg
Fuente de alimentación	24 VDC
Señal de entrada PWM	0 - 10 V o 4-20 mA bajo pedido
Certificación ATEX	CE  II 2/- G Ex h IIC T5 Gb
Certificación IECEX	(en curso)
Punto de ajuste mínimo P _{ds min} ¹	0,6 MPa 6 barg
Punto de ajuste máximo P _{ds max} ¹	hasta 7,4 MPa hasta 74 barg
Variación máxima del punto de ajuste ΔP _{s max} ¹	6,8 MPa 68 barg
Clase de precisión (AC ¹)	hasta 1 (en función de las condiciones de trabajo)
Clase de presión de bloqueo (SG ¹)	hasta 1 (en función de las condiciones de trabajo)
Conexiones neumáticas*	1/4" RP - UNI EN ISO 226 1/4" NPT - ANSI B 1.20.1

(¹) de acuerdo con la norma EN334

(²) de acuerdo con la norma ISO 23555-1

(*) NOTA: Otras características funcionales o rangos de temperatura ampliados pueden estar disponibles bajo pedido. El rango de temperatura de gas de entrada indicado es el máximo para el que se garantizan todas las prestaciones del equipo, incluida la precisión. El producto puede tener rangos de temperatura o presiones distintas de acuerdo con la versión o los accesorios instalados.

Tabla 1 Características

Materiales y aprobaciones

Pieza	Material
Cuerpo	Aluminio
Tapa	Aluminio
Tapón	NBR
Asiento	Acero inoxidable
Diafragmas	Goma de nitrilo
Anillos de estanqueidad	NBR

NOTA: los materiales indicados anteriormente se refieren a los modelos estándares. Se pueden proporcionar diferentes materiales según las necesidades específicas.

Tabla 2 Materiales

El Controller 500/MV está diseñado de acuerdo con la norma EN334, si procede.

En caso de fallo neumático (como un fallo del diafragma), el dispositivo sigue funcionando.

En caso de fallo de la alimentación eléctrica, el motor magnético deja de funcionar y el aparato reacciona cerrando el circuito neumático (NC) o abriendo el circuito neumático (NA), según la versión instalada.

El dispositivo cumple los requisitos de la directiva 2014/34/UE (ATEX).

La Directiva 2014/68/UE (PED) no es aplicable debido al artículo 4, apartado 3, de la Directiva.



EN 334



ATEX



IECEx

Ventajas competitivas del **Controller 500/MV**



Diseño compacto y sencillo



Mantenimiento sencillo



Variación remota del punto de ajuste



Control por modulación de anchura de impulsos (PWM)



Alta precisión



Control de seguridad por subpresión y/o sobrepresión (opcional)



Conmutación de apertura o cierre (según la versión seleccionada)



Sin ventilación



Compatibilidad multimarca*

*Se verificará caso por caso.

FIONet™

Q-KIT

Pietro Fiorentini's plug-and-seat regulators can be equipped with a sensor to measure the regulator's opening (available for Reflux 819 - Reval 182 - Dixi - Aperflux 851 - Terval/R - ASX 176 - Norval). This sensor requires low power as it is based on electrical resistance measurement. An internal element changes resistance depending on the position of the diaphragm, and an electrical circuit measures this resistance. During the setup operation, the relationship between resistance/opening (position) is determined.



Reflux 819



Reval 182



Dixi



Aperflux 851



Terval/R



ASX 176



Norval

Features	Values		
Q-KIT model	From DN 1" to DN 4" regulators	DN 6" and DN 10" regulators	DN 12" regulators
Maximum stroke	50 mm	75 mm	100 mm
Max applicable voltage	40 V	60 V	
Repeatability	< 0.01 mm		
Operating temperature	From -30°C to +100°C From -22°F to +212°F		
Shift speed	≤ 10 m/s		
Shift force	≤ 0.5 N		
Electrical connections	Shielded cable 3-pole 3x0.25-1 m		
Protection	IP60		
Certification	RoHS 2011/65/EU, EN 60079-11:2012 "I", S.I. 2012/3032, EN 50581:2012 and EN IEC 63000:2018		
Mechanics and anchorage	Flange		

Table 1 Features

Materials and Approvals

Part	Material
Body	Anodized aluminum
Drive shaft	Stainless steel

NOTE: the materials indicated above refer to the standard models. Different materials can be provided according to specific models.

Table 2 Materials

The Q-KIT is manufactured according with the community Directives and related National Legislation of conception 2011/65/EU (RoHS), EN 60079-11:2012 Standard (electrical apparatus for potentially explosive atmospheres – Intrinsic safety “i”) and S.I. 2012/3032 (electronical/electronic equipment UK regulations 2012).

The Q-KIT complies with the harmonized standards EN 50581:2012 and EN IEC 63000:2018.



RoHS
2011/65/EU



EN 60079
- 11:2012 “i”



S.I.
2012/3032



EN
50581:2012



EN IEC
63000:2018

Q-KIT competitive advantages



Cost-effective solution



Compact and simple design



Available for retrofitting



No maintenance needed



Weights and Dimensions

Starbox control panel

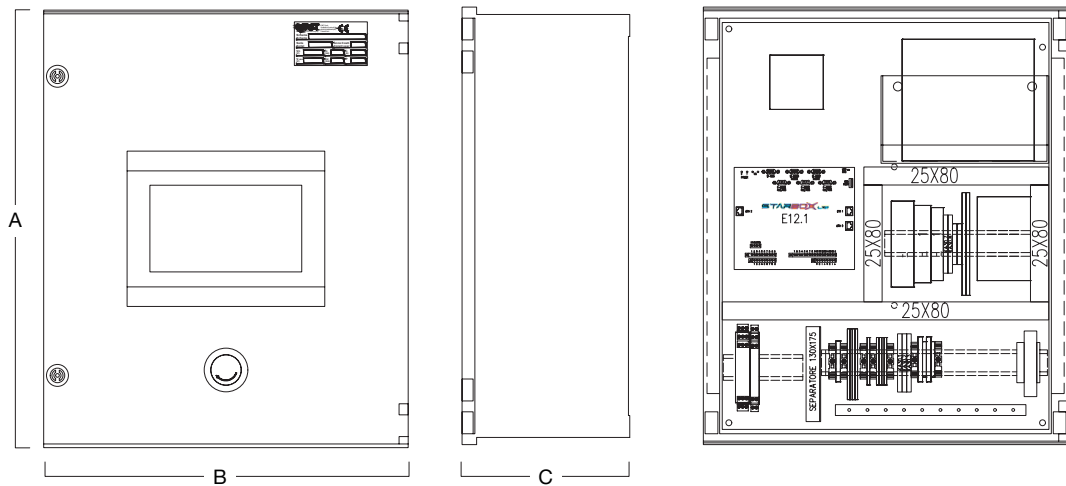

Figure 17 Starbox control panel dimensions

Dimensions and weight		
Dimensions	[mm]	inches
A	600	23.7
B	500	19.7
C	230	9.1
Weight	Kg	lbs
	15	33.1

Table 5 Weights and dimensions

PWM

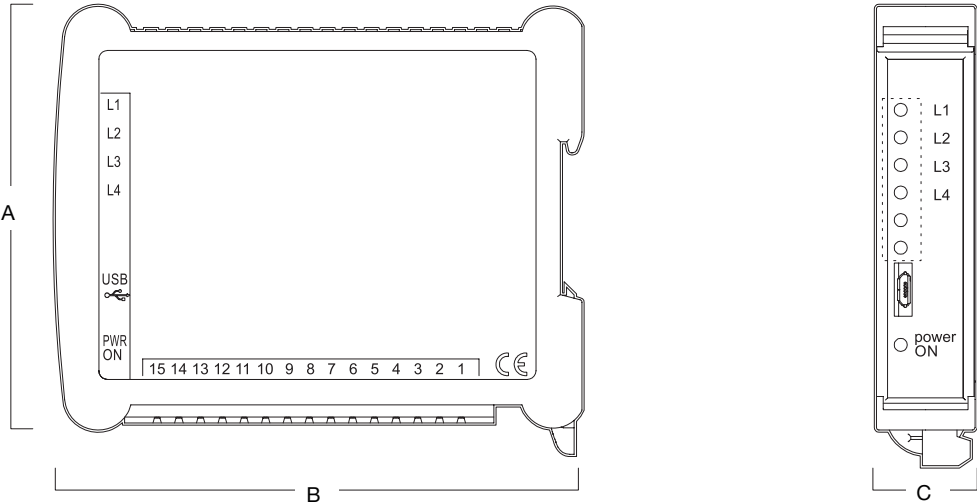

Figure 18 PWM dimensions

Dimensions and weight		
Dimensions	[mm]	inches
A	122	4.8
B	98	3.9
C	23	0.9
Weight	Kg	lbs
	0.15	0.33

Table 6 Weights and dimensions



Magnetic pilot Series 200/MP

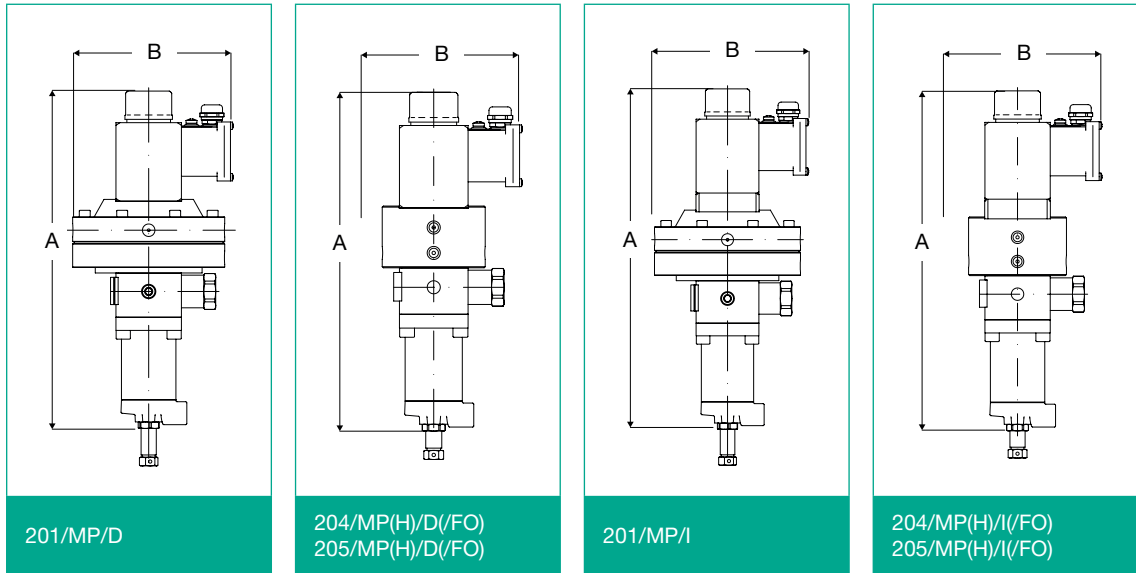

Figure 19 Magnetic pilot series 200/MP dimensions

Dimensions and weight													
Model	201/MP/D		204/MP/D/(FO) 205/MP/D/(FO)		204/MPH/D/(FO) 205/MPH/D/(FO)		201/MP/I		204/MP/I 205/MP/I		204/MPH/I/(FO) 205/MPH/I/(FO)		
	[mm]	inches	[mm]	inches	[mm]	inches	[mm]	inches	[mm]	inches	[mm]	inches	
A	310	12.2	296	11.7	322	12.7	326	12.8	312	12.3	338	13.3	
B	145	5.7	120	4.7	120	4.7	145	5.7	120	4.7	120	4.7	
Weight	Kg	lbs	Kg	lbs	Kg	lbs	Kg	lbs	Kg	lbs	Kg	lbs	
	5.6	12.3	4.5	9.9	4.5	9.9	5.6	12.3	4.5	9.9	4.5	9.9	

Table 7 Weights and dimensions

Magnetic pilot Series 300/MP

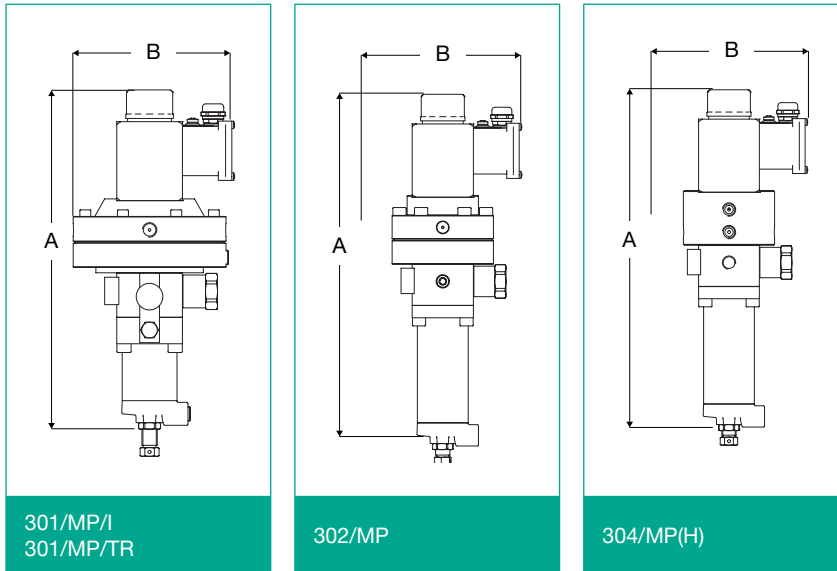

Figure 20 Magnetic pilot series 300 MP dimensions

Dimensions and weight						
Model	301/MP 301/MP/T		302/MP		304/MP 304/MPH	
	[mm]	inches	[mm]	inches	[mm]	inches
A	310	12.2	349	13.7	326	13.2
B	145	5.7	125	4.9	120	4.7
Weight	Kg	lbs	Kg	lbs	Kg	lbs
	5.6	12.3	4.8	10.6	4.5	9.9

Table 8 Weights and dimensions



Q-KIT

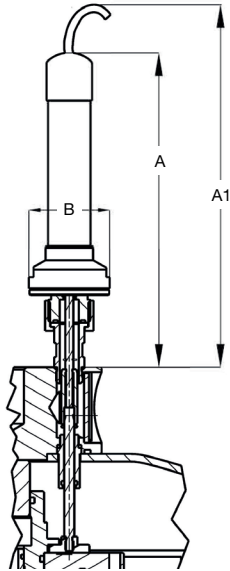

Figure 21 Q-KIT dimensions

Dimensions and weight			
Dimensions		mm	inches
A	From DN 1" to DN 4" regulators	156	6.1
	From DN 6" to DN 10" regulators	181	7.1
	DN 12" regulator	206	8.1
	Dixi regulator	174	6.9
A1	From DN 1" to DN 4" regulators	236	9.3
	From DN 6" to DN 10" regulators	261	10.3
	DN 12" regulator	286	11.3
B		40	1.6
Weight		Kg	lbs
From DN 2" to DN 6" regulators		0.13	0.29
DN 8" and DN 10" regulators		0.16	0.35
DN 12" regulator		2	4.41

Table 9 Weights and dimensions



**Pietro
Fiorentini**





Pietro Fiorentini

TB0162ENG



The data are not binding. We reserve the right
to make changes without prior notice.

FIO3-0_technicalbrochure_ENG_revB

www.fiorentini.com