

GEDRA

Gas quality analyzer



Revision A - Edition 02/2026

**USER, MAINTENANCE
AND WARNING MANUAL**

PAGE INTENTIONALLY LEFT BLANK

1 - INTRODUCTION

FOREWORD

All rights reserved. No part of this publication may be reproduced, distributed, translated into other languages or transmitted by any electronic or mechanical media, including photocopies, recording or any other storage and retrieval system, for any other purposes that are not exclusively the personal use of the buyer, without the express written permission of the Manufacturer.

The manufacturer is in no way responsible for the consequences of operations carried out in a manner not in accordance with the manual.

GENERAL REMARKS

All operating, maintenance instructions and recommendations described in this manual must be followed to in order to:

- obtain the best possible performance from the equipment;
- keep the equipment in efficient conditions.

Training the personnel in charge is essential in order to:

- use and service the equipment properly;
- correctly apply the safety alerts and procedures recommended.

NOTICE!

The images shown in this document indicate the type of product and may differ in detail.

PAGE INTENTIONALLY LEFT BLANK

1.1 - REVISION HISTORY

Revision index	Date	Description
A	02/2026	Publication
-	-	-
-	-	-

Tab. 1.1.

INDEX

1 - INTRODUCTION	3
1.1 - REVISION HISTORY	5
2 - GENERAL INFORMATION	11
2.1 - MANUFACTURER IDENTIFICATION	11
2.2 - IDENTIFICATION OF THE PRODUCT	11
2.3 - REGULATORY FRAMEWORK	11
2.4 - WARRANTY	12
2.5 - ADDRESSEES, SUPPLY AND STORAGE OF THE MANUAL	12
2.6 - LANGUAGE	12
2.7 - SYMBOLS USED IN THE MANUAL	13
2.8 - EQUIPMENT GLOSSARY	14
2.9 - UNIT OF MEASUREMENT	14
2.10 - QUALIFIED PROFESSIONAL FIGURES	15
2.11 - IDENTIFICATION PLATES APPLIED TO THE EQUIPMENT	16
2.11.1 - ATEX/IECEX PLATE	16
2.11.2 - METROLOGICAL PLATE	18
2.11.3 - FIELD DISPLAY IDENTIFICATION PLATE	19
3 - SAFETY	21
3.1 - GENERAL SAFETY WARNINGS	21
3.2 - ATEX AND IECEX DIRECTIVE SAFETY INSTRUCTIONS	22
3.2.1 - ELECTROSTATIC DISCHARGES	23
3.2.2 - SAFETY INSTRUCTIONS FOR INSTALLATION IN HAZARDOUS AREA	23
3.3 - PERSONAL PROTECTIVE EQUIPMENT	24
3.4 - OBLIGATIONS AND PROHIBITIONS	25
3.5 - RESIDUAL RISKS	26
3.5.1 - RISK OF ELECTROSTATIC DISCHARGE	26
3.5.2 - RISKS FOR POTENTIALLY EXPLOSIVE ATMOSPHERES	27
3.6 - SAFETY AND FRAUD PREVENTION	28
3.7 - SAFETY PICTOGRAMS	29
3.8 - NOISE LEVEL	29

4 - DESCRIPTION AND OPERATION 31

4.1 - GENERAL DESCRIPTION	31
4.2 - SYSTEM ARCHITECTURE	31
4.3 - ACQUISITION MODULE	34
4.3.1 - INSTALLING THE ACQUISITION MODULE	39
4.4 - FIELD DISPLAY	41
4.5 - METROLOGICAL AND INSTALLATION SEALS	42
4.6 - ELECTRICAL CHARACTERISTICS OF CABLES	43
4.7 - METROLOGICAL OPERATING RANGE	44
4.8 - DESIGNED USE	45
4.8.1 - INTENDED USE	45
4.8.2 - REASONABLY FORESEEABLE MISUSE	45
4.9 - TECHNICAL DATA	46

5 - USER INTERFACE 47

5.1 - GENERAL DESCRIPTION	47
5.2 - STARTUP PROCEDURE	50
5.3 - LOGIN PROCEDURE	54
5.4 - OPERATIONS PERMITTED BY THE “USER” PROFILE	56
5.4.1 - CHANGE THE PASSWORD	57
5.4.2 - VIEW THE ANALYSIS	58
5.4.3 - READING THE ANALYSIS HISTORY	59
5.4.4 - EVENT SEARCH	61
5.4.5 - SETTINGS.....	63
5.4.5.1 - SYSTEM.....	63
5.4.5.2 - ANALYSIS SETTINGS.....	64
5.4.5.3 - ALARMS.....	65
5.4.5.4 - SERIAL.....	66
5.4.5.5 - ETHERNET	67
5.4.6 - DETAILS.....	67
5.5 - OPERATIONS PERMITTED BY THE “MAINTENANCE TECHNICIAN” PROFILE.....	70
5.5.1 - SETTINGS.....	70
5.5.1.1 - SYSTEM.....	71
5.5.1.2 - ANALYSIS.....	79
5.5.1.3 - ALARMS.....	81
5.5.1.4 - SERIAL.....	84
5.5.1.5 - ETHERNET	86
5.5.2 - USERS.....	86
5.5.3 - PERIODIC VERIFICATION.....	88

5.6 - ADMINISTRATOR PROFILE	96
5.6.1 - ANALYSIS READING	96
5.6.2 - EVENT SEARCH	100
5.6.3 - SETTINGS.....	102
5.6.3.1 - FIRMWARE.....	102
5.6.4 - USERS.....	103
5.7 - PROPRIETARY PROFILE.....	105
5.7.1 - USERS.....	105

6 - TRANSPORT AND HANDLING 107

6.1 - SPECIFIC WARNINGS FOR TRANSPORT AND HANDLING	107
6.1.1 - PACKAGING AND FASTENERS USED FOR TRANSPORT	108
6.1.2 - MARKINGS AND WARNINGS	109
6.2 - PACKAGING CONTENT	109
6.3 - PHYSICAL CHARACTERISTICS OF THE COMPONENTS.....	110
6.3.1 - ACQUISITION MODULE GEDRA IN HAZARDOUS AREAS.....	110
6.3.2 - PNEUMATIC PANEL GEDRA.....	111
6.3.3 - FIELD DISPLAY GEDRA IN SAFE AREAS.....	112
6.4 - PHYSICAL CHARACTERISTICS OF THE FRAME GEDRA.....	113
6.4.1 - ASSEMBLED ASSEMBLY VIEW.....	113
6.5 - EQUIPMENT ANCHORING AND LIFTING METHOD.....	114
6.5.1 - FORKLIFT HANDLING METHOD.....	115
6.5.2 - FRAME HANDLING.....	118
6.5.3 - HANDLING OF THE ANALYSIS MODULE.....	118
6.5.4 - PNEUMATIC PANEL HANDLING.....	119
6.5.5 - FIELD DISPLAY HANDLING	119
6.6 - PACKAGING REMOVAL.....	120
6.6.1 - PACKAGING DISPOSAL	120
6.7 - STORAGE AND ENVIRONMENTAL CONDITIONS	121

7 - INSTALLATION 123

7.1 - GENERAL WARNINGS	123
7.2 - INSTALLATION PRE-REQUISITES	123
7.2.1 - ENVIRONMENTAL CONDITIONS ALLOWED	123
7.3 - EQUIPMENT NEEDED FOR INSTALLATION	124
7.4 - CHECKS BEFORE INSTALLATION	125
7.5 - SPECIFIC SAFETY INSTRUCTIONS FOR THE INSTALLATION PHASE	126
7.6 - ACQUISITION MODULE INSTALLATION DIAGRAM	127
7.7 - INSTALLATION PROCEDURE	129
7.7.1 - PRELIMINARY OPERATIONS	129
7.7.2 - EQUIPMENT INSTALLATION PROCEDURE	130
7.7.3 - INSTALLATION OF THE ACQUISITION MODULE FOR HAZARDOUS AREAS	133
7.7.4 - INSTALLATION OF THE PNEUMATIC PANEL IN A HAZARDOUS AREA	134
7.7.5 - FIELD DISPLAY (IM) INSTALLATION FOR SAFE AREA	135

8 - CONFIGURATION 137

8.1 - SAFETY REQUIREMENTS FOR CONFIGURATION	137
8.2 - EQUIPMENT CONFIGURATION	137
8.3 - VERIFY CORRECT CONFIGURATION	137
8.4 - COMMISSIONING ACTIVITIES	138

9 - MAINTENANCE AND FUNCTIONAL CHECKS 141

9.1 - GENERAL WARNINGS	141
9.2 - ROUTINE MAINTENANCE	144
9.2.1 - FILTER REPLACEMENT PROCEDURE	144
9.1 - PERIODIC VERIFICATION PROCEDURE.....	145

10 - TROUBLESHOOTING 147

10.1 -GENERAL WARNINGS	147
10.2 -OPERATOR QUALIFICATION SPECIFICATION.....	148
10.3 -TROUBLESHOOTING PROCEDURES	148

11 - UNINSTALLATION AND DISPOSAL 149

11.1 -GENERAL SAFETY WARNINGS	149
11.2 -QUALIFICATION OF THE OPERATORS IN CHARGE	149
11.3 -UNINSTALLATION	149
11.4 -INFORMATION REQUIRED IN CASE OF NEW INSTALLATION	150
11.5 -INFORMATION REQUIRED IN CASE OF RE-INSTALLATION	150
11.6 -DISPOSAL INFORMATION	150

12 - RECOMMENDED SPARE PARTS 151

12.1 -GENERAL WARNINGS	151
12.2 -HOW TO REQUEST SPARE PARTS	151
12.3 -SPARE PARTS LIST	152

2 - GENERAL INFORMATION

2.1 - MANUFACTURER IDENTIFICATION

Manufacturer	PIETRO FIORENTINI S.P.A.
Address	Via Enrico Fermi, 8/10 36057 Arcugnano (VI) - ITALY Tel. +39 0444 968511 Fax +39 0444 960468 www.fiorentini.com sales@fiorentini.com

Tab. 2.2.

NOTICE!

For any problems encountered with the equipment, contact the distributor of the relevant gas network.

2.2 - IDENTIFICATION OF THE PRODUCT

Equipment	GAS QUALITY ANALYZER
Product	GEDRA

Tab. 2.3.

2.3 - REGULATORY FRAMEWORK

PIETRO FIORENTINI S.P.A. with registered office in Arcugnano (Italy) - Via E. Fermi, 8/10, declares that the equipment of the series described in this manual is designed, manufactured, tested and checked in compliance with:

- OIML R140:2007
- WELMEC Guide 7.2:2022
- ISO 6976:2016
- UNI 9167-3:2020
- UNI 11885:2022
- UNI EN 1776:2016
- IEC EN 60079-1:2016
- ATEX 2014/34/EU
- IECEX
- EMC 2014/30/EU

NOTICE!

For specific type approvals, see the appropriate section on the Manufacturer's website: <https://www.fiorentini.com>

NOTICE!

The declaration of conformity in its original version is delivered together with the equipment.

2.4 - WARRANTY

PIETRO FIORENTINI S.P.A. guarantees that the equipment was manufactured using the best materials, with high quality workmanship, and complies with the quality requirements, specifications and performance set out in the order. The warranty shall be considered null and void and PIETRO FIORENTINI S.P.A. shall not be liable for any damage and/or malfunctions:

- due to any acts or omissions of the purchaser or end-user, or any of their carriers, employees, agents, or any third party or entity;
- in the event that the purchaser, or a third party, makes changes to the equipment supplied by PIETRO FIORENTINI S.P.A. without the prior written approval of the latter;
- in the event of failure by the purchaser to comply with the instructions contained in these instructions, as provided by PIETRO FIORENTINI S.P.A.

NOTICE!

The warranty conditions are specified in the commercial contract.

2.5 - ADDRESSEES, SUPPLY AND STORAGE OF THE MANUAL

The instruction manual is intended for qualified operator responsible for using and managing the equipment throughout its service life.

It contains the necessary information to properly use the equipment and keep its functional and qualitative characteristics unchanged over time. All information and warnings for safe, correct use are also provided.

The manual, as well as the declaration of conformity and/or test certificate, is an integral part of the equipment and must always accompany it whenever it is moved or resold. It is the responsibility of the authorised professionals (reference paragraph 2.10) to operate and manage the equipment.

WARNING!

Removing, rewriting or editing the pages of the manual and their contents is not allowed. PIETRO FIORENTINI S.p.A. shall not be held liable for any damage to people, animals and property caused by failure to adhere to the warnings and operating procedures described in this manual.

2.6 - LANGUAGE

The original manual has been drawn up in Italian.

Any translations into additional languages are to be made from the original instruction manual.

HAZARD!

The translations into other languages cannot be fully verified. If any inconsistency is found, please refer to the text of the original manual.





If inconsistencies are found or the text does not make sense:

- stop any actions;
- contact immediately PIETRO FIORENTINI S.p.A. at the addresses given in paragraph 2.1 ("Manufacturer identification").

WARNING!

PIETRO FIORENTINI S.p.A. shall be held liable for the information provided in the original manual only.

2.7 - SYMBOLS USED IN THE MANUAL

Symbol	Definition
	Symbol used to identify important warnings for the safety of the operator and/or equipment.
	Symbol used to identify the presence of a non-visible electrical hazard (surfaces, equipment or areas), contact with which can cause electrocution, burns or other serious accidents to the operator.
	Symbol used to identify information of particular importance in the manual. The information may also concern the safety of the personnel involved in using the equipment.
	Obligation to consult the instruction manual/booklet. Indicates a requirement for the personnel to refer to (and understand) the operating and warning instructions of the machine before working with or on it.

Tab. 2.4.

HAZARD!

Alerts to a hazard with a high level of risk, an imminent hazardous situation which, if not prevented, will result in death or severe damage.

WARNING!

Alerts to a hazard with a medium level of risk, a potentially hazardous situation which, if not prevented, may result in death or severe damage.

ATTENTION!

Alerts to a hazard with a low level of risk, a potentially hazardous situation which, if not prevented, could result in minor or moderate damage.

NOTICE!

Alerts to specific warnings, directions or notes of particular concern, that are not related to physical injury, as well as practices for which physical injury is not likely to occur.

2.8 - EQUIPMENT GLOSSARY

Term	Description
Field display	Device installed in a safe area, equipped with a 7" capacitive display, which allows local operation and viewing of analysis data in real time
GEDRA	Acronym for Gas Energy Density Raman Analyzer, is a gas quality (AQ) analyzer with class A accuracy according to the OIML R140 standard
Analysis unit	The section of components subject to metrological approval that is housed inside an Exd enclosure installed in a hazardous area
Pneumatic panel	Panel located in a hazardous area, composed of valves, pressure regulators, pressure gauges and fittings, which allow the control and monitoring of the flow of sampled gas
Acquisition module	Term used to identify the set of pneumatic panel and analysis cell
Anti-tampering seals	Metrological seals to be applied in the analysis unit
CRC	Acronym for Cyclic Redundancy Check, which is a numeric value generated by an algorithm that verifies the integrity of the ANL software data
ANL Software	Acronym for Analysis
WIW Software	Acronym for Web Interface Window
Reference temperature T1	Combustion temperature at which a fuel begins to burn (defined according to UNI EN 6976)
Reference temperature T2	Volume measurement temperature at which the volume of the fuel is measured (defined according to UNI EN 6976)

Tab. 2.5.

2.9 - UNIT OF MEASUREMENT

Type of measurement	Unit of measurement	Description
Consumption and Volumetric flow rate	Sm ³ /h	Standard cubic metres per hour
	Sm ³	Standard cubic metres
	m ³ /h	Cubic metres per hour
	m ³	Cubic metres
Pressure	bar	Bar
	”wc	Water column inch
	Pa	Pascal
Temperature	°C	Degree centigrade
	K	Kelvin
Tightening torque	Nm	Newton metre
Other measurements	V	Volt
	W	Watt
	Ω	Ohm
	J/m ³	Joules per cubic meter
	kWh/m ³	Kilowatt hours per cubic meter
	kcal/m ³	Kilocalorie per cubic meter

Tab. 2.6.

2.10 - QUALIFIED PROFESSIONAL FIGURES

Qualified operators entrusted with the use and operation of the equipment in all its technical life stages for the use for which it was supplied:

Professional figure	Definition
<p style="text-align: center;">Installer</p>	<p>Qualified operator able to:</p> <ul style="list-style-type: none"> • handle materials and equipment. • carry out all the operations necessary to properly install the equipment safely; • perform all the operations necessary to properly operate the equipment and system safely; • be able to perform all the operations necessary to uninstall and subsequently dispose of the equipment in compliance with the regulations in force in the country of installation.
<p style="text-align: center;">User's specialised/ technician</p>	<p>Trained and authorised technician on the management and use of the equipment, who must:</p> <ul style="list-style-type: none"> • be able to perform all operations required for the proper functioning of the equipment and the system, and for their safety and that of any third parties present; • perform maintenance on all parts of the equipment subject to maintenance (board and batteries); • access all device parts for visual inspection, checking equipment status, making adjustments and calibrations; • have proven experience in properly using the equipment similar to that described in this manual, and be trained, informed and instructed in this regard.

Tab. 2.7.

2.11 - IDENTIFICATION PLATES APPLIED TO THE EQUIPMENT

2.11.1 - ATEX/IECEX PLATE

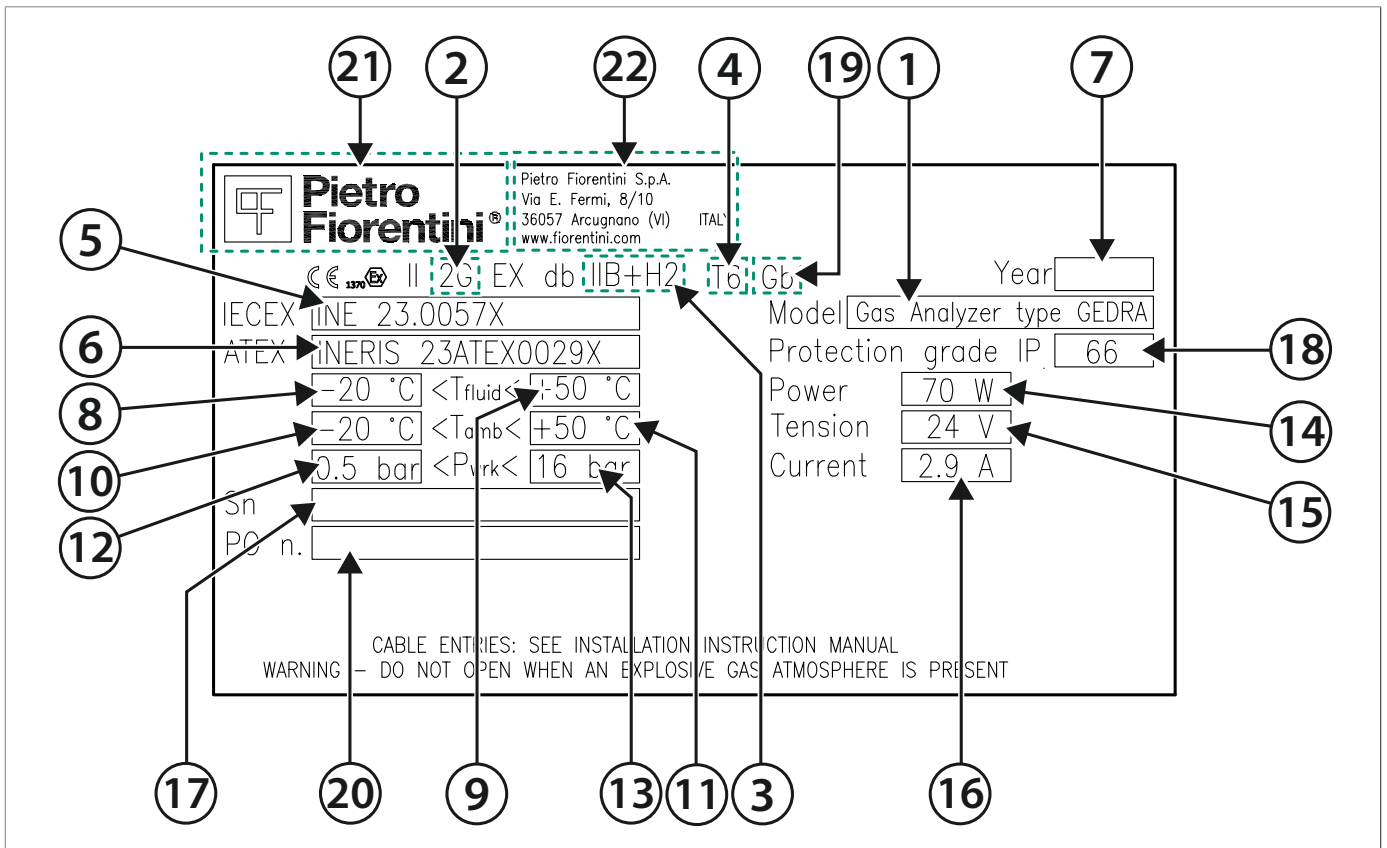

Fig. 2.1. ATEX/IECEx plate

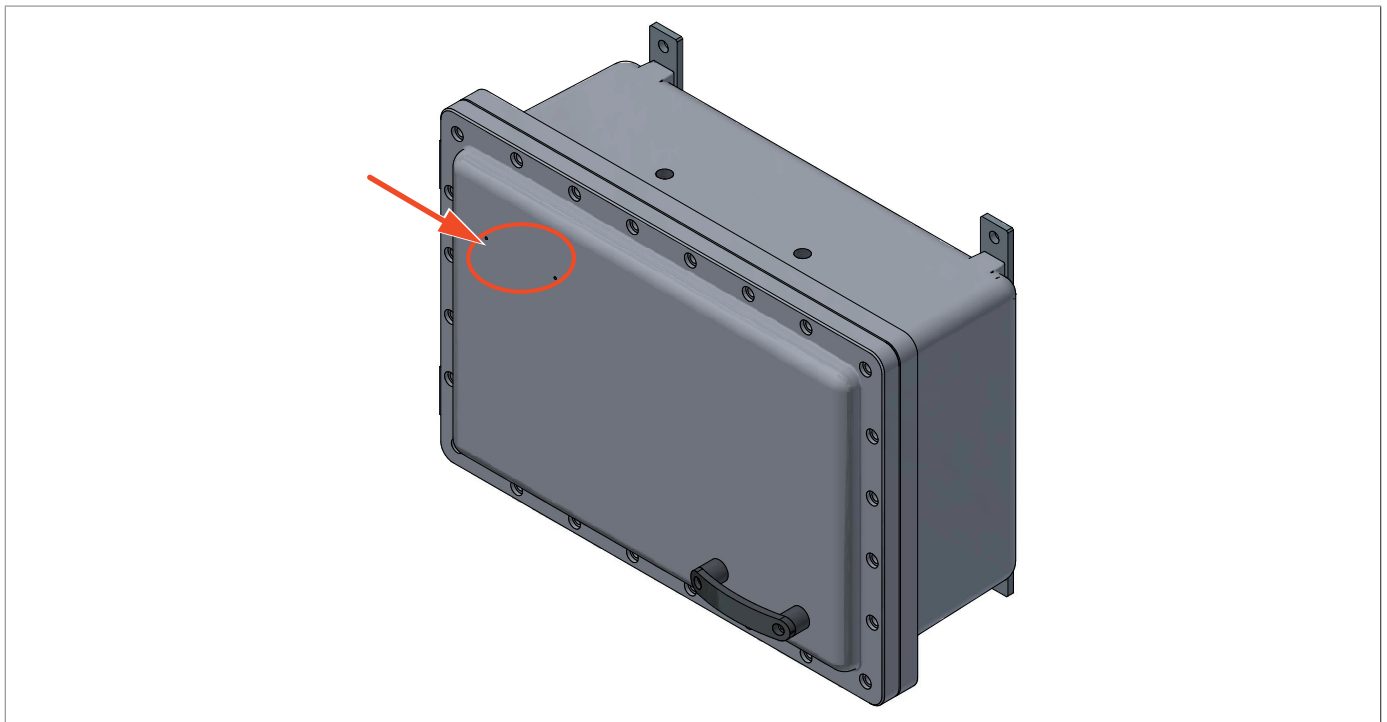

Fig. 2.2. ATEX/IECEx plate location

The ATEX/IECEX identification plate is located on the front of the Ex-d enclosure of the analysis cell located in a hazardous area.

The following information, described in Tab. 2.8, is shown on the nameplate:

Pos.	Description
1	Model name.
2	Equipment category.
3	Gas classification.
4	Temperature class.
5	IECEX certificate number.
6	ATEX certificate number.
7	Year of manufacture.
8	Minimum fluid temperature.
9	Maximum fluid temperature.
10	Minimum ambient temperature.
11	Maximum ambient temperature.
12	Minimum operating pressure.
13	Maximum operating pressure.
14	Maximum power consumption.
15	Work voltage.
16	Maximum current consumption.
17	Serial number.
18	IP (Ingress Protection) rating indicates the resistance of a device to the ingress of solids and liquids.
19	Equipment Protection Level.
20	Purchase order number.
21	Manufacturer identifier.
22	Manufacturer's address.

Tab. 2.8.

2.11.2 - METROLOGICAL PLATE

The plate below contains all the metrological information indicated on the OIML R140 certificate, which establishes the international standards for measuring instruments used in gas and energy management.

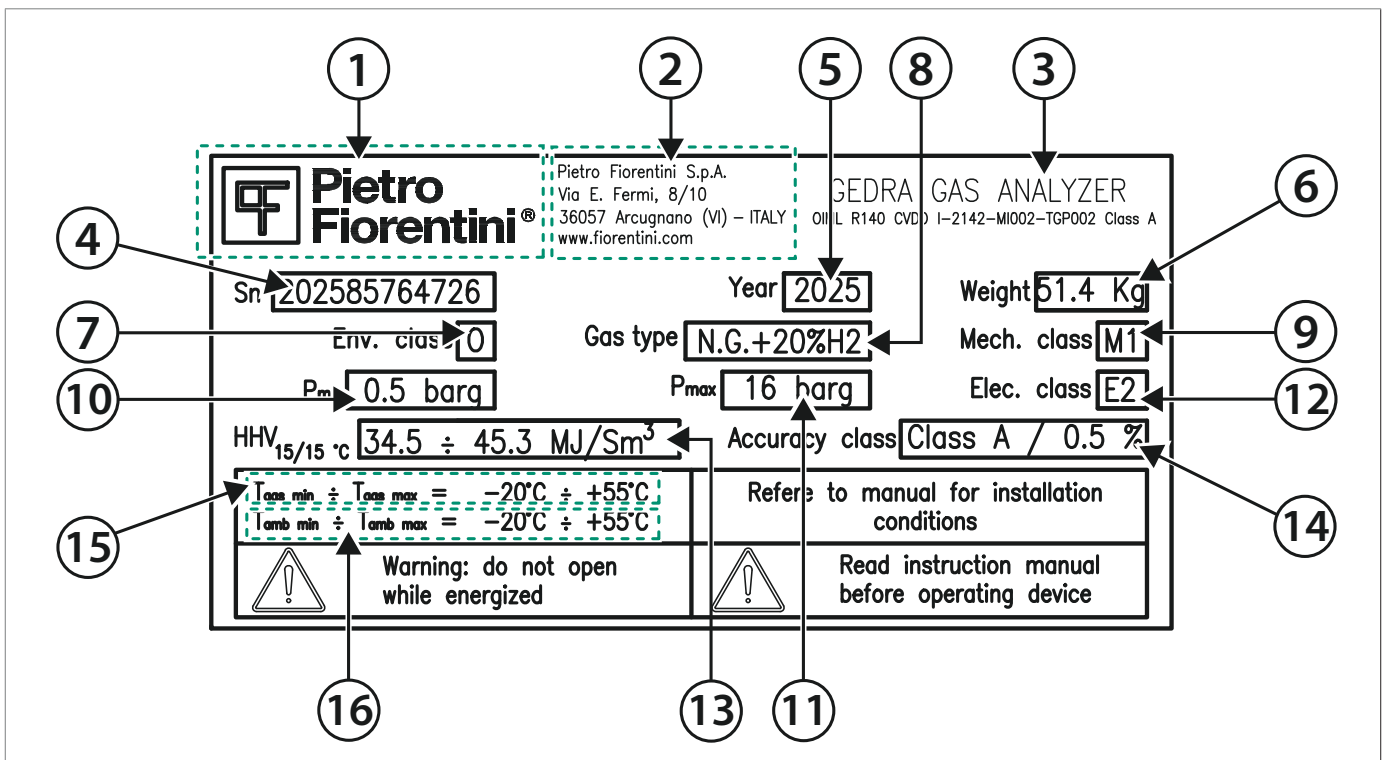

Fig. 2.3. OIML plate

The OIML identification plate contains the information described in Fig. 2.3:

Pos.	Description
1	Manufacturer identifier.
2	Manufacturer's address.
3	Certificate identifier.
4	Gedra serial number.
5	Year of manufacture.
6	Weight.
7	Climate class (OIML R140, Annex A).
8	Nature of the measured gas.
9	Mechanical class.
10	Minimum gas pressure.
11	Maximum gas pressure.
12	Electric class.
13	Higher Heating Value.
14	accuracy class.
15	Gas temperature range.
16	Ambient temperature range.

Tab. 2.9.

2.11.3 - FIELD DISPLAY IDENTIFICATION PLATE

 **HAZARD!**

Electrical risk.

Connection, testing/checking and maintenance operations must be carried out exclusively by specialized and authorized personnel (electrical maintenance technician or electrician).

Do not open live.

On the identification plate (Fig. 2.4) of the Field Display shows the information described in Tab. 2.10:

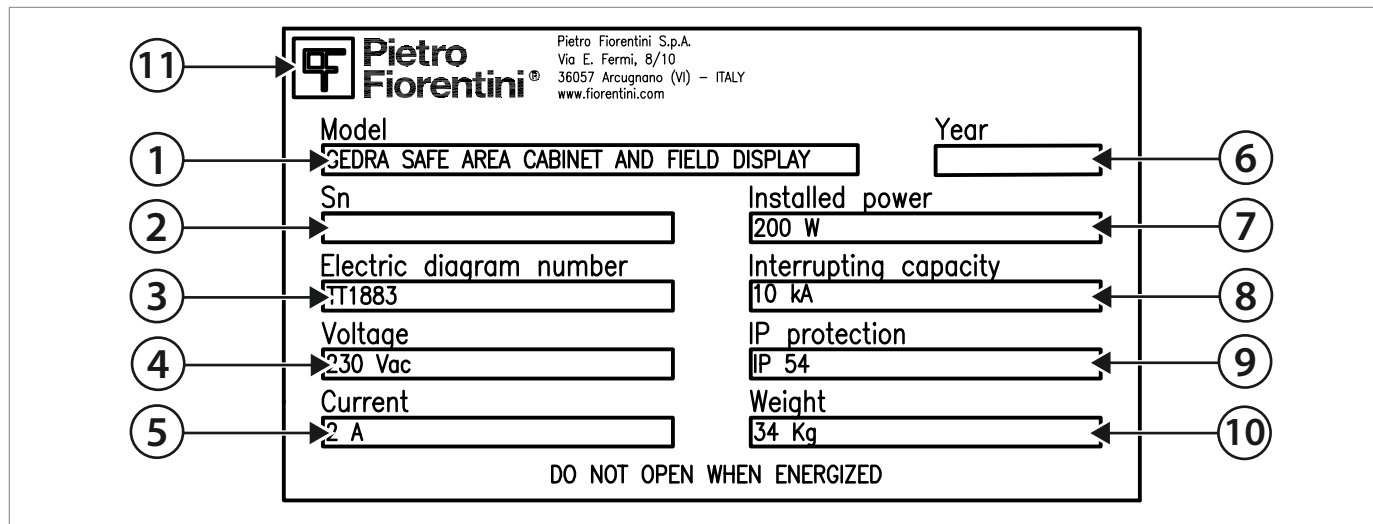

Fig. 2.4. Field Display Plate

Pos.	Description
1	Model identifier.
2	Serial number.
3	Reference wiring diagram number.
4	Electrical voltage.
5	Current.
6	Year of installation.
7	Installed power.
8	Breaking power. Indicates the maximum current that the protective devices inside the Field Display are able to interrupt in the event of a fault without damaging themselves.
9	IP (Ingress Protection) rating indicates the resistance of a device to the ingress of solids and liquids.
10	Weight.
11	Manufacturer's identifier (and address).

Tab. 2.10.

The Field Display also features a label with a symbol indicating the presence of voltage and the resulting electrical risk:

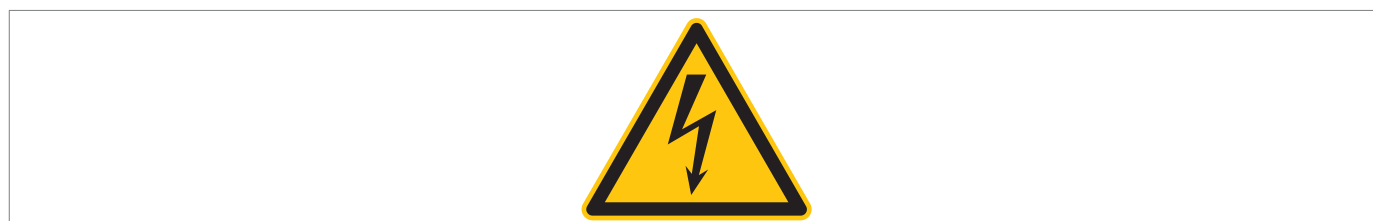

Fig. 2.5. Live voltage

PAGE INTENTIONALLY LEFT BLANK

3 - SAFETY

3.1 - GENERAL SAFETY WARNINGS

WARNING!

The equipment described in this manual is normally inserted in systems carrying flammable gases (for example: natural gas).

WARNING!

If the gas used is a combustible gas, the installation area of the equipment is defined as a 'danger zone' as there are residual risks that potentially explosive atmospheres may be generated.

In "danger zones" and in the immediate vicinity, the following are required:

- there must not be any effective sources of ignition;
- no smoking.

WARNING!

- It is strictly forbidden to repair or make any modifications to the equipment.
- For information and warnings regarding replacing batteries, refer to chapter 9 in this manual.

ATTENTION!

Authorised operators must not carry out operations or services on their own initiative that do not fall within their competence.

Never operate the equipment:

- while under the influence of intoxicating substances such as alcohol;
- if you are using drugs that may slow reaction times.

NOTICE!

The employer must train and inform operators on how to behave during operations and on the equipment to be used.

Before installation, commissioning or maintenance, operators must:

- take note of the safety regulations applicable to the place of installation they are working in;
- obtain the necessary permits to operate when required;
- wear the personal protective equipment required by the procedures described in this instruction manual;
- ensure that the required collective protective equipment and safety information are available in the area they are operating in.

3.2 - ATEX AND IECEX DIRECTIVE SAFETY INSTRUCTIONS

GEDRA is an explosion-proof device suitable for use in hazardous areas Zone 1 Group IIB+H2. The installation categories are:

- II 2G Ex db IIC T6 Gb, for BARTEC Model EJC-51 and CORTEM Model EJBC-45 enclosures
- II 2G Ex db IIB+H2 T6 Gb, for all other enclosures covered by the certificate.

WARNING!

The installation of the GEDRA device must be carried out in compliance with the EN / IEC 60079-14 standard by competent and adequately trained personnel.

For the safe installation of this device, the following requirements must be met:

1. The GEDRA system must operate with the following electrical parameters:

	Standard	Maximum
Voltage [V]	24	24
Current [A]	0.75	2,9
Power [W]	18	70

Tab. 3.11.

2. The maximum inlet pressure to the analysis module is 16 barg.
3. The GEDRA equipment must be used in an ambient temperature range of $-20^{\circ}\text{C} < T_{\text{amb}} < +50^{\circ}\text{C}$.
4. The enclosure must only be opened in the absence of an explosive atmosphere.
5. When switching on the system, make sure that the enclosure is closed with the appropriate bolts and with the tightening torque indicated in the Manufacturer's certificate.
6. External earthing of the enclosure must be performed in accordance with the enclosure manufacturer's instructions.
7. **Drilling of the Ex-d box is not permitted.**
8. **The replacement of cable glands, breathing devices and flame arrestors installed on the Ex-d box is not permitted.**
9. **The Ex-d enclosure cannot be opened unless an authorised PIETRO FIORENTINI S.p.A. person is present.**

3.2.1 - ELECTROSTATIC DISCHARGES

This device is approved for installation in areas with low explosion risk (risk is only present for short periods). In these areas, sparks produced by electrostatic discharges might still generate explosions in extreme cases.

WARNING!

When installing or using this equipment, it is advisable to implement measures to protect against electrostatic discharge.

Further information can be found in EN 60079-32-1: among the possible actions, an example is using dissipative footwear and a damp cloth (>65%) during installation/maintenance operations.

NOTICE!

PIETRO FIORENTINI S.p.A. disclaims any liability resulting from the risks and consequences caused by non-compliance with these provisions.

3.2.2 - SAFETY INSTRUCTIONS FOR INSTALLATION IN HAZARDOUS AREA

This device must be installed and operated in compliance with the provisions and adjustments in force.

NOTICE!

PIETRO FIORENTINI S.p.A. shall not be liable for damage resulting from failure to comply with the instructions and from misuse.

Safety warnings

All operations on the equipment must be performed by qualified personnel.

Transformation and spare parts

Any technical change is prohibited. Use only original spare parts intended by PIETRO FIORENTINI S.p.A.

Transport

GEDRA, as a rule, should be transported inside the original packaging box provided by PIETRO FIORENTINI S.p.A.

Upon receipt of the device, examine the supplied material.

Immediately report any shipping damage.

Storage

As a rule, GEDRA should be stored in an upright position, preferably in a dry place and at room temperature (see paragraph 6.6.1).

WARNING!



- **Install the equipment in a compartment that meets the provisions in force on safety, away from any possible damage of mechanical origin, away from sources of heat or naked flames, in a dry place and protected from external agents.**
- **The shut-off valve, located on the system upstream of the device, must be opened gradually in order to allow the gas to flow regularly, without violent shocks that would damage the internal components.**
- **It is strictly forbidden to repair or make any modifications to the device.**
- **The installation, removal, and any operations must be performed by qualified personnel, in compliance with the provisions in force concerning safety.**

3.3 - PERSONAL PROTECTIVE EQUIPMENT

In Tab. 3.12, the Personal Protective Equipment (PPE) are reported and their relative description. An obligation is associated with each symbol.

Personal protective equipment means any equipment intended to be worn by the worker in order to protect them against one or several risks that are likely to threaten their safety or health during work.

For the operators in charge, depending on the type of work requested, the most appropriate PPE of the following will be reported and must be used:

Symbol	Meaning
	Obligation to use safety or insulated gloves. Indicates a requirement for the personnel to use safety or insulated gloves.
	Obligation to use safety goggles. Indicates a requirement for personnel to use protective goggles for eye protection.
	Obligation to use safety shoes. Indicates a requirement for personnel to use accident-prevention safety shoes.
	Obligation to use noise protection equipment. Indicates a requirement for the personnel to use ear muffs or ear plugs to protect their hearing.
	Obligation to wear protective clothing. Indicates a requirement for personnel to wear specific protective clothing.
	Obligation to use a protective mask. Indicates a requirement for the personnel to use respiratory masks in the event of a chemical risk.
	Obligation to use a protective helmet. Indicates a requirement for the personnel to use protective helmets.
	Obligation to wear high visibility vests. Indicates a requirement for the personnel to use high visibility vests.

Tab. 3.12.

WARNING!

Each licensed operator is obliged to:

- **take care of his/her own health and safety and that of other people in the workplace who are affected by his/her actions or omissions, in accordance with the training, instructions and equipment provided by the employer;**
- **appropriately use the PPE made available;**
- **immediately report to the employer, the manager or the person in charge any deficiencies in the equipment and devices, as well as any dangerous conditions they may become aware of.**

3.4 - OBLIGATIONS AND PROHIBITIONS

The following is a list of obligations and prohibitions to be observed for the safety of the operator.

It is mandatory:

- to carefully read and understand the use, maintenance and warning manual;
- before installing the equipment, to strictly refer to the details specified on the nameplates and in the manual;
- to avoid knocks and violent impact that could damage the equipment.

It is forbidden to:

- operate in various capacities on the equipment without the PPE indicated in the work procedures described in this manual;
- operate in the presence of open flames or bring open flames close to the work area;
- smoke near the equipment or while working on it;
- use the equipment with parameters other than those indicated on the name plate;
- use the equipment outside the operating temperature range declared on the name plate and indicated in this manual;
- install or use the equipment in environments other than those specified in this manual.

3.5 - RESIDUAL RISKS

The equipment does not present residual risks for the operator related to its normal operation.

NOTICE!

The equipment is ATEX Zone 1 Category 2G certified.

In this zone, during normal activities, the formation of an explosive atmosphere consisting of a mixture of air and flammable substances in the form of gas, vapour or mist is not likely and, if it does occur, it persists only for a short duration (from 10h to 1000).

WARNING!

If there are any functional faults, do not operate.

Immediately contact PIETRO FIORENTINI S.p.A. for the necessary directions.

3.5.1 - RISK OF ELECTROSTATIC DISCHARGE

This device is approved for installation in areas with low explosion risk (risk is only present for short periods).

Due to the gas in the atmosphere, sparks produced in these areas by electrostatic discharges might still generate explosions in extreme cases.

WARNING!

It is mandatory to implement protective measures against electrostatic discharges during installation, configuration and maintenance of the equipment.

The authorised operator must proceed as follows, during the various operational phases, to avoid the risk:

Operational phases	Obligations of the operator
Installation	<ul style="list-style-type: none"> • Wear professional safety footwear with ESD characteristics; • Wear work clothes that dissipate electrostatic charges; • Use a damp cloth for cleaning; • Use a gas detector.
Configuration	<ul style="list-style-type: none"> • Wear professional safety footwear with ESD characteristics; • Wear work clothes that dissipate electrostatic charges.
Maintenance	<ul style="list-style-type: none"> • Wear professional safety footwear with ESD characteristics; • Wear work clothes that dissipate electrostatic charges; • Use a damp cloth for cleaning; • Use a gas detector.

Tab. 3.13.

3.5.2 - RISKS FOR POTENTIALLY EXPLOSIVE ATMOSPHERES

Tab.3.14 shows the conditions that can lead to the generation of a potentially explosive atmosphere by the GEDRA quality analyser.

The table is valid for use with natural gas with a density of no more than 0.8; for different densities, the installation and environmental conditions must also be evaluated.

! WARNING!

If the gas used is a combustible gas, the installation area of the equipment is defined "danger zone" as there are residual risks of formation of potentially explosive atmospheres.

There must be no effective sources of ignition in 'danger zones' and in close proximity thereto.

Operational conditions	Normative references	Additional requirements
First start-up	Before commissioning, the external sealing of the system portion on which the equipment is installed is checked at a suitable pressure (in accordance with the provisions of standards EN 12186 and EN 12279).	The instructions for use indicate the need to meet the requirements in Standards EN 12186 and EN 12279.
Operation in normal conditions	The same applies as indicated in the previous point and furthermore the installation of the equipment is: <ul style="list-style-type: none"> outdoors or in an environment with natural ventilation (in accordance with Standards EN 12186 and EN 12279); subject to surveillance according to current national rules/good practice/the equipment manufacturer's instructions (in accordance with the provisions of Standard EN 12186 and Standard EN 12279). 	In the instructions for use: <ul style="list-style-type: none"> the environment in which the equipment is installed is indicated (in compliance with the EN 12186 and EN 12279 standards); the periodic verifications and maintenance required in accordance with the current national regulations (if any) and the manufacturer's specific recommendations are listed.
Breakage of non-metal parts (malfunction)	This type of malfunction is not reasonably expected as these are static (outward) seals.	-
Placing out of service	<ul style="list-style-type: none"> The pressure of the system section in which the equipment is installed must be reduced with appropriate vent lines channelled to a safe area (in accordance with the provisions of Standard EN 12186 and Standard EN 12279). The residual gas must be discharged as indicated above. 	The instructions for use indicate the need to meet the requirements of Standards EN 12186 and EN 12279.
Reboot	<ul style="list-style-type: none"> After reassembling the GEDRA, carry out an external leakage test at a suitable pressure value, as specified by the manufacturer. Before commissioning, the external sealing of the system portion on which the equipment is installed is checked at a suitable pressure (in accordance with the provisions of standards EN 12186 and EN 12279). 	The instructions for use indicate: <ul style="list-style-type: none"> the minimum conditions for testing external leakage; the need to meet the requirements of Standards EN 12186 and EN 12279.

Tab. 3.14.

3.6 - SAFETY AND FRAUD PREVENTION

The solutions implemented on the equipment to assure safety comply with the requirements set forth by the reference standard in force. In detail, access:

- to electronics is not possible without the removal of the mechanical metrological seals in accordance with the provisions of the legalization plan indicated in the instrument certificate;
- to the memory device is not possible without permanent and obvious damage to the equipment;
- to the temperature sensor is not possible without permanent and obvious damage to the equipment;
- to the flow shut-off valve is not possible without permanent and obvious damage to the equipment

The attempts:

- to tamper with proper operation of the meter are detected and recorded in the Metrological Events Log;
- by unauthorised personnel to access the meter through the communication channels which it is equipped with are detected and recorded in the Metrological Events Log;
- to access the meter through the communication channels made with wrong passwords or encryption keys are detected, listed and made available to the control centre.

If a seal is removed, contact the facility owner.

NOTICE!

- **Using the interface devices normally available to the user, only data consultation activities can be carried out and no configuration can be performed;**
- **The configurations that can be performed through the communication channels which the device is equipped with which can only be carried out by authorised personnel leave a track since they are stored in the appropriate memory log (Metrological Events Log).**

Furthermore:

- the commands sent by external devices through the communication channels that it is equipped with are verified in terms of source authenticity;
- the messages transmitted through the communication channels conveying sensitive information are all efficiently encrypted;
- the duration of the conditions is monitored and recorded by the firmware.

3.7 - SAFETY PICTOGRAMS

The equipment and/or packaging PIETRO FIORENTINI S.p.A. may display the safety pictograms described in Tab. 3.15:

Symbol	Definition
	Symbol used to identify a GENERIC HAZARD.
	Symbol used to identify DANGERS GENERATED BY STATIC ELECTRICITY.
	Symbol applied to the packaging to identify the type of danger and risks related to the transported product, based on the classification of the European ADR agreement. Class 9 (Various dangerous substances). ADR - UN3090 (lithium metal batteries).
	The symbol indicates that the product must not be disposed of as unsorted waste but must be sent to separate collection facilities for recovery and recycling.

Tab. 3.15.

WARNING!

It is absolutely forbidden to remove or alter the safety pictograms on the equipment or the packaging.

3.8 - NOISE LEVEL

GEDRA has no moving parts.

For the value of the noise generated by the equipment and further information, contact PIETRO FIORENTINI S.p.A.

ATTENTION!

The obligation to use earmuffs or ear plugs to protect the hearing of qualified professional figures (reference paragraph 2.10) remains in the event that the noise in the installation environment of the equipment (depending on specific operating conditions) exceeds the value of 85 dBA.

PAGE INTENTIONALLY LEFT BLANK

4 - DESCRIPTION AND OPERATION

4.1 - GENERAL DESCRIPTION

The equipment GEDRA (Gas Energy Density Raman Analyzer) is a gas quality analyser, with accuracy class A, according to OIML R140 standard. Using the principle of Raman spectroscopy, according to ISO 6976, it measures:

- higher calorific value
- lower calorific value
- upper Wobbe index
- lower Wobbe index
- molar mass
- compressibility factor (Z)
- molar volume
- relative density
- density
- various GAS:

Gas components detected in the mixture	Molar titration measurement range (in %)	
	Minimum value	Maximum value
Methane CH ₄	70	100
Carbon Dioxide CO ₂	0	4
Ethane C ₂ H ₆	0	20
Propane C ₃ H ₈	0	4
Isobutane i-C ₄ H ₁₀	0	4
n-Butane C ₄ H ₁₀	0	4
Nitrogen N ₂	0	10
Hydrogen H ₂	0	20

Fig. 4.6. Table of detected GASes

Data communication and transmission are managed in accordance with the UNI 11885 standard.

Product innovation is based on the integration of the following aspects:

- does not require the use of additional cylinders (carrier gas or calibration gas)
- does not release gas into the atmosphere, the gas returns to the network after analysis
- hydrogen reading up to 20%.

4.2 - SYSTEM ARCHITECTURE

GEDRA is composed of:

- **analysis unit**, enclosed inside an Ex-d enclosure, for installations in hazardous areas
- **pneumatic panel**, necessary to treat the gas taken from the cabin pipe: the gas is filtered and reduced to the measuring pressure (maximum 16 bar), and then injected back into the pipe
- **acquisition module**, composed of the analysis unit and the pneumatic panel, can be installed on a special frame (guarantees greater flexibility during the installation phase) or on the wall
- **field display** (optional), installed in a safe area, allows you to operate locally and view analysis data. Inside the panel, the modem for remote connection is also mounted
- **connection cables**, for the following outputs in safe areas:
 - 2 Ethernet cables for Ethernet TCP/IP protocol
 - 1 multicore cable containing the RS485 Modbus serial connections
 - 1 cable to enable you to collect the digital error signal
 - 1 cable for the 24 VDC power supply of the analysis unit

The acquisition module can be installed in a risk area, using two different configurations:

- Type 1: applicable where there is a pressure drop due to the presence of a pressure regulator. This configuration allows the gas to be re-injected into the line after being analysed (Fig. 4.8)
- Type 2: applicable in the absence of a pressure jump, when a pressure regulator is not provided. This configuration allows the release of the gas into the atmosphere (Fig. 4.9).

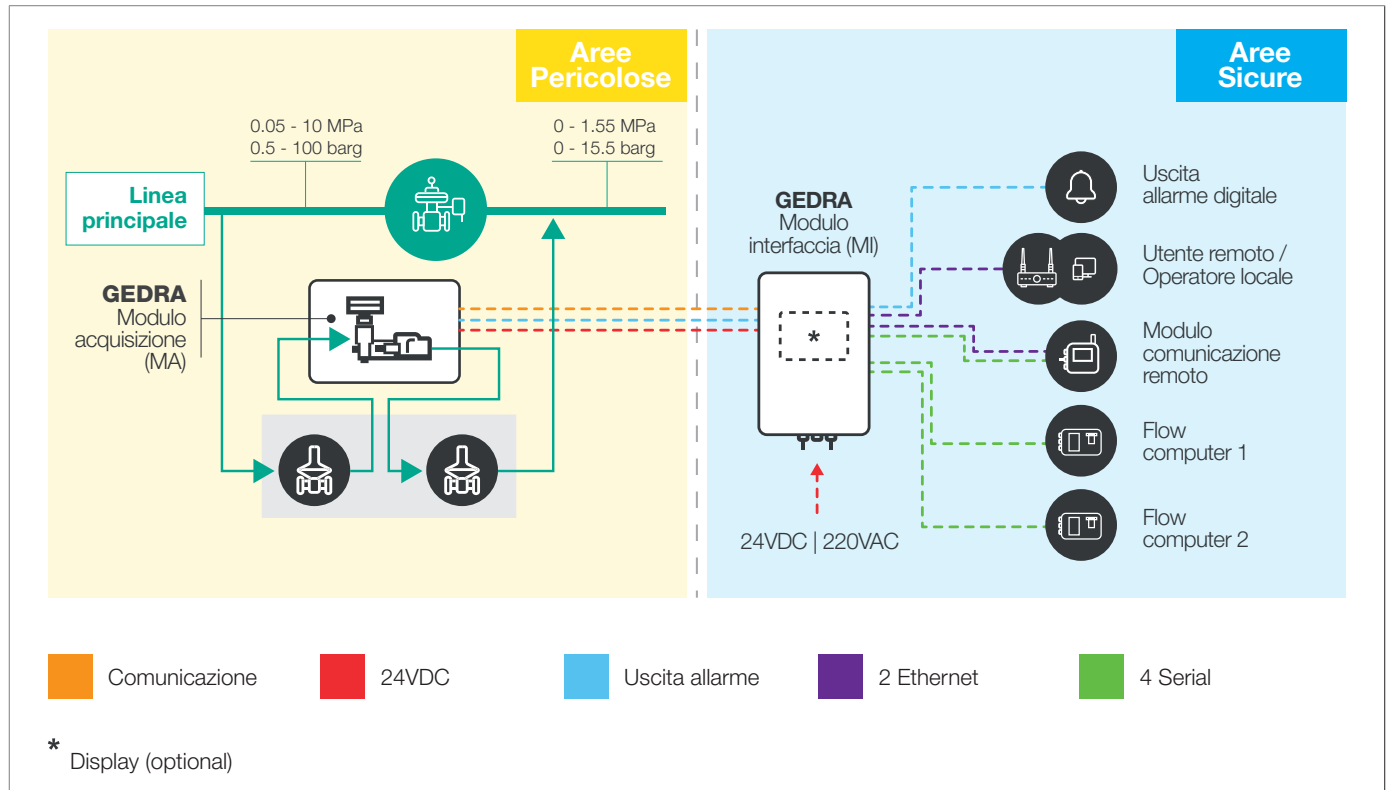

Fig. 4.7. GEDRA Architecture

Tipo 1

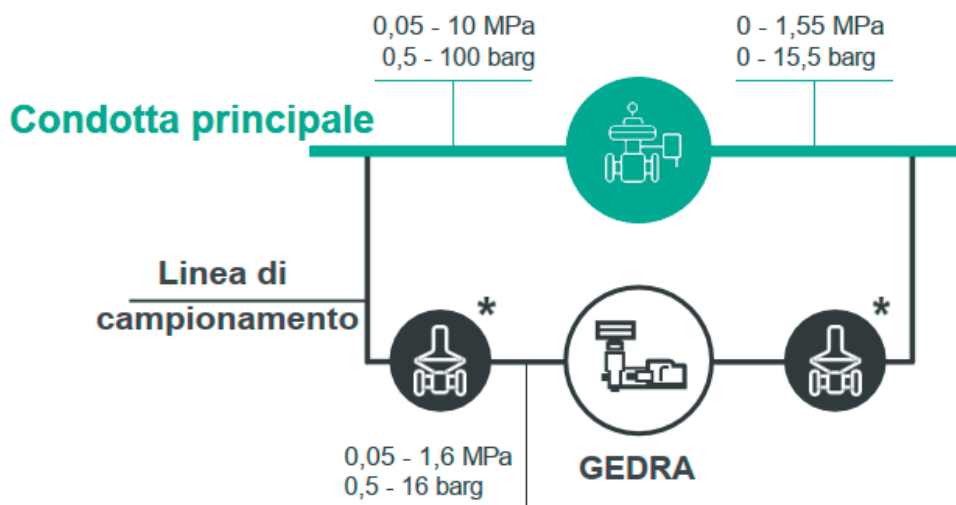

Fig. 4.8. Type 1 Configuration

Tipo 2

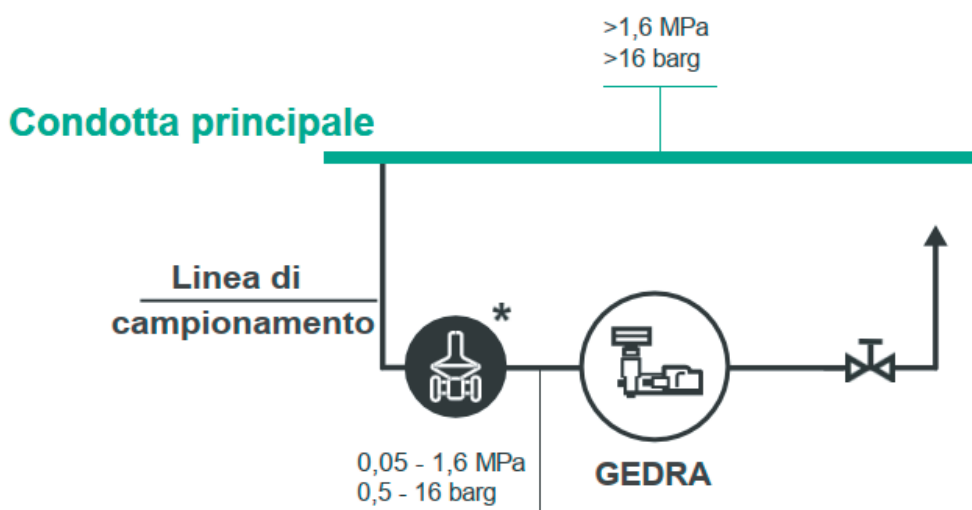

Fig. 4.9. Type 2 Configuration

4.3 - ACQUISITION MODULE

The acquisition module consists of two subassemblies: the analysis unit and the pneumatic panel.

ANALYSIS UNIT

The analysis unit consists of metrologically approved components enclosed in an Ex-d enclosure. All components within this enclosure, assembly processes, and factory calibration must be carefully tracked.

The analysis unit is connected to the Ex-e box and is equipped with terminals that allow a safe and stable connection of the electrical cables.

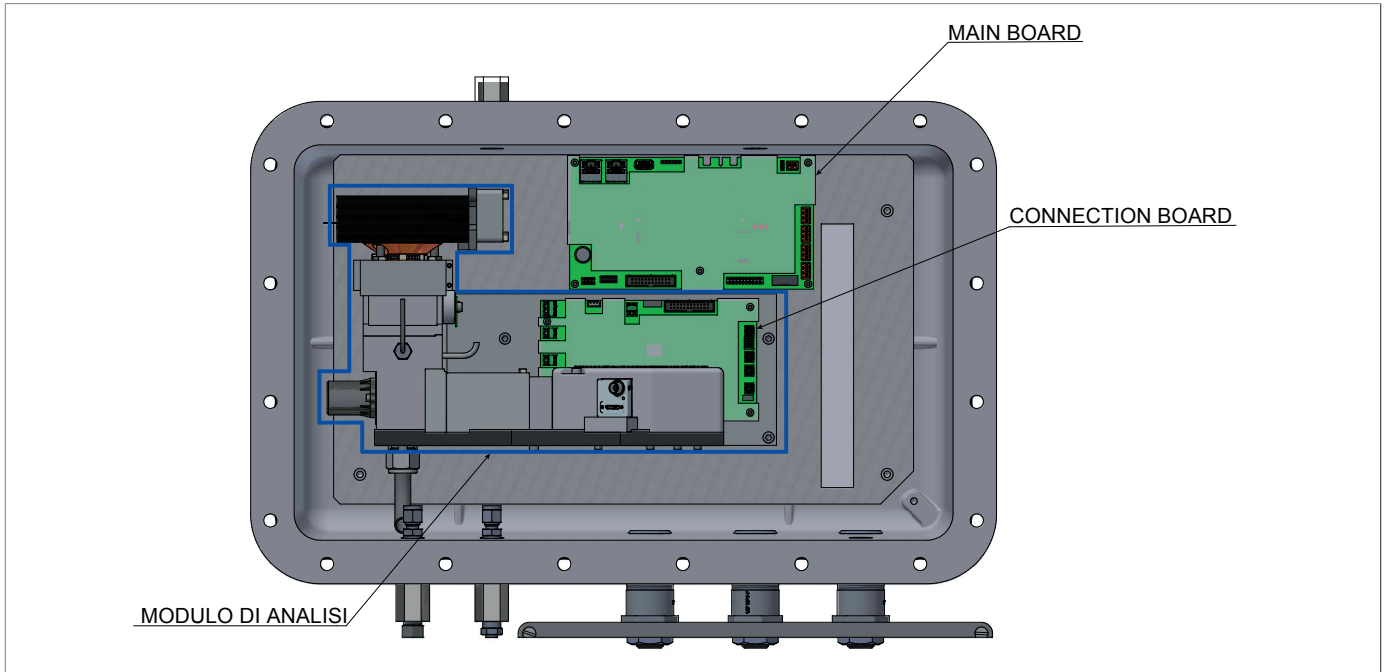

Fig. 4.10. Ex-d enclosure with analysis module

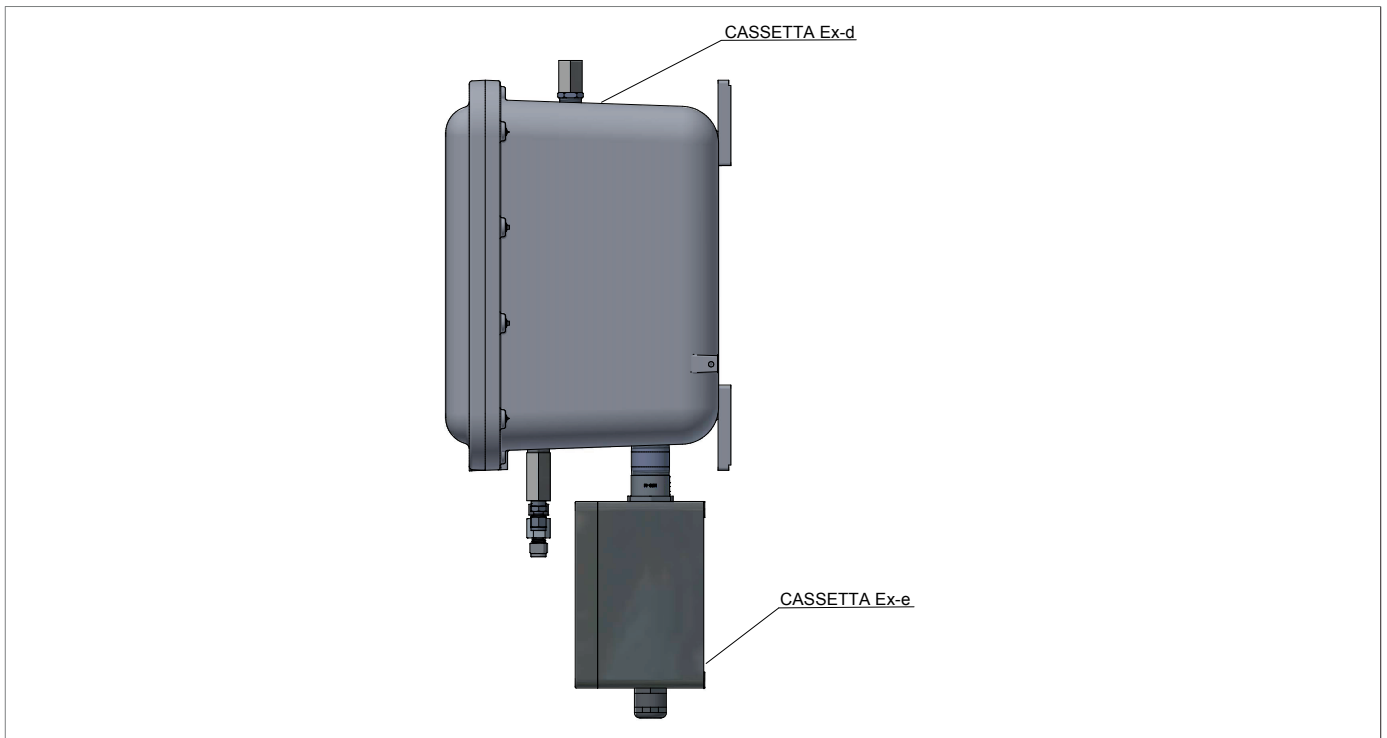

Fig. 4.11. Ex-e box

The main elements of the analysis module are:

1. **laser source**, device that emits a beam of light
2. **gas inlet**, section where the gas is channeled into the analysis cell
3. **gas outlet**, section where the gas is released from the analyser
4. **detector**, a device that collects and measures light scattered by gas samples. Light is converted into electrical signals for analysis
5. **analysis cell**, component that contains the gas sample to be analyzed.

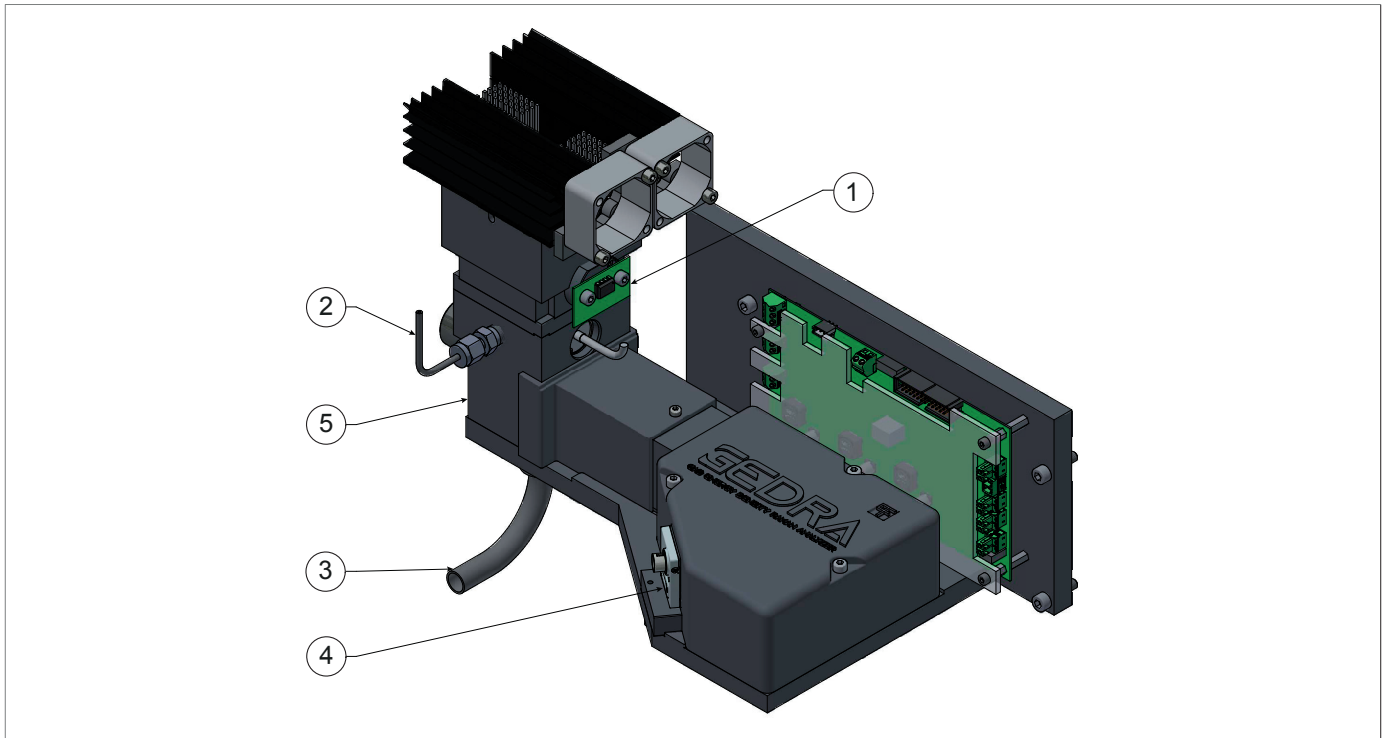

Fig. 4.12. Components of the GEDRA analysis cell

The equipment GEDRA is based on Raman spectroscopy, a technique that exploits the interaction of light with matter.

When a beam of light from a laser source hits the gas in the cell, the gas responds by scattering some of the light. A small portion of the scattered light has a particular wavelength as a result of the light's interaction with gas molecules: different molecules have a characteristic Raman emission, a fingerprint of the gas. This phenomenon is called Raman scattering.

The optical system captures the Raman scattering, divides it into wavelengths and is read by the detector. In this way, the instrument detects the signals of all components of the gas mixture simultaneously.

These signals are then separated, analyzed, and used to calculate component concentrations and calorific value.

PNEUMATIC PANEL

The pneumatic panel positioned below the analysis unit in the hazardous area (Fig. 4.13) is necessary for the sampling, treatment and stabilization preparatory to the measurement and the reinjection following the analysis of the analyzed gas.

To reinject the gas after the analysis, the GEDRA must be installed in bypass of the existing regulation, so as to take the gas upstream of the regulation and inject it downstream of the regulation.

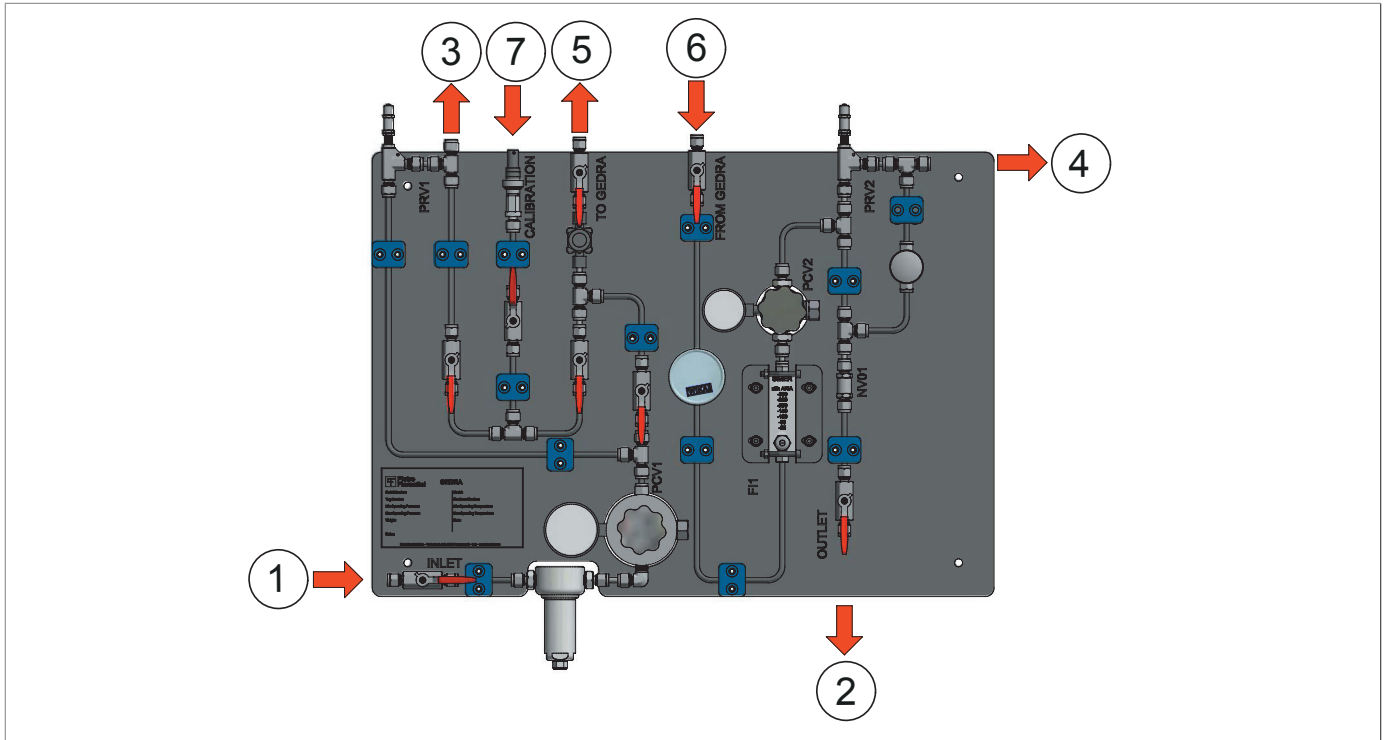

Fig. 4.13. Pneumatic panel

The connections on the panel are:

1. gas inlet from upstream pipe (4÷100 bar)
2. gas outlet towards downstream pipe (≤ 16 bar)
3. high pressure vent, used as protection for the equipment ($P_{max} 16$ bar)
4. low pressure vent, used as a safety device
5. input connection GEDRA (< 16 bar)
6. output connection GEDRA (< 16 bar)
7. calibration input, normally closed.

The pneumatic panel is secured to prevent the propagation of upstream pressure in the event of component malfunction or failure.

In the pneumatic panel with Type 1 configuration (Fig. 4.14), there are two ball valves. One valve is located at the gas inlet pipe coming from the sampling point and the other valve is located at the connection of the gas outlet pipe to be sent to the cabin.

These valves allow the pneumatic panel to be isolated from the cabin lines. Maintenance operations can be performed on the panel without intervening on the cabin line or the analysis unit.

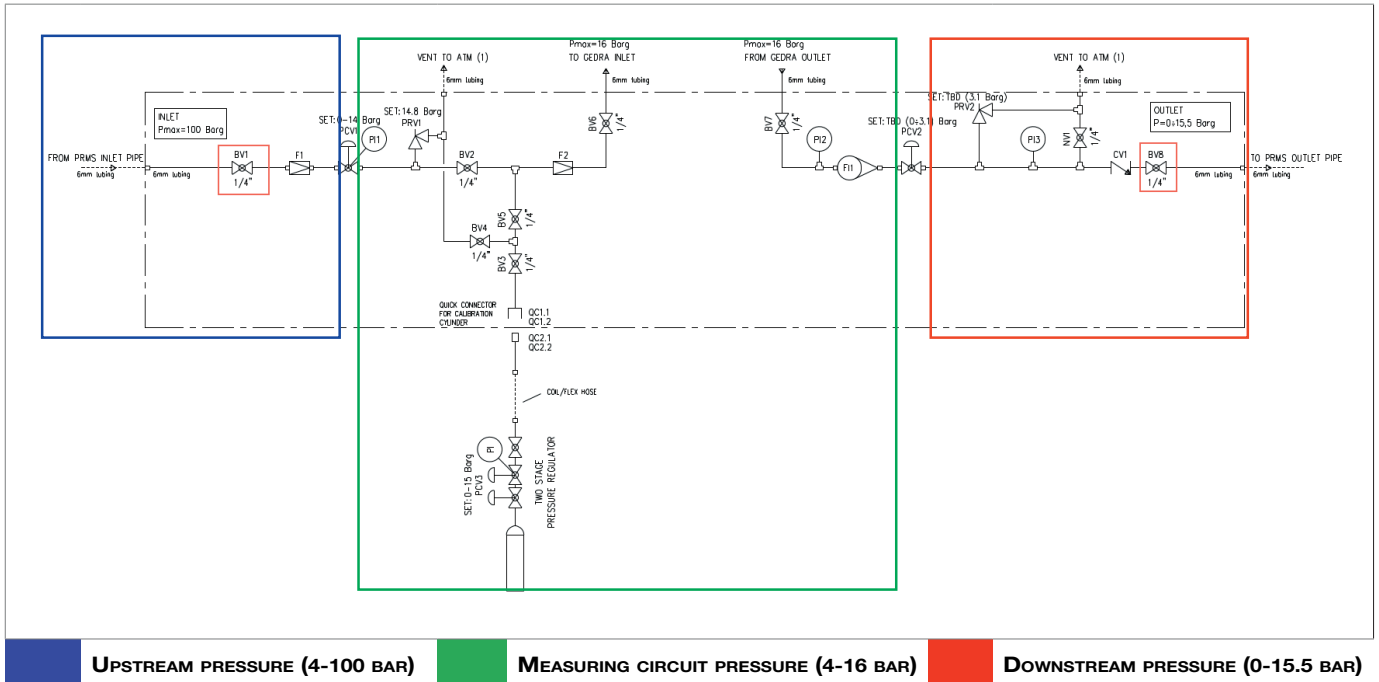

Fig. 4.14. P&ID complete pneumatic panel

There are two sections in the pneumatic panel:

- 1. inlet section in GEDRA:** identifies the gas sampling pipe, taken from the cabin pipe and sent to the GEDRA analysis module.

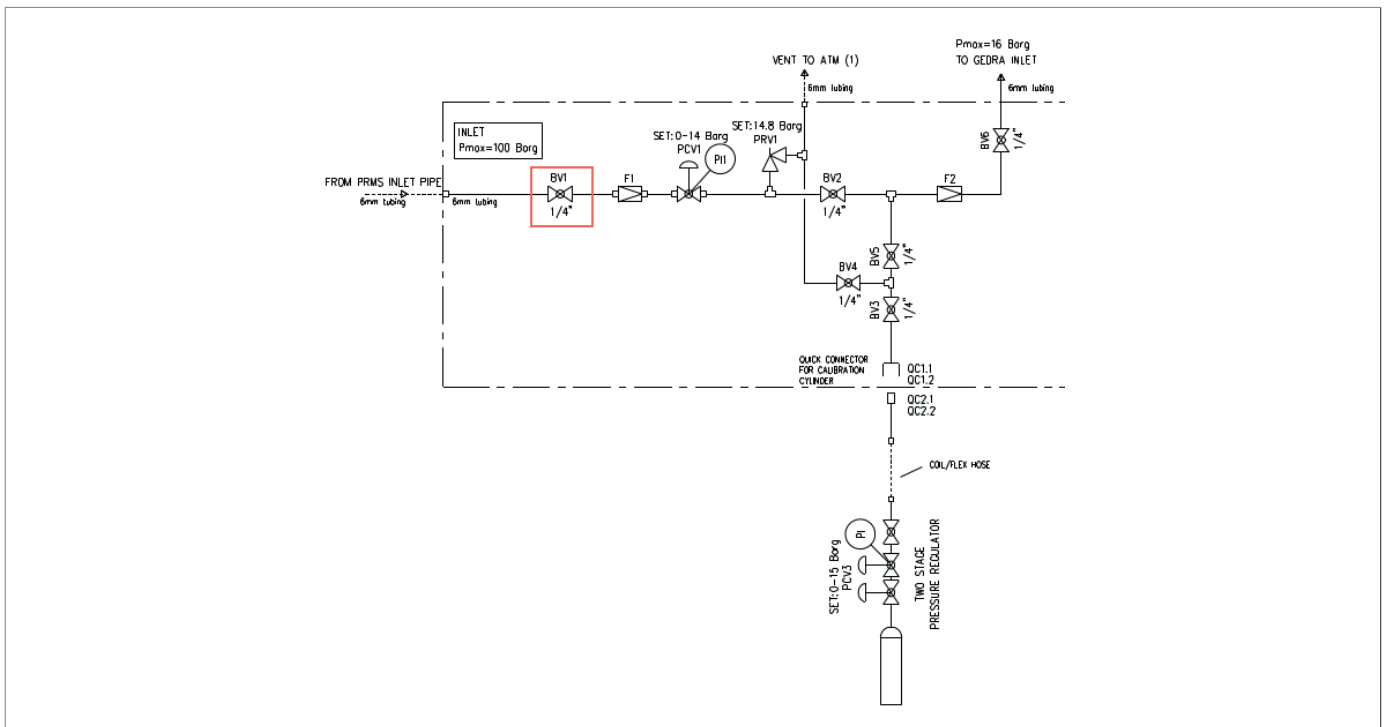

Fig. 4.15. P&ID pneumatic panel inlet section

The pneumatic inlet section is made up of:

- ball valve (BV1, BV2, BV3, BV4, BV5, BV 1/4")
- filter (F1, F2)
- safety valve to prevent the risk of overpressure (PRV1)
- pressure regulator in SS316
- quick coupling for the cylinder

2. **outlet section from GEDRA:** identifies the gas sampling pipe exiting the GEDRA analysis module, which is reinjected from the cabin line.

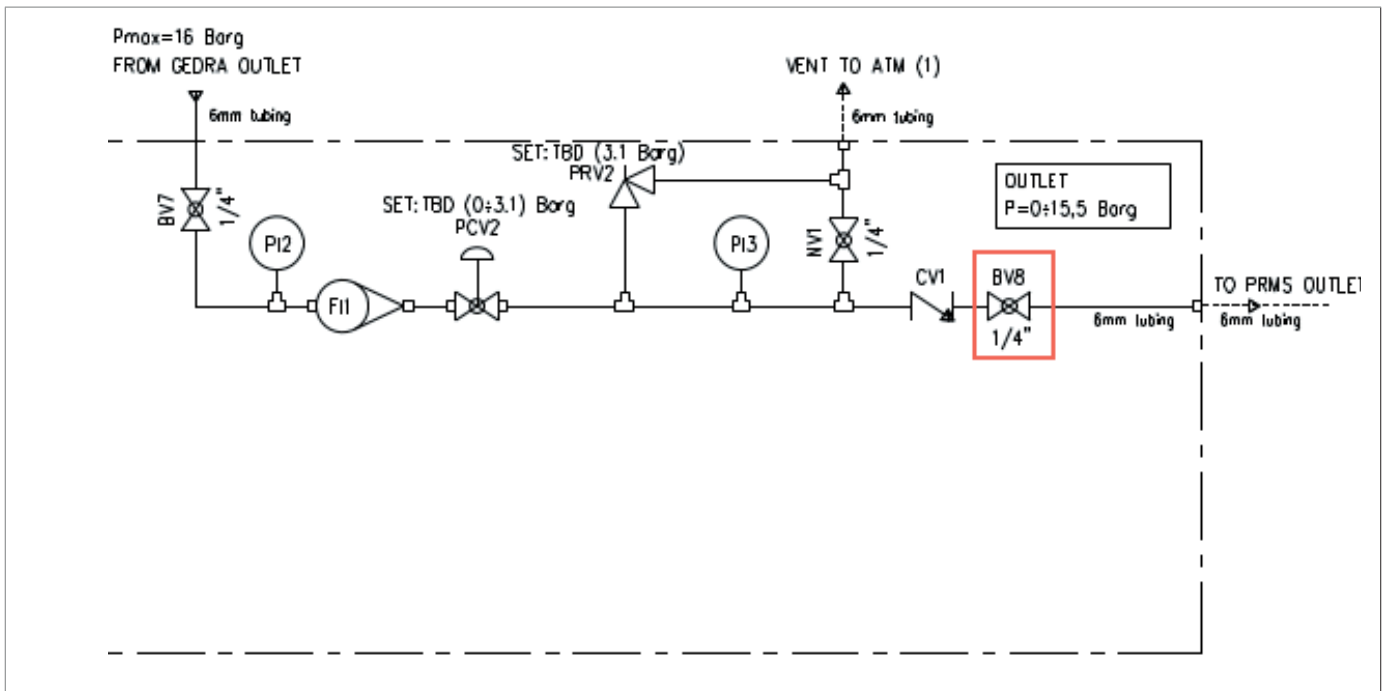

Fig. 4.16. P&ID pneumatic panel outlet section

The pneumatic outlet section is made up of:

- ball valve (BV7, B8 1/4")
- non-return valve (C1)
- safety valve to prevent the risk of overpressure (PRV2)
- pressure regulator in SS316

In the pneumatic panel with Type 2 configuration (Fig. 4.17), the inlet section in the GEDRA is the same as the Type 1 configuration. The outlet section from the GEDRA only features the ball valve (BV7).

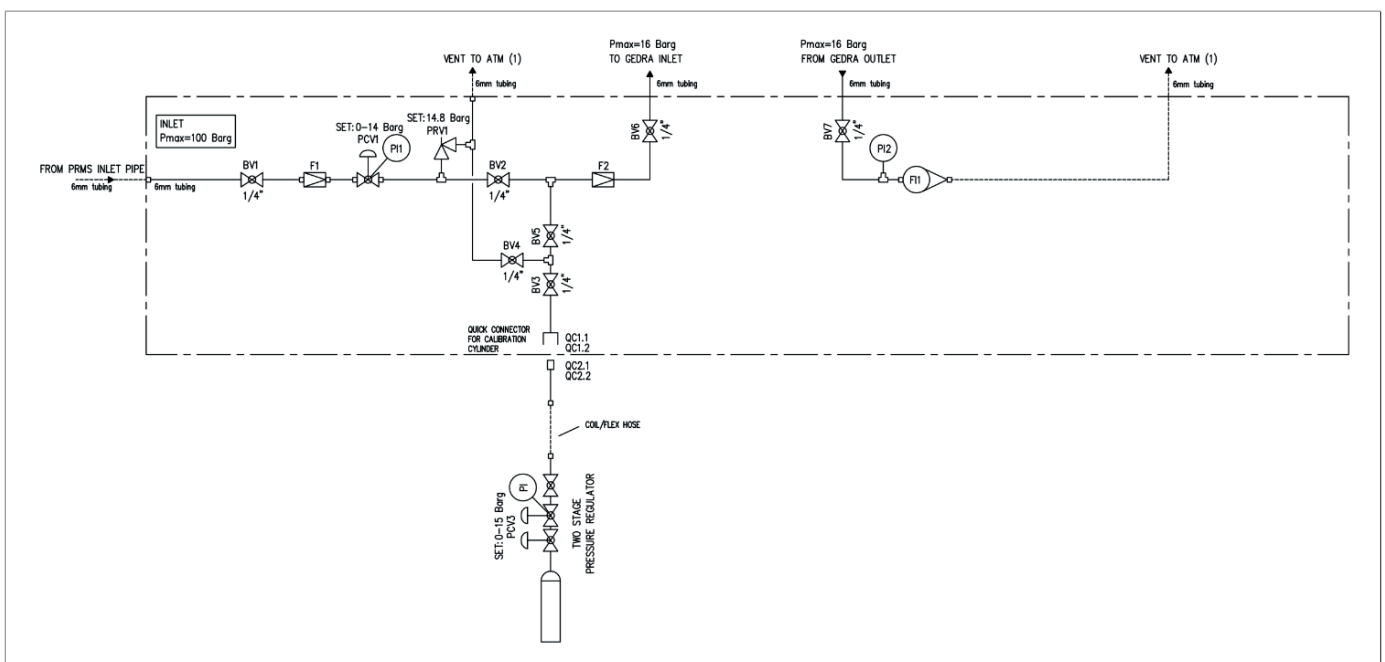

Fig. 4.17. P&ID pneumatic panel with release into the atmosphere

4.3.1 - INSTALLING THE ACQUISITION MODULE

The acquisition module can be installed:

- with an internal frame (Fig. 4.18), this method requires fixing to the ground;
- on the wall (Fig. 4.19, Fig. 4.20), this mode involves wall fixing in the upper part of the Ex-d enclosure and in the lower part of the pneumatic panel;
- with an external frame (Fig. 4.21), this method requires fixing to the ground.

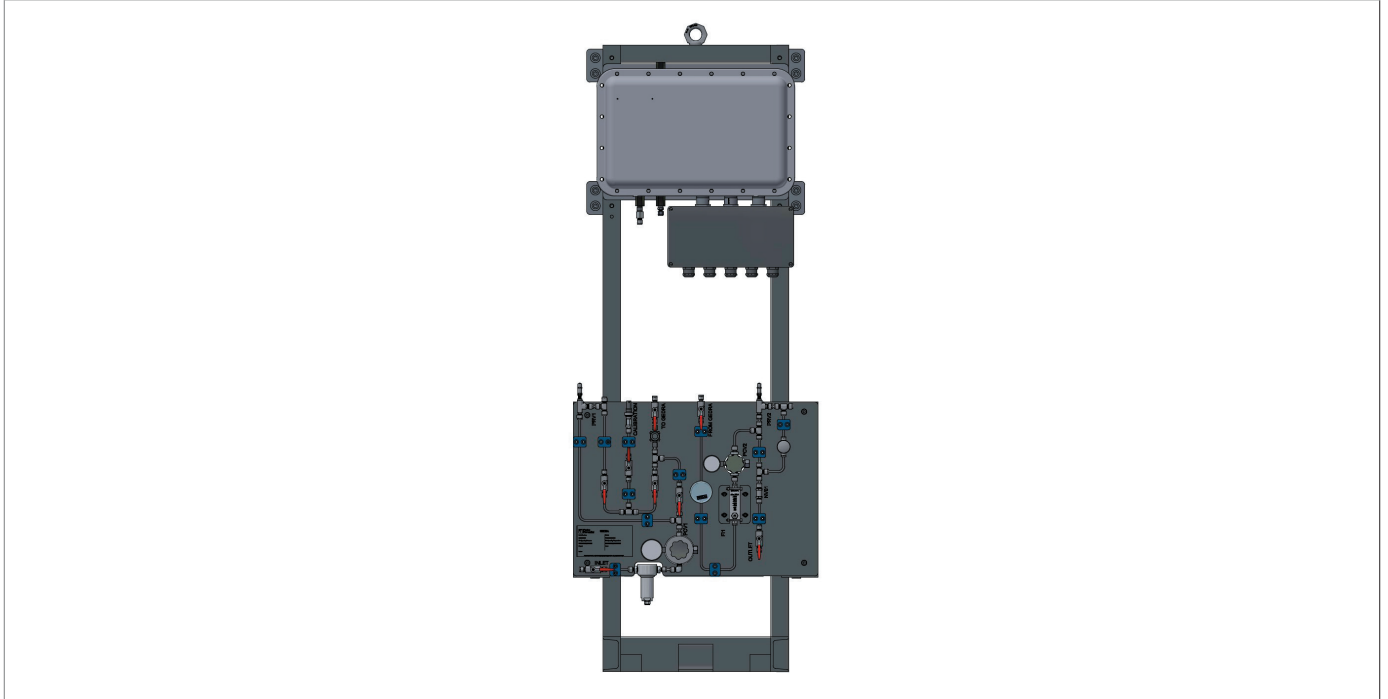

Fig. 4.18. *Indoor frame*

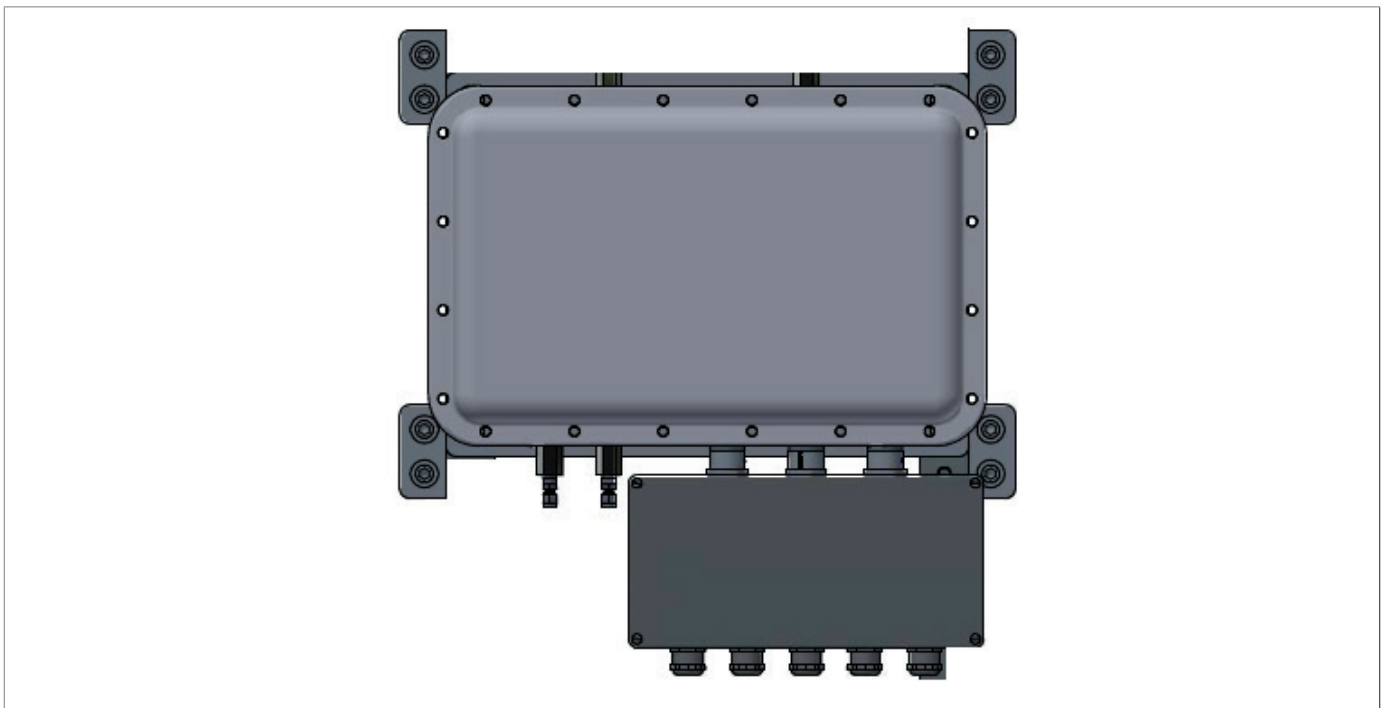

Fig. 4.19. *Wall-mounted (analysis module)*

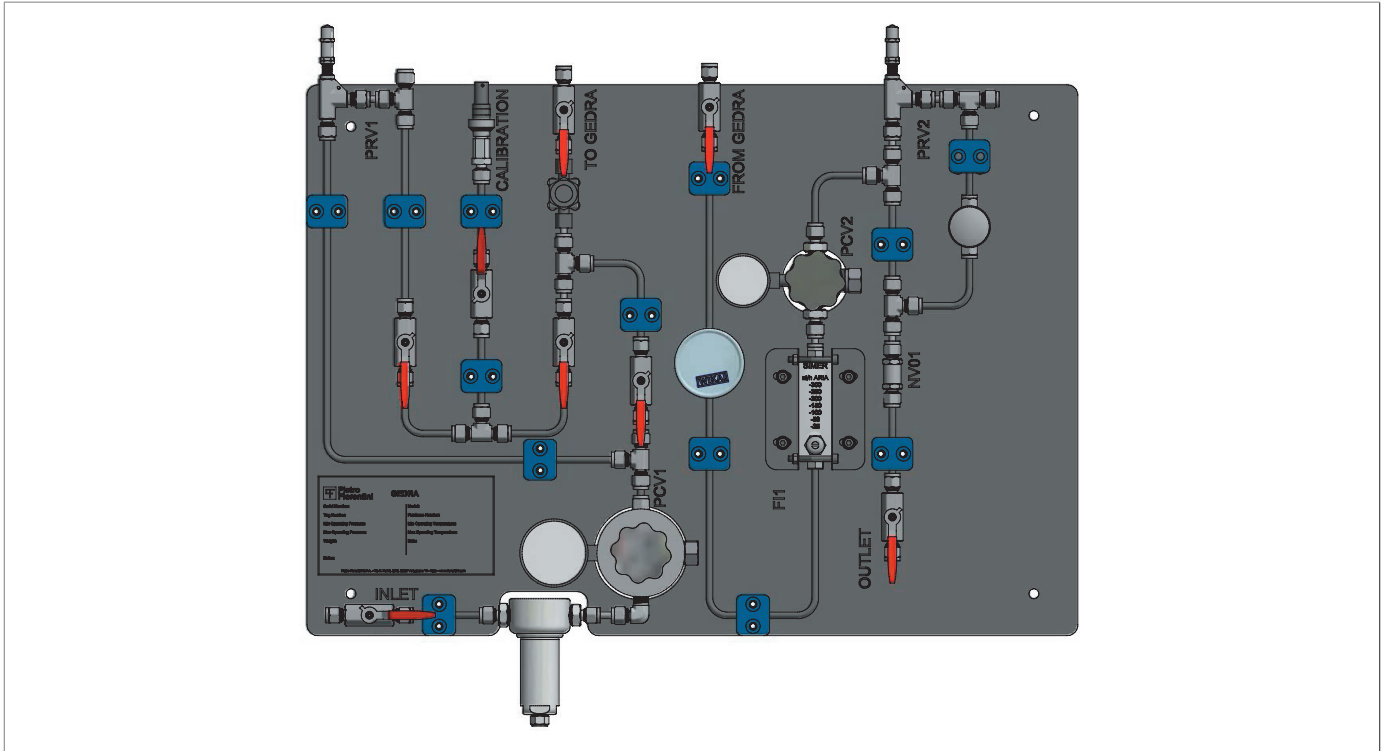

Fig. 4.20. Wall-mounted (pneumatic panel)

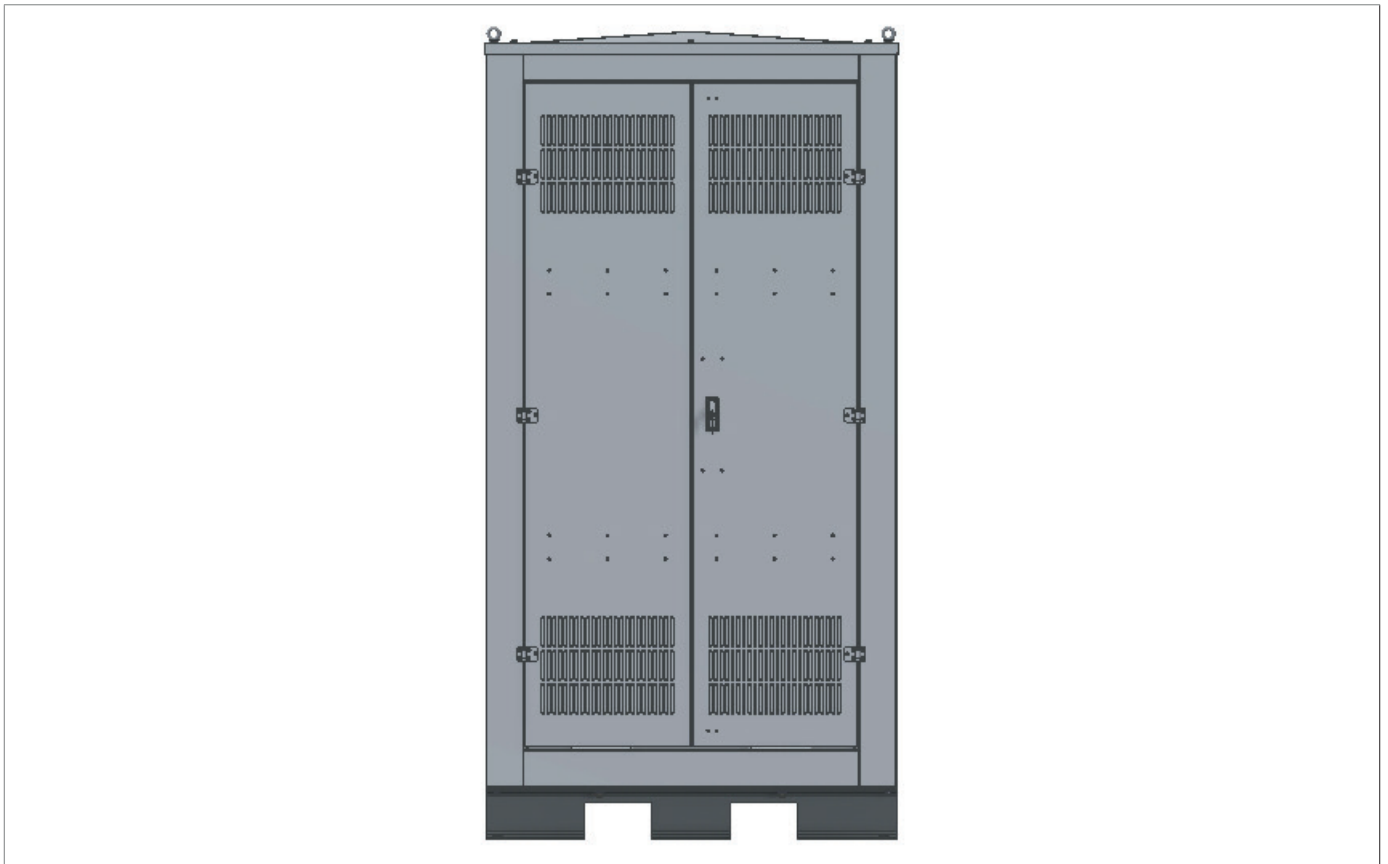

Fig. 4.21. Outdoor frame

4.4 - FIELD DISPLAY

The field display is an optional module integrated into the GEDRA system, designed to display the results of analyses performed by the gas quality analyzer.

This module is equipped with two illuminated buttons that provide information on the operating status of the analyzer. When the red light button is on, it indicates that there is an error in the system, indicating that one or more alarms have been activated. If the green light button is on, it indicates that the field display and the acquisition module are correctly powered.

The module is wall-mounted in a safe area and features a 7-inch touch display, allowing the operator to perform operations directly in local. In addition to local connection, the module also allows remote access via browser.

The field display is equipped with a user interface software that facilitates the interaction between the operator and the GEDRA system (see chapter 5).

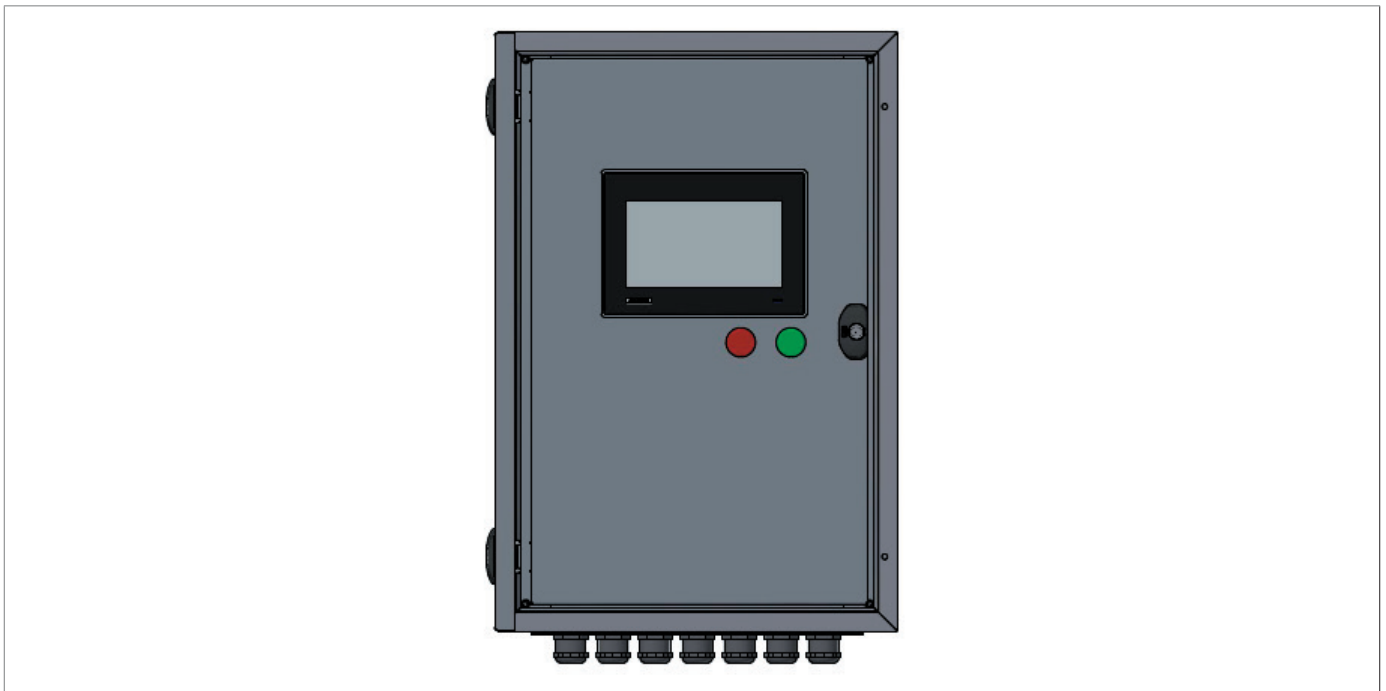

Fig. 4.22. Field display

4.5 - METROLOGICAL AND INSTALLATION SEALS

Considering the operation of the equipment GEDRA, it is essential to maintain the alignment that is set at the factory. For this reason, at the end of the factory calibration and when the Ex-d enclosure is closed, an “anti-tampering” seal will be applied (in green in Fig. 4.23) which highlights the opening of the door (in yellow in Fig. 4.23) of the enclosure and the possible alteration of the optical line.

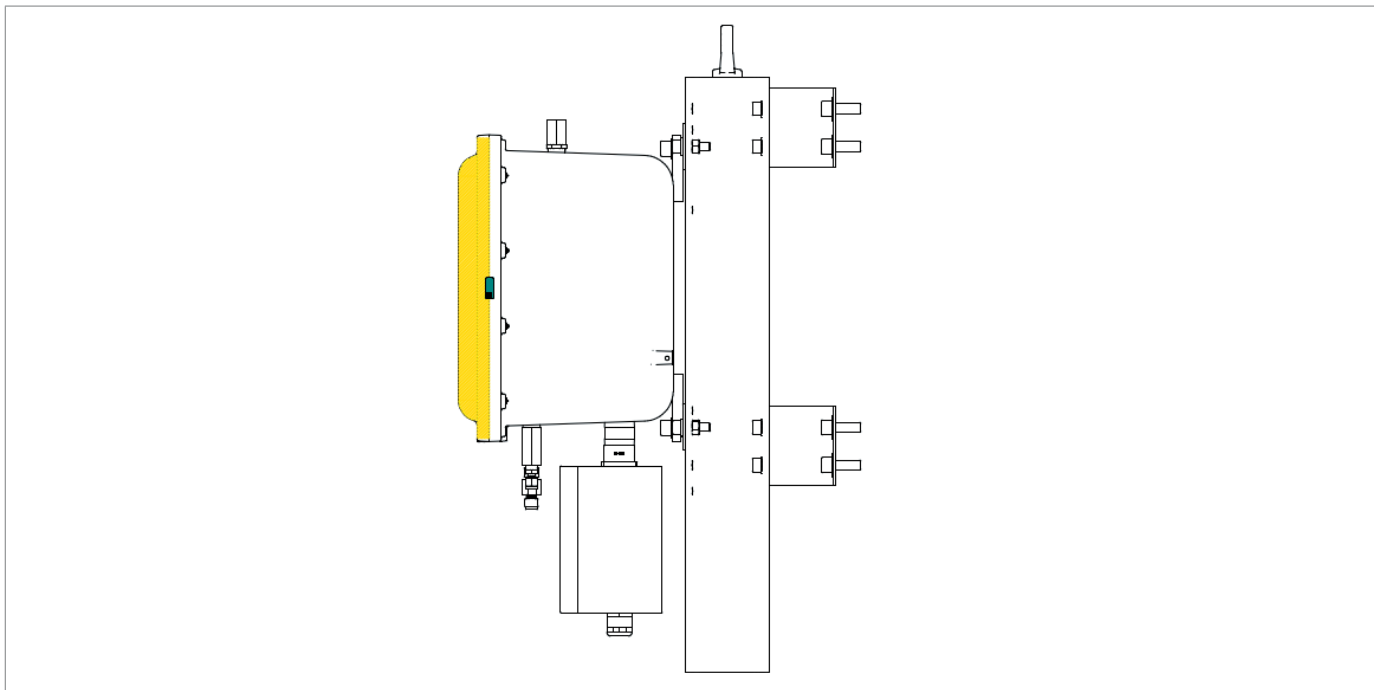

Fig. 4.23. Anti-tampering seal, Ex-d enclosure analysis unit

Depending on the customer's requests, it is possible to apply a second seal that is physically different from the metrological one, which can be applied by the installer at the end of the connection between the operator interface and the Ex-e terminal block installed underneath the analysis unit.

This seal indicates whether there has been tampering with the connection between the analysis unit and the other devices (field display or volume converter).

This seal can be restored in the field by the technician delegated by Pietro Fiorentini. Breaking the seal has no effect on the metrological maintenance of the measurement, so it is not necessary to return the machine to Pietro Fiorentini.

4.6 - ELECTRICAL CHARACTERISTICS OF CABLES

The analysis unit is connected to the Ex-e box via:

- 1 shielded cable, two pairs of 1.5 mm² to power the analysis module
- 1 shielded cable, two pairs of 1mm² to transmit the alarm from the analysis unit to the field display
- 1 shielded cable, six pairs of 0.2 mm² to connect
 - flow computer 1
 - flow computer 2 (if present)
 - remote interface unit (RIU)
 - free for any further user connection
- 2 shielded Ethernet cables available for user connection. An Ethernet cable can be used if router installation is required to ensure remote Wi-Fi connection

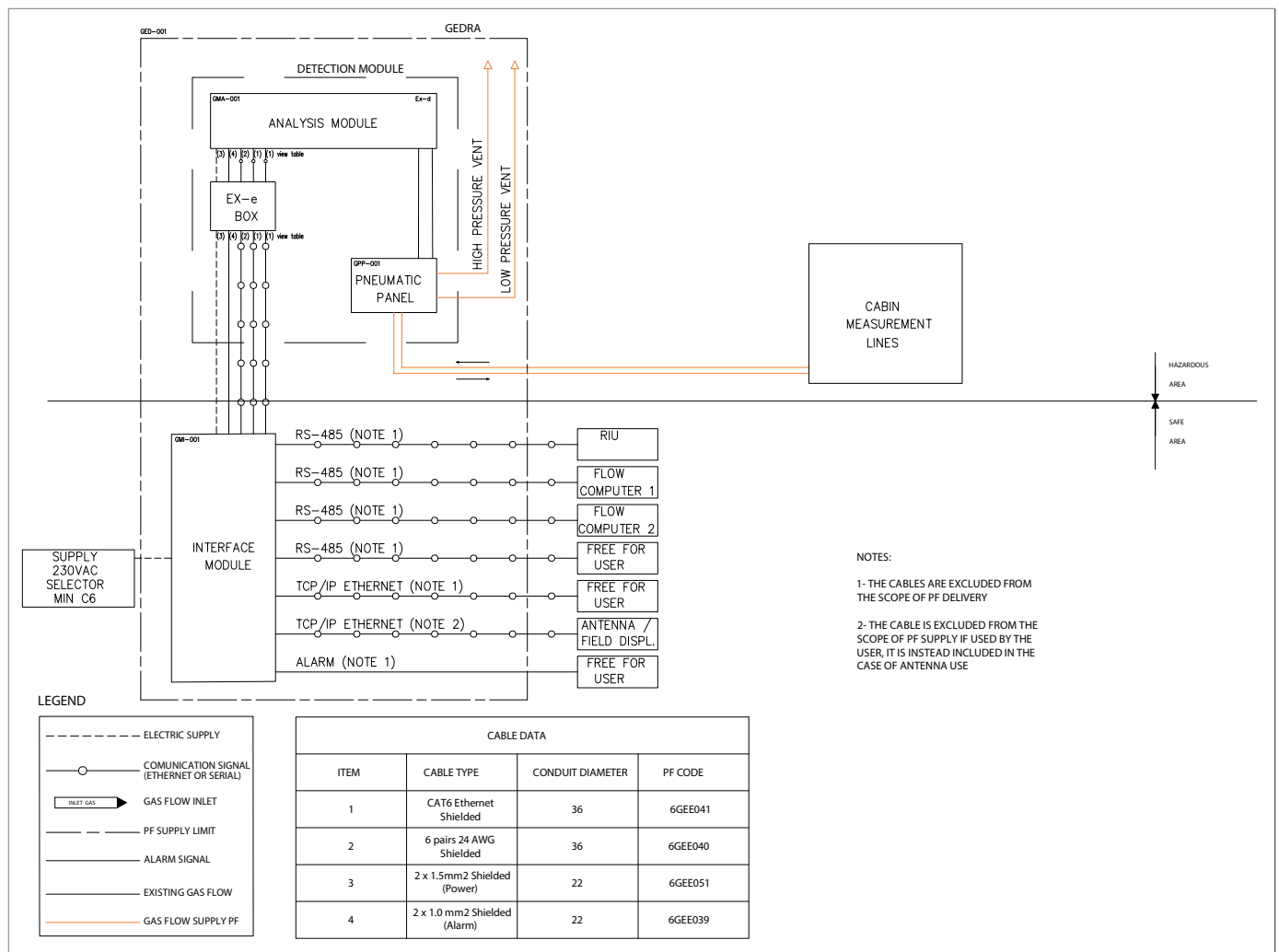

Fig. 4.24. Cable connection

4.7 - METROLOGICAL OPERATING RANGE

GEDRA provides the following results of the analysis of the composition of the gas mixture:

- methane
- carbon dioxide
- ethane
- propane
- isobutane
- n-Butane
- nitrogen
- hydrogen

The data of the chemical-physical characteristics obtained from the composition using three additional parameters, reference temperatures for combustion T1, for the volume T2 and the unit of measurement:

- higher calorific value
- lower calorific value
- upper Wobbe index
- lower Wobbe index
- molar mass
- compressibility factor (Z)
- molar volume
- relative density
- density

GEDRA is suitable for metrological use within the limits indicated in the “TECHNICAL DATA” paragraph (Tab. 4.17).

4.8 - DESIGNED USE

4.8.1 - INTENDED USE

The equipment in question is intended for:

Operation	Permitted	Unpermitted	Work environment
Gas quality analysis	Zone 1 (for IIB+H2 or IIC gases depending on the installed box)	Any other type of gas other than permitted.	Application <ul style="list-style-type: none"> in natural gas transport and distribution networks (equipment confirmed in Part II of the Snam Network Code and paragraph E.2 of UNI 9167) at hydrogen mixing stations

Tab. 4.16.

The equipment referred to was designed to be used exclusively within the limits specified on the identification plate and according to the instructions and limits of use specified in this manual.

Safe work conditions are as follows:

- use within the limits stated on the rating plate and in this manual;
- compliance with the user manual procedures;
- routine maintenance to be carried out when and how recommended;
- special maintenance to be carried out if required;
- do not tamper with and/or bypass the safety devices.

4.8.2 - REASONABLY FORESEEABLE MISUSE

Reasonably foreseeable incorrect use means the use of the equipment in a way not foreseen in the design phase but which can result from readily predictable human behaviour:

- using the equipment in a manner other than that referred to under paragraph “**Intended use**”.
- instinctive reaction of an operator in the event of a malfunction, accident or breakdown while using the equipment;
- behaviour resulting from carelessness;
- behaviour resulting from the use of the equipment by unauthorised and unsuitable people (children, disabled);

Any use of the equipment other than the intended use must be previously approved in writing by PIETRO FIORENTINI S.p.A. If no written approval is provided, use shall be considered “**improper**”.

In the event of improper use, PIETRO FIORENTINI S.p.A. shall not be held liable for any damage caused to people or property, and any type of warranty on the equipment shall be deemed void.

4.9 - TECHNICAL DATA

General features	
Accuracy class (OIML R 140)	Class A (0.5%)
Sampling pressure range	4 ÷ 100 bar
Maximum sampling rate	54 NL/h
Operative temperature range	-20 °C to +50 °C
Power supply	24 VDC
Average-maximum power consumption with display	18W - 25W (max)
Communication	<ul style="list-style-type: none"> • 2x Ethernet • 4x RS485
Lower detection limit	500 ppm
Communication interface	<ul style="list-style-type: none"> • Modbus ASCII according to UNI 11885:2022 • Modbus RTU • Integrated web server • On-site display in safe area available upon request
Installation in hazardous area	<ul style="list-style-type: none"> • Zone 1, II B+H2, T6 Gb • Zone 1, II C, T6 Gb
Higher Calorific Value (HCV)	33.59MJ/Stm ³ - 48.34 MJ/Stm ³
Gas temperature range	-20°C +50°C
Ambient temperature range	-20°C +50°C
Higher calorific value	33.59MJ/Stm ³ - 48.34 MJ/Stm ³
Pressure range	0.5 °C/ 16 barg
Readable compositions	<ul style="list-style-type: none"> • methane • carbon dioxide • ethane • propane • isobutane • n-Butane • nitrogen • hydrogen

Tab. 4.17.

5 - USER INTERFACE

5.1 - GENERAL DESCRIPTION

The user interface is the software that allows interaction between the operator and the system GEDRA. This software runs inside the main board (processing and communication board) and can be viewed via:

- field display: 7-inch touch screen located in a safe area
- laptop: usable both in the field for local operations and remotely to allow the user to monitor and control the performance of the GEDRA at a distance.

The main functions that can be performed through the user interface are:

- view the parameters of the last analysis performed
- view historical data (visible up to 366 days ago)
- view events recorded by GEDRA and by users
- change settings (units of measurement, system time, alarms, etc.)
- perform the metric verification
- firmware update.

Access to the interface is protected by a credential authentication system, where each user must enter a password. The password must meet a minimum security requirement, being at least six characters long. Access to the user interface is structured on four profile levels and specific functions are permitted based on the user's authorization level:

- **user:** this profile has limited access to the system's features, with the only possibility of viewing the latest analysis data and historical data generated by GEDRA. The user does not have the necessary permissions to modify system parameters, nor to create or manage new profiles.
- **maintenance technician:** this profile can modify the instrument's operating parameters and perform periodic maintenance tasks, such as system verification and control. The maintenance technician can create new user profiles, but only those with lower privileges, such as the "user" profile.
- **administrator:** this profile allows you to view and/or modify system parameters, modify metrological files and create new profiles, both at "maintenance technician" and "user" level.
- **proprietary:** this profile has the same functionality as an administrator, plus it can create new administrator profiles. This profile is reserved for the Manufacturer PIETRO FIORENTINI S.p.A.

Summary of the functions accessible based on the permissions assigned to the user:

User Interface Features	User	technician	Administrator	Proprietary
View Information screen	X	X	X	X
View data from the latest analysis performed	X	X	X	X
View analysis history	X	X	X	X
View events	X	X	X	X
Export events	X	X	X	
View system/analysis/alarms/serial/ethernet settings	X	X	X	X
Change system settings: <ul style="list-style-type: none"> • maintenance mode • system language • daylight saving time • system time zone • system date • system time • maintenance time • unit of measurement of temperature • unit of measurement of pressure • operating pressure • presence of solenoid valve • solenoid valve flushing time 		X	X	X
Change analysis settings: <ul style="list-style-type: none"> • HCV unit of measurement • reference temperature • analysis interval • validity of the verification 		X	X	X
Change the alarm limits of different parameters		X	X	X
Change serial settings: <ul style="list-style-type: none"> • door status • transmission speed • flow computer connection protocol 		X	X	X
Change Ethernet settings: <ul style="list-style-type: none"> • address • prefix length • gateway 		X	X	X
Change passwords of users of your level	X	X	X	X
Change passwords of maintenance technicians of your level		X	X	X
Change password of administrator of your level			X	X
Change user, maintenance technician, administrator, proprietary passwords				X
Delete users of your level		X	X	X
Delete maintenance technician of your level			X	X

User Interface Features	User	technician	Administrator	Proprietary
Delete administrator				X
Add new user profiles		X	X	X
Add new maintenance technician profiles			X	X
Add new administrator profiles				X
Carry out periodic verifications		X	X	X
View analysis details (dark in, spectrum, dark out, acquisition images)			X	X
Reset event history			X	X
Update the firmware			X	X

Tab. 5.18.

5.2 - STARTUP PROCEDURE

The startup procedure is the same for all profiles (see paragraph 5.1).

1. Touch the display of the GEDRA
2. Press the unlock black dot to wake up the screen from standby
3. Once the display is reactivated, the system will display the initial system connection screen GEDRA.
4. Please wait for the connection process to complete.

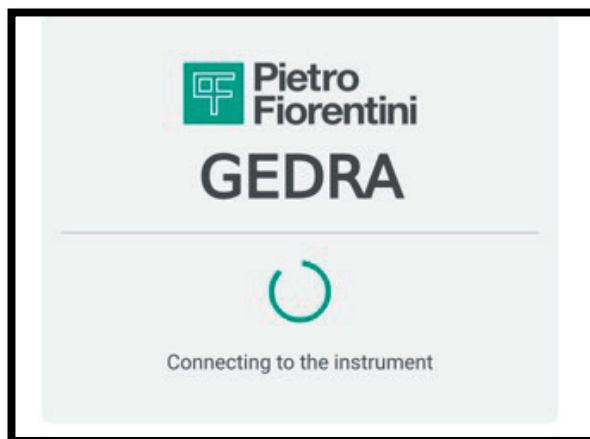

The screen displays the plate information of the installed system.

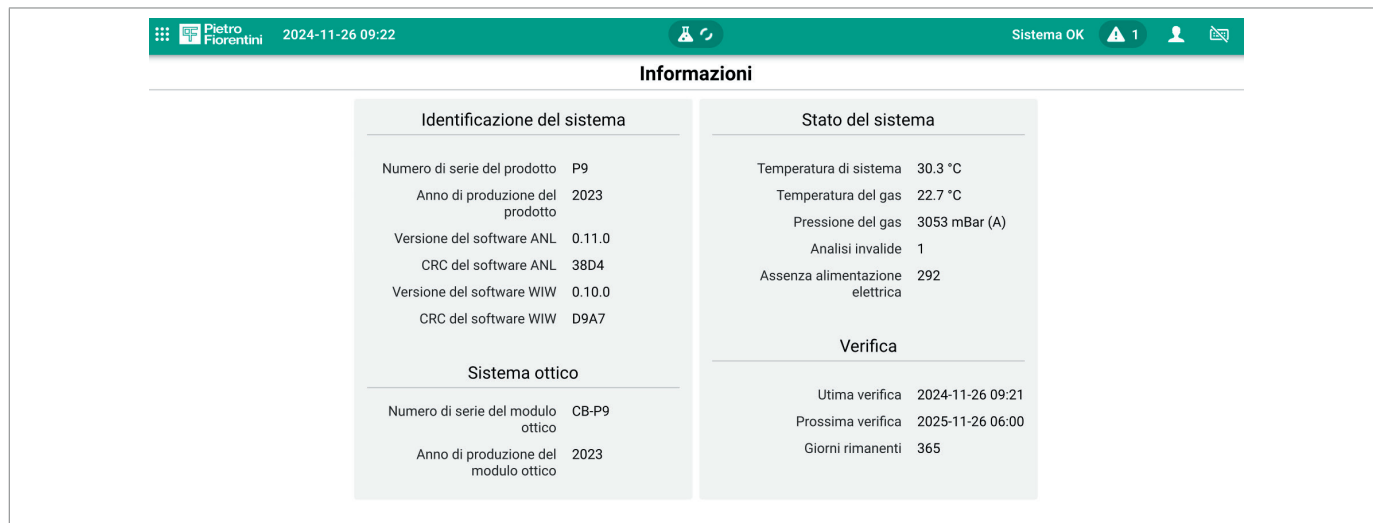

Identificazione del sistema		Stato del sistema	
Numero di serie del prodotto	P9	Temperatura di sistema	30.3 °C
Anno di produzione del prodotto	2023	Temperatura del gas	22.7 °C
Versione del software ANL	0.11.0	Pressione del gas	3053 mBar (A)
CRC del software ANL	38D4	Analisi invalide	1
Versione del software WIW	0.10.0	Assenza alimentazione elettrica	292
CRC del software WIW	D9A7		
Sistema ottico		Verifica	
Numero di serie del modulo ottico	CB-P9	Ultima verifica	2024-11-26 09:21
Anno di produzione del modulo ottico	2023	Prossima verifica	2025-11-26 06:00
		Giorni rimanenti	365

On the “Information” home screen, you can view a series of significant data and details. This screen provides useful information.

SYSTEM IDENTIFICATION

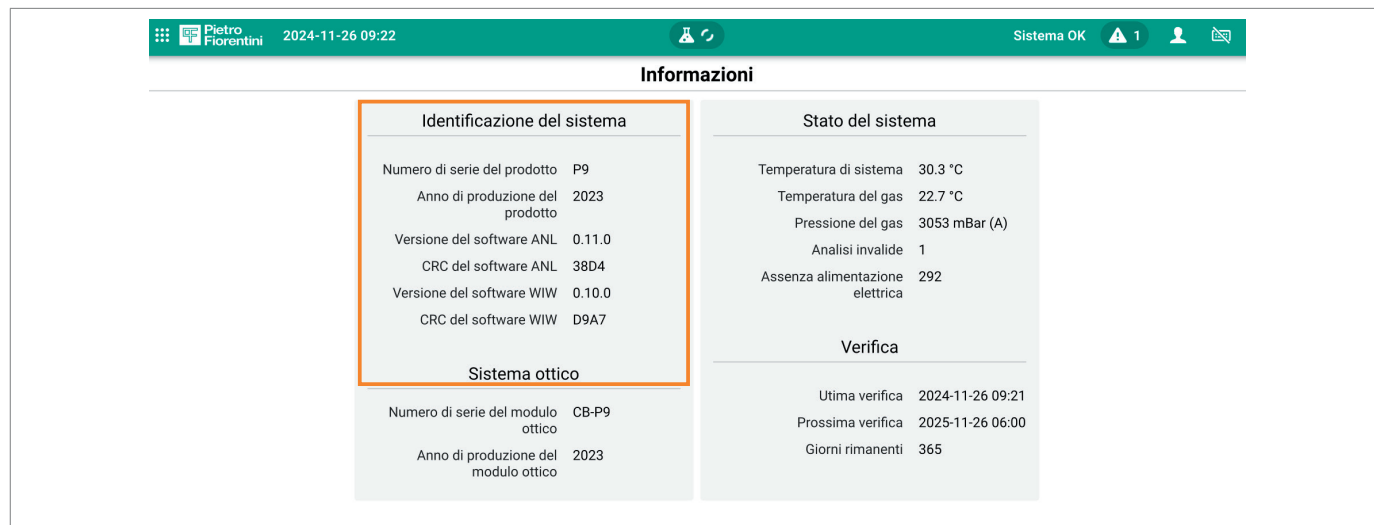

Identificazione del sistema		Stato del sistema	
Numero di serie del prodotto	P9	Temperatura di sistema	30.3 °C
Anno di produzione del prodotto	2023	Temperatura del gas	22.7 °C
Versione del software ANL	0.11.0	Pressione del gas	3053 mBar (A)
CRC del software ANL	38D4	Analisi invalide	1
Versione del software WIW	0.10.0	Assenza alimentazione elettrica	292
CRC del software WIW	D9A7		
Sistema ottico		Verifica	
Numero di serie del modulo ottico	CB-P9	Ultima verifica	2024-11-26 09:21
Anno di produzione del modulo ottico	2023	Prossima verifica	2025-11-26 06:00
		Giorni rimanenti	365

- **Product identification number:** product identification number required by the manufacturer in case of assistance requests
- **Year of production of the product:** identifies the year in which the GEDRA was manufactured, information to be provided to the manufacturer in case of request for assistance
- **ANL software version:** identifies the version of the ANL (analysis) software installed on the system GEDRA. The ANL software manages the instrument's function (analysis) by controlling the hardware, implements Modbus and Web-Socket servers for external communications. This information is essential for technical support
- **ANL software CRC:** ANL software CRC (Cyclic Redundancy Check) is a numeric value generated by an algorithm that verifies the integrity of the ANL software data. This is necessary to determine if the software file has been altered. In case of service, the CRC value can be compared with the expected one to identify any errors or malfunctions
- **WIW software version:** refers to the WIW (Web Interface Window) software version. WIW software is a Web Assembly code that manages the user interface (everything that can be viewed on a browser or display)
- **WIW software CRC:** CRC stands for Cyclic Redundancy Check in WIW software, it is an integrity check similar to that of ANL software, applied specifically to web software files. This CRC value verifies that files have not been damaged or altered during transfer or installation. During the service process, the CRC value can be used to diagnose integrity issues and ensure that the installed version is working properly

SYSTEM STATUS

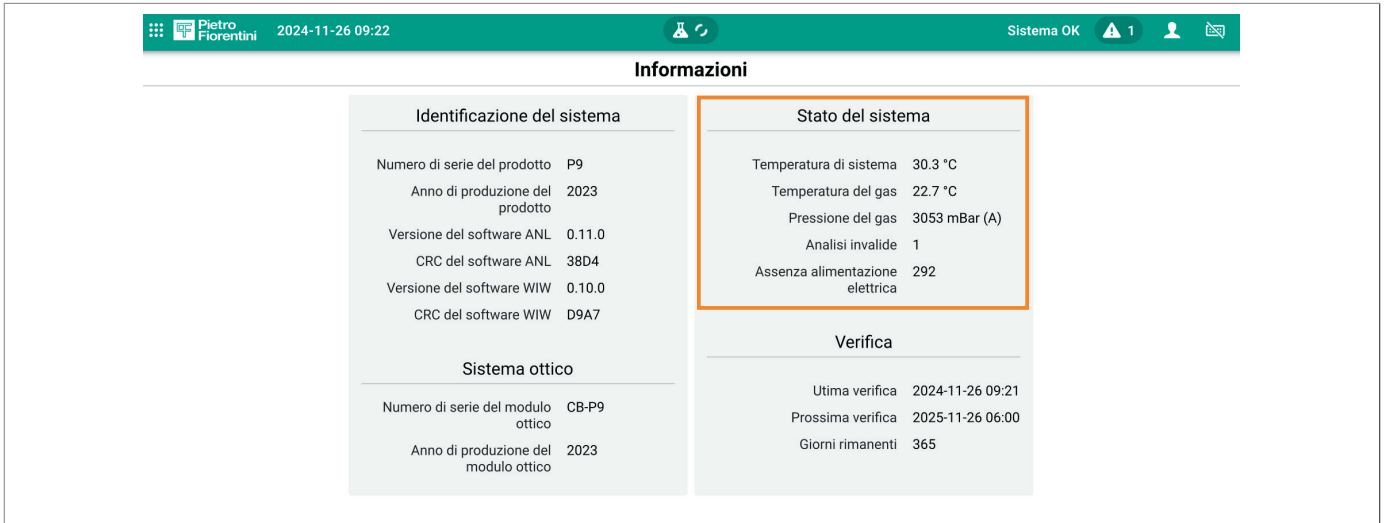

Identificazione del sistema	
Numero di serie del prodotto	P9
Anno di produzione del prodotto	2023
Versione del software ANL	0.11.0
CRC del software ANL	38D4
Versione del software WIW	0.10.0
CRC del software WIW	D9A7

Stato del sistema	
Temperatura di sistema	30.3 °C
Temperatura del gas	22.7 °C
Pressione del gas	3053 mBar (A)
Analisi invalide	1
Assenza alimentazione elettrica	292

Sistema ottico	
Numero di serie del modulo ottico	CB-P9
Anno di produzione del modulo ottico	2023

Verifica	
Ultima verifica	2024-11-26 09:21
Prossima verifica	2025-11-26 06:00
Giorni rimanenti	365

- **System temperature:** indicates the internal temperature of the Ex-d enclosure of the analysis cell, measured in real time by a temperature sensor located in the identified IC9 board
- **Gas temperature:** indicates the temperature of the gas inside the analysis cell GEDRA, measured in real time by a temperature sensor located in the analysis cell
- **Gas pressure:** indicates the gas pressure inside the analysis cell GEDRA, measured in real time by a temperature sensor located on the board identified as IC9
- **Invalid analyses:** represents the number of analyses that did not successfully pass the periodic verification. This constitutes a critical error from a metrological point of view, which leads to the immediate interruption of the analysis. For more information, see Periodic verification section 5.4.3.
- **No power supply:** indicates the number of times the power supply to the GEDRA was down.

OPTICAL SYSTEM

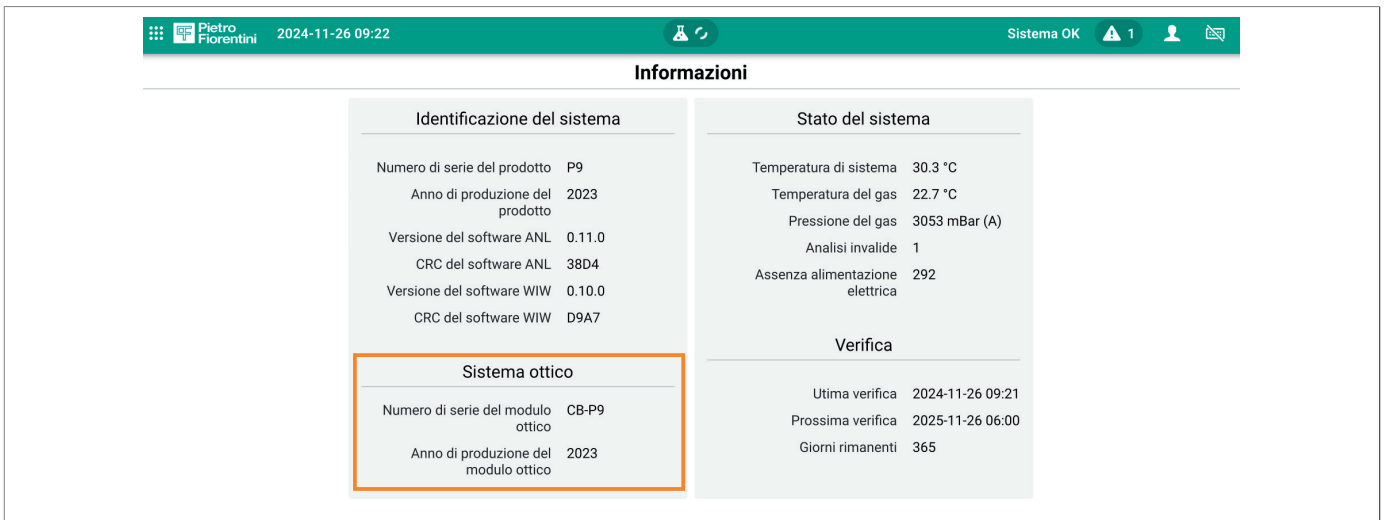

Identificazione del sistema	
Numero di serie del prodotto	P9
Anno di produzione del prodotto	2023
Versione del software ANL	0.11.0
CRC del software ANL	38D4
Versione del software WIW	0.10.0
CRC del software WIW	D9A7

Stato del sistema	
Temperatura di sistema	30.3 °C
Temperatura del gas	22.7 °C
Pressione del gas	3053 mBar (A)
Analisi invalide	1
Assenza alimentazione elettrica	292

Sistema ottico	
Numero di serie del modulo ottico	CB-P9
Anno di produzione del modulo ottico	2023

Verifica	
Ultima verifica	2024-11-26 09:21
Prossima verifica	2025-11-26 06:00
Giorni rimanenti	365

- **Optical module identification number:** identification number of the optical module used for the traceability of this component, useful for maintenance or technical assistance requests
- **Optical module year of production:** identifies the year in which the optical module was manufactured, information necessary to define the component's life cycle and for any updates or maintenance interventions.

CHECK

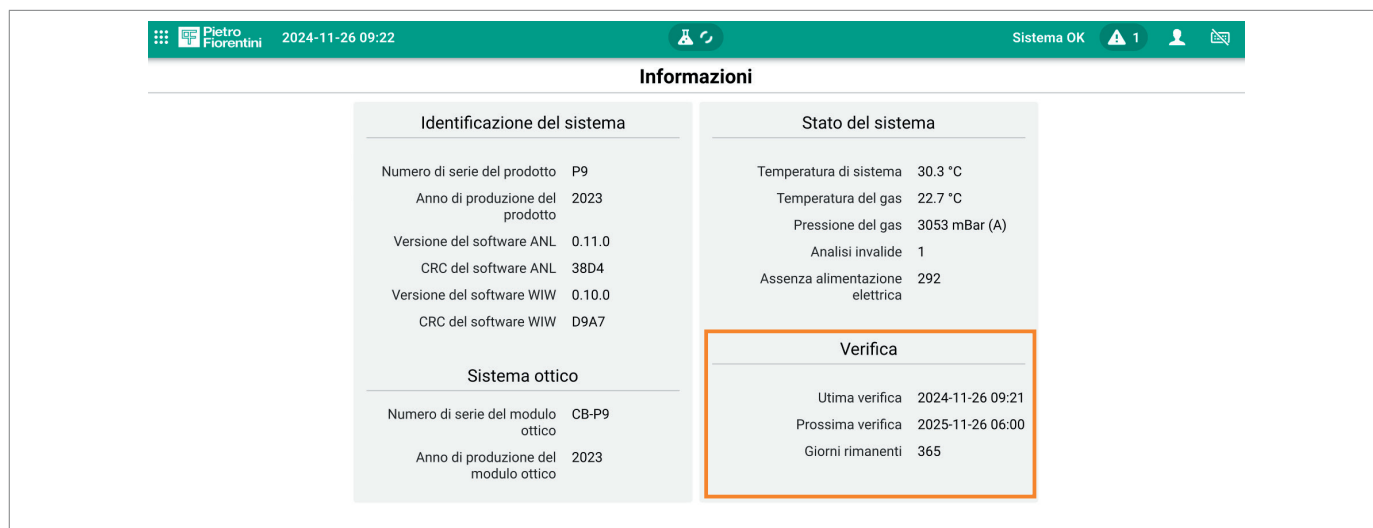

The screenshot shows the 'Informazioni' (Information) screen. At the top, a green status bar displays 'Sistema OK' with a warning icon and the number '1'. The main content is divided into two columns: 'Identificazione del sistema' and 'Stato del sistema'. The 'Verifica' (Verification) section is highlighted with an orange border.

Identificazione del sistema		Stato del sistema	
Numero di serie del prodotto	P9	Temperatura di sistema	30.3 °C
Anno di produzione del prodotto	2023	Temperatura del gas	22.7 °C
Versione del software ANL	0.11.0	Pressione del gas	3053 mBar (A)
CRC del software ANL	38D4	Analisi invalide	1
Versione del software WIW	0.10.0	Assenza alimentazione elettrica	292
CRC del software WIW	D9A7		
Sistema ottico		Verifica	
Numero di serie del modulo ottico	CB-P9	Ultima verifica	2024-11-26 09:21
Anno di produzione del modulo ottico	2023	Prossima verifica	2025-11-26 06:00
		Giorni rimanenti	365

- **Last check:** indicates the date and time of the last metrological check carried out by a metric operator in the system
- **Next check:** indicates the date and time scheduled for the next metrological verification to be carried out in the system
- **Remaining days:** indicates the number of days remaining until the next scheduled check. The validity of the calibration refers to the duration indicated on the OIML R140 metrological certificate of the equipment.

The initial power-on screen displays a bar representing the operating status (regular operation, maintenance mode, anomalies) of the system.

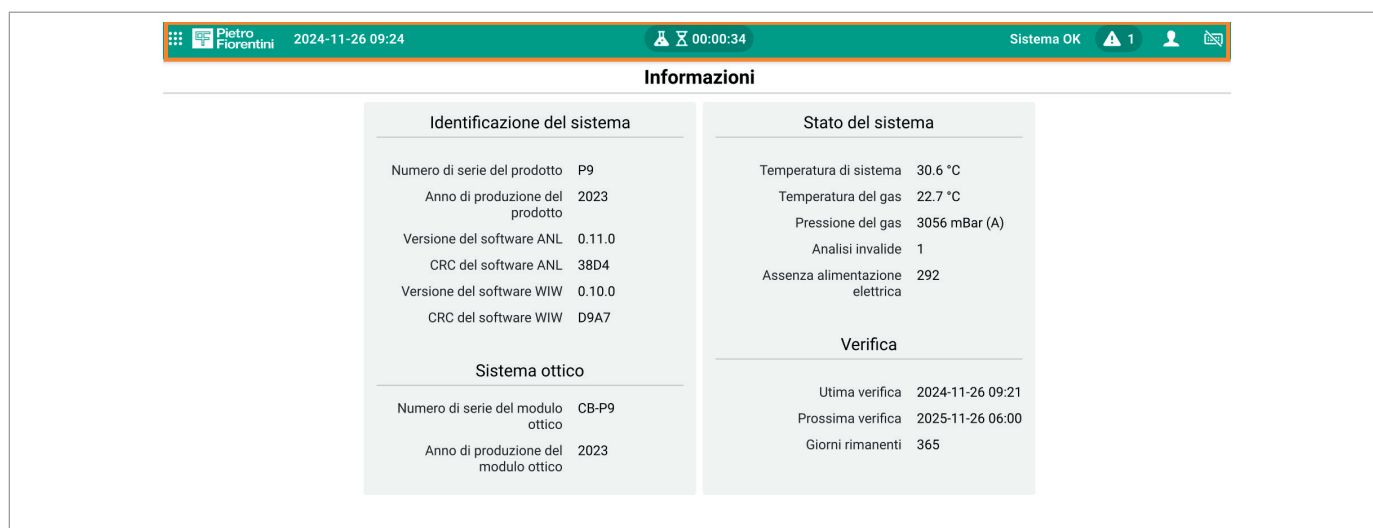

The screenshot shows the 'Informazioni' (Information) screen with a yellow status bar. The main content is divided into two columns: 'Identificazione del sistema' and 'Stato del sistema'. The 'Verifica' (Verification) section is highlighted with an orange border.

Identificazione del sistema		Stato del sistema	
Numero di serie del prodotto	P9	Temperatura di sistema	30.6 °C
Anno di produzione del prodotto	2023	Temperatura del gas	22.7 °C
Versione del software ANL	0.11.0	Pressione del gas	3056 mBar (A)
CRC del software ANL	38D4	Analisi invalide	1
Versione del software WIW	0.10.0	Assenza alimentazione elettrica	292
CRC del software WIW	D9A7		
Sistema ottico		Verifica	
Numero di serie del modulo ottico	CB-P9	Ultima verifica	2024-11-26 09:21
Anno di produzione del modulo ottico	2023	Prossima verifica	2025-11-26 06:00
		Giorni rimanenti	365

The colour of the bar varies to provide an immediate visual indication of the operating conditions of the GEDRA, allowing operators to quickly identify any problems or confirm that the device is functioning correctly.

- Green: indicates normal operation. Even in the presence of system alarms, the correct functioning of the instrument is guaranteed. Alarms are anomalies that do not constitute metrological problems in the measurement. These anomalies should not be present, so it is necessary to plan a verification and/or resolution intervention.
- Yellow: indicates that the instrument is in maintenance mode. In this mode, automatic gas analyses are temporarily interrupted, keeping the results of the last analysis performed valid. Maintenance mode is used during metrological verification operations (as described in the "Verification" paragraph).
- Red: indicates the presence of an error that compromises the normal functioning of the GEDRA, interrupting the gas analysis and keeping the results of the last analysis carried out valid.

The bar colours refer to the last analysis performed. For further details, please see the "Events" section.

The bar provides information on the time remaining before the next analysis.

5.3 - LOGIN PROCEDURE

The procedure for accessing the user interface is the same for all profiles (see paragraph 5.1).

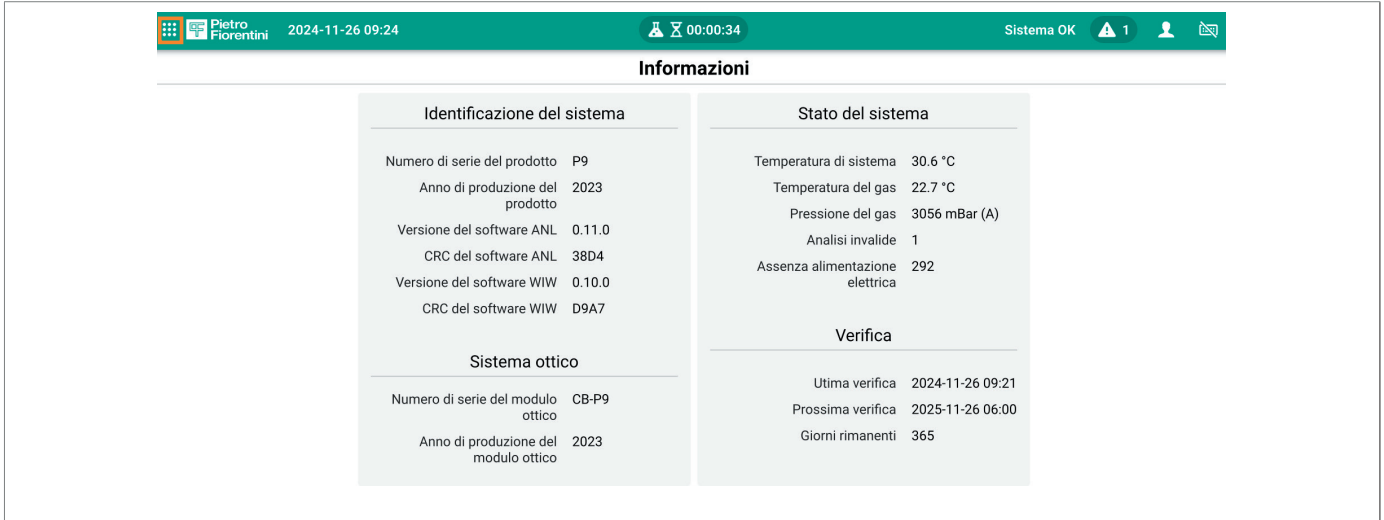

Identificazione del sistema		Stato del sistema	
Numero di serie del prodotto	P9	Temperatura di sistema	30.6 °C
Anno di produzione del prodotto	2023	Temperatura del gas	22.7 °C
Versione del software ANL	0.11.0	Pressione del gas	3056 mBar (A)
CRC del software ANL	38D4	Analisi invalide	1
Versione del software WIW	0.10.0	Assenza alimentazione elettrica	292
CRC del software WIW	D9A7		
Sistema ottico		Verifica	
Numero di serie del modulo ottico	CB-P9	Ultima verifica	2024-11-26 09:21
Anno di produzione del modulo ottico	2023	Prossima verifica	2025-11-26 06:00
		Giorni rimanenti	365

1. Access the “Menu” section by clicking the first icon on the left, next to the Pietro Fiorentini logo.
2. Select “Login” from the drop-down menu to continue with the login process.

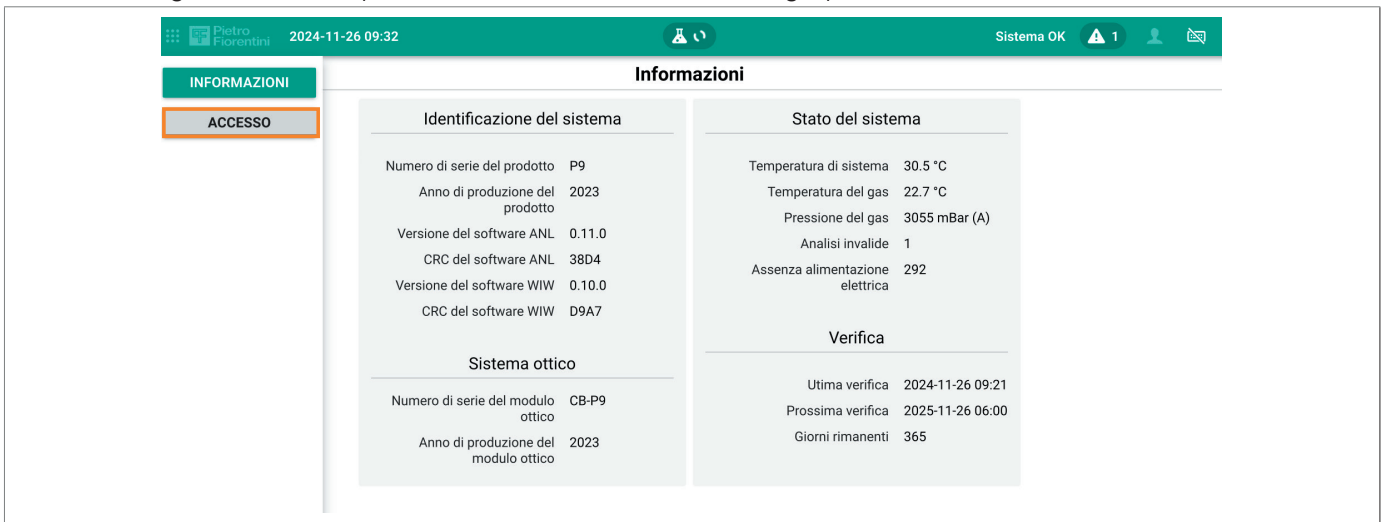

3. Enter your username and password on the “Login” screen.
4. Confirm your action by clicking the “Login” button.

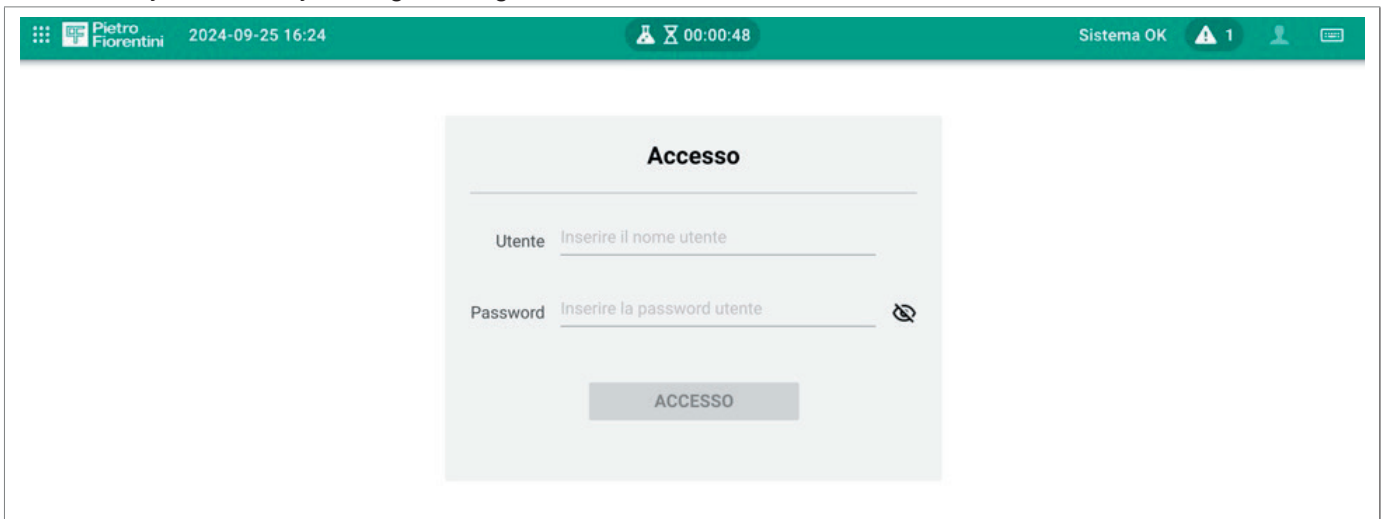

5. You can use either the field display keyboard or your computer keyboard if you are connecting from a browser.

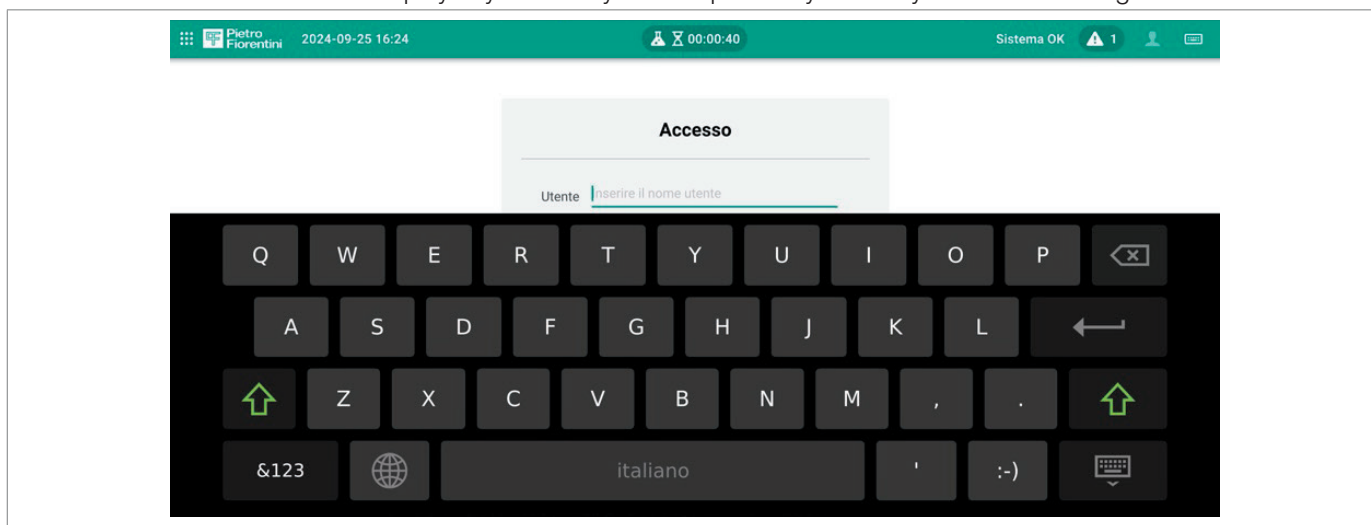

6. Click the first icon from the right to activate the keyboard. Click it again to disable it, making sure the icon is crossed out.

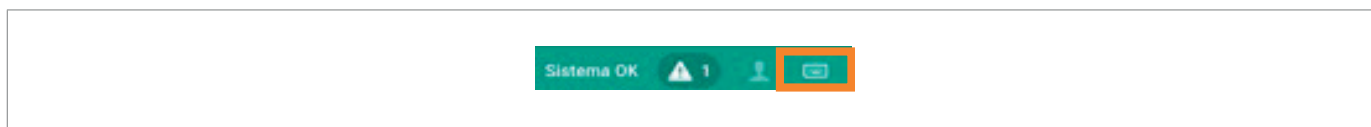

If the username or password is incorrect, a red message will appear on the screen. In case of failure to connect to the GEDRA, a system error screen will appear on the display. To fix it:

1. Check the Ethernet cable connection to the field display
2. Check that the connectors are inserted correctly into their respective ports.

If the problem still occurs, please write to service@fiorentini.com to receive technical support.

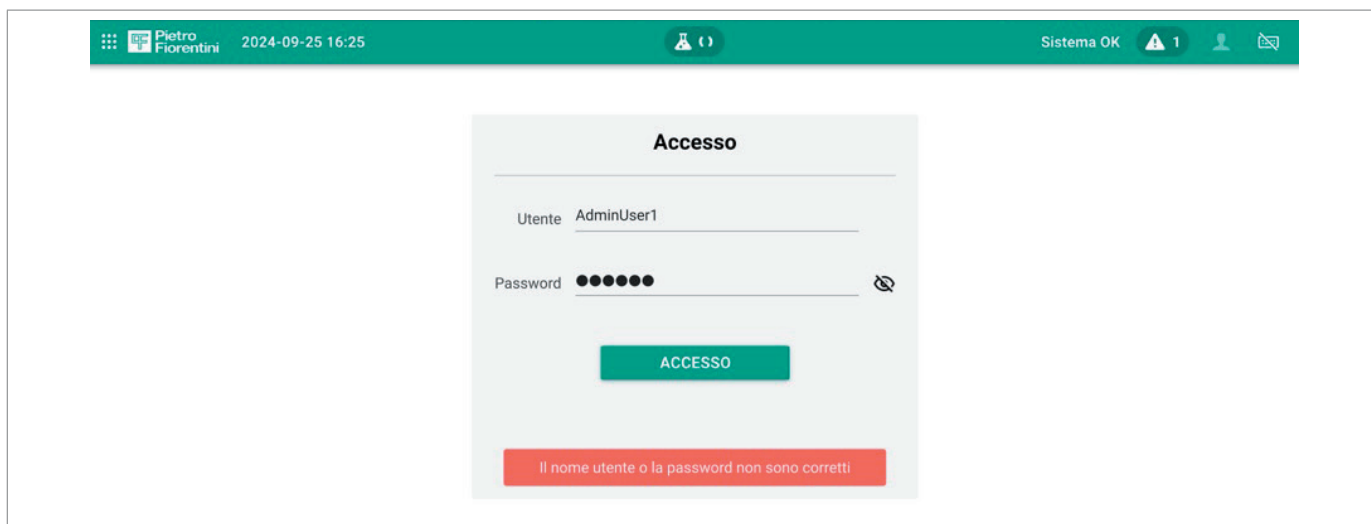



5.4 - OPERATIONS PERMITTED BY THE “USER” PROFILE

The activities that the “user” profile can do are:

- view the latest analysis information
- view historical analysis data
- monitor events
- view system settings
- view system details
- change profile password.

You cannot make changes to system parameters, create or manage new profiles.

After logging in (paragraph 5.3), the user can view the information on the main screen.

To change your account password or log out, click the icon in the top right.

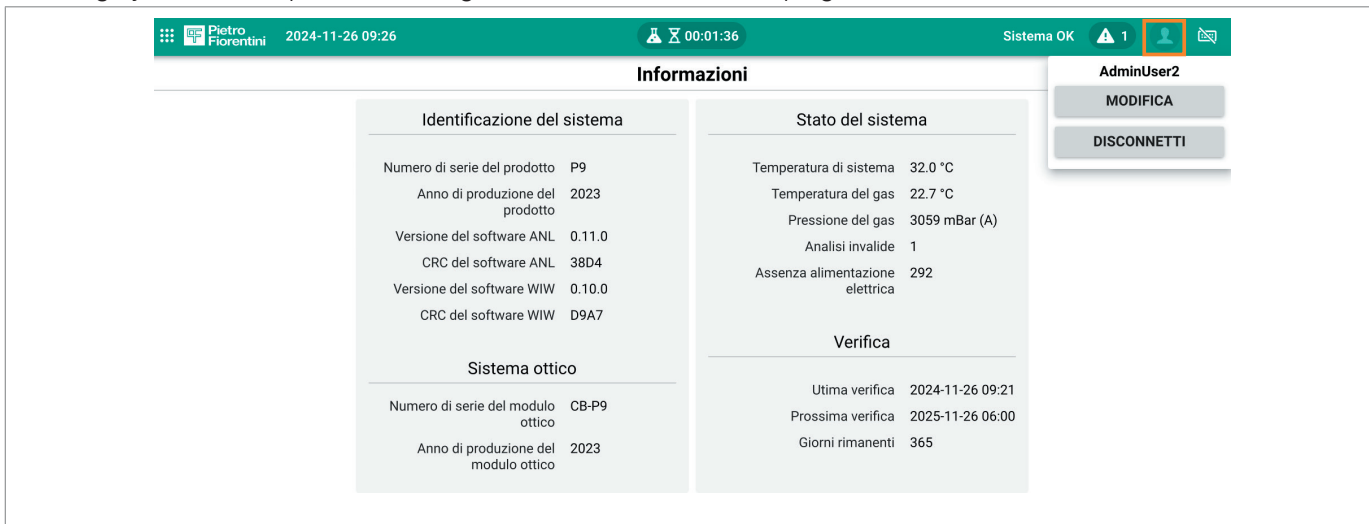

The screenshot shows the main interface of the GEDRA system. At the top, there is a green header bar with the Pietro Fiorentini logo, the date and time '2024-11-26 09:26', a clock icon showing '00:01:36', and the status 'Sistema OK' with a warning icon and the number '1'. On the right side of the header, there is a user profile icon for 'AdminUser2' and a notification icon.

The main content area is titled 'Informazioni' and is divided into three sections:

- Identificazione del sistema**

Numero di serie del prodotto	P9
Anno di produzione del prodotto	2023
Versione del software ANL	0.11.0
CRC del software ANL	38D4
Versione del software WIW	0.10.0
CRC del software WIW	D9A7
- Stato del sistema**

Temperatura di sistema	32.0 °C
Temperatura del gas	22.7 °C
Pressione del gas	3059 mBar (A)
Analisi invalide	1
Assenza alimentazione elettrica	292
- Verifica**

Ultima verifica	2024-11-26 09:21
Prossima verifica	2025-11-26 06:00
Giorni rimanenti	365

Below the 'Stato del sistema' section, there is a 'Sistema ottico' section:

Numero di serie del modulo ottico	CB-P9
Anno di produzione del modulo ottico	2023

On the right side, there is a user profile dropdown menu for 'AdminUser2' with two buttons: 'MODIFICA' and 'DISCONNETTI'.

5.4.1 - CHANGE THE PASSWORD

1. Click on the icon at the top right
2. Click “Edit” from the drop-down menu

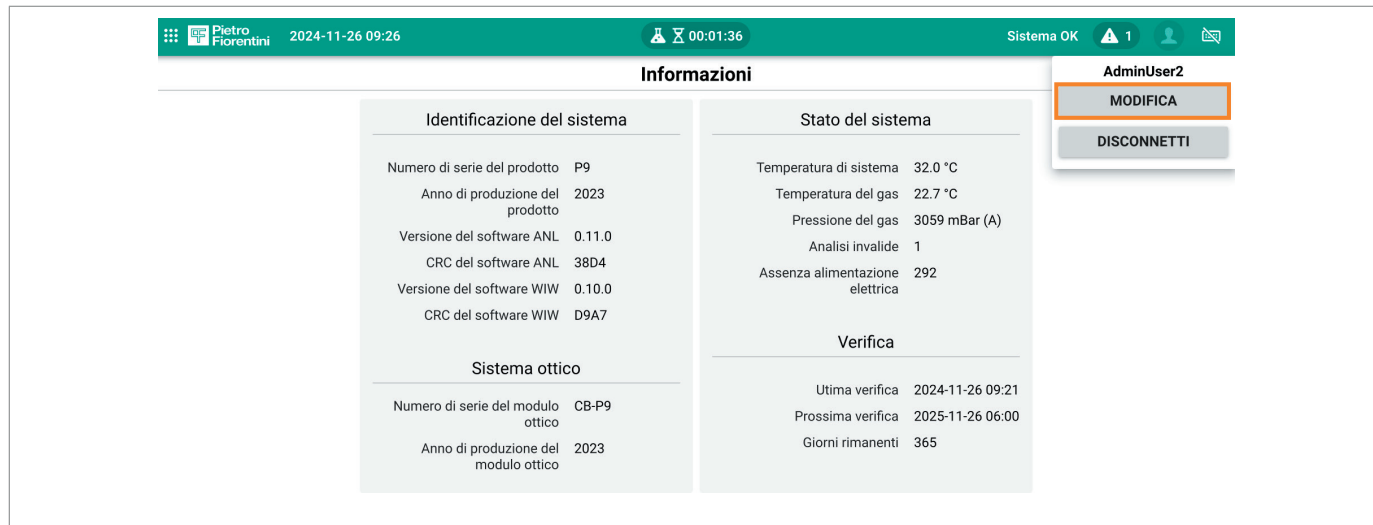

3. Create the new password and enter it again to confirm the new password
4. Click the “Save” button to save your changes, or click the “Cancel” button to cancel your changes.

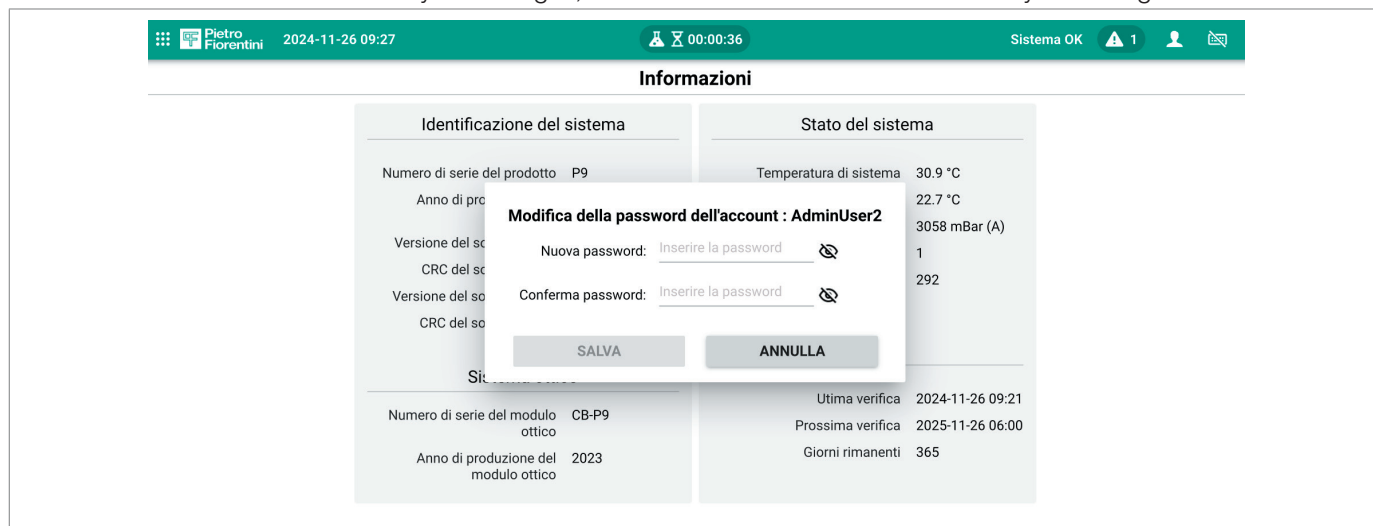

5.4.2 - VIEW THE ANALYSIS

This screen shows the following data:

- detected by the last analysis carried out, indicating the date and time on the left side of the display
- relating to the temperature and pressure of the gas, are located on the right side of the display.

1. Access the “Menu” section by clicking the first icon on the left, next to the Pietro Fiorentini logo
2. Click on the “Analysis” button from the drop-down menu.

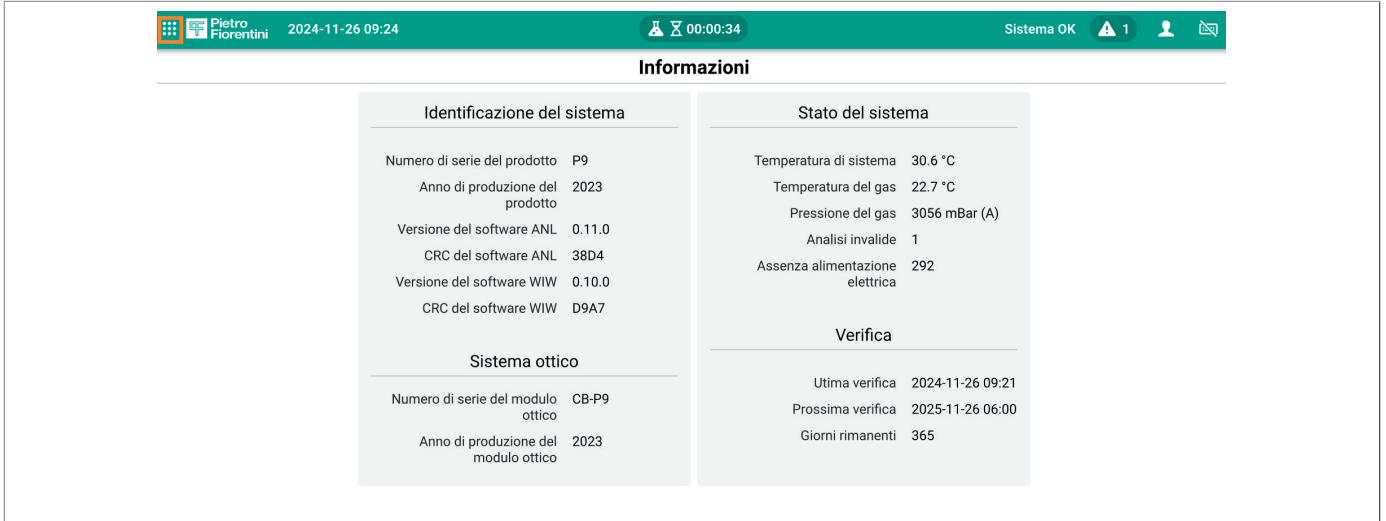

Informazioni

Identificazione del sistema		Stato del sistema	
Numero di serie del prodotto	P9	Temperatura di sistema	30.6 °C
Anno di produzione del prodotto	2023	Temperatura del gas	22.7 °C
Versione del software ANL	0.11.0	Pressione del gas	3056 mBar (A)
CRC del software ANL	38D4	Analisi invalide	1
Versione del software WIW	0.10.0	Assenza alimentazione elettrica	292
CRC del software WIW	D9A7		
Sistema ottico		Verifica	
Numero di serie del modulo ottico	CB-P9	Ultima verifica	2024-11-26 09:21
Anno di produzione del modulo ottico	2023	Prossima verifica	2025-11-26 06:00
		Giorni rimanenti	365

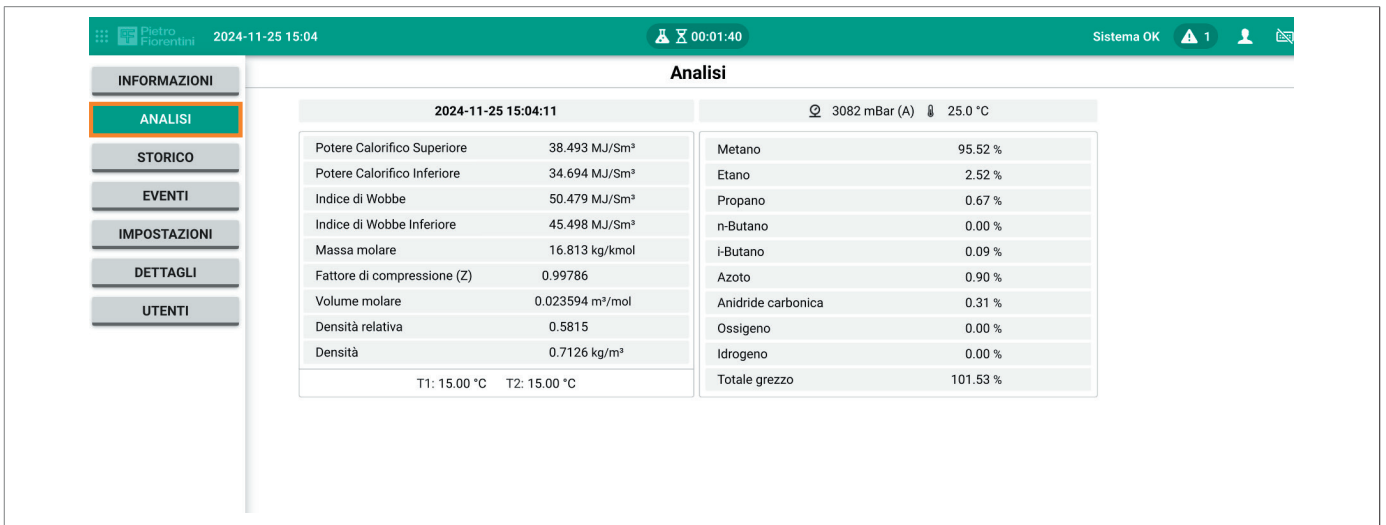

Analisi

2024-11-25 15:04:11 3082 mBar (A) 25.0 °C

Potere Calorifico Superiore	38.493 MJ/Sm ³	Metano	95.52 %
Potere Calorifico Inferiore	34.694 MJ/Sm ³	Etano	2.52 %
Indice di Wobbe	50.479 MJ/Sm ³	Propano	0.67 %
Indice di Wobbe Inferiore	45.498 MJ/Sm ³	n-Butano	0.00 %
Massa molare	16.813 kg/kmol	i-Butano	0.09 %
Fattore di compressione (Z)	0.99786	Azoto	0.90 %
Volume molare	0.023594 m ³ /mol	Anidride carbonica	0.31 %
Densità relativa	0.5815	Ossigeno	0.00 %
Densità	0.7126 kg/m ³	Idrogeno	0.00 %
T1: 15.00 °C T2: 15.00 °C		Totale grezzo	101.53 %

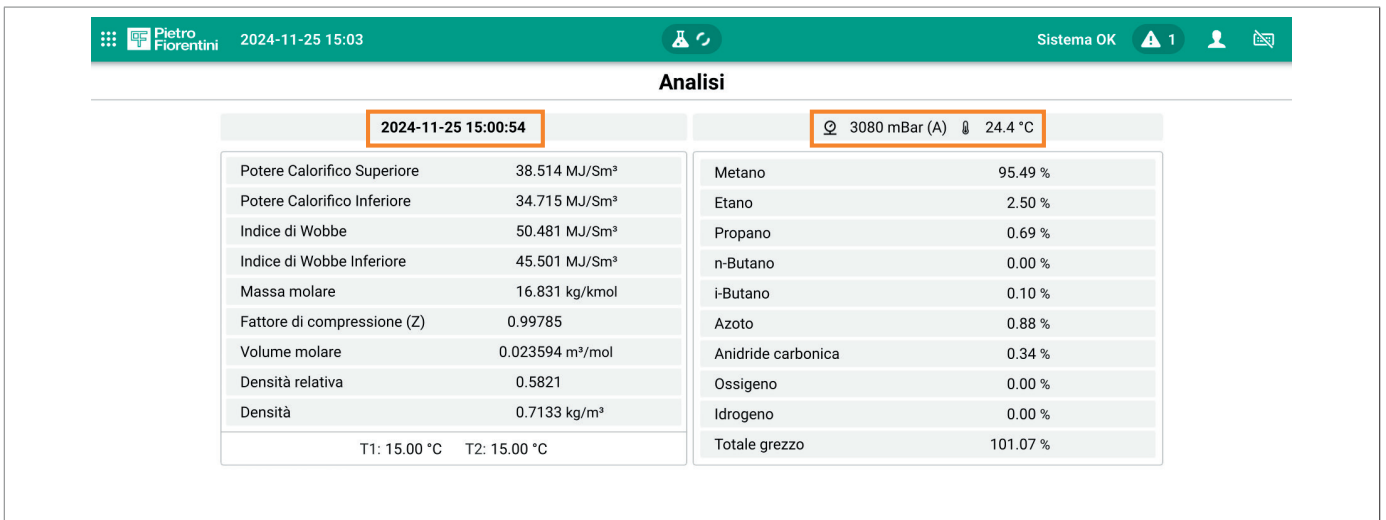

Analisi

2024-11-25 15:00:54 3080 mBar (A) 24.4 °C

Potere Calorifico Superiore	38.514 MJ/Sm ³	Metano	95.49 %
Potere Calorifico Inferiore	34.715 MJ/Sm ³	Etano	2.50 %
Indice di Wobbe	50.481 MJ/Sm ³	Propano	0.69 %
Indice di Wobbe Inferiore	45.501 MJ/Sm ³	n-Butano	0.00 %
Massa molare	16.831 kg/kmol	i-Butano	0.10 %
Fattore di compressione (Z)	0.99785	Azoto	0.88 %
Volume molare	0.023594 m ³ /mol	Anidride carbonica	0.34 %
Densità relativa	0.5821	Ossigeno	0.00 %
Densità	0.7133 kg/m ³	Idrogeno	0.00 %
T1: 15.00 °C T2: 15.00 °C		Totale grezzo	101.07 %

5.4.3 - READING THE ANALYSIS HISTORY

1. Access the “Menu” section by clicking the first icon on the left, next to the Pietro Fiorentini logo
2. Click on the “History” button from the drop-down menu

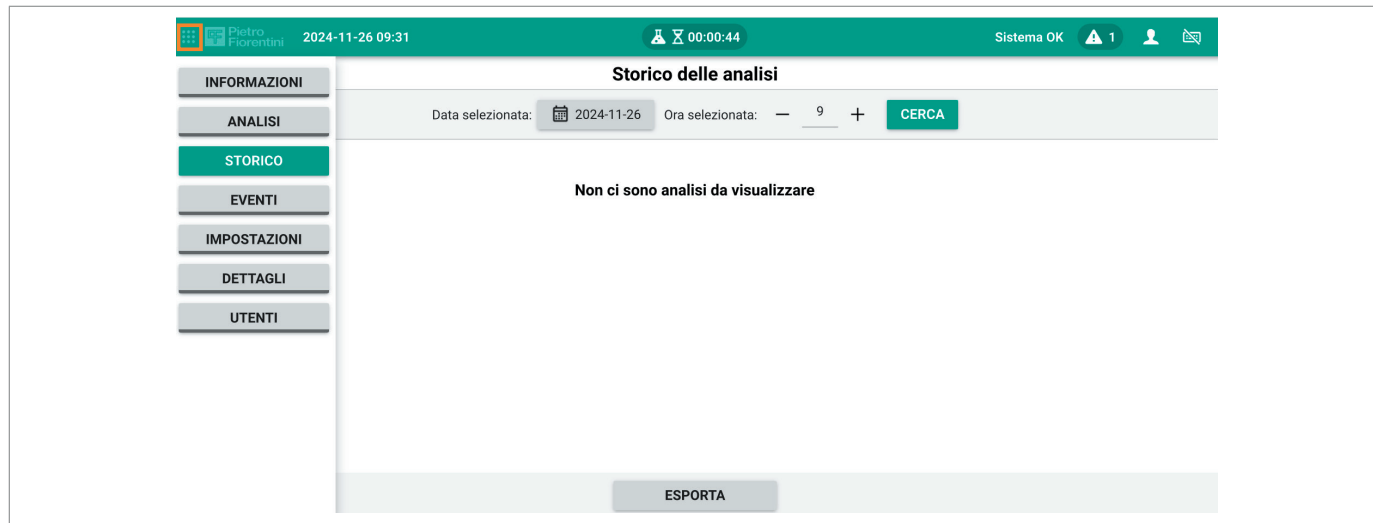

3. Choose the selected date and time from the drop-down menu
 - Choose the desired date from the calendar that will appear on the screen
 - Select the desired time from the drop-down menu among those in the analysis history

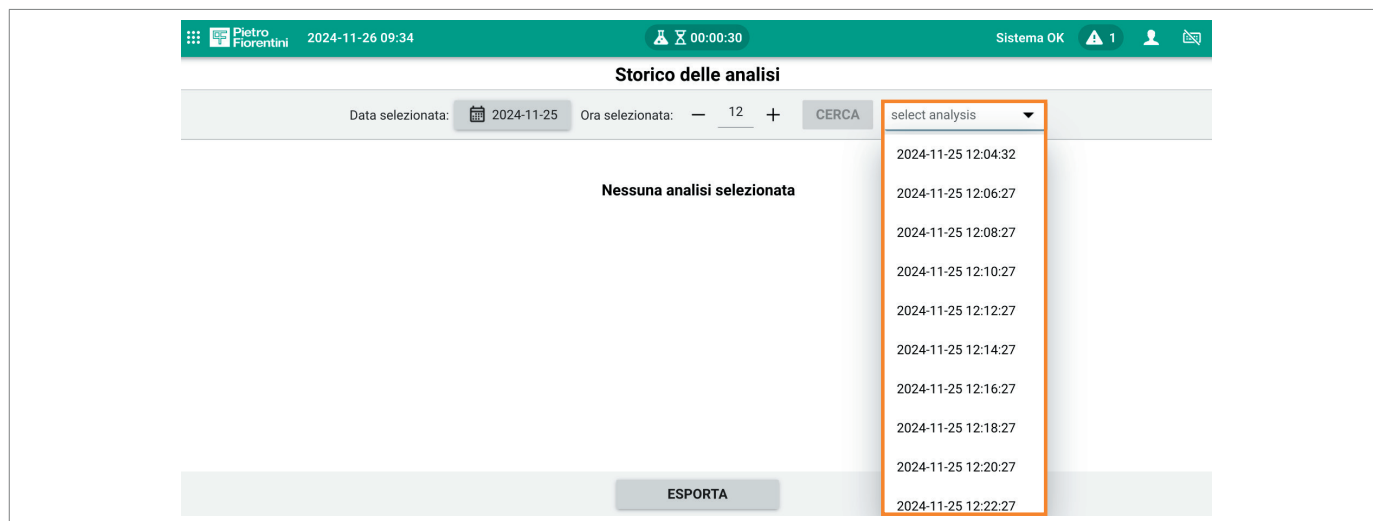
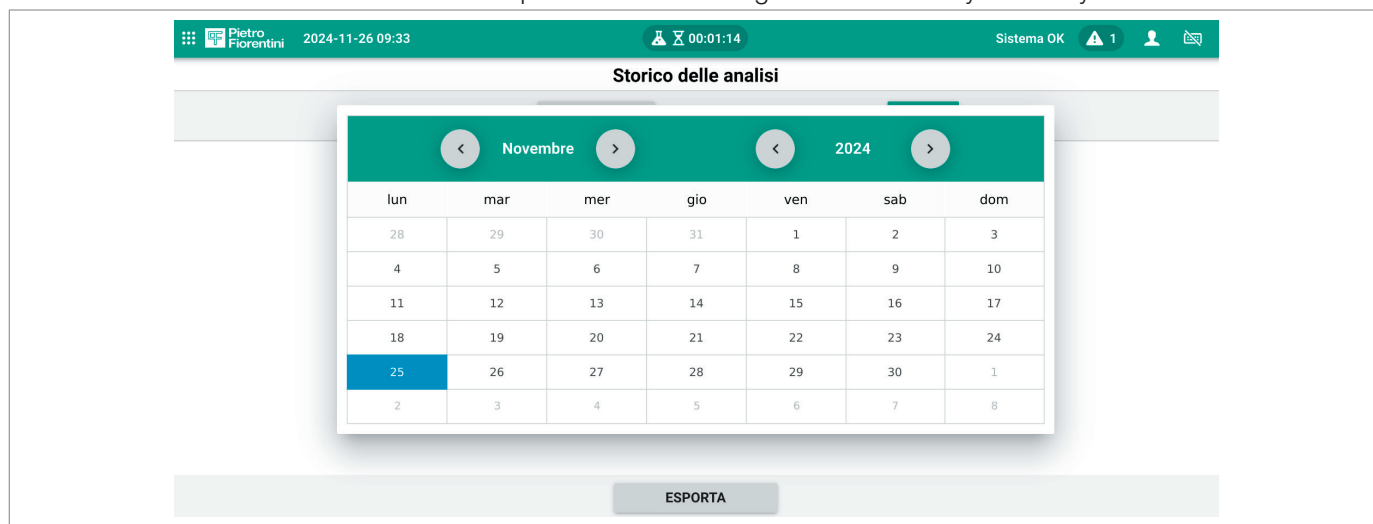

4. Confirm this action by clicking the “Search” button



The screenshot shows the 'Storico delle analisi' (Analysis History) interface. At the top, there is a header with the company logo, date (2024-11-26 09:33), and system status (Sistema OK). Below the header, the title 'Storico delle analisi' is centered. Underneath, there is a search bar with 'Data selezionata: 2024-11-25' and 'Ora selezionata: - 9 +'. A 'CERCA' button is highlighted with an orange box. Below the search bar, the text 'Non ci sono analisi da visualizzare' (No analyses to display) is shown. At the bottom, there is an 'ESPORTA' button.

5. Click on the “Export” button to obtain an Excel file with the analysis data for the selected period



The screenshot shows the 'Storico delle analisi' interface with a modal dialog open. The dialog has a title bar with '2024-11-25 12:08:27' and '3076 mBar (A) 23.6 °C'. It contains a table of analysis parameters and their values. A modal dialog is open over the table, allowing the user to select a time range. The dialog has 'Da' (From) and 'A' (To) fields, both with date and time pickers. The 'Da' field is set to '2024-11-25 12:00:00' and the 'A' field is set to '2024-11-25 13:00:00'. Below the time pickers, there are 'ESPORTA' and 'ANNULLA' buttons. The 'ESPORTA' button is highlighted with an orange box. Below the modal dialog, there is an 'ESPORTA' button.

2024-11-25 12:08:27		3076 mBar (A) 23.6 °C	
Potere Calorifico Superiore			95.48 %
Potere Calorifico Inferiore			2.52 %
Indice di Wobbe			0.67 %
Indice di Wobbe Inferiore			0.00 %
Massa molare			0.11 %
Fattore di compressione (Z)			0.92 %
Volume molare	0.023594 m ³ /mol	Anidride carbonica	0.31 %
Densità relativa	0.5819	Ossigeno	0.00 %
Densità	0.7131 kg/m ³	Idrogeno	0.00 %
T1: 15.00 °C	T2: 15.00 °C	Totale grezzo	100.50 %



The screenshot shows the 'Storico delle analisi' interface with the final analysis data table displayed. The table is divided into two columns. The left column contains general analysis parameters, and the right column contains the composition of the gas mixture. The 'ESPORTA' button at the bottom is highlighted with an orange box.

2024-11-25 12:08:27		3076 mBar (A) 23.6 °C	
Potere Calorifico Superiore	38.508 MJ/Sm ³	Metano	95.48 %
Potere Calorifico Inferiore	34.709 MJ/Sm ³	Etano	2.52 %
Indice di Wobbe	50.481 MJ/Sm ³	Propano	0.67 %
Indice di Wobbe Inferiore	45.501 MJ/Sm ³	n-Butano	0.00 %
Massa molare	16.825 kg/kmol	i-Butano	0.11 %
Fattore di compressione (Z)	0.99786	Azoto	0.92 %
Volume molare	0.023594 m ³ /mol	Anidride carbonica	0.31 %
Densità relativa	0.5819	Ossigeno	0.00 %
Densità	0.7131 kg/m ³	Idrogeno	0.00 %
T1: 15.00 °C	T2: 15.00 °C	Totale grezzo	100.50 %

5.4.4 - EVENT SEARCH

Events include all activities performed by both the GEDRA system and the users accessing it.

These events include, for example:

- changing the system time,
- user login and logout,
- changing the system date etc.

Every action is logged to ensure complete monitoring of operations and interactions with the system.

An event corresponds to a single line and includes the parameters:

- event identifier element: 4 digits representing the progressive serial number of the event (in case the events are deleted, the counting starts again from number 1);
- day and time: day and time the event occurred;
- user: the user who created the event;
- description: brief description of the event that occurred;
- original value: value prior to the modification of the parameter in question;
- modified value: value after the modification of the parameter in question;

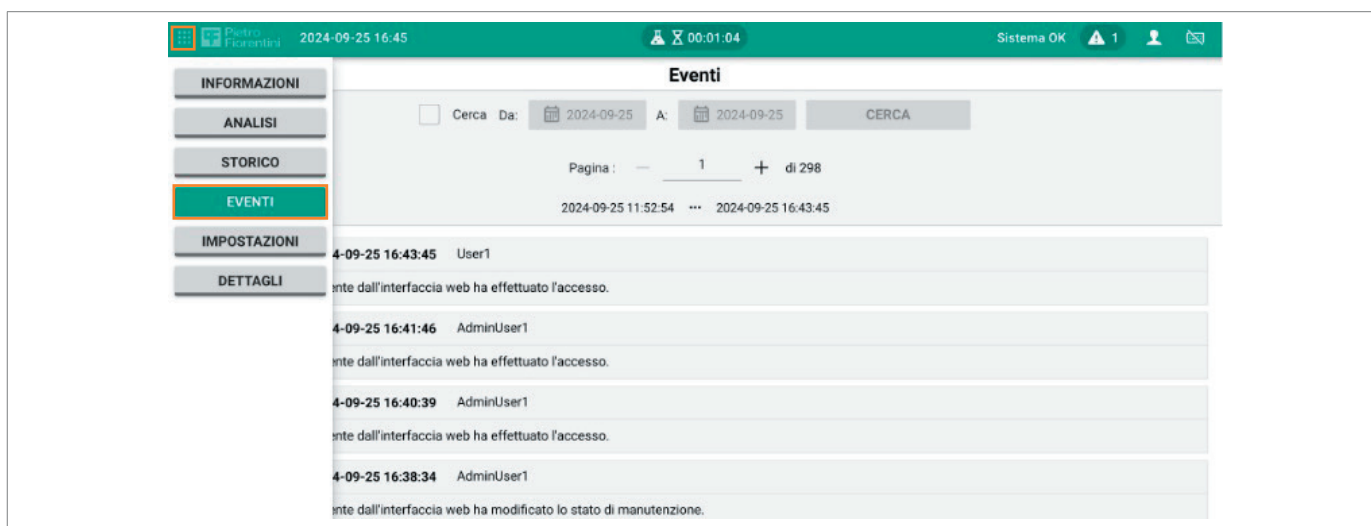

1. Access the “Menu” section by clicking the first icon on the left, next to the Pietro Fiorentini logo
2. Click on the “Events” button
3. Use the “+” or “-” buttons to navigate the results pages
4. Check the “Search” box to search for a specific event, indicating the time range

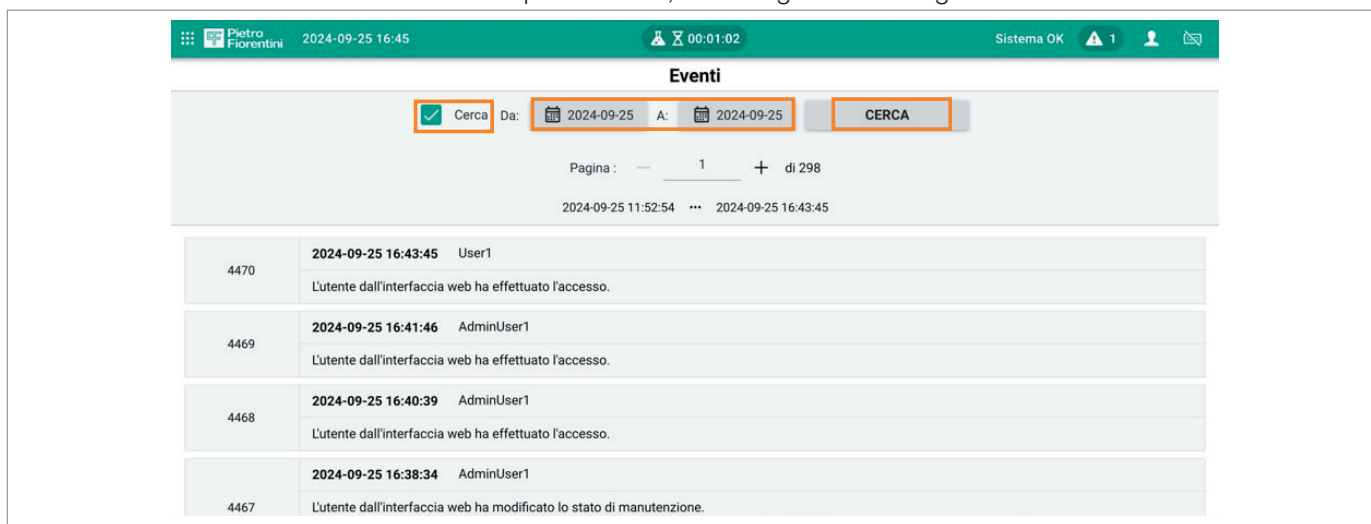

5. Choose the desired date from the calendar that will appear on the screen

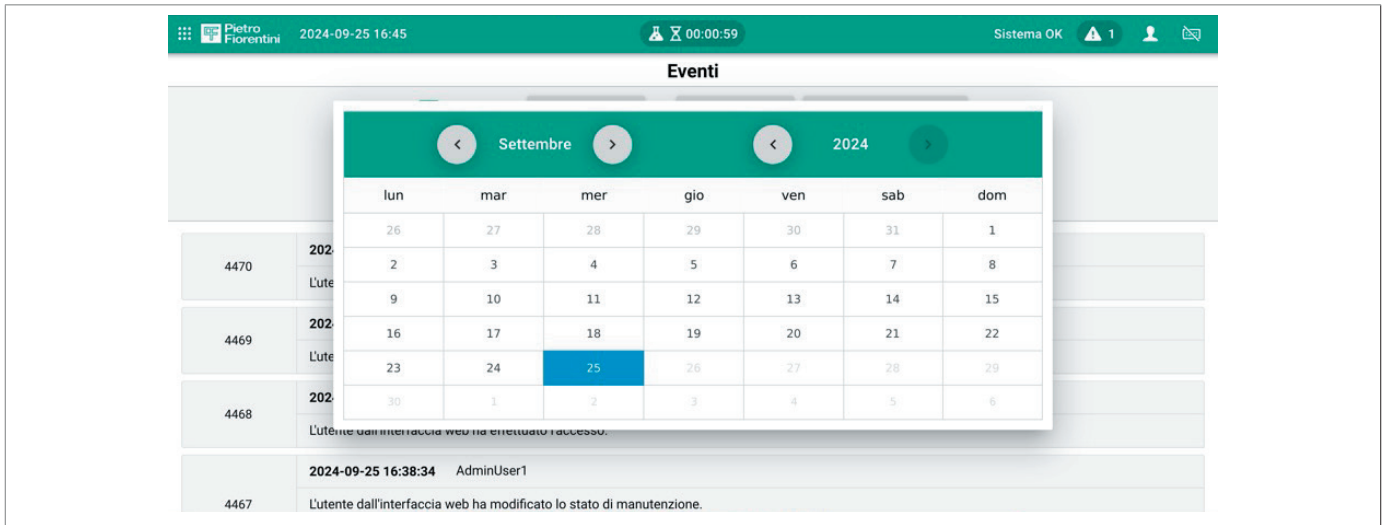

6. Confirm this action by clicking the “Search” button

7. Click on the “Export” button to obtain an Excel file with the analysis data for the selected period

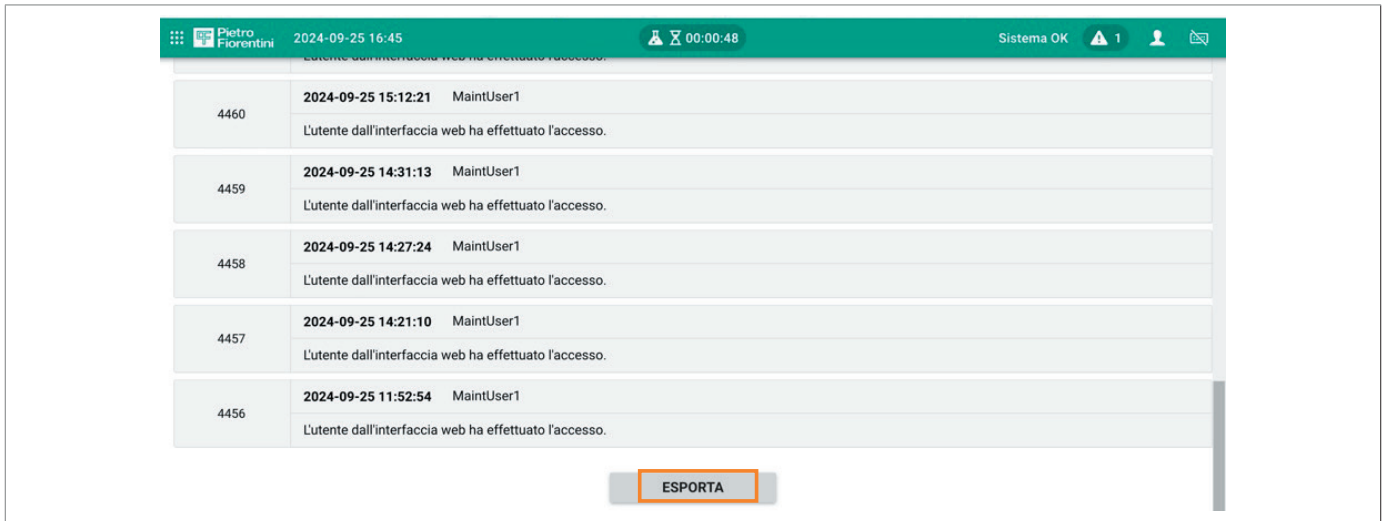

The memory of the GEDRA is limited. Once the maximum number of recorded events is reached, the device will continue to function properly, but will automatically log you out of your user account.

To restore the correct functioning of the equipment, you must log in with the “administrator” or “proprietary” profile and reset the saved events.

5.4.5 - SETTINGS

In this section you can view the selected settings. With the “user” profile it is not possible to modify them.

1. Access the “Menu” section by clicking the first icon on the left, next to the Pietro Fiorentini logo
2. Click on the “Settings” button



5.4.5.1 - SYSTEM

In this section you can view information about your system:

- maintenance mode (enabled/disabled): identifies whether maintenance mode is active or not
- system language: displays the language set in the user interface
- daylight saving (yes/no): identifies whether daylight saving time is active or not
- system time zone: displays the system time zone
- maximum maintenance time: identifies the maximum time in maintenance mode
- unit of measurement of temperature
- unit of measurement of pressure
- operating pressure: indicates the gas pressure in the analysis cell
- solenoid valve present (yes/no): identifies the presence or absence of the solenoid valve that cuts off the passage of gas from the pneumatic panel to the analysis unit cell
- washing time: if the solenoid valve is present, it indicates the time required to wash the analysis circuit in order to have "fresh" gas
- solenoid valve open during analysis (yes/no): if the solenoid valve is present, indicates whether or not it was open during the analysis.





Parametro	Valore
Lingua del sistema	Italiano
Ora legale	SI
Fuso orario del sistema	Europe Rome
Data del sistema	2024-09-25
Ora del sistema	16:46
Tempo di manutenzione	60 min
Unità di misura della temperatura	°C
Unità di misura della pressione	mBar (A)
Pressione di esercizio	1500.0 mBar (A)
Elettrovalvola presente	SI
Tempo di lavaggio	15 s
Elettrovalvola aperta durante l'analisi	No

5.4.5.2 - ANALYSIS SETTINGS

This section displays:

- unit of measurement in which the value of the Higher Calorific Value (HCV) is reported
- unit of measurement of reference Temperatures (T1 and T2). T1 and T2 are respectively the combustion temperature (temperature at which a fuel starts to burn) and the volume measurement temperature (temperature at which the volume of the fuel is measured), defined according to UNI EN 6976.
- analysis interval (in seconds): identifies the period of time between one analysis and the next
- calibration verification validity (in days): identifies the maximum number of days that can elapse between two metrological verifications. It must match what is indicated on the metrological certificate.



Impostazioni

SISTEMA ANALISI ALLARMI

SERIALE <-> ETHERNET

Unità di misura del PCS	MJ/Sm ³
Temperature di riferimento	mBar (A)
Intervallo di analisi	30 s
Validità della verifica	365 giorni

5.4.5.3 - ALARMS

In this section you can access the alarm display menu by clicking on the “alarms” item. In the following section, if present, the alarm limits that define warnings of the GEDRA output parameters are visible.

The alarm limits, for applications in Italian territory, are defined by the SNAM network code.



The screenshot shows the 'Impostazioni' (Settings) menu with the following options: SISTEMA, ANALISI, ALLARMI (highlighted), SERIALE, and ETHERNET. Below the menu, there are several parameter settings for alarm limits:

Superior Calorific Value		
⬇️	⬆️	MJ/Sm ³
Inferior Calorific Value		
⬇️	⬆️	MJ/Sm ³
Wobbe index		
⬇️	⬆️	MJ/Sm ³

Methane		
⬇️	⬆️	%
Ethane		
⬇️	⬆️	%
Propane		
⬇️	⬆️	%

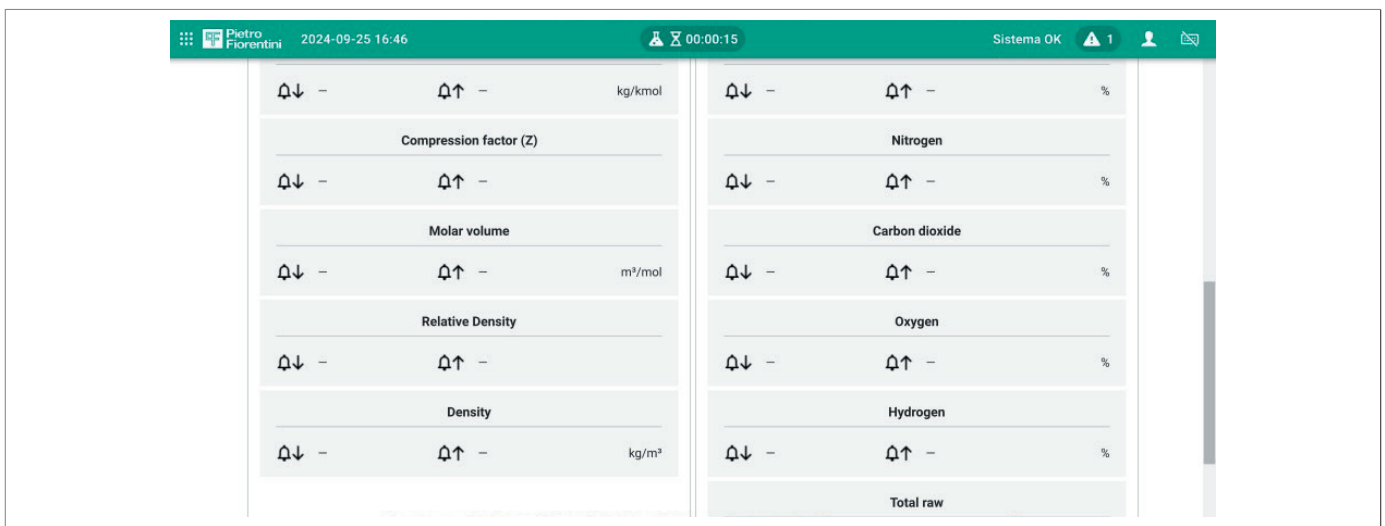

The screenshot shows the 'Impostazioni' (Settings) menu with various gas quality parameters:

⬇️	⬆️	kg/kmol
Compression factor (Z)		
⬇️	⬆️	
Molar volume		
⬇️	⬆️	m ³ /mol
Relative Density		
⬇️	⬆️	
Density		
⬇️	⬆️	kg/m ³

⬇️	⬆️	%
Nitrogen		
⬇️	⬆️	%
Carbon dioxide		
⬇️	⬆️	%
Oxygen		
⬇️	⬆️	%
Hydrogen		
⬇️	⬆️	%
Total raw		

If limits are set on the parameters and these values are not respected, the parameters in alarm will be displayed in red on the “Analysis” page.

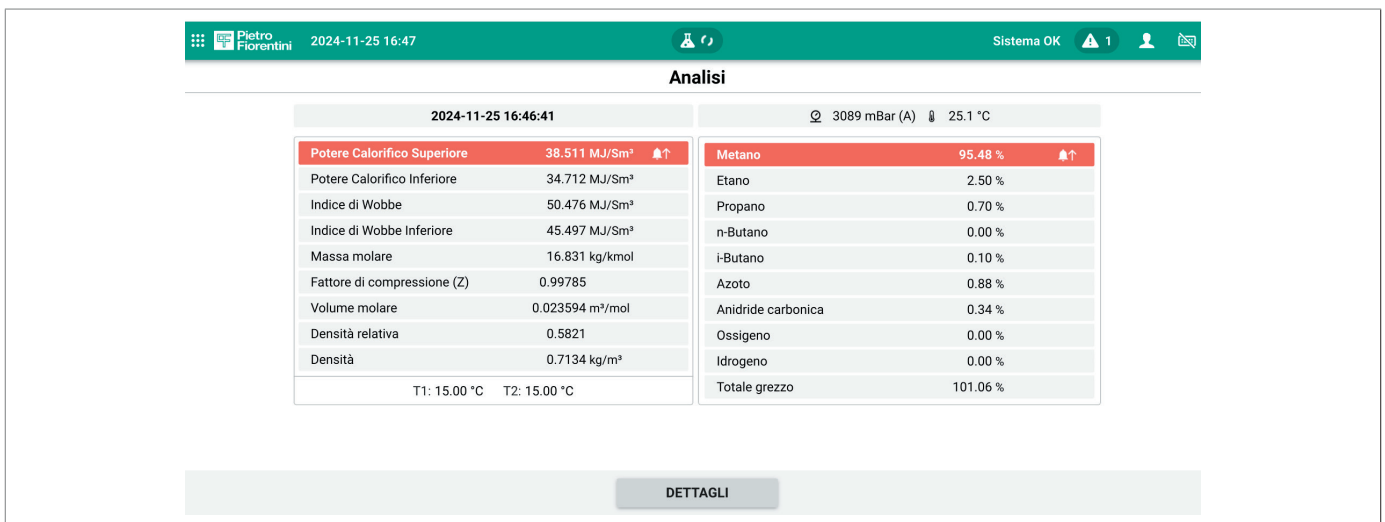

The screenshot shows the 'Analisi' (Analysis) page with the following data:

2024-11-25 16:46:41		3089 mBar (A) 25.1 °C	
Potere Calorifico Superiore	38.511 MJ/Sm ³	⬆️	⬆️
Potere Calorifico Inferiore	34.712 MJ/Sm ³		
Indice di Wobbe	50.476 MJ/Sm ³		
Indice di Wobbe Inferiore	45.497 MJ/Sm ³		
Massa molare	16.831 kg/kmol		
Fattore di compressione (Z)	0.99785		
Volume molare	0.023594 m ³ /mol		
Densità relativa	0.5821		
Densità	0.7134 kg/m ³		
T1: 15.00 °C T2: 15.00 °C			

Metano		95.48 %	⬆️
Etano		2.50 %	
Propano		0.70 %	
n-Butano		0.00 %	
i-Butano		0.10 %	
Azoto		0.88 %	
Anidride carbonica		0.34 %	
Ossigeno		0.00 %	
Idrogeno		0.00 %	
Totale grezzo		101.06 %	

DETTAGLI

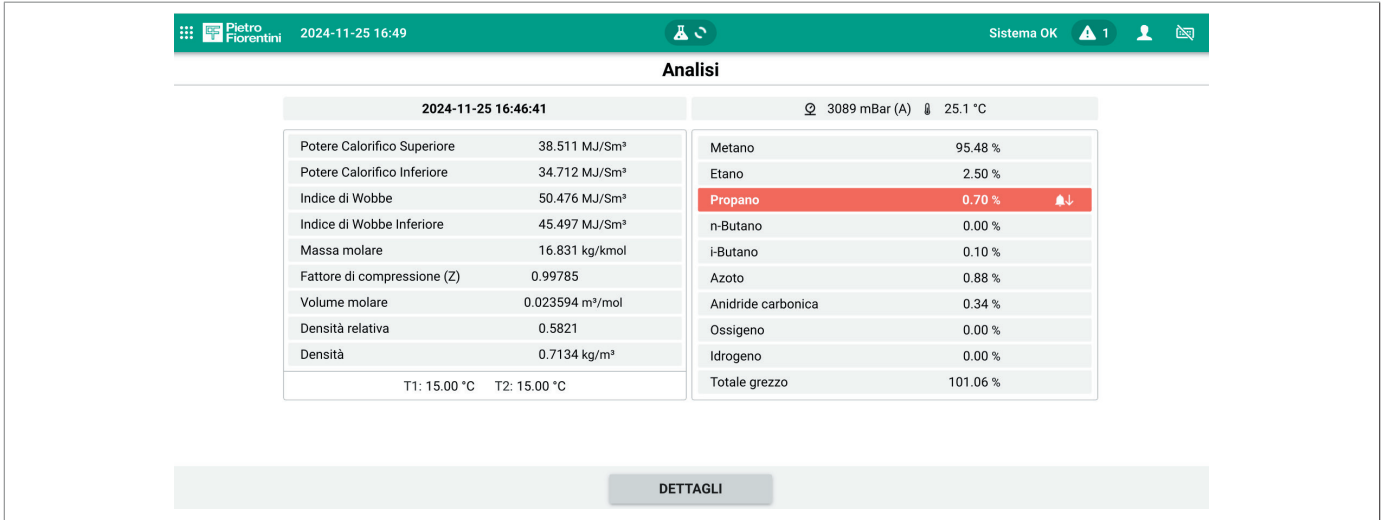

Analisi

2024-11-25 16:46:41 3089 mBar (A) 25.1 °C

Potere Calorifico Superiore	38.511 MJ/Sm ³	Metano	95.48 %
Potere Calorifico Inferiore	34.712 MJ/Sm ³	Etano	2.50 %
Indice di Wobbe	50.476 MJ/Sm ³	Propano	0.70 % ↓
Indice di Wobbe Inferiore	45.497 MJ/Sm ³	n-Butano	0.00 %
Massa molare	16.831 kg/kmol	i-Butano	0.10 %
Fattore di compressione (Z)	0.99785	Azoto	0.88 %
Volume molare	0.023594 m ³ /mol	Anidride carbonica	0.34 %
Densità relativa	0.5821	Ossigeno	0.00 %
Densità	0.7134 kg/m ³	Idrogeno	0.00 %
T1: 15.00 °C T2: 15.00 °C		Totale grezzo	101.06 %

DETTAGLI

The previous image shows an example in which the Higher Calorific Value parameter and the composition of the methane exceed the limit value imposed in the alarm (the upward arrow indicates that the value is higher than the imposed limit).

5.4.5.4 - SERIAL

In this section you can view the parameters set for the four RS485 serial ports.

For each of the four ports you can view:

- port status: active/inactive
- transmission speed;
- type of “protocol”;
- presence or absence of the “Flowcomputer”: Yes/No (it is linked to whether or not the GEDRA is connected to the flow computer);
- enter the item referring to the map type, whether Modbus RTU or ASCII

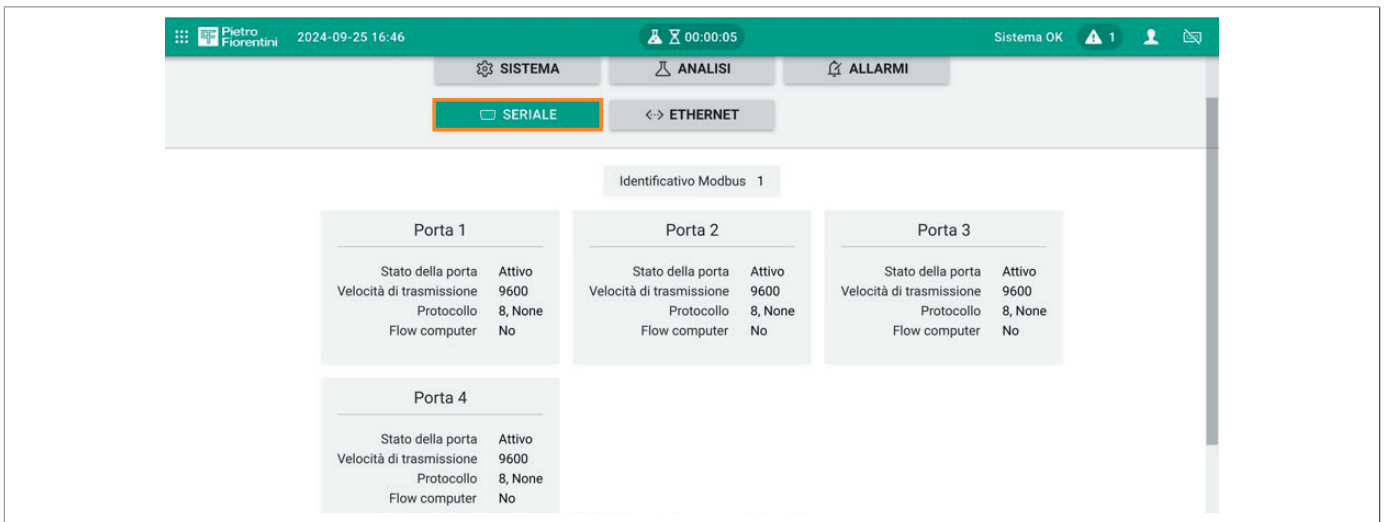

SERIALE

Identificativo Modbus 1

Porta 1	Porta 2	Porta 3	Porta 4
Stato della porta	Attivo	Stato della porta	Attivo
Velocità di trasmissione	9600	Velocità di trasmissione	9600
Protocollo	8, None	Protocollo	8, None
Flow computer	No	Flow computer	No

5.4.5.5 - ETHERNET

In this section you can view the parameters:

- address: MAC (Media Access Control) address, a unique identifier assigned to each networked device
- prefix length: number of bits that make up the network part of an IP address
- gateway: access point that allows communication between two different networks

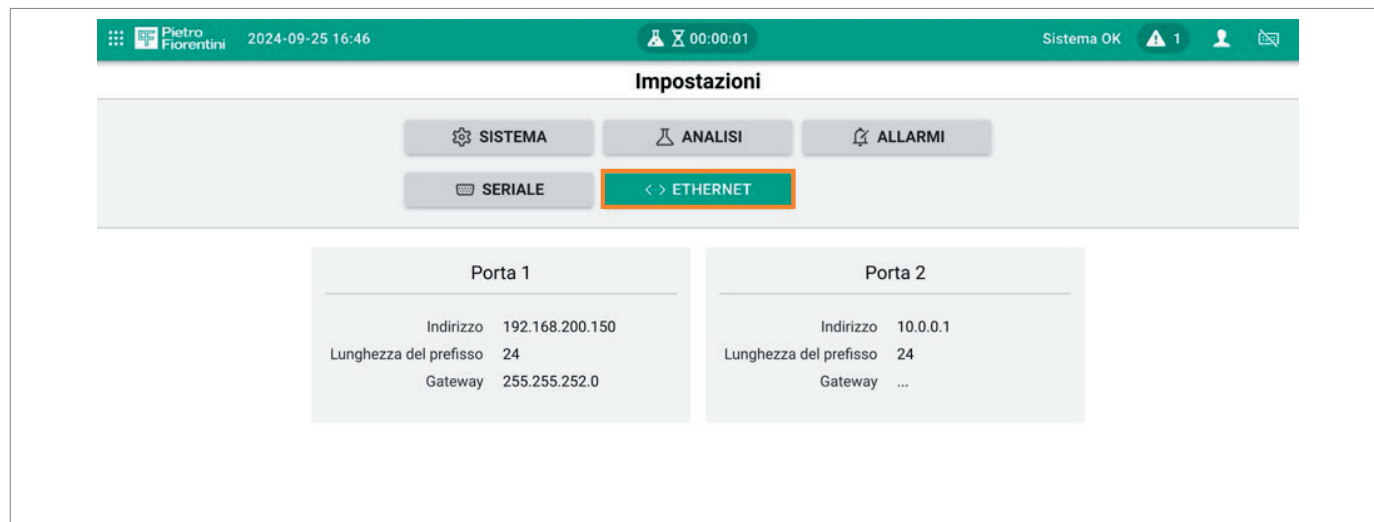

Impostazioni

SISTEMA ANALISI ALLARMI

SERIALE **ETHERNET**

Porta 1		Porta 2	
Indirizzo	192.168.200.150	Indirizzo	10.0.0.1
Lunghezza del prefisso	24	Lunghezza del prefisso	24
Gateway	255.255.252.0	Gateway	...

5.4.6 - DETAILS

In this section you can view

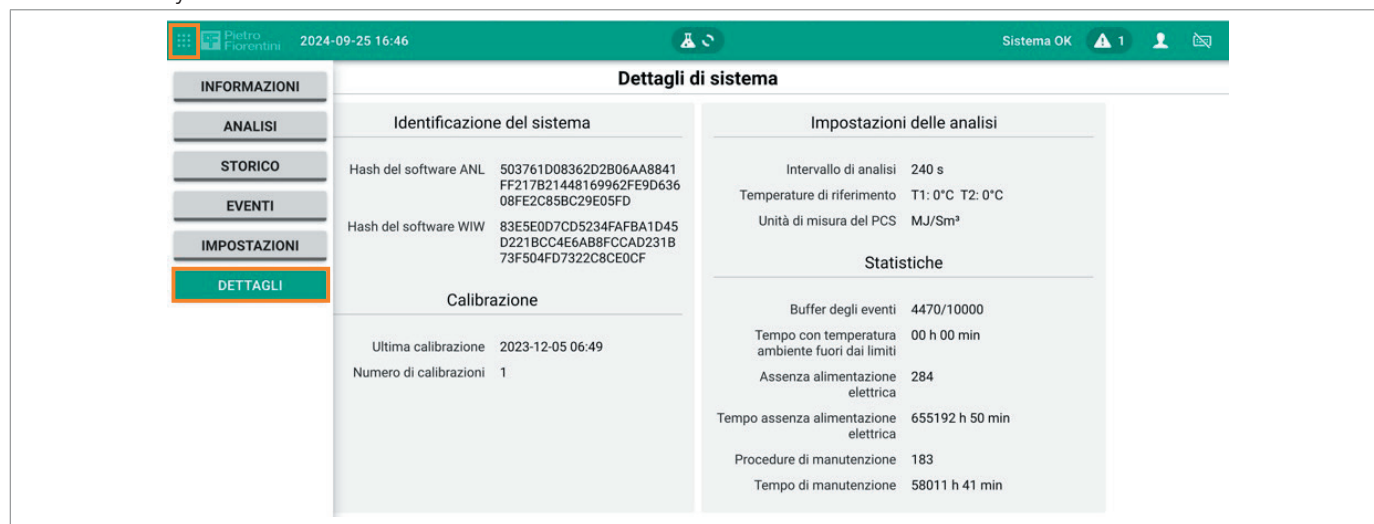

Dettagli di sistema

INFORMAZIONI ANALISI STORICO EVENTI IMPOSTAZIONI **DETTAGLI**

Identificazione del sistema		Impostazioni delle analisi	
Hash del software ANL	503761D08362D2B06AA8841 FF217B21448169962FE9D636 08FE2C85BC29E05FD	Intervallo di analisi	240 s
Hash del software WIW	83E5E0D7CD5234FABFA1D45 D221BCC4E6AB8FCCAD231B 73F504FD7322C8CE0CF	Temperature di riferimento	T1: 0°C T2: 0°C
		Unità di misura del PCS	MJ/Sm³
Calibrazione		Statistiche	
Ultima calibrazione	2023-12-05 06:49	Buffer degli eventi	4470/10000
Numero di calibrazioni	1	Tempo con temperatura ambiente fuori dai limiti	00 h 00 min
		Assenza alimentazione elettrica	284
		Tempo assenza alimentazione elettrica	655192 h 50 min
		Procedure di manutenzione	183
		Tempo di manutenzione	58011 h 41 min

SYSTEM IDENTIFICATION

- ANL software hash: this is a value used to verify integrity and ensure that the ANL software has not been altered or corrupted. Hashes are used for security and version management.
- WIW software hash: this is a value used to verify integrity and ensure that the WIW software has not been altered or corrupted, allowing for the identification of changes or errors in the files.

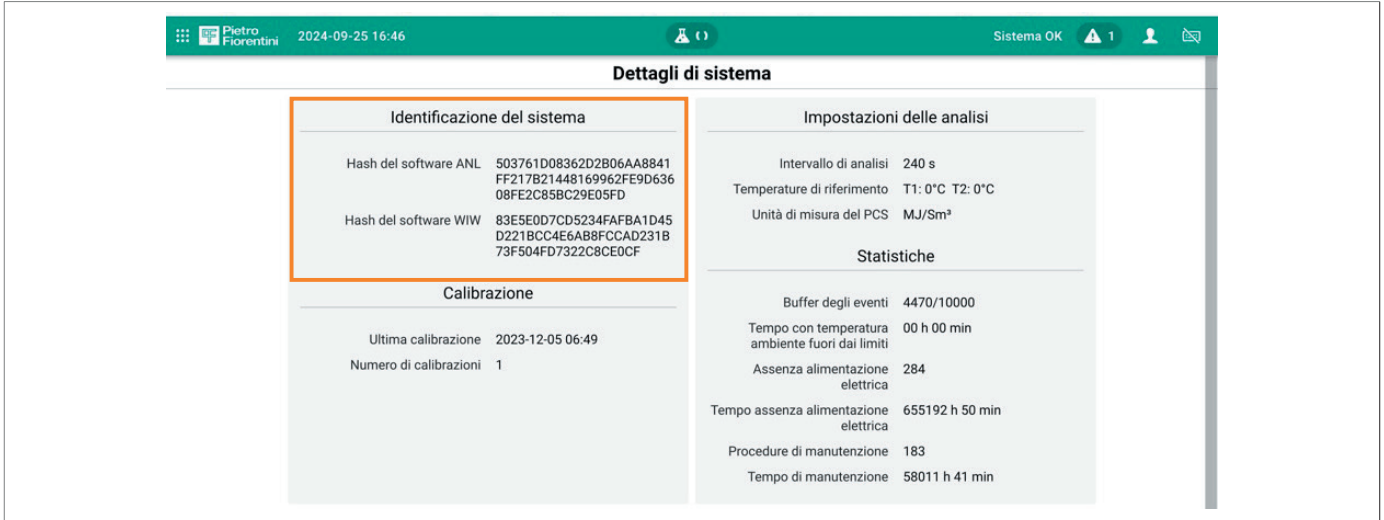

The screenshot shows the 'Dettagli di sistema' (System Details) page. The 'Identificazione del sistema' (System Identification) section is highlighted with an orange border. It contains the following information:

Identificazione del sistema	
Hash del software ANL	503761D08362D2B06AA8841 FF217B21448169962FE9D636 08FE2C85BC29E05FD
Hash del software WIW	83E5E0D7CD5234FAFBA1D45 D221BCC4E6AB8FCCAD231B 73F504FD7322C8CE0CF

Other sections visible include 'Impostazioni delle analisi' (Analysis Settings) and 'Calibrazione' (Calibration).

ANALYSIS SETTINGS

- Analysis interval: identifies the period of time between the end of one analysis and the beginning of the next
- Reference temperature: identifies the values and unit of measurement of the reference temperatures T1 and T2.
- T1 and T2 are respectively the combustion temperature (temperature at which a fuel starts to burn) and the volume measurement temperature (temperature at which the volume of the fuel is measured), defined according to UNI EN 6976.
- PCS unit of measure: identifies the unit of measurement of the Higher Calorific Value (HCV)

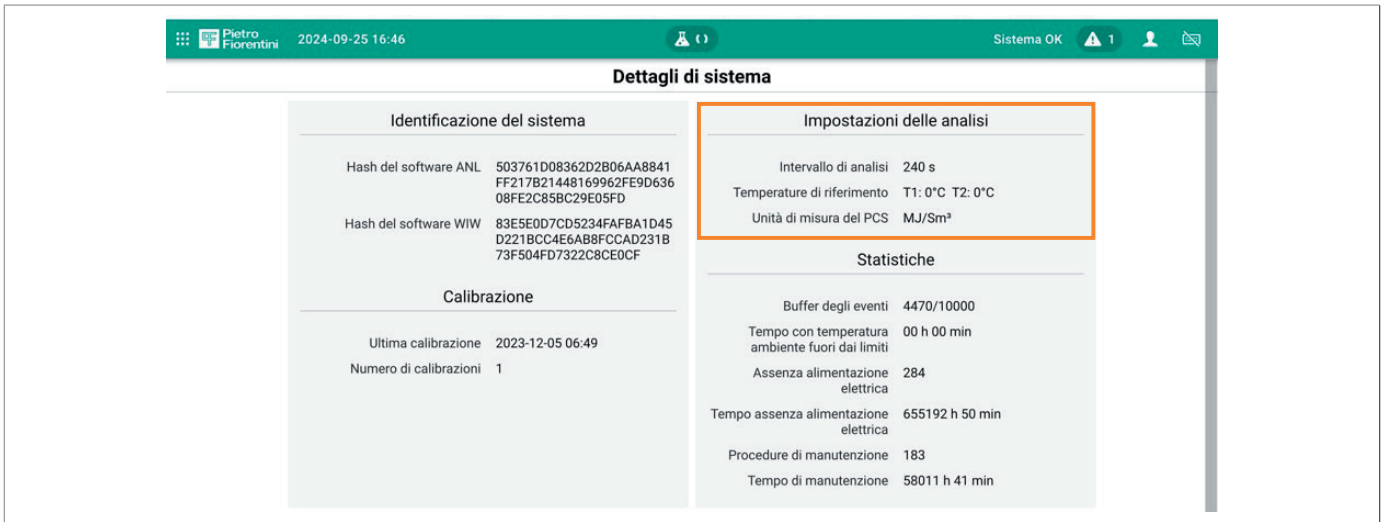

The screenshot shows the 'Dettagli di sistema' (System Details) page. The 'Impostazioni delle analisi' (Analysis Settings) section is highlighted with an orange border. It contains the following information:

Impostazioni delle analisi	
Intervallo di analisi	240 s
Temperature di riferimento	T1: 0°C T2: 0°C
Unità di misura del PCS	MJ/Sm ³

Other sections visible include 'Identificazione del sistema' (System Identification) and 'Statistiche' (Statistics).

STATISTICS

- Events buffer: identifies the number of events executed within the system compared to the maximum storage capacity
- Time with system temperature out of limits: identifies the time (in hours and minutes) in which the system temperature (internal temperature) exceeds the limits
- No power supply: indicates the number of times the power supply to the GEDRA was down
- No power supply time: indicates the time (in hours and minutes) during which the GEDRA power supply was down
- Maintenance procedure: Indicates the total number of times maintenance mode has been activated in the system
- Maintenance time: indicates the time (in hours and minutes) that maintenance mode was activated in the system

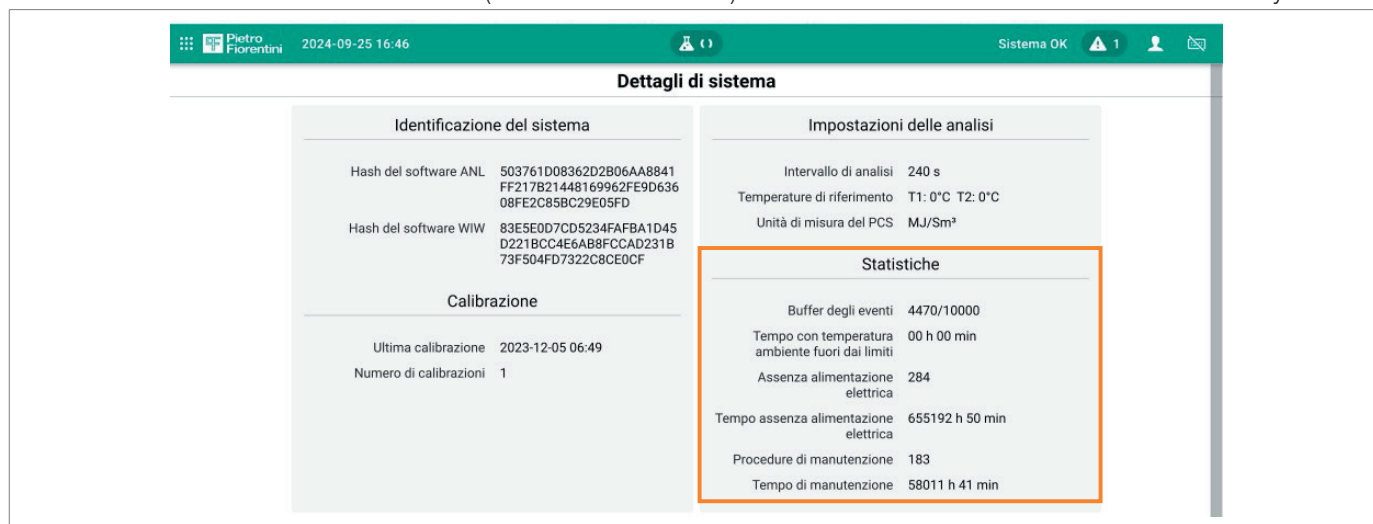

The screenshot displays the 'Dettagli di sistema' (System Details) page. The top navigation bar shows the date and time as 2024-09-25 16:46, the system status as 'Sistema OK', and a notification icon with the number '1'. The main content is divided into three sections: 'Identificazione del sistema', 'Impostazioni delle analisi', and 'Statistiche'. The 'Statistiche' section is highlighted with an orange border and contains the following data:

Statistiche	
Buffer degli eventi	4470/10000
Tempo con temperatura ambiente fuori dai limiti	00 h 00 min
Assenza alimentazione elettrica	284
Tempo assenza alimentazione elettrica	655192 h 50 min
Procedure di manutenzione	183
Tempo di manutenzione	58011 h 41 min

5.5 - OPERATIONS PERMITTED BY THE “MAINTENANCE TECHNICIAN” PROFILE

The “maintenance technician” profile can perform all the functions previously listed for the user profile, to which are added those listed in this chapter.

5.5.1 - SETTINGS

In the “SETTINGS” section, the Maintenance Technician profile has the ability to modify the system parameters. Unlike the user profile, which is ready-only.

From the left menu, click the “dotted square” next to the Pietro Fiorentini logo, and select “SETTINGS”. In this section you can change the device parameters.

Each change made (multiple changes can be made on the same page) requires confirmation by saving. Only after saving will the change be applied and made effective in the system. Without saving, the changes you make will not be saved.

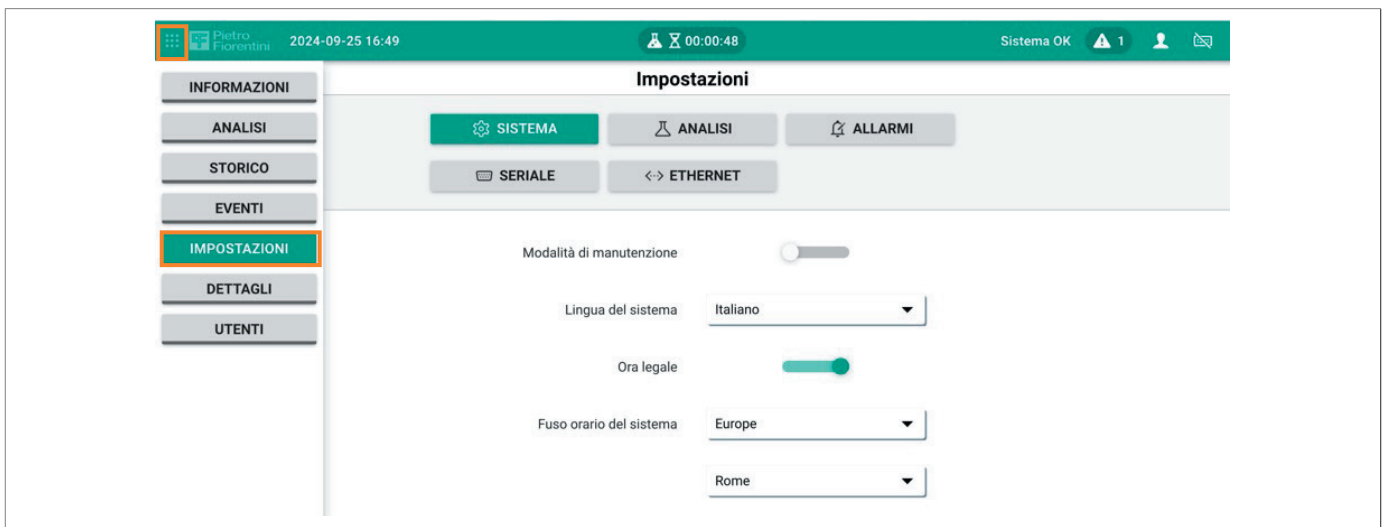

If you make changes without clicking the save or cancel button, you will get the following error: "There are unsaved settings parameters for the following sections: System".



5.5.1.1 - SYSTEM

In this "System" section you can set:

- Maintenance mode
- System language;
- DST time change;
- System area;
- Maximum maintenance time;
- Unit of measurement of temperature;
- Unit of measurement of pressure;
- GEDRA operating pressure;
- Presence of "EV" solenoid valve;
- "EV" solenoid valve flushing time;
- EV solenoid valve opening during analysis

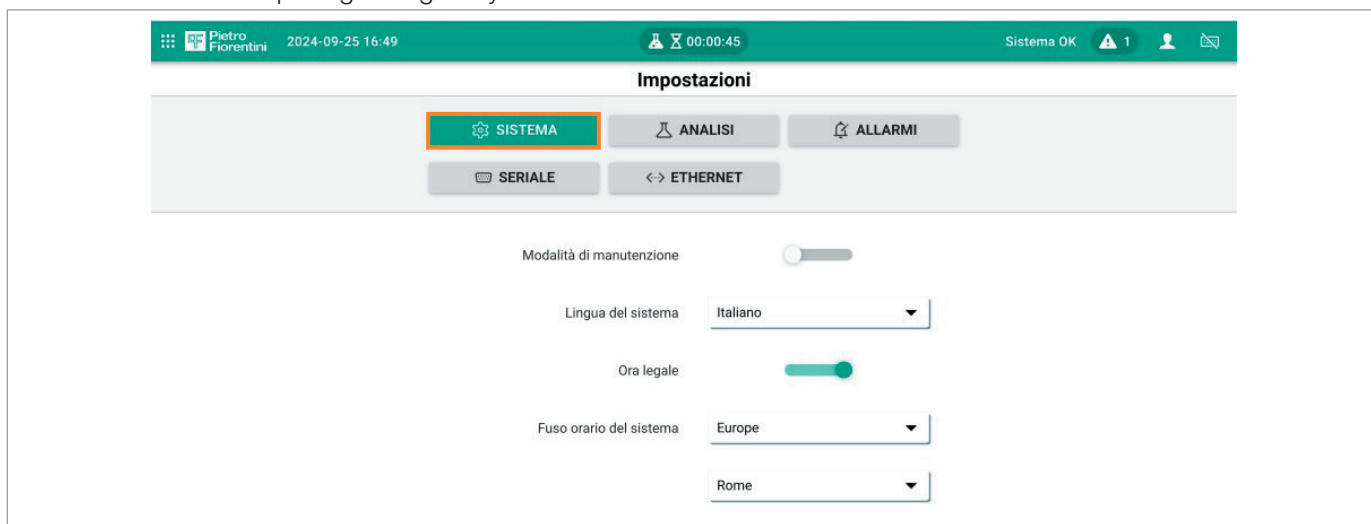

MAINTENANCE MODE

Maintenance mode allows you to perform technical interventions on the system, such as periodic calibration or changing critical parameters, such as alarm limits (refer to paragraphs 5.1.3.1.3 ALARMS and 5.1.3.3 VERIFICATION).

By dragging the “Maintenance Mode” button and saving the changes, the central bar will turn yellow to indicate that the maintenance state is active.

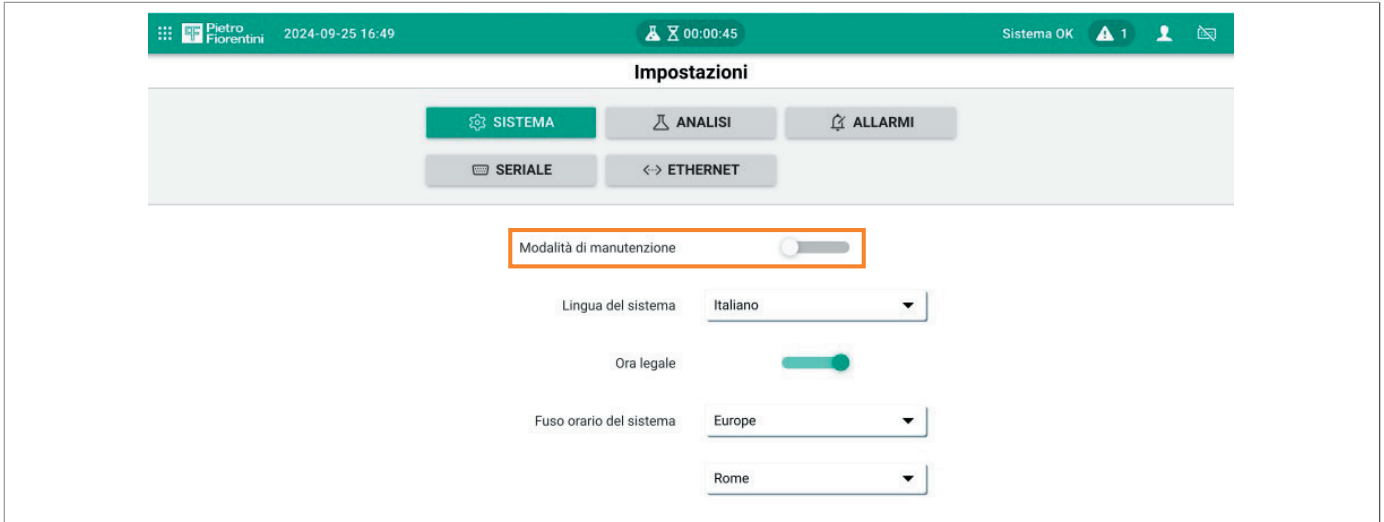

There is a maximum activation time in maintenance mode. Once this predefined time interval has elapsed, the system will automatically disable maintenance mode, restoring normal operation without the need for manual intervention. Alternatively, if the maintenance operation is completed before this activation time, manually disable and drag “maintenance mode” again.

Paragraphs 5.1.3.1.3 Alarms and 5.1.3.3 Verification report the detailed operations that can be performed using maintenance mode.

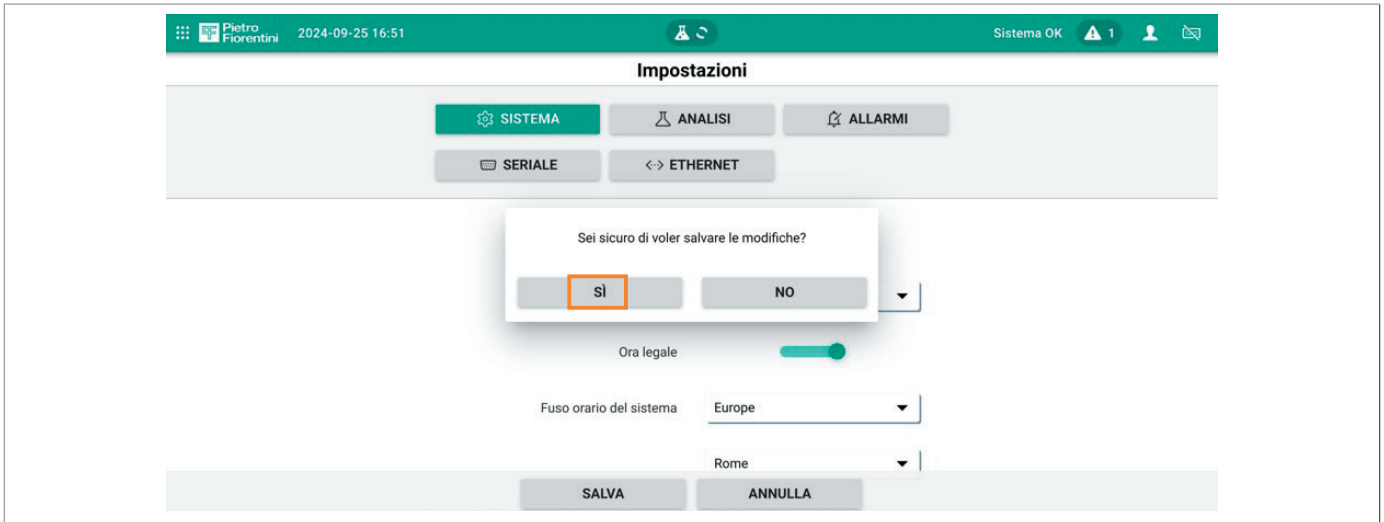

After saving the changes, the central bar changes colour from green to yellow, indicating that maintenance mode is activated. The bar also shows the time remaining before maintenance mode is automatically deactivated. The following paragraphs will show you how to change this duration.

This allows users to easily monitor the maintenance duration and ensures that the GEDRA resumes its regular operation without further intervention.

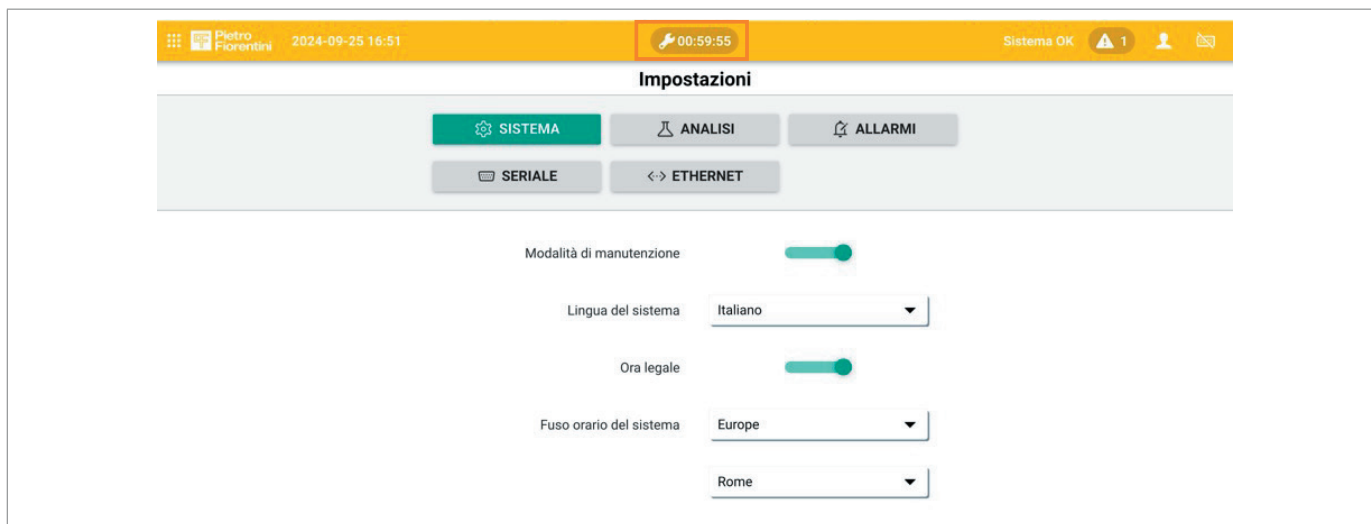

SYSTEM LANGUAGE

In the following section you can select the system language.

The possible languages to select are the following:

- English (USA)
- German
- Spanish (Spain)
- French
- Italian
- Dutch

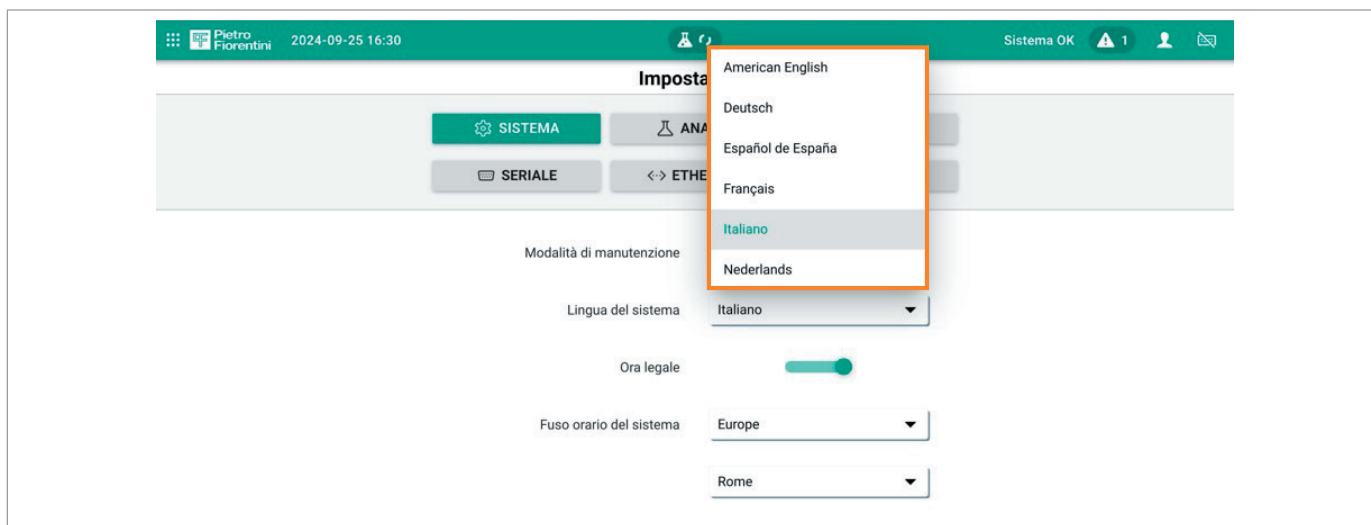

DAYLIGHT SAVING TIME

In the following section you can select daylight saving time. If activated, the machine will automatically activate and deactivate daylight saving time according to the international calendar. The time will be updated at 6:00 am on the day the change is scheduled, as established by the Snam network code

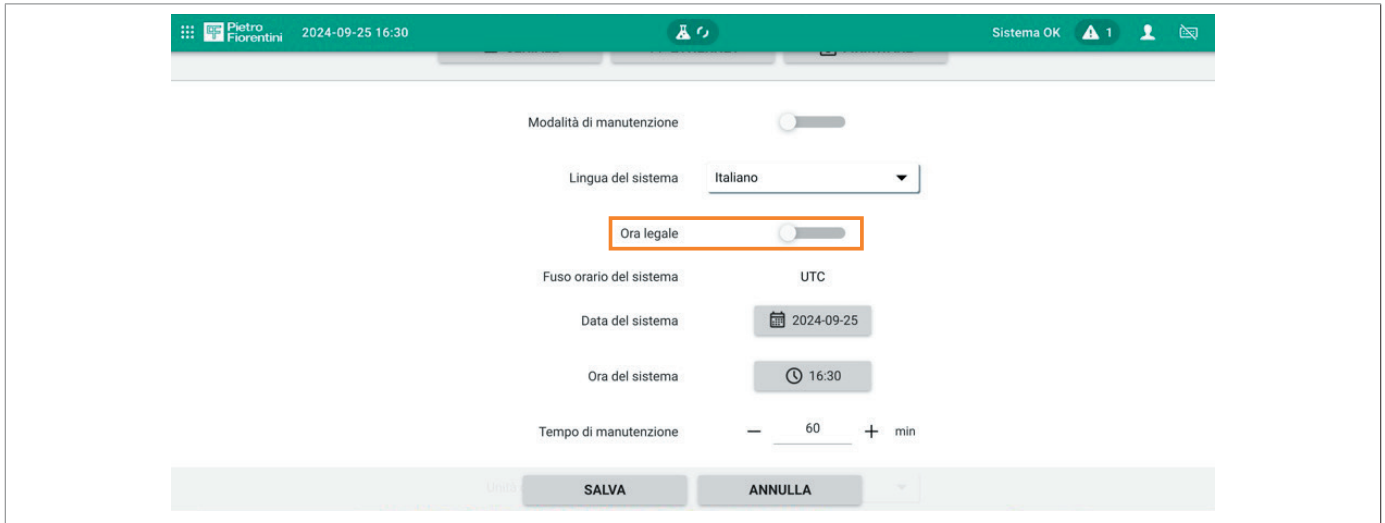

SYSTEM TIME ZONE

In the following section you can select the time zone relating to the GEDRA installation area.

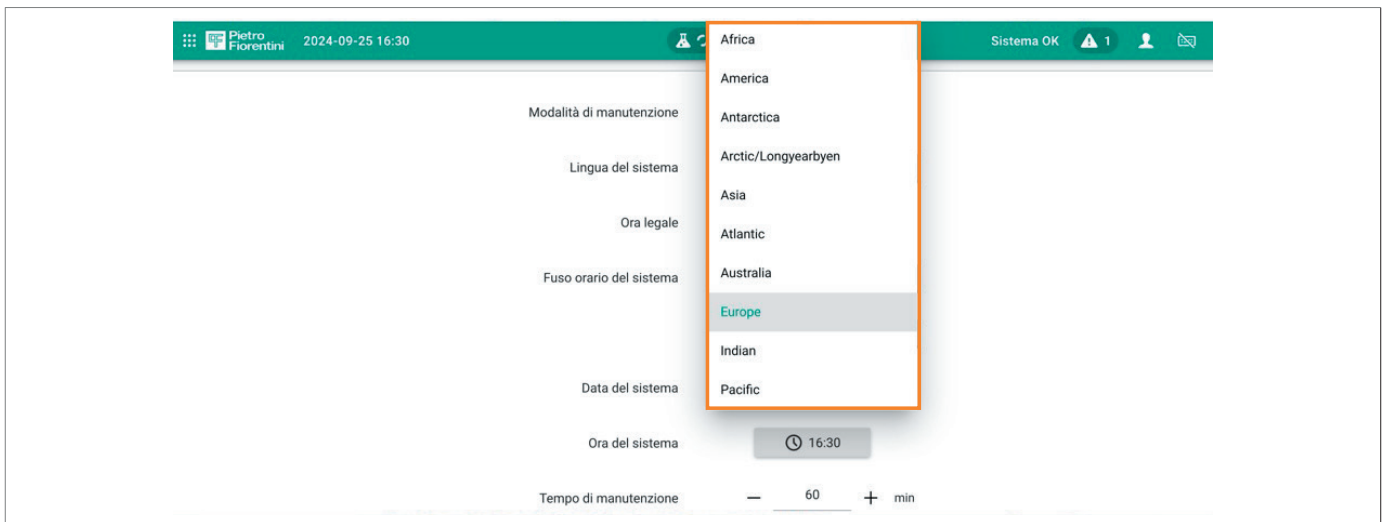

SYSTEM DATE

By clicking "system date", you will be able to select the system date.

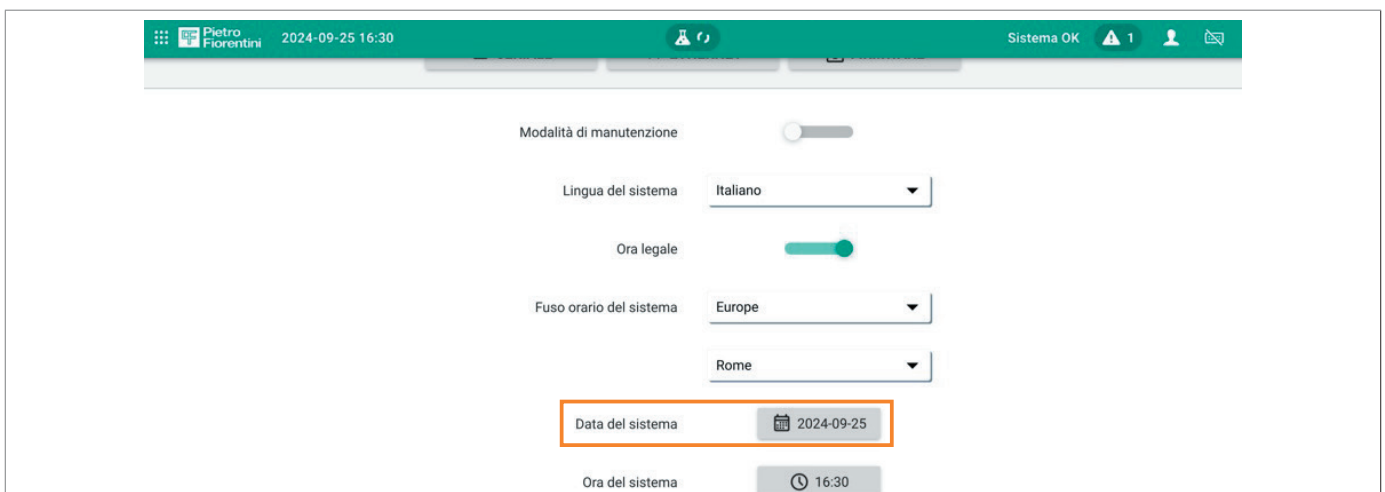

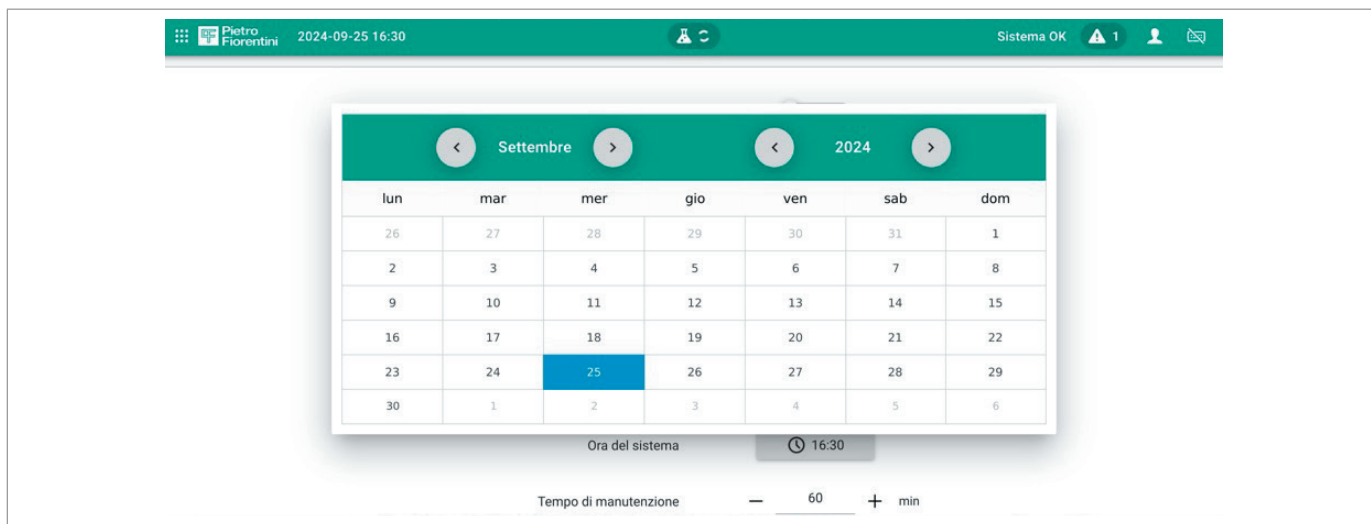

SYSTEM TIME

By clicking "system date", you will be able to select the system time.

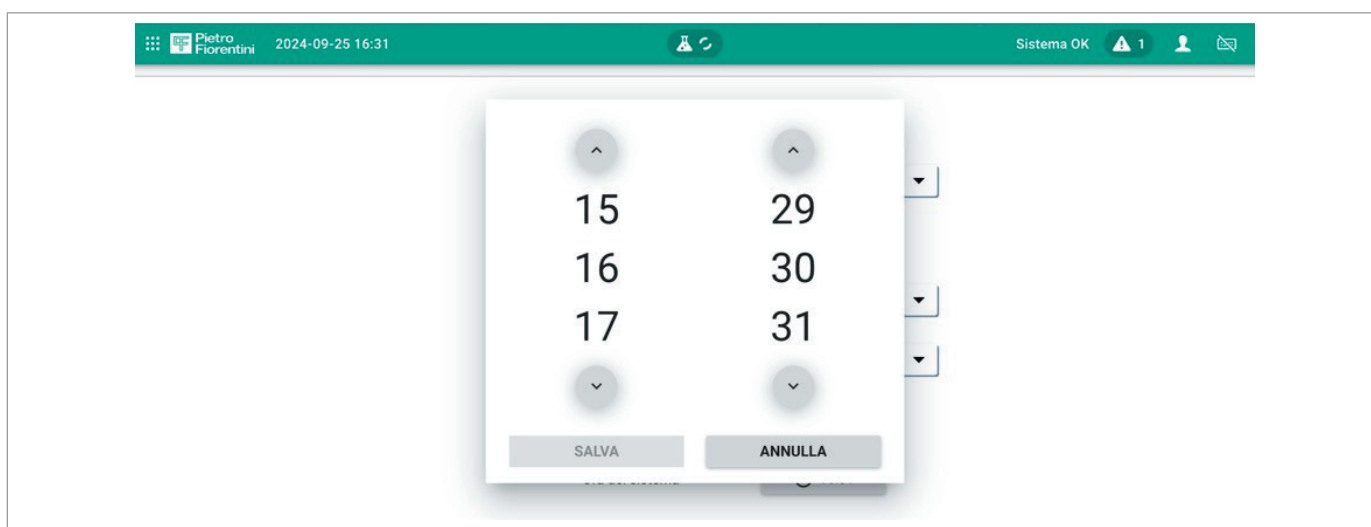
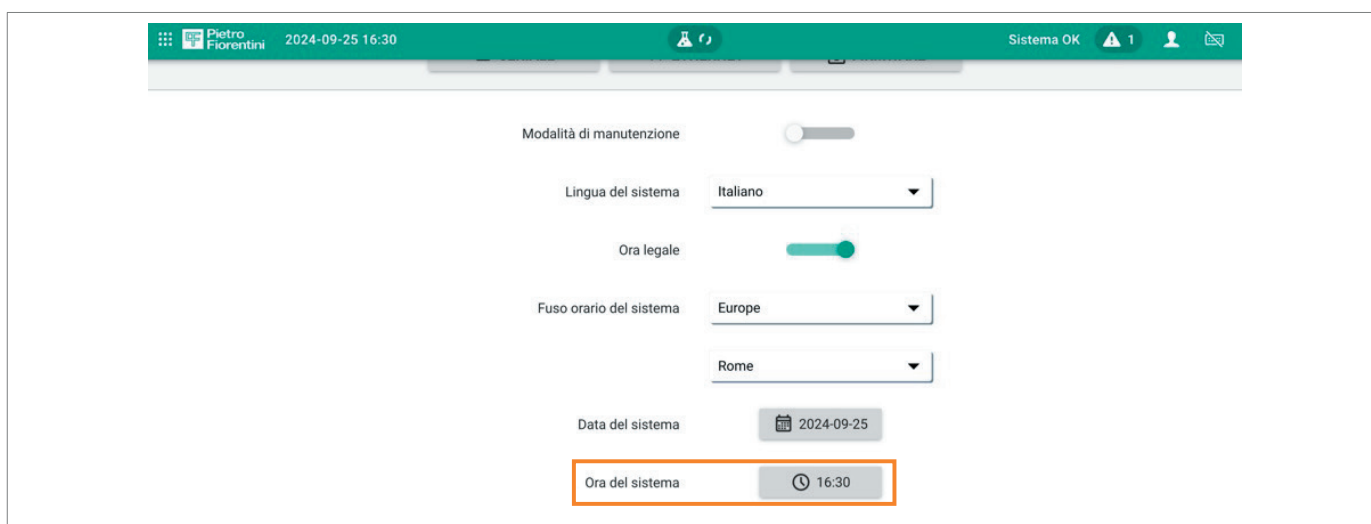

MAINTENANCE TIME

In this section you can set and select the duration of the maintenance mode. The maintenance technician can change the length of time the system will remain in maintenance mode before automatically returning to normal operating mode. During maintenance mode, the gas quality analysis is temporarily suspended.

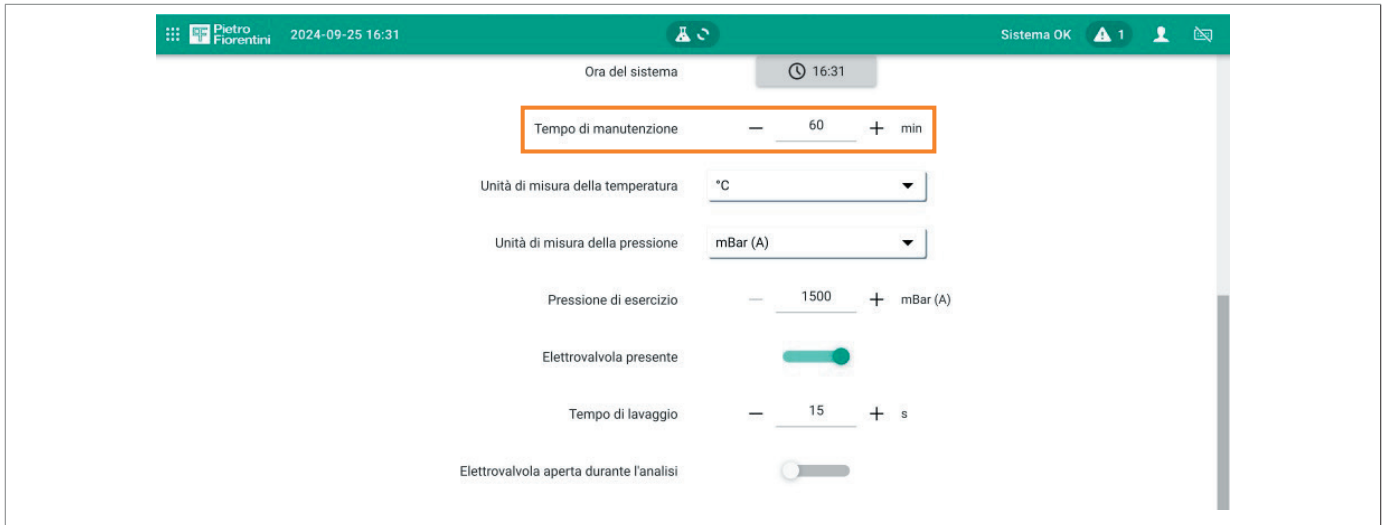

UNIT OF MEASUREMENT OF TEMPERATURE



UNIT OF MEASUREMENT OF PRESSURE

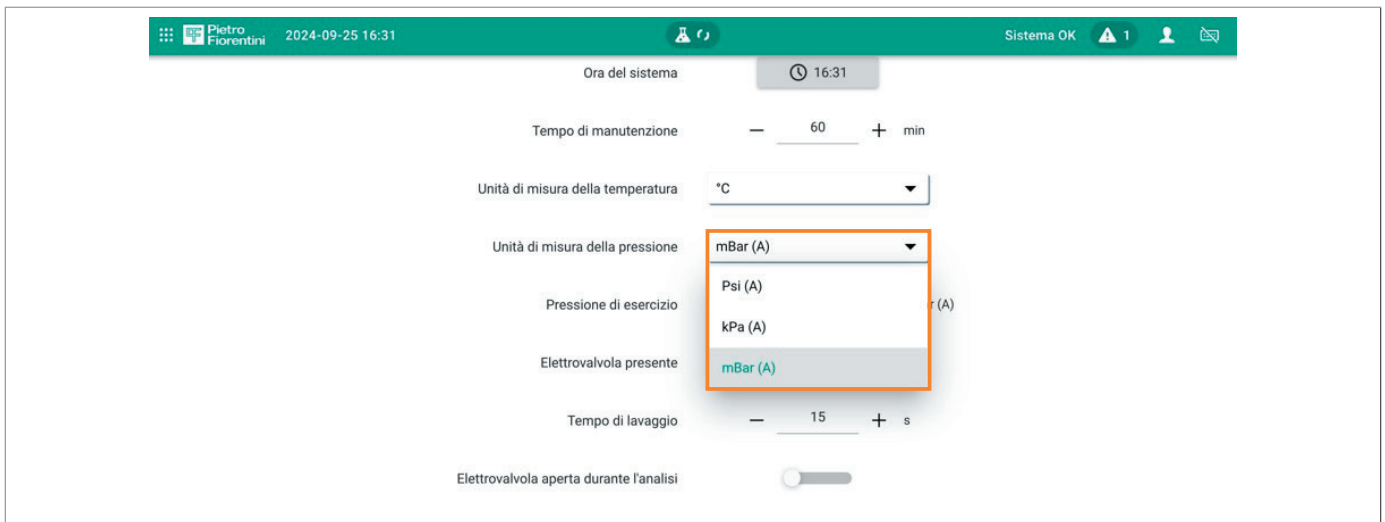

OPERATING PRESSURE

In this section you can configure the operating pressure of the gas in the analysis cell. This value depends on the pressure values present in each system, this value must be set using the pressure value defined in the “Information” section. During seasonal changes, it is important to check for any changes in pressure and update this data accordingly. This parameter is essential, because if the set value varies by more than $\pm 20\%$, the system will detect an anomaly. This data can be changed using the “-” or “+” keys.

It is possible to use this data to understand whether the pressure regulator upstream of the measuring cell may have failed and therefore the pressure has reached the value set on the PSV vent valve and venting to atmosphere is in progress.



SOLENOID VALVE PRESENT

In this section you can configure the operating pressure of the gas in the analysis cell. This value depends on the pressure values present in each system, this value must be set using the pressure value defined in the “Information” section. During seasonal changes, it is important to check for any changes in pressure and update this data accordingly. This parameter is essential, because if the set value varies by more than $\pm 20\%$, the system will detect an anomaly. This data can be changed using the “-” or “+” keys.

It is possible to use this data to understand whether the pressure regulator upstream of the measuring cell may have failed and therefore the pressure has reached the value set on the PSV vent valve and venting to atmosphere is in progress.

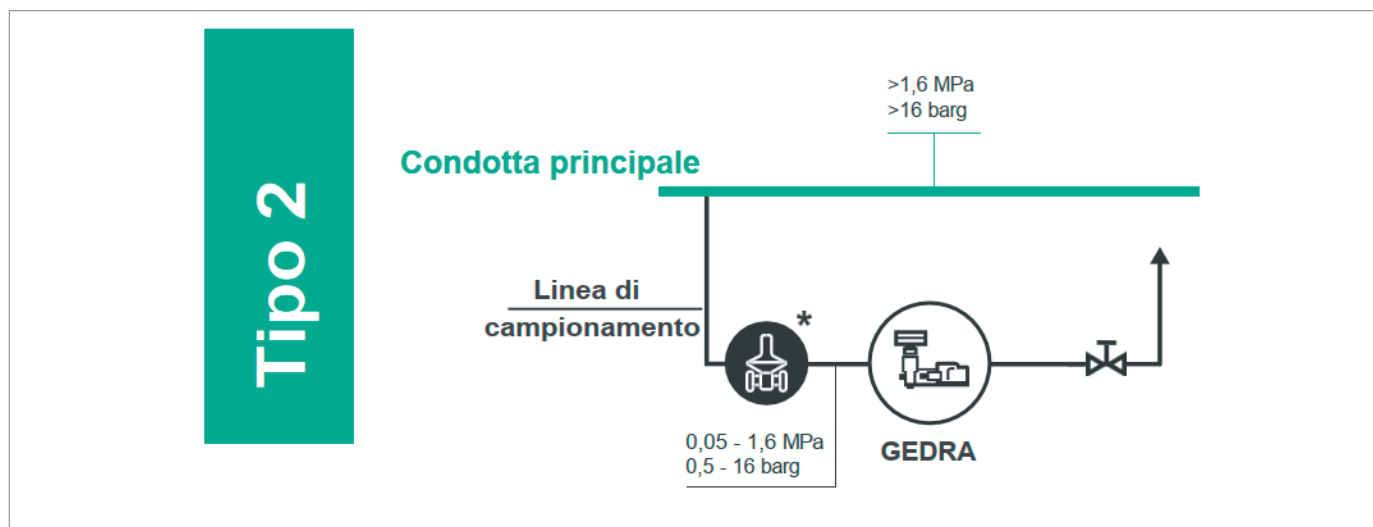



If the solenoid valve is not present, the “Flushing time” and “Solenoid valve open during analysis” cannot be modified.



FLUSHING TIME

In this section the solenoid valve flushing time is defined.

The value can be changed by using the “-” or “+” keys.

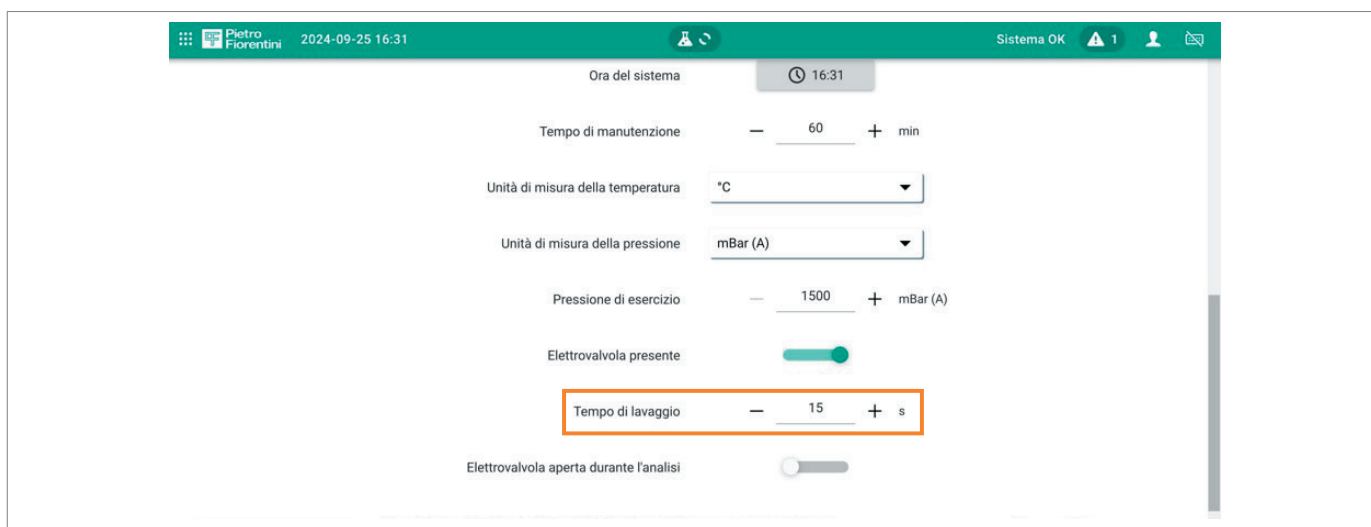

SOLENOID VALVE OPEN DURING ANALYSIS

In this section you determine whether to leave the solenoid valve open or closed during the analysis. Keep the solenoid valve open

allows you to monitor a gas transient, allowing calculations based on the average conditions of the gas flowing during the analysis. Conversely, if the solenoid valve remains closed, the analysis will be conducted using the gas present before the process began. Opening the solenoid valve is recommended in case of frequent gas fluctuations.



5.5.1.2 - ANALYSIS

In the settings section, you can access the analysis settings area by clicking on the "Analysis" item from the top menu. The following screen will appear, where you can perform the following actions:

- Select the unit of measurement for the higher calorific value;
 - Change the reference temperatures (T1 and T2); T1 and T2 are respectively the combustion temperature (temperature at which a fuel starts to burn) and the volume measurement temperature (temperature at which the volume of the fuel is measured), defined according to UNI EN 6976.
 - Change the analysis interval (in seconds): identifies the period of time between one analysis and the next
 - Change the verification validity period (in days): identifies the number of days of validity of the metrological verification
- Once you have made your changes, confirm them with the "Save" button or cancel the operation with the "Cancel" button.

HCV UNIT OF MEASUREMENT

In this section you can change the unit of measurement of the Higher Calorific Value (HCV).

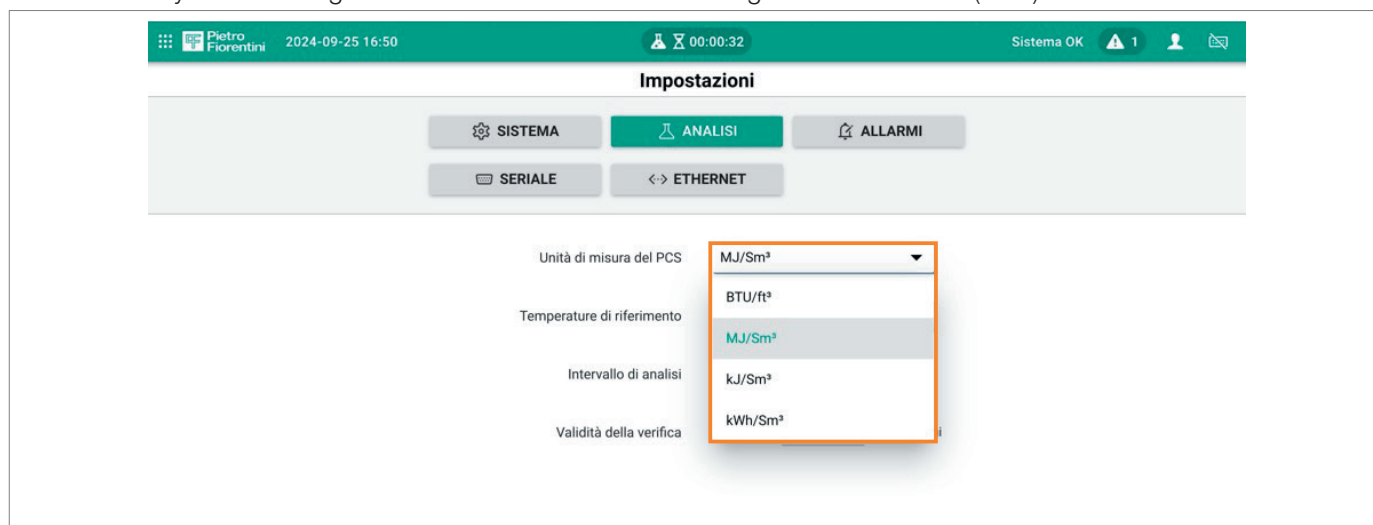

REFERENCE TEMPERATURE

In this section you can change the reference temperatures T1 and T2.

T1 and T2 are respectively the combustion temperature (temperature at which a fuel starts to burn) and the volume measurement temperature (temperature at which the volume of the fuel is measured), defined according to UNI EN 6976.

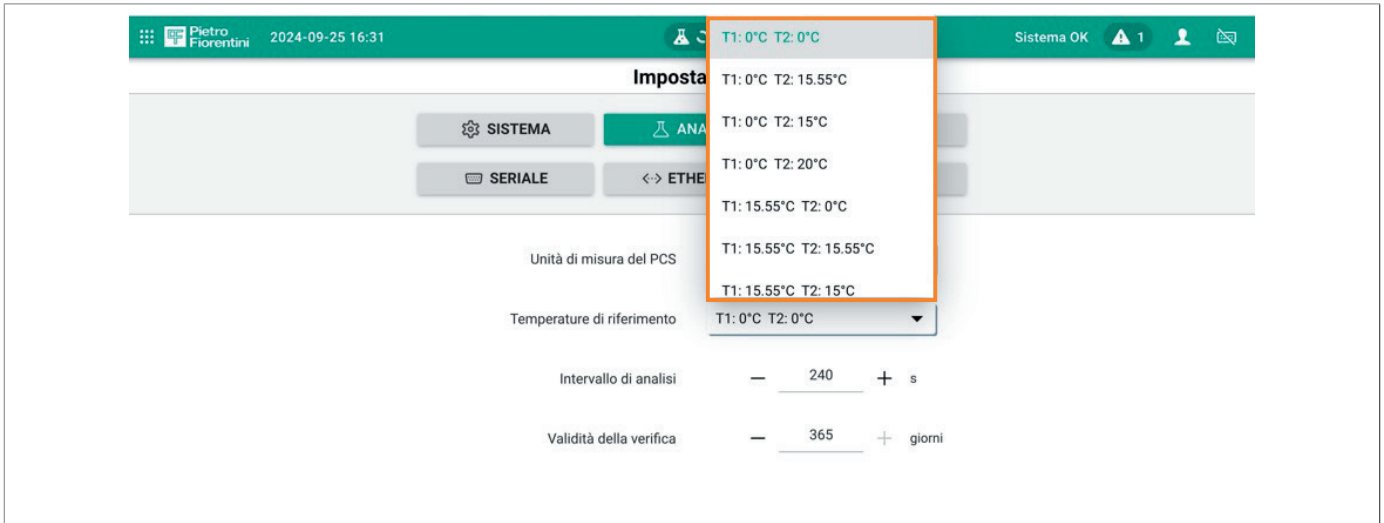

The screenshot shows the 'Impostazioni' (Settings) page in the Pietro Fiorentini web interface. The 'Temperature di riferimento' (Reference temperature) dropdown menu is open, displaying several options for T1 and T2. The current selection is T1: 0°C T2: 0°C. Other options include T1: 0°C T2: 15.55°C, T1: 0°C T2: 15°C, T1: 0°C T2: 20°C, T1: 15.55°C T2: 0°C, T1: 15.55°C T2: 15.55°C, and T1: 15.55°C T2: 15°C. The 'Intervallo di analisi' (Analysis interval) is set to 240 s, and 'Validità della verifica' (Verification validity) is set to 365 giorni.

ANALYSIS INTERVAL

In this section you can change the analysis interval (identifies the period of time between one analysis and the next) using the “-” or “+” keys.



The screenshot shows the 'Impostazioni' (Settings) page in the Pietro Fiorentini web interface. The 'Intervallo di analisi' (Analysis interval) is highlighted with a red box, showing the value 240 s. The 'Validità della verifica' (Verification validity) is set to 365 giorni.

VALIDITY OF VERIFICATION

In this section it is possible to modify the validity of the verification (identifies the number of days of validity of the metrological verification) using the “-” or “+” keys. The validity of frequency is in accordance with what is indicated in the OIML R140 metrological certificate.

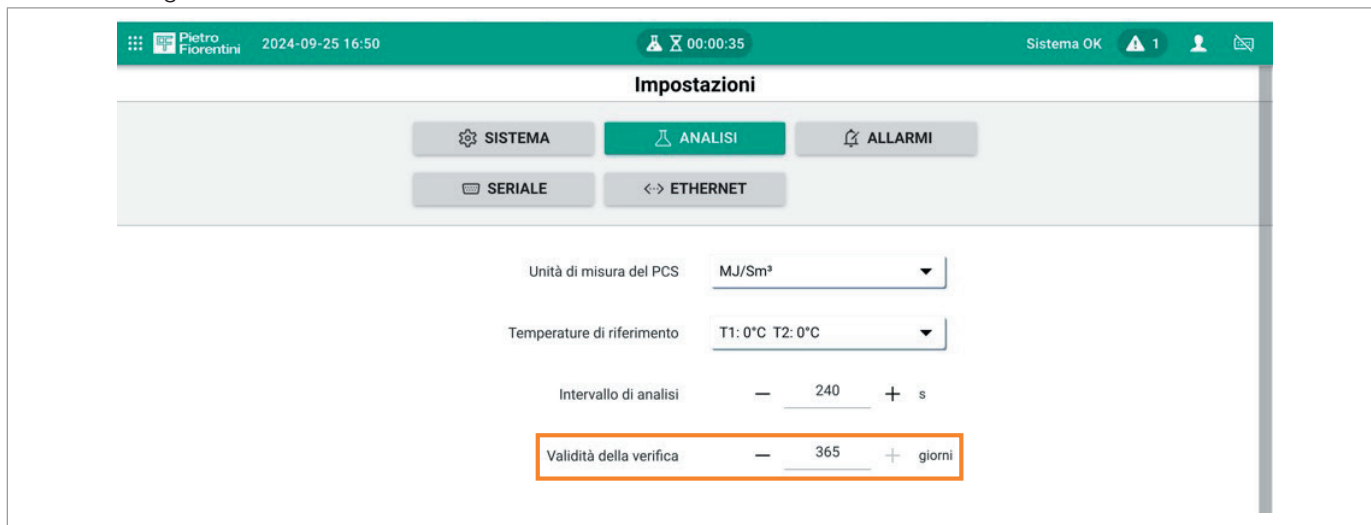

5.5.1.3 - ALARMS

In the settings section you can access the alarm settings menu by clicking on the “alarms” item. To make changes in this section you need to activate maintenance mode

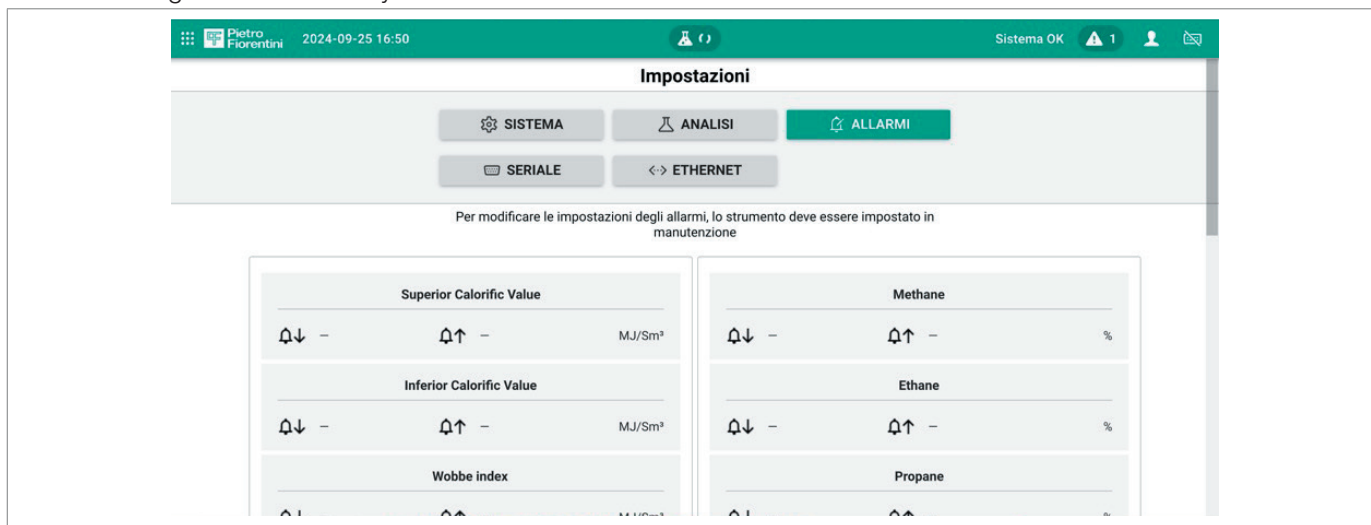

For each of the items listed, you can change the maximum and minimum ranges by setting the maintenance mode. To activate maintenance mode, click the “dotted square” next to the Pietro Fiorentini logo, then select “SETTINGS” from the drop-down menu. In the “SYSTEM” section, activate maintenance mode.

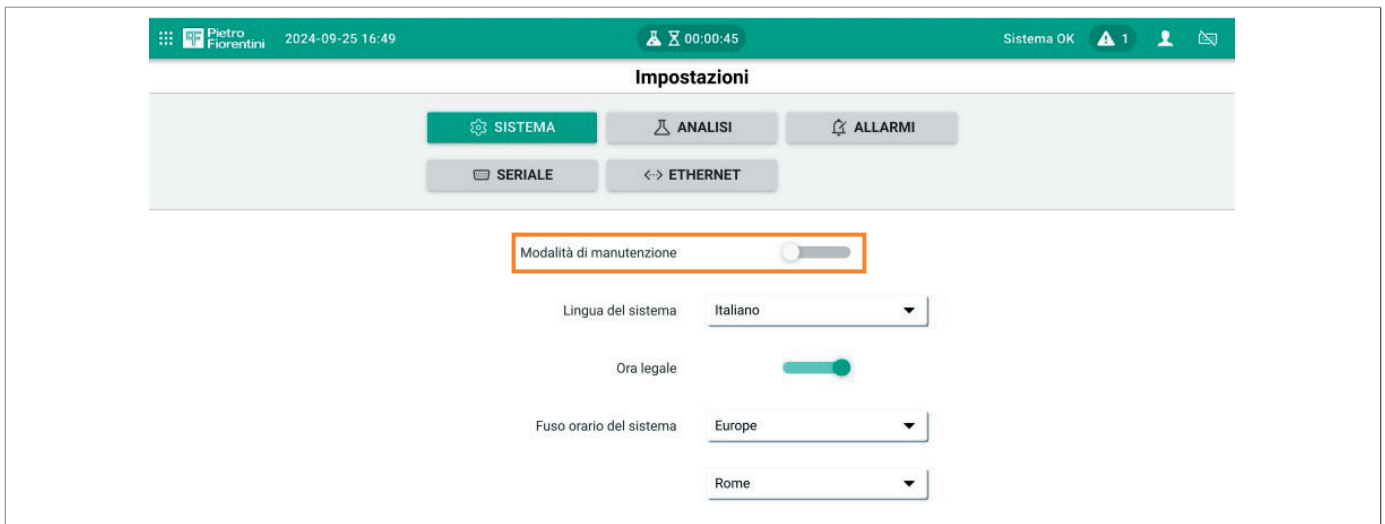
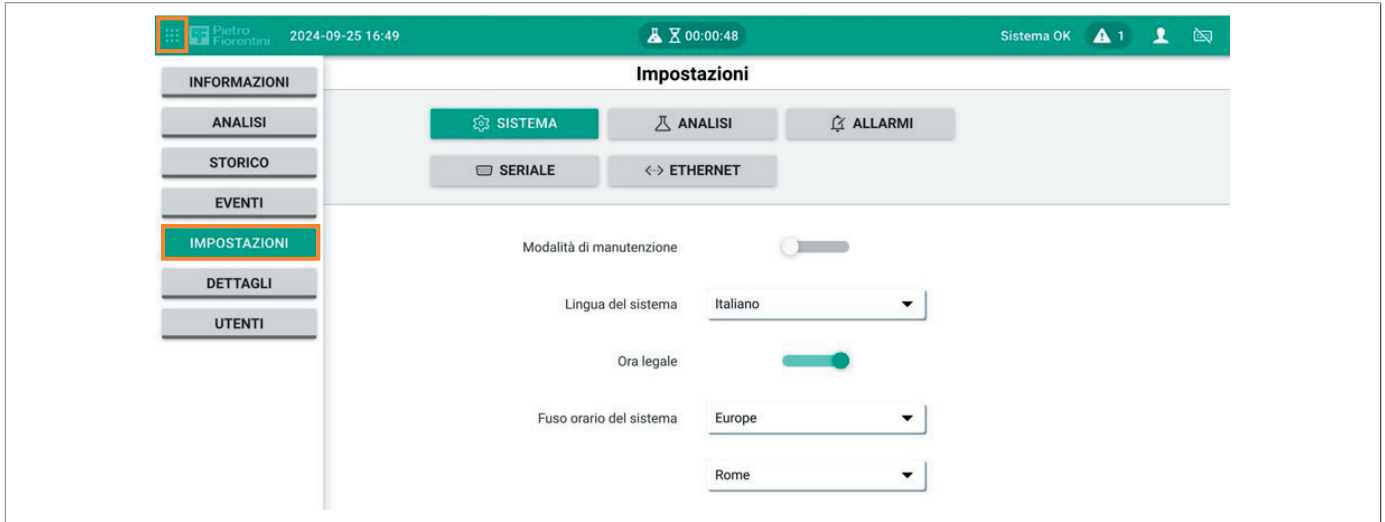

There is a maximum activation time in maintenance mode. Once this predefined time interval has elapsed, the system will automatically disable maintenance mode, restoring normal operation without the need for manual intervention. Alternatively, if the maintenance operation is completed before this activation time, manually disable and click “maintenance mode” again.

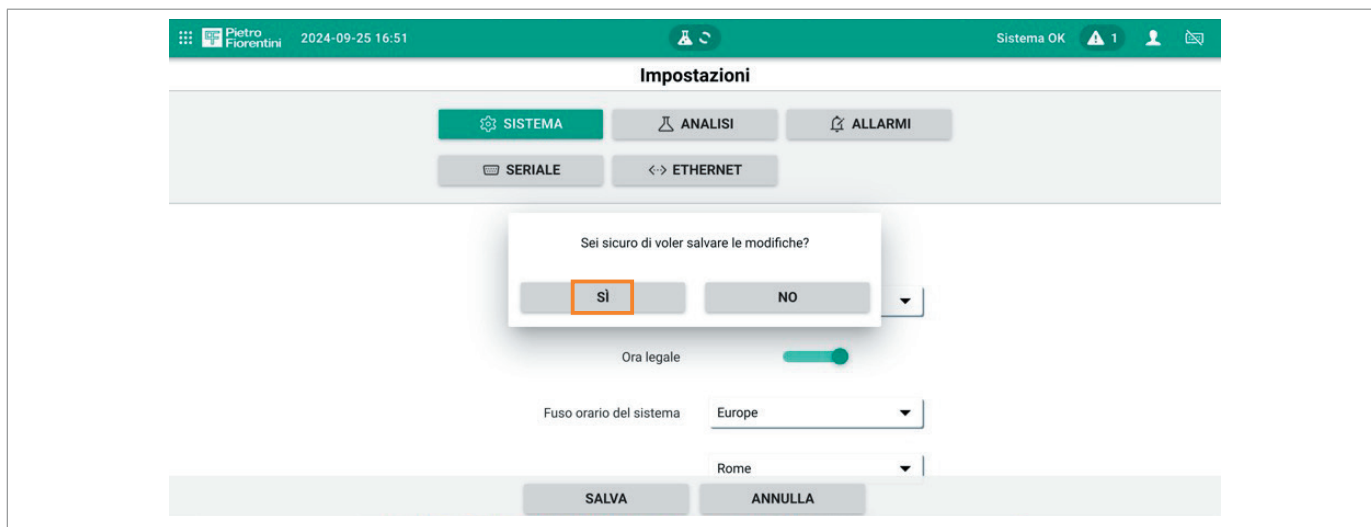

After saving the changes, the central bar changes colour from green to yellow, indicating that maintenance mode is activated. The bar also shows the time remaining in this mode.

Once the indicated period has expired, the system will automatically return to normal operating mode.

This allows users to easily monitor the maintenance duration and ensures that the GEDRA resumes its regular operation without further intervention.

To change the alarm limit values, click the edit icon.

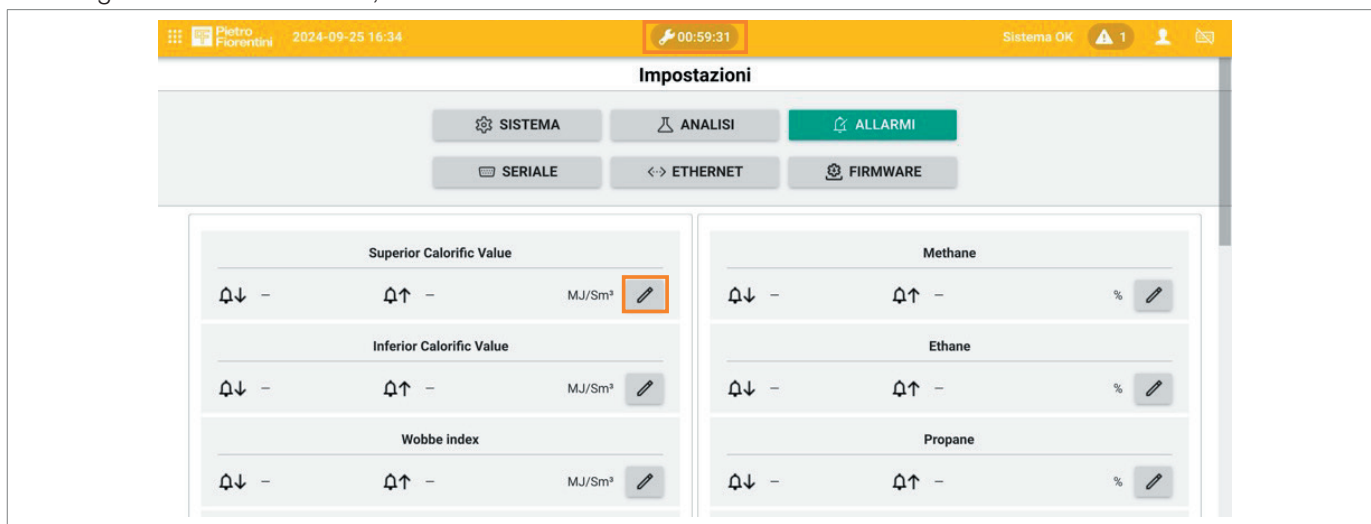

Then click the empty cell corresponding to the parameter you want to change and enter the new value you want to change. Then click “APPLY”, otherwise press “CANCEL”.

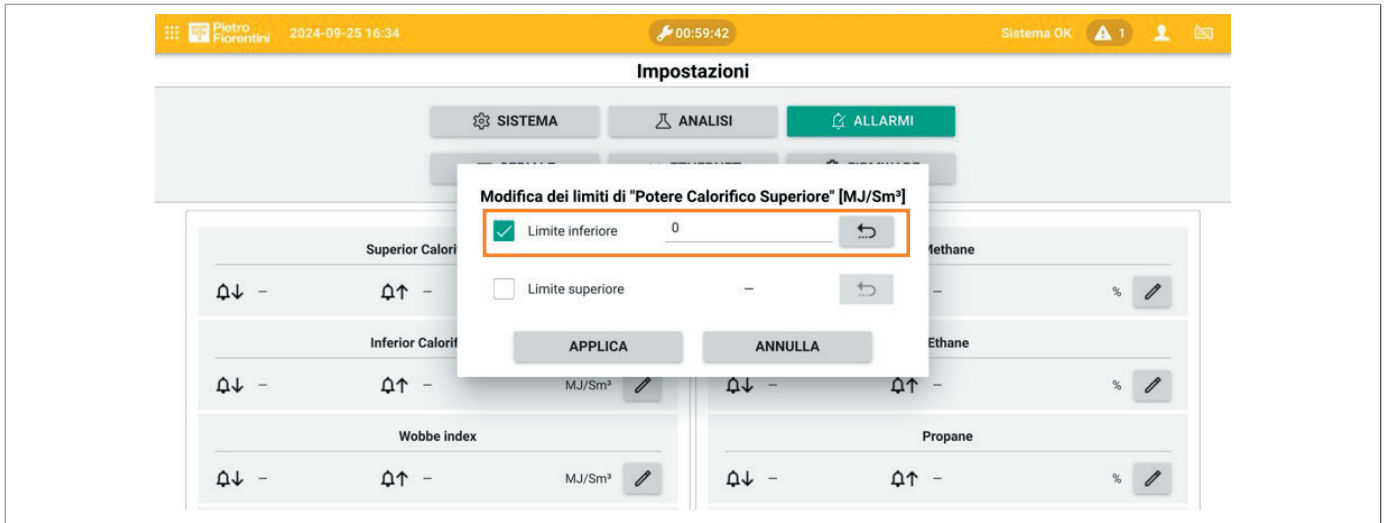

The same actions will have to be carried out for the other parameters.

5.5.1.4 - SERIAL

In the settings section you can access the “Serial” menu to set the characteristics of the individual ports. For each of the ports you can:

- Activate or deactivate the port itself;
- Set the transmission speed;
- Indicate the type of “protocol”;
- Indicate whether the port is connected to the “Flowcomputer” or not;

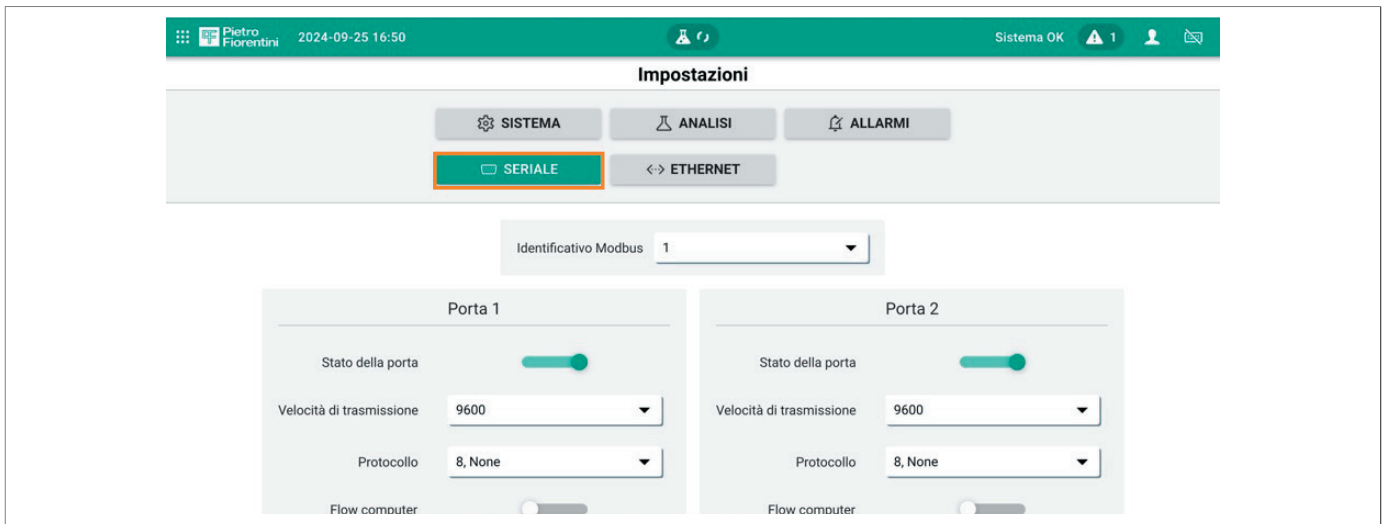

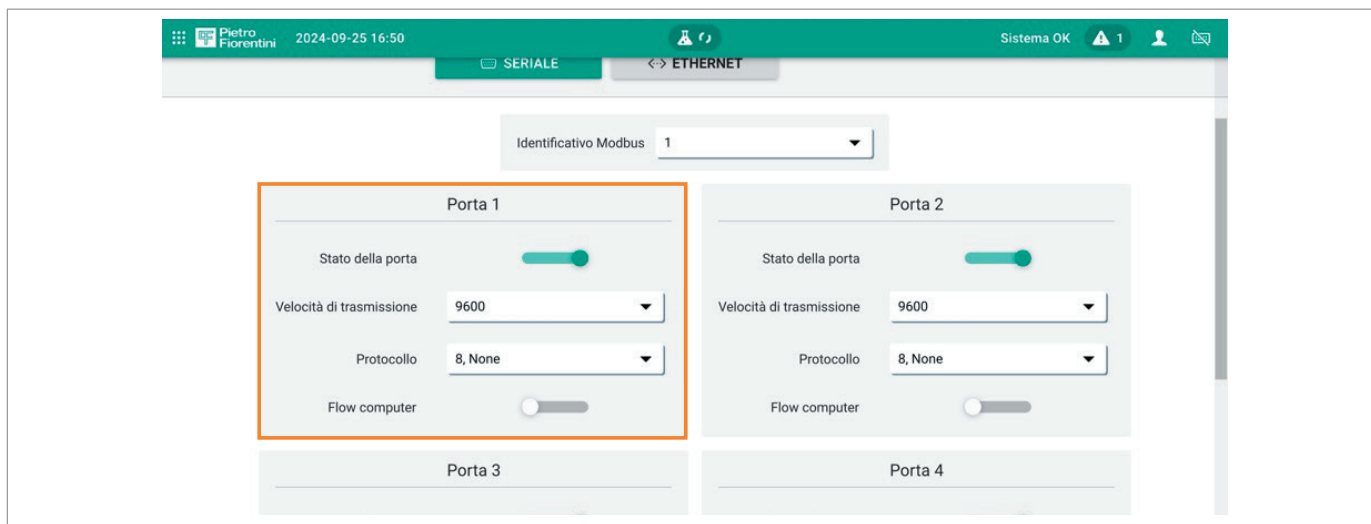

The following are the connections to be made between the ports present in the safe area and those present in the hazardous area in the Ex-d enclosure of the analysis module:

- Port 1 will need to be connected to port J6 on the MB-001 board
- Port 2 will need to be connected to port J9 on the MB-001 board
- Port 3 will need to be connected to port J11 on the MB-001 board
- Port 4 will need to be connected to port J12 on the MB-001 board

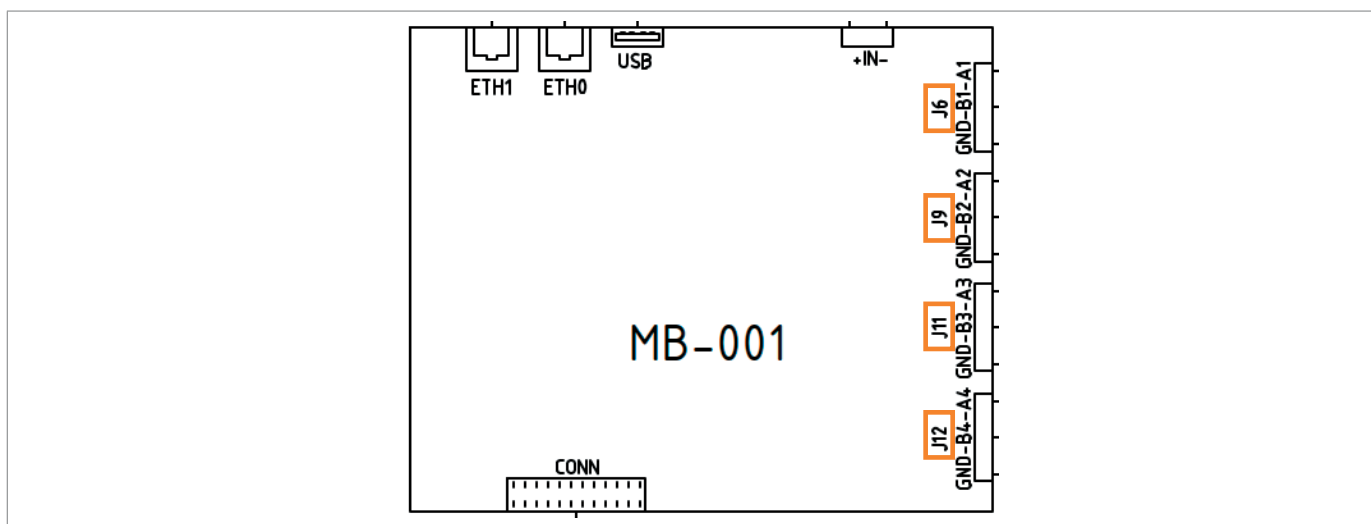

5.5.1.5 - ETHERNET

In the settings section, by selecting the “ETHERNET” option in the menu, you can access the port configuration and modify the data for each port.

Address: MAC (Media Access Control) address, a unique identifier assigned to each networked device

Prefix length: number of bits that make up the network part of an IP address

Gateway: access point that allows communication between two different networks



5.5.2 - USERS

To access the “USERS” section and view/edit the profiles available for access, click the “dotted square” icon located next to the Pietro Fiorentini logo, and select “USERS”. The maintenance technician has the ability to modify and/or delete user profiles.

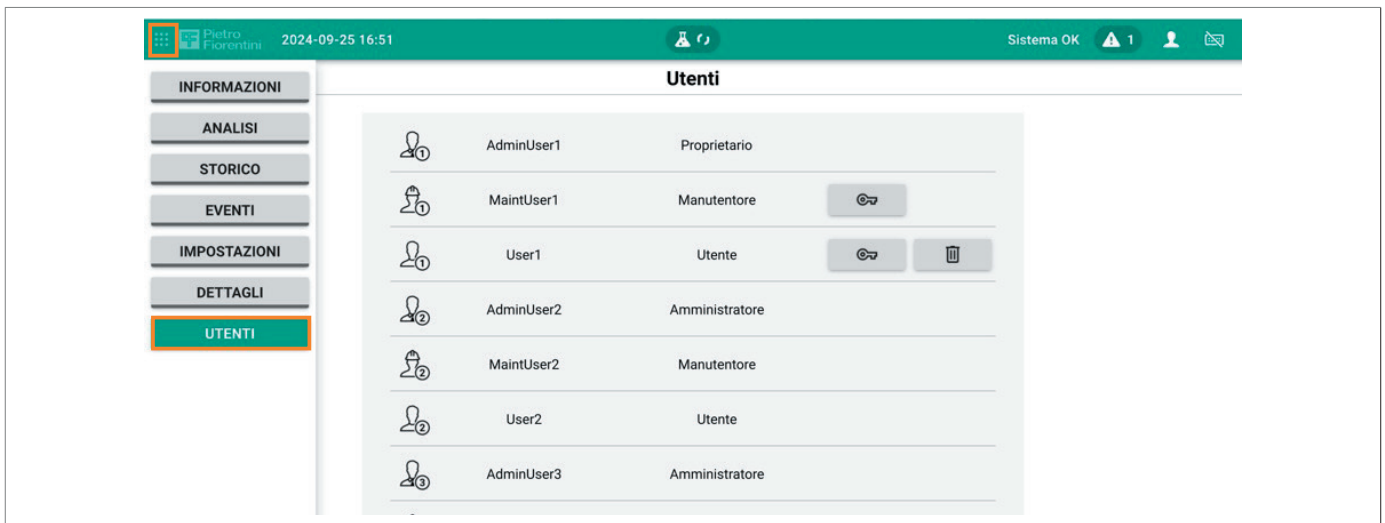

Use this section to:

1. View the accounts that can access the device;

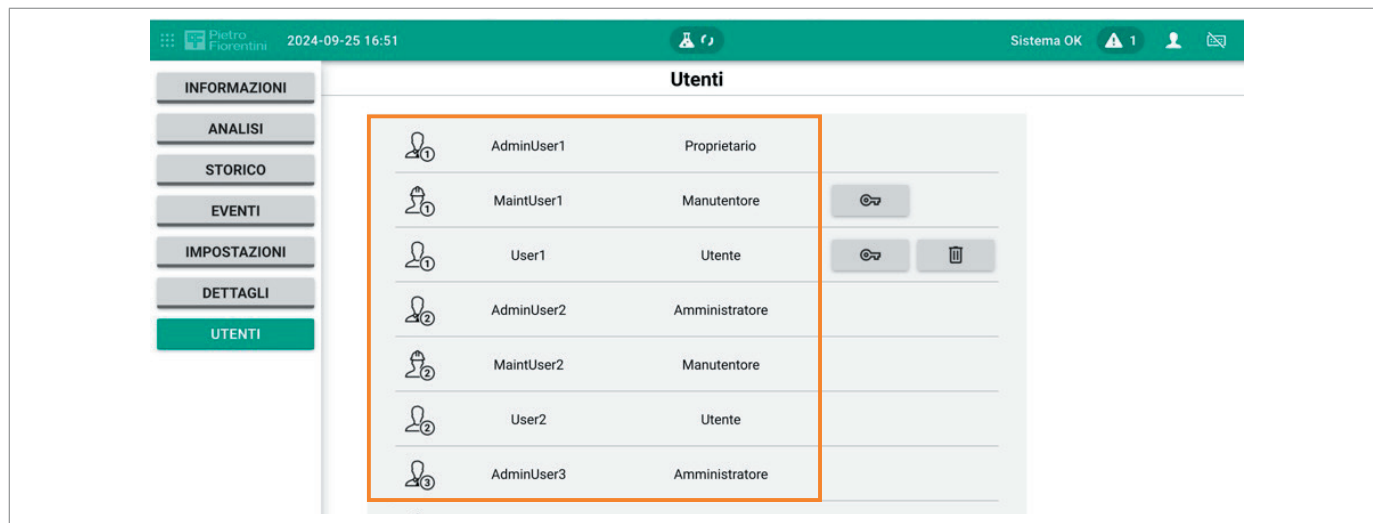

2. Change your password by clicking the key symbol: to do this, you need to enter your old password, type your new password twice, and then click Save;

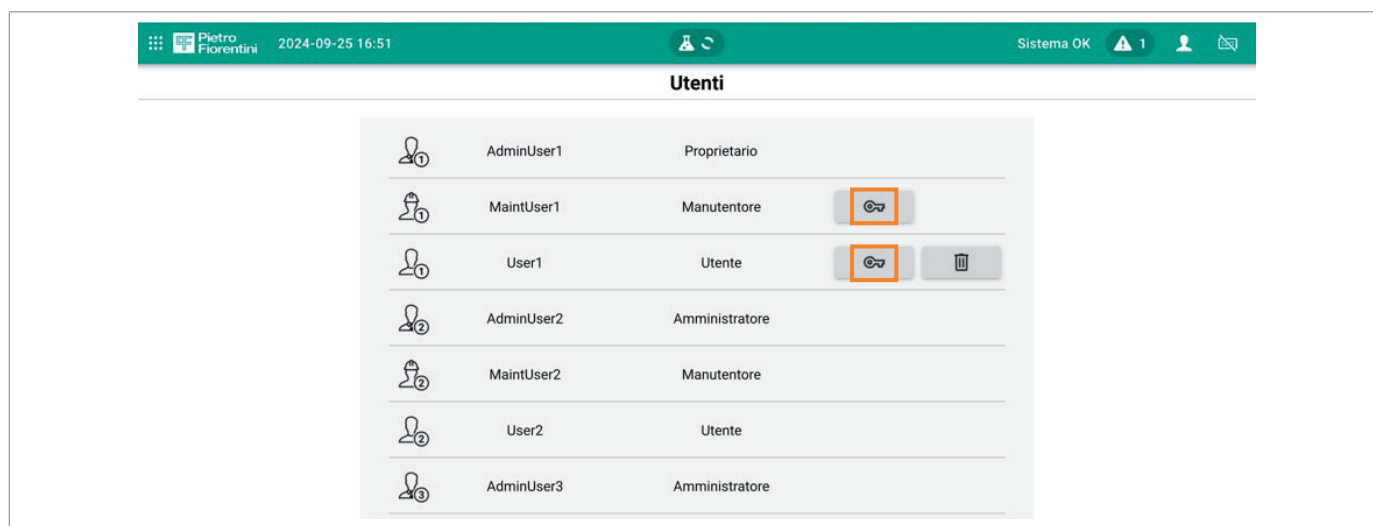

3. To cancel the operations click on "Cancel". Delete your "user" profile account by clicking the trash can symbol

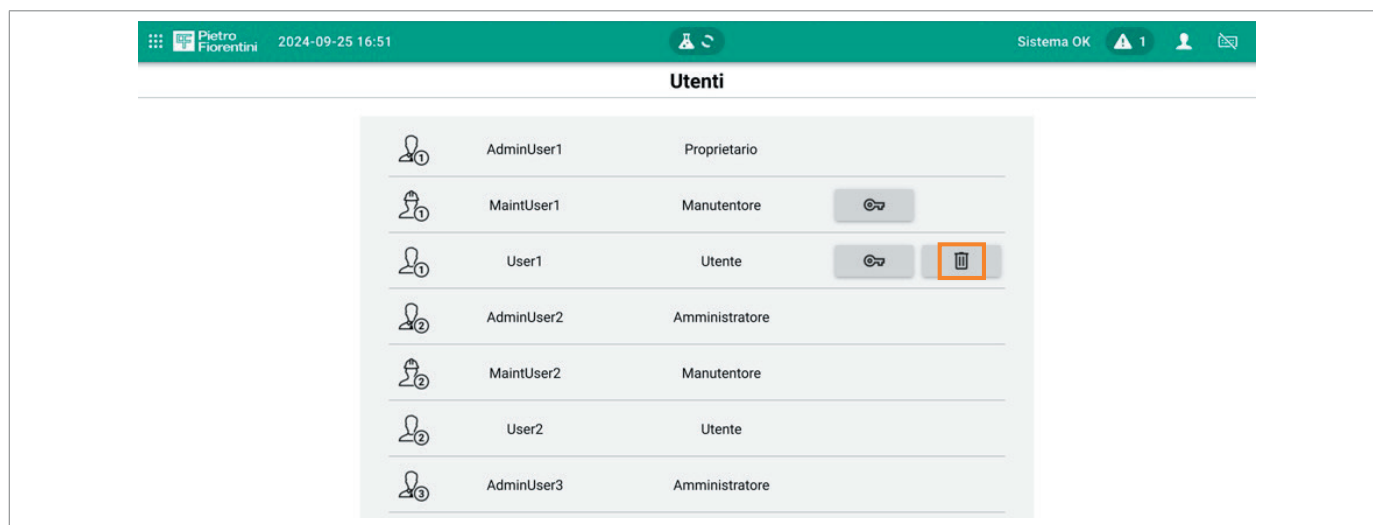

4. Add an additional account using the “+” button at the bottom of the table.

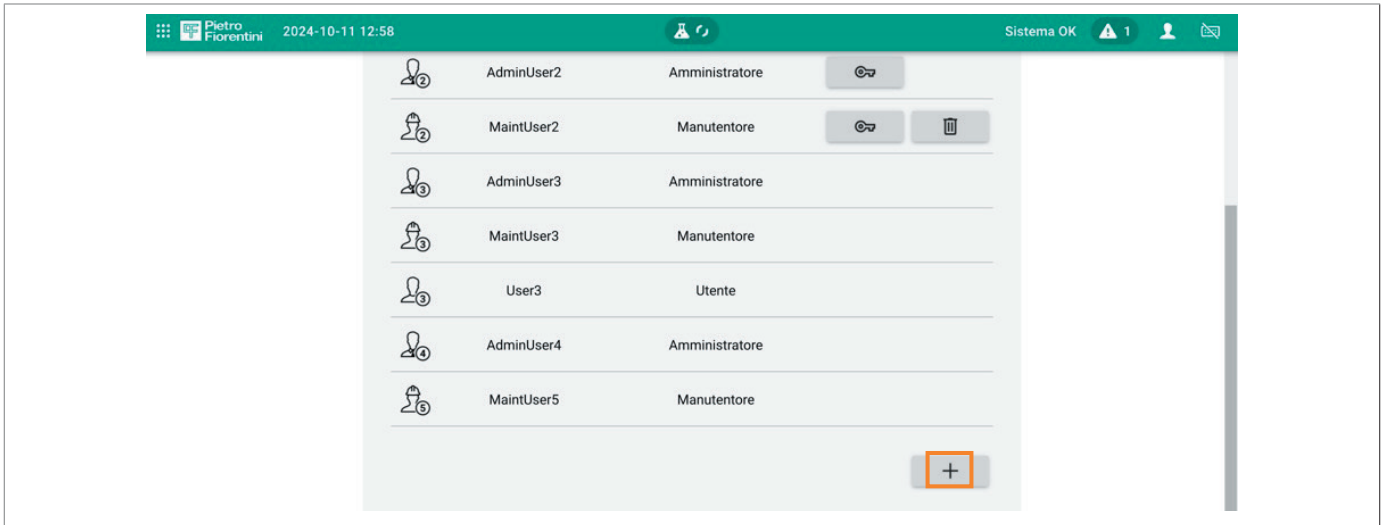

5.5.3 - PERIODIC VERIFICATION

Periodic verification is required in the case of fiscal applications, where OIML R140 metrological certification is required, otherwise this operation is not foreseen.

The operational details for the periodic verification are given in chapter 9, while this chapter instead contains the details relating to the operations to be performed in the user interface.

To perform the periodic verification, you need to set the maintenance mode by accessing “SETTINGS” and selecting “Maintenance mode”.



Then click the “dotted square” icon located next to the Pietro Fiorentini logo and the “VERIFICATION” button.



The following parameters can be changed in the Periodic verification settings section:

- **Number of cylinders** (change the number by clicking the “+”; “-” buttons): a certified sample gas cylinder is required to carry out the check.
- **Number of discarded analyses:** in compliance with the UNI 9167 adjustment, it is necessary to exclude the first three analyses carried out. Once the number of analyses to be discarded has been selected, GEDRA will perform the operation automatically.
- **Number of analyses for verification:** in compliance with the UNI 9167 regulation, it is necessary to carry out a minimum of 10 consecutive analyses
- **Analysis interval:** no limit is indicated in terms of analysis range in the UNI 9167 standard



Before proceeding with the periodic verification by clicking “VERIFICATION”, it is possible to carry out a single analysis with cylinder gas, which defines the gas properties defined as output by the GEDRA system (higher calorific value, Wobbe index, gas composition, etc.). When the verification is carried out, whether single or periodic, the database records that the injected gas is not accounted for as it is not network gas.

To start the single verification, click the “SINGLE” button and then “START”.

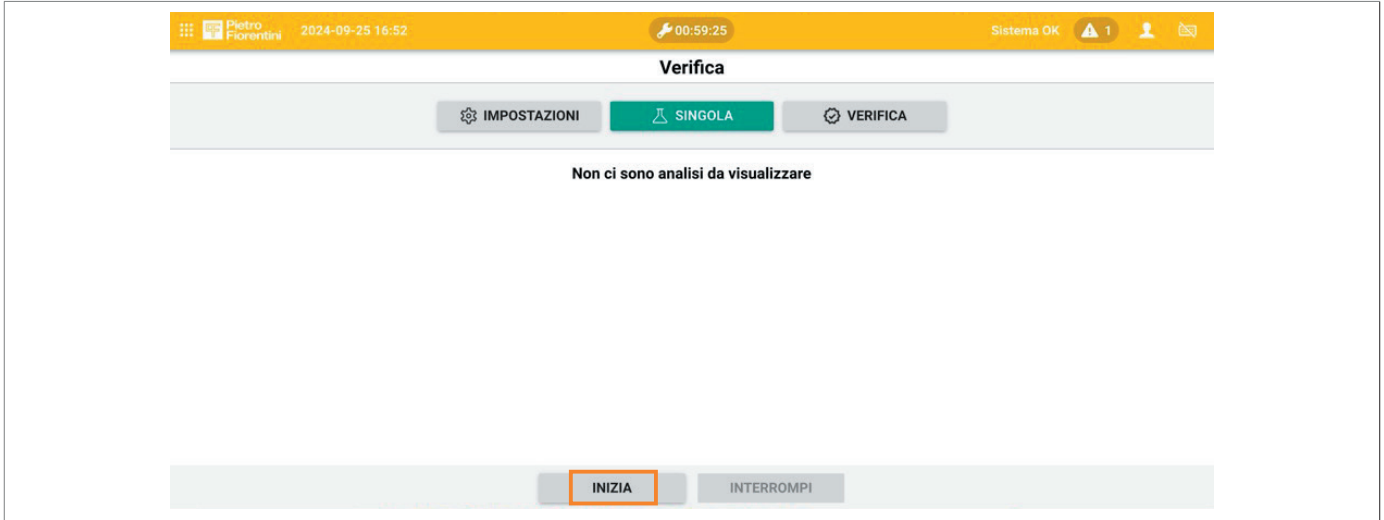

To proceed with the verification operation, click “YES” to the question “Are you sure you want to start a single analysis?”, otherwise click “NO”.



If you need to stop the verification, click “STOP”. After performing this action, the error “Acquiring a single analysis” appears.

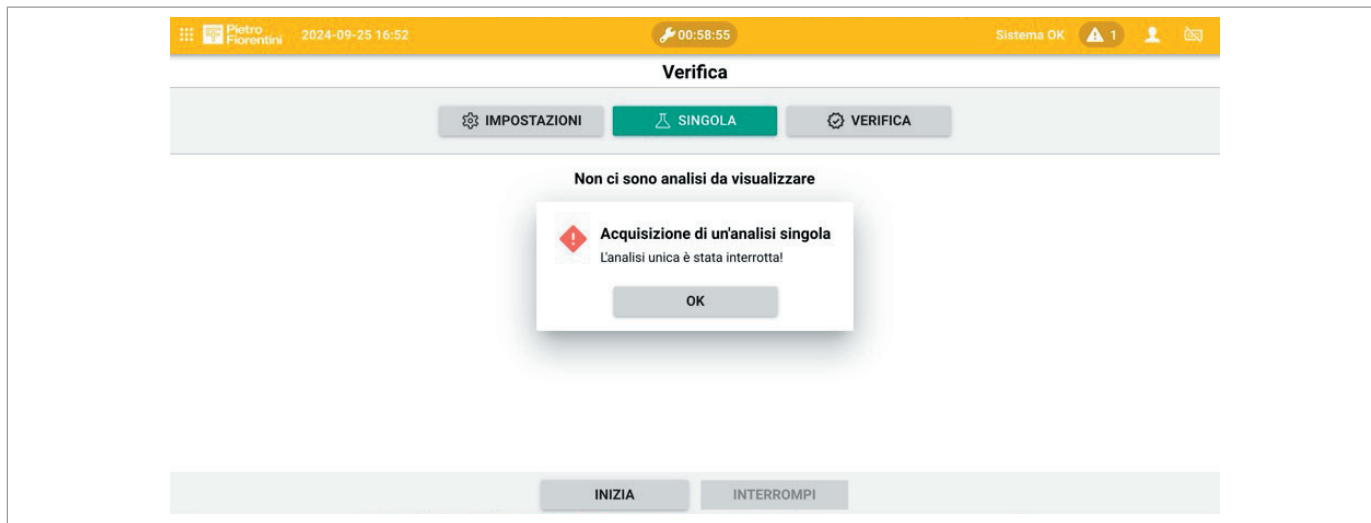

If the SINGLE check is completed, a screen will be visible with the data obtained under the operating conditions indicated at the top right. The time and date the analysis was performed are shown on the left side of the table.

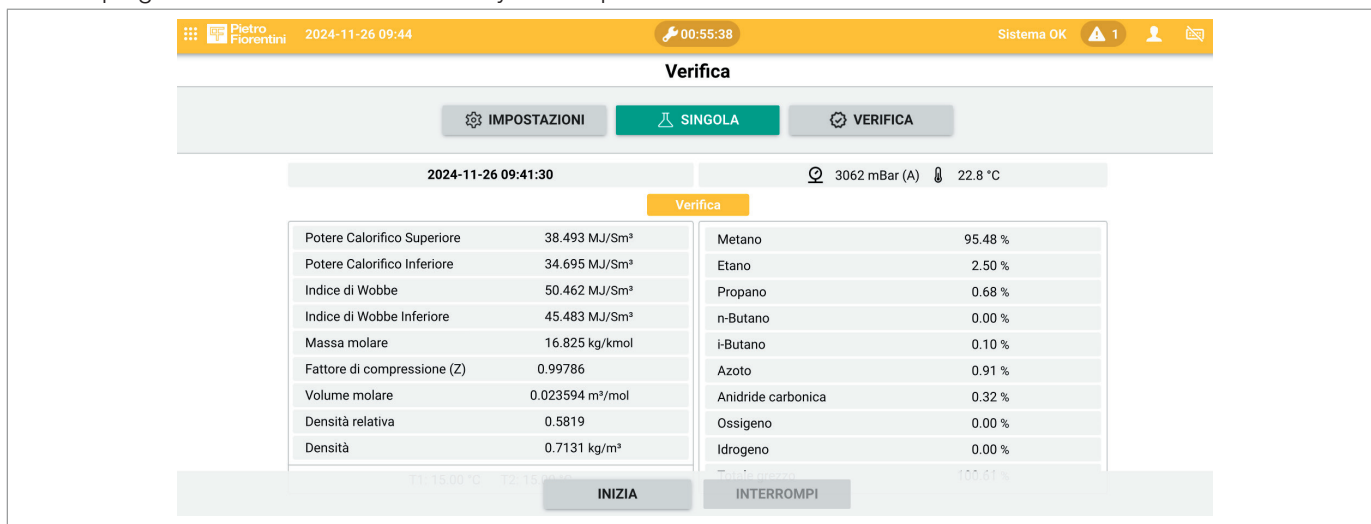

To start the periodic verification of the GEDRA, click “VERIFICATION”.

Before clicking “START”, connect the certified gas cylinder and wait for the instrument to flush.



Once you click “START” you will be asked to confirm that you want to perform the verification according to the parameters selected in “SETTINGS”. To start the verification, click “YES”, otherwise to cancel the request click “NO”.



Once the periodic verification has been started, the screen will indicate “acquisition of the analysis to be discarded”, and the number of analyses indicated in the “SETTINGS” section of the Verification will be discarded.

To stop the activity click “INTERRUPT”.



After clicking “INTERRUPT”, you will be asked to confirm whether you want to stop the verification. Select “YES” if you want to stop the verification, otherwise “NO”.

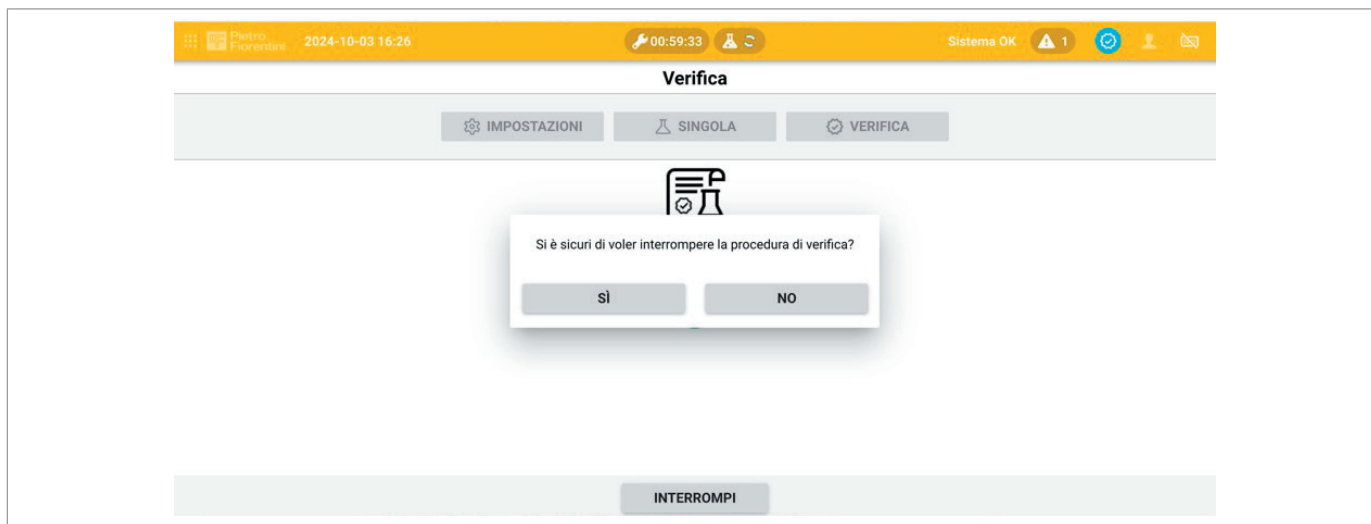

Once the analyses have been discarded, the verification will proceed.



The analysis values obtained during the test will then be visible.

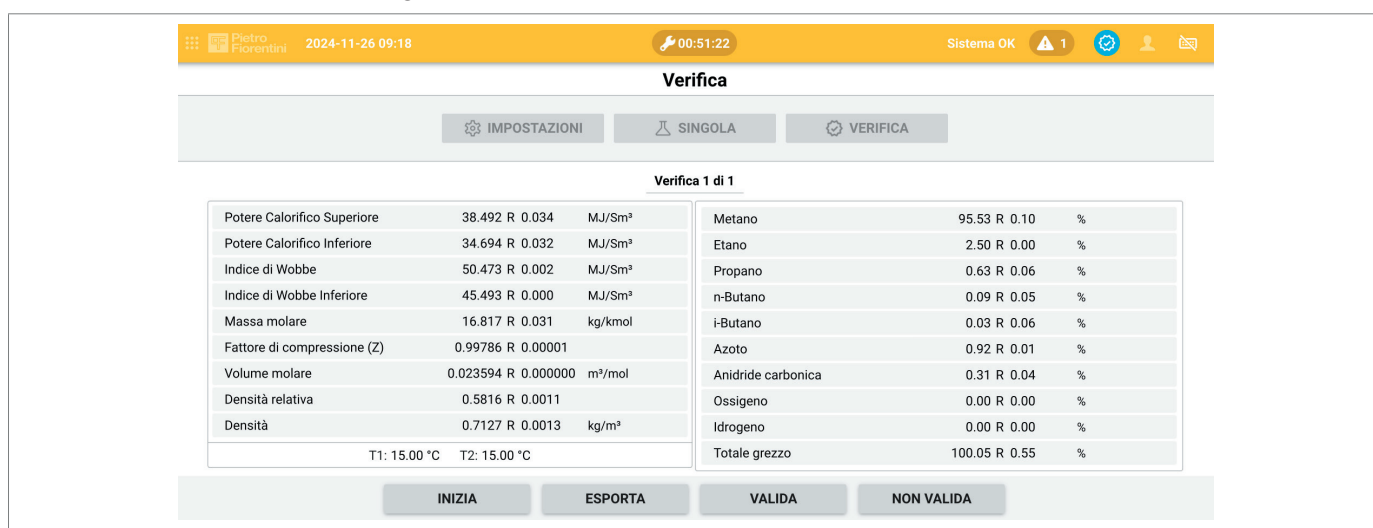

The bottom of the screen shows the rejected analyses, the number of analyses to be verified and the analysis interval. This data is the one selected in the first screen of the verification section (under Settings).





Verifica

IMPOSTAZIONI SINGOLA VERIFICA

Indice di Wobbe	50.473 R 0.002	MJ/Sm ³	etano	2.00 R 0.00	%
Indice di Wobbe Inferiore	45.493 R 0.000	MJ/Sm ³	Propano	0.63 R 0.06	%
Massa molare	16.817 R 0.031	kg/kmol	n-Butano	0.09 R 0.05	%
Fattore di compressione (Z)	0.99786 R 0.00001		i-Butano	0.03 R 0.06	%
Volume molare	0.023594 R 0.000000	m ³ /mol	Azoto	0.92 R 0.01	%
Densità relativa	0.5816 R 0.0011		Anidride carbonica	0.31 R 0.04	%
Densità	0.7127 R 0.0013	kg/m ³	Ossigeno	0.00 R 0.00	%
			Idrogeno	0.00 R 0.00	%
			Totale grezzo	100.05 R 0.55	%

T1: 15.00 °C T2: 15.00 °C

Analisi scartate 1
 Numero di analisi per la verifica 2
 Intervallo di analisi 110 s

INIZIA **ESPORTA** VALIDA NON VALIDA

You will then be asked to confirm the cylinder verification validation. If yes, press YES, otherwise press NO and repeat the check by clicking START.



Verifica

IMPOSTAZIONI SINGOLA VERIFICA

Indice di Wobbe	50.473 R 0.002	MJ/Sm ³	etano	2.00 R 0.00	%
Indice di Wobbe Inferiore	45.493 R 0.000	MJ/Sm ³	Propano	0.63 R 0.06	%
Massa molare	16.817		n-Butano	0.09 R 0.05	%
Fattore di compressione (Z)	0.99786		i-Butano	0.03 R 0.06	%
Volume molare	0.023594		Azoto	0.92 R 0.01	%
Densità relativa	0.5816		Anidride carbonica	0.31 R 0.04	%
Densità	0.7127 R 0.0013	kg/m ³	Ossigeno	0.00 R 0.00	%
			Idrogeno	0.00 R 0.00	%
			Totale grezzo	100.05 R 0.55	%

T1: 15.00 °C T2: 15.00 °C

Analisi scartate 1
 Numero di analisi per la verifica 2
 Intervallo di analisi 110 s

INIZIA **ESPORTA** VALIDA NON VALIDA

Si è sicuri di voler validare la verifica della bombola 1 di 1?

SÌ NO

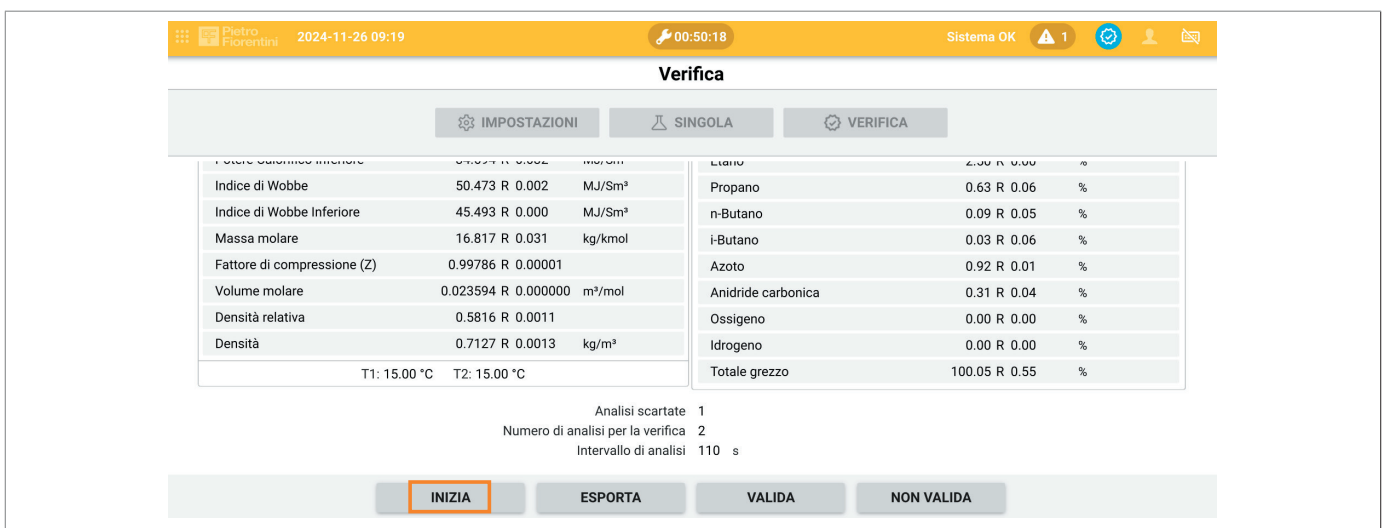

Verifica

IMPOSTAZIONI SINGOLA VERIFICA

Indice di Wobbe	50.473 R 0.002	MJ/Sm ³	etano	2.00 R 0.00	%
Indice di Wobbe Inferiore	45.493 R 0.000	MJ/Sm ³	Propano	0.63 R 0.06	%
Massa molare	16.817 R 0.031	kg/kmol	n-Butano	0.09 R 0.05	%
Fattore di compressione (Z)	0.99786 R 0.00001		i-Butano	0.03 R 0.06	%
Volume molare	0.023594 R 0.000000	m ³ /mol	Azoto	0.92 R 0.01	%
Densità relativa	0.5816 R 0.0011		Anidride carbonica	0.31 R 0.04	%
Densità	0.7127 R 0.0013	kg/m ³	Ossigeno	0.00 R 0.00	%
			Idrogeno	0.00 R 0.00	%
			Totale grezzo	100.05 R 0.55	%

T1: 15.00 °C T2: 15.00 °C

Analisi scartate 1
 Numero di analisi per la verifica 2
 Intervallo di analisi 110 s

INIZIA ESPORTA VALIDA NON VALIDA

If “INVALID” verification is selected, you are asked to confirm the verification is invalid. Once the verification is confirmed as invalid, the system will generate a Critical Metrological Error message, indicating that the periodic verification has failed. In the event of a critical error, the GEDRA system immediately stops the analysis. This will be visible on the “Info” screen, where it will be marked as “Invalid Analysis”.



The screenshot shows the 'Verifica' (Verification) screen of the GEDRA system. At the top, there is a status bar with the date '2024-11-26 09:21', time '00:48:44', and system status 'Sistema OK' with a warning icon and the number '1'. Below the status bar, the title 'Verifica' is centered. There are three tabs: 'IMPOSTAZIONI', 'SINGOLA', and 'VERIFICA'. The 'VERIFICA' tab is active. The main area displays a table of verification parameters:

Indice di Wobbe	50.473 R 0.002	MJ/Sm ³	Etano	2.30 R 0.00	%
Indice di Wobbe l	15.168 R 0.000	MJ/Sm ³	Propano	0.63 R 0.06	%
Massa molare					%
Fattore di compressione					%
Volume molare					%
Densità relativa					%
Densità	0.7127 R 0.0013	kg/m ³	Idrogeno	0.00 R 0.00	%
	T1: 15.00 °C T2: 15.00 °C		Totale grezzo	100.05 R 0.55	%

A confirmation dialog box is overlaid on the table, asking: "Si è sicuri di voler invalidare la verifica della bombola 1 di 1? Al termine della procedura di verifica, il sistema verrà impostato automaticamente nello stato di 'Errore critico'." (Are you sure you want to invalidate the verification of cylinder 1 of 1? At the end of the verification procedure, the system will be automatically set to the state of 'Critical Error'). The dialog has two buttons: 'Sì' (Yes) and 'NO'.

Below the table, the following information is displayed:

- Analisi scartate: 1
- Numero di analisi per la verifica: 2
- Intervallo di analisi: 110 s

At the bottom of the screen, there are four buttons: 'INIZIA', 'ESPORTA', 'VALIDA', and 'NON VALIDA'.

5.6 - ADMINISTRATOR PROFILE

The Administrator profile, in addition to all the functions seen for the user and maintenance technician profiles, can also perform the following activities:

- Edit and/or create “Maintenance” and “User” profiles
- Edit and update metrology files (firmware)
- View analysis details
- Reset events

5.6.1 - ANALYSIS READING

In the Administrator profile, in addition to what is indicated in the user profile, it is possible to have further information by clicking “DETAILS”.



The screenshot shows the Administrator profile interface. The top bar displays the date and time (2024-11-25 15:48), system status (Sistema OK), and a notification icon (1). The main content area is titled 'Analisi' and shows a date and time (2024-11-25 15:46:40) and pressure/temperature (3089 mBar (A) 25.0 °C). A left sidebar contains a menu with the following items: INFORMAZIONI, ANALISI (highlighted), STORICO, EVENTI, IMPOSTAZIONI, DETTAGLI, and UTENTI. The main content area displays a table of analysis data:

2024-11-25 15:46:40		3089 mBar (A) 25.0 °C	
Potere Calorifico Superiore	10.70 kWh/Sm ³	Metano	95.53 %
Potere Calorifico Inferiore	9.64 kWh/Sm ³	Etano	2.52 %
Indice di Wobbe	14.03 kWh/Sm ³	Propano	0.67 %
Indice di Wobbe Inferiore	12.64 kWh/Sm ³	n-Butano	0.00 %
Massa molare	16.819 kg/kmol	i-Butano	0.10 %
Fattore di compressione (Z)	0.99786	Azoto	0.87 %
Volume molare	0.023594 m ³ /mol	Anidride carbonica	0.32 %
Densità relativa	0.5817	Ossigeno	0.00 %
Densità	0.7128 kg/m ³	Idrogeno	0.00 %
T1: 15.00 °C T2: 15.00 °C		Totale grezzo	101.48 %

A 'DETTAGLI' button is located at the bottom of the main content area.



The screenshot shows the Administrator profile interface with the 'DETTAGLI' button highlighted in the bottom bar. The main content area displays the same analysis data as the previous screenshot:

2024-11-25 15:46:40		3089 mBar (A) 25.0 °C	
Potere Calorifico Superiore	10.70 kWh/Sm ³	Metano	95.53 %
Potere Calorifico Inferiore	9.64 kWh/Sm ³	Etano	2.52 %
Indice di Wobbe	14.03 kWh/Sm ³	Propano	0.67 %
Indice di Wobbe Inferiore	12.64 kWh/Sm ³	n-Butano	0.00 %
Massa molare	16.819 kg/kmol	i-Butano	0.10 %
Fattore di compressione (Z)	0.99786	Azoto	0.87 %
Volume molare	0.023594 m ³ /mol	Anidride carbonica	0.32 %
Densità relativa	0.5817	Ossigeno	0.00 %
Densità	0.7128 kg/m ³	Idrogeno	0.00 %
T1: 15.00 °C T2: 15.00 °C		Totale grezzo	101.48 %

The 'DETTAGLI' button is highlighted in the bottom bar.

By clicking on the “Details” button at the bottom of the screen, the following information is available:

- Dark in
- Acquisition
- Dark out
- Spectrum

If you click the "Detail" button while an analysis is running, you will see an error message saying "it is impossible to get information about the last analysis while it is running". You will therefore need to wait until the analysis is finished, that is, when the calculation/analysis in progress symbol is no longer present:

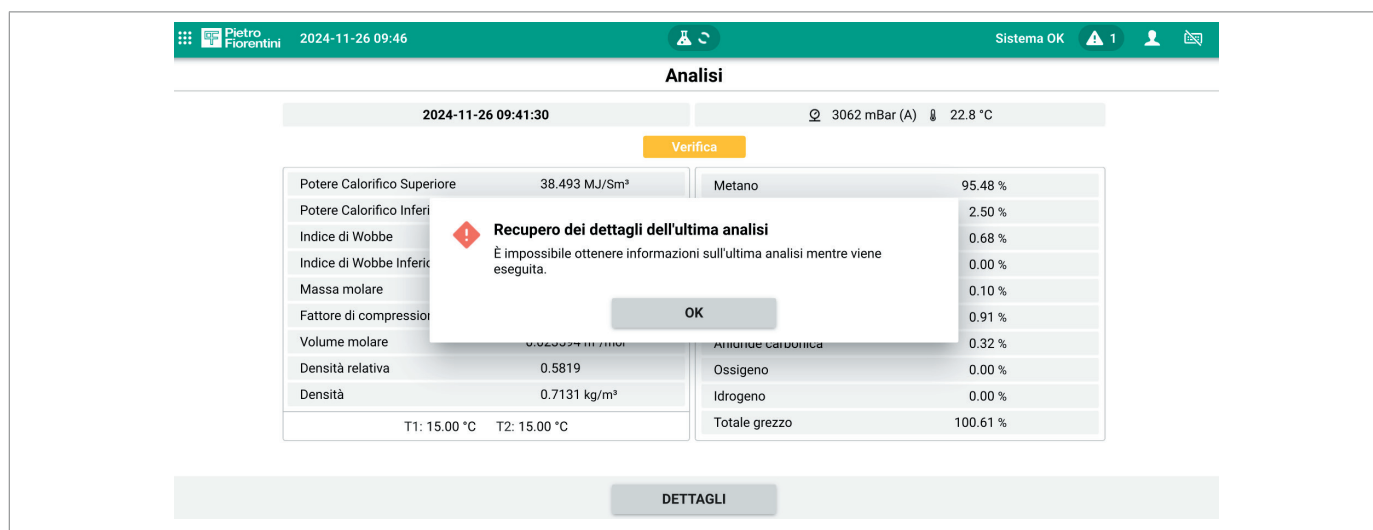
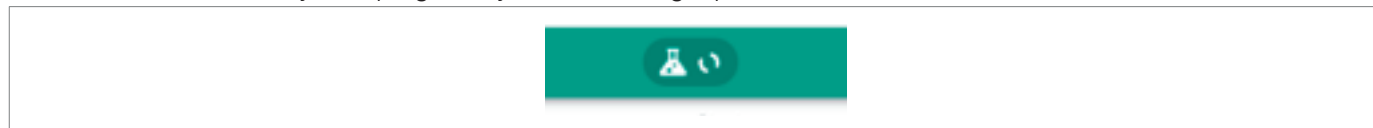

DARK IN

This section presents the images acquired by the camera when the laser is off, before analysis. These images, together with the dark out, are used to generate the reference values (zeros) for each pixel relating to the last analysis performed. The following image can be downloaded by clicking the “Export” button.

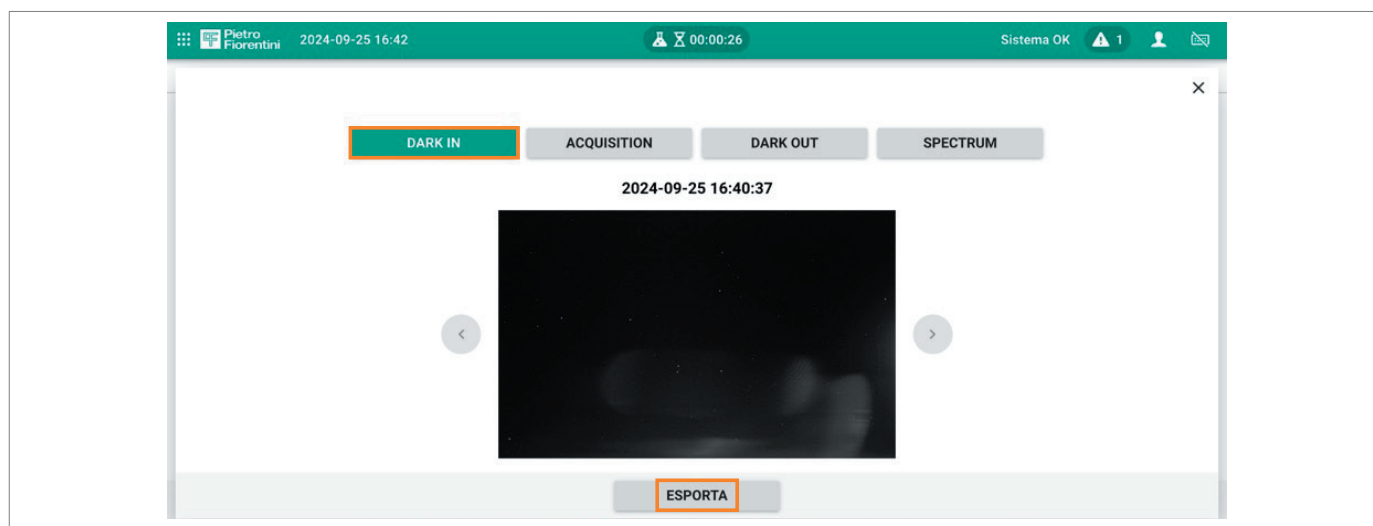

ACQUISITION

The following section shows the image acquired by the camera with the laser turned on.
The following image can be downloaded by clicking the “Export” button.

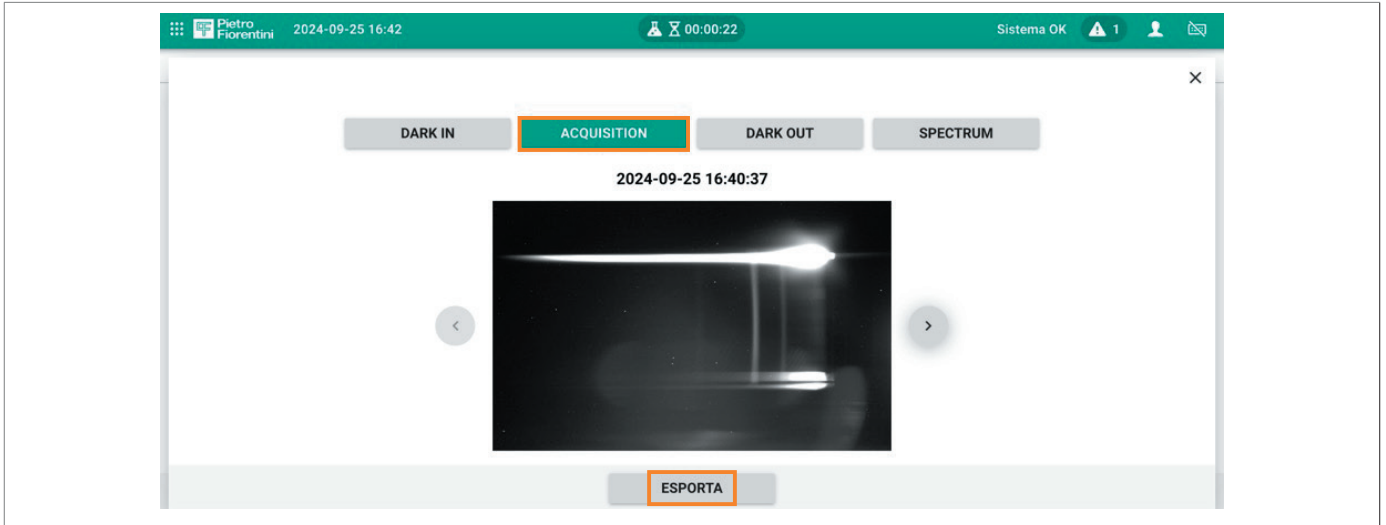

DARK OUT

The following section shows the image acquired by the camera with the laser turned on (after analysis).
The following image can be downloaded by clicking the “Export” button.

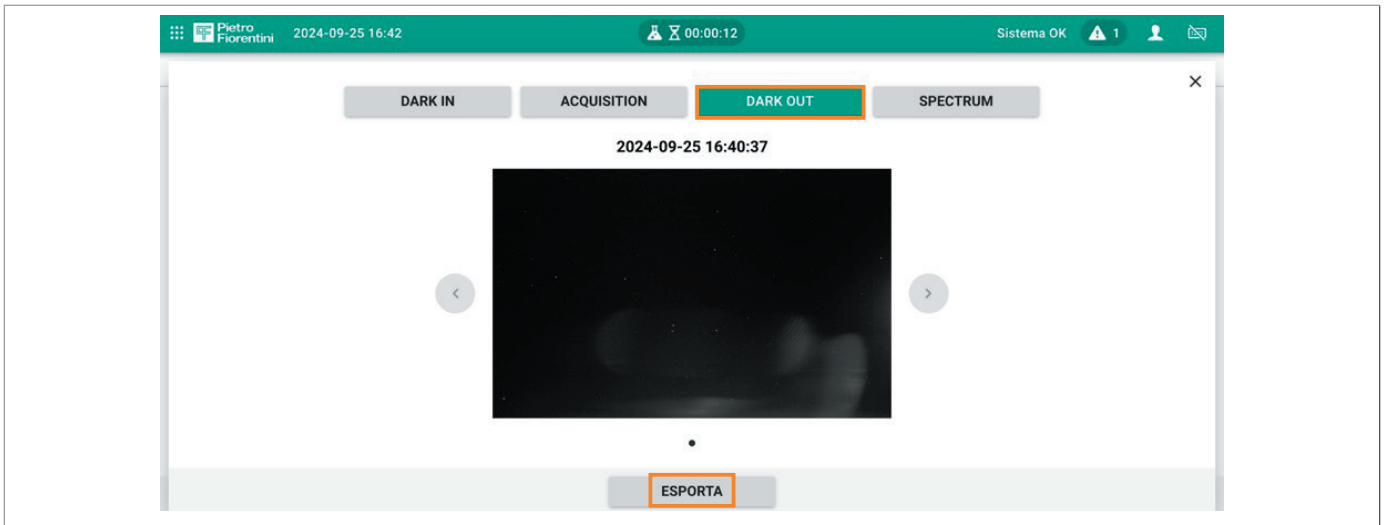

SPECTRUM

Spectrum is the 'frequency' spectrum (i.e. the Raman signal of the gases) that is obtained from the dark in/out and acquisition images through data processing.

By clicking the “Export” button you can download the data relating to the following graph.

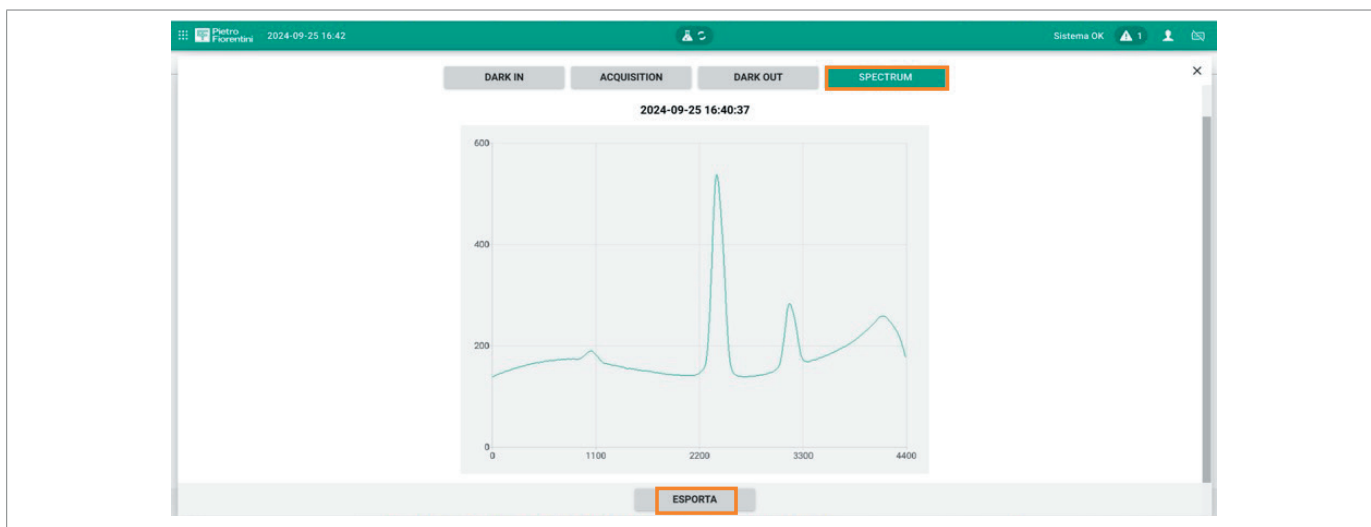

5.6.2 - EVENT SEARCH

In the Administrator profile, in addition to what is indicated in the user profile, it is possible to reset the event history by clicking “RESET”.

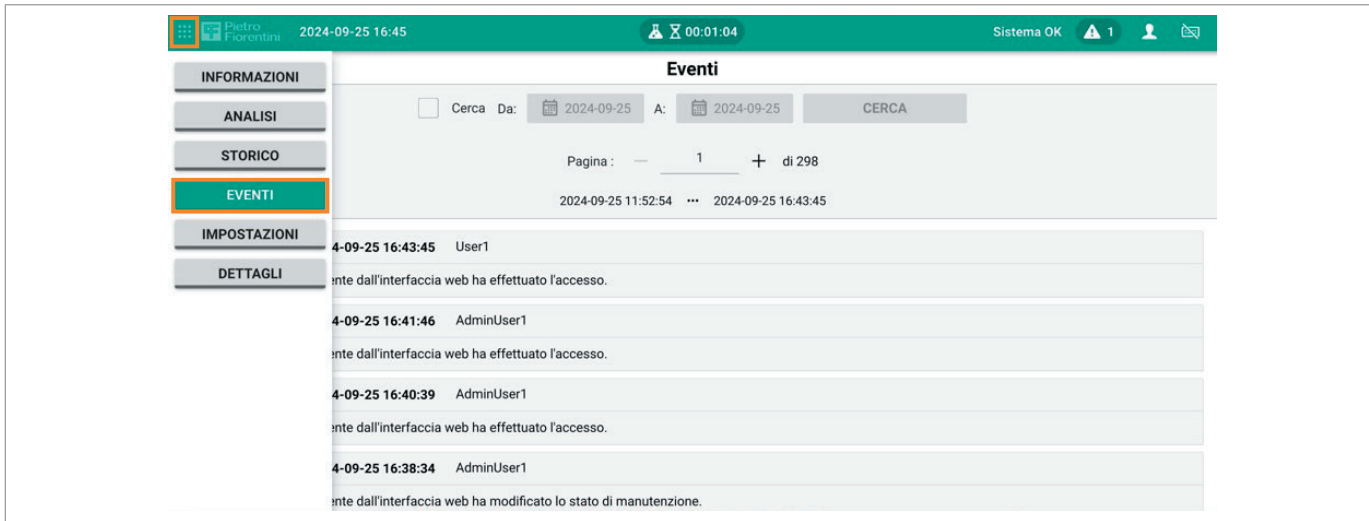

Eventi

Cerca Da: 2024-09-25 A: 2024-09-25 CERCA

Pagina : 1 di 298

2024-09-25 11:52:54 ... 2024-09-25 16:43:45

4-09-25 16:43:45	User1	nte dall'interfaccia web ha effettuato l'accesso.
4-09-25 16:41:46	AdminUser1	nte dall'interfaccia web ha effettuato l'accesso.
4-09-25 16:40:39	AdminUser1	nte dall'interfaccia web ha effettuato l'accesso.
4-09-25 16:38:34	AdminUser1	nte dall'interfaccia web ha modificato lo stato di manutenzione.



Il sistema ha rilevato un errore hardware (Gas Cell Sensor).

3614	2024-09-12 17:59:35	P9	Il sistema ha rilevato un errore hardware (Gas Cell Sensor).
3613	2024-09-12 17:57:33	P9	Il sistema ha rilevato un errore hardware (Gas Cell Sensor).
3612	2024-09-12 17:54:20	P9	Il sistema ha rilevato un errore hardware (Gas Cell Sensor).
3611	2024-09-12 17:35:53	P9	È stato rilevato un errore nel driver Laser: Laser e TEC sono stati spenti.
3610	2024-09-12 16:49:57	P9	Il sistema ha rilevato un errore hardware (Gas Cell Sensor).

ESPORTA RESETTA

By clicking the “RESET” button you are asked to confirm the deletion of all stored events. To delete events click “YES”, otherwise to cancel the operation click “NO”.



If “YES” is selected, a further window will appear asking for the “Password” to continue. If you wish to continue the operation, enter your password and click “CONFIRM”, otherwise click “CANCEL”.

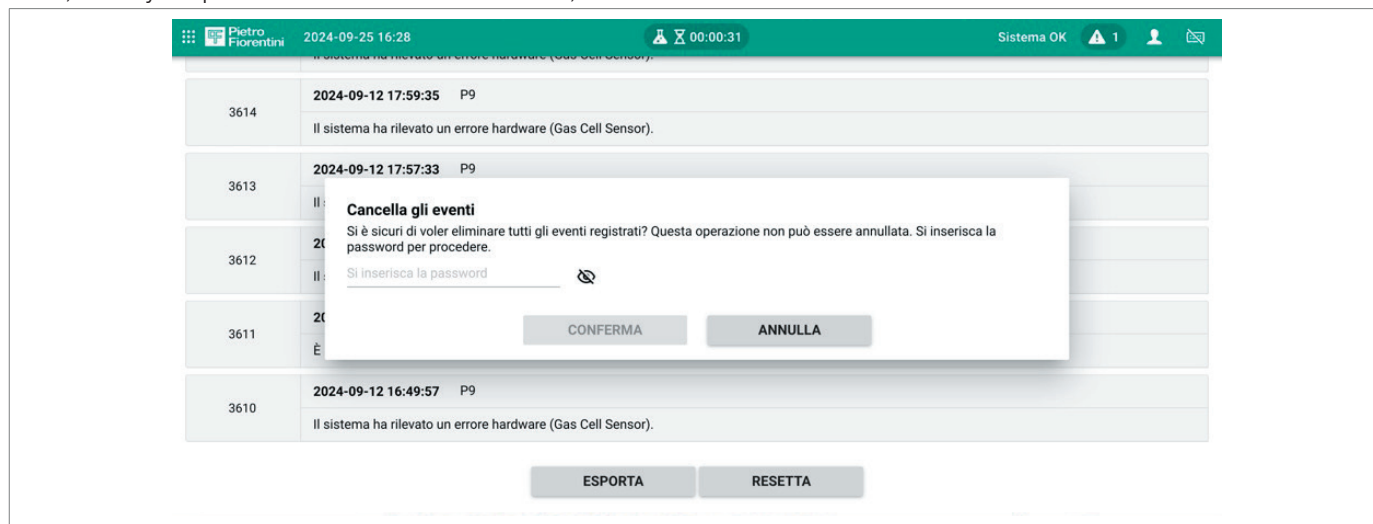

5.6.3 - SETTINGS

The Administrator profile, in addition to what is indicated in the “User” and “Maintenance Technician” profiles, can update the firmware.

5.6.3.1 - FIRMWARE

To access the Firmware section, click on the “dotted square” located next to the Pietro Fiorentini logo. Then click “SETTINGS” in the drop-down menu and then “FIRMWARE”.



To upload the firmware update file, click “UPLOAD”. If you want to interrupt the action during the operation, click 'INTERRUPT'.

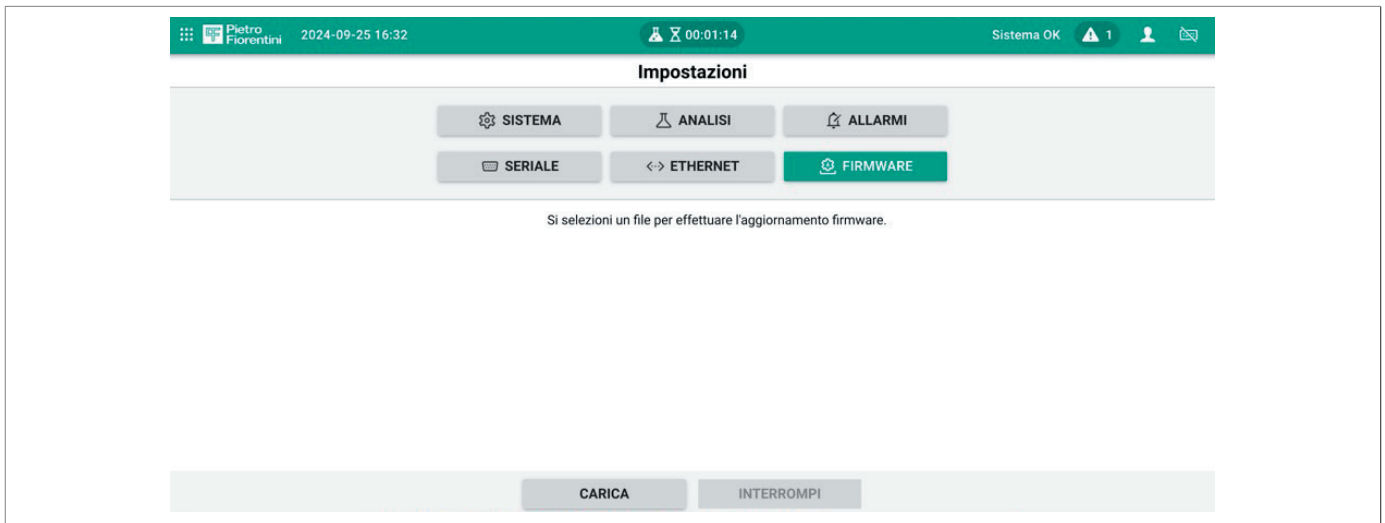

5.6.4 - USERS

The Administrator profile, in addition to what is indicated in the user and maintenance technician profiles, has the ability to modify and/or delete the maintenance technician and user profiles.

To access the “USERS” section and view/edit the profiles available for access, click the “dotted square” located next to the Pietro Fiorentini logo, and select “USERS”.

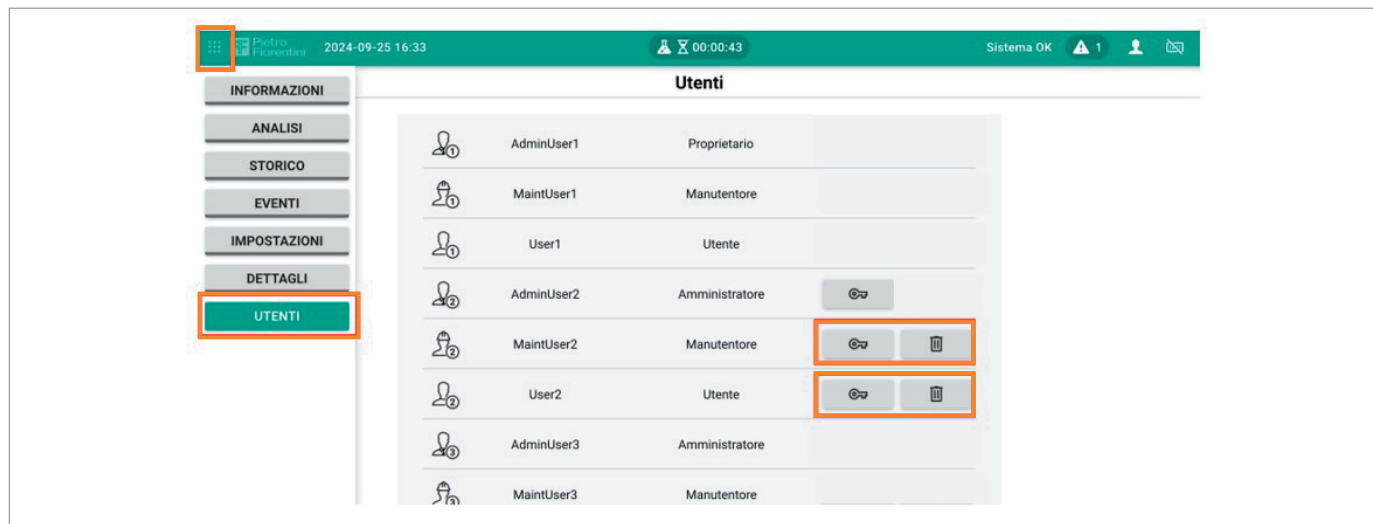

Use this section to:

- View the accounts that can access the device;
- Change your password by clicking the key symbol: to do this, you need to enter your old password, type your new password twice, and then click Save;
- Delete the account by clicking the trash can symbol.

To cancel the operations click on “Cancel”.

You can also add “User” and “Maintenance Technician” profiles using the “+” button at the bottom of the table.

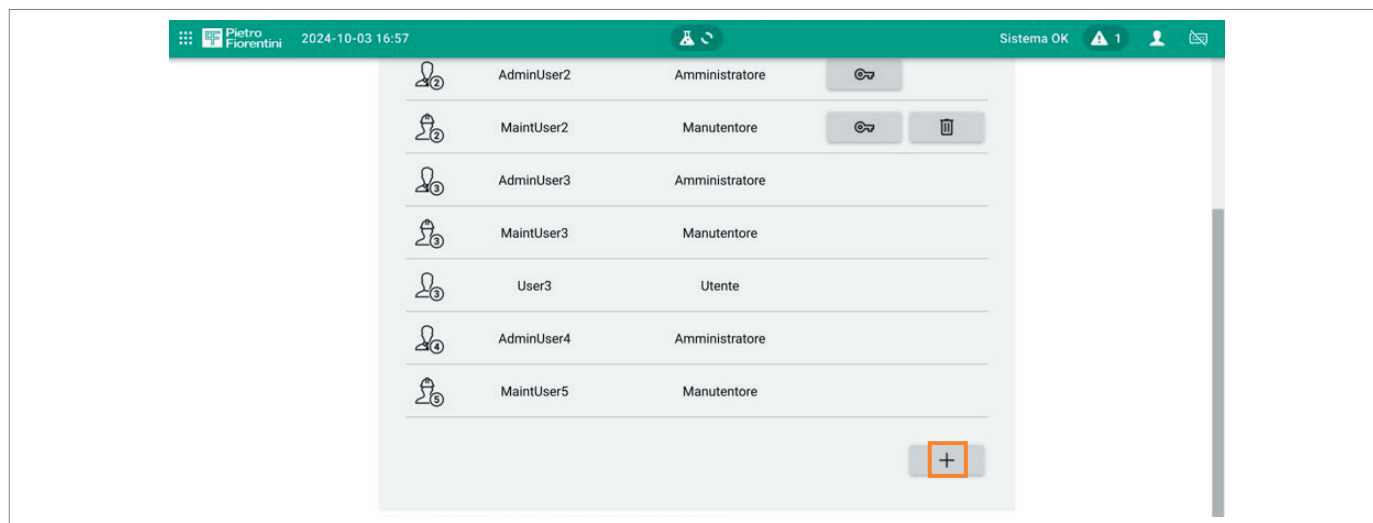

In this specific case, it is possible to add a “User” profile. Select user level, user name, password and confirm password. Once you have added the information, save the changes.

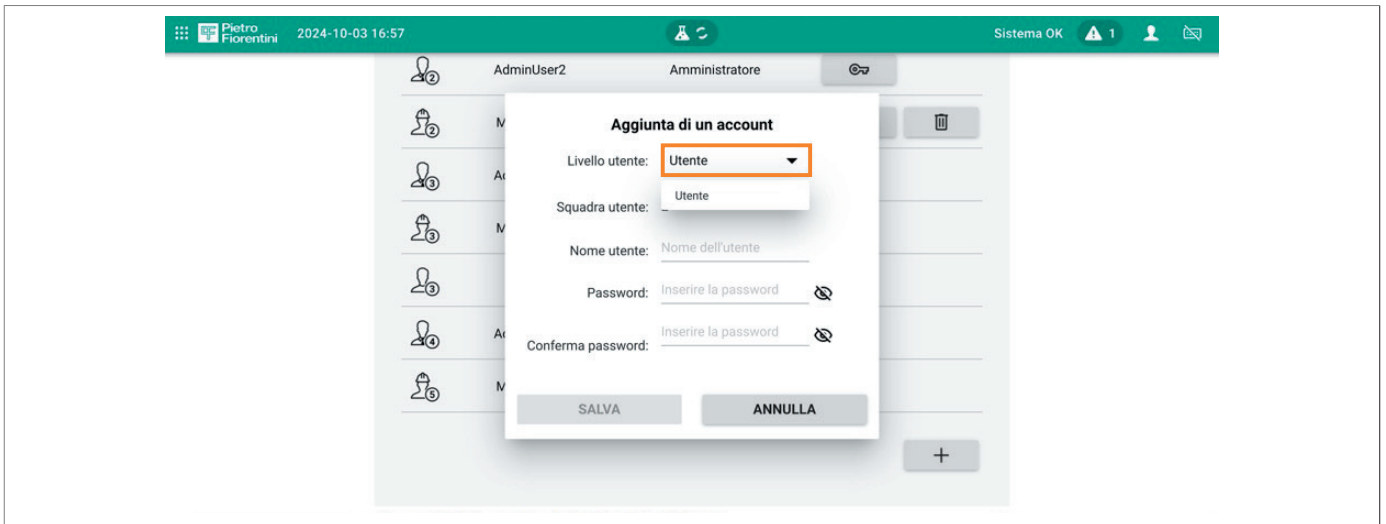

5.7 - PROPRIETARY PROFILE

This profile has the same functionality as an administrator, plus the ability to create new administrator profiles.

5.7.1 - USERS

The owner profile, in addition to what is indicated in the Administrator profile, has the ability to add new Administrator profiles.

To access the “USERS” section and view/edit the profiles available for access, click the “dotted square” located next to the Pietro Fiorentini logo, and select “USERS”.

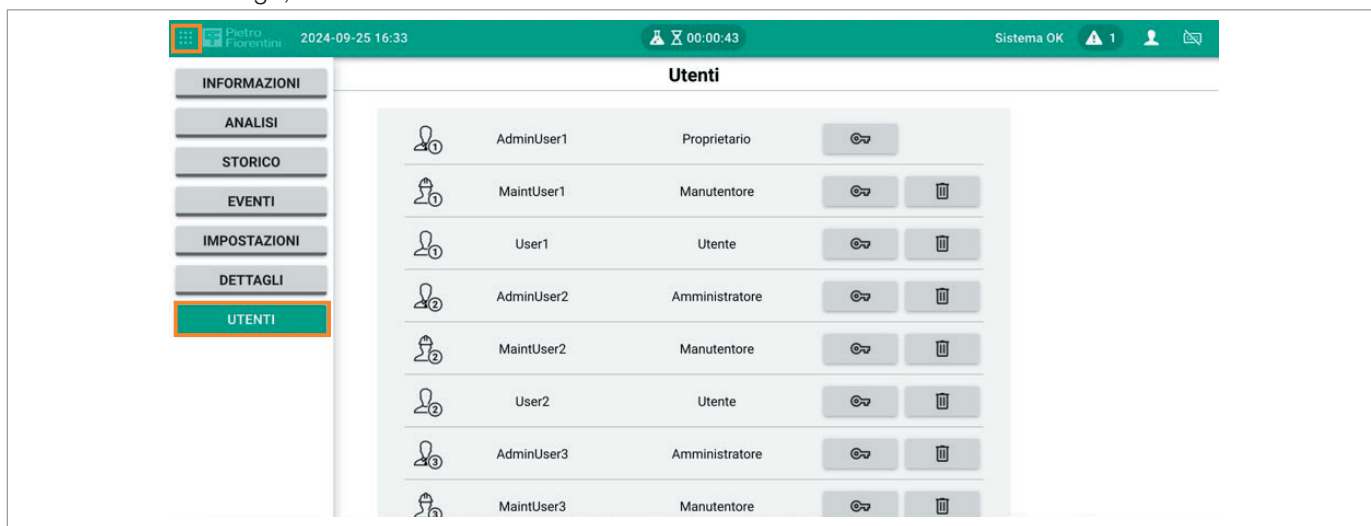

Utenti			
1	AdminUser1	Proprietario	[Edit]
1	MaintUser1	Manutentore	[Edit] [Delete]
1	User1	Utente	[Edit] [Delete]
2	AdminUser2	Amministratore	[Edit] [Delete]
2	MaintUser2	Manutentore	[Edit] [Delete]
2	User2	Utente	[Edit] [Delete]
3	AdminUser3	Amministratore	[Edit] [Delete]
3	MaintUser3	Manutentore	[Edit] [Delete]

You can also add “User” and “Maintenance Technician” profiles using the “+” button at the bottom of the table.

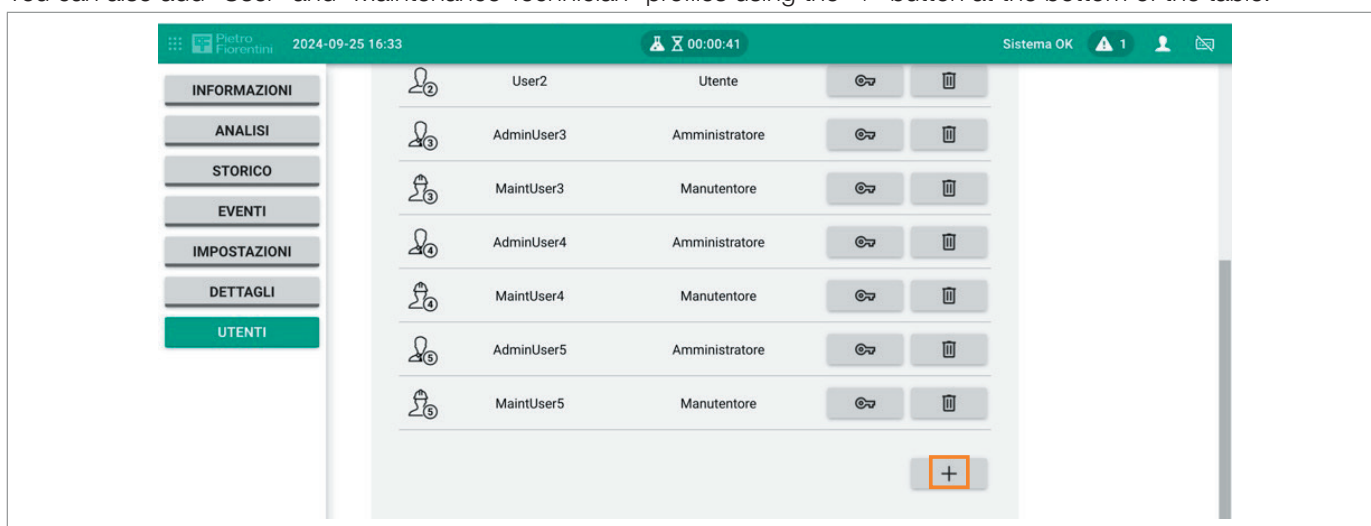

2	User2	Utente	[Edit] [Delete]
3	AdminUser3	Amministratore	[Edit] [Delete]
3	MaintUser3	Manutentore	[Edit] [Delete]
4	AdminUser4	Amministratore	[Edit] [Delete]
4	MaintUser4	Manutentore	[Edit] [Delete]
5	AdminUser5	Amministratore	[Edit] [Delete]
5	MaintUser5	Manutentore	[Edit] [Delete]

[+]

PAGE INTENTIONALLY LEFT BLANK

6 - TRANSPORT AND HANDLING





6.1 - SPECIFIC WARNINGS FOR TRANSPORT AND HANDLING

NOTICE!

Transport and handling must be carried out in compliance with the regulations in force in the country of installation by personnel who are:

- qualified (specially trained);
- who are familiar with accident prevention and workplace safety regulations;
- authorised to use lifting equipment and means.

Transport and handling

Operator qualification	<ul style="list-style-type: none"> • Installer.
PPE required	<div style="display: flex; align-items: center;">     </div> <div style="background-color: #f4a460; padding: 5px; margin-top: 5px;">  WARNING! </div> <p>The PPE listed in this table is related to the risk associated with the equipment. For the required PPE to protect against risks associated with the workplace, installation or operating conditions, please refer to:</p> <ul style="list-style-type: none"> • the regulations in force in the country of installation; • <u>any information provided by the Safety Manager at the installation facility.</u>
Weights and dimensions of the equipment	For dimensions and weights refer to paragraph 6.2 “Physical characteristics of the equipment”.

Tab. 6.19.

6.1.1 - PACKAGING AND FASTENERS USED FOR TRANSPORT

The transport packaging has been designed and manufactured to avoid damage during normal transport, storage and handling. The equipment must be kept in the packaging until installation.

Upon receiving the equipment, it is necessary to:

- make sure that no part of the packaging has been damaged during transport and/or handling;
- immediately report any damage found to PIETRO FIORENTINI S.p.A..

NOTICE!



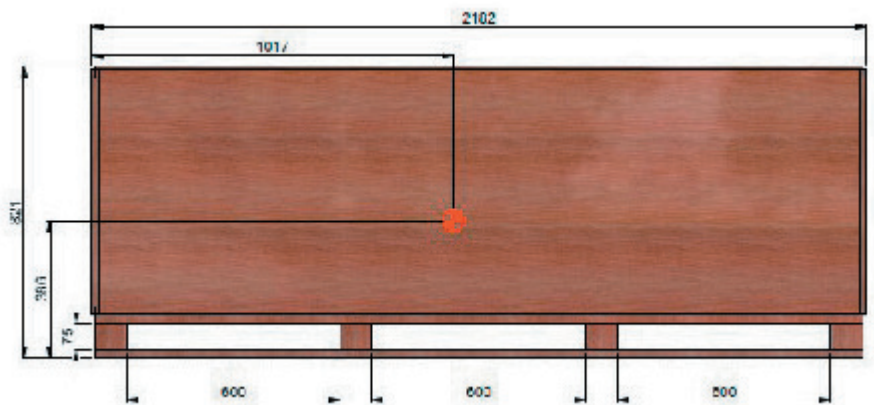
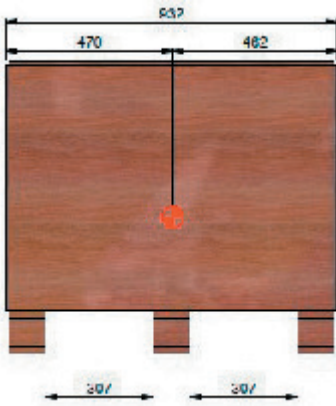

PIETRO FIORENTINI S.p.A. shall not be liable for any damage to people or property caused by accidents due to failure to comply with the instructions provided in this manual.

Symbol	Definition
	Side view from the long side
	Side view from the short side

Tab. 6.20.

6.1.2 - MARKINGS AND WARNINGS

Markings are applied to the packaging to highlight:

Symbol	Description
	The contents of the package are FRAGILE. This is due to the optical system of the instrument.
	Handle the packaging with care.
	It indicates the direction of how the package should be placed. The horizontal line represents the base.
	Do not stack. To indicate that packages must not be stacked vertically, both due to the nature of the transport packaging and the nature of the items themselves.
	The packaging is recyclable.

Tab. 6.21.

6.2 - PACKAGING CONTENT

The instrument is supplied in a non-stackable plywood crate and already mounted on a frame. The necessary screws for wall or floor installation using a frame are supplied. For further details, refer to chapter “7.6 - Acquisition module installation diagram”.

NOTICE!

The use, maintenance and warning manual can be downloaded from the Manufacturer's website:
<https://www.fiorentini.com>

6.3 - PHYSICAL CHARACTERISTICS OF THE COMPONENTS

6.3.1 - ACQUISITION MODULE GEDRA IN HAZARDOUS AREAS

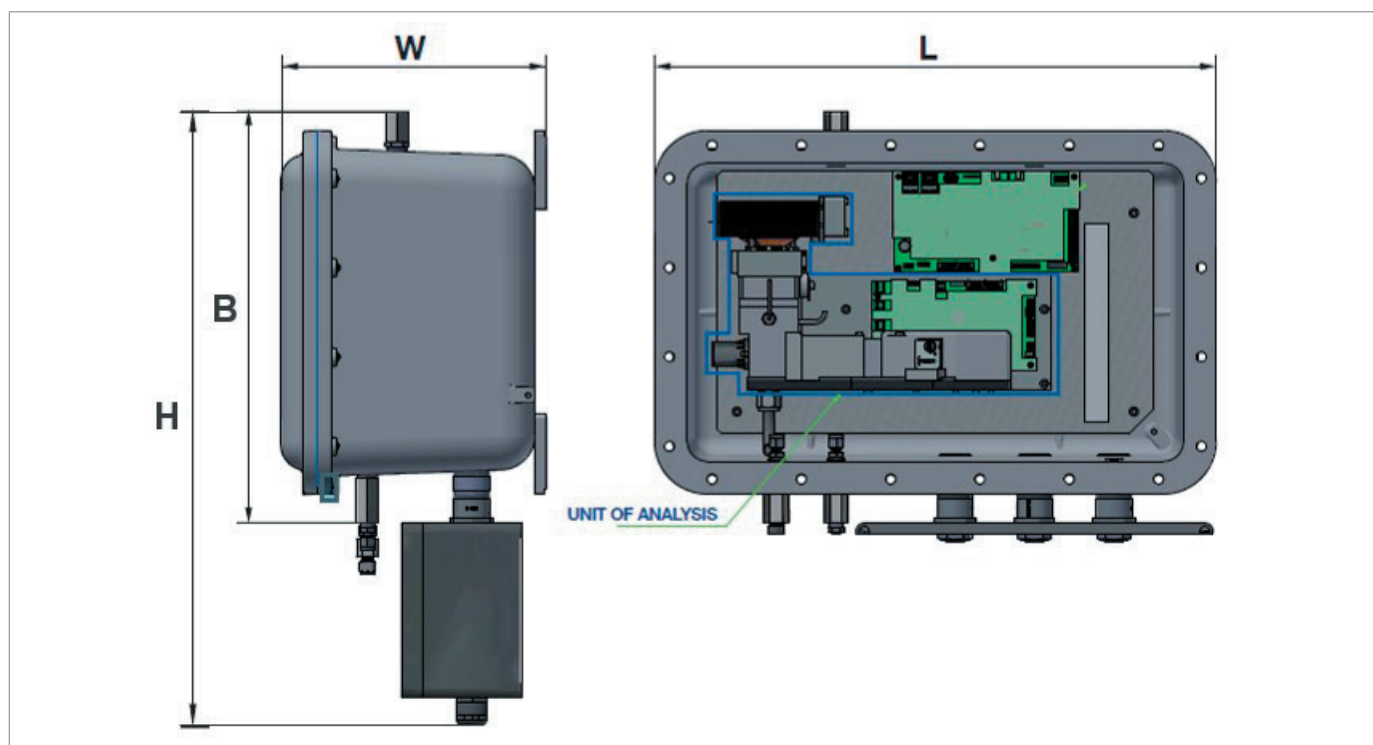

Fig. 6.25. Acquisition module in hazardous areas - configuration 1

Weights and dimensions		
Overall dimensions		
H	619 mm	24.4 inches
B	440 mm	17.3 inches
L	640 mm	25.2 inches
W	278 mm	10.9 inches
Weight		
	65 Kg	110.0 lbs

Tab. 6.22.

6.3.2 - PNEUMATIC PANEL GEDRA

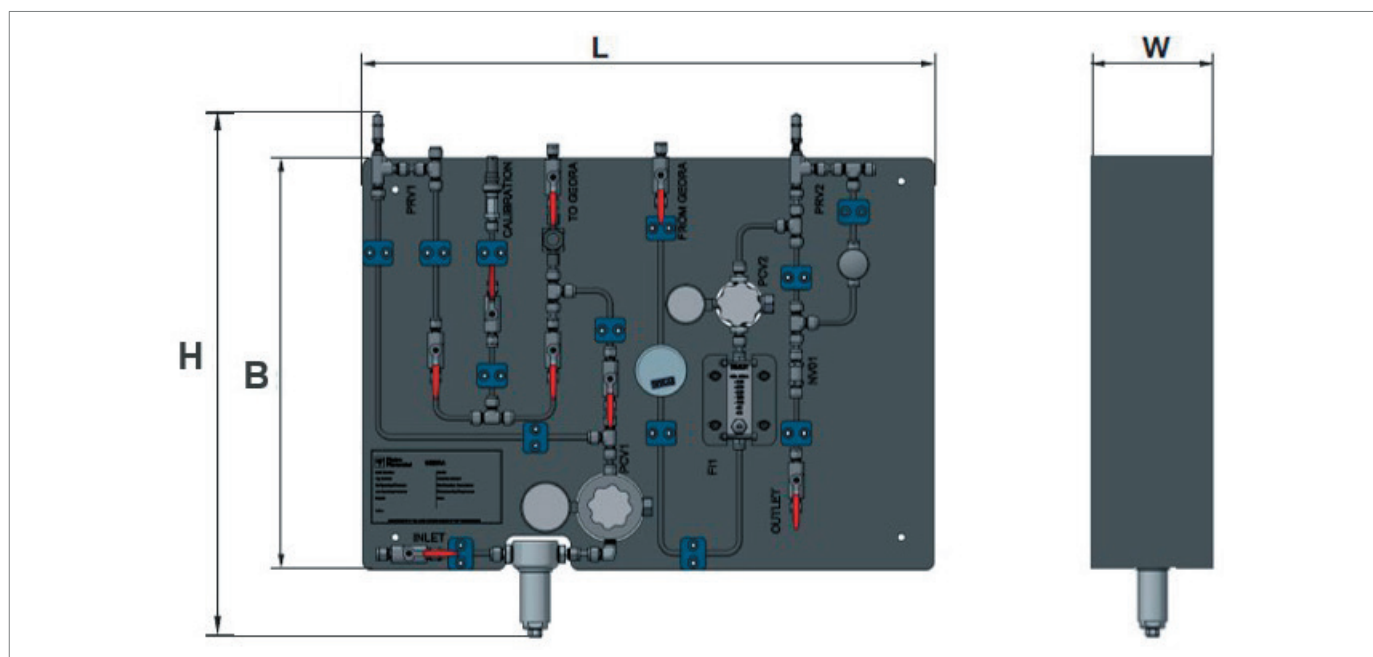

Fig. 6.26. Pneumatic panel

Weights and dimensions

Overall dimensions

H	631 mm	24.9 inches
B	500 mm	19.7 inches
L	700 mm	27.5 inches
W	150 mm	5.9 inches

Weight

	20 Kg	44 lbs
--	-------	--------

Tab. 6.23.

6.3.3 - FIELD DISPLAY GEDRA IN SAFE AREAS

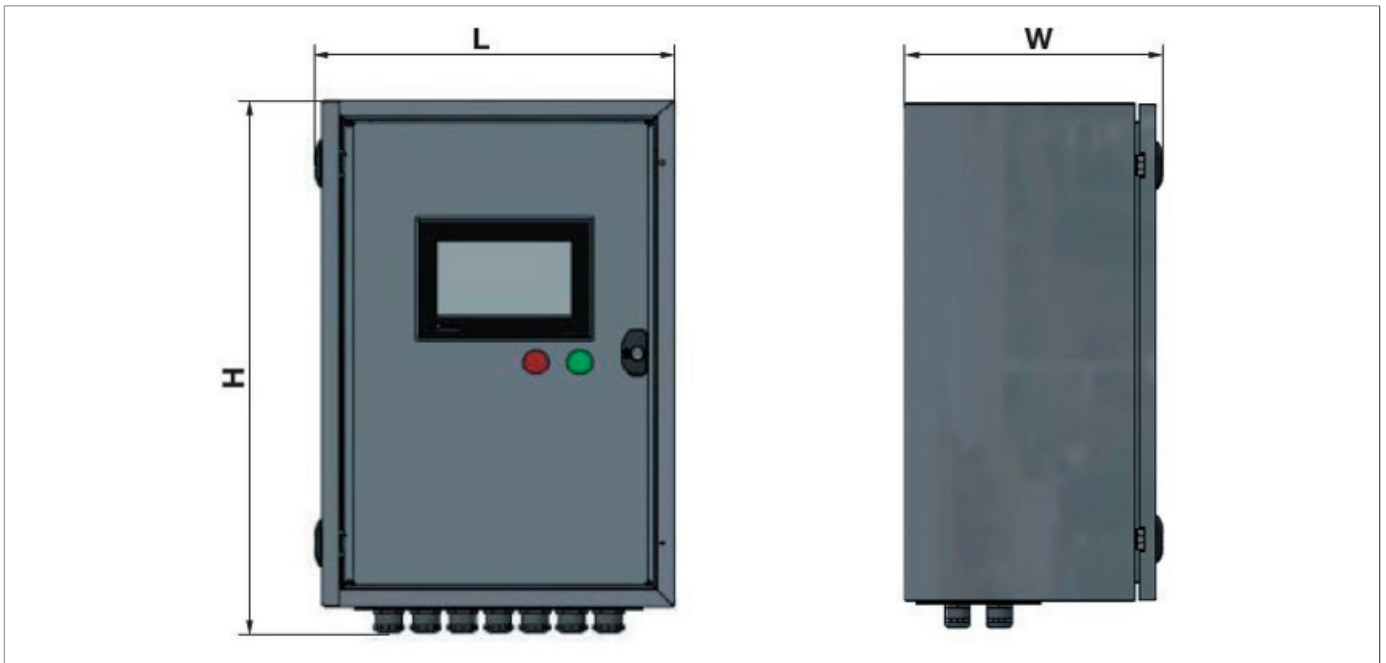

Fig. 6.27. Interface module in safe areas

Weights and dimensions		
Overall dimensions		
H	500 mm	19.7 inches
L	400 mm	15.7 inches
W	200 mm	7.9 inches
Weight		
	20 Kg	77.2 lbs

Tab. 6.24.

6.4 - PHYSICAL CHARACTERISTICS OF THE FRAME GEDRA

6.4.1 - ASSEMBLED ASSEMBLY VIEW

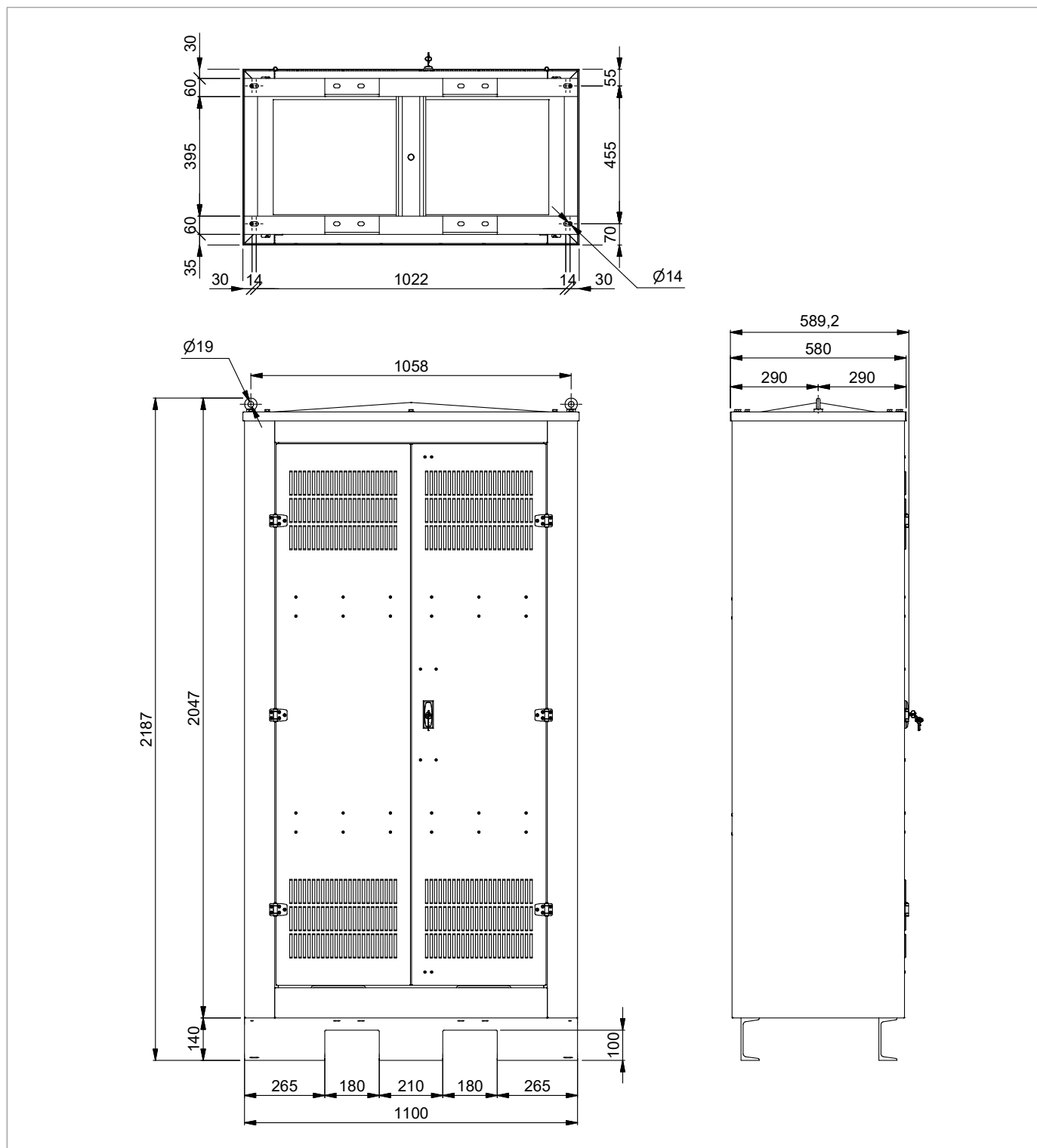

Fig. 6.28. Assembled assembly view

Weights [kg]	
Assembled assembly	155

Tab. 6.25.

6.5 - EQUIPMENT ANCHORING AND LIFTING METHOD

 **HAZARD!**

Using lifting equipment (if necessary) for unloading, carrying and handling packages is reserved only for skilled operators who have been properly trained and instructed (with licence if required by the regulations in force in the country of installation) and are familiar with:

- accident prevention rules;
- workplace safety provisions;
- lifting equipment features and limits.

 **HAZARD!**

Before handling a load, make sure that its weight does not exceed the load capacity of the lifting equipment (and any other lifting tools) specified on the specific plate.

 **ATTENTION!**

Before handling the equipment:

- remove any movable or hanging component or firmly secure it to the load;
- protect the most fragile equipment;
- check that the load is stable;
- be sure to have perfect visibility along the route.

6.5.1 - FORKLIFT HANDLING METHOD

HAZARD!

It is forbidden to:

- transit under suspended loads;
- move the load over the personnel operating in the site/plant area.

WARNING!

The following is not allowed on forklifts:

- carrying passengers;
- lifting people.

WARNING!

During all handling operations, pay close attention to avoid impact or vibrations of the equipment batteries.

If cardboard boxes (single or multiple) are carried on a pallet, proceed as indicated in Tab. 6.26:

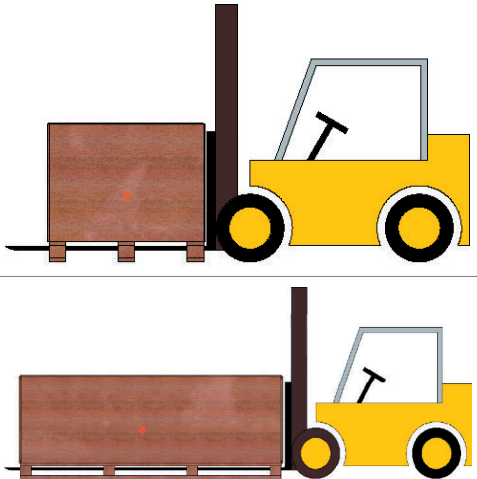
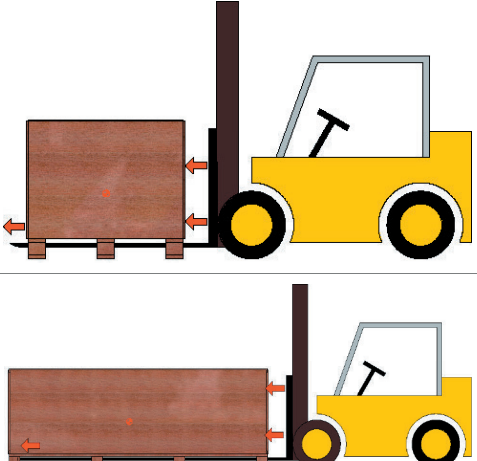
Step	Action	Image
1	<p>Place the forks of the forklift under the load surface. Depending on the type of forklift, two scenarios arise:</p> <ul style="list-style-type: none"> • Forklift with long forks: lengthwise entry (Configuration 1.A) • Forklift with standard forks (1200 mm): side entry (Configuration 1.B) 	
2	<p>Make sure that the forks protrude from the front of the load (by at least 5 cm), far enough to eliminate any risk of the transported load tipping.</p>	

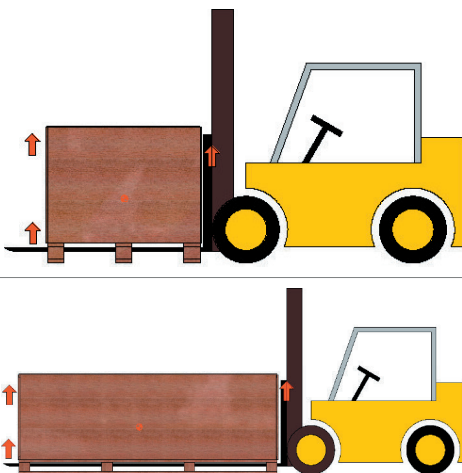
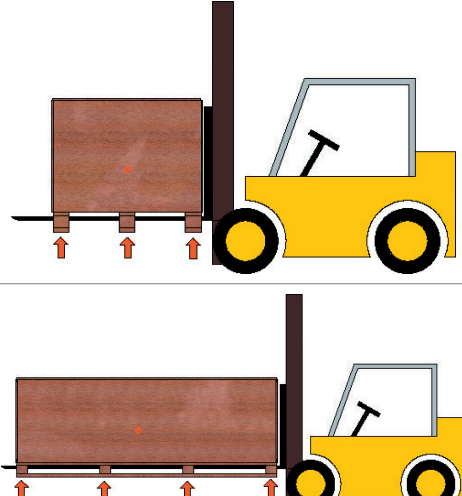
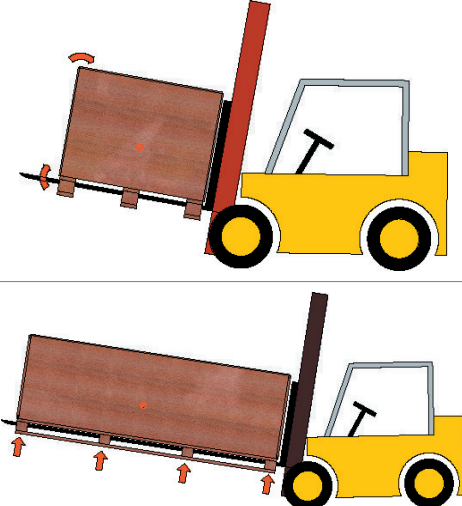
Step	Action	Image
3	<p>Raise the forks until they are touching the load.</p> <div style="border: 1px solid blue; padding: 5px; margin-top: 10px;"> <p>NOTICE! Fasten the load to the forks with clamps or similar devices if required.</p> </div>	
4	<p>Slowly lift the load by a few dozen centimetres and check its stability, making sure that the centre of gravity of the load is at the centre of the lifting forks.</p>	
5	<p>Tilt the mast backwards (towards the driver's seat) to help the over-turning moment and to ensure greater load stability during transport.</p>	

Step	Action	Image
6	<p>Adjust transport speed according to the type of floor and load, avoiding jerky movements.</p> <p> WARNING!</p> <p>In the event that:</p> <ul style="list-style-type: none"> • obstacles along the path; • particular operating situations; <p>hinder operator visibility, the assistance of a ground operator is required, standing outside the range of action of the lifting equipment, with the task of signalling.</p>	
7	Place the load in the chosen installation area.	

Tab. 6.26.

6.5.2 - FRAME HANDLING

If the equipment GEDRA is supplied already mounted on the frame, use the eyebolt on the top of the frame for handling. Use a folding hydraulic crane. Pay attention to the maximum load capacities for the frame:

- indoor frame: 155 kg
- outdoor frame 370 kg.

If necessary, remove the eyebolt after handling.

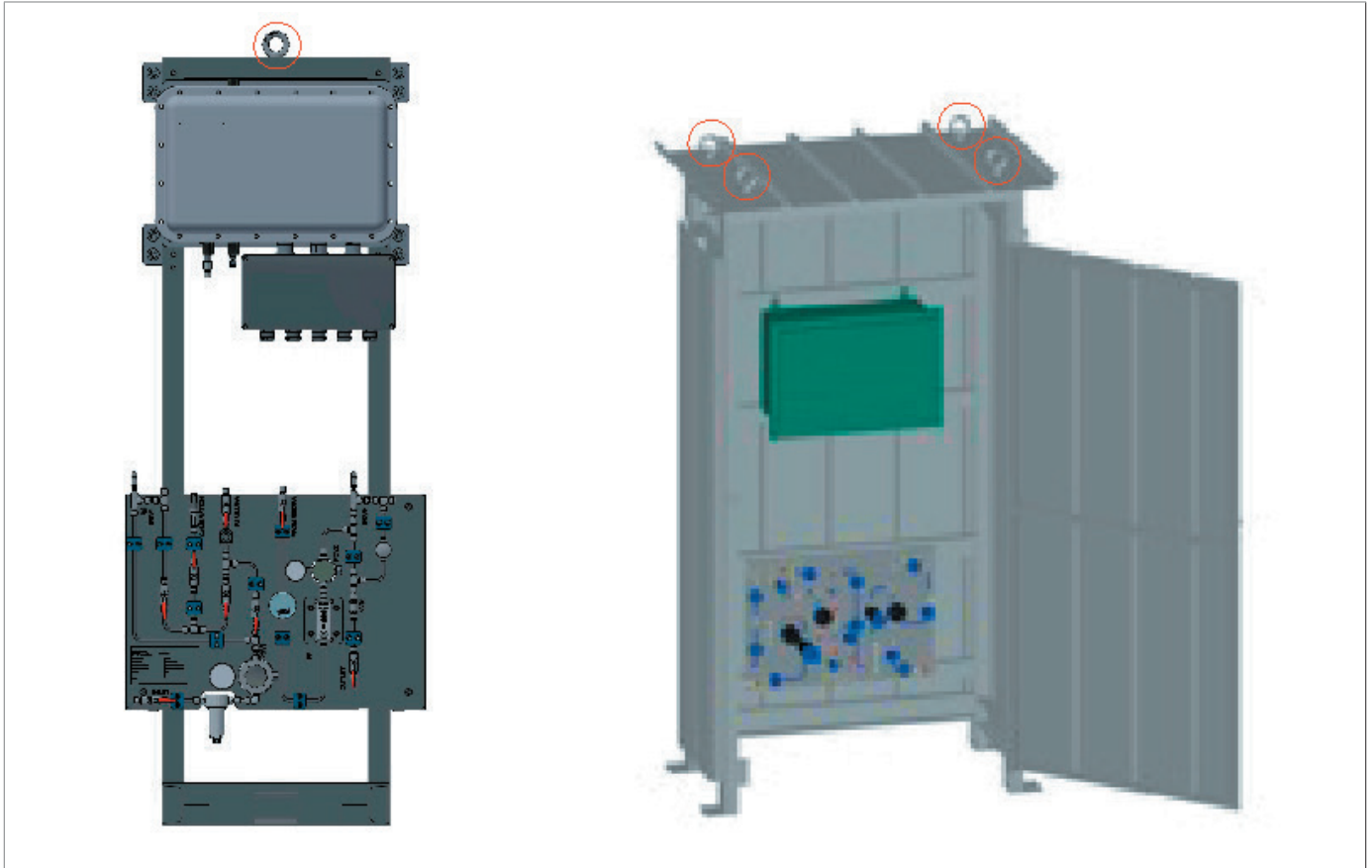

Fig. 6.29. Indoor and outdoor frame handling

6.5.3 - HANDLING OF THE ANALYSIS MODULE

If the equipment GEDRA is installed on the wall or if only the analysis module needs to be handled, use a two-wheeled transport trolley.

Secure the module with belts or straps. The estimated weight of the module is 65 kg.

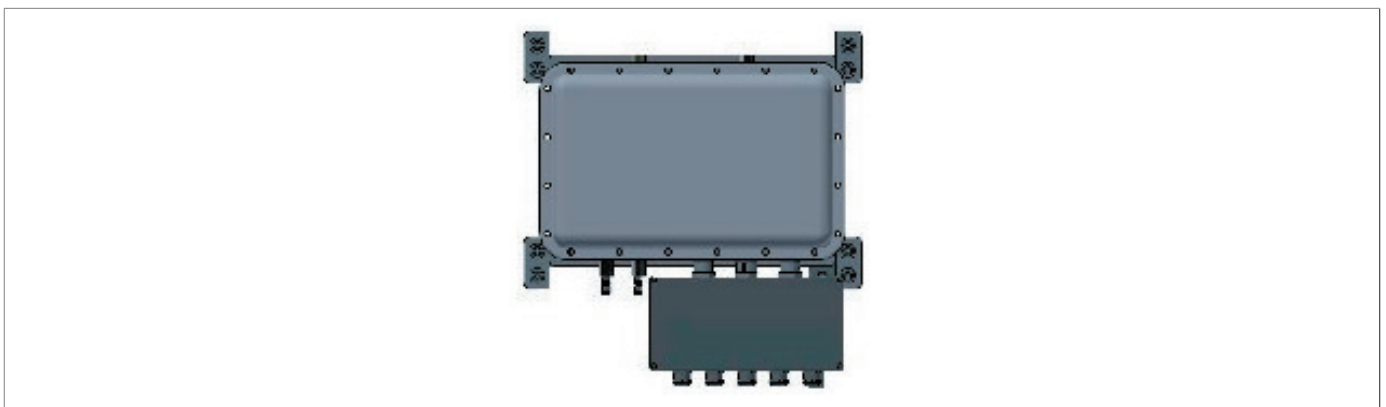

Fig. 6.30. Handling of the analysis module installed on the wall

6.5.4 - PNEUMATIC PANEL HANDLING

If the equipment GEDRA is installed on the wall or if you only need to move the pneumatic panel, use a two-wheeled transport trolley.

Secure the module with belts or straps. The estimated weight of the module is 25 kg.

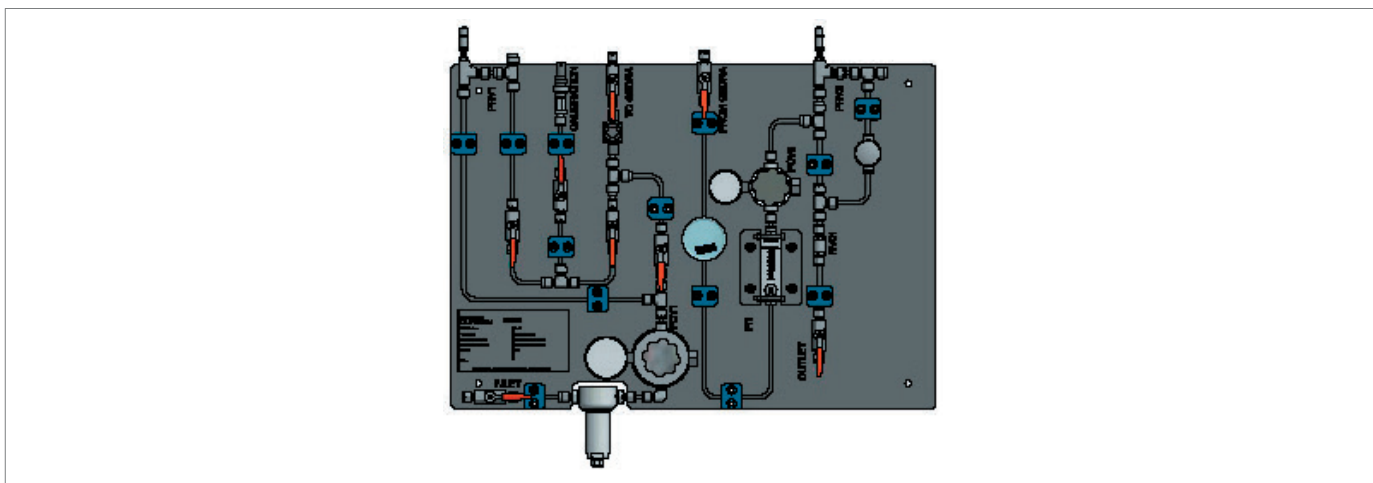

Fig. 6.31. Handling of pneumatic panel installed on the wall

6.5.5 - FIELD DISPLAY HANDLING

To handle the field display, use a two-wheeled transport trolley.

Secure the module with belts or straps. The estimated weight of the module is 35 kg.

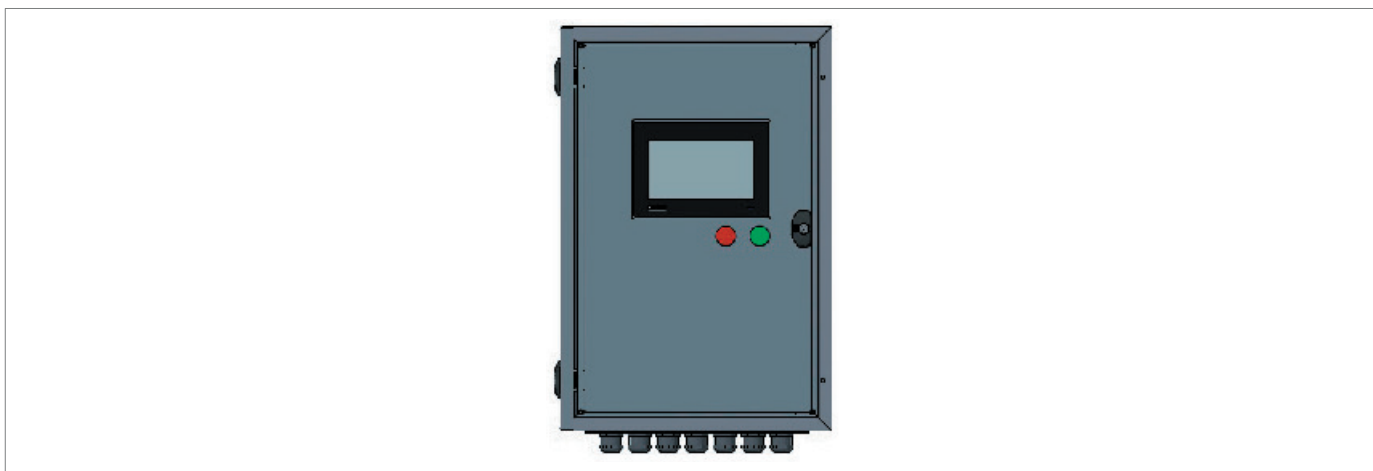



Fig. 6.32. Field display handling

6.6 - PACKAGING REMOVAL

Packaging removal	
Operator qualification	<ul style="list-style-type: none"> Installer.
PPE required	 <p>WARNING!</p> <p>The PPE listed in this table is related to the risk associated with the equipment. For the PPE necessary to protect against risks associated with the workplace or operating conditions, please refer to:</p> <ul style="list-style-type: none"> the regulations in force in the country of installation; <u>any information provided by the Safety Manager at the installation facility.</u>

Tab. 6.27.

To unpack, proceed as described in Tab. 6.28:

Step	Action
1	Remove the stretch film around the pallet.
2	Remove the 4 support corners.
3	Remove the cover.
4	Remove the sides.
5	Separate the internal components: field displays, tubes, cables, etc.
6	Move the boxes of the equipment from the pallet to their intended place. <div style="border: 1px solid blue; padding: 5px; margin-top: 10px;"> <p>NOTICE!</p> <p>Have at least 2 operators manually move the packages if required due to their dimensions/weight.</p> </div>

Tab. 6.28.

NOTICE!

After removing all packaging materials, check for any anomalies.

If there are anomalies:

- do not install the equipment;
- contact PIETRO FIORENTINI S.p.A. and specify the details provided on the equipment rating plate.

WARNING!

The single piece of equipment is contained in a specifically created cardboard box.

Avoid taking the equipment out of the box before its installation.

6.6.1 - PACKAGING DISPOSAL

NOTICE!

Sort the various materials making up the packaging and dispose of them in compliance with the regulations in force in the country of installation.

6.7 - STORAGE AND ENVIRONMENTAL CONDITIONS

⚠ WARNING!

Protect the equipment from blows and impacts, even accidental, until it is installed.

! NOTICE!

The equipment must be stored in an upright position.

If the equipment needs to be stored for an extended period, the minimum environmental conditions for the intended storage are provided in Tab. 6.29. Compliance with these conditions will guarantee the declared performance:

Operational	Data
Maximum storage period	A maximum storage period is not defined as it is only limited by the life span of the product.
Storage temperature	from -25°C to +60°C
Relative humidity	95%

Tab. 6.29.

PAGE INTENTIONALLY LEFT BLANK

7 - INSTALLATION

7.1 - GENERAL WARNINGS

WARNING!

Exposing the equipment to the environment without using protective caps or incorrectly installing filters can significantly compromise system performance, reducing the accuracy and reliability of measurements. To prevent dirt, dust, or other foreign particles from contaminating the analyzer and impairing its functionality, specific preventive measures must be taken.

To ensure maximum accuracy of the analyzer, it is essential to always keep the Ex-d cap installed on the Ex-d box of the analysis module, even after the installation is complete.

Carefully check that the filters are correctly installed in the pneumatic panel, ensuring that they are well positioned and suitable for the required specifications.

WARNING!

The installation must be performed by qualified personnel, in compliance with the provisions in force concerning safety.

WARNING!

For the safe use of the equipment, respect the permitted environmental conditions and comply with the data shown on the nameplate.

WARNING!

It is strictly forbidden to make any modifications to the equipment.

WARNING!

PIETRO FIORENTINI S.p.A. is not liable for damage caused by incorrect installation of the equipment and/or otherwise different from that indicated in this manual.

7.2 - INSTALLATION PRE-REQUISITES

7.2.1 - ENVIRONMENTAL CONDITIONS ALLOWED

NOTICE!

For details on the allowed environmental conditions (temperature range and classification) refer to paragraph "4.9 - Technical data".

WARNING!

PIETRO FIORENTINI S.p.A. is not liable for damage and/or malfunctions caused by installation in environments other than those permitted.

7.3 - EQUIPMENT NEEDED FOR INSTALLATION

Ref.	Equipment type	Image
A	Key for fixing: <ul style="list-style-type: none"> • fittings (size: 15 mm) • equipment input and output connections 	-
B	Pipe cutter for 6 mm SS316 pipe	-
C	Key to fix the frame to the floor (size: 16 mm)	-
D	Drill	-

Tab. 7.30

If present, locate the gas sampling point upstream of the adjustment section.

Alternatively, sampling must always be carried out before the measurement section. The re-injection point (exclusively for the type 1 configuration) must instead be located downstream of the adjustment section, before the measurement section.

For the connection, a ½" NPT or ½" GAS connection is required. In the case of existing systems, to ensure the continuity of the gas flow without interruptions, identify two gas sampling points upstream of the adjustment section.



7.4 - CHECKS BEFORE INSTALLATION

The installation site must be suitable for the safe use of the equipment.

The equipment installation area must have lighting that guarantees the operator good visibility during the installation phases.

Before installation, it must be ensured that:

- the installation compartment meets the provisions in force on safety and is away from any possible damage of mechanical origin, away from sources of heat or naked flames, in a dry place and protected from external agents;
- the utilities on the customer side are closed;
- there are no impediments that could hinder the installer's installation operations;
- the upstream and downstream pipes are at the same level and can bear the weight of the equipment;
- there are no stresses on the connections;
- the inlet and outlet connections of the equipment are clean and have not been damaged;
- mechanical stresses on the inlet and outlet connections are totally absent.

Installation	
Operator qualification	<ul style="list-style-type: none"> • Installer.
PPE required	<div style="display: flex; align-items: center;">  </div> <div style="background-color: #ff8c00; padding: 5px; margin-top: 5px;">  WARNING! </div> <p>The PPE listed in this table is related to the risk associated with the equipment. For the required PPE to protect against risks associated with the workplace, installation or operating conditions, please refer to:</p> <ul style="list-style-type: none"> • the regulations in force in the country of installation; • <u>any information provided by the Safety Manager at the installation facility.</u>
Equipment required	Keys to fix inlet and outlet connections fittings/connections of the equipment.

Tab. 7.31.

7.5 - SPECIFIC SAFETY INSTRUCTIONS FOR THE INSTALLATION PHASE

WARNING!

Before proceeding with installation, make sure that the upstream and downstream valves installed on the line are shut off.

WARNING!

Installation may also take place in areas where there is a risk of explosion, which implies that all necessary prevention and protection measures have to be taken.

For these measures, please refer to the regulations in force at the place of installation.

WARNING!

Near the equipment, do not:

- use open flames (e.g. for welding operations);
- smoke.

WARNING!

Install the equipment in the position shown in the assembly drawing. For the direction of gas flow, observe the inlet and outlet pipes.

WARNING!

When installing the equipment:

- avoid mechanical stresses on its inlet/outlet connections;
- implement protective measures against electrostatic discharges.

7.6 - ACQUISITION MODULE INSTALLATION DIAGRAM

Fig. 7.34 and Fig. 7.36 show the possible installation diagrams in hazardous areas for the acquisition module.

- Configuration type 1: installation of the acquisition module with gas reinjection into the measuring line in the presence of the adjustment section.
- Configuration type 2: installation without reinjection of gas into the measuring line in the absence of the adjustment section.

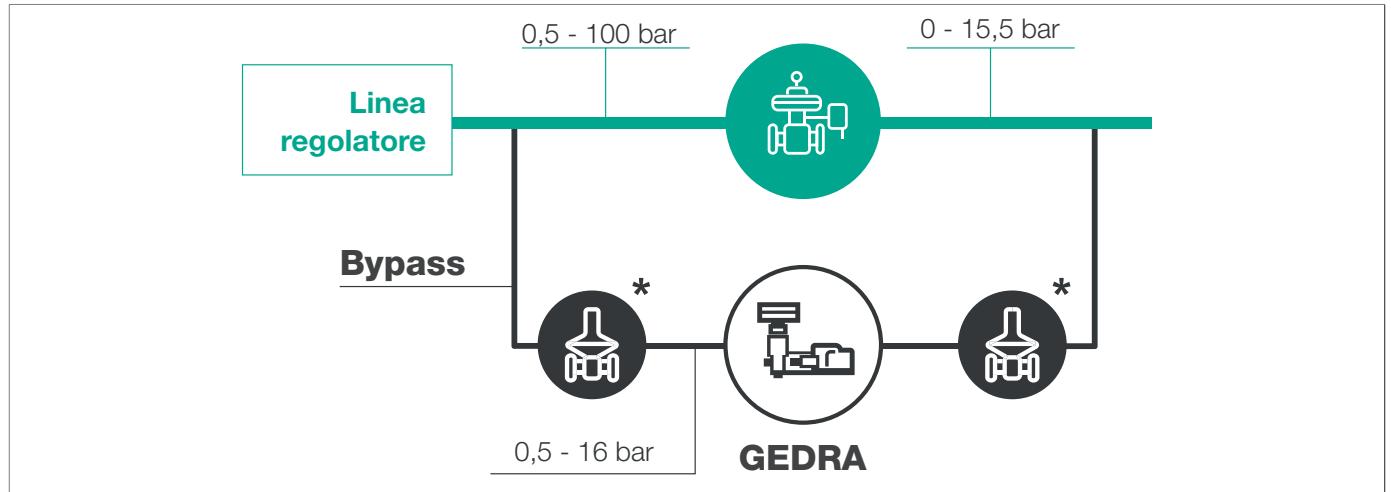

Fig. 7.33. Type 1 configuration of the acquisition module

Below is a typical representation of the P&ID (Piping and Instrument Diagram) for type 1 configuration of the acquisition module.

As shown in the diagram, to avoid interrupting the gas flow in the case of existing cabins, identify two gas sampling points upstream of the adjustment section, immediately after the filters (if present). If the adjustment section is not present, the gas sampling points must be identified upstream of the measuring section

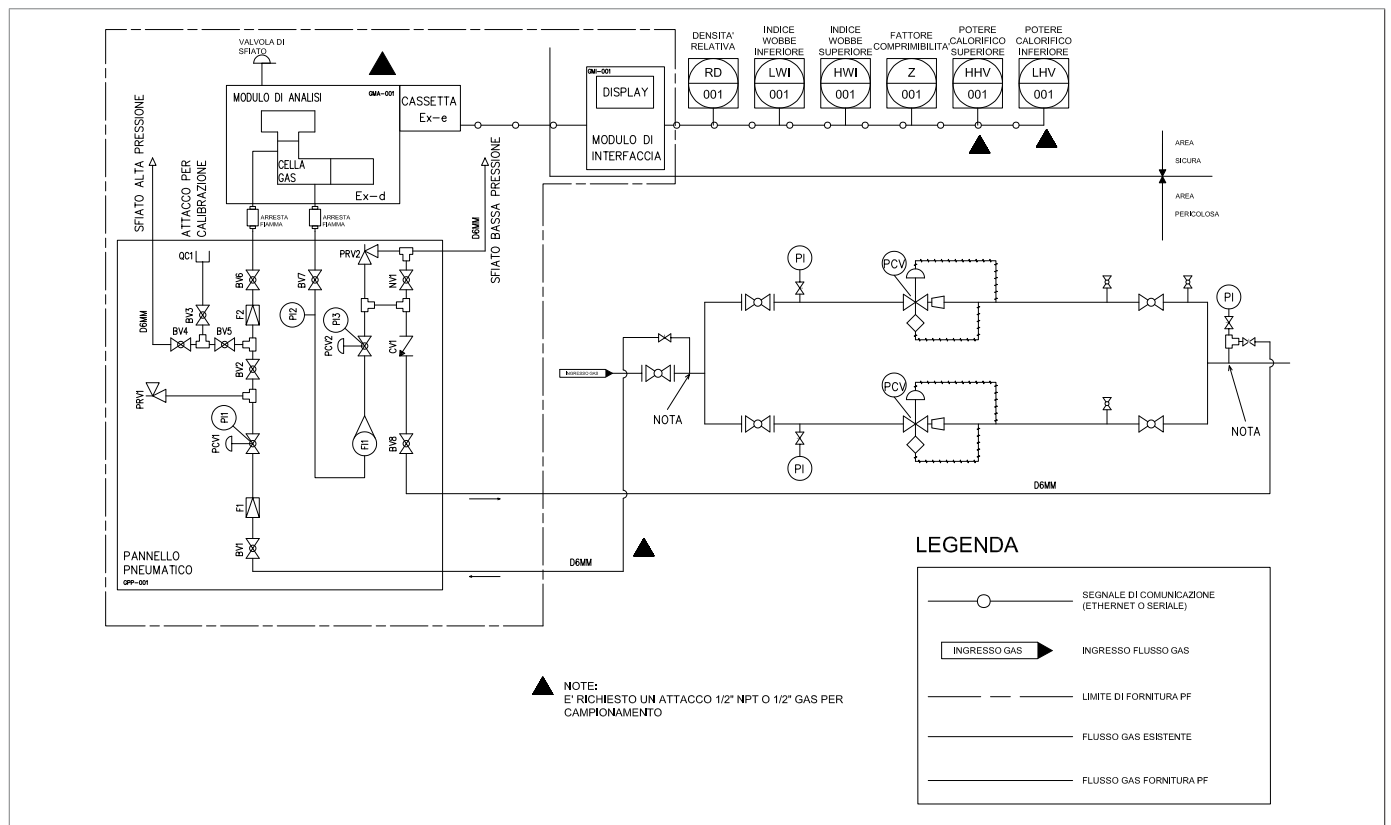

Fig. 7.34. Type 1 P&ID configuration of the acquisition module

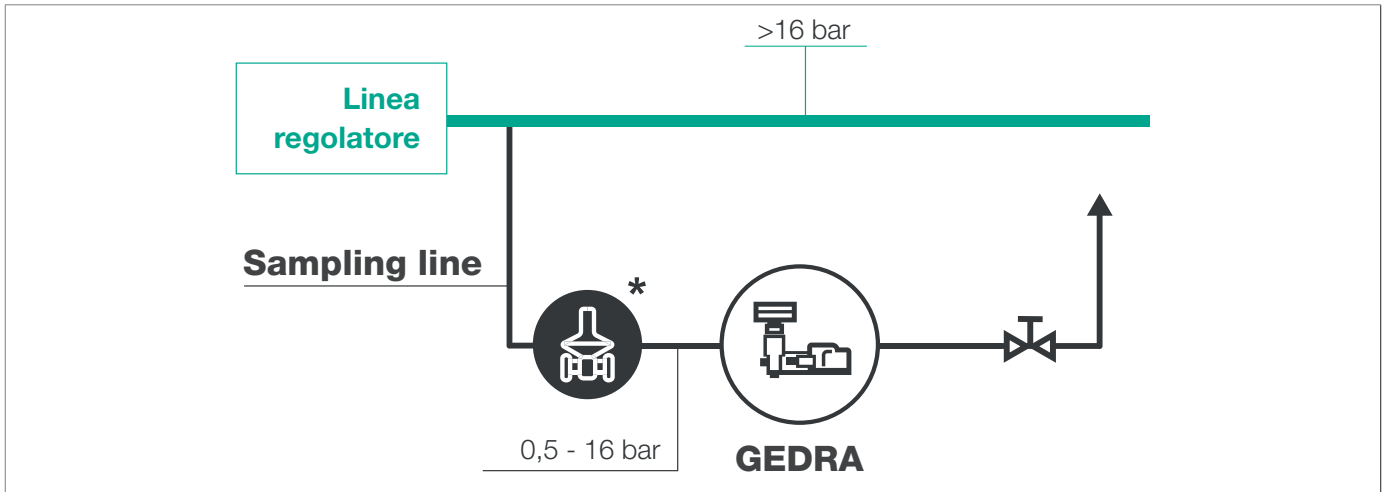

Fig. 7.35. Type 2 configuration of the acquisition module

Below is a typical representation of the P&ID (Piping and Instrument Diagram) for type 1 configuration of the acquisition module.

As shown in the diagram, to avoid interrupting the gas flow in the case of existing cabins, identify two gas sampling points upstream of the adjustment section, immediately after the filters (if present). If the adjustment section is not present, the gas sampling points must be identified upstream of the measuring section.

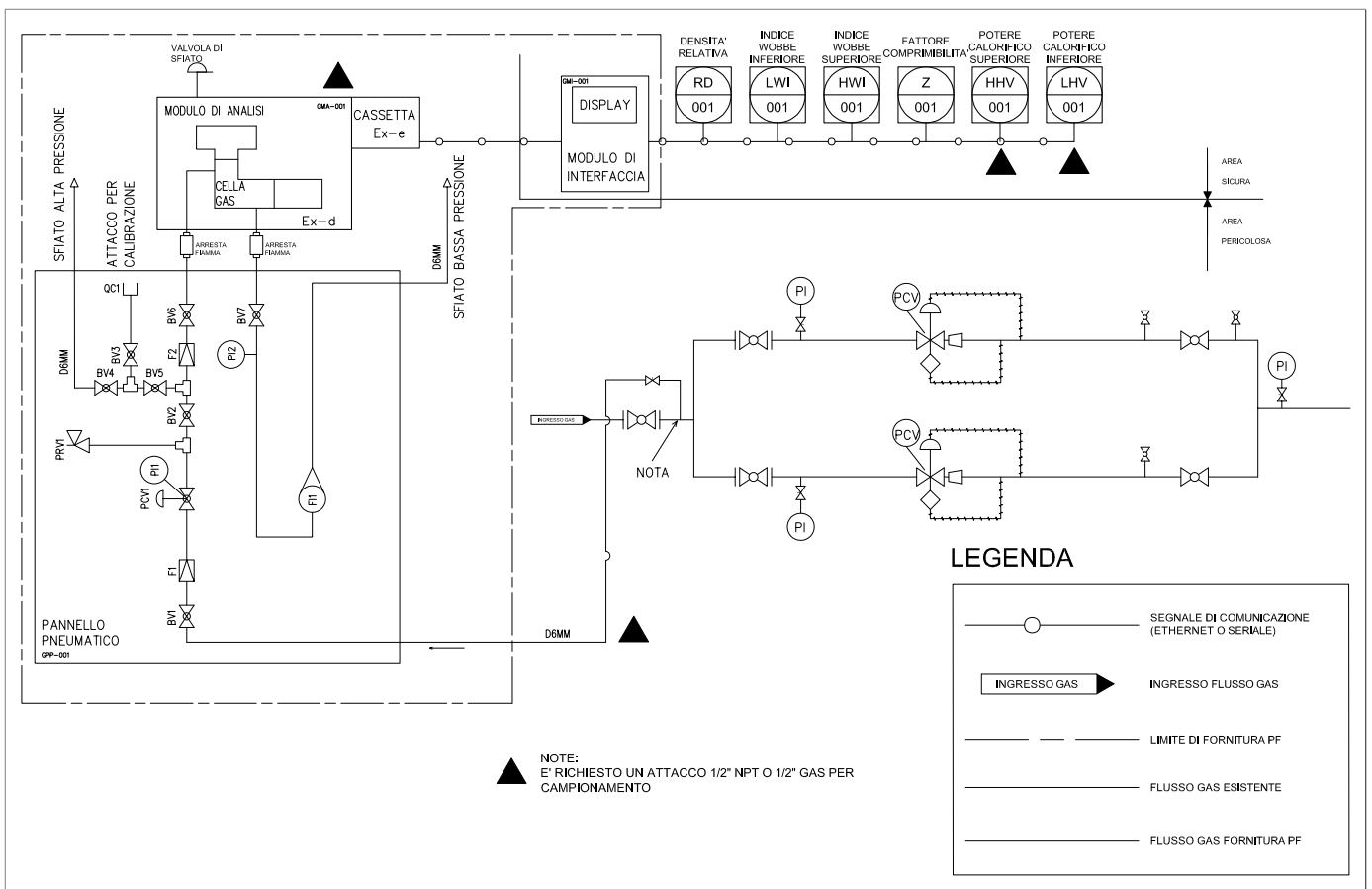

Fig. 7.36. Type 2 P&ID configuration of the acquisition module

7.7 - INSTALLATION PROCEDURE

7.7.1 - PRELIMINARY OPERATIONS

Identify:

- identify the sampling point at the pressure gauges (upstream of the adjustment section and possibly downstream of the filters present in the cabin. This will avoid the possible presence of particulate matter inside GEDRA). In the case of a cabin without adjustment, only one sampling point must be identified
- a re-injection point (placed downstream of the adjustment section and before the measurement section, so as not to bypass the cabin measurement), in the event of absence of adjustment the emission into the atmosphere will be carried out (configuration type 2, Fig. 7.35 and Fig. 7.36)
- the area where the hole is to be made to pass the cables between the safe and dangerous areas
- the acquisition module mounting area in the safe zone
- the field display mounting area in the hazardous area
- the area where the vent pipe passes out of the cabin

In case of metrological application:

- check the presence of the “anti-tampering” seals in the Ex-d box of the acquisition module
- be in possession of the ACCREDIA certified sample gas cylinder to carry out the verification operation required by the UNI 9167-3 standard

7.7.2 - EQUIPMENT INSTALLATION PROCEDURE

GEDRA is composed of two modules:

- **Acquisition module (AM):** analysis module installed in a hazardous area, consisting of two modules:
 - Ex-d boxes containing components subject to metrology;
 - pneumatic panel.

The acquisition module can be installed on:

- indoor frame (Fig. 7.37). This type of frame requires fixing to the ground using 3 M10 bolts;
- wall (Fig. 7.38, Fig. 7.39). This type of application requires wall fixing at the top of the Exd enclosure and at the bottom of the pneumatic panel;
- indoor frame (Fig. 7.40). This type of frame requires fixing to the ground using bolts.



Fig. 7.37. Indoor frame installation

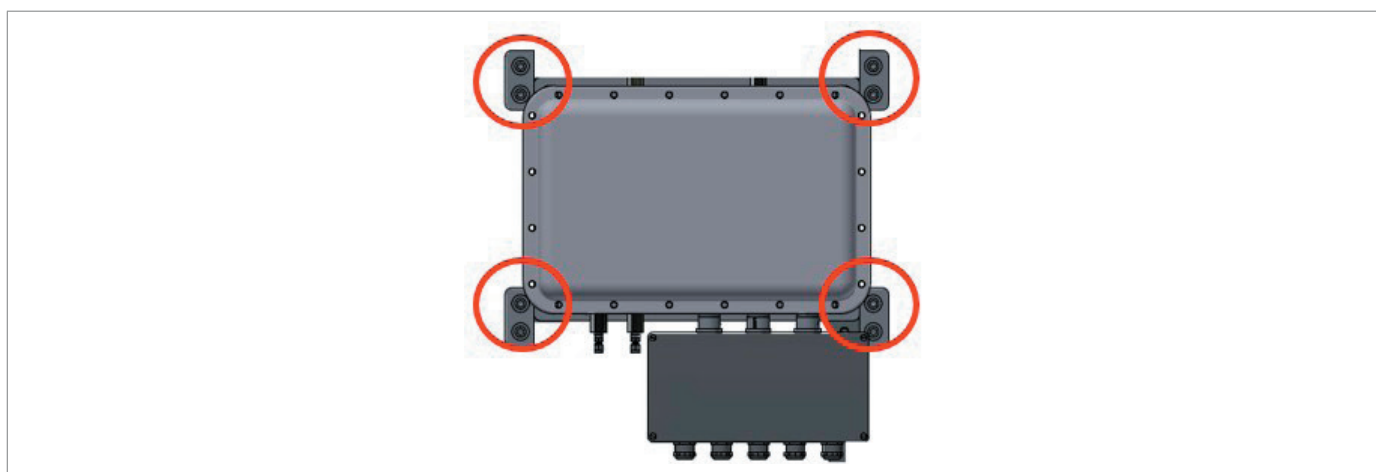

Fig. 7.38. Wall installation of the acquisition module (analysis module)

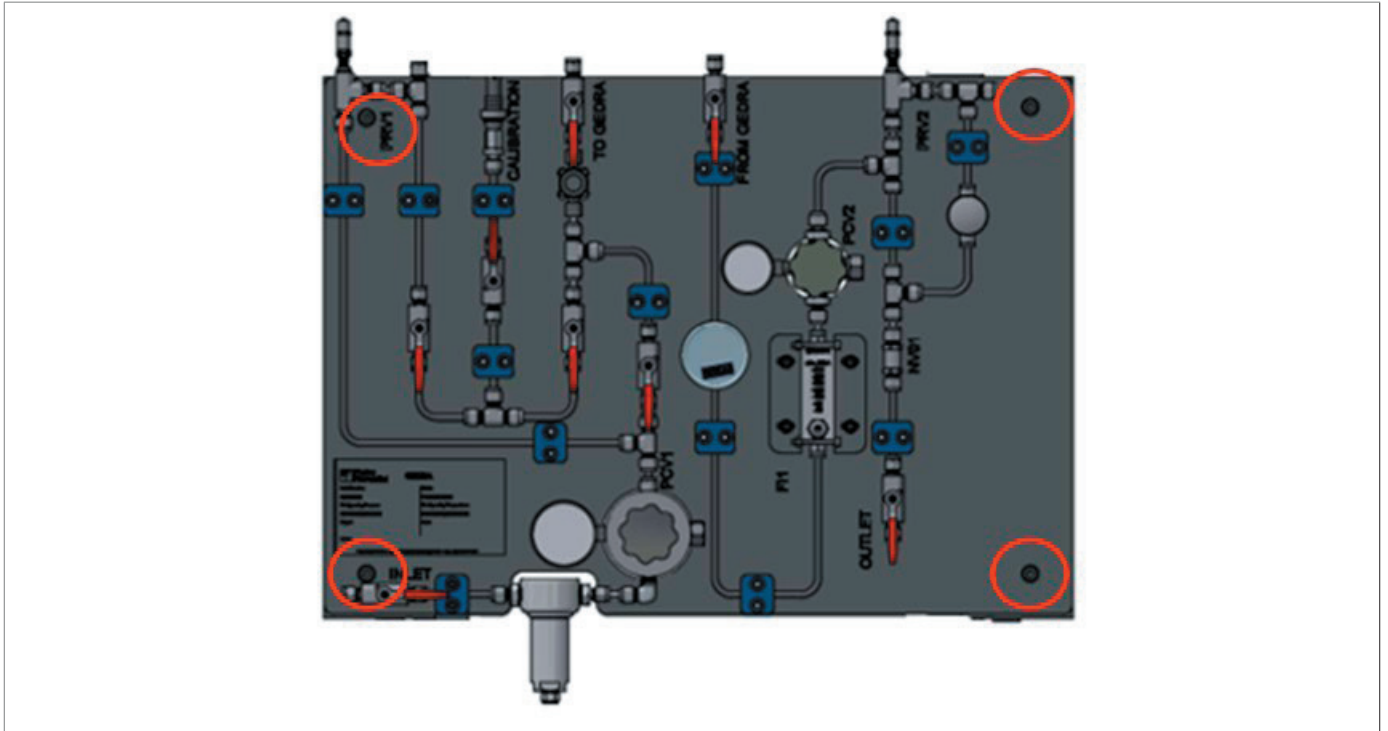

Fig. 7.39. Wall installation of the acquisition module (pneumatic panel)

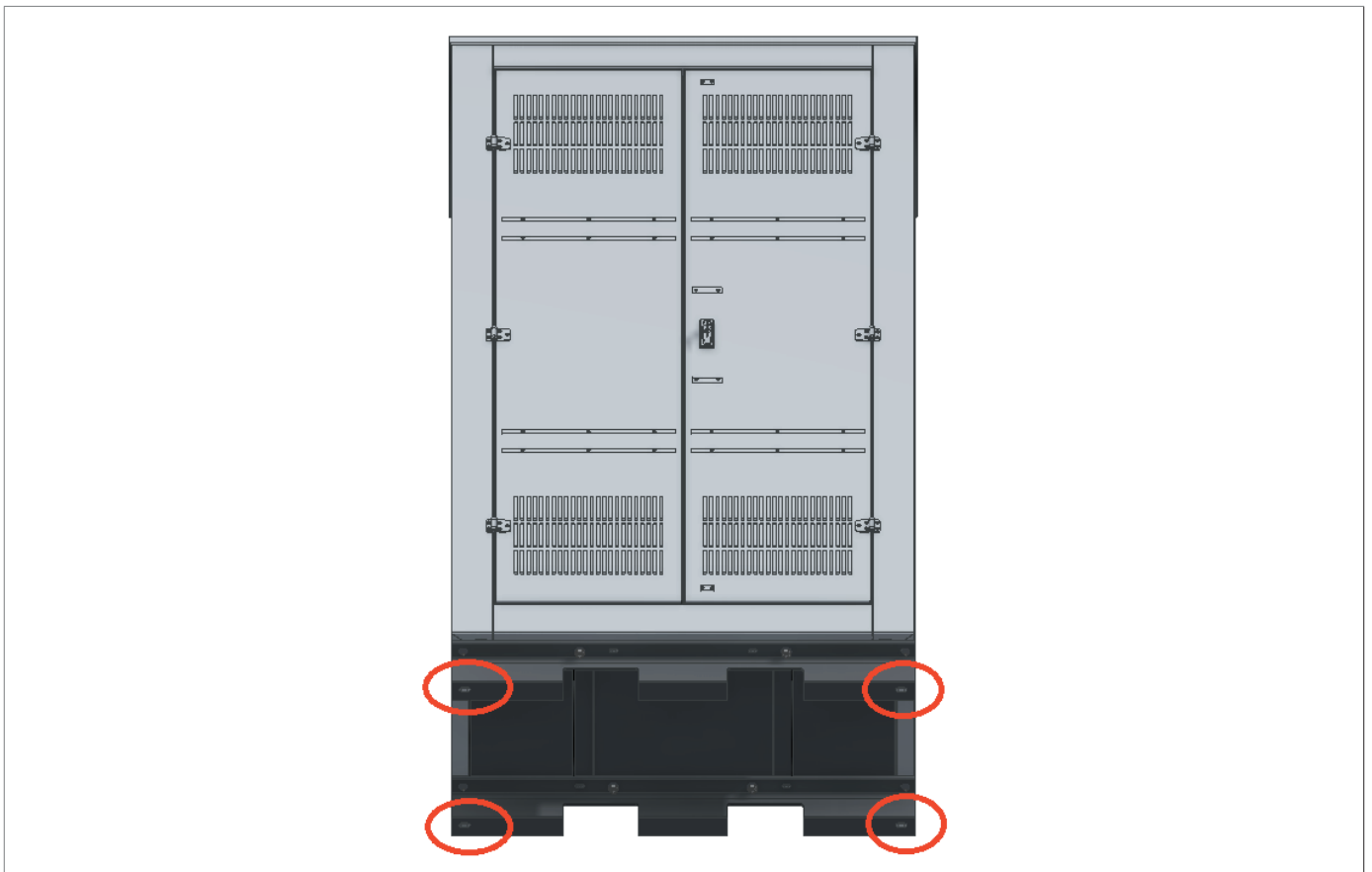

Fig. 7.40. Outdoor frame installation

- Field display (IM), if installed: touch screen graphic display installed in a safe area. The module must be fixed to the wall using the 4 brackets (Fig.7.41).

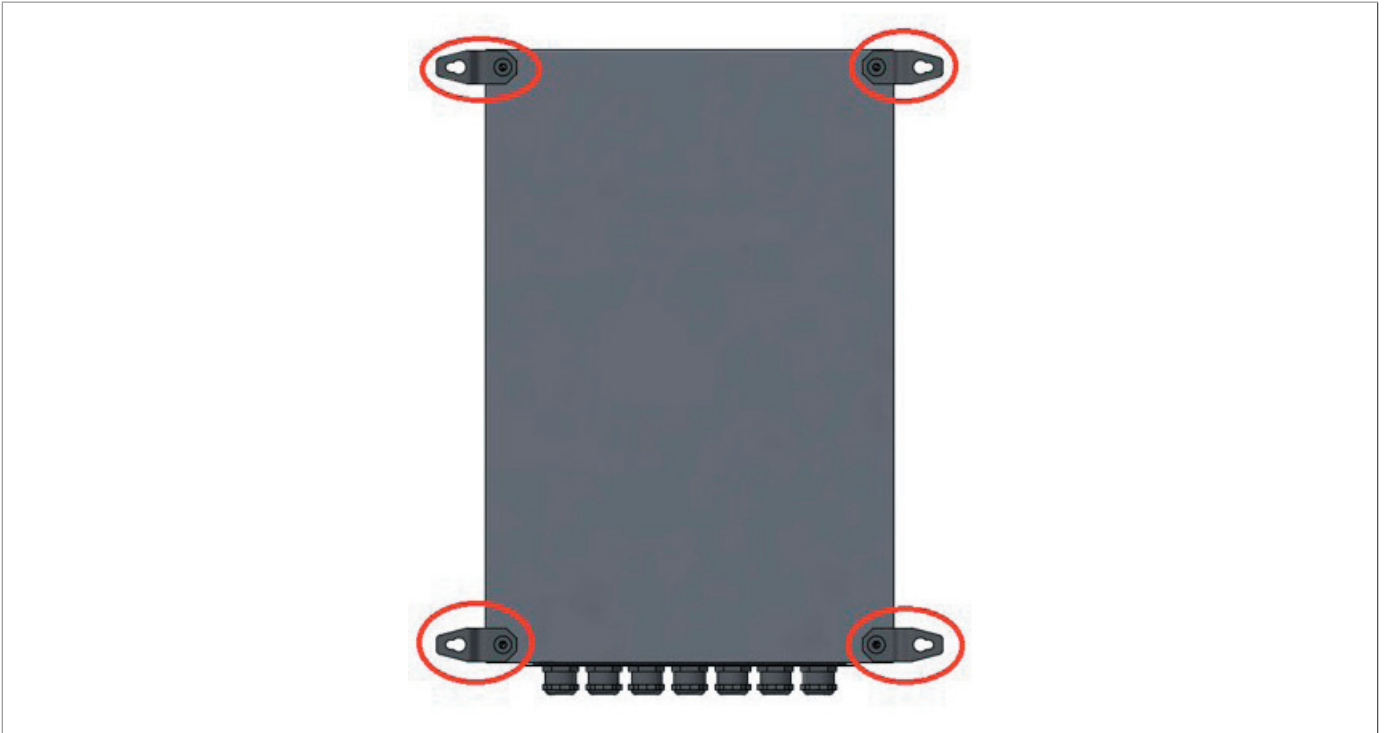

Fig. 7.41. Field display installation

7.7.3 - INSTALLATION OF THE ACQUISITION MODULE FOR HAZARDOUS AREAS

The field activity involves installing the indoor and/or outdoor frame and fixing it to the ground with 3 anchors. If the frame is not present, fix the Exd enclosure and the pneumatic panel to the wall.

Identify the two gas sampling points ($\frac{1}{2}$ " NPT or $\frac{1}{2}$ " GAS inlets) in the two measuring lines upstream of the adjustment section (at the fork in the main line).

At both selected sampling points, install the sampling probe (if applicable), a T-fitting on the selected gauge port and a $\frac{1}{4}$ " NPT valve. The T-fitting on the upper side will be connected to the pressure gauge, on the lower side to the probe (if present), alternatively to the pipe fitting, and to the $\frac{1}{4}$ " NPT valve which helps to open or close the flow in the pneumatic panel. Add a T-fitting to connect the two tubes used for sampling.

The following image shows the connection area of the 6 mm diameter SS316 stainless steel sampling tube, used for sampling and re-injecting the gas into the pipeline connected to the acquisition module.

The connection points for the sampling tube are listed below. The inlet pipe must be connected on the left side (indicated in the figure as "nozzle"), while the pipe intended for re-injection into the cabin duct must exit on the right side.

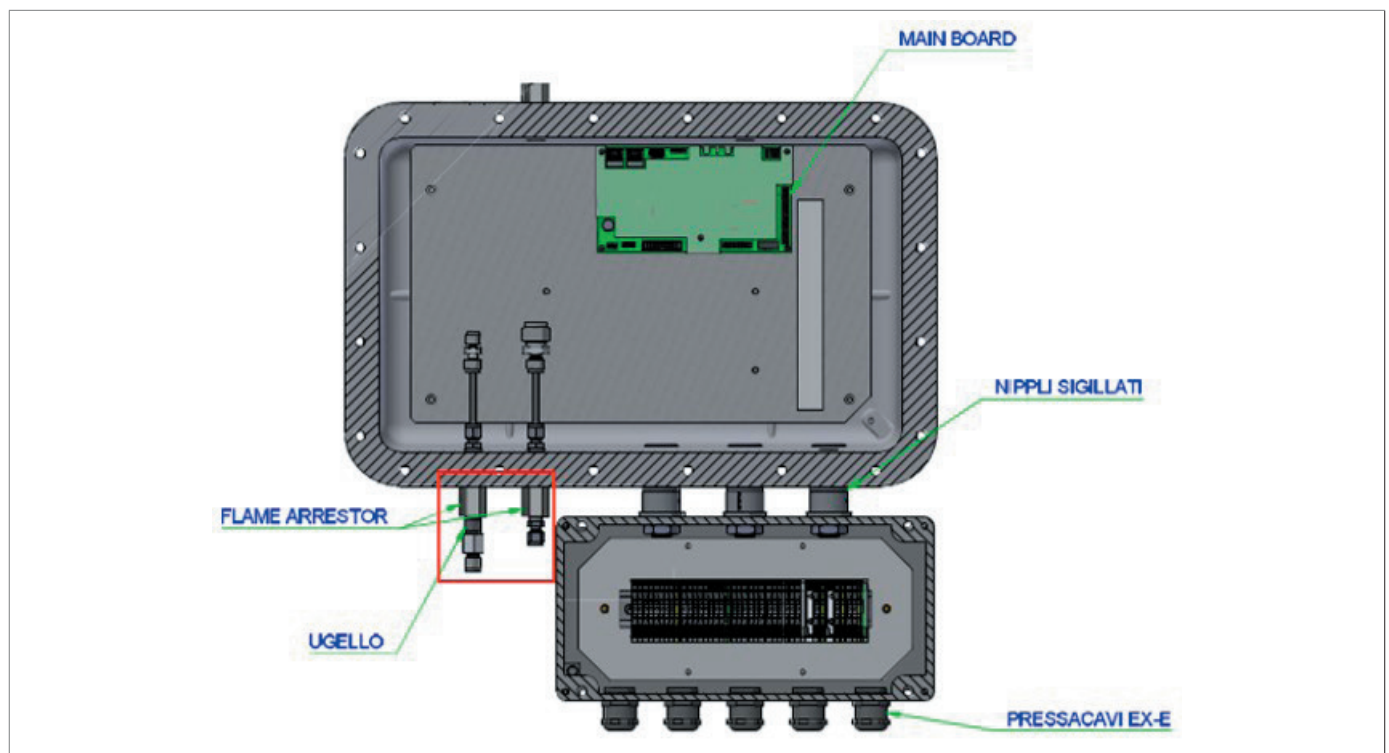

Fig. 7.42. Connecting the sampling tube to the acquisition module

The installation operation is carried out on both lines, stopping them alternately, thus avoiding interrupting the gas supply to the cabin.

Once the gas sampling connection has been made, the re-injection point must be connected. Post-analysis gas re-injection must be carried out downstream of the adjustment using an existing outlet in the pipeline. A T-fitting and a $\frac{1}{4}$ " NPT valve will need to be added. The tube connecting the $\frac{1}{4}$ " NPT valve to the pneumatic panel of the acquisition module is made of SS316 with a diameter of 6 mm.

Next, perform the following tasks:

1. Lay the cables in dedicated conduits to connect the analysis module (MA, dangerous area) with the field display (MI, safe area). Application of black flame-resistant sealant to isolate the safe area from the dangerous area.
2. Wiring of Exe terminal block cables (integrated with MA) according to the wiring diagram in a hazardous area.

7.7.4 - INSTALLATION OF THE PNEUMATIC PANEL IN A HAZARDOUS AREA

The pneumatic panel (Fig. 7.43) consists of:

- Gas inlet: connect this inlet to the pipe upstream of the adjustment section.
- Gas outlet: connect this outlet to the pipe downstream of the cabin adjustment section.
- Gas input to the GEDRA acquisition module: the following gas is sent to the GEDRA acquisition module for analysis.
- Gas output from the GEDRA acquisition module: the gas analyzed by the acquisition module is sent to the pneumatic panel.
- High pressure vent: high pressure vent outlet.
- Low pressure vent: low pressure vent outlet.

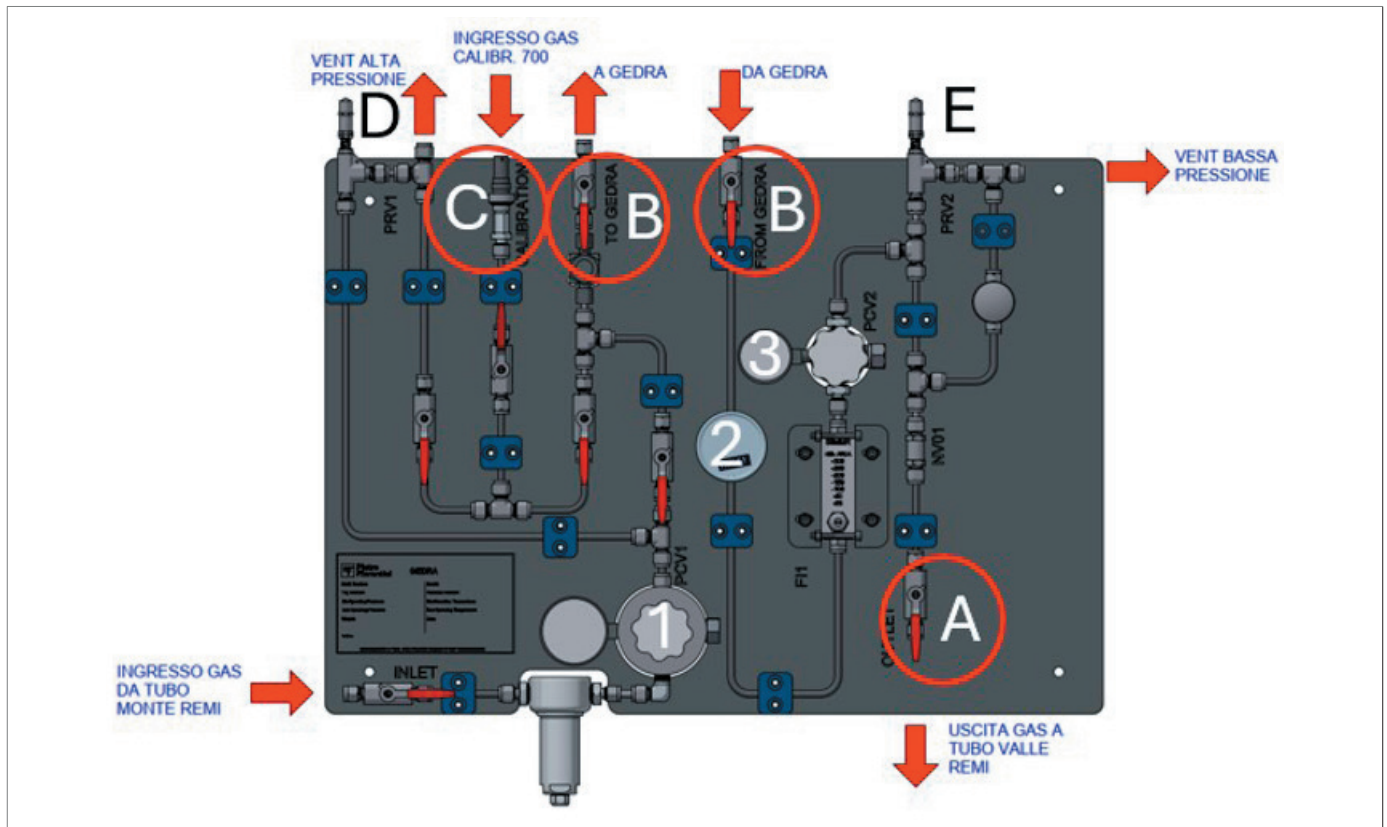

Fig. 7.43. Pneumatic panel diagram

The pneumatic tightness test of the pneumatic panel required by current legislation must be carried out.

Before proceeding with the pneumatic tightness test of the pneumatic panel, check that:

- the drain valve (indicated by the letter A in the image above) is closed;
- valves from e to GEDRA (indicated by the letter B in the image above) are open;
- the calibration section valve (indicated by the letter C in the image above) is open.

The pneumatic leak test is carried out using a control gas cylinder, applying the product to the suspect areas. If there are leaks, bubbles or foam may appear, which indicates the need for intervention.

Once the pneumatic test is completed, carry out the following activities:

- Adjust the upstream PSV set to the desired pressure.
- Adjust the inlet pressure to the GEDRA analysis cell using the regulator installed on the pneumatic panel.
- Adjust the downstream PSV set to the desired pressure.
- Adjust the downstream pressure (so you can re-inject it).

7.7.5 - FIELD DISPLAY (IM) INSTALLATION FOR SAFE AREA

The actions to be carried out regarding the field display installation are the following:

1. MI terminal block cable wiring in safe area.

The cables connecting the acquisition module and the field display are:

- 1 multi-core cable for the 4 RS485 serial communications.
 - 2 Ethernet cables.
 - 1 x 24 VDC power cable.
 - 1 alarm cable (if required).
2. Install on the wall using the eyelets provided.
 3. MI power test and display powering on check.
 4. MA power supply test and communication check through MI.





The customer must provide power for the entire system via a circuit breaker. In case of metrological application:

- metrological verification with sample gas cylinder;
- if passed: application of metrological seals on MA and MI serial ports intended for flow computers.

PAGE INTENTIONALLY LEFT BLANK

8 - CONFIGURATION

8.1 - SAFETY REQUIREMENTS FOR CONFIGURATION

Configuration	
Operator qualification	<ul style="list-style-type: none"> Specialised technician. Installer.
PPE required	<div style="display: flex; align-items: center;">      </div> <div style="background-color: #f4a460; padding: 5px; margin-top: 5px;"> <p>WARNING!</p> </div> <p>The PPE listed in this table is related to the risk associated with the equipment. For the required PPE to protect against risks associated with the workplace, installation or operating conditions, please refer to:</p> <ul style="list-style-type: none"> the regulations in force in the country of installation; <u>any information provided by the Safety Manager at the installation facility.</u>

Tab. 8.32.

8.2 - EQUIPMENT CONFIGURATION

NOTICE!

The configuration of the equipment must be carried out by authorized and trained personnel.

NOTICE!

The field configuration of the device can be performed remotely from the customer's control centre, always using the application protocol, as specified by the UNI 11885 standards and the SNAM protocol, or according to the user interface instructions.

8.3 - VERIFY CORRECT CONFIGURATION

The installation of seals is the responsibility of the installer and their qualified personnel. The software configuration is performed by appointed and qualified personnel during the installation phase.

8.4 - COMMISSIONING ACTIVITIES

After installing the GEDRA, it is necessary to perform a functional check according to the steps below:

- **Check the supply voltage:** check that the value is correct and stable
- **Adjust gas pressure and flow:** make sure the parameters are set correctly for the power supply.
- **Configure serial interface ports:** check communication with the flow computer and other connected devices, such as any modems
- **Set the analysis frequency:** perform the configuration from the field display (if available) or remotely
- **Check for alarms:** make sure the system is free of error reports
- **Evaluate the accuracy of the following parameters,** comparing them with the certificate of the certified sample gas cylinder:
 - Higher Calorific Value (HCV).
 - Lower Calorific value (LCV).
 - Relative density.
 - Carbon Dioxide (CO₂) content.
 - Compressibility factor (Z).

The verification procedure (in the case of installation in Italy), as indicated by regulation UNI 9571-2, requires a 10-minute analysis: the data collected in the first 5 minutes must be discarded. The parameters to be compared with those indicated in the cylinder certificate are calculated on the results of the following minutes.

The verification as indicated by UNI 9571-2 requires carrying out the analysis for a period of 10 minutes with a 5-minute delay and the parameters mentioned above are calculated on the remaining analyses.

NOTICE!

Before proceeding with connecting the sample gas cylinder, carry out the operations in the user interface indicated in chapter 5.

The periodic verification procedure includes the following activities:

1. Perform operations in the user interface.
2. Close the pneumatic panel valve, corresponding to the gas inlet from the remi upstream pipe.
3. Check the opening of the gas outlet valve on the downstream remi pipe (in the following image the valve to be closed is circled in red and the valve to be kept open is circled in yellow).
4. Connect the sample gas cylinder to the pneumatic panel at the calibration gas inlet (circled in green in the image below).
5. Once the sample gas cylinder is connected, select the “START” button in the user interface and follow the instructions on the display.
6. Once the periodic verification is complete, remove the connection between the cylinder and the pneumatic panel.
7. Open the previously closed valves.

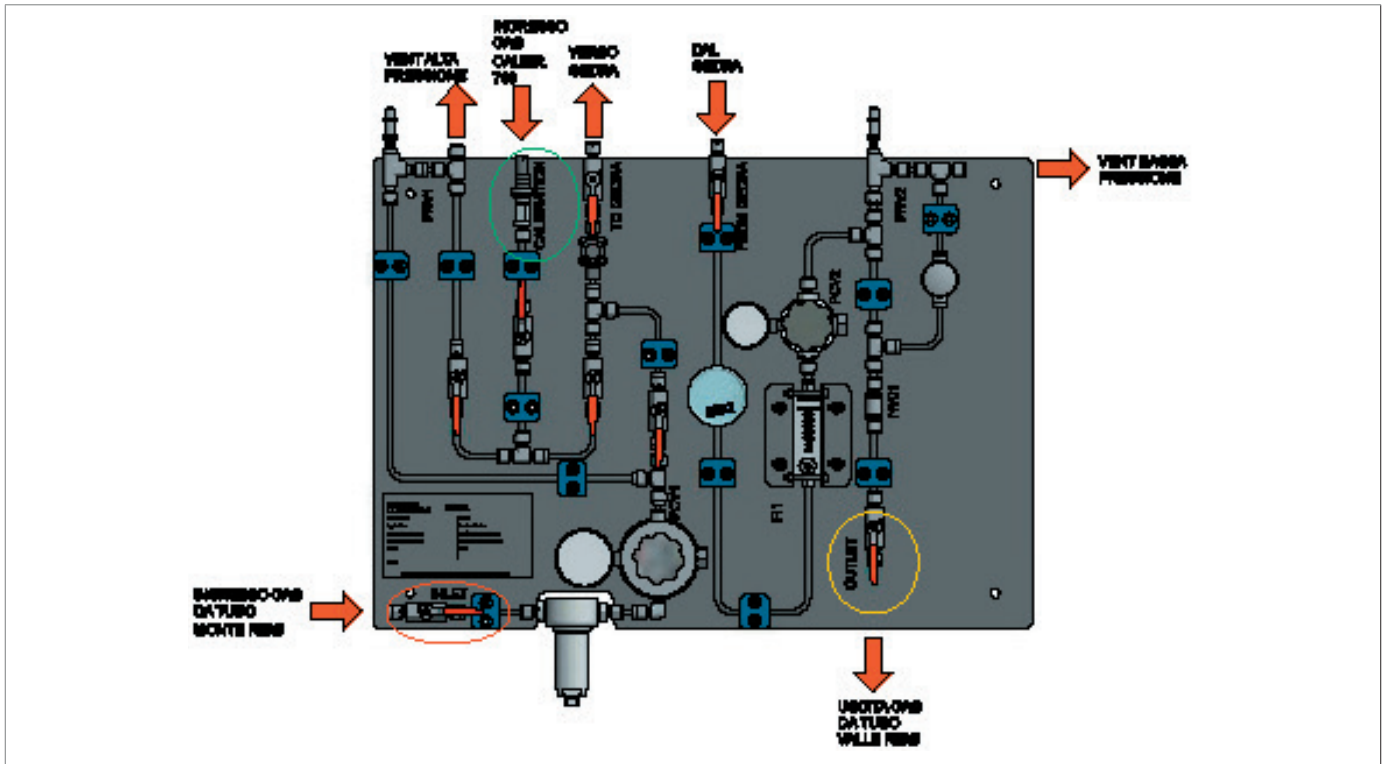

Fig. 8.44. Panel GEDRA, front

PAGE INTENTIONALLY LEFT BLANK

9 - MAINTENANCE AND FUNCTIONAL CHECKS

9.1 - GENERAL WARNINGS

HAZARD!

- Maintenance work must be carried out by qualified personnel trained on safety in the workplace and authorised to carry out equipment-related activities.
- Repair or maintenance work not provided for in this manual may be carried out only if approved by PIETRO FIORENTINI S.p.A.. No liability for personal injury or damage to property can be attributed to PIETRO FIORENTINI S.p.A. for work other than that described or performed in a manner other than indicated.

HAZARD!

Special maintenance:

- requires extensive and specialised knowledge of the machines, operations required, risks involved and correct procedures to operate safely;
- must be provided by qualified, trained and authorised technicians.

WARNING!

In case of doubt, do not perform any work.

Contact PIETRO FIORENTINI S.p.A. for the necessary clarifications.

WARNING!

Any tampering with the devices mounted on the Ex-d box or the Ex-e box of the device is not permitted. No replacement of glands, removal of flame arrestors or breathing devices may be performed. No further drilling is permitted.

NOTICE!

Before starting maintenance on the equipment, it is advisable to make sure that the authorised operator has:

- the necessary equipment;
- appropriate spare parts.

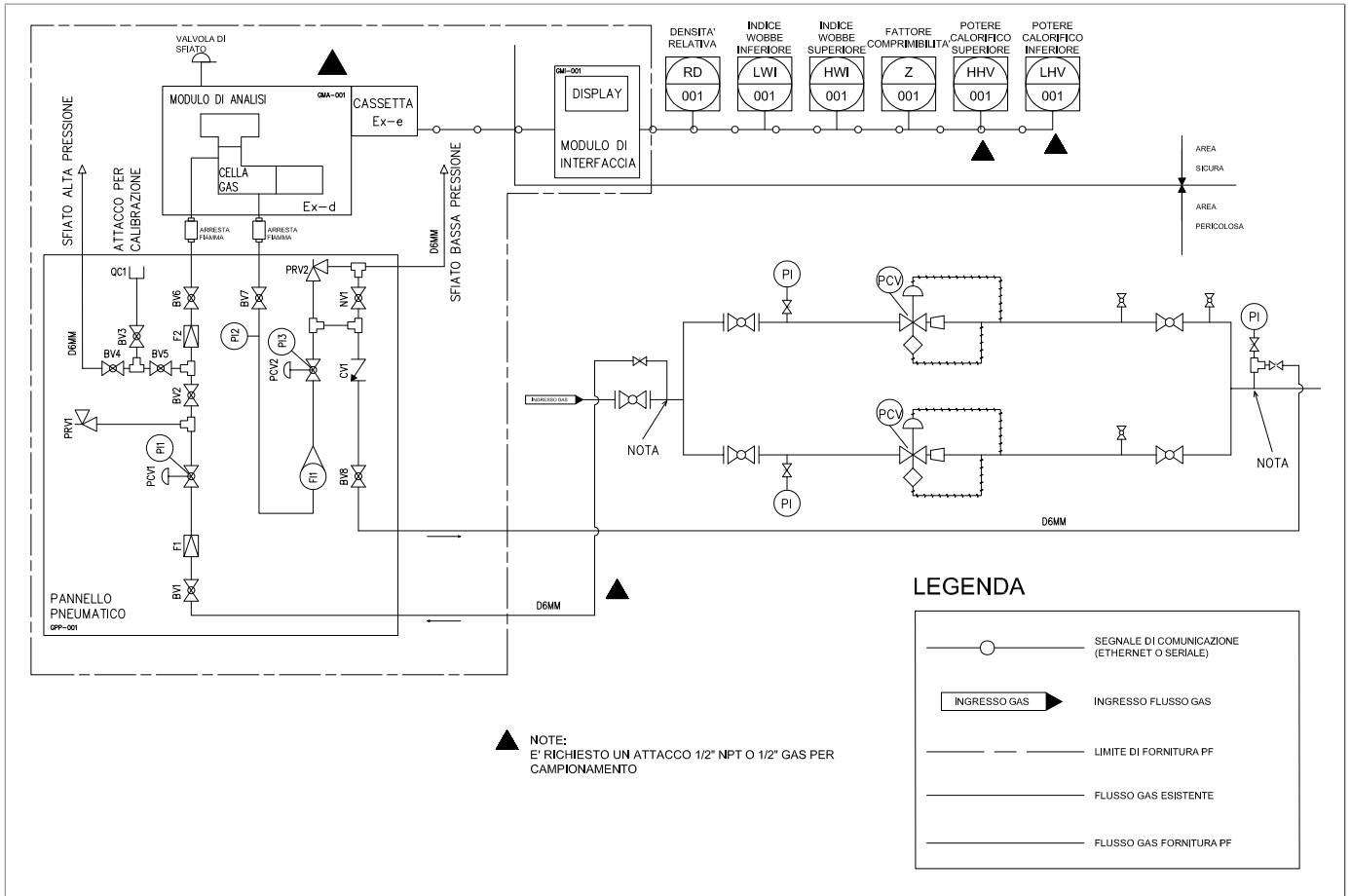

Fig. 9.45. Type 1 P&ID configuration of the acquisition module

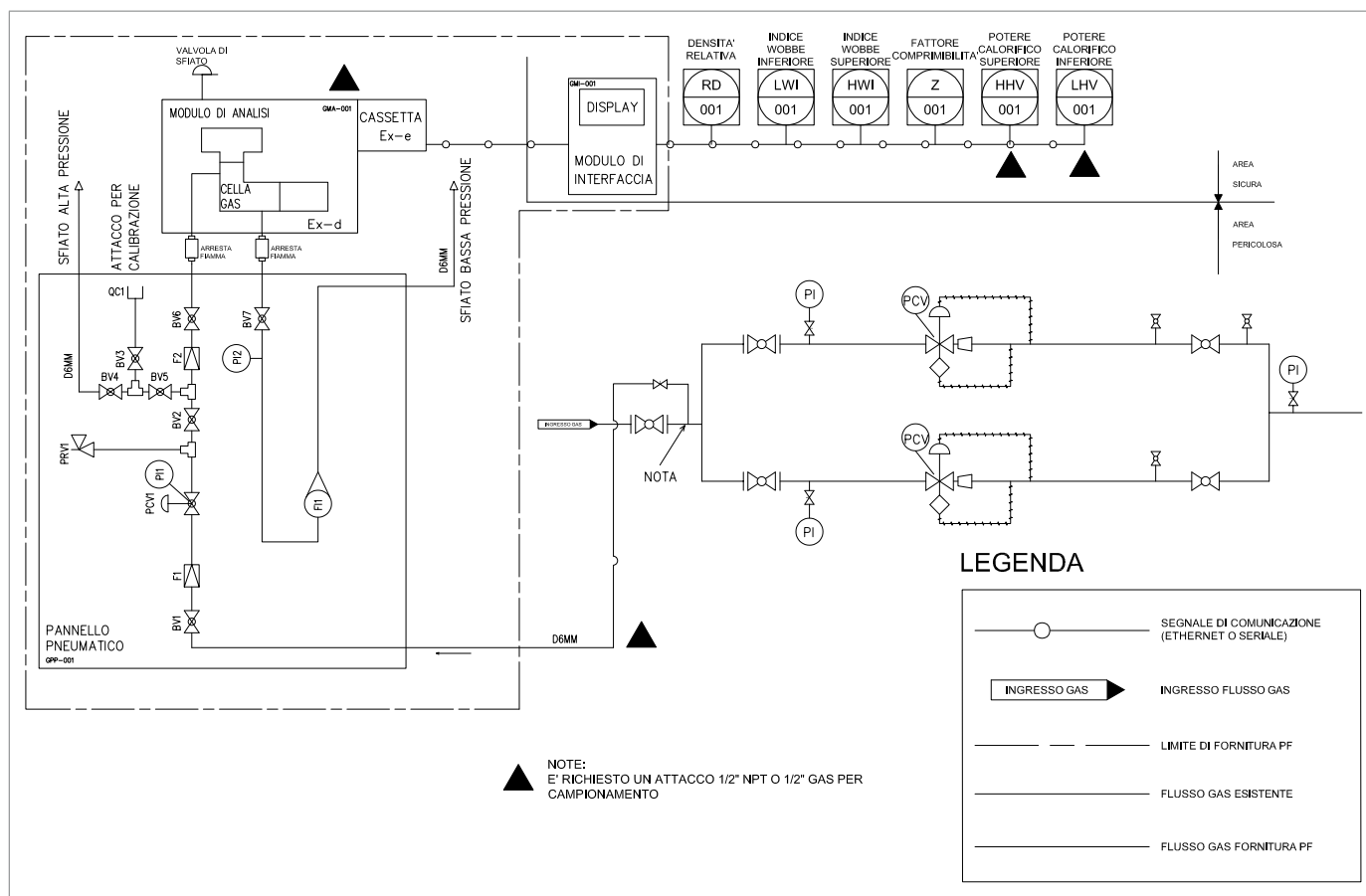

Fig. 9.46. Type 2 P&ID configuration of the acquisition module

In case of anomalies detected in the equipment, which require its removal and replacement from the field, operate as described in Tab. 9.33:

Step	Action
1	Turn off the power supply to the equipment (HS-001)
2	Close the downstream shut-off valve of the equipment (BV8)
3	Close the upstream shut-off valve of the equipment (BV1)
4	Proceed with equipment maintenance

Tab. 9.33.

The equipment maintenance operations are divided, from an operational point of view, into two main categories:

Commissioning and maintenance operations	
Routine maintenance	<p>All those operations that the operator must preventively carry out to ensure proper operation of the device over time.</p> <div style="border: 1px solid blue; padding: 5px;"> <p>NOTICE!</p> <p>Replacing filter cartridges.</p> </div>
Special maintenance	<p>All those operations to be carried out by the operator when the equipment requires them.</p>

Tab. 9.34.

9.2 - ROUTINE MAINTENANCE

9.2.1 - FILTER REPLACEMENT PROCEDURE

Filter replacement	
Operator qualification	<ul style="list-style-type: none"> Specialised technician. Maintenance Technician.
PPE required	 <p>WARNING!</p> <p>The PPE listed in this table is related to the risk associated with the equipment. For the required PPE to protect against risks associated with the workplace, installation or operating conditions, please refer to:</p> <ul style="list-style-type: none"> the regulations in force in the country of installation; any information provided by the Safety Manager at the installation facility.
Equipment required	<ul style="list-style-type: none"> Adjustable wrench μm filter compass wrench

Tab. 9.35.

ATTENTION!

All operations must be carried out:

- away from heat sources,
- in a place protected from bad weather
- as far away as possible from sources of water that could react if it came into contact, even accidentally, with the lithium contained inside the batteries.

ATTENTION!

Operators should not wear jewellery or metal ornaments (rings, necklaces, bracelets and earrings) that may come into contact with electronic components and/or battery terminals to avoid potential short circuits.

ATTENTION!

The fire extinguishers to be used in the event of a fire must be of class D as they are effective in extinguishing fires in the presence of lithium.

To replace the 5/0.5 μm filter cartridge (referring to Fig. 9.47), proceed as described in Tab. 9.36:

Step	Action
1	Turn off the power supply to the equipment (HS-001)
2	Close the downstream shut-off valve of the equipment (BV8)
3	Close the upstream shut-off valve of the equipment (BV1)
4	Relieve pressure in the circuit using the pneumatic panel valves (BV4, NV1)
5	Unscrew the metal cover of the filter (see filter diagram below) (F1, F2)
6	Replace filter element
7	Screw the metal filter cover
8	Reopen shut-off valves and restore power (BV8, BV1, HS-001)

Tab. 9.36.

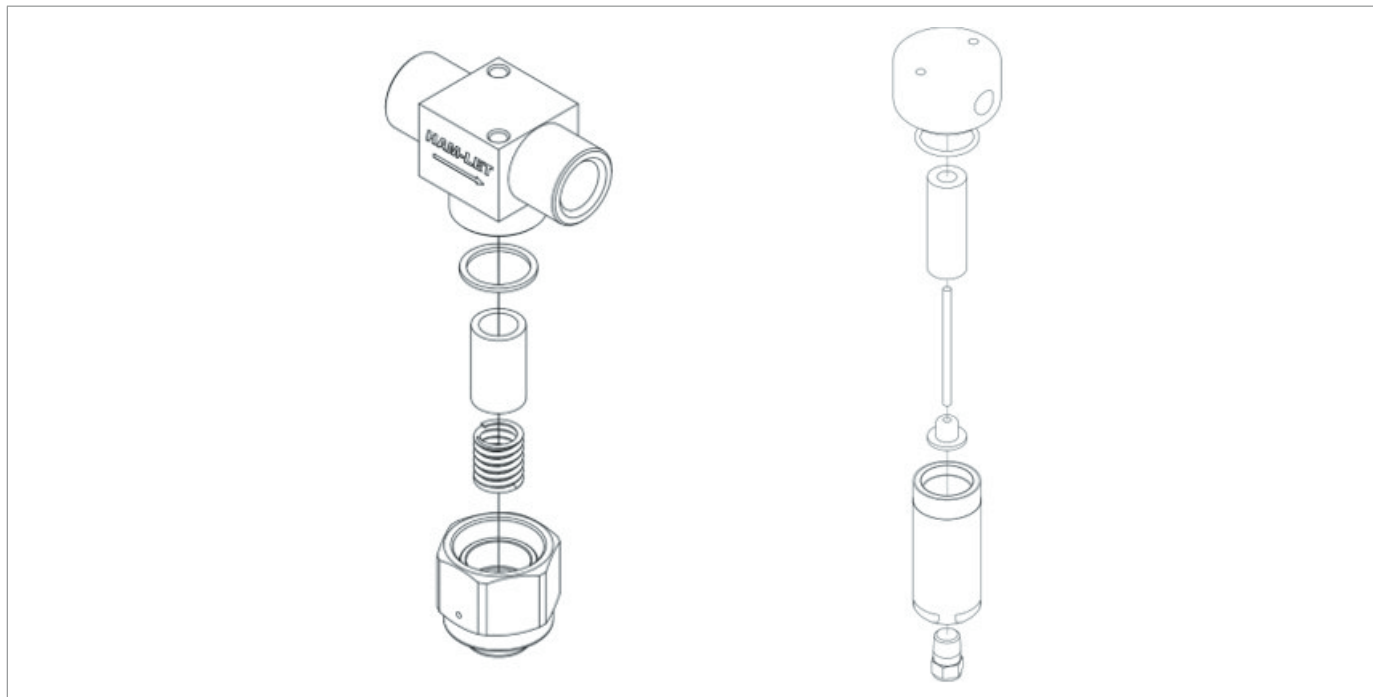

Fig. 9.47. Filter replacement

9.1 - PERIODIC VERIFICATION PROCEDURE

The periodic verification includes the verification of the following parameters:

- Higher Calorific Value (HCV)
- Lower Calorific value (LCV)
- Compressibility factor (Z)
- Relative density

Periodic verification is mandatory in the case of fiscal application with frequency as indicated in the OIML R140 metrological certification. In case of non-fiscal application, it is recommended every two years.

This chapter contains the operational details for the periodic verification, while chapter 5, paragraph "USER PROFILE", indicates the activities to be carried out in the user interface during the periodic verification. We recommend reading both chapters before proceeding with the activity.

To carry out the periodic verification it is necessary to have a certified sample gas cylinder (in the case of installation in Italy, a cylinder that meets the following requirements according to UNI 9167-3 is required:

The following parameters can be changed in the Periodic verification settings section:

- HCV (Higher Calorific Value) values: 37.3-38.1MJ/Sm³, 38.9-40.1MJ/Sm³ (at reference conditions T₁=15°C, T₂=15°C, p=1.01325 bara)
- Molar composition of carbon dioxide: CO₂ > 1% mol
- Molar composition of hydrogen: H₂ >1%mol

The verification procedure (in the case of installation in Italy), as indicated by regulation UNI 9571-2, requires a 10-minute analysis: the data collected in the first 5 minutes must be discarded. The parameters to be compared with those indicated in the cylinder certificate are calculated on the results of the following minutes.

NOTICE!

Before proceeding with connecting the sample gas cylinder, carry out the operations in the user interface indicated in chapter 5.

The periodic verification procedure includes the following activities:

1. Perform operations in the user interface
2. Close the pneumatic panel valve, corresponding to the gas inlet from the remi upstream pipe
3. Check the opening of the gas outlet valve on the downstream remi pipe (in the following image the valve to be closed is circled in red and the valve to be kept open is circled in yellow)
4. Connect the sample gas cylinder to the pneumatic panel at the calibration gas inlet (circled in green in the image below)
5. Once the sample gas cylinder is connected, select the “START” button in the user interface and follow the instructions on the display.
6. Once the periodic verification is complete, remove the connection between the cylinder and the pneumatic panel
7. Open the previously closed valves.

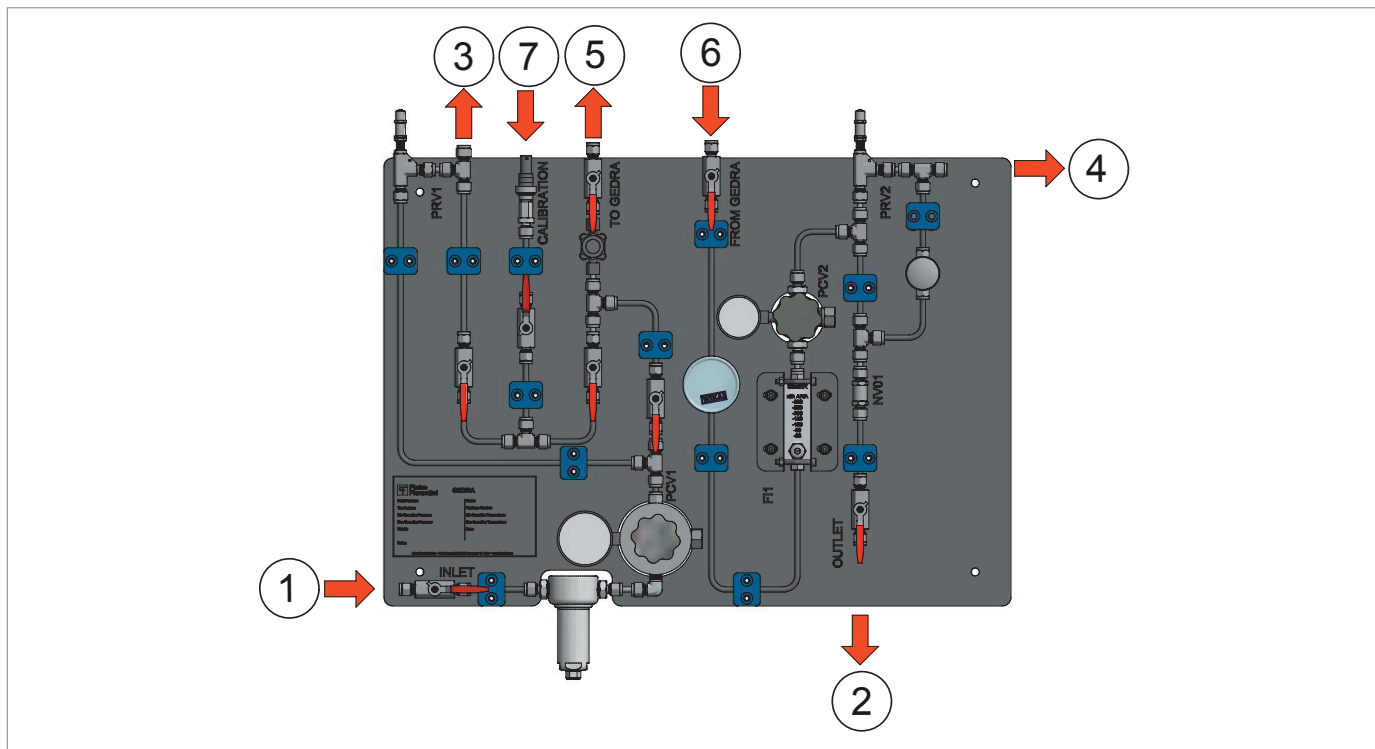

Fig. 9.48. Pneumatic panel

10 - TROUBLESHOOTING

Listed below are the cases (causes and tripping) that could occur in the form of malfunctions of various kinds over time. These situations depend on the conditions of the gas as well as on the natural ageing and wear of the materials.

10.1 - GENERAL WARNINGS

HAZARD!

Maintenance work must be carried out by qualified personnel:

- trained in workplace safety also based on the regulations in force in the place of installation of the work equipment;
- qualified and authorised to carry out activities related to the equipment.

WARNING!







Shall not be held liable for any damage to people and property due to PIETRO FIORENTINI S.p.A. actions:

- other than those described;
- performed according to methods other than those specified;
- carried out by unsuitable personnel.

NOTICE!

If an operating fault occurs and qualified personnel are not available for the specific intervention, call the Assistance Centre authorised by PIETRO FIORENTINI S.p.A.

10.2 - OPERATOR QUALIFICATION SPECIFICATION

Commissioning	
Operator qualification	<ul style="list-style-type: none"> • Mechanical maintenance technician; • Electrical maintenance technician; • Installer; • User technician.
PPE required	<div style="display: flex; align-items: center; gap: 10px;">      </div> <div style="background-color: #f4a460; padding: 5px; margin-top: 5px;">  WARNING! </div> <p>The PPE listed in this table is related to the risk associated with the equipment. For the required PPE to protect against risks associated with the workplace, installation or operating conditions, please refer to:</p> <ul style="list-style-type: none"> • the regulations in force in the country of installation; • any information provided by the Safety Manager at the installation facility.
Equipment required	Please refer to the chapter “7 - Installation”.

Tab. 10.37

10.3 - TROUBLESHOOTING PROCEDURES

For proper troubleshooting, proceed as follows:

- close the upstream and downstream shut-off valves;
- refer to the troubleshooting tables listed below.

11 - UNINSTALLATION AND DISPOSAL

11.1 - GENERAL SAFETY WARNINGS

HAZARD!



Make sure that there are no ignition sources in the work area set up to uninstall and/or dispose of the equipment.

WARNING!

Before proceeding with uninstallation and disposal, make the equipment safe by disconnecting it from any power supply.

11.2 - QUALIFICATION OF THE OPERATORS IN CHARGE

Uninstallation

Operator qualification	<ul style="list-style-type: none"> Installer.
PPE required	<div style="display: flex; align-items: center;">  </div> <div style="background-color: #f4a460; padding: 5px; margin-top: 5px;">  WARNING! </div> <p>The PPE listed in this table is related to the risk associated with the equipment. For the required PPE to protect against risks associated with the workplace, installation or operating conditions, please refer to:</p> <ul style="list-style-type: none"> the regulations in force in the country of installation; any information provided by the Safety Manager at the installation facility.
Equipment required	Keys to fix inlet and outlet connections fittings/connections of the equipment.

Tab. 11.38.

11.3 - UNINSTALLATION

To properly uninstall the equipment, proceed as specified in Tab. 11.39:

Step	Action
1	Close the valve upstream and downstream of the equipment.
2	Disconnect the upstream and downstream pipes from the equipment by unscrewing the fittings with adequate hand tools.
3	Remove the equipment. <div style="border: 1px solid blue; padding: 5px; margin-top: 10px;">  NOTICE! Seal the valves upstream and downstream of the equipment if: <ul style="list-style-type: none"> closing the system; the equipment is not replaced immediately. </div>

Tab. 11.39.

11.4 - INFORMATION REQUIRED IN CASE OF NEW INSTALLATION

NOTICE!

Should the equipment be reused after uninstallation, refer to chapters: "Installation" and "Configuration".

11.5 - INFORMATION REQUIRED IN CASE OF RE-INSTALLATION

NOTICE!

Should the equipment be reused after uninstallation, please refer to Chapter 7 "Installation".

11.6 - DISPOSAL INFORMATION

NOTICE!

- Proper disposal prevents damage to man and the environment and promotes the reuse of precious raw materials.
- Bear in mind that the regulations in force in the country where the system is installed must be complied with.
- Illegal or incorrect disposal involves the application of the penalties provided for by the regulations in force in the country of installation.

The equipment was manufactured with materials that can be recycled by specialised companies. To dispose of the equipment correctly, proceed as indicated in Tab. 11.40:

Step	Action
1	Set up a large work area free from obstacles where to safely dismantle the equipment.
2	Sort the various components by type of material for easier recycling through separate collection.
3	Send the materials obtained in Step 2 to a specialised company.

Tab. 11.40.

The equipment in any possible configuration consists of the materials described in Tab. 11.41:

Material	Disposal/recycling indications
Plastic	It must be dismantled and disposed of separately.
Steel	Disassemble and collect separately. It must be recycled through the specific collection centres.
Stainless steel	Disassemble and collect separately. It must be recycled through the specific collection centres.
Aluminium	Disassemble and collect separately. It must be recycled through the specific collection centres.
Electronic components	Disassemble and collect separately. It must be recycled through the specific collection centres.
Lithium batteries	Refer to paragraph 10.7.1 "Disposing of the batteries".

Tab. 11.41.

NOTICE!

The above materials refer to standard versions. Different materials can be provided for specific needs.

12 - RECOMMENDED SPARE PARTS

12.1 - GENERAL WARNINGS

NOTICE!

If spare parts not recommended are used, PIETRO FIORENTINI S.p.A. their declared performance cannot be guaranteed.

It is recommended to use original spare parts PIETRO FIORENTINI S.p.A.

PIETRO FIORENTINI S.p.A. shall not be held liable for any damage caused by using non-original parts.

12.2 - HOW TO REQUEST SPARE PARTS

NOTICE!

For specific information, please refer to the sales network of PIETRO FIORENTINI S.p.A.

12.3 - SPARE PARTS LIST

Spare part name	Quantity (for a GEDRA)	Metrological impact	Recommended replacement frequency	Notes
5 µm filters	1	No	<ul style="list-style-type: none"> If there is a cabin filter, replace 5 µm filter every 1 year If there is no cabin filter, replace 5 µm filter every 3 months 	The frequency of replacing the 5 µm filter depends on whether the filter is present or not in the cabin.
0.5 µm filter	1	No	<ul style="list-style-type: none"> If there is a cabin filter, replace 5 µm filter every 1 year If there is no cabin filter, replace 5 µm filter every 3 months 	The frequency of replacing the 5 µm filter depends on whether the filter is present or not in the cabin.
Analysis module	1	Yes	In case of breakage	
Pressure regulator with range 0-16 barg in SS316	1	No	The recommended frequency for replacing the regulator is every 5 years	
Pressure regulator with range 0-10 barg in SS316	1	No	The recommended frequency for replacing the regulator is every 5 years	
Asameter	1	No	In case of breakage	
AISI 316 ball valves of the pneumatic panel	8	No	In case of breakage	
Safety Valve SS316 SET: 15.5 bar	1	No	In case of breakage	
Safety Valve SS316 SET: 0.7 ÷ 16 bar	1	No	In case of breakage	
Non-return valve	1	No	In case of breakage	

Tab. 12.42.

PAGE INTENTIONALLY LEFT BLANK

TM0057ENG

