

Reval 182

Medium-low pressure gas regulator



Revision F - Edition 02/2026

**USER, MAINTENANCE
AND WARNING MANUAL**

PAGE INTENTIONALLY LEFT BLANK

1 - INTRODUCTION

FOREWORD

All rights reserved. No part of this publication may be reproduced, distributed, translated into other languages or transmitted by any electronic or mechanical media, including photocopies, recording or any other storage and retrieval system, for any other purposes that are not exclusively the personal use of the buyer, without the express written permission of the Manufacturer.

The manufacturer is in no way responsible for the consequences of operations carried out in a manner not in accordance with the manual.

GENERAL REMARKS

All operating, maintenance instructions and recommendations described in this manual must be observed. In order to obtain the best performance and to keep the equipment in efficient condition, the manufacturer recommends that maintenance operations be carried out regularly.

It is of particular importance that the personnel responsible for the equipment be trained in its use, maintenance and application of the safety instructions and procedures indicated in this manual.

COPYRIGHT 2026

© PIETRO FIORENTINI S.P.A.

PAGE INTENTIONALLY LEFT BLANK

1.1 - REVISION HISTORY

Revision index	Date
A	01/2022
B	10/2022
C	12/2022
D	11/2024
E	12/2024
F	02/2026

Tab. 1.1.

INDEX

1 - INTRODUCTION	3
1.1 - REVISION HISTORY.....	5
2 - GENERAL INFORMATION	13
2.1 - MANUFACTURER IDENTIFICATION	13
2.2 - IDENTIFICATION OF THE PRODUCT	13
2.3 - REGULATORY FRAMEWORK.....	13
2.4 - WARRANTY	13
2.5 - SYMBOLS USED IN THE MANUAL.....	14
2.6 - ADDRESSEES, SUPPLY AND STORAGE OF THE MANUAL	15
2.7 - LANGUAGE	15
2.8 - APPLIED RATING PLATES	16
2.8.1 - GLOSSARY FOR RATING PLATES.....	18
2.9 - GLOSSARY OF UNITS OF MEASUREMENT	20
2.10 - QUALIFIED PROFESSIONAL FIGURES	21
3 - SAFETY	23
3.1 - GENERAL SAFETY WARNINGS.....	23
3.2 - PERSONAL PROTECTIVE EQUIPMENT.....	24
3.3 - RESIDUAL RISKS	25
3.3.1 - TABLE SHOWING RESIDUAL RISKS DUE TO PRESSURE	26
3.3.2 - TABLE OF RESIDUAL RISKS FOR POTENTIALLY EXPLOSIVE ATMOSPHERES	28
3.4 - OBLIGATIONS AND PROHIBITIONS	30
3.5 - SAFETY PICTOGRAMS	31
3.6 - NOISE LEVEL	31

4 - DESCRIPTION AND OPERATION 33

4.1 - GENERAL DESCRIPTION	33
4.1.1 - REGULATOR REACTION MODES.....	34
4.2 - OPERATION.....	34
4.3 - DESIGNED USE.....	36
4.3.1 - INTENDED USE	36
4.3.2 - REASONABLY FORESEEABLE MISUSE	36
4.3.3 - TYPES OF FLUIDS	36
4.4 - TECHNICAL FEATURES/PERFORMANCE	37
4.5 - POSSIBLE CONFIGURATIONS	38
4.5.1 - BUILT-IN SILENCER	39
4.5.1.1 - BUILT-IN SILENCER DB/182.....	39
4.5.1.2 - SILENCER LDB 171	40
4.5.2 - MONITOR	41
4.5.2.1 - BUILT-IN MONITOR	42
4.5.2.2 - V/25 AND M/A ACCELERATOR VALVES	45
4.5.3 - SLAM-SHUT VALVE	47
4.5.3.1 - BUILT-IN SLAM-SHUT VALVE SA.....	48
4.5.3.2 - SB/82 BUILT-IN SLAM-SHUT VALVE	50
4.5.3.3 - HB/97 BUILT-IN SLAM-SHUT VALVE	52
4.5.4 - SLAM-SHUT VALVE PRESSURE SWITCHES	54

5 - TRANSPORT AND HANDLING 57

5.1 - SPECIFIC WARNINGS FOR TRANSPORT AND HANDLING	57
5.1.1 - PACKAGING AND FASTENERS USED FOR TRANSPORT	58
5.2 - PHYSICAL CHARACTERISTICS OF THE EQUIPMENT	60
5.2.1 - REVAL 182 (+LDB/171).....	60
5.2.2 - REVAL 182 + DB/182	61
5.2.3 - REVAL 182 + PM/182	62
5.2.4 - REVAL 182 + SA	63
5.2.5 - REVAL 182 + SB/82.....	64
5.2.6 - REVAL 182 + HB/97	65
5.2.7 - REVAL 182 + DB/182 + PM/182.....	66
5.2.8 - REVAL 182 + DB/182 + SA.....	68
5.2.9 - REVAL 182 + DB/182 + SB/82	70
5.2.10 - REVAL 182 + DB/182 + HB/97	72
5.3 - EQUIPMENT ANCHORING AND LIFTING METHOD.....	74
5.3.1 - FORKLIFT HANDLING METHOD.....	75
5.3.2 - CRANE HANDLING METHOD.....	77
5.4 - PACKAGING REMOVAL.....	78
5.4.1 - PACKAGING DISPOSAL	78
5.5 - STORAGE AND ENVIRONMENTAL CONDITIONS	79
5.5.1 - PRE-INSTALLATION WARNINGS AFTER PROLONGED STORAGE	79

6 - INSTALLATION 81

6.1 - INSTALLATION PRE-REQUISITES.....	81
6.1.1 - ENVIRONMENTAL CONDITIONS ALLOWED.....	81
6.1.2 - CHECKS BEFORE INSTALLATION.....	82
6.2 - SPECIFIC SAFETY INSTRUCTIONS FOR THE INSTALLATION PHASE	83
6.3 - GENERAL INFORMATION ON CONNECTIONS	84
6.4 - REGULATOR INSTALLATION POSITIONS.....	85
6.5 - INSTALLATION PROCEDURE	86
6.5.1 - EQUIPMENT INSTALLATION PROCEDURES	86
6.5.2 - CONNECTION OF THE SENSING LINES TO THE DOWNSTREAM PIPING.....	86
6.6 - POST-INSTALLATION AND PRE-COMMISSIONING CHECKS	88

7 - COMMISSIONING/MAINTENANCE EQUIPMENT..... 89

- 7.1 - LIST OF EQUIPMENT..... 89
- 7.2 - EQUIPMENT NEEDED FOR THE DIFFERENT CONFIGURATIONS 91

8 - COMMISSIONING 95

- 8.1 - GENERAL WARNINGS 95
 - 8.1.1 - SAFETY REQUIREMENTS FOR COMMISSIONING95
- 8.2 - PRELIMINARY PROCEDURES FOR COMMISSIONING 96
- 8.3 - PROPER COMMISSIONING CHECK 97
- 8.4 - CALIBRATION OF EQUIPMENT AND ACCESSORIES INSTALLED..... 97
- 8.5 - REGULATOR COMMISSIONING PROCEDURE 98
- 8.6 - COMMISSIONING PROCEDURE FOR THE REVAL 182 REGULATOR WITH BUILT-IN MONITOR PM/182.. 100
- 8.7 - COMMISSIONING PROCEDURE FOR THE REVAL 182 REGULATOR WITH BUILT-IN PM/182 MONITOR AND V/25 ACCELERATING VALVE..... 102
- 8.8 - COMMISSIONING PROCEDURE FOR THE REVAL 182 REGULATOR WITH BUILT-IN PM/182 MONITOR AND M/A ACCELERATING VALVE 104
- 8.9 - CHECKING THE SA SLAM-SHUT VALVE FOR SEALING DURING SHUT-OFF 106
 - 8.9.1 - CALIBRATION PROCEDURE FOR PRESSURE SWITCHES MOD. SA..... 108
- 8.10 -COMMISSIONING PROCEDURE FOR THE REVAL 182 REGULATOR WITH BUILT-IN SLAM-SHUT VALVE SB/82 110
 - 8.10.1 - CHECKING THE SB/82 SLAM-SHUT VALVE TIGHTNESS DURING SHUT-OFF 110
 - 8.10.2 -CALIBRATION PROCEDURE FOR PRESSURE SWITCHES MOD. 100 112
- 8.11 -REGULATOR COMMISSIONING PROCEDURE REVAL 182 WITH HB/97 SLAM SHUT VALVE 114
 - 8.11.1 - CHECKING THE SB/97 SLAM-SHUT VALVE FOR SEALING DURING SHUT-OFF114
 - 8.11.2 -COMMISSIONING PROCEDURE AND CALIBRATION OF THE LINE OFF 2.0 DEVICE FOR SLAM-SHUT VALVE HB/97 116
- 8.12 -CALIBRATION OF THE PRESSURE SWITCH FOR LINE OFF 2.0..... 117
- 8.13 -DEVICE CALIBRATION..... 118
 - 8.13.1 -V/25 ACCELERATOR VALVE CALIBRATION..... 118
 - 8.13.2 -CALIBRATION 200/A SERIES PILOTS AND M/A ACCELERATING VALVE..... 118
 - 8.13.3 - CALIBRATION OF PRESSURE SWITCHES MOD. 100 119
 - 8.13.4 - CALIBRATION OF PRESSURE SWITCHES MOD. SA.....120

9 - MAINTENANCE AND FUNCTIONAL CHECKS..... 121

9.1 - GENERAL WARNINGS	121
9.2 - PERIODICALLY CHECKING AND INSPECTING THE EQUIPMENT FOR PROPER OPERATION.....	123
9.3 - ROUTINE MAINTENANCE	124
9.3.1 - GENERAL SAFETY WARNINGS.....	124
9.3.2 - REPLACEMENT FREQUENCY FOR COMPONENTS SUBJECT TO WEAR	125
9.4 - ROUTINE MAINTENANCE PROCEDURES.....	127
9.4.1 - TIGHTENING TORQUES REVAL 182	128
9.4.2 - REPLACING ELEMENTS SUBJECT TO WEAR AND ABRASION.....	165
9.4.3 - REGULATOR MAINTENANCE PROCEDURE REVAL 182.....	166
9.4.4 - SILENCER MAINTENANCE DB/182	216
9.4.5 - PM 182 INCORPORATED MONITOR	224
9.4.6 - 200/A SERIES PILOT MAINTENANCE + PRE-REGULATORS R31/A AND R14/A	254
9.4.7 - V/25 THROTTLE VALVE MAINTENANCE.....	276
9.4.8 - M/A ACCELERATING VALVE MAINTENANCE	280
9.4.9 - SA SLAM-SHUT VALVE MAINTENANCE	284
9.4.10 - MAINTENANCE OF PRESSURE SWITCH MOD. SA	288
9.4.11 - MAINTENANCE BUILT-IN SLAM-SHUT VALVE SB/82	300
9.4.12 - HP2/2 BYPASS DEVICE MAINTENANCE PROCEDURE.....	325
9.4.13 - MAINTENANCE PROCEDURE FOR PRESSURE SWITCHES MOD. 100.....	326
9.4.14 - LINE OFF 2.0 DISCONNECTION.....	338
9.4.15 - MAINTENANCE SLAM-SHUT VALVE INCORPORATED HB/97	340
9.4.16 - LINE OFF 2.0 MAINTENANCE PROCEDURE	352
9.5 - LINE OFF 2.0 RECONNECTION	374
9.5.1 - PROCEDURE FOR RECOMMISSIONING AFTER MAINTENANCE	375

10 - TROUBLESHOOTING..... 377

10.1 -GENERAL WARNINGS	377
10.2 -OPERATOR QUALIFICATION SPECIFICATION.....	378
10.3 -TROUBLESHOOTING PROCEDURES	378
10.4 -TROUBLESHOOTING TABLES	379
10.4.1 - TROUBLESHOOTING REVAL 182 REGULATOR.....	379
10.4.2 - TROUBLESHOOTING OF THE DB/182 SILENCER.....	383
10.4.3 - TROUBLESHOOTING OF MONITOR PM/182	384
10.4.4 - TROUBLESHOOTING OF THE SA SLAM-SHUT VALVE	388
10.4.5 - SB/82 SLAM-SHUT VALVE TROUBLESHOOTING	389
10.4.6 - HB/97 SLAM-SHUT VALVE TROUBLESHOOTING	391

11 - UNINSTALLATION AND DISPOSAL 395

11.1 -GENERAL SAFETY WARNINGS.....	395
11.2 -QUALIFICATION OF THE OPERATORS IN CHARGE.....	395
11.3 -UNINSTALLATION.....	395
11.4 -INFORMATION REQUIRED IN CASE OF RE-INSTALLATION.....	396
11.5 -DISPOSAL INFORMATION.....	396

12 - RECOMMENDED SPARE PARTS 397

12.1 -GENERAL WARNINGS	397
12.2 -HOW TO REQUEST SPARE PARTS.....	397

13 - CALIBRATION TABLES 399

13.1 -CALIBRATION TABLES FOR 200/A SERIES PILOTS AND PRE-REGULATORS	399
13.2 -CALIBRATION TABLES FOR PRESSURE SWITCHES MOD. SA	400
13.3 -CALIBRATION TABLES FOR PRESSURE SWITCHES MOD. 100	402
13.4 -M/A ACCELERATOR VALVE CALIBRATION TABLES.....	404
13.5 -V/25 ACCELERATOR VALVE CALIBRATION TABLES.....	404

PAGE INTENTIONALLY LEFT BLANK

2 - GENERAL INFORMATION

2.1 - MANUFACTURER IDENTIFICATION

Manufacturer	PIETRO FIORENTINI S.P.A.
Address	Via Enrico Fermi, 8/10 36057 Arcugnano (VI) - ITALY Tel. +39 0444 968511 Fax +39 0444 960468 www.fiorentini.com sales@fiorentini.com

Tab. 2.2.

2.2 - IDENTIFICATION OF THE PRODUCT

Equipment	MEDIUM PRESSURE REGULATOR
Model	REVAL 182

Tab. 2.3.

2.3 - REGULATORY FRAMEWORK

PIETRO FIORENTINI S.P.A., with registered offices in Arcugnano (Italy) - Via E. Fermi, 8/10, declares under its sole responsibility that the equipment of the REVAL 182 series described in this manual is designed, manufactured, tested and checked in compliance with the requirements of EN 334 standard on gas pressure regulators.

The equipment meets the requirements of Directive 2014/68/EU (Pressure Equipment Directive PED). The assessment procedure adopted is in accordance with module H1 as per Annex III of the Directive.

NOTICE!

The declaration of conformity in its original version is delivered together with the equipment and this operating and warning manual.

2.4 - WARRANTY

PIETRO FIORENTINI S.P.A. guarantees that the equipment was manufactured using the best materials, with high quality workmanship, and complies with the quality requirements, specifications and performance set out in the order.



The warranty shall be considered null and void and PIETRO FIORENTINI S.P.A. shall not be liable for any damage and/or malfunctions:

- due to any acts or omissions of the purchaser or end-user, or any of their carriers, employees, agents, or any third party or entity;
- in the event that the purchaser, or a third party, makes changes to the equipment supplied by PIETRO FIORENTINI S.P.A. without the prior written approval of the latter;
- in the event of failure by the purchaser to comply with the instructions contained in these instructions, as provided by PIETRO FIORENTINI S.P.A.

NOTICE!

The warranty conditions are specified in the commercial contract.

2.5 - SYMBOLS USED IN THE MANUAL

Symbol	Definition
	Symbol used to identify important warnings for the safety of the operator and/or equipment.
	Symbol used to identify information of particular importance in the manual. The information may also concern the safety of the personnel involved in using the equipment.
	Obligation to consult the instruction manual/booklet. Indicates a requirement for the personnel to refer to (and understand) the operating and warning instructions of the machine before working with or on it.

Tab. 2.4.

HAZARD!

Alerts to a hazard with a high level of risk, an imminent hazardous situation which, if not prevented, will result in death or severe damage.

WARNING!

Alerts to a hazard with a medium level of risk, a potentially hazardous situation which, if not prevented, may result in death or severe damage.

ATTENTION!

Alerts to a hazard with a low level of risk, a potentially hazardous situation which, if not prevented, could result in minor or moderate damage.

NOTICE!

Alerts to specific warnings, directions or notes of particular concern, that are not related to physical injury, as well as practices for which physical injury is not likely to occur.

2.6 - ADDRESSEES, SUPPLY AND STORAGE OF THE MANUAL

The instruction manual is intended for qualified operator responsible for using and managing the equipment throughout its service life.

It contains the necessary information to properly use the equipment and keep its functional and qualitative characteristics unchanged over time. All information and warnings for safe, correct use are also provided.

The manual, as well as the declaration of conformity and/or test certificate, is an integral part of the equipment and must always accompany it whenever it is moved or resold. It is up to the user to keep this documentation intact for reference throughout the lifespan of the equipment.

WARNING!

Removing, rewriting or editing the pages of the manual and their contents is not allowed.

Keep the instruction manual near the equipment, in an accessible place known by all qualified technicians involved in using and running it.

PIETRO FIORENTINI S.p.A. shall not be held liable for any damage to people, animals and property caused by failure to adhere to the warnings and operating procedures described in this manual.

The original manual has been drawn up in Italian.

Any translations into additional languages are to be made from the original instructions.

2.7 - LANGUAGE

The original manual has been drawn up in Italian.

Any translations into additional languages are to be made from the original instruction manual.

HAZARD!

The translations into other languages cannot be fully verified. If any inconsistency is found, please refer to the text of the original manual.

If inconsistencies are found or the text does not make sense:

- stop any actions;
- immediately contact the relevant offices of **PIETRO FIORENTINI S.p.A.**

WARNING!

PIETRO FIORENTINI S.p.A. shall be held liable for the information provided in the original manual only.

2.8 - APPLIED RATING PLATES



WARNING!

**Removing rating plates and/or replacing them with other plates is strictly not allowed.
Should the plates be unintentionally damaged or removed, the customer must notify
PIETRO FIORENTINI S.p.A.**

The equipment and its accessories are provided with nameplates (from Id.1 to Id.8).

The plates specify identification details of the equipment and its accessories to be provided, if necessary, to PIETRO FIORENTINI S.p.A.

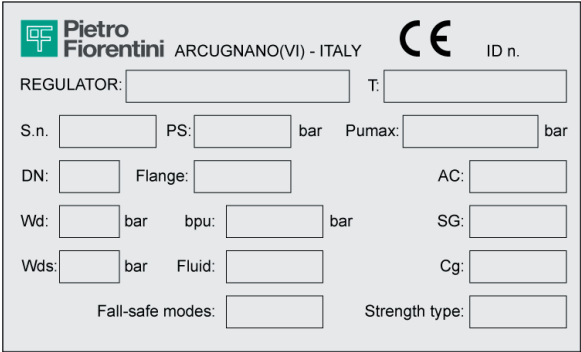
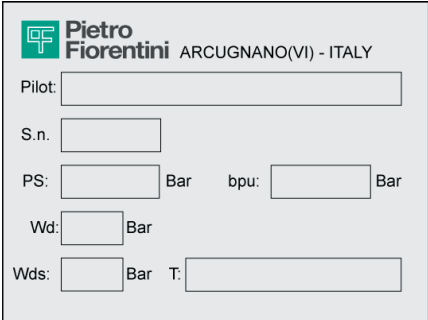
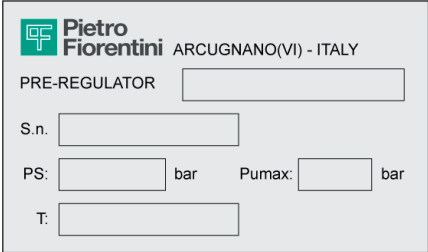
Tab. 2.5 shows the rating plates applied:

Id.	Type	Image
1	RATING PLATE REGULATOR (EC version)	
2	RATING PLATE PILOT	
3	RATING PLATE PRE-REGULATOR	
4	RATING PLATE SILENCER	

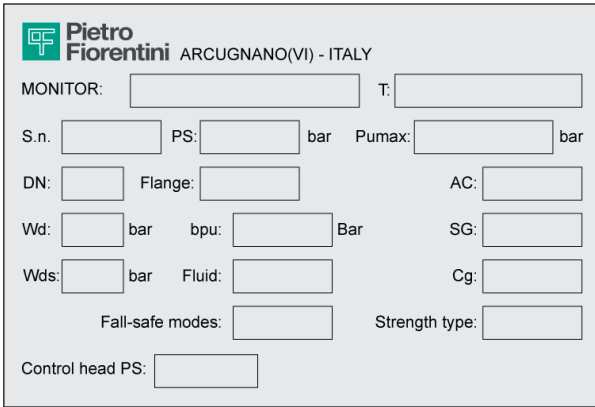
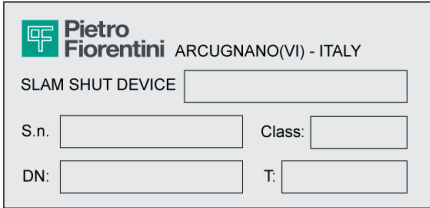
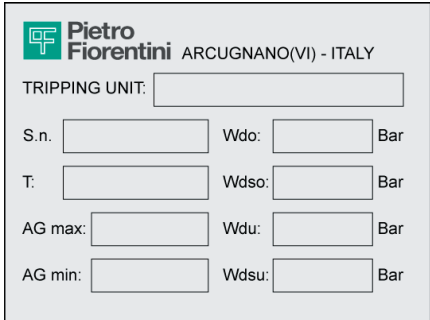
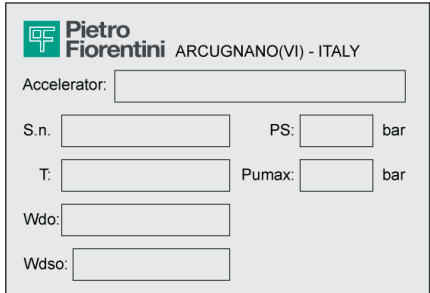
Id.	Type	Image
5	RATING PLATE MONITOR	 <p>Pietro Fiorentini ARCUGNANO(VI) - ITALY</p> <p>MONITOR: <input type="text"/> T: <input type="text"/></p> <p>S.n. <input type="text"/> PS: <input type="text"/> bar Pumax: <input type="text"/> bar</p> <p>DN: <input type="text"/> Flange: <input type="text"/> AC: <input type="text"/></p> <p>Wd: <input type="text"/> bar bpu: <input type="text"/> Bar SG: <input type="text"/></p> <p>Wds: <input type="text"/> bar Fluid: <input type="text"/> Cg: <input type="text"/></p> <p>Fall-safe modes: <input type="text"/> Strength type: <input type="text"/></p> <p>Control head PS: <input type="text"/></p>
6	RATING PLATE SLAM-SHUT VALVE	 <p>Pietro Fiorentini ARCUGNANO(VI) - ITALY</p> <p>SLAM SHUT DEVICE <input type="text"/></p> <p>S.n. <input type="text"/> Class: <input type="text"/></p> <p>DN: <input type="text"/> T: <input type="text"/></p>
7	RATING PLATE PRESSURE SWITCH	 <p>Pietro Fiorentini ARCUGNANO(VI) - ITALY</p> <p>TRIPPING UNIT: <input type="text"/></p> <p>S.n. <input type="text"/> Wdo: <input type="text"/> Bar</p> <p>T: <input type="text"/> Wdso: <input type="text"/> Bar</p> <p>AG max: <input type="text"/> Wdu: <input type="text"/> Bar</p> <p>AG min: <input type="text"/> Wdsu: <input type="text"/> Bar</p>
8	RATING PLATE ACCELERATOR VALVE	 <p>Pietro Fiorentini ARCUGNANO(VI) - ITALY</p> <p>Accelerator: <input type="text"/></p> <p>S.n. <input type="text"/> PS: <input type="text"/> bar</p> <p>T: <input type="text"/> Pumax: <input type="text"/> bar</p> <p>Wdo: <input type="text"/></p> <p>Wdso: <input type="text"/></p>

Tab. 2.5.

2.8.1 - GLOSSARY FOR RATING PLATES

The terms and abbreviations used on rating plates are described in Tab. 2.6:

Term	Description
AC	Accuracy class.
AG max	Slam-shut valve accuracy class due to pressure increase. "OPSO" (Over pressure shut off).
AG min	Slam-shut valve accuracy class due to pressure decrease. "UPSO" (Under pressure shut off).
bpu	Range of inlet pressure for which the regulator ensures a given accuracy class.
CE	Marking certifying compliance with applicable European directives.
Cg	Flow rate coefficient.
Class	Alphanumeric designation used for reference purposes related to a combination of mechanical and dimensional characteristics for flanges, in accordance with the relevant parts of EN 1759 series, which includes the word Class followed by a dimensionless whole number.
DN	Nominal size of connections.
Fail safe mode	Regulator reaction mode (Fail open or Fail close).
Flange	Type of flanged connections or type of connection thread.
Fluid	Type of fluid compatible with the equipment.
ID n.	Number of the Notified Body participating in the conformity assessment of the equipment.
Pilot	Pilot family.
PS	Maximum permissible pressure for which the equipment was designed.
Pumax	Maximum inlet pressure at which the regulator can operate continuously under specific conditions.
REGULATOR	Equipment family.
SG	Shut-off pressure class.
Slam-shut device	Slam-shut valve family.
S.n.	Equipment serial number.
Strength type	Strength class: Integral strength (IS) or differential strength (DS).
T	Permissible temperature range (min. and max.) that the equipment was designed for.
Tripping unit	Pressure switch family.
Type	Accessory type and family.
Wd	Full setpoint range that can be obtained from the regulator by adjusting and/or replacing certain components (e.g. replacement of valve seat or control element, e.g. spring).
Wdo	Full setpoint range with regard to tripping caused by increased pressure in the pressure switch built into the slam-shut valve. This range can be obtained by adjusting and/or replacing the components (for example, spring or sensitive element).
Wds	Full setpoint range that can be obtained from the regulator by adjusting but not replacing the components.
Wdso	Full setpoint range with regard to tripping caused by increased pressure in the pressure switch built into the slam-shut valve. This range can be obtained by adjusting but not replacing the components.

Term	Description
Wdu	Full setpoint range with regard to tripping caused by decreased pressure in the pressure switch built into the slam-shut valve. This range can be obtained by adjusting and/or replacing the components (for example, spring or sensitive element).
Wdsu	Full setpoint range with regard to tripping caused by decreased pressure in the pressure switch built into the slam-shut valve. This range can be obtained by adjusting but not replacing the components.

Tab. 2.6.

2.9 - GLOSSARY OF UNITS OF MEASUREMENT

Type of measurement	Unit of measurement	Description
Volumetric flow rate	Sm ³ /h	Standard cubic metres per hour
	Scfh	Standard cubic feet per hour
Pressure	bar	Unit of measurement in the CGS system
	psi	Pounds per square inch
	"wc	water column inch
	Pa	Pascal
Temperature	°C	Degree centigrade
	°F	Fahrenheit degree
	K	Kelvin
Tightening torque	Nm	Newton metre
	ft-lbs	Foot per pound
Sound pressure	dB	Decibel
Other measurements	V	Volt
	W	Watt
	Ω	Ohm

Tab. 2.7.

2.10 - QUALIFIED PROFESSIONAL FIGURES

Qualified operators in charge of using and managing the equipment throughout its technical service life:

Professional figure	Definition
Mechanical maintenance technician	<p>Qualified technician able to:</p> <ul style="list-style-type: none"> perform preventive/corrective maintenance operations on all mechanical parts of the equipment subject to maintenance or repair; access all device parts for visual inspection, equipment checks, adjustments and settings. <p>The maintenance mechanical technician is not authorised to operate on live electrical systems (if any).</p>
Mechanical electric	<p>Qualified technician able to:</p> <ul style="list-style-type: none"> perform preventive/corrective maintenance operations on all electrical parts of the device subject to maintenance or repair; read wiring diagrams and check the correct functional cycle; perform adjustments and operate on electrical systems for maintenance, repair and replacement of worn parts. <p>The electrical maintenance technician can operate in the presence of voltage inside electrical panels, junction boxes, control equipment etc. only if he/she is deemed to be suitable (S.P.).</p> <p>For general requirements, refer to the IEC EN 50110-1:2014 standard.</p>
Worker in charge of transport, handling, unloading and placement on site	<p>Operator qualified to:</p> <ul style="list-style-type: none"> the use of lifting equipment handle materials and equipment. <p>The equipment must be lifted and handled strictly in accordance with the instructions provided by the manufacturer as well as the regulations in force at the place where the equipment is installed.</p>
Installer	<p>Qualified operator able to:</p> <ul style="list-style-type: none"> carry out all the operations necessary to properly install the equipment safely; perform all the operations necessary to properly operate the equipment and system safely.
User's technician	<p>Technician trained and authorized to use and manage the equipment for the activities for which it was supplied. They must:</p> <ul style="list-style-type: none"> be able to perform all operations required for the proper functioning of the equipment and the system, and for their safety and that of any personnel present; have proven experience in properly using the equipment similar to that described in this manual, and be trained, informed and instructed in this regard. <p>The technician may carry out maintenance only if authorised/qualified to do so.</p>

Tab. 2.8.

PAGE INTENTIONALLY LEFT BLANK

3 - SAFETY

3.1 - GENERAL SAFETY WARNINGS

WARNING!

The equipment described in this manual is:

- a device subjected to pressure in pressurised systems;
- normally installed in systems carrying flammable gases (for example: natural gas).

WARNING!

If the gas used is a combustible gas, the installation area of the equipment is defined as a 'danger zone' as there are residual risks that potentially explosive atmospheres may be generated.

In "danger zones" and in the immediate vicinity, the following are required:

- there must not be any effective sources of ignition;
- no smoking.

ATTENTION!

Authorised operators must not carry out operations or services on their own initiative that do not fall within their competence.

Never operate the equipment:

- while under the influence of intoxicating substances such as alcohol;
- if you are using drugs that may lengthen reaction times.

NOTICE!

The employer must train and inform operators on how to behave during operations and on the equipment to be used.

Before installation, commissioning or maintenance, operators must:

- take note of the safety regulations applicable to the place of installation they are working in;
- obtain the necessary permits to operate when required;
- wear the personal protective equipment required by the procedures described in this instruction manual;
- ensure that the required collective protective equipment and safety information are available in the area they are operating in;

3.2 - PERSONAL PROTECTIVE EQUIPMENT

Tab. 3.9 shows the personal protective equipment (PPE) and its description. An obligation is associated with each symbol. Personal protective equipment means any equipment intended to be worn by the worker in order to protect them against one or several risks that are likely to threaten their safety or health during work.

For the operators in charge, depending on the type of work requested, the most appropriate PPE of the following will be reported and must be used:

Symbol	Meaning
	Obligation to use safety or insulated gloves. Indicates a requirement for the personnel to use safety or insulated gloves.
	Obligation to use safety goggles. Indicates a requirement for personnel to use protective goggles for eye protection.
	Obligation to use safety shoes. Indicates a requirement for personnel to use accident-prevention safety shoes.
	Obligation to use noise protection equipment. Indicates a requirement for the personnel to use ear muffs or ear plugs to protect their hearing.
	Obligation to wear protective clothing. Indicates a requirement for personnel to wear specific protective clothing.
	Obligation to use a protective mask. Indicates a requirement for the personnel to use respiratory masks in the event of a chemical risk.
	Obligation to use a protective helmet. Indicates a requirement for the personnel to use protective helmets.
	Obligation to wear high visibility vests. Indicates a requirement for the personnel to use high visibility vests.

Tab. 3.9.

WARNING!

Each licensed operator is obliged to:

- **take care of his/her own health and safety and that of other people in the workplace who are affected by his/her actions or omissions, in accordance with the training, instructions and equipment provided by the employer;**
- **appropriately use the PPE made available;**
- **immediately report to the employer, the manager or the person in charge any deficiencies in the equipment and devices, as well as any dangerous conditions they may become aware of.**

3.3 - RESIDUAL RISKS

In accordance with the requirements of directive PED 2014/68/EU, point 1.2 of Annex I, below is an assessment of the risks associated with the equipment and an indication of the principles adopted for their prevention, according to the following classification:

- a) Elimination and/or reduction of the risk.
- b) Application of appropriate protective measures.
- c) Information to users about residual risks.

3.3.1 - TABLE SHOWING RESIDUAL RISKS DUE TO PRESSURE

Risk and hazard	Event and Cause	Effect and consequence	Solution and prevention
Pressurised gas leakage. leakage Projection of metallic and non-metallic pressurised parts.	<ul style="list-style-type: none"> Violent impact; Impact (also due to falling, improper handling, etc.). 	<ul style="list-style-type: none"> Deformation; Broken connections and, if pressurised, even burst. 	a. Handling and installation with appropriate devices to avoid localised stress. b. Installation in suitable places and spaces with appropriate guards and packaging. c. Information in the instructions for use and warning.
Pressurised gas leakage. leakage Projection of metallic and non-metallic pressurised parts. metallic and not in leakage	<ul style="list-style-type: none"> Use of inappropriate fluids. 	<ul style="list-style-type: none"> Corrosion; Embrittlement; Explosion. 	a. The user must check compliance of the used fluid with the specifications on the data plate.
Pressurised gas leakage. leakage Projection of metallic and non-metallic pressurised parts. metallic and not in leakage	<ul style="list-style-type: none"> Operation at temperatures below the minimum permissible temperature. 	<ul style="list-style-type: none"> Embrittlement; Breakage; Explosion. 	a. Install in places where the temperature is not below the minimum permissible temperature and/or insulate the equipment adequately. b. The minimum temperature allowed is indicated on the data plate.
Pressurised gas leakage. leakage Projection of metallic and non-metallic pressurised parts. Explosion.	<ul style="list-style-type: none"> Overpressure or exceedance of the rated limit values (maximum pressure allowed) 	<ul style="list-style-type: none"> Explosion; Breaks; Cracks; Permanent deformations. 	a. The device has appropriate design safety margins. b. The user must check the maximum pressure applicable to the equipment. c. The maximum allowable pressure is highlighted on the appropriate plate on the equipment.
Falling of the equipment.	<ul style="list-style-type: none"> Dangerous handling. 	<ul style="list-style-type: none"> Deformation; Cracking; Breakage. 	b. The user must have suitably sized lifting equipment. c. The above requirements are referred to in the equipment use and warning manual.
Pressurised fluid leakage Projection of metallic and non-metallic pressurised parts. metallic and not in leakage	<ul style="list-style-type: none"> Incorrect fastening of the equipment. 	<ul style="list-style-type: none"> Deformation; Breakage. 	a. The device is equipped with unified type process connections and press fittings. b. The user must ensure correct fixing to the line. c. Directions in the instructions for use and warning.

Risk and hazard	Event and Cause	Effect and consequence	Solution and prevention
Explosion of the device. Pressurised fluid leakage Projection of metallic and non-metallic pressurised parts. metallic.	<ul style="list-style-type: none"> Operation at temperatures above the maximum permissible temperature. 	<ul style="list-style-type: none"> Reduction of mechanical resistance and breakage of the device; Explosion. 	a. The user must equip the system with suitable control and safety devices. b. The maximum temperature allowed is indicated on the data plate.
Pressurised gas leakage	<ul style="list-style-type: none"> Equipment maintenance with the system running. 	<ul style="list-style-type: none"> Inappropriate opening of pressurised chambers. 	a. The user must perform any maintenance with the equipment not running. b. The above requirements are referred to in the use and warning instructions.
Pressurised gas leakage Projection of metallic and non-metallic pressurised parts. metallic and not in leakage	<ul style="list-style-type: none"> External loads bearing on the device. 	<ul style="list-style-type: none"> Deformation; Cracking and fissure formation; If under pressure, also bursting. 	a. With the exclusion of what is set out in the design, the user must verify that no additional concentrated load bears on the device.
Pressurised gas leakage Projection of metallic and non-metallic pressurised parts. metallic and not in leakage	<ul style="list-style-type: none"> Electrostatic potential, differential stray currents. 	<ul style="list-style-type: none"> Localised corrosion in the device. 	b. The user must equip the device with the necessary protection and earthing devices. c. The above requirements are referred to in the use and warning manual.
Pressurised gas leakage Projection of metallic and non-metallic pressurised parts. metallic and not in leakage	<ul style="list-style-type: none"> Humidity; Environments with aggressive atmosphere. 	<ul style="list-style-type: none"> Deterioration of external surfaces; Corrosion. 	a. The user must periodically check the state of conservation of the external surfaces. b. The above requirements are referred to in the use and warning instructions.

Tab. 3.10.

3.3.2 - TABLE OF RESIDUAL RISKS FOR POTENTIALLY EXPLOSIVE ATMOSPHERES

Tab. 3.11 shows the conditions that can lead to the generation of a potentially explosive atmosphere respectively for:

- REVAL 182 pressure regulator;
- the PM/182 monitor;
- of slam-shut valves SA, SB/82, HB/97.

Considering that the silencer does not have active functional parts, in this analysis it is considered an integral part of the REVAL 182 regulator.

The table is valid for use with natural gas with a density of no more than 0.8; for different densities, the installation and environmental conditions must also be evaluated.

! WARNING!

If the gas used is a combustible gas, the installation area of the equipment is defined as a 'danger zone' as there are residual risks that potentially explosive atmospheres may be generated.

There must be no effective sources of ignition in 'danger zones' and in close proximity thereto.

Operational operational	Atmosphere potentially explosive	Normative references	Management measures included in the instructions for use and warning
First start-up	No	<ul style="list-style-type: none"> • During the production cycle and before the CE marking according to Directive 2014/68/EU, the external tightness of the equipment is checked at a value of 1.1 PS (in accordance with Standard EN 334). • Before commissioning, the external sealing of the system portion on which the equipment is installed is checked at a suitable pressure (in accordance with the provisions of standards EN 12186 and EN 12279). 	The instructions for use indicate the need to meet the requirements in Standards EN 12186 and EN 12279.
Operation in normal conditions	No	<p>The indications in the previous point apply, in addition:</p> <ul style="list-style-type: none"> • the equipment is installed outdoors or in an environment with natural ventilation (in accordance with Standards EN 12186 and EN 12279); • the installation is subject to surveillance according to current national rules/good practice/the equipment manufacturer's instructions (in accordance with the provisions of Standard EN 12186 and Standard EN 12279). 	<p>The instructions for use indicate that:</p> <ul style="list-style-type: none"> • any environment in which the equipment is installed must meet the requirement of Standards EN 12186 and EN 12279; • periodic checks and maintenance must be carried out during surveillance in accordance with the national rules in force (if any), and with the specific manufacturer's recommendations.

Operational operational	Atmosphere potentially explosive	Normative references	Management measures included in the instructions for use and warning
Breakage of the control head diaphragm (malfunction)	No	This event must be considered a rare malfunction. All atmospheric pressure chambers delimited on at least one side by a diaphragm must be channelled to a safe area (in accordance with the provisions of Standard EN 12186 and Standard EN 12279).	The instructions for use indicate the need to meet the requirements of Standards EN 12186 and EN 12279.
Breakage of other parts non-metallic (malfunction)	No	This type of malfunction is not reasonably expected as it involves static sealing (to the outside).	-
Decommissioning	No	<ul style="list-style-type: none"> The pressure of the system section in which the equipment is installed must be reduced with appropriate vent lines channelled to a safe area (in accordance with the provisions of Standard EN 12186 and Standard EN 12279). The residual gas must be discharged as indicated above. 	The instructions for use indicate the need to meet the requirements of Standards EN 12186 and EN 12279
Reboot	No	<ul style="list-style-type: none"> After reassembling the regulator, carry out an external leakage test at a convenient pressure value as specified by the manufacturer. Before commissioning, the external sealing of the system portion on which the equipment is installed is checked at a suitable pressure (in accordance with the provisions of standards EN 12186 and EN 12279). 	The instructions for use indicate: <ul style="list-style-type: none"> the minimum conditions for testing external leakage; the need to meet the requirements of Standards EN 12186 and EN 12279.

Tab. 3.11.

3.4 - OBLIGATIONS AND PROHIBITIONS

The following is a list of obligations and prohibitions to be observed for the safety of the operator.

It is compulsory:



- to carefully read and understand the instructions for use and warning;
- to check whether the downstream equipment is suitably sized according to the performance required of the regulator in the actual operating condition;
- before installing the equipment, to strictly refer to the details specified on the nameplates;
- to avoid violent shocks and impacts that could damage the equipment and, as a result, cause the pressurised fluid to leak.

It is forbidden to:

- operate in various capacities on the equipment without the PPE indicated in the work procedures described in these use and warning instructions;
- operate in the presence of open flames or bring open flames close to the work area;
- smoke near the equipment or while working on it;
- use the equipment with parameters other than those indicated on the name plate;
- use the equipment with fluids other than those indicated on the rating plate and in these use and warning instructions;
- use the equipment outside the operating temperature range specified on the rating plate and in these use and warning instructions;
- service the equipment with the system portion, on which it is installed, in operation;
- install or use the equipment in environments other than those specified in these instructions for use and warning.

3.5 - SAFETY PICTOGRAMS

The following safety pictograms may be shown on the equipment and/or packaging PIETRO FIORENTINI S.p.A.:

Symbol	Definition
	Symbol used to identify an ELECTRICAL HAZARD.
	Symbol used to identify a GENERIC HAZARD.

Tab. 3.12.

 **HAZARD!**

It is absolutely forbidden to remove the safety pictograms on the equipment. The user is required to replace the safety pictograms which, following wear, removal or tampering, are illegible.

3.6 - NOISE LEVEL

Depending on the operating conditions, for the required use and configuration, the equipment may generate noise beyond the limits allowed by current legislation in the country of installation. For the value of the noise generated by the equipment and further information, contact PIETRO FIORENTINI S.p.A.

 **ATTENTION!**

The obligation to use earmuffs or ear plugs to protect the operator's hearing remains in the event that the noise in the installation environment of the equipment (depending on specific operating conditions) exceeds the value of 85 dBA.

PAGE INTENTIONALLY LEFT BLANK

4 - DESCRIPTION AND OPERATION

4.1 - GENERAL DESCRIPTION

The equipment REVAL 182 is a piloted pressure regulator for medium and low pressure which reduces the inlet gas pressure, keeping the downstream value stable even when the following varies:

- inlet pressure value;
- the required flow rate within the operating conditions of the equipment.

The main elements of the equipment are (see Fig. 4.1):

Pos.	Description	Pos.	Description
1	Main regulator	6	Reinforced gasket
2	Piloting unit	7	Main plug
3	Pre-regulator R31/A	8	Main diaphragm
4	Pilot 201/A	9	Pre-regulator R14/A
5	Main regulator body	10	Pilot 204/A

Tab. 4.13.

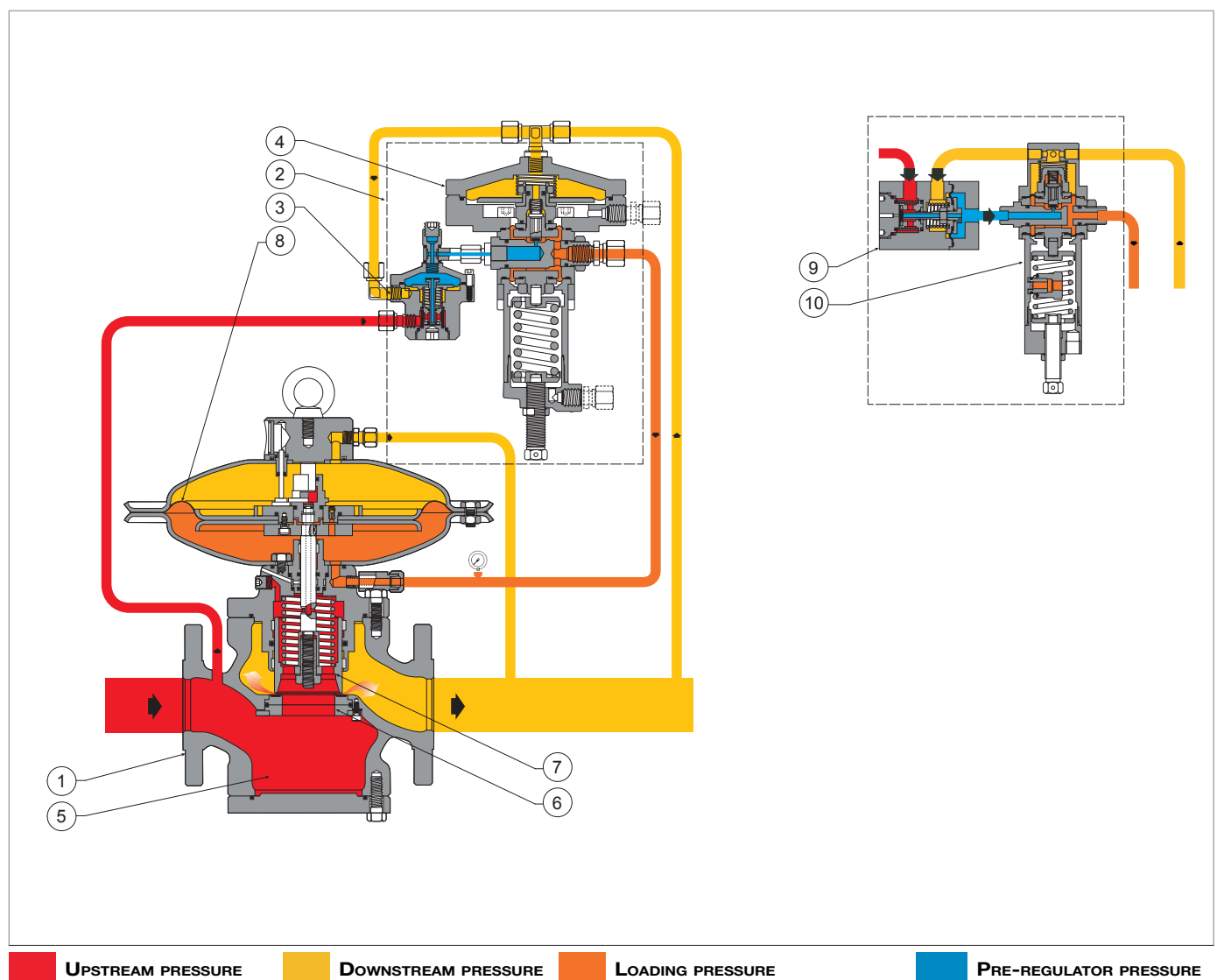

Fig. 4.1. General description REVAL 182

4.1.1 - REGULATOR REACTION MODES

The REVAL 182 equipment is a regulator controlled with a "fail close" reaction (on-closure reaction), that is, it closes in the event of:

- breakage of main diaphragm;
- breakage of pilot 204/A diaphragm;
- no power supply to the pilot.

4.2 - OPERATION

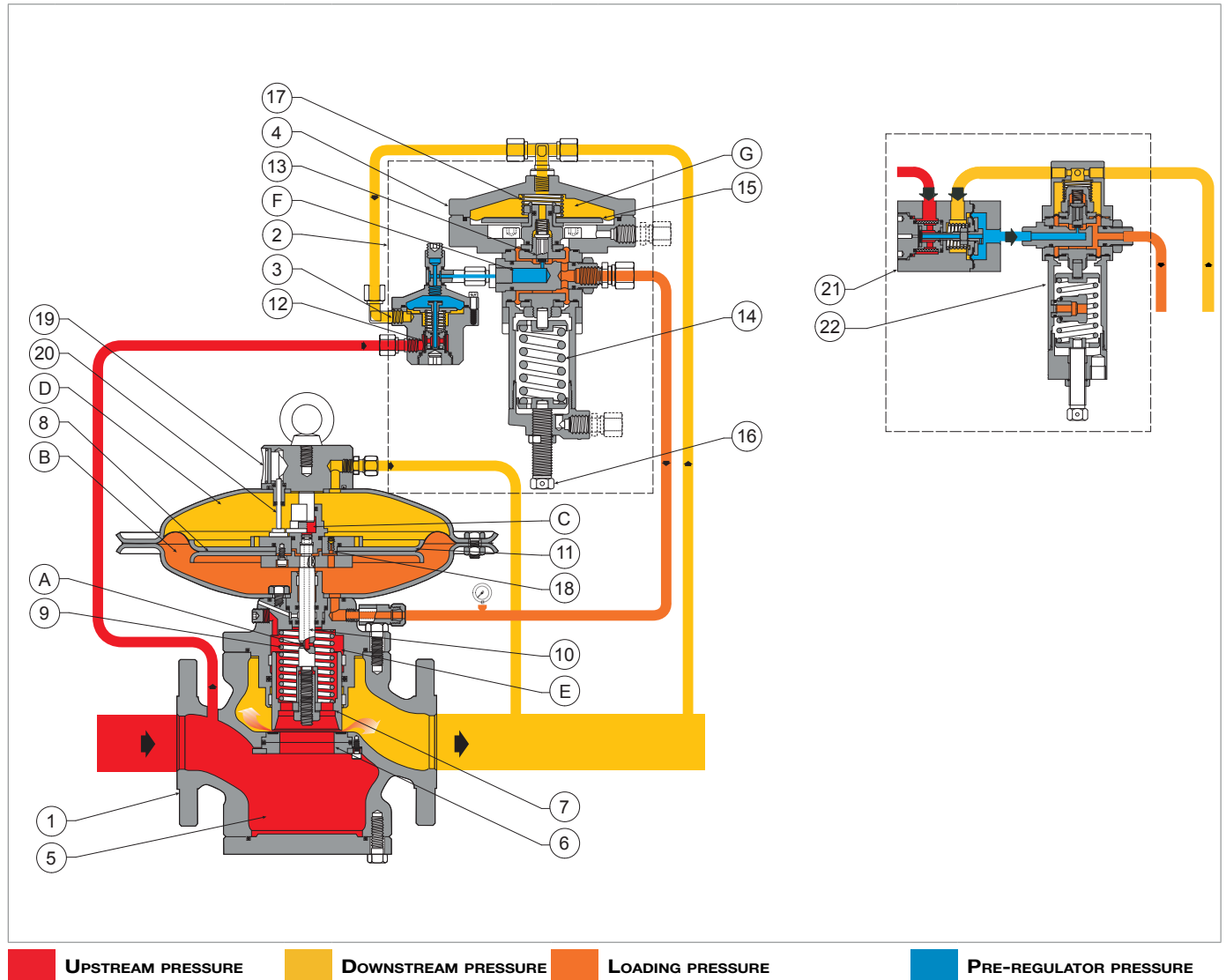

Fig. 4.2. Operation REVAL 182

In depressurised conditions, the plug (7) is kept in a shut-off position by the spring (9) and rests on the reinforced gasket (6). The upstream pressure (P_u), although variable, does not change this position since the plug is fully balanced.

The upstream pressure (P_u) passes through the hole (A) in the stem (10) into the chamber (C). The stem (10) is balanced between two equal pressures.

The position of the regulator plug (7) is controlled by the diaphragm (8) on which the following forces act:

- towards the shut-off position: the load of the spring (9) and the thrust resulting from the downstream pressure (P_d) in the chamber (D);
- towards the open position: thrust derived from the loading pressure (P_m) in the chamber (E), fed by the pilot (4).

The loading pressure (P_m) is obtained by taking gas from the upstream pressure (P_u) of the regulator. The gas passes through the filter (12) and is subjected to an initial decompression in the R31/A pre-regulator (3) up to the pressure value at the pre-regulator (P_{up}).

The pressure at the pre-regulator (P_{up}) passes inside the valve seat (F) of the pilot (4). The plug (13) of the pilot reduces the pressure at the pre-regulator to the value of the loading pressure (P_m) at the regulator head. The loading pressure (P_m) is set by comparing:

- the force exerted by the setting spring (14) on the pilot (4);
- the action of the downstream pressure (P_d), which acts on the diaphragm (15) in the chamber (G).

The drive circuit is an open circuit with continuous discharge, through a transfer hole (18) in the diaphragm protection disc, into the downstream pressure in the chamber (D).

Under normal operating conditions, the plug (13) of the pilot is positioned so that the value of the loading pressure (P_m) is such that the value of the downstream pressure (P_d) remains around the set value.

If, during operation, the following should occur:

Operating conditions	Operating consequences	Outcome
Drop in downstream pressure (P_d) for: <ul style="list-style-type: none"> • rise in the requested flow rate; • drop in upstream pressure (P_u). 	Imbalance between the force of the pressure in the chamber (G) and the setting spring (14) of the pilot (4) causing: <ul style="list-style-type: none"> • increased opening of the pilot (4) plug (13); • increase in the loading pressure value (P_m) 	Opening of the main regulator (1) plug (7) until forces between the downstream pressure (P_d) in the chamber (G) and the pilot (4) calibration spring (14) have been balanced again.
Increased downstream pressure (P_d) due to: <ul style="list-style-type: none"> • drop in the requested flow rate; • increase in upstream pressure (P_u). 	Imbalance between the force of the pressure in the chamber (G) and the setting spring (14) of the pilot (4) causing: <ul style="list-style-type: none"> • the plug (13) of the pilot (4) to shut off; • decrease in the loading pressure (P_m) due to the transfer of this pressure between the chambers (B) and (D) of the regulator (1) through the transfer hole (18) 	Close the plug (7) of the main regulator until the downstream pressure (P_d) has been restored to the pre-set value and the forces between the downstream pressure (P_d) in the chamber (G) and the setting spring (14) of the pilot (4) are balanced.

Tab. 4.14.

 **NOTICE!**

To check the position of the plug (7), look at the position of the stroke indicator rod (20) referring to the slide (19):

- fully open 100%;
- closed 0%.

4.3 - DESIGNED USE

4.3.1 - INTENDED USE

The equipment in question is intended for:

Operation	Permitted	Not permitted	Work environment
Adjustment of the downstream pressure for:	Gaseous, and non-corrosive, fluids that have been filtered beforehand.	<ul style="list-style-type: none"> Liquids. Any product other than those permitted. 	Installations to carry and convey natural gas to networks for: <ul style="list-style-type: none"> civil use; industrial use.

Tab. 4.15.

The equipment in question is used as a main controller and in-line monitor controller.

It was designed to be used exclusively within the limits specified on the rating plate and according to the instructions and limits of use referred to in this manual.

Safe work conditions are as follows:

- use within the limits stated on the rating plate and in this manual;
- compliance with the user manual procedures;
- routine maintenance to be carried out when and how recommended;
- special maintenance to be carried out if required;
- do not tamper with and/or bypass the safety devices.

4.3.2 - REASONABLY FORESEEABLE MISUSE

Incorrect and reasonably foreseeable use means the use of the equipment in a way not foreseen in the phase but which can result from readily foreseeable human behaviour:

- corrosive fluids;
- fluids not properly treated upstream;
- liquids;
- instinctive reaction of an operator in the event of a malfunction, accident or breakdown while using the equipment;
- behaviour resulting from pressure to keep the equipment running under all circumstances;
- behaviour resulting from carelessness;
- behaviour resulting from the use of the equipment by unauthorised and unsuitable people;
- using the equipment in a manner other than that referred to under paragraph "Intended use";

Any use of the equipment other than the intended use must be previously approved in writing by PIETRO FIORENTINI S.p.A. If no written approval is provided, use shall be considered "improper".

In the event of improper use, PIETRO FIORENTINI S.p.A. shall not be held liable for any damage caused to people or property, and any type of warranty on the equipment shall be deemed void.

4.3.3 - TYPES OF FLUIDS

The equipment works with combustible gases used:

- in pressure control stations according to EN 12186 or EN 12279;
- in transmission and distribution networks.
- in commercial and industrial plants (after checking by contacting the Manufacturer).

NOTICE!

The equipment may be also used with inert gases, subject to verification by contacting the manufacturer.

4.4 - TECHNICAL FEATURES/PERFORMANCE

The equipment REVAL 182 is a medium and low pressure regulator. The regulation system is balanced and guarantees a stable outlet pressure even when the inlet pressure varies.

The main specifications for this regulator are:

Technical features	
Maximum allowable pressure	Up to 25 bar
Ambient temperature range	-20 °C ÷ +60 °C
Inlet gas temperature range	-20 °C + 60 °C
Inlet pressure range (bpu)	0.2 - 25 bar
Possible regulation range (Wd)	0.007 ÷ 12 bar (depending on installed pilot)
Minimum differential pressure	0.1 bar
Accuracy class (AC)	up to 2.5 (depending on operating conditions)
Lock up pressure class (SG)	up to 5 (depending on operating conditions)
Connections	Class 150 RF or RTJ according to ASME B16.5 and PN16, 25 and 40 according to ISO 7005

Tab. 4.16.

Cg, Kg and K1 coefficients								
Nominal diameter [mm]	25	50	65	80	100	150	200	250
Size [inches]	1"	2"	2" 1/2	3"	4"	6"	8"	10"
Coefficient Cg	575	2220	3320	4937	8000	16607	25933	36525
Kg coefficient	605	2335	4197	5194	8416	17471	27282	38425
Coefficient K1	106.78	106.78	106.78	106.78	106.78	106.78	106.78	106.78

Tab. 4.17.

The equipment REVAL 182 and the PM/182 monitor are equipped with pilots:

Pilot type	Calibration range (bar)	AG
201/A	0.007 ÷ 0.1	20
	0.1 ÷ 0.58	10
204/A	0.3 ÷ 0.58	20
	0.58 ÷ 12	10

Tab. 4.18.

4.5 - POSSIBLE CONFIGURATIONS

The REVAL 182 equipment can have different configurations through the installation of the following accessories:

- Incorporated silencer DB/182;
- Built-in silencer LDB/171;
- Built-in monitor PM/182 (up to DN 8");
- Built-in slam-shut valve SA (DN 1" to DN 4");
- Built-in slam-shut valve SB/82;
- Built-in slam-shut valve HB/97 (DN 4" to DN 10").

The possible configurations are listed in Tab. 4.19:

REVAL 182	DB/182	LDB/171	PM/182	SA	SB/82	HB/97
DB/182	-	No	Yes	Yes	Yes	Yes
LDB/171	No	-	Yes	Yes	Yes	Yes
PM/182	Yes	Yes	-	No	No	No
SA	Yes	Yes	No	-	No	No
SB/82	Yes	Yes	No	No	-	No
HB/97	Yes	Yes	No	No	No	-

Tab. 4.19.

The accessories can be installed directly at the factory or, at a later time, directly on site.

 **NOTICE!**

The installation of accessories is described in the relevant chapter of this manual.

4.5.1 - BUILT-IN SILENCER

4.5.1.1 - BUILT-IN SILENCER DB/182

The DB/182 silencer (1) is incorporated in the regulator (2).

The DB/182 silencer (1) attenuates the noise generated by the equipment during the rolling process. Noise is absorbed precisely where it is generated, which prevents it from propagating.

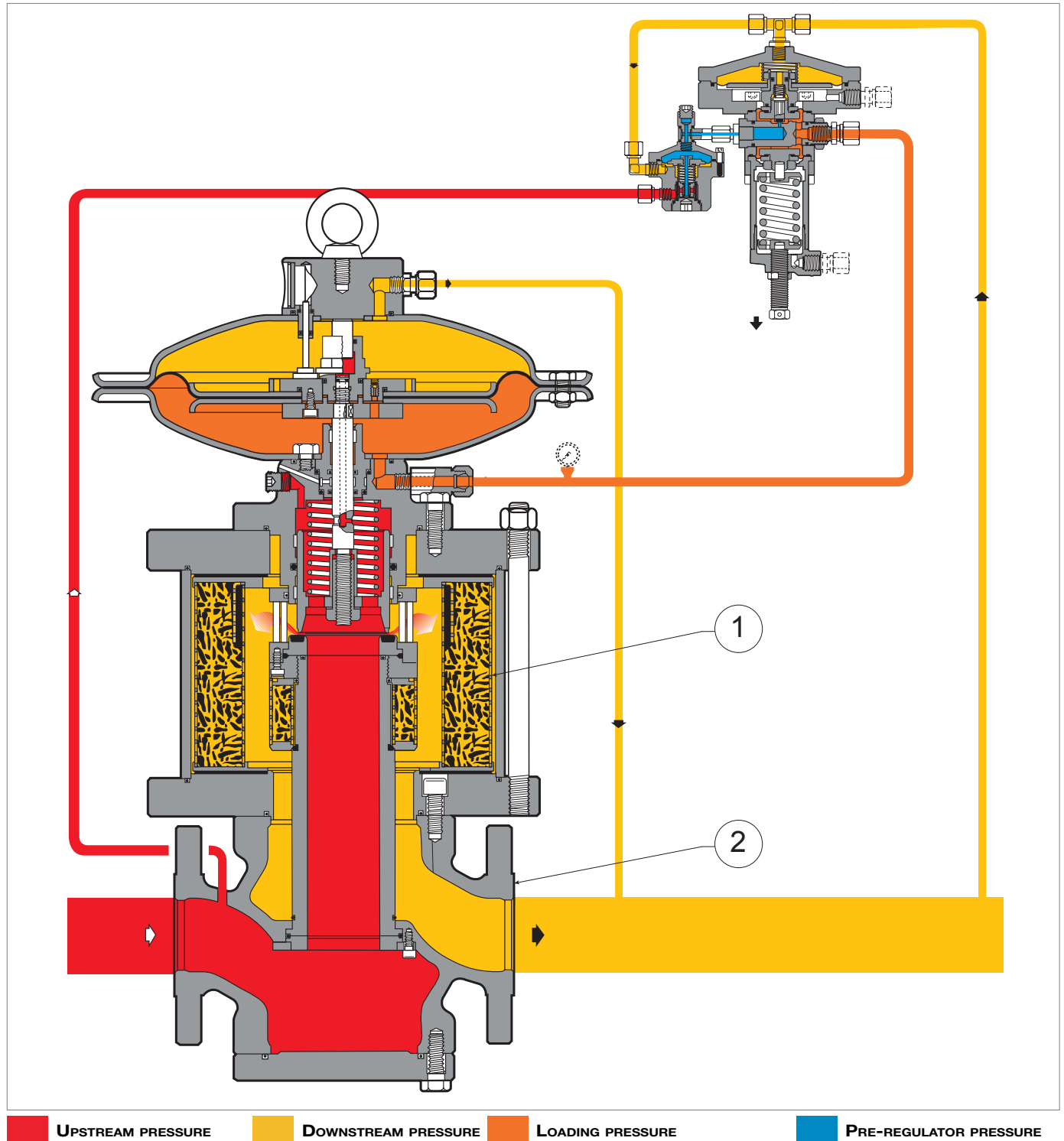

Fig. 4.3. Built-in silencer DB/182

4.5.1.2 - SILENCER LDB 171

The LDB/171 silencer (1) is incorporated in the regulator (2).

The LDB/171 silencer (1) reduces the noise generated by the equipment during the lamination process. Noise is absorbed precisely where it is generated, which prevents it from propagating.

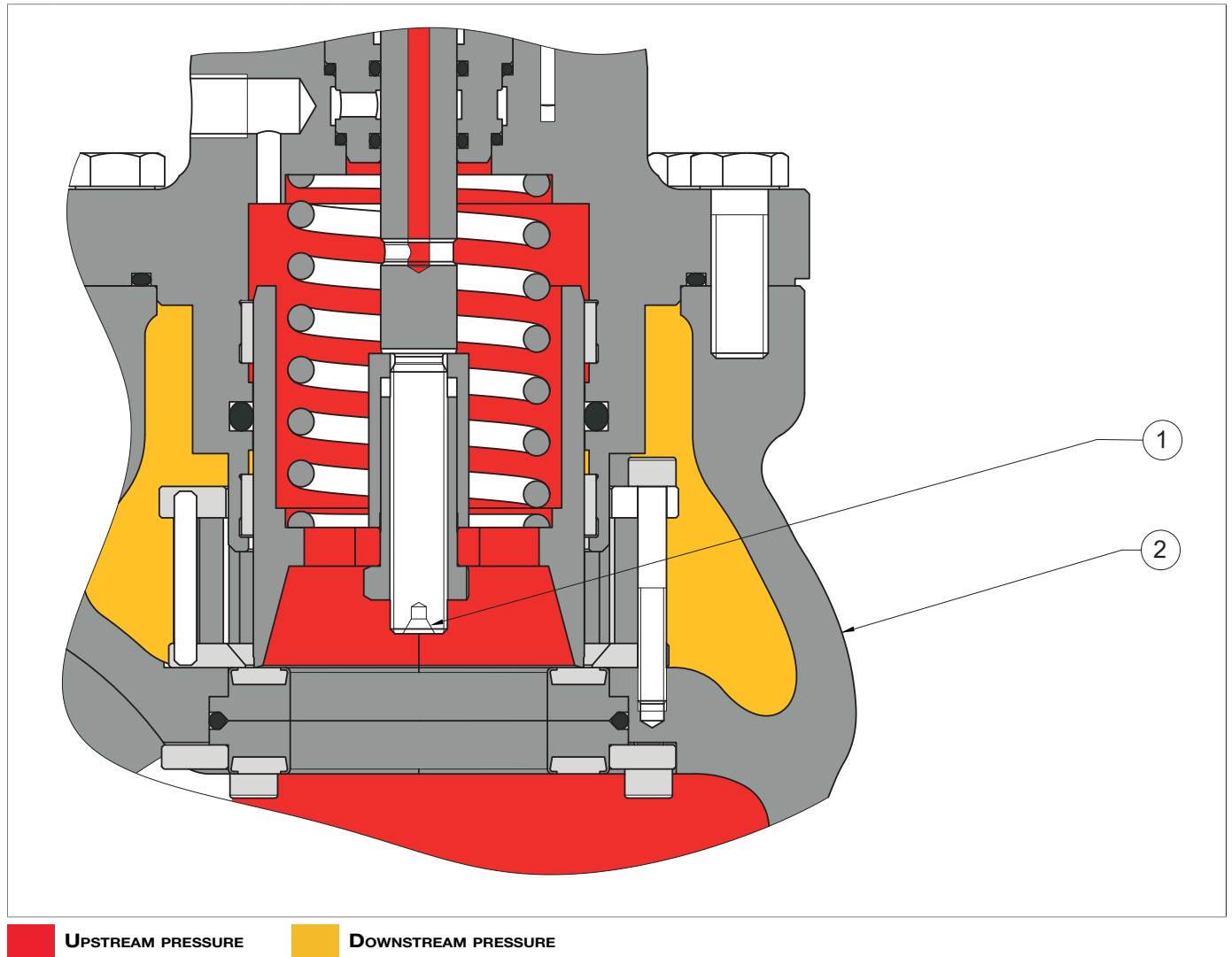

Fig. 4.4. Built-in silencer LDB/171

4.5.2 - MONITOR

The PM/182 monitor (1) is normally installed upstream of the main pressure regulator (2) in a fully open position during normal operation.

The PM/182 (1) monitor is used to keep the pressure value downstream of the main regulator within the pre-set limits in case of failure.

The PM/182 monitor (1) is incorporated in the regulator (2).

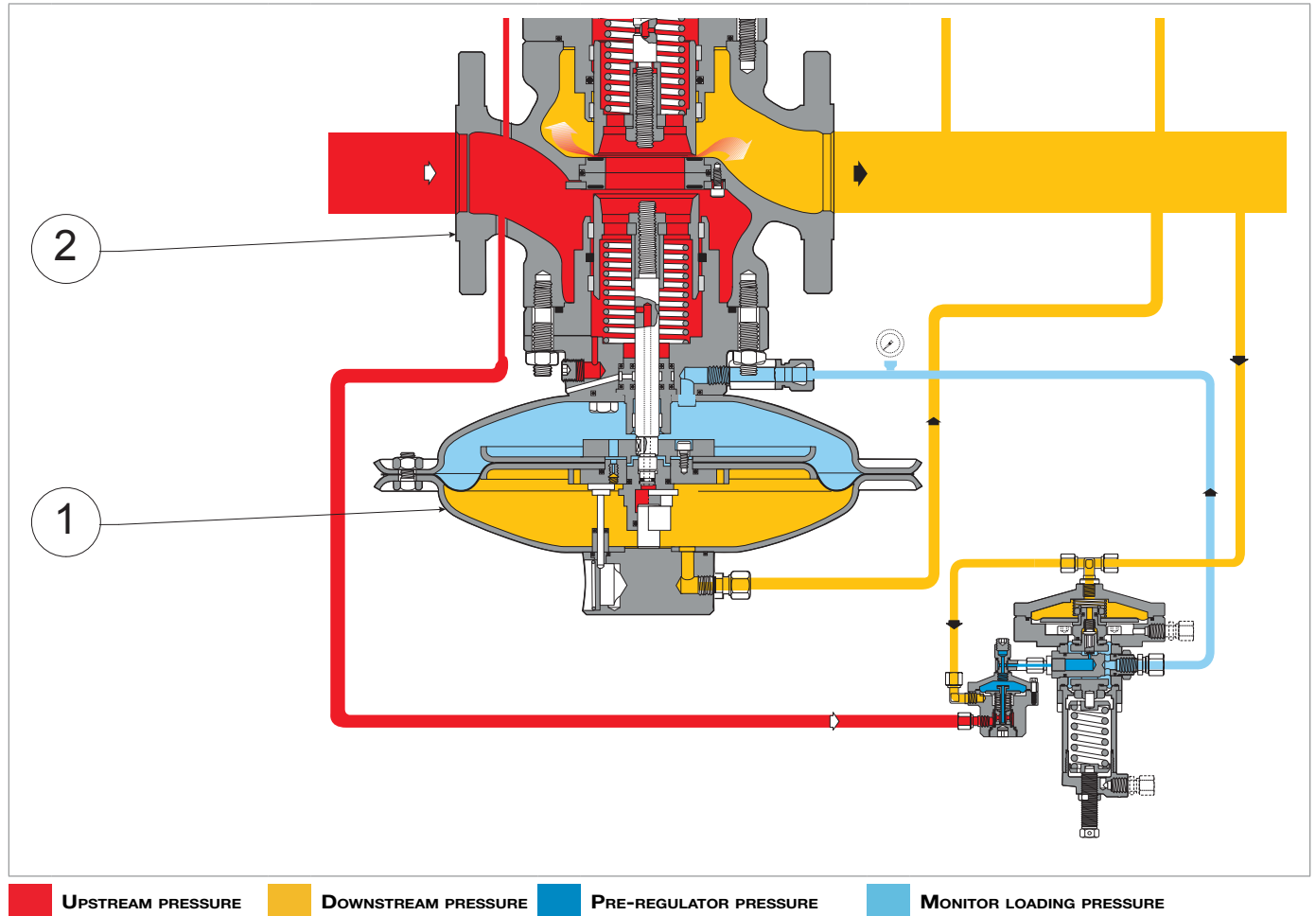

Fig. 4.5. REVAL 182 with built-in monitor PM/182

4.5.2.1 - BUILT-IN MONITOR

The PM/182 monitor (1) is mounted in series directly on the service controller body (2), converting the equipment into two pressure regulators with a common valve body. The two regulators have the following characteristics:

- are governed by two separate pilots;
- they work on independent valve seats.

BUILT-IN MONITOR OPERATION

In the absence of pressure, the plug (3) is held in the closed position by the spring (4) and rests on the reinforced seal (5).

The upstream pressure (P_u), even if variable, does not change this position as the plug (3) is completely balanced, just like the stem (6), as a result of the upstream pressure (U_p), through the hole (A), in the chamber (B).

The position of the plug (3) is controlled by the movements of the diaphragm (7) on which the forces act:

- towards the closed position: the load of the spring (4) and the thrust resulting from the downstream pressure (P_d) in the chamber (C),
- towards the open position: the thrust resulting from the loading pressure (P_m) in the chamber (D), supplied by the pilot (8).

The weight of the mobile unit acts towards the shut-off or open position depending on the installation position of the regulator (2).

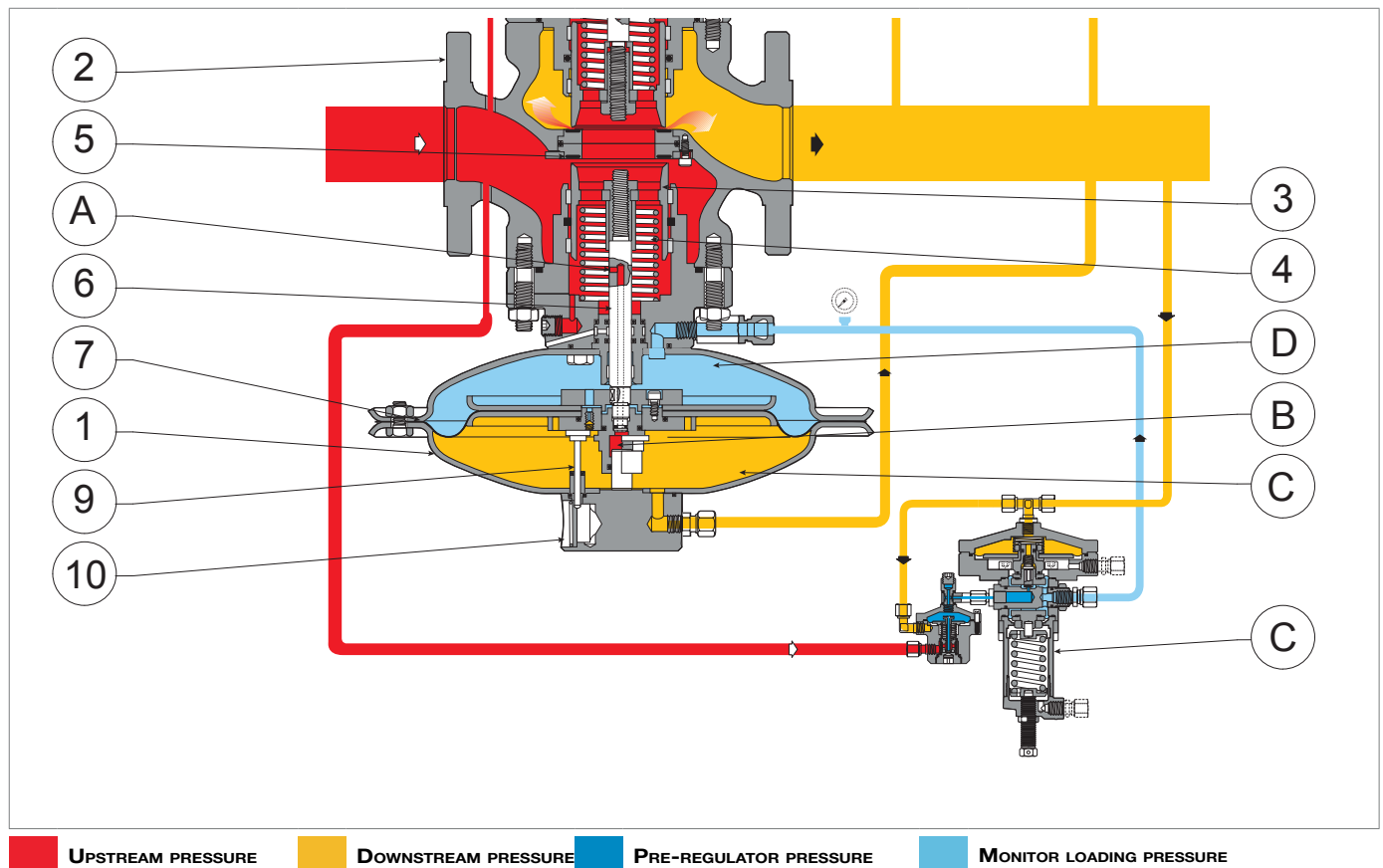

Fig. 4.6. Incorporated monitor operation

NOTICE!

To check the position of the plug (3), look at the position of the stroke indicator rod (9) referring to the glass cover (10):

- fully open 100%;
- closed 0%.

OPERATION OF THE BUILT-IN MONITOR IN STAND-BY CONDITIONS:

The built-in PM/182 monitor (1), during regular operation, is normally open given the pilot calibration (4) which is higher than the main regulator pilot calibration (2).

The passage of the pre-regulator pressure (Pep) generated by the pre-reducer R31/A (5) through the fully open pilot (4) keeps the built-in monitor PM/182 (1) fully open.

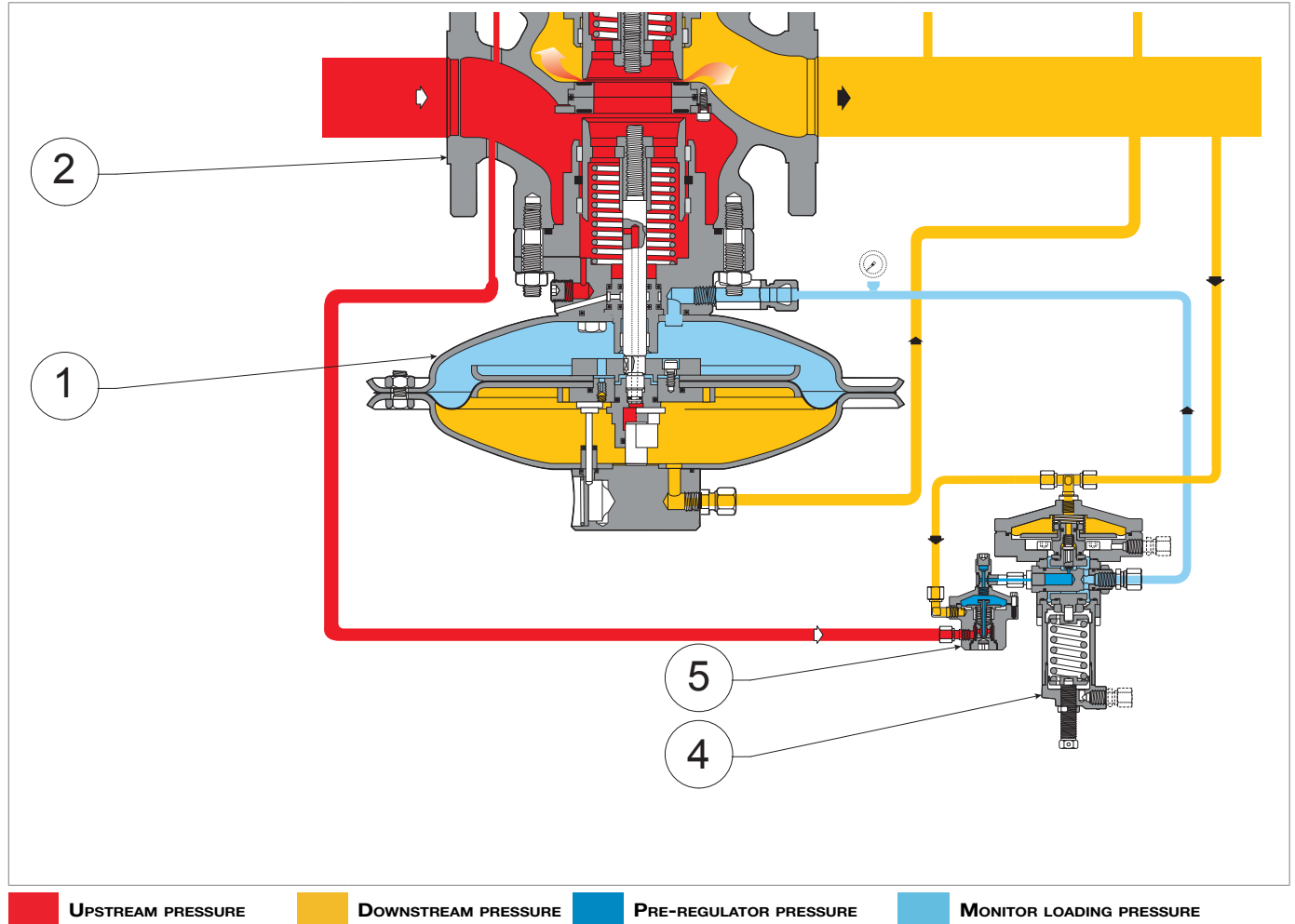

Fig. 4.7. Operation of the built-in monitor in stand-by conditions

BUILT-IN MONITOR OPERATION IN THE EVENT OF FAILURE OF THE MAIN REGULATOR:

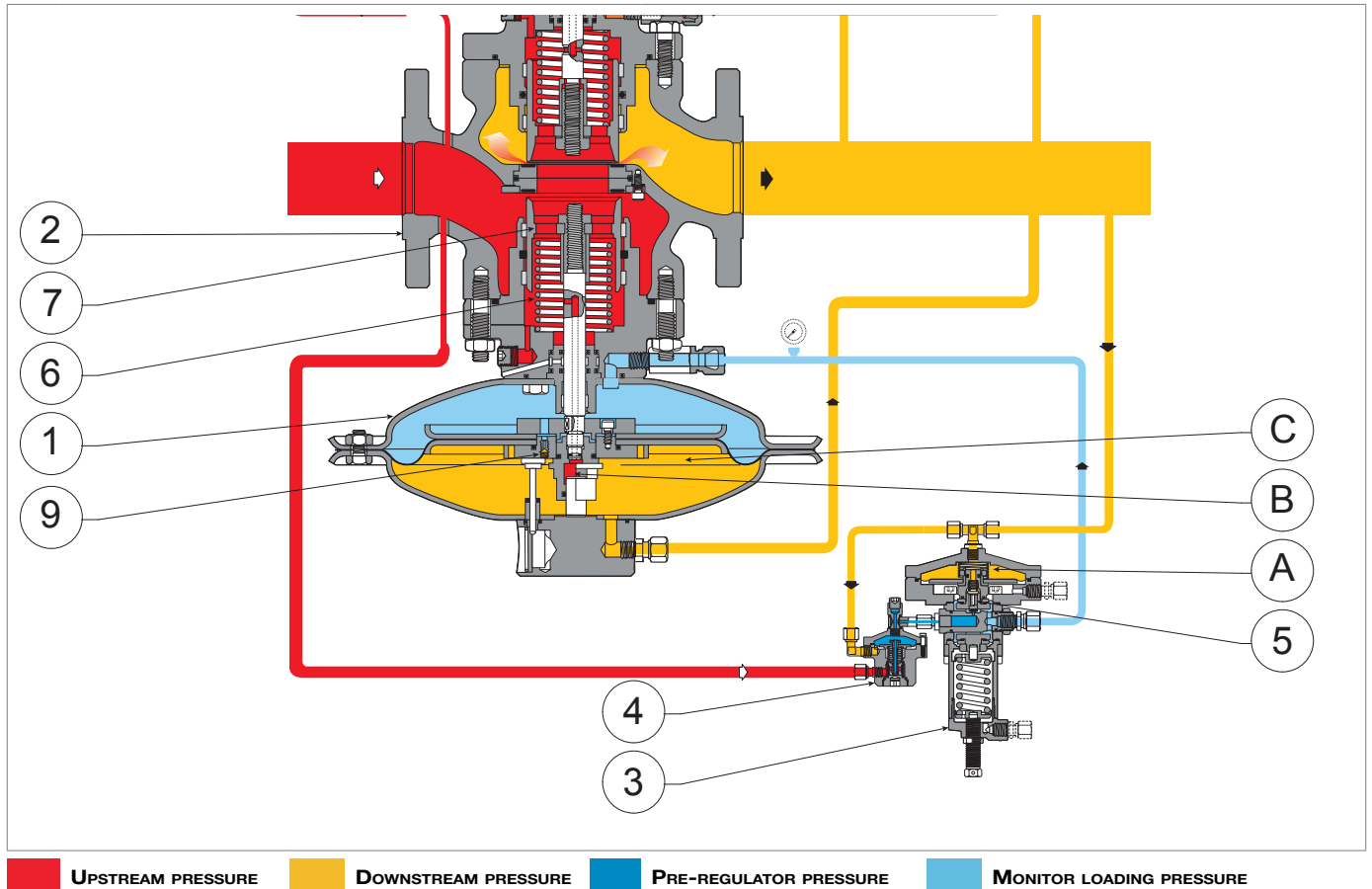

Fig. 4.8. Built-in monitor operation in the event of failure of the main regulator

Should the main regulator (2) fail, the PM/182 monitor (1) will trip until balanced adjustment is achieved. If, during operation, the following should occur:

Operating conditions	Operating consequences	Outcome
<p>Decrease in downstream pressure (Pd) due to:</p> <ul style="list-style-type: none"> • rise in the requested flow rate; • decrease in upstream pressure (Up). 	<p>Imbalance between the pressure force in the chamber (A) and the calibration spring (3) of the pilot (4) which causes:</p> <ul style="list-style-type: none"> • increased opening of the pilot (4) plug (5); • consequent increase in the value of the loading pressure (Pm), inside the chamber (B). 	<p>Opening of the main regulator (2) plug (7) until forces between the downstream pressure (Pd) in the chamber (A) and the pilot (4) calibration spring (3) have been balanced again.</p>
<p>Increase in downstream pressure (Pd) with the pilot (4) plug (5) being moved to the shut-off position.</p>	<p>Moving the main regulator (2) plug (7) to the shut-off position due to:</p> <ul style="list-style-type: none"> • the plug (13) of the pilot (4) to shut off; • decrease in the loading pressure (Pm) due to the transfer of this pressure between the chambers (B) and (D) of the regulator (1) through the transfer hole (18) 	<p>Close the plug (7) of the main regulator until the downstream pressure (Pd) has been restored to the pre-set value and the forces between the downstream pressure (Pd) in the chamber (G) and the setting spring (14) of the pilot (4) are balanced.</p>

Tab. 4.20.

4.5.2.2 - V/25 AND M/A ACCELERATOR VALVES

NOTICE!

For use of the monitor as a safety accessory according to Directive 2014/68/EU 'PED', the installation of V/25 or M/A throttle valves is recommended.

In the event of faults with the main regulator (2), to speed up the intervention of the built-in monitor PM/182 (1), throttle valves will be installed

- V/25 (3, Fig. 4.9), in case of downstream pressure (Pd) up to 0.6 bar
- M/A (3, Fig. 4.10), in the case of downstream pressure (Pd) from 0.55 bar.

The throttle valve, based on a downstream pressure signal (Pd), discharges the gas contained in the loading chamber of the monitor into the atmosphere, thus enabling more rapid tripping.

The setting of the accelerating valves must be higher than the monitor's cut-off pressure (1) with reference to the specific cut-off pressure value (refer to the identification plates in par. 2.8).

Calibration is performed by turning:

- the adjustment ring nut (4, Fig. 4.9) for valve V/25
 - the adjusting screw (4, Fig. 4.10) for the M/A valve
- clockwise or anticlockwise to increase or decrease its value.

Accelerator valve	Set	Operating range (bar)
V/25	max	0.015 ÷ 0.6
M/A	max	> 0.55

Tab. 4.21.

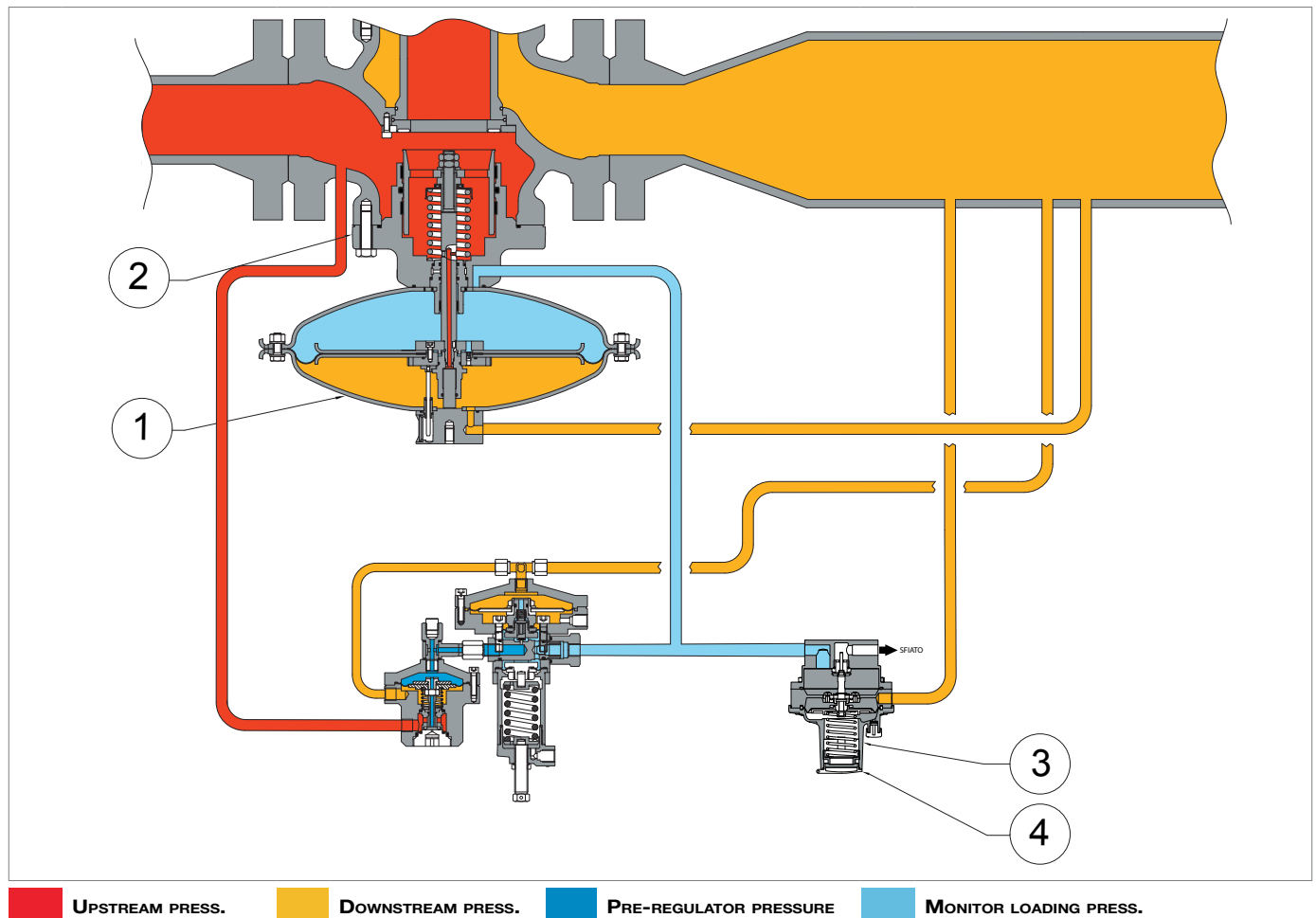

Fig. 4.9. V/25 throttle valve

Fig. 4.10 shows the M/A throttle valve.

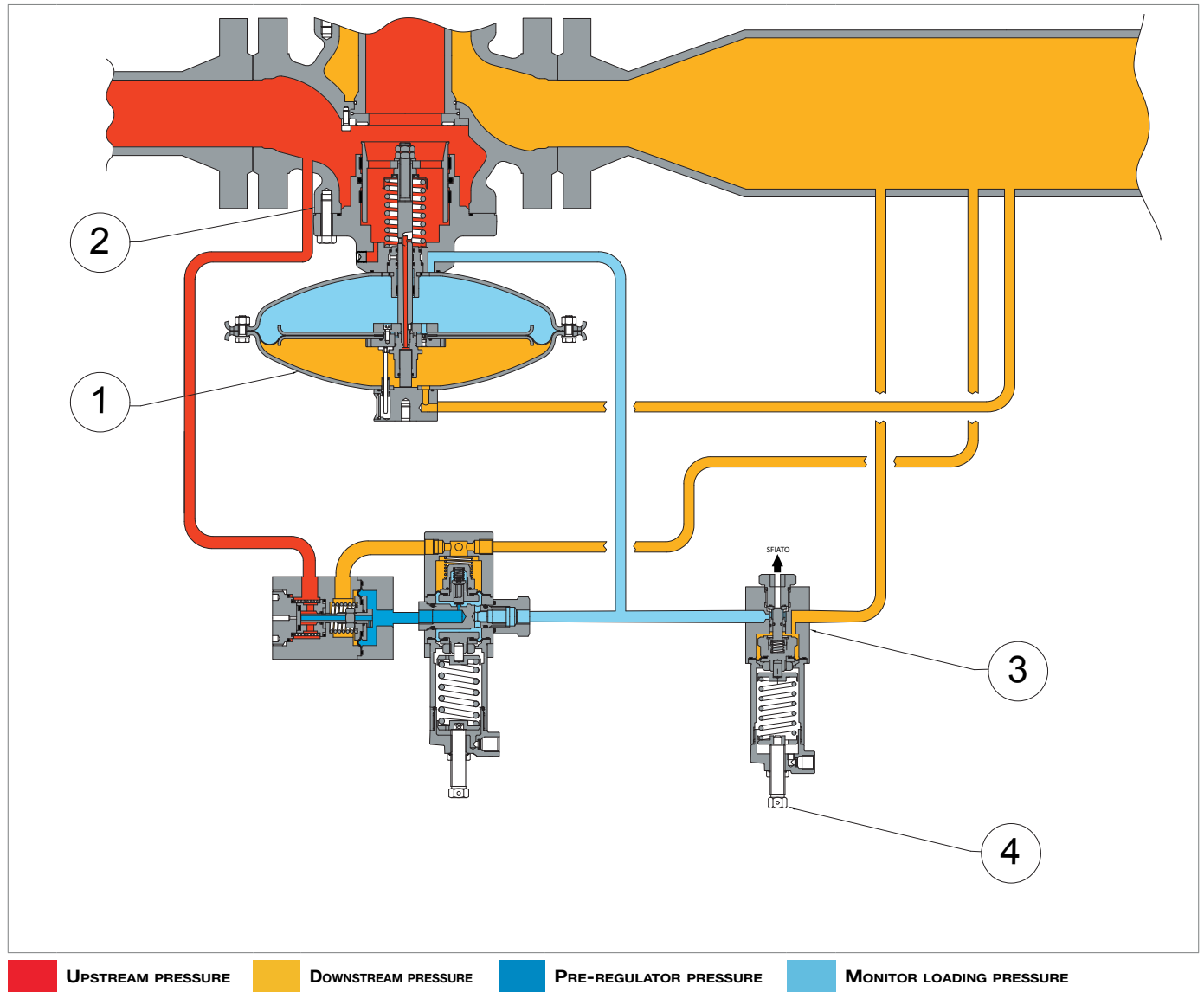

Fig. 4.10. M/A throttle valve

4.5.3 - SLAM-SHUT VALVE

The slam-shut valve is a safety device is used to shut off the gas flow if the pressure value at the control point exceeds the calibration value of the valve itself.

The slam-shut valve is incorporated in the main regulator of the equipment and consists of:

- a control system;
- the slam-shut device mechanism.

In the event of triggering, the slam-shut valve shuts off power supply to the regulator and its control pilot.

4.5.3.1 - BUILT-IN SLAM-SHUT VALVE SA

The SA built-in slam-shut valve is controlled by pressure switch mod. SA-91, SA-92, SA-93 and can be operated:

- by the pressure switch;
- manually;
- with remote control.

The main features of the SA built-in slam-shut valve are:

- tripping due to downstream pressure increase and/or decrease;
- design pressure: 18.9 bar for all accessory components;
- local shut-off button;
- rearming without the need for a bypass thanks to the balanced plug.

Pressure switch type	Set	Operating range (bar)	AG
SA/91	max	0.025 ÷ 1.1	10
SA/92	max	0.7 ÷ 2	10
	max	2 ÷ 5	5
SA-93	max	3 ÷ 4	10
	max	4 ÷ 13.3	5

Tab. 4.22.

* For the calibration values of the minimum spring, please refer to chapter 13 'Calibration tables'

The incorporated slam-shut valve SA consists of (see Fig. 4.11):

Pos.	Description
1	Plug
2	Control pressure switch
3	Reset system (manually operated through a lever)

Tab. 4.23.

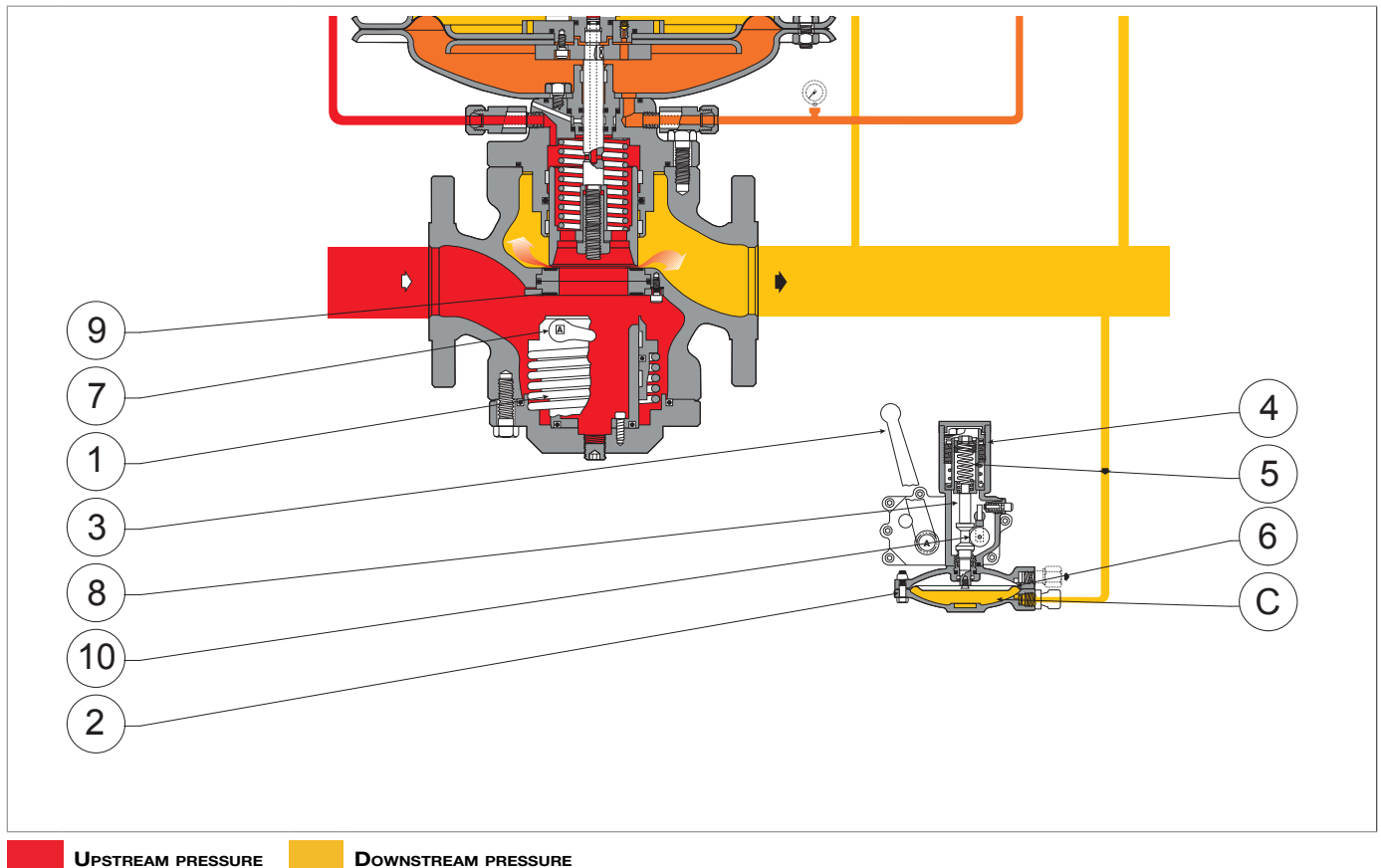

Fig. 4.11. Built-in slam-shut valve SA

OPERATION

In the control head (C), the downstream pressure (P_d) acts on the diaphragm (6) of the control pressure switch (2), which, integral with the control shaft (8), receives an antagonistic force through the springs (4, 5), which causes the plug (1) on the reinforced gasket (9) to disengage.

In the event of tripping due to a pressure surge:

- the downstream pressure (P_d) exceeds the calibration value;
- the load on the diaphragm (6) increases until the resistance of the spring (4) is overcome;
- the drive shaft (8) moves the feeler gauge (10), by means of the cam, to the opening position, releasing the lever mechanism.

In the event of tripping due to a pressure drop:

- the downstream pressure (P_d) decreases below the calibration value;
- the spring support (5) stops the stroke on the body stop;
- the drive shaft (8) moves the feeler gauge (10), by means of the cam, to the shut-off position, releasing the lever mechanism.

In order to reset the built-in slam-shut valve, the lever (3) that engages the control device (7) of the mobile system must be operated.

4.5.3.2 - SB/82 BUILT-IN SLAM-SHUT VALVE

The SB/82 built-in slam-shut valve can be operated:

- by the pressure switch;
- manually;
- with remote control.

The main features of the SB/82 built-in slam-shut valve are:

- tripping due to downstream pressure increase and/or decrease;
- design pressure: 100 bar for all accessory components;
- local shut-off button;
- manual reset only with internal bypass activated by the reset lever.

Pressure switch type	Set	Operating range (bar)	AG
Mod. 101M - 101MH	max	0.02 ÷ 1	5
	max	0.5 - 1	2.5
Mod. 102M - 102MH	max	0.2 - 5.5	5
Mod. 103M - 103MH	max	2 - 7	5
	max	7 - 22	2.5

Tab. 4.24.

* For the calibration values of the minimum spring, please refer to chapter 13 'Calibration tables'

The SB/82 incorporated slam-shut valve consists of (see Fig. 4.12):

Pos.	Description
1	Plug
2	Control pressure switch
3	Reset system (manually operated through a lever)

Tab. 4.25.

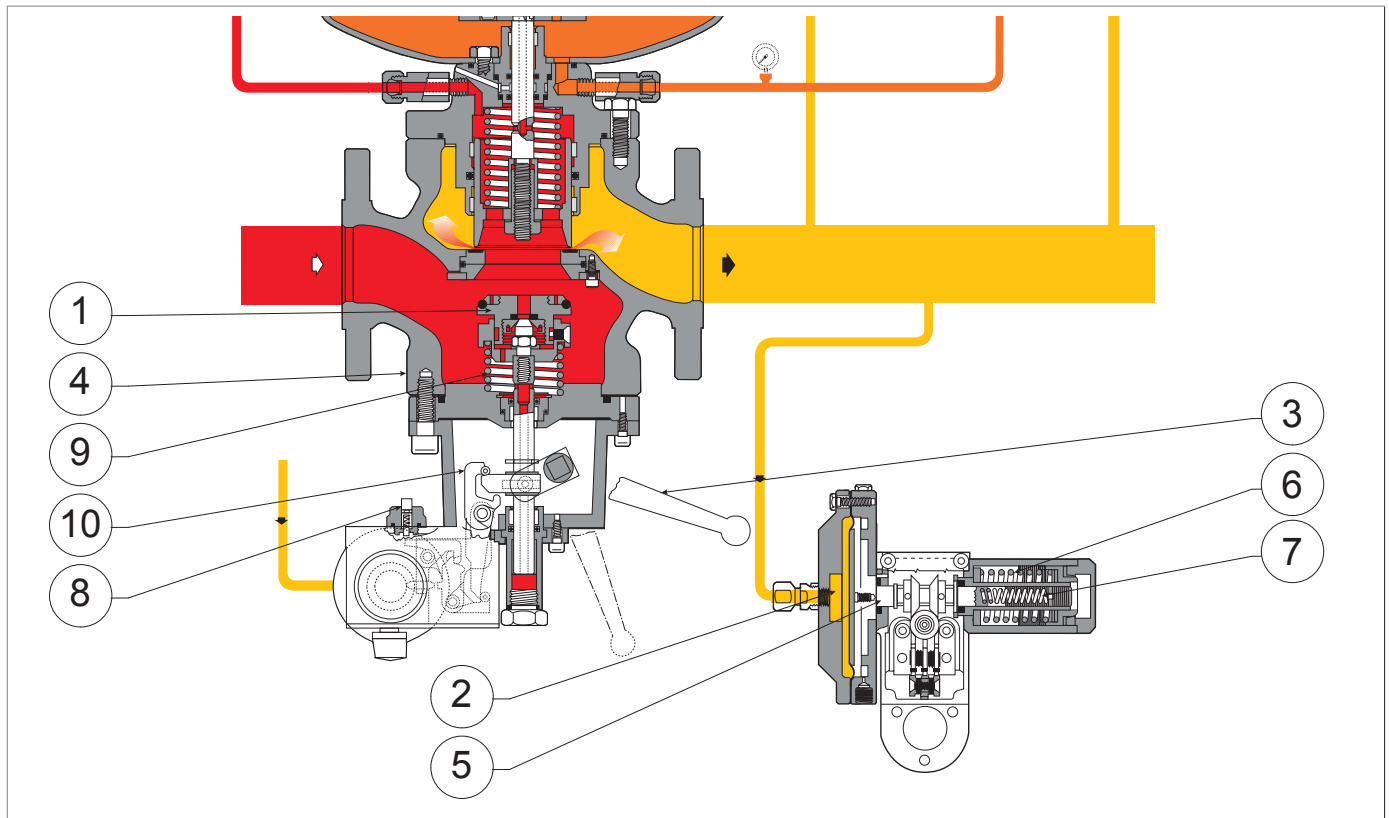

UPSTREAM PRESSURE

DOWNSTREAM PRESSURE

Fig. 4.12. REVAL 182 with SB/82 incorporated slam-shut valve

OPERATION:

The tripping pressure acts on the control element of the control pressure switch (2), which is solidly connected to the stem (5), and receives an antagonistic force through the springs due to maximum (7) and minimum (6) pressure tripping, calibrated to the pre-set values.

The translation of the stem (5) causes the control device (8) of the mobile system to be released and, through the action of the spring (9), the plug (1) to be shut off.

To reset the device, it is necessary to act on the lever (3) which:

- opens an internal bypass in the first section of the stroke allowing the upstream pressure to be transferred from the inlet chamber to the outlet chamber of the regulator body (4), thereby rebalancing the pressure on the plug (1);
- re-couples the control device (8) of the mobile system.

NOTICE!

The release of the control device (8) of the mobile system can also be controlled manually by means of a button (10).

4.5.3.3 - HB/97 BUILT-IN SLAM-SHUT VALVE

The built-in HB/97 incorporated slam-shut valve can be operated:

- by the pressure switch;
- manually;
- with remote control.

The main features of the HB/97 built-in slam-shut valve are:

- balanced valve plug;
- local shut-off button;
- tripping due to downstream pressure increase and/or decrease;
- built-in bypass;
- manual resetting only.

Pressure switch type	Set	Operating range (bar)	AG
Mod. 102M - 102MH	max	0.2 - 5.5	5
Mod. 103M - 103MH	max	2 - 7	5
	max	7 - 22	2.5

Tab. 4.26.

* For the calibration values of the minimum spring, please refer to chapter 13 'Calibration tables'

The HB/97 incorporated slam-shut valve consists of (see Fig. 4.13):

Pos.	Description
1	Balanced valve plug
2	LINE OFF 2.0 device

Tab. 4.27.

The LINE OFF 2.0 device (2) consists of (see Fig. 4.13):

Pos.	Description
4	HP2/2: filtering device of the gas supplying the control circuit; it also acts as a bypass necessary for resetting the built-in slam-shut valve HB/97.
5	R44/SS: pressure regulator necessary to decrease the upstream pressure of the regulator to the loading pressure of the HB/97 incorporated slam-shut valve cylinder.
6	AR100: flow throttle valve to adjust the pressure loading speed in the pneumatic circuit and to filter the gas entering the R44/SS regulator (6). <div style="border: 1px solid black; padding: 5px;">  NOTICE! The load speed is adjusted by a screw (minimum value 1, maximum value 8). </div>
7	VS/FI: safety valve used to: <ul style="list-style-type: none"> • discharge any overpressure generated by malfunction of the R44/SS pressure regulator into the atmosphere; • protect the entire circuit downstream of the R44/SS pressure regulator.
8	Valve 3/2: this device is used to pressurise and depressurise the cylinder of the HB/97 slam-shut valve.
9	Control pressure switch: through the control pressure switch head connected downstream, the HB/97 built-in slam-shut valve trips due to increased or decreased downstream pressure.

Tab. 4.28.

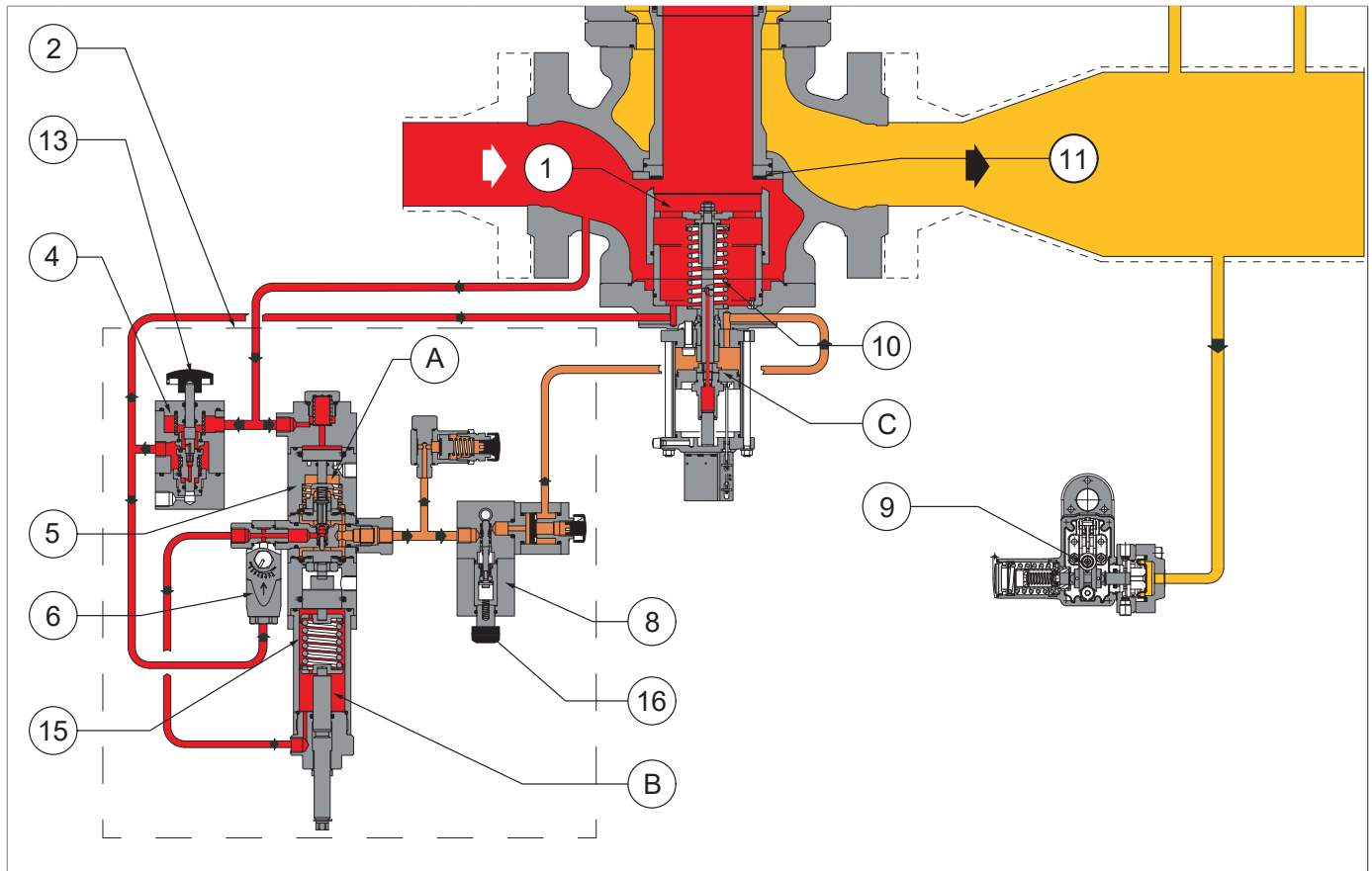

Fig. 4.13. REVAL 182 with HB/97 incorporated slam-shut valve

OPERATION:

At no pressure, the valve plug (1) is kept in the shut-off position by the spring (10) and rests on the reinforced gasket (11).

The upstream pressure (U_p) reaches the HP2/2 bypass device (4) and the upper head (A) of the R44/SS regulator (5) to prevent inappropriate resetting of the valve. By adjusting the activation button (13) of the bypass, the pressurised gas is filtered and feeds the AR100 throttle valve (6), which in turn supplies:

- the chamber of the adjustment spring (B);
- the R44/SS regulator (5), calibrated at a pressure of 4.5 bar to overcome the force of the shut-off spring (15) of the main valve.

Pressing the reset button (16) acts on the pressure switch coupling (9), so that the 3/2 valve (8) can be opened:

- pressurisation of the chamber (C) of the slam-shut valve by the R44/SS regulator (5);
- the plug opening (1).

In the event that the downstream pressure (P_d) increases or decreases, the pressure switch coupling (9) moves to:

- discharge the pressure from the chamber (C) into the atmosphere through the 3/2 valve (8);
- allow the spring (10) to bring the plug (1) to the shut-off position.

4.5.4 - SLAM-SHUT VALVE PRESSURE SWITCHES

The pressure switch is a control device consisting of (see Fig. 4.14):

Pos.	Description
1	Control element. NOTICE! The control element can be a diaphragm or a piston.
2	Stem.
3-4	Adjustment feeler gauges
5	Spring for maximum pressure tripping.
6	Spring for minimum pressure tripping.
7	UPSO minimum spring adjustment ring nut (6).
8	OPSO maximum pressure spring adjustment ring nut (5).
10	Manual release button.

Tab. 4.29.

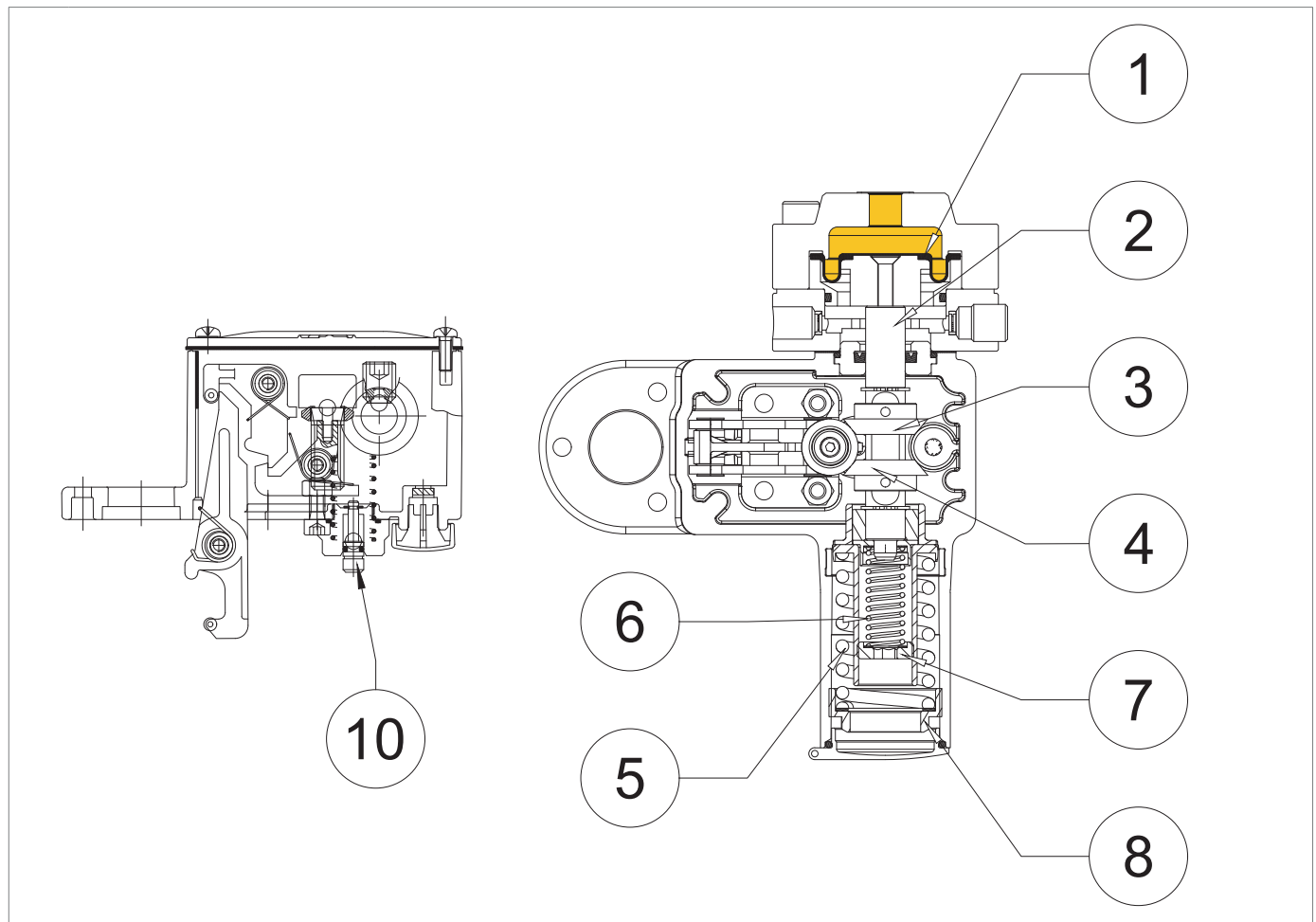

DOWNSTREAM PRESSURE

Fig. 4.14.

Slam-shut device pressure switch

Tab. 4.30 lists the models of possible pressure switches for this regulator:

Model pressure switch	Max [bar]	Min [bar]
101M	0.02 ÷ 1	0.01 ÷ 0.26
101MH	0.02 ÷ 1	-
102M	0.2 - 5.5	0.05 - 2.8
102MH	0.2 - 5.5	2.8 - 5.5
103M	2 - 22	0.2 - 8
103MH	2 - 22	8 - 19

Tab. 4.30.

PAGE INTENTIONALLY LEFT BLANK

5 - TRANSPORT AND HANDLING



5.1 - SPECIFIC WARNINGS FOR TRANSPORT AND HANDLING

NOTICE!

Transport and handling must be carried out by personnel:

- qualified (specially trained);
- who are familiar with accident prevention and workplace safety regulations;
- authorised to use lifting equipment and means;
- in compliance with the regulations in force in the country of destination of the equipment.

Transport with forklift or crane

Operator qualification	Person in charge of transport, handling, unloading and placing on site
PPE required	 <div style="background-color: #f4a460; padding: 5px; margin-top: 10px;">  WARNING! </div> <p>The PPE listed in this table is related to the risk associated with the equipment. For the required PPE to protect against risks associated with the workplace, installation or operating conditions, please refer to:</p> <ul style="list-style-type: none"> • the regulations in force in the country of installation; • <u>any information provided by the Safety Manager at the installation facility.</u>
Means of lifting	Hoist crane, forklift truck or other suitable equipment.
Weights and dimensions of the equipment	For dimensions and weights please refer to "5.2 - Physical characteristics of the equipment".

Tab. 5.31.

5.1.1 - PACKAGING AND FASTENERS USED FOR TRANSPORT

The transport packaging has been designed and manufactured to avoid damage during normal transport, storage and handling.

The equipment and spare parts must be kept in their packaging until they are installed.



Upon receiving the equipment:

- make sure that no part of the packaging has been damaged during transport and/or handling;
- immediately report any damage found to PIETRO FIORENTINI S.p.A..

! NOTICE!

PIETRO FIORENTINI S.p.A. shall not be liable for any damage to people or property caused by accidents due to failure to comply with the instructions provided in this manual.

Tab. 5.32 shows the types of packaging used:

Ref.	Type of packaging	Image
A	Cardboard box	
B	Wooden box	
C	Pallet	

Tab. 5.32.

PAGE INTENTIONALLY LEFT BLANK

5.2 - PHYSICAL CHARACTERISTICS OF THE EQUIPMENT

5.2.1 - REVAL 182 (+LDB/171)

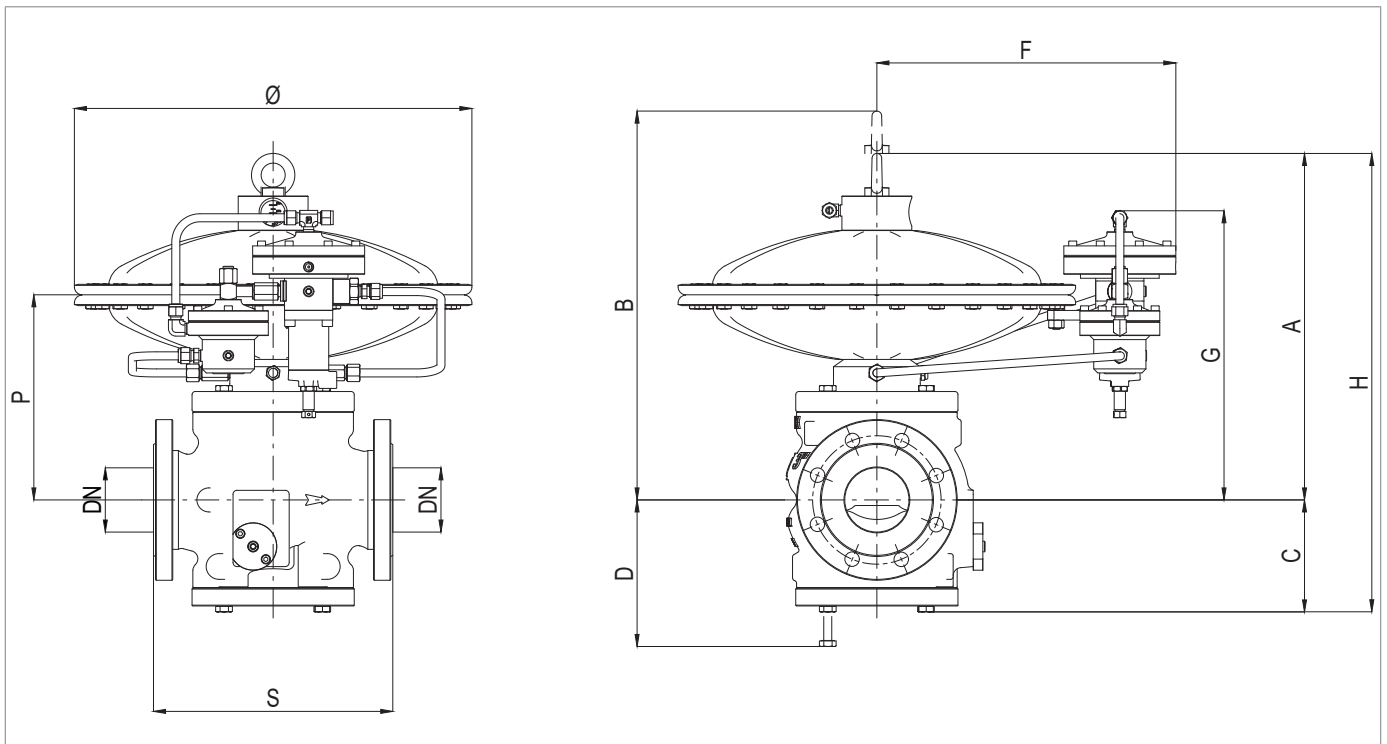

Fig. 5.15. Physical characteristics REVAL 182 (+LDB/171)

Overall dimensions REVAL 182 (+LDB/171)								
Nominal diameter [mm]	25	50	65	80	100	150	200	250
Size [inches]	1"	2"	2" 1/2	3"	4"	6"	8"	10"
S	183	254	276	298	352	451	546	673
Ø	375	375	495	495	495	630	630	630
A	320	350	430	430	470	550	650	770
B	410	430	530	530	600	735	850	760
C	100	130	140	150	190	220	260	310
D	130	160	180	200	250	270	315	398
F	350	350	410	410	410	475	475	470
G	250	285	330	340	370	400	450	550
H	430	480	570	580	660	770	910	1070
P	170	205	250	260	290	320	370	470
Pneumatic connections	Øe 10mm x Øi 8mm							

Tab. 5.33.

REVAL 182 (+LDB/171)								
Weight [kgf]	33	50	58	70	110	195	300	580

Tab. 5.34.

5.2.2 - REVAL 182 + DB/182

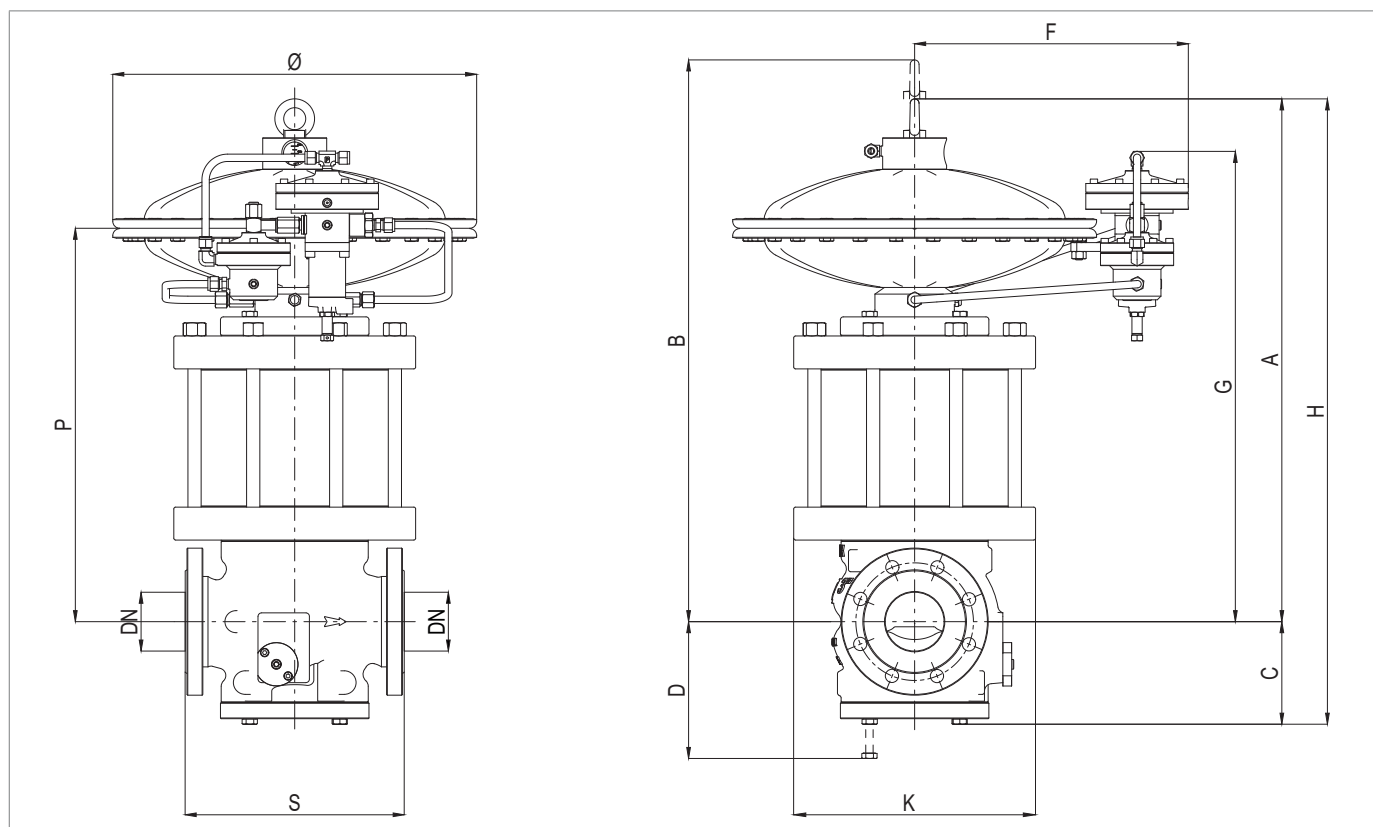

Fig. 5.16. REVAL 182 + DB/182 physical characteristics

REVAL 182 + DB/182 overall dimensions								
Nominal diameter [mm]	25	50	65	80	100	150	200	250
Size [inches]	1"	2"	2" 1/2	3"	4"	6"	8"	10"
S	183	254	276	298	352	451	543	673
Ø	375	375	495	495	495	630	630	630
A	520	550	650	675	755	920	1050	1262
B	610	640	780	785	895	1120	1250	1450
C	100	130	140	150	190	220	260	310
D	130	160	180	200	250	270	315	398
F	350	350	410	410	410	475	475	470
G	450	480	550	585	655	770	850	1040
H	820	850	965	1010	1115	1350	1525	1575
K	370	400	470	505	575	690	770	700
P	215	295	325	325	390	470	600	960
Pneumatic connections	Øe 10mm x Øi 8mm							

Tab. 5.35.

REVAL 182 + DB/182								
Weight [kgf]	44	84	88	112	178	339	536	900

Tab. 5.36.

5.2.3 - REVAL 182 + PM/182

Fig. 5.17. REVAL 182 + PM/182 physical characteristics

REVAL 182 + PM/182 overall dimensions

Nominal diameter [mm]	25	50	65	80	100	150	200
Size [inches]	1"	2"	2" 1/2	3"	4"	6"	8"
S	183	254	276	298	352	451	543
Ø	375	375	495	495	495	630	630
A	320	350	430	430	470	550	650
B	410	430	530	530	600	735	850
C	260	290	370	380	410	490	590
D	410	430	530	530	600	735	850
F	350	350	410	410	410	475	475
G	250	285	330	340	370	400	450
H	640	700	860	860	940	110	1300
M	260	295	340	350	380	410	460
P	170	205	250	260	290	320	370
Pneumatic connections	Øe 10mm x Øi 8mm						

Tab. 5.37.

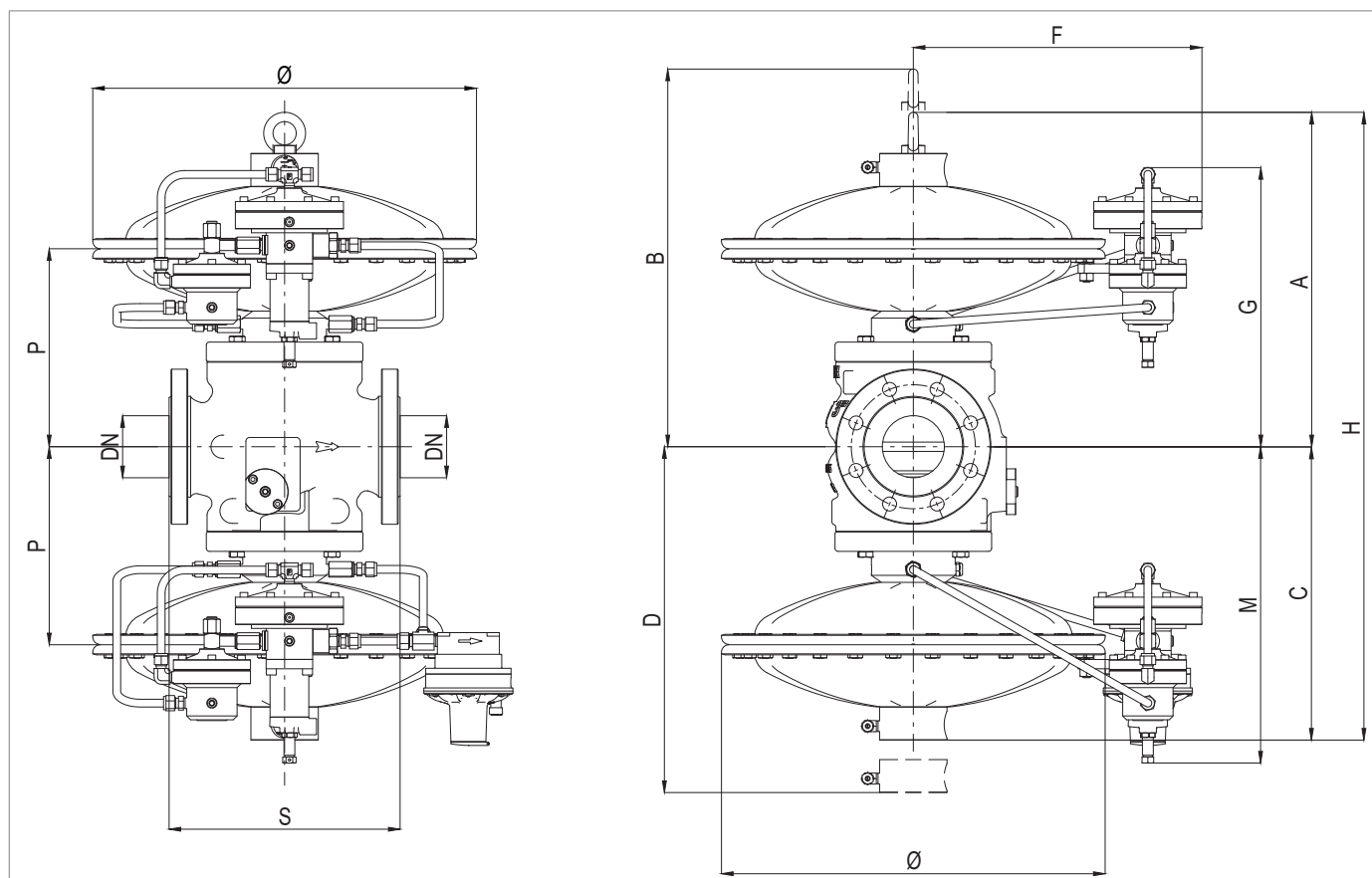
REVAL 182 + PM/182

Weight [kgf]	54	75	85	100	150	255	395
--------------	----	----	----	-----	-----	-----	-----

Tab. 5.38.

5.2.4 - REVAL 182 + SA

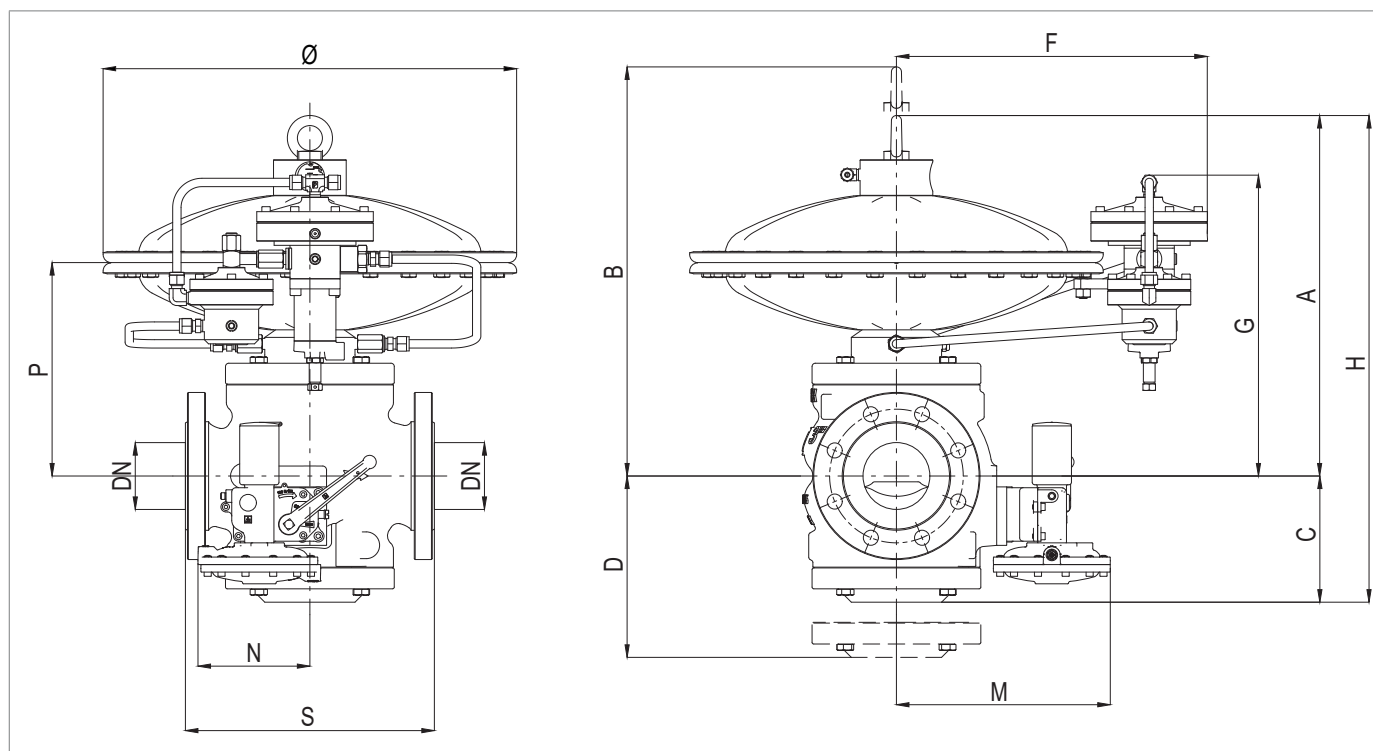

Fig. 5.18. Physical characteristics REVAL 182 + SA

Overall dimensions REVAL 182 + SA					
Nominal diameter [mm]	25	50	65	80	100
Size [inches]	1"	2"	2" 1/2	3"	4"
S	183	254	276	298	352
Ø	375	375	495	495	495
A	320	350	430	430	470
B	410	430	530	530	600
C	145	161	178	185	205
D	212	255	292	322	330
F	350	350	410	410	410
G	250	285	330	340	370
H	465	511	608	615	874
L	98	146	146	146	146
M	194	219	232	246	263
N	125	125	125	125	130
P					
Pneumatic connections	Øe 10mm x Øi 8mm				

Tab. 5.39.

REVAL 182 + SA					
Weight [kgf]	35	52	60	72	113

Tab. 5.40.

5.2.5 - REVAL 182 + SB/82

Fig. 5.19. Physical characteristics REVAL 182 + SB/82

Overall dimensions REVAL 182 + SB/82

Nominal diameter [mm]	25	50	65	80	100	150	200	250
Size [inches]	1"	2"	2" 1/2	3"	4"	6"	8"	10"
S	183	254	276	298	352	451	543	673
Ø	375	375	495	495	495	630	630	630
A	320	350	430	430	470	550	650	770
B	410	430	530	530	600	735	850	760
C	300	300	315	335	360	430	475	550
D	390	390	425	445	500	615	695	800
F	350	350	410	410	410	475	475	470
G	250	285	330	340	370	400	450	550
H	620	650	745	765	830	980	1125	1320
P	170	205	250	260	290	320	370	470
Pneumatic connections	Øe 10mm x Øi 8mm							

Tab. 5.41.

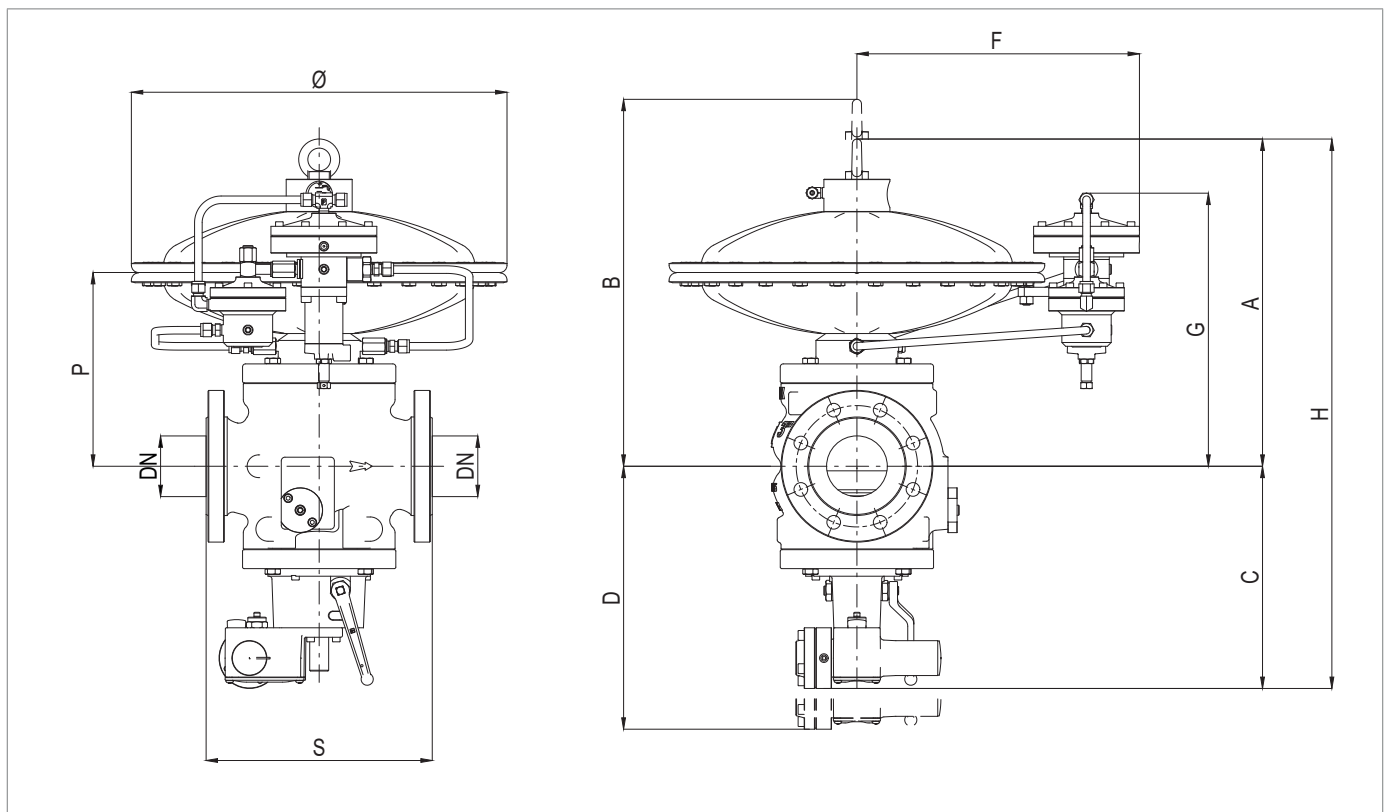
REVAL 182 + SB/82

Weight [kgf]	45	56	70	88	132	246	354	680
--------------	----	----	----	----	-----	-----	-----	-----

Tab. 5.42.

5.2.6 - REVAL 182 + HB/97

Fig. 5.20. Physical characteristics REVAL 182 + HB/97

Overall dimensions REVAL 182 + HB/97				
Nominal diameter [mm]	100	150	200	250
Size [inches]	4"	6"	8"	10"
S	352	451	543	673
Ø	495	630	630	630
A	470	550	650	770
B	600	735	850	760
C with HB/97	518	645	687	796
D with HB/97	650	835	900	1060
F	410	475	475	470
F1	358	410	445	510
G	370	400	450	550
H with HB/97	988	1195	1337	1566
P	290	320	370	470
Pneumatic connections				

Tab. 5.43.

REVAL 182 + HB/97				
Weight [kgf]	122	236	308	624

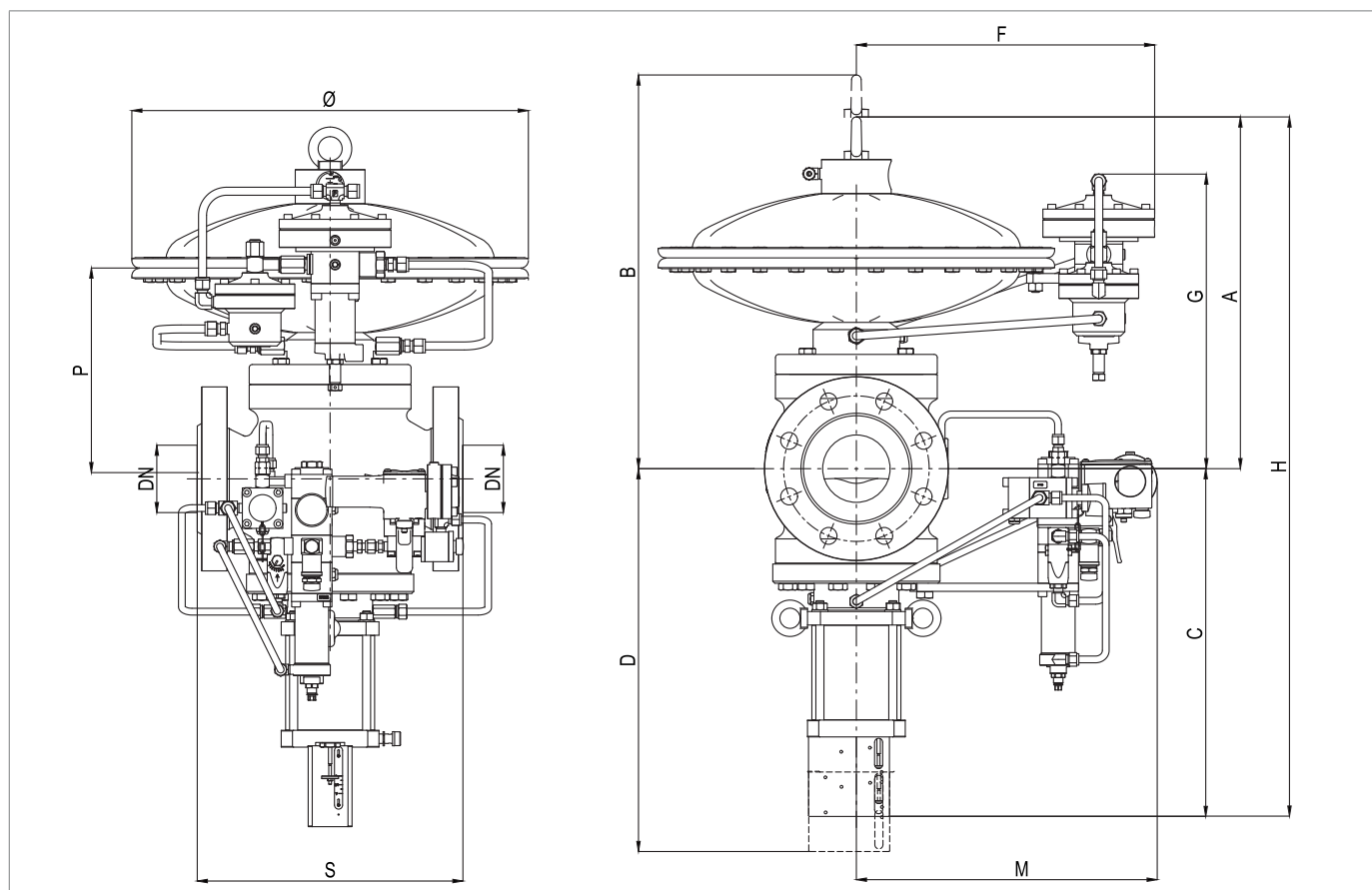
Tab. 5.44.

5.2.7 - REVAL 182 + DB/182 + PM/182

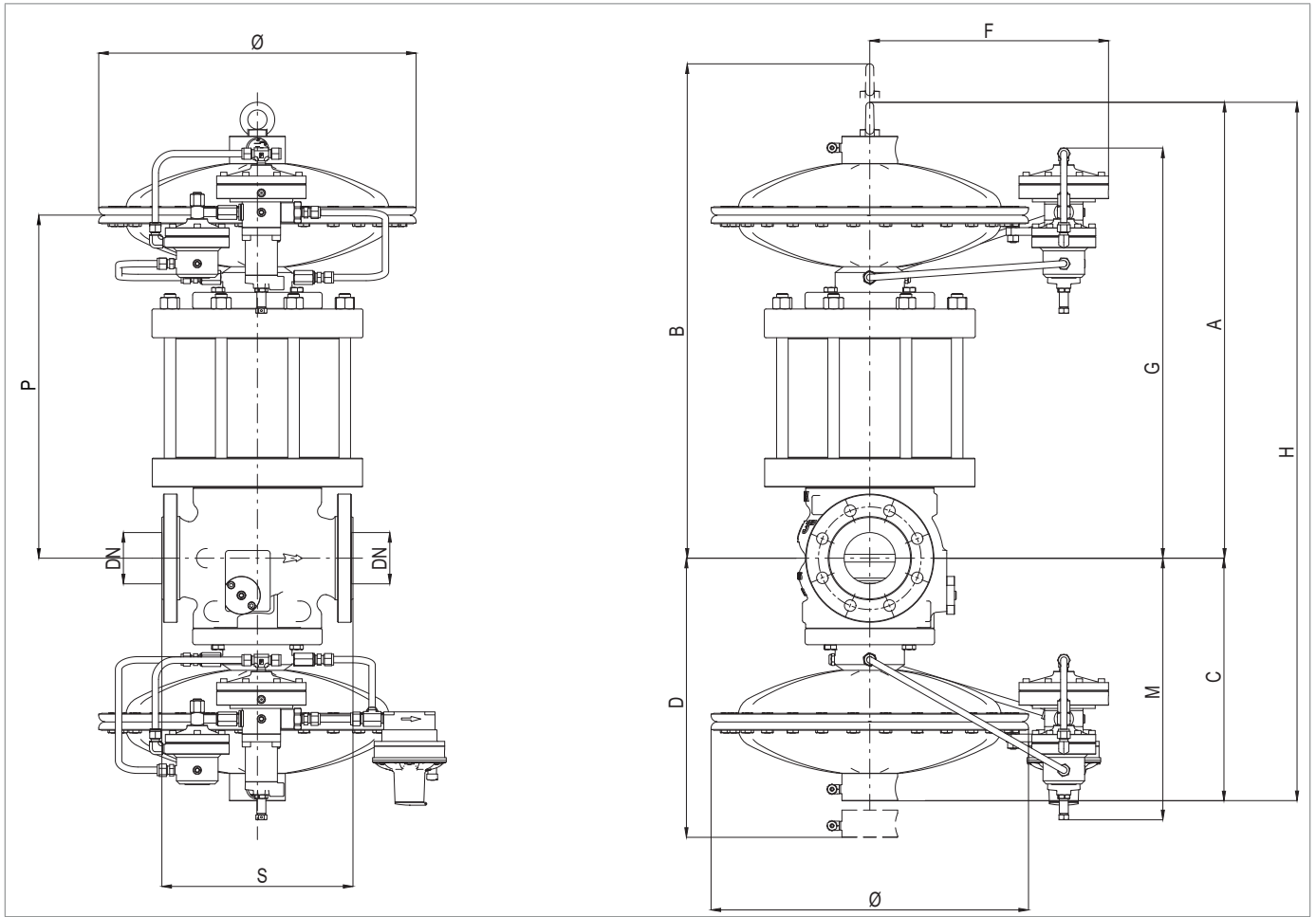

Fig. 5.21. REVAL 182 + DB/82 + PM/182 physical characteristics

REVAL 182 + DB/182 + PM/182 overall dimensions							
Nominal diameter [mm]	25	50	65	80	100	150	200
Size [inches]	1"	2"	2" 1/2	3"	4"	6"	8"
S	183	254	276	298	352	451	543
Ø	375	375	495	495	495	630	630
A	520	550	650	675	755	920	1050
B	610	640	780	785	895	1120	1250
C	260	290	370	380	410	490	590
D	410	430	530	530	600	735	850
F	350	350	410	410	410	475	475
G	450	480	550	585	655	770	850
H	780	840	1020	1055	1165	1410	1640
K	215	295	325	325	390	470	600
L	260	295	340	350	380	410	460
P	370	400	470	505	575	690	770
Pneumatic connections	Øe 10mm x Øi 8mm						

Tab. 5.45.

REVAL 182 + DB/182 + PM/182							
Weight [kgf]	65	109	115	142	218	399	631

Tab. 5.46.

5.2.8 - REVAL 182 + DB/182 + SA

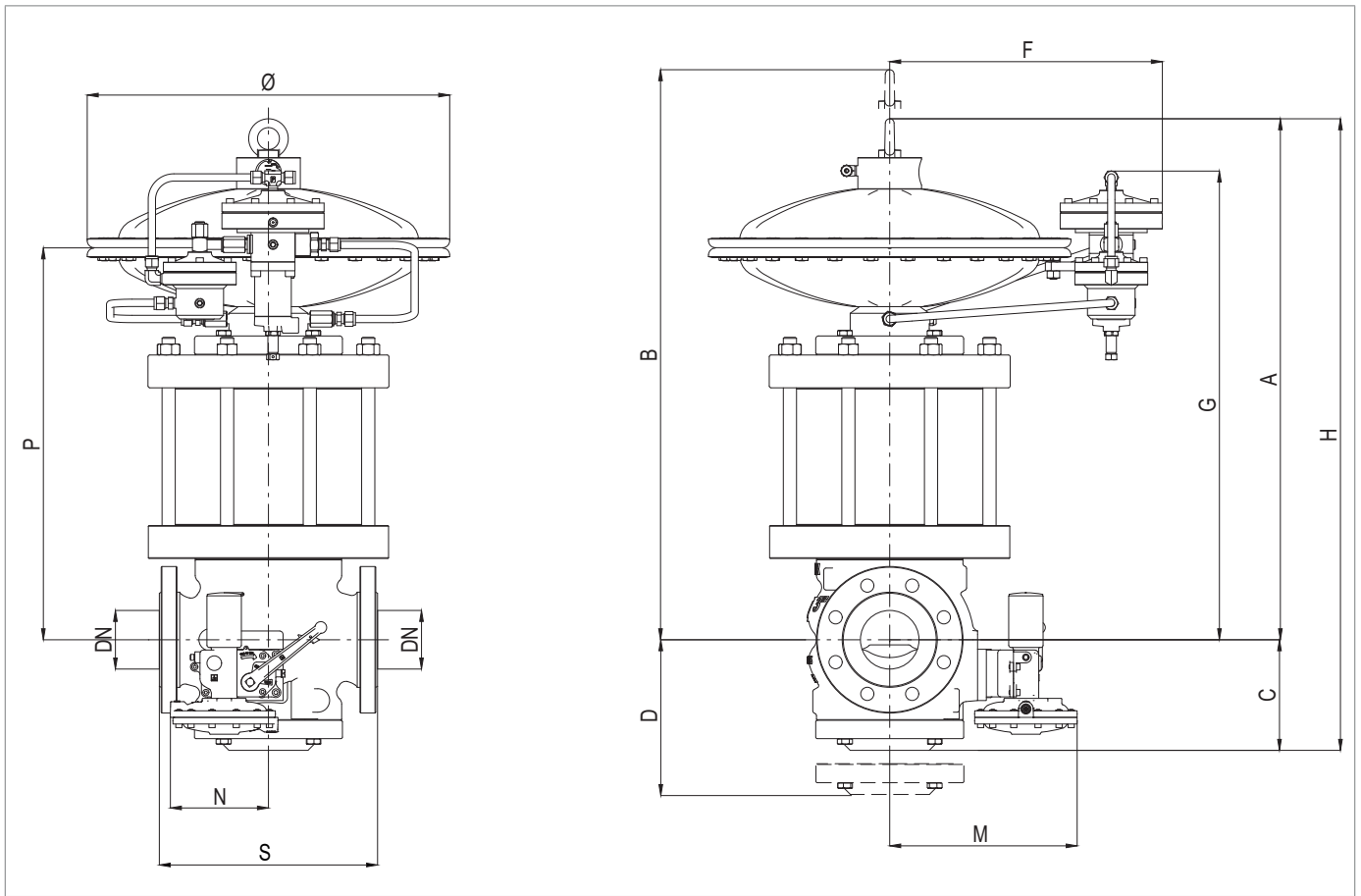

Fig. 5.22. Physical characteristics REVAL 182 + DB/182 + SA

Overall dimensions REVAL 182 + DB/182 + SA					
Nominal diameter [mm]	25	50	65	80	100
Size [inches]	1"	2"	2" 1/2	3"	4"
S	183	254	276	298	352
Ø	375	375	495	495	495
A	520	550	650	675	755
B	610	640	780	785	895
C	145	161	178	185	404
D	212	255	292	322	636
F	350	350	410	410	410
G	250	480	550	585	655
H	465	511	608	615	874
K	215	295	325	325	390
L	98	146	146	146	146
M	194	219	232	246	263
N	125	125	125	130	130
P	370	400	470	505	575
Pneumatic connections	Øe 10mm x Øi 8mm				

Tab. 5.47.

REVAL 182 + DB/182 + SA					
Weight [kgf]	35	52	60	72	113

Tab. 5.48.

5.2.9 - REVAL 182 + DB/182 + SB/82

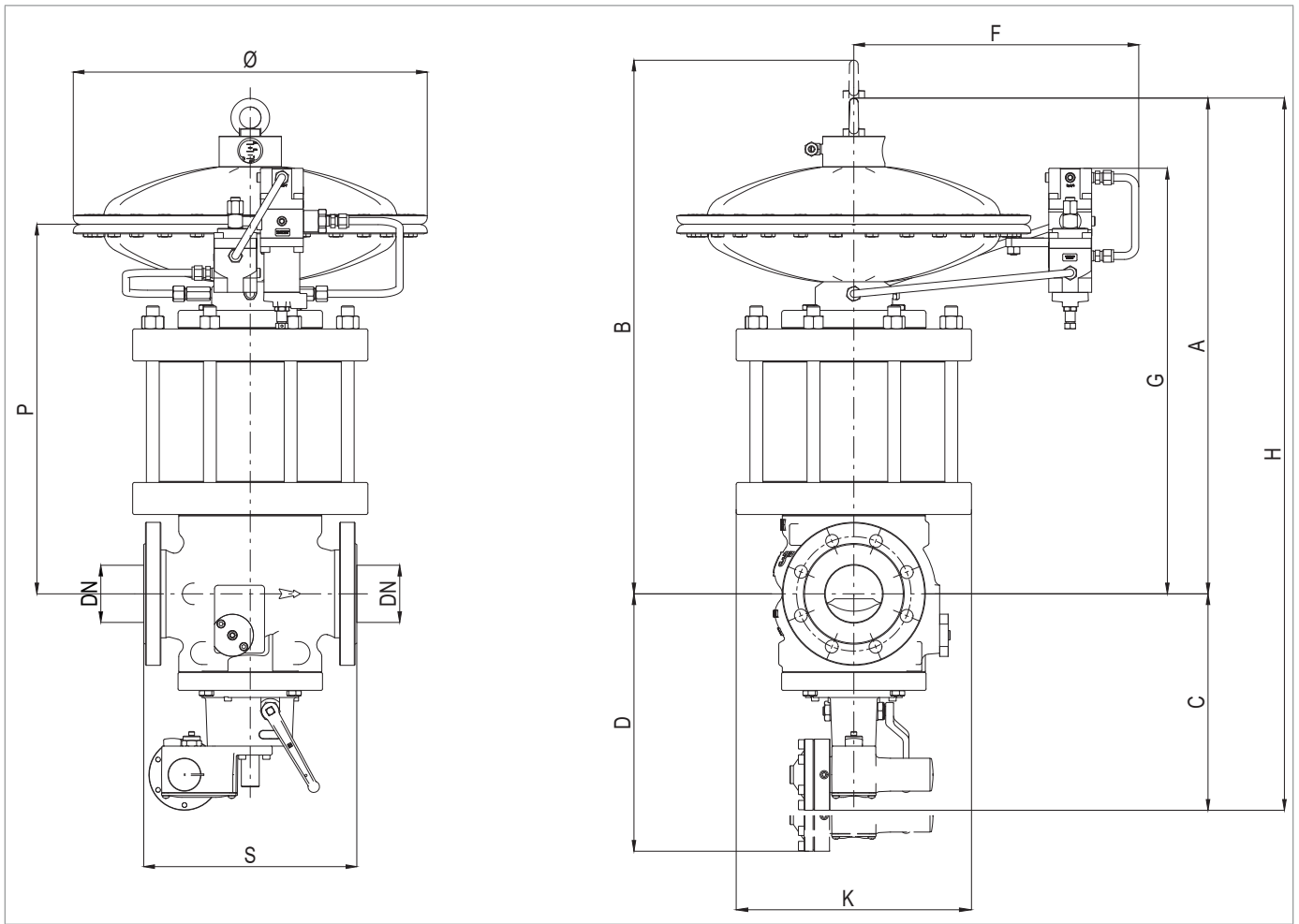

Fig. 5.23. Physical characteristics REVAL 182 + DB/182 + SB/82

Overall dimensions REVAL 182 + DB/182 + SB/82								
Nominal diameter [mm]	25	50	65	80	100	150	200	250
Size [inches]	1"	2"	2" 1/2	3"	4"	6"	8"	10"
S	183	254	276	298	352	451	543	673
Ø	375	375	495	495	495	630	630	630
A	520	550	650	675	755	920	1050	1262
B	610	640	780	785	895	1120	1250	1450
C	300	300	315	335	360	430	475	550
D	390	390	425	445	500	615	695	800
F	350	350	410	410	410	475	475	470
G	250	480	550	585	655	770	850	1040
H	820	850	965	1010	1115	1350	1525	1812
P	370	400	470	505	575	690	770	700
Pneumatic connections	Øe 10mm x Øi 8mm							

Tab. 5.49.

REVAL 182 + DB/182 + SB/82								
Weight [kgf]	56	90	100	130	200	390	590	1000

Tab. 5.50.

5.2.10 - REVAL 182 + DB/182 + HB/97

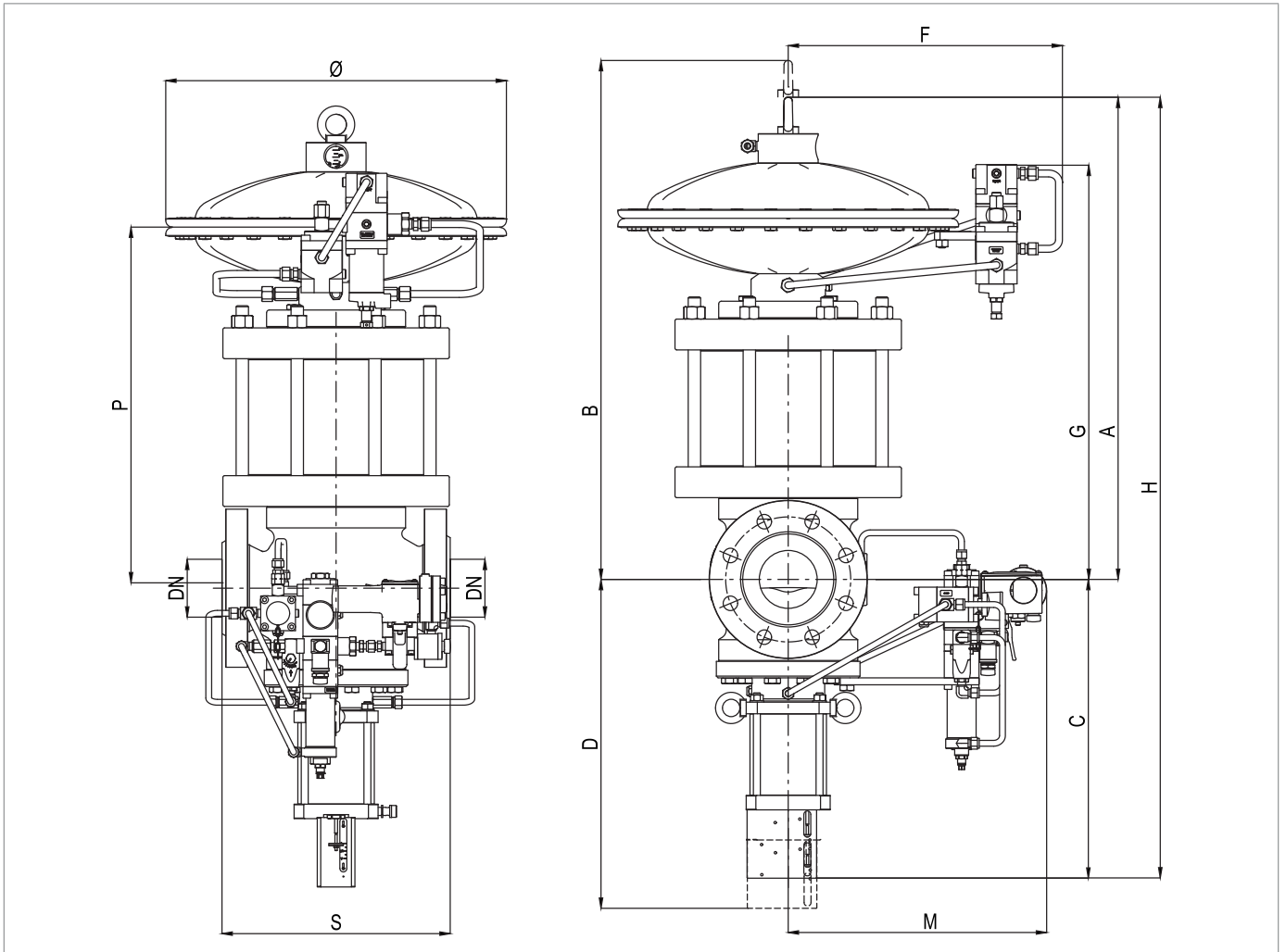

Fig. 5.24. Physical characteristics REVAL 182 + DB/182 + HB/97

Overall dimensions REVAL 182 + DB/182 + HB/97				
Nominal diameter [mm]	100	150	200	250
Size [inches]	4"	6"	8"	10"
S	352	451	543	673
Ø	495	630	630	630
A	755	920	1050	1262
B	895	1120	1250	1450
C	518	645	687	796
D	650	835	900	1060
F	410	475	475	470
G	655	770	850	1040
H	650	835	900	1060
P	575	690	770	700
Pneumatic connections				

Tab. 5.51.

REVAL 182 + DB/182 + HB/97				
Weight [kgf]	196	380	534	944

Tab. 5.52.

5.3 - EQUIPMENT ANCHORING AND LIFTING METHOD

 **HAZARD!**

Before handling the equipment, make sure that the capacity of the lifting equipment is suitable for the load.

 **WARNING!**

Unloading, transport and handling activities must be carried out by operators qualified and specially trained:

- on accident prevention rules;
- on maximum safety in the workplace;
- on the use of lifting equipment.

 **ATTENTION!**

Before handling the equipment:

- remove any movable or hanging component or firmly secure it to the load;
- protect the most fragile equipment;
- check that the load is stable.

5.3.1 - FORKLIFT HANDLING METHOD

HAZARD!

It is forbidden to:

- transit under suspended loads;
- move the load over the personnel operating in the site/plant area.

WARNING!





The following is not allowed on forklifts:

- carrying passengers;
- lifting people.

NOTICE!

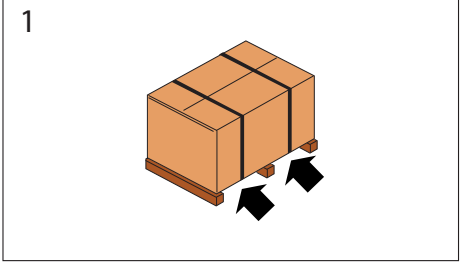
Packaging must be always handled in a vertical position

Proceed as described at Tab. 5.53:

Step	Action	Image
1	Place the forks of the forklift under the load surface.	
2	Make sure that the forks protrude from the front of the load (by at least 5 cm), far enough to eliminate any risk of the transported load tipping.	
3	Raise the forks until they are touching the load. NOTICE! Fasten the load to the forks with clamps or similar devices if required.	
4	Slowly lift the load by a few dozen centimetres and check its stability, making sure that the centre of gravity of the load is at the centre of the lifting forks.	

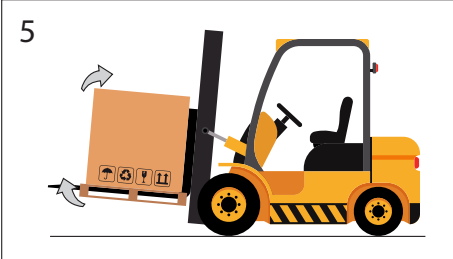
Step	Action	Image
5	Tilt the mast backwards (towards the driver's seat) to help the over-turning moment and to ensure greater load stability during transport.	
6	Adjust transport speed according to the type of floor and load, avoiding jerky movements. ⚠ WARNING! If: <ul style="list-style-type: none"> • obstacles along the path; • particular operating situations; hinder operator visibility, the assistance of a ground operator is required, standing outside the range of action of the lifting equipment, with the task of signalling.	-
7	Place the load in the chosen installation area.	-

Tab. 5.53.

5.3.2 - CRANE HANDLING METHOD

WARNING!

It is mandatory to use CE marked chains, ropes and eyebolts or marked with conformity marks/markings in accordance with the regulations in force in the place of installation. Do not use chains connected to each other by bolts.

Always check that:

- the safety catch of the hook returns to the initial position;
- the ropes are in excellent condition and have adequate sections.



It is forbidden to:

- drag the load on the ground;
- operate near power lines;
- stand within the range of action of the crane.

NOTICE!

Packaging must be always handled in a vertical position.

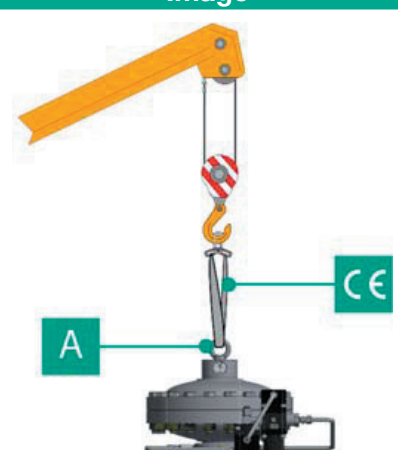
The equipment must be handled using the lifting points provided on the equipment itself. For proper transport, follow the procedure in Tab. 5.54:

Step	Action	Image
1	Attach the lifting rope or chain to the appropriate supports.  WARNING! The lifting point is sized for lifting only the equipment, and not other parts of the system connected to it.	
2	Slightly lift the load making sure the ropes or chains are secure.  NOTICE! Check whether the load is properly balanced.	
3	Handle the load avoiding sudden movements.	
4	Place the load in the chosen installation area.	

Tab. 5.54.

5.4 - PACKAGING REMOVAL

Packaging removal	
Operator qualification	<ul style="list-style-type: none"> Person in charge of transport, handling, unloading and placing on site; Installer.
PPE required	<div style="display: flex; align-items: center;">  </div> <div style="background-color: #f4a460; padding: 5px; margin-top: 5px;"> ⚠ WARNING! </div> <p>The PPE listed in this table is related to the risk associated with the equipment. For the PPE necessary to protect against risks associated with the workplace or operating conditions, please refer to:</p> <ul style="list-style-type: none"> the regulations in force in the country of installation; <u>any information provided by the Safety Manager at the installation facility.</u>

Tab. 5.55.

To unpack the equipment in a cardboard box, proceed as described in Tab. 5.56:

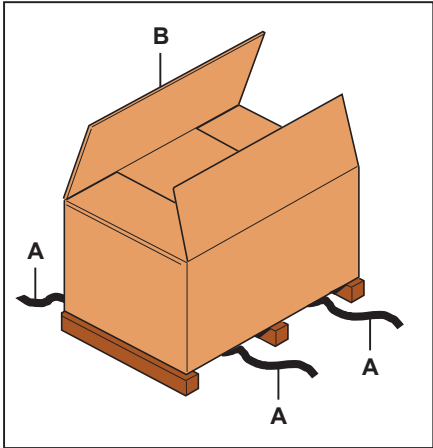
Step	Action	Image
1	Remove the straps (A).	
2	Remove the packaging cardboard (B).	
3	Remove the fasteners that secure the equipment to the base (if any).	
4	Move the equipment from the base to the place intended for it. <div style="border: 1px solid blue; padding: 5px; margin-top: 5px;"> ⚠ NOTICE! Have at least 2 operators manually move the equipment, if required due to its dimensions/weight. </div>	

Tab. 5.56.

⚠ NOTICE!

After removing all packaging materials, check for any anomalies.

If there are anomalies:

- do not install the equipment;
- contact PIETRO FIORENTINI S.p.A. and specify the details provided on the equipment rating plate.

5.4.1 - PACKAGING DISPOSAL

⚠ NOTICE!

Sort the various materials making up the packaging and dispose of them in compliance with the regulations in force in the country of installation.

5.5 - STORAGE AND ENVIRONMENTAL CONDITIONS

If the equipment needs to be stored for an extended period, the minimum environmental conditions for the intended storage are provided. Only by complying with these requirements can the declared performance be guaranteed:

Conditions	Data
Maximum storage period	Maximum 3 years. <div style="border: 1px solid blue; padding: 5px;">  NOTICE! For installations in later periods, see paragraph “pre-installation warnings after prolonged storage.” </div>
Temperature	Not above 40°C
Humidity	Not above 70%
Radiation	Away from radiation sources according to UNI ISO 2230:2009

Tab. 5.57.

5.5.1 - PRE-INSTALLATION WARNINGS AFTER PROLONGED STORAGE

For installations that have been stored for longer than 3 years, the condition of all rubber parts must be checked and, if found to be damaged, they must be replaced in order to ensure the correct functioning of the equipment.

For the replacement of the rubber parts of the equipment, please refer to chapter “9 - Maintenance and functional checks”.

<div style="border: 1px solid blue; padding: 5px;">  NOTICE! PIETRO FIORENTINI S.p.A. recommends checking the condition of rubber parts in case of downtime or storage longer than 3 years. </div>

PAGE INTENTIONALLY LEFT BLANK

6 - INSTALLATION

6.1 - INSTALLATION PRE-REQUISITES

6.1.1 - ENVIRONMENTAL CONDITIONS ALLOWED

WARNING!

To safely use the equipment, in full respect of the allowed environmental conditions, follow the data shown on the regulator plate and on any accessories (refer to paragraph “2.8 - Applied rating plates”).

The installation site must be suitable for the safe use of the equipment.

The equipment installation area must have lighting that guarantees the operator good visibility during the work phases on the equipment.

NOTICE!

The equipment must operate in places that are properly lit by artificial lighting suitable for the protection of the operator (in compliance with UNI EN 12464-1:2011 and UNI EN 12464-2:2014). If maintenance work is to be performed in areas and/or parts that are poorly lit, it is mandatory to:

- use all the light sources of the installation plant;
- be equipped with a handheld lighting system or connected to the power mains, compliant with Directive 2014/34/EU (ATEX) for use in environments at risk of explosion.

6.1.2 - CHECKS BEFORE INSTALLATION

The device does not require any further upstream safety device for protection against any overpressure with respect to its **PS admissible pressure** when, for the upstream reduction station, the maximum incidental downstream pressure is:

$$\text{MIPd} \leq 1.1 \text{ PS}$$

MIPd = Maximum incidental downstream pressure value (for further information, see UNI EN 12186:2014).

ATTENTION!

If the installation of the equipment requires the application of compression fittings, these must be installed in accordance with the instructions of the Manufacturer of the fittings themselves.



The choice of fittings must be compatible with:

- **the use specified for the equipment;**
- **the plant specifications when required.**

Before installation, it must be ensured that:

- the expected dimensions of the installation site are compatible with those of the equipment;
- there are no impediments for the workers in charge of maintenance;
- the upstream and downstream pipes are at the same level and can bear the weight of the equipment;
- the inlet and outlet connections of the pipes are aligned on the flanges;
- the inlet and outlet connections of the equipment are clean and intact;
- the inside of the upstream pipe is clean and free of processing residues such as welding slag, sand, paint residues, water, etc...

Installation

Operator qualification	Installer
PPE required	 <p> WARNING!</p> <p>The PPE listed in this table is related to the risk associated with the equipment. For the required PPE to protect against risks associated with the workplace, installation or operating conditions, please refer to:</p> <ul style="list-style-type: none"> • the regulations in force in the country of installation; • any information provided by the Safety Manager at the installation facility.
Equipment required	Please refer to the chapter "7 - Commissioning/maintenance equipment".

Tab. 6.58.

6.2 - SPECIFIC SAFETY INSTRUCTIONS FOR THE INSTALLATION PHASE

 **WARNING!**

Before proceeding with installation, make sure that the upstream and downstream valves installed on the line are shut off.

 **WARNING!**

Installation may also take place in areas where there is a risk of explosion, which implies that all necessary prevention and protection measures have to be taken.

For these measures, please refer to the regulations in force at the place of installation.

6.3 - GENERAL INFORMATION ON CONNECTIONS

The equipment must be installed in-line with an arrow on the body pointing to the gas flow direction. They must be present in the online installation (see Fig. 6.25 and Fig. 6.26):

Pos.	Description
1	1 slam shut valve upstream of the equipment
2	2 vent valves set up one upstream and one downstream of the equipment.
3	2 pressure gauges set up one upstream and one downstream of the equipment.
4	1 pressure regulator .
5	1 shut-off valve downstream of the equipment.

Tab. 6.59.

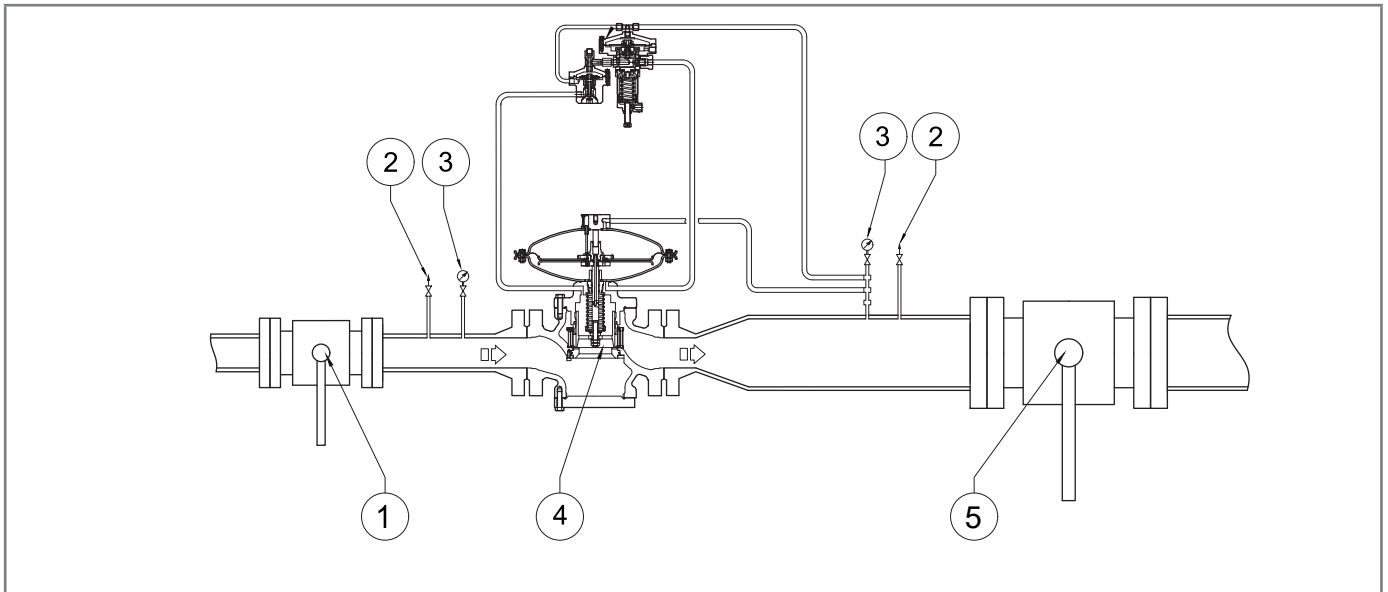

Fig. 6.25. Inline installation

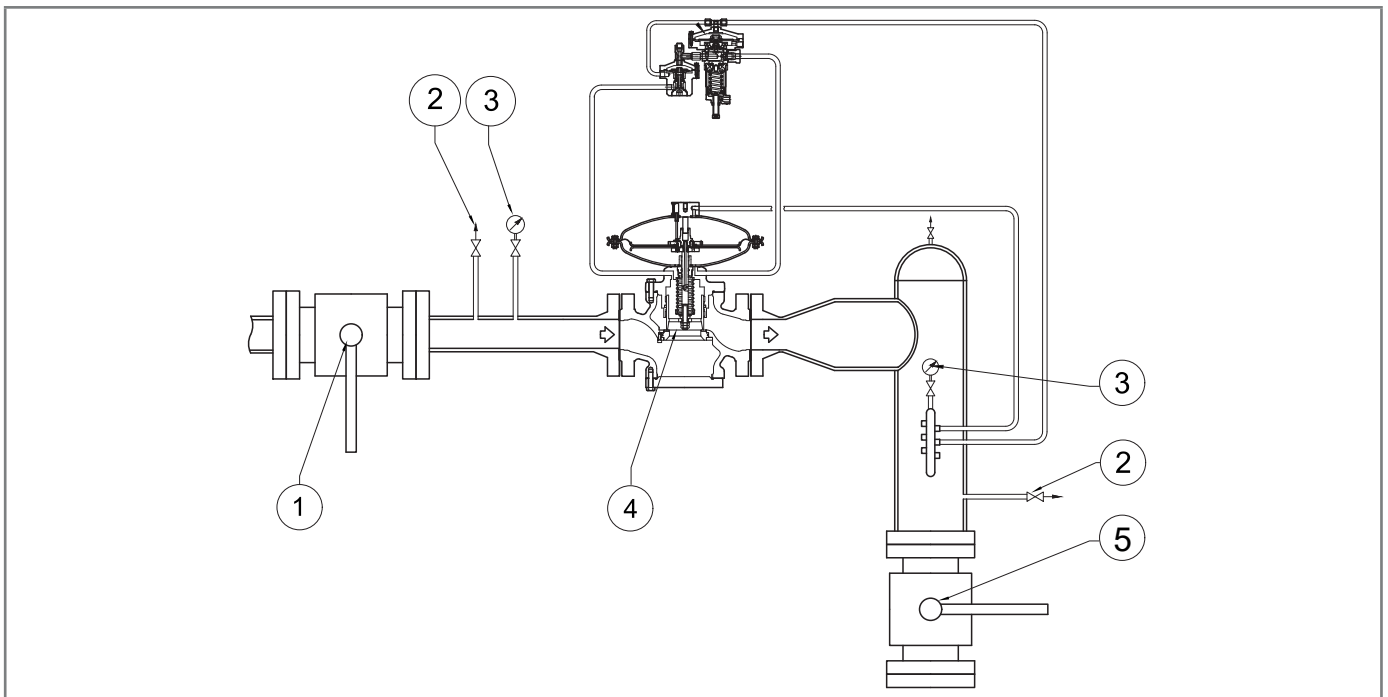

Fig. 6.26. Angle installation

! NOTICE!

When used in gas pressure reduction stations, the device must be installed at least according to the requirements of standards UNI EN 12186:2014 or UNI EN 12279:2007.

Equipment vents must be ducted in accordance with UNI EN 12186:2014 or UNI EN 12279:2007 or the standards in force at the place of installation of the equipment.

6.4 - REGULATOR INSTALLATION POSITIONS

Fig. 6.27 and Fig. 6.28 illustrate typical regulator arrangements:

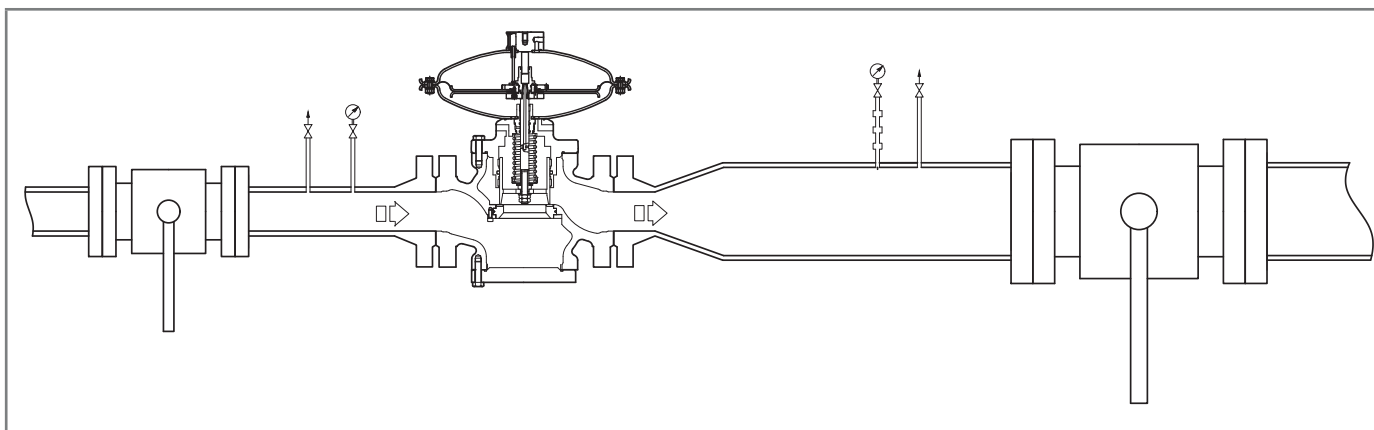

Fig. 6.27. Standard position

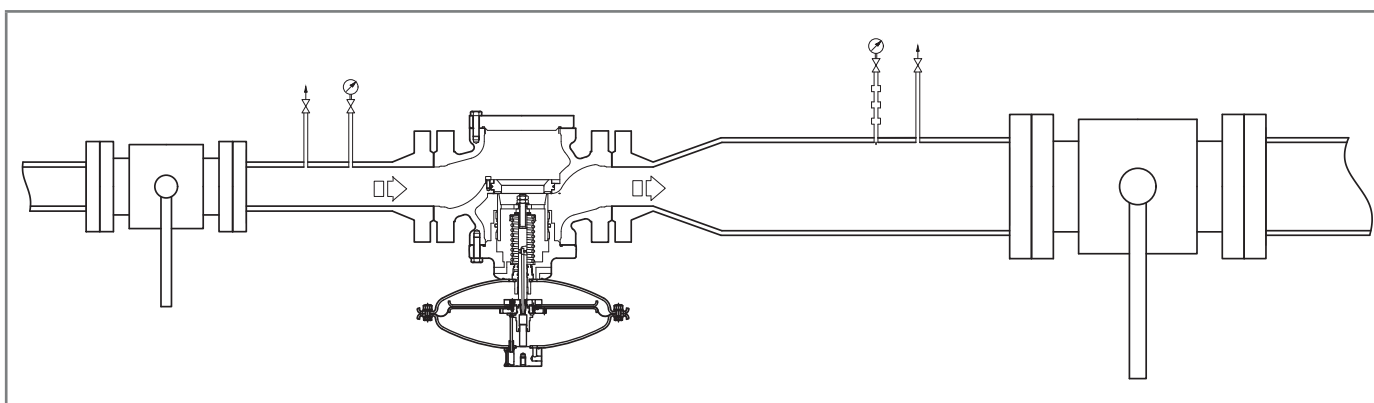

Fig. 6.28. Inverted position

6.5 - INSTALLATION PROCEDURE

6.5.1 - EQUIPMENT INSTALLATION PROCEDURES

Step	Action
1	Place the equipment in the section of the line designated for it.
2	Place the gaskets between the line flanges and the regulator flanges.
3	Insert the bolts into the appropriate holes of the connecting flanges.
4	Screw the bolts following the technical rules for tightening flanges.

Tab. 6.60.

NOTICE!

For installation after maintenance, replace the seals.

6.5.2 - CONNECTION OF THE SENSING LINES TO THE DOWNSTREAM PIPING

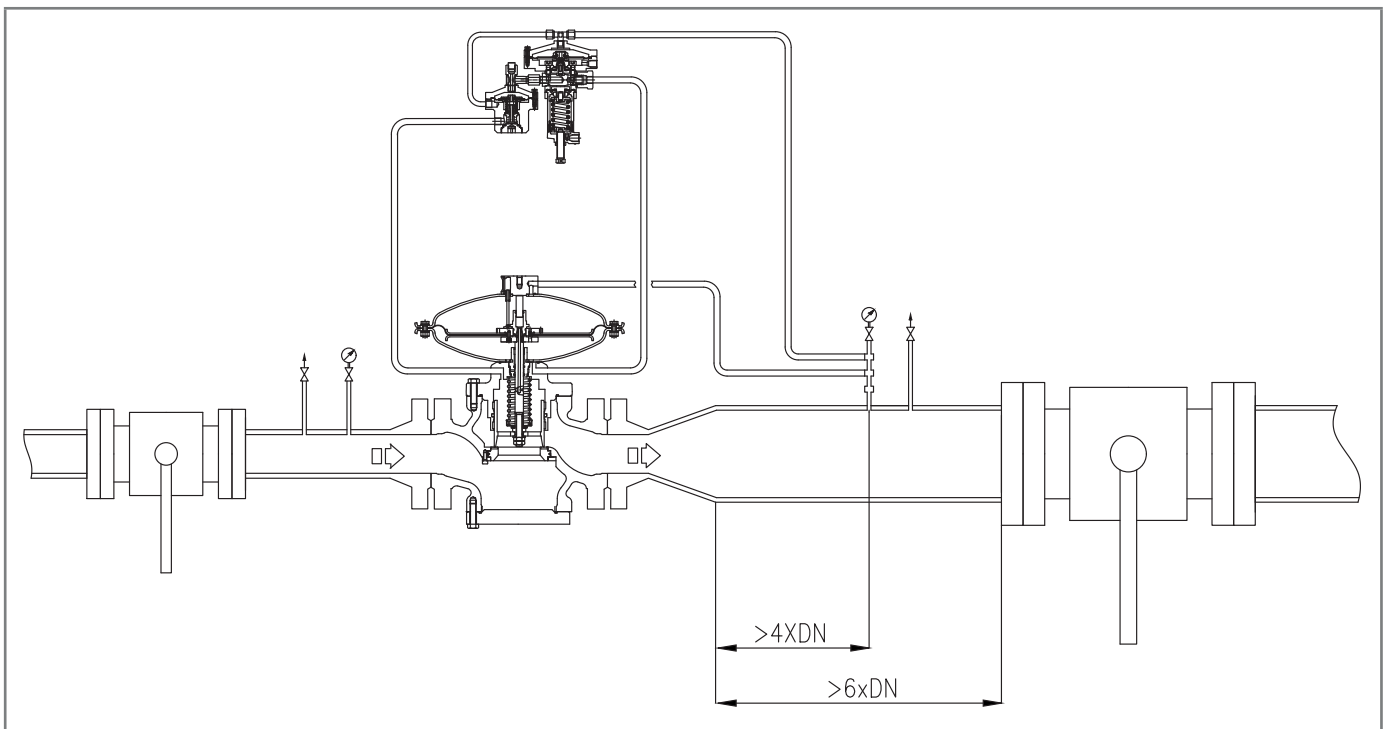

Fig. 6.29. Connection of sensing lines to the downstream piping

For proper adjustment, it is essential that:

- the downstream shut-off valve is placed at a distance of at least 6 times the nominal diameter of the pipe downstream of the regulator;
- the downstream sensing lines are placed on a straight section of pipe (with uniform diameter) having a length equal to at least 4 times the rated diameter of the pipe itself;

ATTENTION!

The pilot drain must not be connected to the multi-socket switch.

For optimum performance, the velocity of the pressurised fluid at the intake point should not exceed the following values:

$V_{max} = 30 \text{ m/s}$ for $P_a > 5 \text{ bar}$

$V_{max} = 25 \text{ m/s}$ for $P_a < 5 \text{ bar}$

As a limitation of use, the velocity of the pressurised fluid at the intake point does not exceed the following values:

$V_{max} = 40 \text{ m/s}$ for $P_a > 5 \text{ bar}$

To calculate the flow rate, use the following formula:

$$V = 345,92 \times \frac{Q}{DN^2} \times \frac{1 - 0,002 \times Pd}{1 + Pd}$$

V = gas velocity in m/sec

Q = gas flow rate in Sm³/h

DN = nominal diameter of the regulator in mm

Pd = regulator outlet pressure in barg

! NOTICE!

All on-site pneumatic connections must have pipes with a minimum internal diameter of 8 mm.

To prevent the pneumatic connections of the sensing lines from collecting impurities and condensation, it is necessary that:

- the pneumatic connection fittings are always welded to the top or horizontal axis of the pipe itself (refer to Fig. 6.30);
- the hole in the piping has no burrs or internal protrusions;
- the slope of the pneumatic connection is always 5-10% towards the downstream pipe fitting.

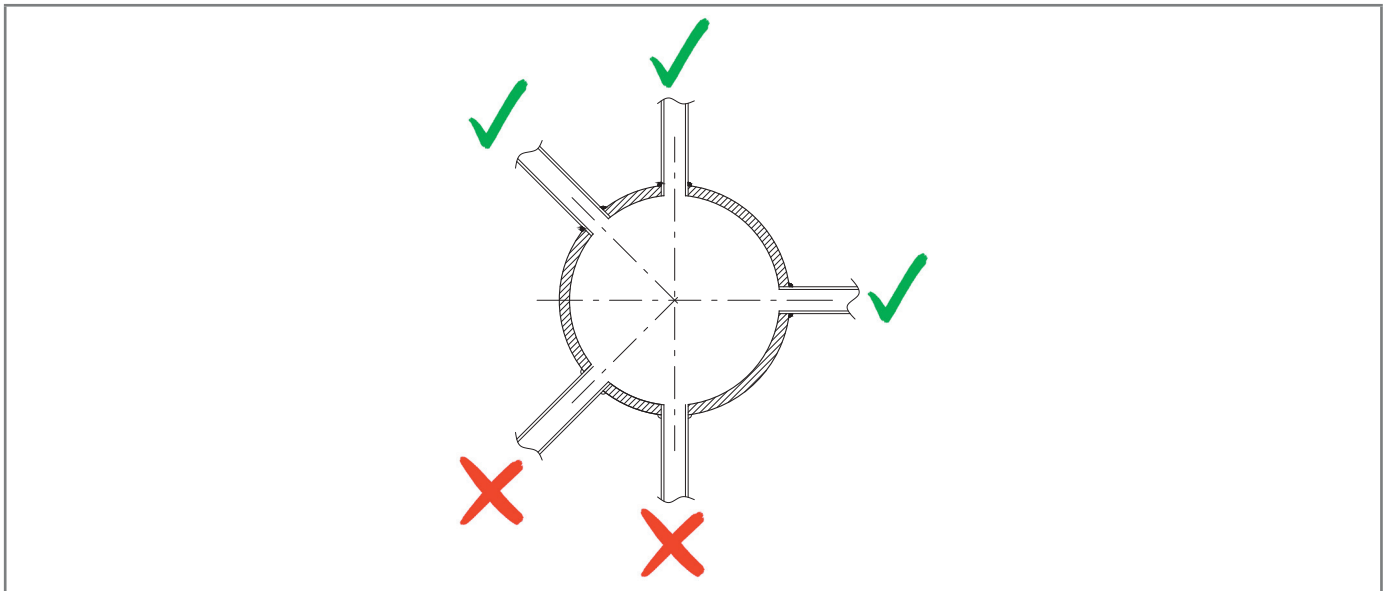

Fig. 6.30. *Welded pipe connections*

If there is a multiple sensing line, connect the equipment connections as shown below:

- 1 and 2 to the exhaust outlet of the regulator head and monitor PM/182 when present;
- 3 and 4 to the pilot sensing lines;
- 5 and 6 to the sensing lines of the slam-shut valve throttle if any.

! NOTICE!

**If there is a multiple sensing line, it is not recommended to place shut-off valves on sensing lines.
In any case, follow the regulations in force in the place of installation and use of the equipment.**

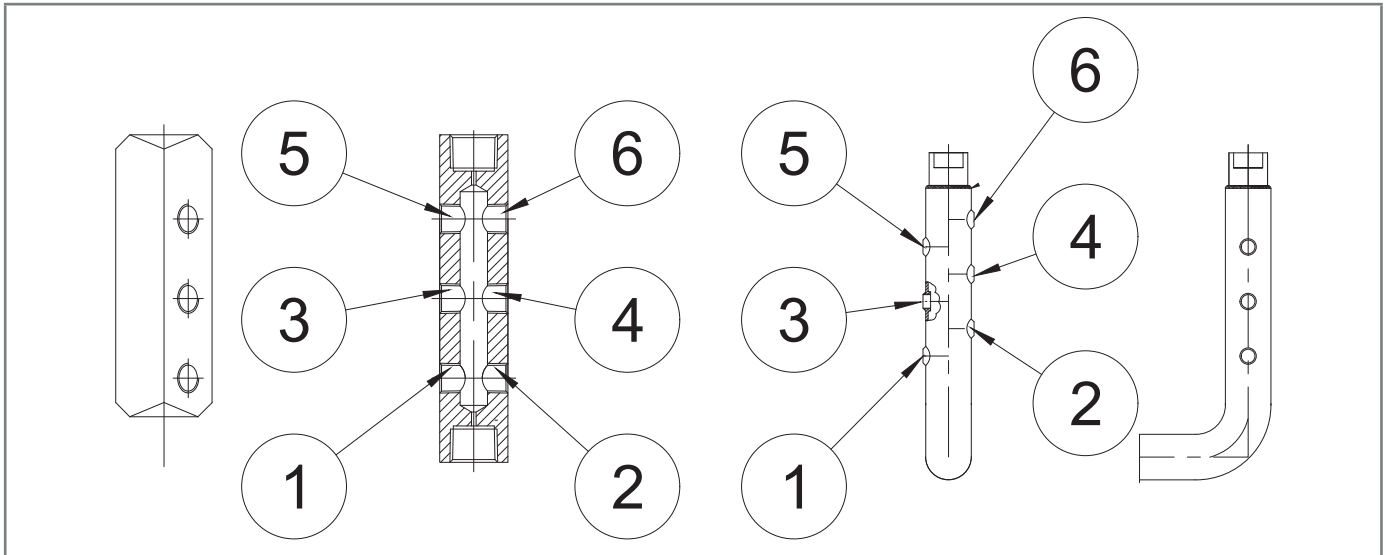

Fig. 6.31. Equipment connections

6.6 - POST-INSTALLATION AND PRE-COMMISSIONING CHECKS

When the equipment is operating, make sure that all connections are:

- properly secured/tightened to prevent any leakage during commissioning;
- connected correctly.







7 - COMMISSIONING/MAINTENANCE EQUIPMENT





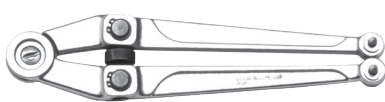

7.1 - LIST OF EQUIPMENT

Use of commissioning/maintenance equipment	
Operator qualification	<ul style="list-style-type: none"> • Mechanical maintenance technician; • Electrical maintenance technician; • Installer; • User technician.
PPE required	<div style="display: flex; align-items: center;">  </div> <div style="background-color: #f4a460; padding: 5px; margin-top: 5px;"> <p>⚠ WARNING!</p> </div> <p>The PPE listed in this table is related to the risk associated with the equipment. For the required PPE to protect against risks associated with the workplace, installation or operating conditions, please refer to:</p> <ul style="list-style-type: none"> • the regulations in force in the country of installation; • any information provided by the Safety Manager at the installation facility.

Tab. 7.61.

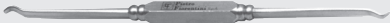
The types of equipment required to commission and service the equipment are described in Tab. 7.62:

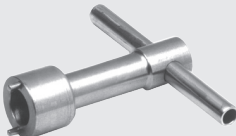
Ref.	Equipment type	Image
A	Combination wrench	
B	Adjustable wrench	
C	Compass wrench	
D	Double ended bi-hex tubular socket wrench	
E	Bent male hex wrench	
F	Male hex T-key	

Ref.	Equipment type	Image
G	T-handle hexagon socket spanner	
H	Phillips screwdriver	
I	Slotted screwdriver	
L	O-ring extraction tool	
M	Circlip pliers	
N	Fiorentini special key	
O	Fiorentini special key	
P	Fiorentini special tool	

Tab. 7.62.

7.2 - EQUIPMENT NEEDED FOR THE DIFFERENT CONFIGURATIONS

Each table is distinguished by:

Term	Description
K./Wr.	Key, with reference to the equipment indicated in Tab. 7.62.
Code	Code, referring to the equipment.
DN	Indicates the Nominal Diameter of the reference configuration.
L.	Length, referring to the equipment.
Ref.	Reference to the equipment.
Type	Type (size) or code of the equipment.

Tab. 7.63.

NOTICE!

Equipment for DB/182 silencer configurations (see paragraph 5.2) refer to the REVAL 182 + DB/182 equipment table (Tab. 7.65). If necessary, please refer to the accessories equipment table.

REVAL 182 (+LDB/171)									
Equipment		Size [inches]							
Ref.	Type	1"	2"	2" 1/2	3"	4"	6"	8"	10"
A	K./Wr.	10-16-17- 18-19-22- 27-30	10-16-17- 18-19-22- 24-27-30	10-16-17- 18-19-22- 24-27-30	10-16-17- 18-19-22- 24-27-30	10-16-17- 18-19-22- 24-27-41	10-16-17- 18-19-22- 24-27-41	10-16-1- 18-19-22- 27-41	10-16-17- 18-19-24- 30-55
B	L.	300							
C	Ø	4							
D	K./Wr.	-	-	-	-	-	27-41	27-41	30-55
E	K./Wr.	2.5-8	2.5-8	2.5-8	2.5-8	2.5-8	2.5-8	2.5-8	2.5-8
F	K./Wr.	4-5-8	4-5-8	4-5-8	4-5-8	4-5-8	4-5-8	4-5-8	4-5-8
G	K./Wr.	8-10-17- 20	8-10-17- 20		10-17-19- 22	10-17-19- 22	10-17	10-17	10-17
I	L.	65x100							
L	Code	7999099							

Tab. 7.64.

REVAL 182 + DB/182										
Equipment		Size [inches]								
Ref.	Type	1"	2"	2" 1/2	3"	4"	6"	8"	10"	
A	K./Wr.	10-16-17- 18-19-22- 24-27-30	10-16-17- 18-19-22- 24-27-30	10-16-17- 18-19-22- 24-27-30	10-16-17- 18-19-22- 24-27-30	10-16-17- 18-19-22- 24-27-41	10-16-17- 18-19-22- 24-27-41	10-16-17- 18-19-22- 24-27-41	10-16-17- 18-19-22- 24-27-41	10-16-17- 18-19-24- 30-32-55
B	L.	300								
C	Ø	4								
D	K./Wr.						27-41	27-41	30-55	
E	K./Wr.	2.5-8	2.5-8	2.5-8	2.5-8	2.5-8	2.5-8	2.5-8	2.5-8-14	
F	K./Wr.	4-5-8	4-5-8	4-5-8	4-5-8	4-5-8	4-5-8	4-5-8	4-5-8	
G	K./Wr.	8-10- 17-20	8-10- 17-20	10-17-19- 20	10-17-19- 20	10-17-19- 20	10-17	10-17	10-17	
I	L.	65x100								
L	Code	7999099								
O	Code	7999031	7999033	7999034	7999035	7999036	7999037	7999038	7999041	

Tab. 7.65.

REVAL 182 + PM/182									
Equipment		Size [inches]							
Ref.	Type	1"	2"	2" 1/2	3"	4"	6"	8"	
A	K./Wr.	10-16-17- 18-19-22- 27-30	10-16-17- 18-19-22- 24-27-30	10-16-17- 18-19-22- 24-27-30	10-16-17- 18-19-22- 24-27-30	10-16-17- 18-19-22- 24-27-41	10-16-17- 18-19-22- 24-27-41	10-16-17- 18-19-22- 24-27-41	10-16-17- 18-19-22- 24-27-41
B	L.	300							
C	Ø	4							
D	K./Wr.	-	-	-	-	-	27-41	27-41	
E	K./Wr.	2.5-8	2.5-8	2.5-8	2.5-8	2.5-8	2.5-8	2.5-8	2.5-8
F	K./Wr.	4-5-8	4-5-8	4-5-8	4-5-8	4-5-8	4-5-8	4-5-8	4-5-8
G	K./Wr.	8-10-17-20	8-10-17-20	8-10-19-22	8-10-19-22	8-10-19-22	10-17	10-17	
I	L.	65x100							
L	Code	7999099							

Tab. 7.66.

REVAL 182 + SA						
Equipment		Size [inches]				
Ref.	Type	1"	2"	2" 1/2	3"	4"
B	L.	300				
C	Ø	4				
D	K./Wr.	24	24	24	24	24
E	K./Wr.	2.5-8	2.5-8	2.5-8	2.5-8	2.5-8
F	K./Wr.	4-5-8	4-5-8	4-5-8	4-5-8	4-5-8
I	L.	65x100				
L	Code	7999099				

Tab. 7.67.

REVAL 182 + SB/82										
Equipment		Size [inches]								
Ref.	Type	1"	2"	2" 1/2	3"	4"	6"	8"	10"	
A	K./Wr.	10-16-17- 18-19-22- 24-27-30	10-16-17- 18-19-22- 24-27-30	10-16-17- 18-19-22- 24-27-30	10-16-17- 18-19-22- 24-27-30	10-16-17- 18-19-22- 24-27-41	10-16-17- 18-19-22- 24-27-41	10-16-17- 18-19-22- 24-27-41	10-16-17- 18-19-22- 24-27-41	10-16-17- 18-19-24- 30-55
B	L.	300								
C	Ø	4								
D	K./Wr.	24	24	24	24	24	24-27-41	24-27-41	27-30-55	
E	K./Wr.	2.5-8	2.5-8	2.5-8	2.5-8	2.5-8	2.5-8	2.5-8	2.5-8-14	
F	K./Wr.	4-5-8	4-5-8	4-5-8	4-5-8	4-5-8	4-5-8	4-5-8	4-5-8	
G	K./Wr.	8-10-17- 20	8-10-17- 20	8-10-19- 22	8-10-19- 22	8-10-19- 22	10-17	10-17	10-17	
I	L.	65x100								
L	Code	7999099								
M	Ø	19-60								
N	Code	7999019								

Tab. 7.68.

REVAL 182 + HB/97					
Equipment		Size [inches]			
Ref.	Type	4"	6"	8"	10"
A	K./Wr.	10-16-17-18-19-22- 24-27-41	10-16-17-18-19-22- 24-27-41	10-16-17-18-19-22- 24-27-41	7-10-16-17-19-24-30- 55-57
B	L.	300			
C	Ø	4			
D	K./Wr.	24	24-27-41	24-27-41	17-27-30-55
E	K./Wr.	2.5-8	2.5-8	2.5-8	4-5-8
F	K./Wr.	4-5-8	4-5-8	4-5-8	10-17
I	L.	6.5 x 100			
L	Code	7999099			
M	Ø	19÷60			
N	Code	7999019			
P	Code	7999097			

Tab. 7.69.

8 - COMMISSIONING

8.1 - GENERAL WARNINGS

8.1.1 - SAFETY REQUIREMENTS FOR COMMISSIONING

HAZARD!

During commissioning the risks associated with any discharges to the atmosphere of flammable or noxious gases must be evaluated.

HAZARD!

In case of installation on distribution networks for natural gas, consider the risk associated with explosive mixtures (gas/air) being formed inside the piping, if the line is not subjected to inerting.

WARNING!

During commissioning, any unauthorised personnel must keep away. The 'no entry' area has to be marked with signs and/or boundaries.

NOTICE!

Commissioning has to be carried out by authorised and qualified personnel.

The equipment is supplied with the pilot unit already calibrated.

Even if the built-in monitor PM/182, or the built-in slam-shut valves SA, SB/82 or HB/97 are fitted to the equipment, any pilots or pressure switches installed will already be calibrated.







NOTICE!

It is possible that for various reasons (e.g. vibrations during transport) the calibration of the equipment's accessories may vary, although within the values indicated on the identification plates.

Before commissioning the equipment, it is necessary to check that:

- all shut-off valves (inlet, outlet, any bypass) are closed;
- the gas is at a temperature within the limits specified on the data plate.

Commissioning

Operator qualification	<ul style="list-style-type: none"> • Installer; • Qualified technician.
PPE required	<div style="display: flex; align-items: center;">      </div> <p> WARNING!</p> <p>The PPE listed in this table is related to the risk associated with the equipment. For the required PPE to protect against risks associated with the workplace, installation or operating conditions, please refer to:</p> <ul style="list-style-type: none"> • the regulations in force in the country of installation; • <u>any information provided by the Safety Manager at the installation facility.</u>
Equipment required	Please refer to the chapter "7 - Commissioning/maintenance equipment".

Tab. 8.70.

8.2 - PRELIMINARY PROCEDURES FOR COMMISSIONING

HAZARD!

Before commissioning the equipment, it must be ensured that any source of explosion has been eliminated if there is such a danger.

WARNING!

Before commissioning, you need to make sure that the characteristics of the equipment are suitable for the conditions of use.

ATTENTION!

To protect the equipment from damage, the following operations must never be carried out:

- pressurisation through a valve located downstream of the equipment;
- depressurise the equipment through a valve located upstream of it.

Commissioning can be carried out using two different procedures:

Commissioning types

Injection of an inert fluid	Pressurising the equipment by injecting an inert fluid (e.g. nitrogen) to avoid potentially explosive mixtures for services with combustible gases. <div style="background-color: #f4a460; padding: 5px; margin-top: 5px;">  WARNING! During pressurisation, always check that the equipment has no leaks. </div>
Direct injection	Direct injection of gas into pipes, keeping the gas velocity in the pipes as low as possible (maximum permitted value of 5 m/s).

Tab. 8.71.

8.3 - PROPER COMMISSIONING CHECK

Thoroughly spray the equipment with a foam solution to check the tightness of the external surfaces of the regulator and the connections made during installation (or equivalent control system).

8.4 - CALIBRATION OF EQUIPMENT AND ACCESSORIES INSTALLED

 **NOTICE!**

To properly calibrate the equipment and accessories present, refer to the accuracy class indicated on the rating plates (see paragraph 2.8).

8.5 - REGULATOR COMMISSIONING PROCEDURE

In the application consisting of multiple pressure adjusting lines, it is advisable to commission one line at a time, starting with the line with the lowest set point.

The set point value is mentioned on the test certificate enclosed with each piece of equipment.

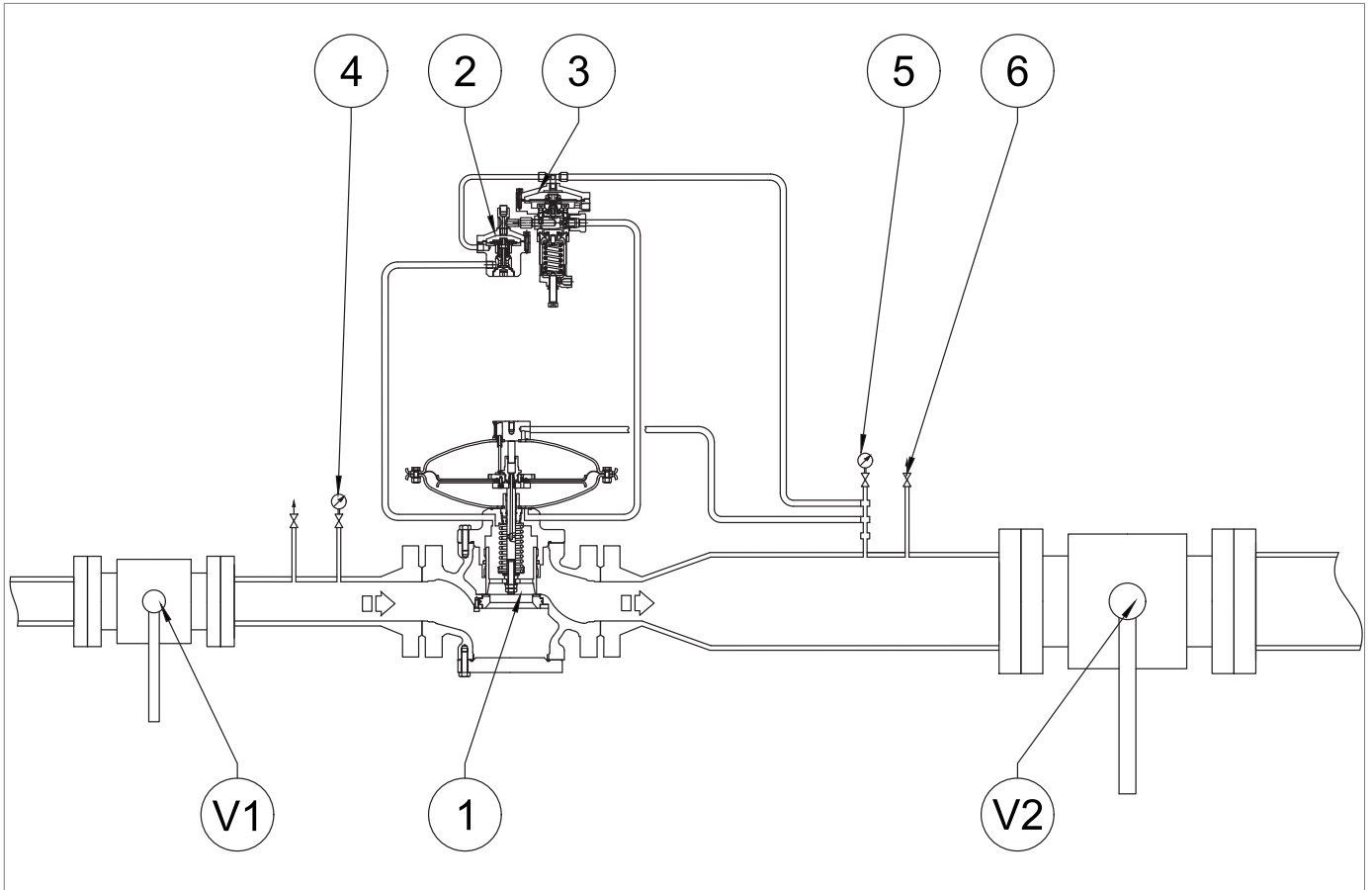

Fig. 8.32. Commissioning the regulator REVAL 182

Step	Action
1	Partially open the bleed cock (6).
2	Completely unscrew the fixing nut and adjusting screw (Fig. 8.43) of the pilot (3) to relieve the spring.
3	Open the inlet shut-off valve (V1) very slowly. ! NOTICE! Check the pressure by referring to the pressure gauge (4) located upstream.
4	Turn the pilot adjustment screw (3) clockwise to load the calibration spring until the regulator (1) trips. ! NOTICE! Check the pressure referring to the pressure gauge (5) located upstream.
5	Close the bleed cock (6).
6	Check that the downstream pressure, after an increase phase, does not exceed the shut-off pressure value (refer to the SG value on the nameplate, see par. 2.8). ! NOTICE! If the downstream pressure exceeds the closing pressure value, refer to chapter "10 - Troubleshooting" to clear the causes of the malfunctions.
7	Check the tightness of all the fittings between the shut-off valves (V1, V2). ! NOTICE! Check for sealing with a foaming substance.
8	Open the downstream shut-off valve (V2) very slowly until the piping has been filled completely. ! NOTICE! If at the beginning of this operation, the pressure in the downstream pipeline is much lower than the calibration pressure, split the opening of this valve so as not to exceed the maximum flow rate of the system.
9	Tighten the adjusting screw and fixing nut (Fig. 8.43) of the pilot (3).

Tab. 8.72.

8.6 - COMMISSIONING PROCEDURE FOR THE REVAL 182 REGULATOR WITH BUILT-IN MONITOR PM/182

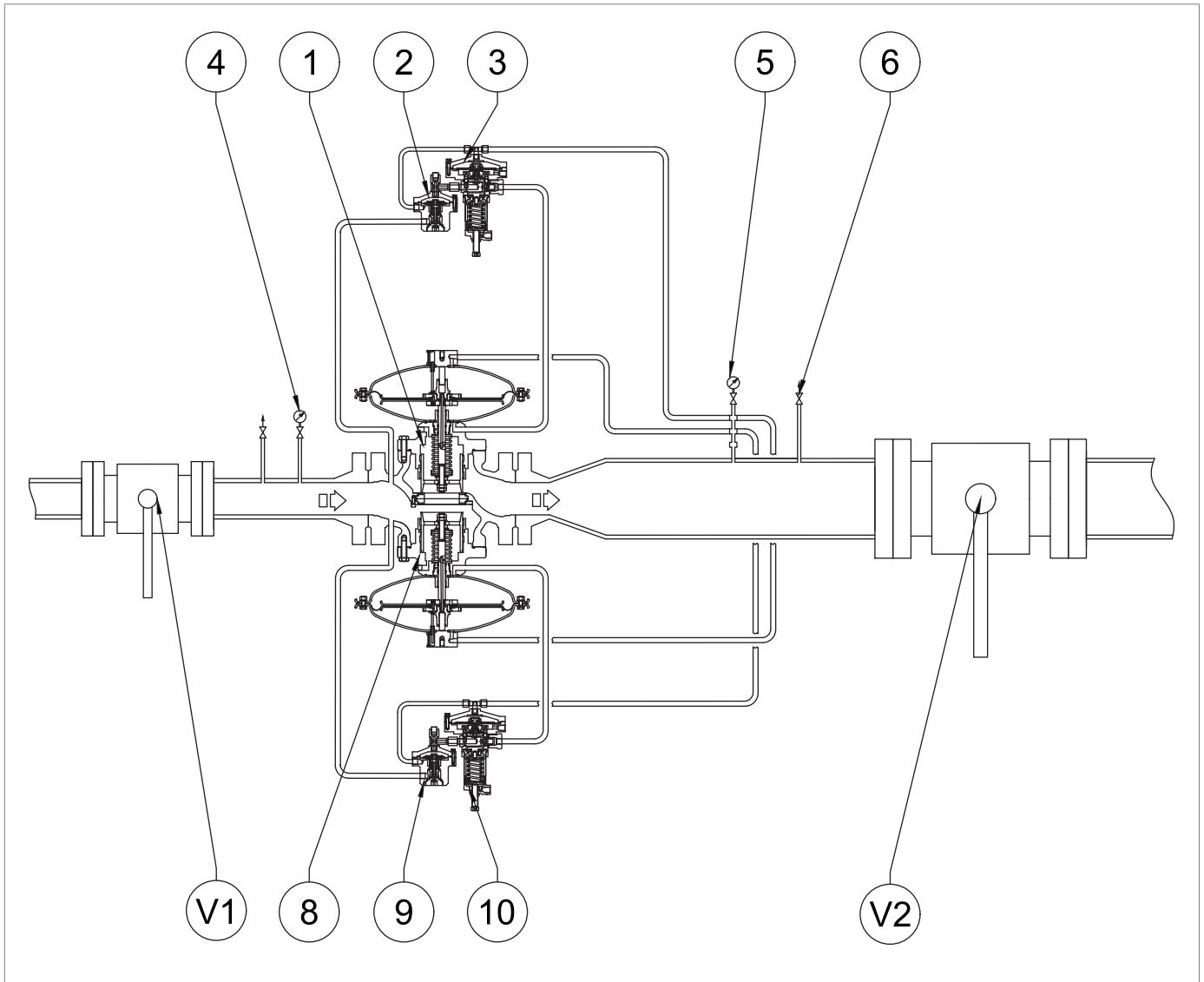

Fig. 8.33. Procedure for commissioning the regulator REVAL 182 with PM/182 built-in monitor

Step	Action
1	Partially open the bleed cock (6).
2	Completely unscrew the nut securing the adjusting screws (Fig. 8.43) of the pilots (3, 10).
3	Completely compress the pilot spring (3) by turning the adjusting screw (Fig. 8.43) clockwise.
4	Completely relieve the pilot spring (10) by turning the adjusting screw (Fig. 8.43) anti-clockwise.
5	Open the inlet shut-off valve (V1) very slowly. <div style="border: 1px solid black; padding: 5px; margin-top: 5px;"> <p>! NOTICE! Check the pressure by referring to the pressure gauge (4) located upstream.</p> </div>
6	Turn the adjustment screw (Fig. 8.43) on the monitor pilot (10) clockwise to increase the downstream pressure value to the selected monitor operating value. <div style="border: 1px solid black; padding: 5px; margin-top: 5px;"> <p>! NOTICE! Check the pressure referring to the pressure gauge (5) located upstream.</p> </div>

Step	Action
7	Turn the adjusting screw (Fig. 8.43) on the pilot (3) anti-clockwise to relieve the calibration spring until the regulator trips.
8	Make sure that the PM/182 monitor (8) is fully open (100%) by checking the position of the stroke indicator rod (Fig. 4.6).
9	<p>Check that the calibration pressure is at the set value by referring to the downstream pressure gauge (5).</p> <div style="border: 1px solid black; padding: 5px;"> <p>! NOTICE!</p> <ul style="list-style-type: none"> • To reduce the pressure (to the required value): turn the pilot adjustment screw (3) anti-clockwise; • To increase the pressure (to the required value): turn the pilot adjustment screw (3) clockwise. </div>
10	Slowly close the bleed cock (6).
11	<p>Check that the downstream pressure, after an increase phase, does not exceed the shut-off pressure value (refer to the SG value on the nameplate, see par. 2.8).</p> <div style="border: 1px solid black; padding: 5px;"> <p>! NOTICE!</p> <ul style="list-style-type: none"> • If the downstream pressure exceeds the closing pressure value, refer to chapter “10 - Troubleshooting” to clear the causes of the malfunctions. • Check the pressure referring to the pressure gauge (5) located upstream. </div>
12	<p>Check all joints between the shut-off valves (V1, V2) for sealing.</p> <div style="border: 1px solid black; padding: 5px;"> <p>! NOTICE!</p> <p>Check for sealing with a foaming substance.</p> </div>
13	<p>Open the downstream shut-off valve (V2) very slowly until the pipeline fills completely.</p> <div style="border: 1px solid black; padding: 5px;"> <p>! NOTICE!</p> <ul style="list-style-type: none"> • If at the beginning of this operation the pressure in the pipeline is much lower than the calibration pressure, it will be advisable to partially open this valve so as not to exceed the maximum flow rate of the system. • Check the pressure referring to the pressure gauge (5) located upstream. </div>
14	Tighten the adjusting screws and pilot nuts (Fig. 8.43) (3, 11).

Tab. 8.73.

8.7 - COMMISSIONING PROCEDURE FOR THE REVAL 182 REGULATOR WITH BUILT-IN PM/182 MONITOR AND V/25 ACCELERATING VALVE

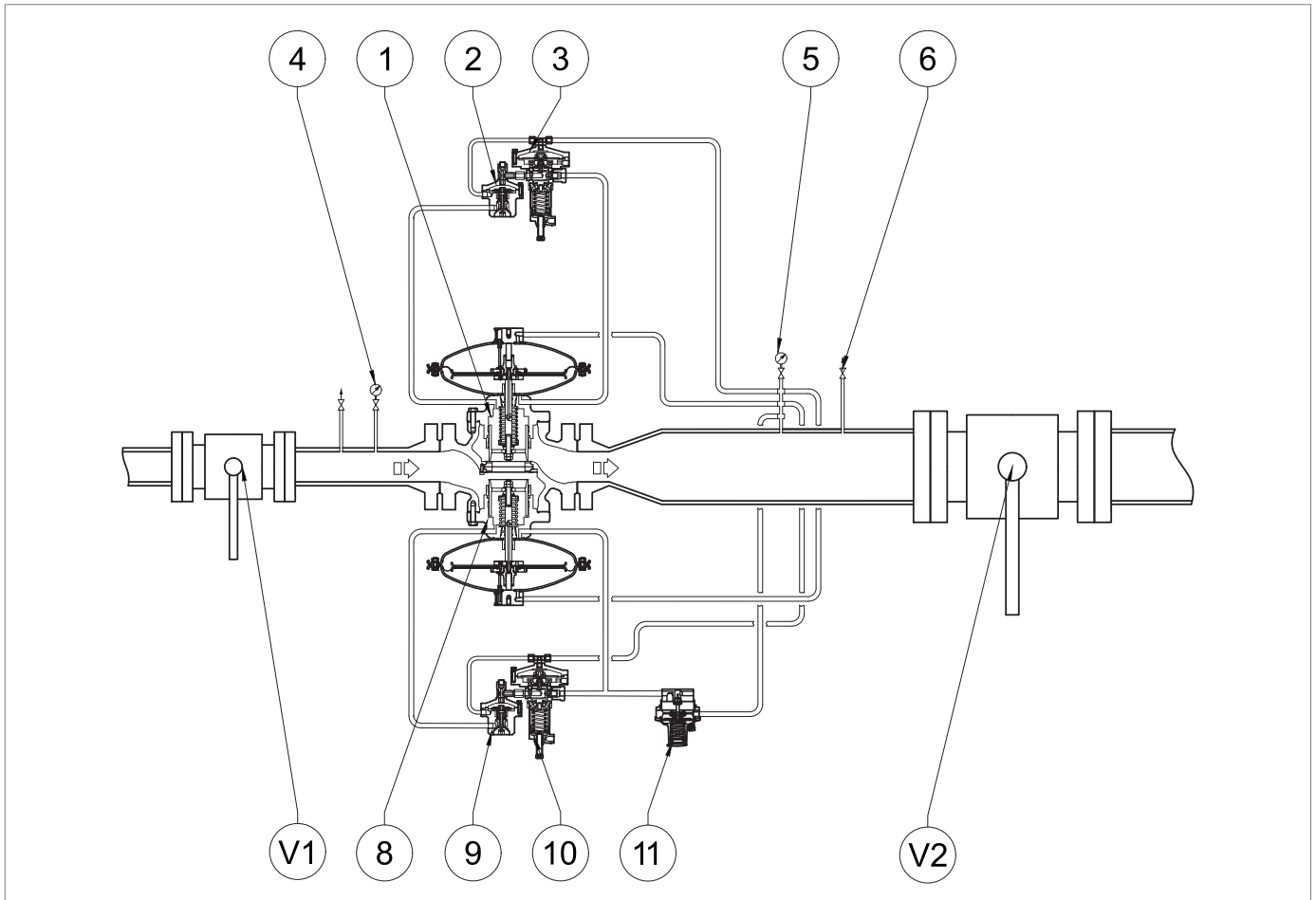

Fig. 8.34. Commissioning of the REVAL 182 regulator with built-in monitor PM/182 and V/25 accelerating valve

Step	Action
1	Partially open the bleed cock (6).
2	Completely unscrew the fixing nut of the pilot adjustment screw (3, 10).
3	Completely compress the pilot spring (3) by turning the adjusting screw (Fig. 8.43) clockwise.
4	Completely relieve the pilot spring (10) by turning the adjusting screw (Fig. 8.43) anti-clockwise.
5	Completely compress the spring of the V/25 throttle valve (11) by turning the adjustment ring nut clockwise (Fig. 8.43).
	Open the inlet shut-off valve (V1) very slowly.
6	<div style="border: 1px solid blue; padding: 5px;"> <p>! NOTICE!</p> <p>Check the pressure by referring to the pressure gauge (4) located upstream.</p> </div>
	Slowly increase the downstream pressure by turning the adjusting screw (Fig. 8.43) of the monitor pilot (10) clockwise until the setpoint pressure of the V/25 throttle valve (11) is reached.
7	<div style="border: 1px solid blue; padding: 5px;"> <p>! NOTICE!</p> <p>Check the pressure referring to the pressure gauge (5) located upstream.</p> </div>

Step	Action
8	<p>Turn the adjusting ring (Fig. 8.43) of the V/25 throttle valve (11) anti-clockwise to decrease the setting of the tripping pressure value until gas is escapes from the gas outlet.</p> <p>NOTICE!</p> <p>Check for sealing with a foaming substance.</p>
9	<p>Turn the adjusting screw (Fig. 8.43) on the monitor pilot (10) anti-clockwise to decrease the downstream pressure value to the selected monitor operating value.</p> <p>NOTICE!</p> <ul style="list-style-type: none"> • Ensure that the throttle valve (12) has cut off the gas discharge; • Check the pressure referring to the pressure gauge (5) located upstream.
10	<p>Turn the adjusting screw (Fig. 8.43) on the pilot (3) anti-clockwise to relieve the calibration spring until the regulator trips.</p> <p>NOTICE!</p> <p>Check the pressure referring to the pressure gauge (5) located upstream.</p>
11	<p>Make sure that the PM/182 monitor (8) is fully open (100%) by checking the position of the stroke indicator rod (Fig. 4.6).</p>
12	<p>Check that the calibration pressure is at the set value by referring to the downstream pressure gauge (5).</p> <p>NOTICE!</p> <ul style="list-style-type: none"> • To reduce the pressure (down to the pre-set value): turn the pilot adjustment screw (3) anti-clockwise; • To increase the pressure (up to the pre-set value): turn the pilot adjustment screw (3) clockwise.
13	<p>Slowly close the bleed cock (6).</p>
14	<p>Check that the downstream pressure, after an increase phase, does not exceed the shut-off pressure value (refer to the SG value on the nameplate, see par. 2.8).</p> <p>NOTICE!</p> <ul style="list-style-type: none"> • If the downstream pressure exceeds the closing pressure value, refer to chapter “10 - Troubleshooting” to clear the causes of the malfunctions; • Check the pressure referring to the pressure gauge (5) located upstream.
15	<p>Check all joints between the shut-off valves (V1, V2) for sealing.</p> <p>NOTICE!</p> <p>Check for sealing with a foaming substance.</p>
16	<p>Open the downstream shut-off valve (V2) very slowly until the piping has been filled completely.</p> <p>NOTICE!</p> <ul style="list-style-type: none"> • If at the beginning of this operation, the pressure in the downstream pipeline is much lower than the calibration pressure, split the opening of this valve so as not to exceed the maximum flow rate of the system. • Check the pressure referring to the pressure gauge located upstream.
17	<p>Tighten the adjusting screws (Fig. 8.43) and pilot nuts (3, 10).</p>

Tab. 8.74.

8.8 - COMMISSIONING PROCEDURE FOR THE REVAL 182 REGULATOR WITH BUILT-IN PM/182 MONITOR AND M/A ACCELERATING VALVE

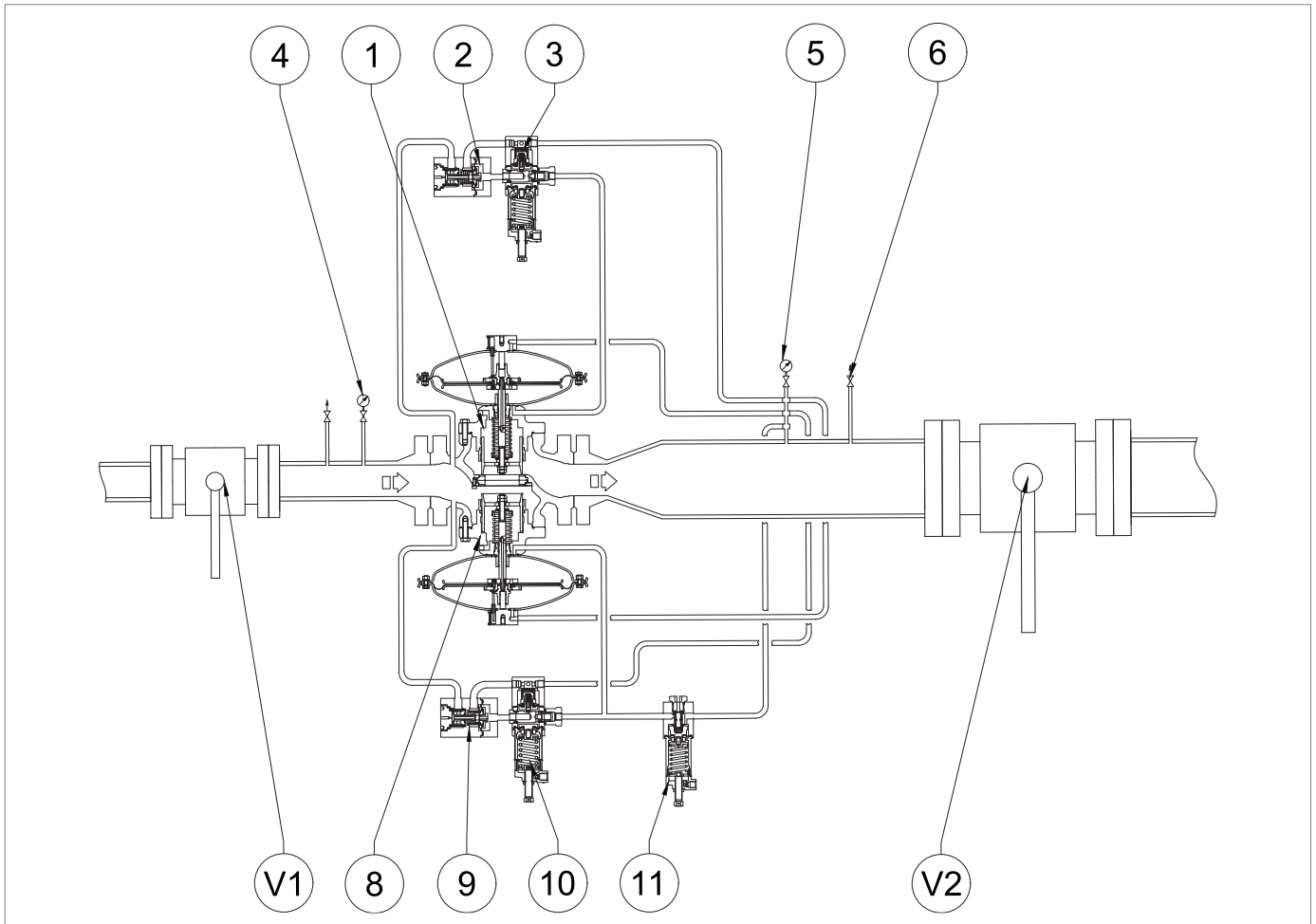

Fig. 8.35. Commissioning of the REVAL 182 regulator with built-in PM/182 monitor and M/A accelerating valve

Step	Action
1	Partially open the bleed cock (6).
2	Completely unscrew the fixing nut of the pilot adjustment screw (3, 10) and the M/A accelerating valve (11).
3	Completely compress the pilot spring (3) by turning the adjusting screw (Fig. 8.43) clockwise.
4	Completely relieve the pilot spring (10) by turning the adjusting screw (Fig. 8.43) anti-clockwise.
5	Fully compress the M/A accelerating valve spring (11) by turning the adjusting screw clockwise.
6	Open the inlet shut-off valve (V1) very slowly. <div style="border: 1px solid black; padding: 5px; margin-top: 5px;"> <p>! NOTICE! Check the pressure by referring to the pressure gauge (4) located upstream.</p> </div>
7	Slowly increase the downstream pressure by turning the adjustment screw (Fig. 8.43) of the monitor pilot (10) clockwise until the intervention pressure value of the M/A throttle valve (11) is reached. <div style="border: 1px solid black; padding: 5px; margin-top: 5px;"> <p>! NOTICE! Check the pressure referring to the pressure gauge (5) located upstream.</p> </div>

Step	Action
8	<p>Turn the adjusting screw of the M/A accelerating valve (11) anti-clockwise to decrease the calibration of the cut-in pressure value until gas is released from the gas outlet.</p> <p>NOTICE!</p> <p>Check for sealing with a foaming substance.</p>
9	<p>Turn the adjusting screw (Fig. 8.43) on the monitor pilot (10) anti-clockwise to decrease the downstream pressure value to the selected monitor operating value.</p> <p>NOTICE!</p> <ul style="list-style-type: none"> • Ensure that the accelerating valve (11) has cut off the gas discharge; • Check the pressure referring to the pressure gauge (5) located upstream.
10	<p>Turn the adjusting screw (Fig. 8.43) on the pilot (3) anti-clockwise to relieve the calibration spring until the regulator trips.</p> <p>NOTICE!</p> <p>Check the pressure referring to the pressure gauge (5) located upstream.</p>
11	<p>Make sure that the PM/182 monitor (8) is fully open (100%) by checking the position of the stroke indicator rod (Fig. 4.6).</p>
12	<p>Check that the calibration pressure is at the set value by referring to the downstream pressure gauge (5).</p> <p>NOTICE!</p> <ul style="list-style-type: none"> • To reduce the pressure (down to the pre-set value): turn the pilot adjustment screw (3) anti-clockwise; • To increase the pressure (up to the pre-set value): turn the pilot adjustment screw (3) clockwise.
13	<p>Slowly close the bleed cock (6).</p>
14	<p>Check that the downstream pressure, after an increase phase, does not exceed the shut-off pressure value (refer to the SG value on the nameplate, see par. 2.8).</p> <p>NOTICE!</p> <ul style="list-style-type: none"> • If the downstream pressure exceeds the closing pressure value, refer to chapter “10 - Troubleshooting” to clear the causes of the malfunctions; • Check the pressure on the pressure gauge (5) located upstream
15	<p>Check all joints between the shut-off valves (V1, V2) for sealing.</p> <p>NOTICE!</p> <p>Check for sealing with a foaming substance.</p>
16	<p>Open the downstream shut-off valve (V2) very slowly until the pipeline fills completely.</p> <p>NOTICE!</p> <ul style="list-style-type: none"> • If at the beginning of this operation, the pressure in the downstream pipeline is much lower than the calibration pressure, split the opening of this valve so as not to exceed the maximum flow rate of the system. • Check the pressure referring to the pressure gauge (5) located upstream.
17	<p>Lock the adjustment screws (Fig. 8.43) and the fixing nuts of the pilots (3, 10) and of the M/A throttle valve (11).</p>

Tab. 8.75.

8.9 - CHECKING THE SA SLAM-SHUT VALVE FOR SEALING DURING SHUT-OFF

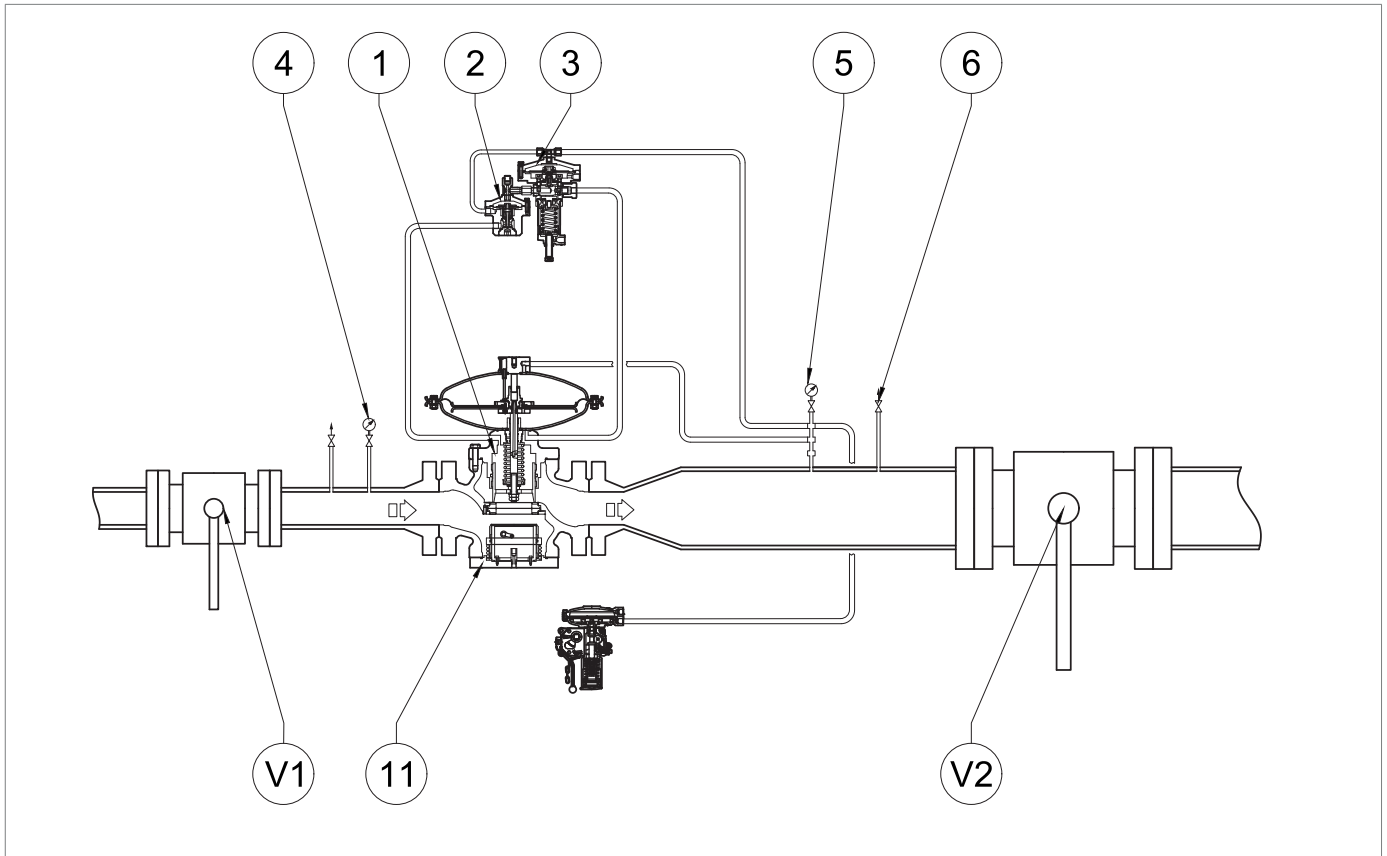

Fig. 8.36. Commissioning of the regulator REVAL 182 with SA slam-shut valve

Step	Action
1	Check that the slam-shut valve is in the shut-off position.
2	Open the drain cock (6) and drain the downstream section completely.
3	Slowly open upstream valve V1.
4	Check the tightness of the slam-shut valve through the pilot circuit supply connection located under the regulator head, disconnecting the connection from the regulator. <div style="border: 1px solid blue; padding: 5px; margin-top: 5px;"> <p>! NOTICE!</p> <ul style="list-style-type: none"> • Check the seal with a foaming substance; • In case of leaks from the connection, see chapter “10 - Troubleshooting” to remove the causes of the dysfunction. </div>
5	Reconnect the power connection of the drive circuit. <div style="border: 1px solid blue; padding: 5px; margin-top: 5px;"> <p>! NOTICE!</p> <p>If necessary, replace the fitting by referring to the fitting manufacturer's instructions.</p> </div>

Tab. 8.76.

PAGE INTENTIONALLY LEFT BLANK

8.9.1 - CALIBRATION PROCEDURE FOR PRESSURE SWITCHES MOD. SA

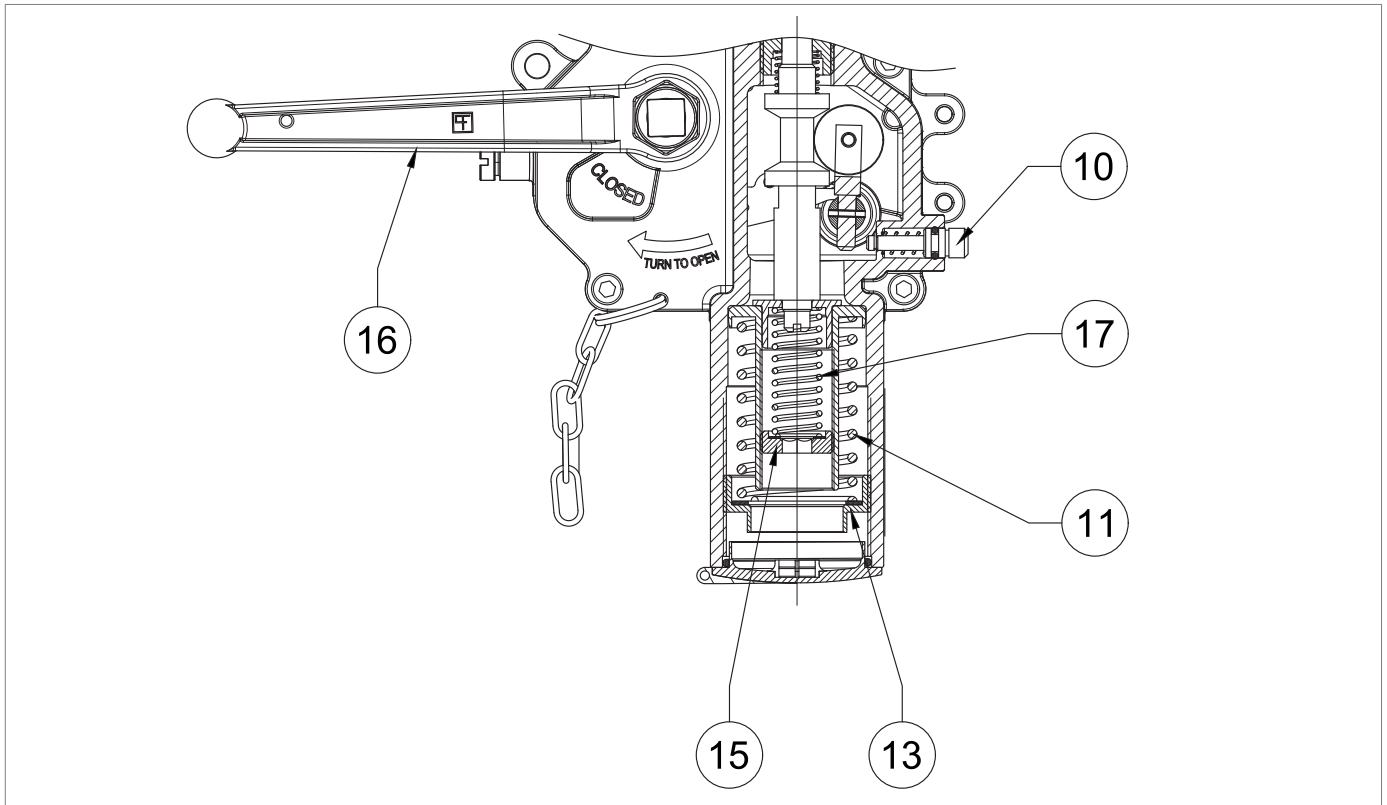

Fig. 8.37. Calibration of pressure switches mod. SA

SPRING SETTING FOR MAXIMUM PRESSURE TRIPPING

Step	Action
1	<p>Increase the downstream pressure to the slam-shut valve's cut-out value by turning the main regulator's pilot adjustment screw to check that the setting is correct.</p> <p>! NOTICE!</p> <p>Check the pressure referring to the pressure gauge (Fig. 8.32, ref.5) downstream of the main regulator.</p> <p>If the slam-shut valve:</p> <ul style="list-style-type: none"> • trips before the expected pressure value: screw in (clockwise) the adjustment ring nut (13) so as to further compress the spring (11); • does not trip at the expected pressure value: unscrew (anti-clockwise) the adjustment ring nut (13) so as to relieve the spring (11).
2	By opening the drain cock (Fig. 8.32, ref. 6), decrease the pressure in the downstream section to the calibration value of the main regulator.
3	Close the bleed cock (Fig. 8.32, ref.6).
4	Reset the slam-shut valve by acting on the reset lever (16).
5	<p>Repeat steps 2-3-4 at least three times.</p> <p>! NOTICE!</p> <p>The calibration value must comply with the operating limits specified on the plate.</p>

Tab. 8.77.

SPRING SETTING FOR MINIMUM PRESSURE TRIPPING (IF PRESENT)

Step	Action
1	Partially open the drain cock (Fig. 8.32, ref.6) to the atmosphere and keep it open for the next steps.
2	<p>Decrease the downstream pressure to the minimum required slam-shut device pressure by turning the main regulator's pilot adjustment screw.</p> <div style="border: 1px solid black; padding: 5px;"> <p>! NOTICE!</p> <p>Check the pressure referring to the downstream pressure gauge (Fig. 8.32, ref. 5).</p> <p>If the slam-shut valve:</p> <ul style="list-style-type: none"> • trips before the expected pressure value: unscrew (anti-clockwise) the adjustment ring nut (15) so as to relieve the spring (17); • does not trip before the expected pressure value, screw in (clockwise) the adjustment ring nut (15) so as to further compress the spring (17). </div>
3	Move the slam-shut valve to open by acting on the reset lever (16) and keep it open manually.
4	Increase the downstream pressure to the set value of the regulator by turning the main regulator pilot adjustment screw.
5	Reset the slam-shut valve.
6	Check the minimum pressure spring for proper calibration by repeating steps 1-2-3-4 at least three times.
7	Close the drain cock (Fig. 8.32, ref.6).

Tab. 8.78.

COMMISSIONING THE REGULATOR

! NOTICE!

Please refer to "8.5 - Regulator commissioning procedure" of this chapter.

8.10 - COMMISSIONING PROCEDURE FOR THE REVAL 182 REGULATOR WITH BUILT-IN SLAM-SHUT VALVE SB/82

8.10.1 - CHECKING THE SB/82 SLAM-SHUT VALVE TIGHTNESS DURING SHUT-OFF

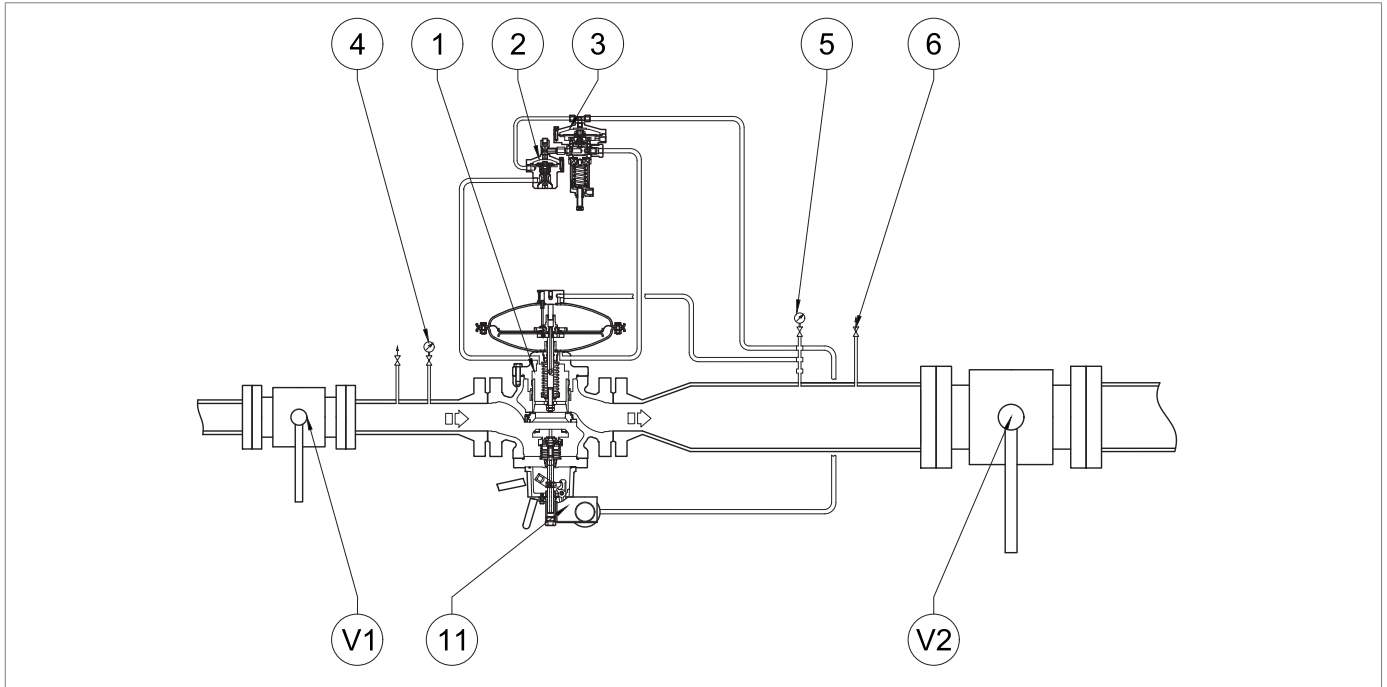

Fig. 8.38. Sealing of the SB/82 slam-shut valve during shut-off

Step	Action
1	Check that the slam-shut valve is in the shut-off position.
2	Open the drain cock (6) and drain the downstream section completely.
3	Slowly open upstream valve V1.
4	Check the tightness of the slam-shut valve through the pilot circuit supply connection located under the regulator head, disconnecting the connection from the regulator. <div style="border: 1px solid blue; padding: 5px; margin-top: 5px;"> <p>NOTICE!</p> <ul style="list-style-type: none"> • Check the seal with a foaming substance; • In case of leaks from the connection, see chapter “10 - Troubleshooting” to remove the causes of the dysfunction. </div>
5	Reconnect the power connection of the drive circuit. <div style="border: 1px solid blue; padding: 5px; margin-top: 5px;"> <p>NOTICE!</p> <p>Check whether to replace the fitting by referring to the fitting manufacturer’s instructions.</p> </div>

Tab. 8.79.

PAGE INTENTIONALLY LEFT BLANK

8.10.2 - CALIBRATION PROCEDURE FOR PRESSURE SWITCHES MOD. 100

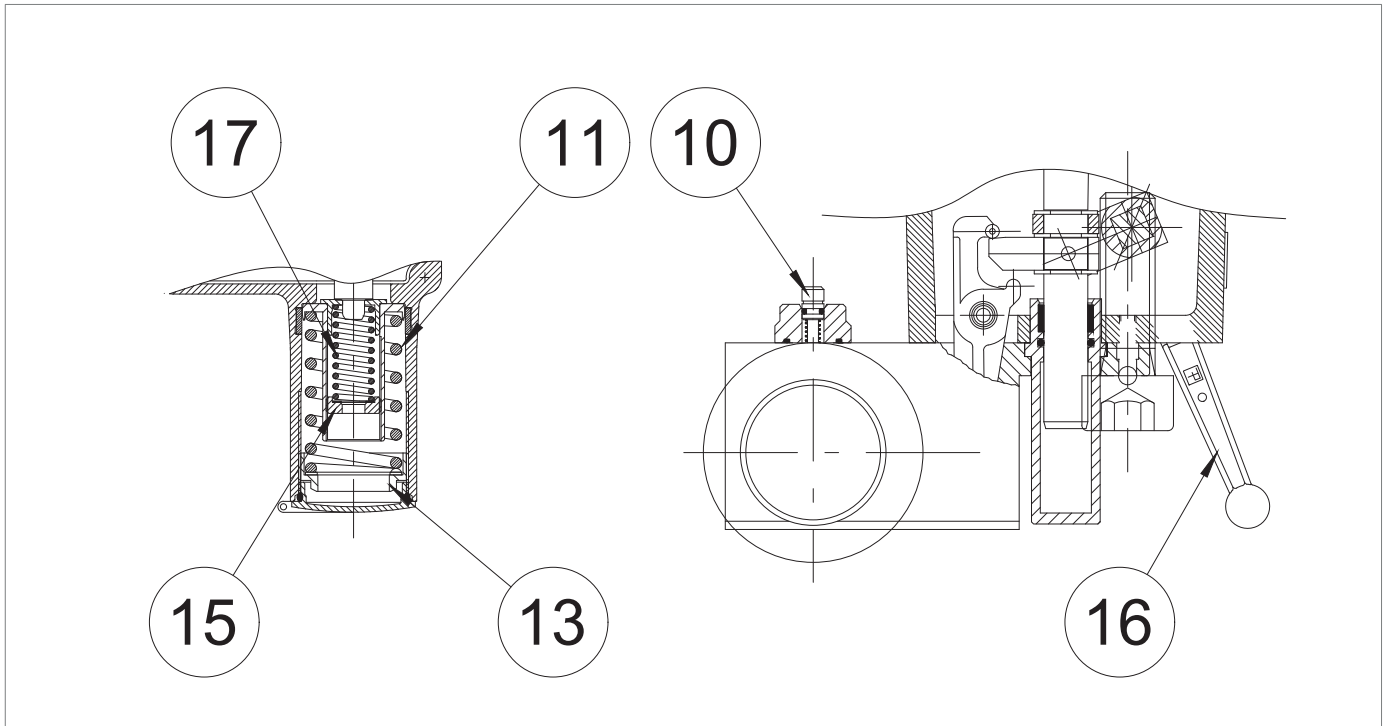

Fig. 8.39. Calibration of pressure switches mod. 100

SPRING SETTING FOR MAXIMUM PRESSURE TRIPPING

Step	Action
1	<p>Increase the downstream pressure to the slam-shut valve's cut-out value by turning the main regulator's pilot adjustment screw to check that the setting is correct.</p> <div style="border: 1px solid black; padding: 5px;"> <p>! NOTICE!</p> <p>Check the pressure referring to the pressure gauge (Fig. 8.32, ref.5) downstream of the main regulator.</p> <p>If the slam-shut valve:</p> <ul style="list-style-type: none"> • trips before the expected pressure value: screw in (clockwise) the adjustment ring nut (13) so as to further compress the spring (11); • does not trip at the expected pressure value: unscrew (anti-clockwise) the adjustment ring nut (13) so as to relieve the spring (11). </div>
2	By opening the drain cock (Fig. 8.32, ref. 6), decrease the pressure in the downstream section to the calibration value of the main regulator.
3	Close the bleed cock (Fig. 8.32, ref.6).
4	Reset the slam-shut device by adjusting the reset lever (16).
5	<p>Repeat steps 2-3-4 at least three times.</p> <div style="border: 1px solid black; padding: 5px;"> <p>! NOTICE!</p> <p>The calibration value must comply with the operating limits specified on the plate.</p> </div>

Tab. 8.80.

SPRING SETTING FOR MINIMUM PRESSURE TRIPPING (IF PRESENT)

Step	Action
1	Partially open the drain cock (Fig. 8.32, ref.6) to the atmosphere and keep it open for the next steps.
2	<p>Decrease the downstream pressure to the minimum required slam-shut device pressure by turning the main regulator's pilot adjustment screw.</p> <div style="border: 1px solid black; padding: 5px;"> <p>! NOTICE!</p> <p>Check the pressure referring to the downstream pressure gauge (Fig. 8.32, ref. 5).</p> <p>If the slam-shut valve:</p> <ul style="list-style-type: none"> • trips before the expected pressure value: unscrew (anti-clockwise) the adjustment ring nut (15) so as to relieve the spring (17); • does not trip before the expected pressure value, screw in (clockwise) the adjustment ring nut (15) so as to further compress the spring (17). </div>
3	Move the lock into the open position by means of the reset lever (16) and keep it open manually.
4	Increase the downstream pressure to the set value of the regulator by turning the main regulator pilot adjustment screw.
5	Reset the slam-shut device.
6	Check the minimum pressure spring for proper calibration by repeating steps 1-2-3-4 at least three times.
7	Close the bleed cock (Fig. 8.32, ref.6).

Tab. 8.81.

COMMISSIONING THE REGULATOR

! NOTICE!

Please refer to "8.5 - Regulator commissioning procedure" of this chapter.

8.11 - REGULATOR COMMISSIONING PROCEDURE REVAL 182 WITH HB/97 SLAM SHUT VALVE

8.11.1 - CHECKING THE SB/97 SLAM-SHUT VALVE FOR SEALING DURING SHUT-OFF

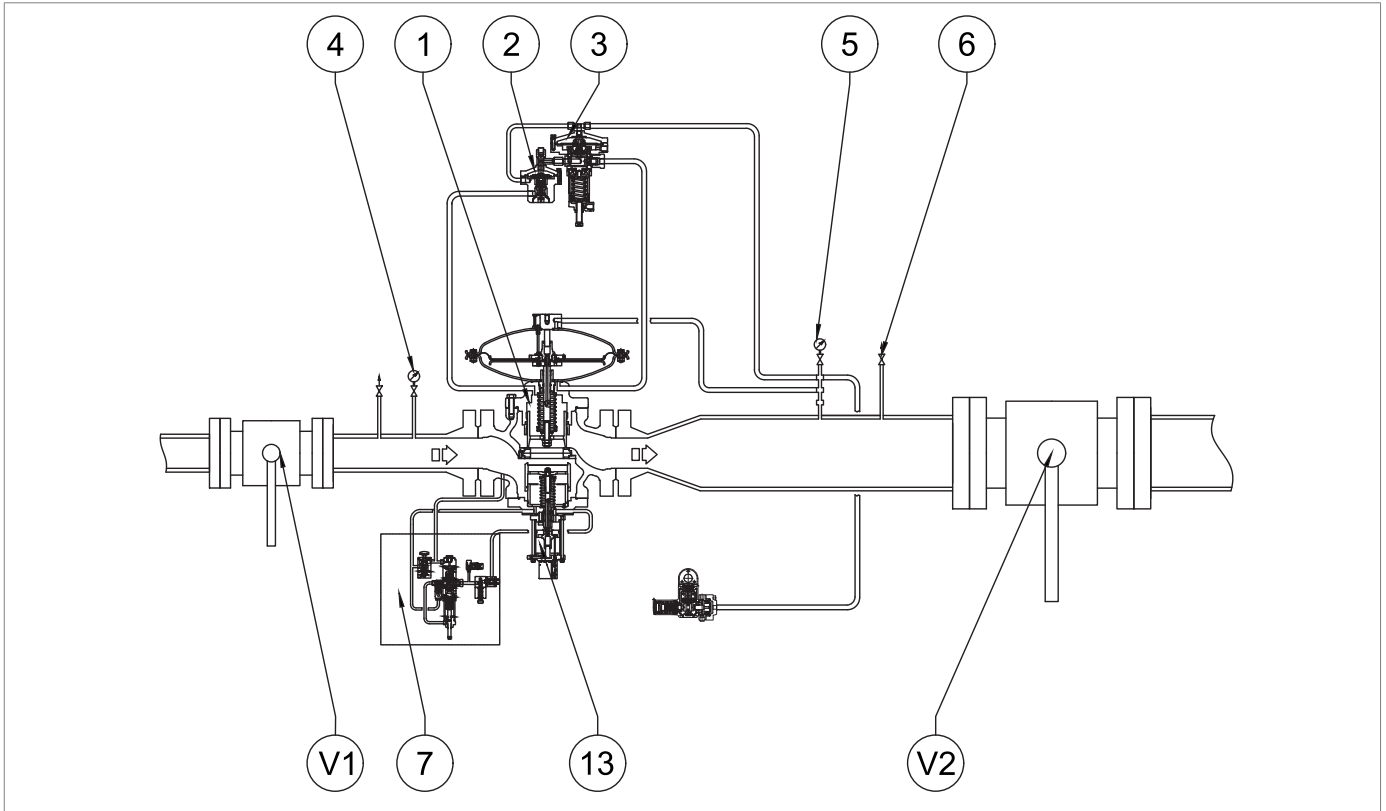

Fig. 8.40. Sealing of the HB/ 97 slam-shut valve during shut-off

Step	Action
1	Check that the slam-shut valve is in the shut-off position.
2	Open the drain cock (6) and drain the downstream section completely.
3	Slowly open upstream valve V1.
4	Check the tightness of the slam-shut valve through the pilot circuit supply connection located under the regulator head, disconnecting the connection from the regulator. <div style="border: 1px solid blue; padding: 5px; margin-top: 5px;"> <p>! NOTICE!</p> <ul style="list-style-type: none"> • Check the seal with a foaming substance; • In case of leaks from the connection, see chapter “10 - Troubleshooting” to remove the causes of the dysfunction. </div>
5	Reconnect the power connection of the drive circuit. <div style="border: 1px solid blue; padding: 5px; margin-top: 5px;"> <p>! NOTICE!</p> <p>Check whether to replace the fitting by referring to the fitting manufacturer’s instructions.</p> </div>

Tab. 8.82.

PAGE INTENTIONALLY LEFT BLANK

8.11.2 - COMMISSIONING PROCEDURE AND CALIBRATION OF THE LINE OFF 2.0 DEVICE FOR SLAM-SHUT VALVE HB/97

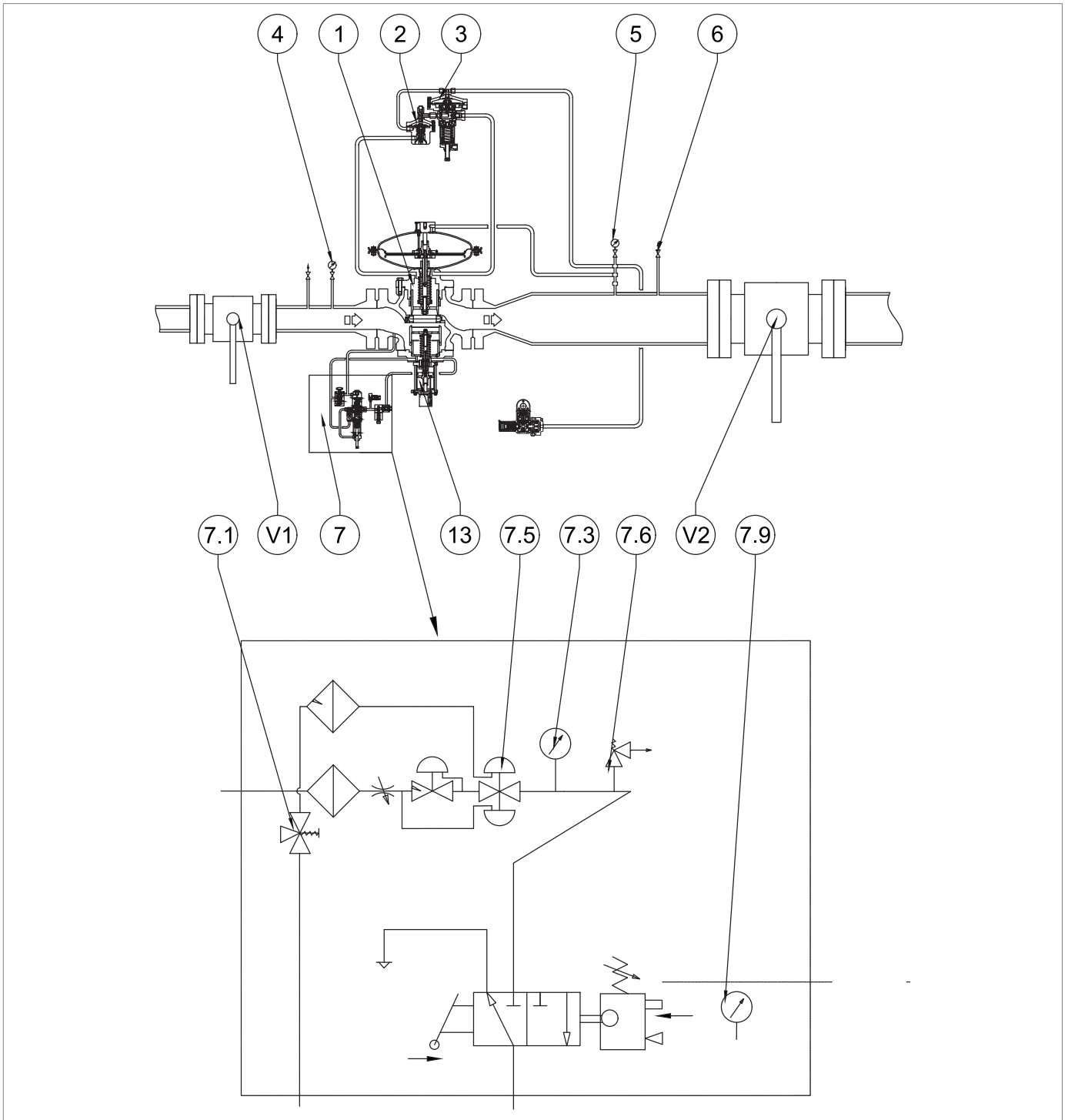



Fig. 8.41. Commissioning and calibration of LINE OFF 2.0 for HB/97 slam-shut valve

Step	Action
1	Press and hold the button of the bypass valve HP2/2 (7.1) to: <ul style="list-style-type: none"> bring the upstream pressure to the power supply unit of the LINE-OFF 2.0 device; balance the pressure of the HB/97 built-in slam-shut valve plug.
2	Release the button of bypass valve HP2/2 (7.1) after checking that the upstream and downstream pressure of the slam-shut valve is balanced.
3	Turn the adjusting screw of the R44/SS regulator (7.5) clockwise and tighten it until reaching the tripping value (6 bar) of the safety valve VS/FI (7.6). <div style="border: 1px solid black; padding: 5px; margin-top: 10px;">  NOTICE! Check the pressure, referring to the pressure gauge (7.3) connected to the R44/SS regulator. </div>
4	If the safety valve VS/FI (7.6): <ul style="list-style-type: none"> opens before the expected pressure value, unscrew the shaft collar nut and tighten (clockwise) the adjustment plug so that the spring inside it is further compressed; does not open at the expected pressure value, unscrew the shaft collar nut and loosen the adjustment plug anti-clockwise, so as to release the spring inside.
5	Check the VS/FI valve (7.6) for correct calibration: <ul style="list-style-type: none"> decreasing the pressure by adjusting the adjusting screw of the R44/SS regulator (7.5); increasing the pressure until the VS/FI valve (7.6) trips by turning the adjusting screw of the R44/SS regulator (7.5).
6	Repeat step 5 at least three times to properly calibrate the VS/FI safety valve (7.6).
7	By turning the adjusting screw, calibrate the R44/SS regulator (7.5) to the required pressure value (min. 4 bar, max. 5 bar) referring to the connected pressure gauge (7.3), then: <ul style="list-style-type: none"> if the pressure value on the pressure gauge is lower than the set value of the R44/SS regulator (7.5): tighten the adjusting screw clockwise so as to further compress the spring inside it; if the pressure value on the pressure gauge is higher than the calibration value of the R44/SS regulator (7.5): unscrew the adjusting screw anti-clockwise so as to further release the spring inside.
8	Press the button of bypass valve HP2/2 (7.1) and check that the upstream and downstream pressure is balanced.
9	Release the HP2/2 bypass valve button (7.1).
10	Reset the HB/97 slam-shut valve by operating the lever (7.9).

Tab. 8.83.

COMMISSIONING THE REGULATOR

 **NOTICE!**

Please refer to “8.5 - Regulator commissioning procedure” of this chapter.

8.12 - CALIBRATION OF THE PRESSURE SWITCH FOR LINE OFF 2.0

 **NOTICE!**

For the pressure switch calibration procedure, please refer to “8.10.2 - Calibration procedure for pressure switches mod. 100”.

8.13 - DEVICE CALIBRATION

8.13.1 - V/25 ACCELERATOR VALVE CALIBRATION

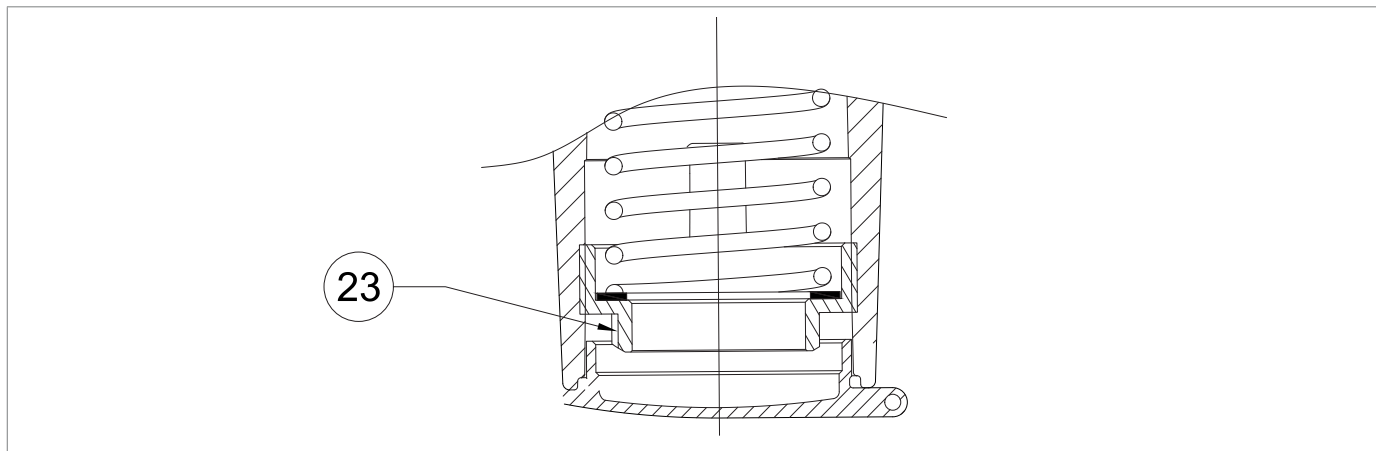

Fig. 8.42. V/25 Accelerator valve calibration

Adjust the adjustment ring nut (23):

- anticlockwise to decrease the adjusted pressure;
- clockwise to increase the adjusted pressure.

8.13.2 - CALIBRATION 200/A SERIES PILOTS AND M/A ACCELERATING VALVE

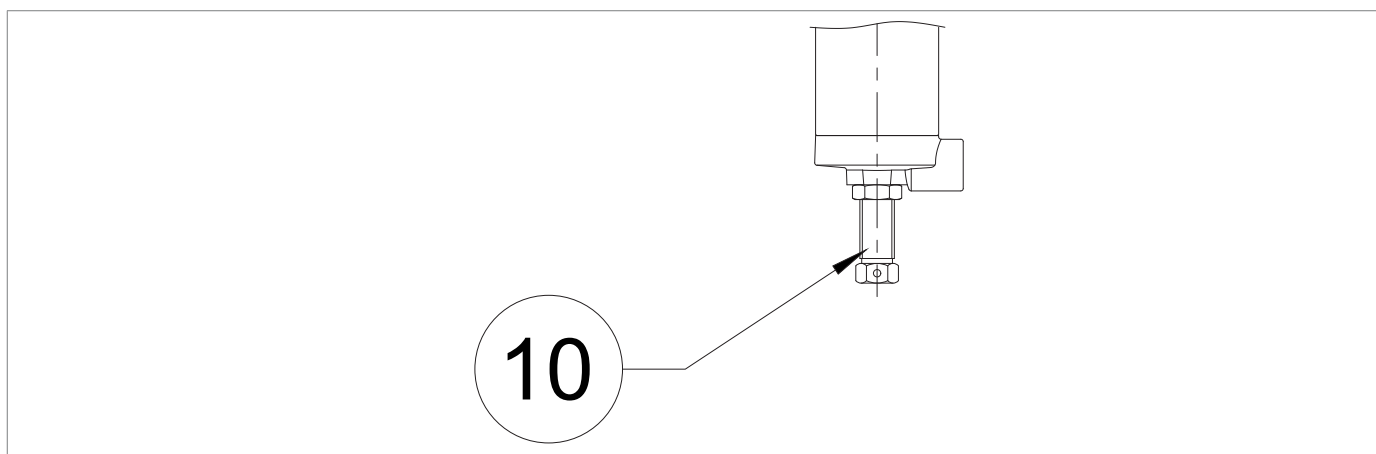

Fig. 8.43. 200/A series pilot calibration

Turn the adjusting screw (10):

- anticlockwise to decrease the adjusted pressure;
- clockwise to increase the adjusted pressure.

8.13.3 - CALIBRATION OF PRESSURE SWITCHES MOD. 100

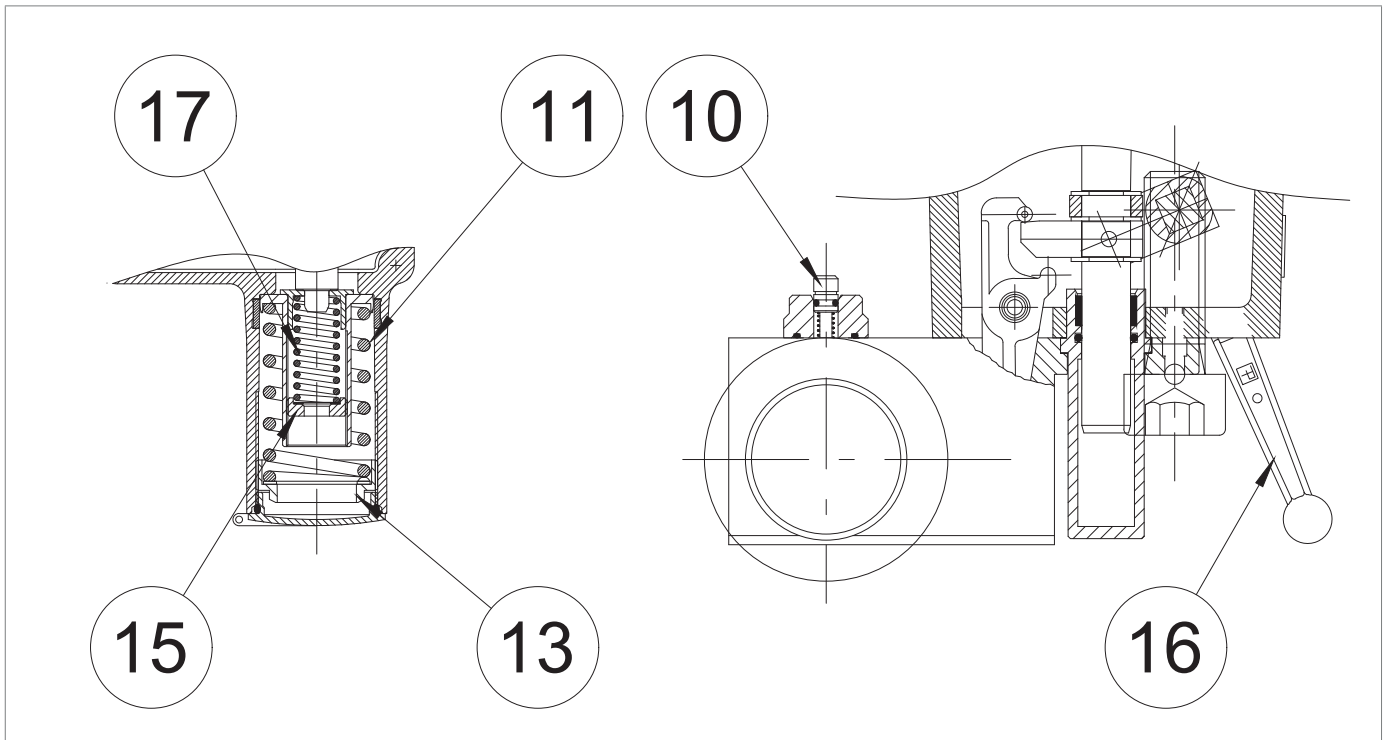

Fig. 8.44. Calibration of pressure switches mod. 100

Adjust the maximum pressure (11) ring nut (13):

- anti-clockwise to decrease the slam-shut device tripping pressure;
- clockwise to increase the slam-shut device tripping pressure.

Turn the minimum pressure (17) ring nut (15):

- anti-clockwise to decrease the slam-shut device tripping pressure;
- clockwise to increase the slam-shut device tripping pressure.

NOTICE!

For calibration ranges, please refer to chapter “13 - Calibration tables”.

ATTENTION!

After calibration of the pressure switch, remove the lever to avoid interference with other objects on the system.

8.13.4 - CALIBRATION OF PRESSURE SWITCHES MOD. SA

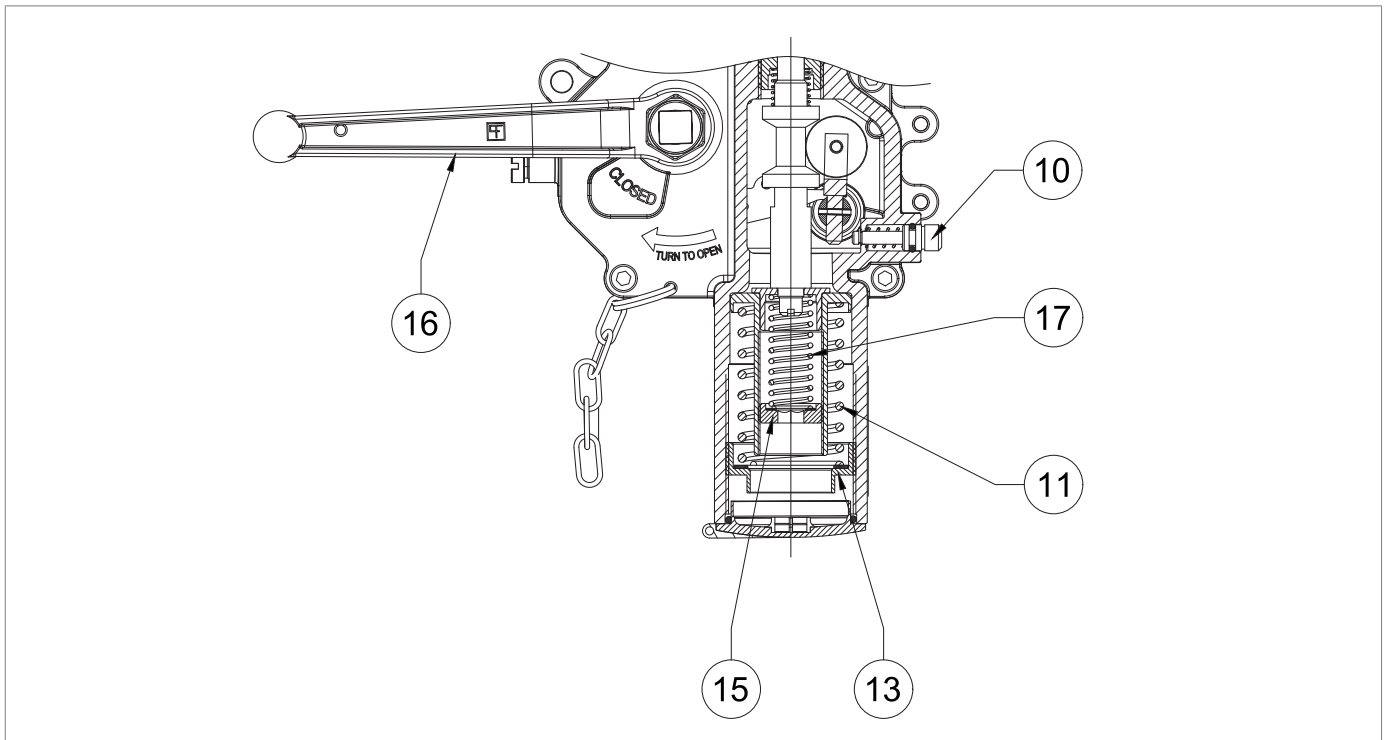

Fig. 8.45. Calibration of pressure switches mod. SA

Adjust the maximum pressure (11) ring nut (13):

- anti-clockwise to decrease the slam-shut device tripping pressure;
- clockwise to increase the slam-shut device tripping pressure.

Turn the minimum pressure (17) ring nut (15):

- anti-clockwise to decrease the slam-shut device tripping pressure;
- clockwise to increase the slam-shut device tripping pressure.

NOTICE!

For calibration ranges, please refer to chapter “13 - Calibration tables”.

ATTENTION!

After calibration of the pressure switch, remove the lever to avoid interference with other objects on the system.

9 - MAINTENANCE AND FUNCTIONAL CHECKS

9.1 - GENERAL WARNINGS

HAZARD!

- Maintenance work must be carried out by qualified personnel trained on safety in the workplace and authorised to carry out equipment-related activities.
- Each maintenance operation requires in-depth and specialised knowledge of the equipment, the necessary operations, the associated risks and the correct procedures to operate safely.
- Repair or maintenance work not provided for in this manual may be carried out only if approved by PIETRO FIORENTINI S.p.A.. No liability for personal injury or damage to property can be attributed to PIETRO FIORENTINI S.p.A. for work other than that described or performed in a manner other than indicated.

WARNING!

Before any intervention, it is necessary:

- to ensure that the line on which the equipment is installed is shut off upstream and downstream;
 - to operate the slam shut valve in manual mode by pressing the release button (Pos. 10 - Figure 4.14.).
- Next, check that the pressure indicated by the pressure gauge installed on the LINE OFF 2.0 device (Pos. 7.3 - Figure 8.41.) is 0 bar, ensuring complete depressurisation of the line.

WARNING!

In case of doubt, do not perform any work. Contact PIETRO FIORENTINI S.p.A. for the necessary clarifications.

The management and/or use of the equipment includes interventions that are necessary as a result of normal use such as:

- inspection and checks;
- functional checks;
- routine maintenance;
- special maintenance.

NOTICE!

Maintenance work is strictly related to:

- the quality of the conveyed gas (impurities, humidity, gasoline, corrosive substances);
- the effectiveness of filtration;
- the conditions of use of the equipment.

To properly run the equipment, one should:

- follow the service frequency referred to in the manual for functional checks and routine maintenance.
- not exceed the time interval between one service and the next. The time interval is to be understood as the maximum acceptable; it can, however, be shortened;
- promptly check the causes of any anomalies such as excessive noise, leakage of fluids or similar and remedy them. The timely removal of any causes of anomaly and/or malfunction prevents further damage to the equipment and ensures operator safety;

Before beginning disassembly of the equipment, make sure that:

- the spare parts and parts used in replacements have adequate requirements to ensure the original performance of the equipment. Use original, compliant spare parts;
- the operator must have the necessary equipment (see chapter “7 - Commissioning/maintenance equipment”).

! NOTICE!

The recommended spare parts are unambiguously identified with tags indicating:

- **the assembly drawing number of the equipment in which they are to be used (see chapter “12 - Recommended spare parts”);**
- **the position shown in the assembly drawing of the equipment.**



The equipment maintenance operations are divided, from an operational point of view, into three main categories:

Commissioning and maintenance operations

Periodic checks and inspections	All those checks that the operator must carry out on a regular basis to ensure that the equipment is in proper working order.
Routine maintenance	All those operations that the operator must preventively carry out to ensure proper operation of the device over time. Routine maintenance includes: <ul style="list-style-type: none"> • inspection; • control; • adjustment; • cleaning; • lubrication; • replacement; of all spare parts.
Special maintenance	All those operations to be carried out by the operator when the equipment requires them.

Tab. 9.84.

9.2 - PERIODICALLY CHECKING AND INSPECTING THE EQUIPMENT FOR PROPER OPERATION

Periodic checks and inspections	
Operator qualification	Mechanical maintenance technician
PPE required	 <div style="background-color: orange; padding: 5px; margin-top: 10px;">  WARNING! </div> <p>The PPE listed in this table is related to the risk associated with the equipment. For the required PPE to protect against risks associated with the workplace, installation or operating conditions, please refer to:</p> <ul style="list-style-type: none"> • the regulations in force in the country of installation; • <u>any information provided by the Safety Manager at the installation facility.</u>

Tab. 9.85.

Tab. 9.86 lists checks and verifications, i.e. operations that do not require any manual intervention on the individual equipment.

Some items thereof can be replaced remotely using suitable remote control tools:

Activity description	Equipment/accessories involved	Evaluation criterion	Minimum frequency
Control of significant performance*	Pressure regulators	<ul style="list-style-type: none"> • No fluctuations in the adjusted pressure. • Significant pressure values within pre-set limits. 	Monthly
	Gas flow slam-shut type safety devices (external position indicator)	<ul style="list-style-type: none"> • Fully open position. 	
	Stand-by monitor (external position indicator)	<ul style="list-style-type: none"> • Fully open position. 	
Visual inspection of external status of the equipment	All	<ul style="list-style-type: none"> • No visible damage. • External surface protection as per UNI 9571-1:2012. 	Half-yearly

Tab. 9.86.

* These checks may be carried out remotely if there is a remote control system capable of analysing the significant performance of the equipment and of sending alerts/alarms when pre-set thresholds are reached.

9.3 - ROUTINE MAINTENANCE

9.3.1 - GENERAL SAFETY WARNINGS

HAZARD!

- Put the equipment in a safe condition (close the downstream shut-off valve and then the upstream one, and drain the line completely);
- Ensure that the pressure upstream and downstream of the equipment is 0.

WARNING!

Before any intervention, it is necessary:

- to ensure that the line on which the equipment is installed is shut off upstream and downstream;
 - to operate the slam shut valve in manual mode by pressing the release button (Pos. 10 - Figure 4.14.).
- Next, check that the pressure indicated by the pressure gauge installed on the LINE OFF 2.0 device (Pos. 7.3 - Figure 8.41.) is 0 bar, ensuring complete depressurisation of the line.

NOTICE!

Before installing new sealing elements (o-rings, diaphragm, etc.), their integrity must be checked.

9.3.2 - REPLACEMENT FREQUENCY FOR COMPONENTS SUBJECT TO WEAR

NOTICE!

The following provisions shall apply to equipment components only.

The non-metallic parts of the equipment concerned are divided into the following two categories:

Preventive maintenance work

Category 1	Parts subject to wear and/or abrasion, where: <ul style="list-style-type: none"> wear and tear means the normal degradation of a part after prolonged use under normal operating conditions; abrasion is the mechanical action on the surface of the affected part resulting from the passage of gas under normal operating conditions.
Category 2	Parts subject to aging only, including parts that also require lubrication and/or cleaning.

Tab. 9.87.

NOTICE!







Check, within the minimum frequency specified in Tab. 9.88, the available components for wear/abrasion/aging.

Category	Part description	Evaluation criterion	Minimum replacement frequency
1	Valve seat sealing rings and non-metallic plugs	Pressure regulators	6 years
		Safety devices	
		Pressure safety system equipment	
1	Non-metallic parts with internal sealing function of valve seats and accessories of individual equipment	Pilots	6 years
		Pre-regulators	
		Accelerators	
		Any others	
1	Non-metallic parts with a sealing function between parts, at least one of which is in motion under normal working/operating conditions	Pressure regulators	6 years
		Gas flow slam-shut type safety devices	
		Relief devices with discharge to atmosphere	
1	Non-metallic parts with sealing function involved in disassembly operations during maintenance	Equipment subject to maintenance	6 years
2	Non-metallic parts providing feedback (sensing elements) of the controlled pressure of safety equipment.	Safety equipment and/or accessories	6 years
2	Non-metallic parts with sealing and performance functions (diaphragms) of equipment	Pressure regulators and accessories	6 years
		Gas flow slam-shut type safety devices	6 years
		Relief device with discharge to atmosphere	6 years

Category	Part description	Evaluation criterion	Minimum replacement frequency
2	Non-metallic parts of equipment with an internal sealing function: under normal operating conditions during maintenance	Relief valves	6 years
		Regulation lines disconnection equipment	In the presence of ascertained leaks
2	Non-metallic parts with a static sealing function only	Various equipment	In the presence of ascertained leaks
2	Lubricating parts	Shut-off valves	Yearly
		Other equipment	Yearly
2	Filter elements	Filters	As needed

Tab. 9.88.

9.4 - ROUTINE MAINTENANCE PROCEDURES

Routine maintenance	
Operator qualification	Mechanical maintenance technician
PPE required	<div style="display: flex; justify-content: space-around; align-items: center;">      </div> <div style="background-color: #f4a460; padding: 5px; margin-top: 5px;">  WARNING! </div> <p>The PPE listed in this table is related to the risk associated with the equipment. For the required PPE to protect against risks associated with the workplace, installation or operating conditions, please refer to:</p> <ul style="list-style-type: none"> • the regulations in force in the country of installation; • <u>any information provided by the Safety Manager at the installation facility.</u>
Equipment required	Please refer to the chapter “7 - Commissioning/maintenance equipment”.

Tab. 9.89.

9.4.1 - TIGHTENING TORQUES REVAL 182

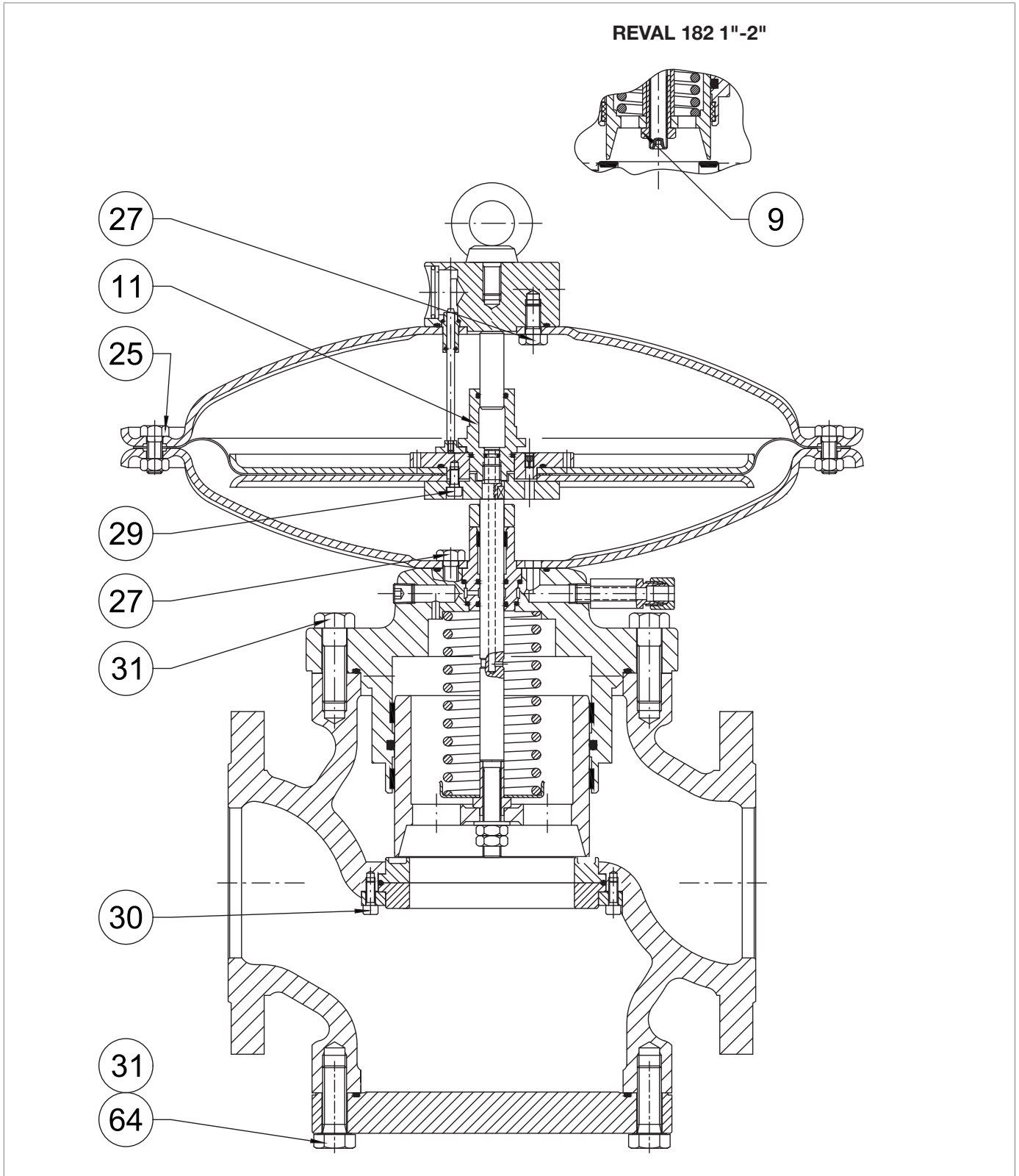

Fig. 9.46. Tightening torques REVAL 182

REVAL 182 1"			
Pos.	Description	Torque (Nm)	Torque (ft - lb)
9	Nut M12	35	25
11	M12 piston guide	35	25
25	Screw M10X25 UNI 5739	30	22
27	Screw M10X20 UNI 5739	45	33
29	Screw M6X14 UNI 5931	10	7
30	Screw M6X14 UNI 5931	10	7
31	Screw M10X30 UNI 5739	45	33

Tab. 9.90.

REVAL 182 2"			
Pos.	Description	Torque (Nm)	Torque (ft - lb)
9	Nut M12	35	25
11	M12 piston guide	35	25
25	Screw M10X25 UNI 5739	30	22
27	Screw M10X20 UNI 5739	45	33
29	Screw M6X14 UNI 5931	10	7
30	Screw M6X12 UNI 5931	10	7
31	Screw M12X35 UNI 5739	80	59

Tab. 9.91.

REVAL 182 2" ½			
Pos.	Description	Torque (Nm)	Torque (ft - lb)
11	M12 piston guide	35	25
25	Screw M10X25 UNI 5739	30	22
27	Screw M10X20 UNI 5739	45	33
29	Screw M6X14 UNI 5931	10	7
30	Screw M6X16 UNI 5931	10	7
31	Screw M12X40 UNI 5739	80	59
64	Screw M12X40 UNI 5739	80	59

Tab. 9.92.

REVAL 182 3"			
Pos.	Description	Torque (Nm)	Torque (ft - lb)
11	M12 piston guide	35	25
25	Screw M10X25 UNI 5739	30	22
27	Screw M10X20 UNI 5739	45	33
29	Screw M6X14 UNI 5931	10	7
30	Screw M6X16 UNI 5931	10	7
31	Screw M12X40 UNI 5739	80	59
64	Screw M12X40 UNI 5739	80	59

Tab. 9.93.

REVAL 182 1"-2"

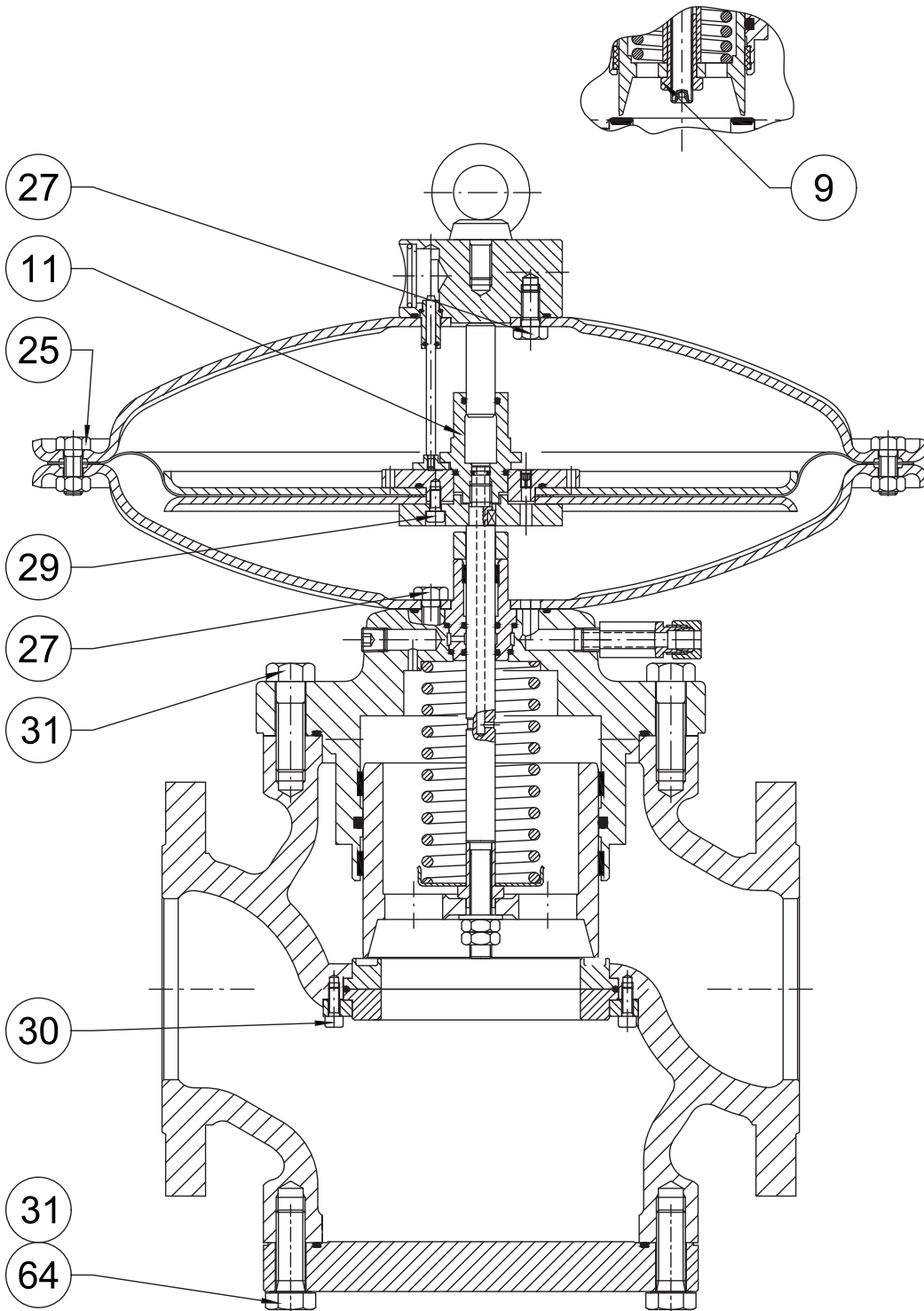

Tightening torques REVAL 182

REVAL 182 4"			
Pos.	Description	Torque (Nm)	Torque (ft - lb)
11	M12 piston guide	35	25
25	Screw M10X25 UNI 5739	30	22
27	Screw M10X20 UNI 5739	45	33
29	Screw M6X14 UNI 5931	10	7
30	Screw M6X16 UNI 5931	10	7
31	Screw M16X50 UNI 5737	100	73
64	Screw M16X50 UNI 5737	100	73

Tab. 9.94.

REVAL 182 6"			
Pos.	Description	Torque (Nm)	Torque (ft - lb)
11	Piston guide M18	110	81
25	Screw M10X25 UNI 5739	30	22
27	Screw M14X25 UNI 5739	115	84
29	Screw M6X16 UNI 5931	10	7
30	Screw M6X16 UNI 5931	10	7
31	Screw M14X50 UNI 5737	115	84
64	Screw M14X50 UNI 5737	115	84

Tab. 9.95.

REVAL 182 8"			
Pos.	Description	Torque (Nm)	Torque (ft - lb)
11	Piston guide M18	110	81
25	Screw M10X25 UNI 5739	30	22
27	Screw M14X25 UNI 5739	115	84
29	Screw M6X16 UNI 5931	10	7
30	Screw M6X16 UNI 5931	10	7
31	Screw M14X55 UNI 5737	115	84
64	Screw M14X55 UNI 5737	115	84

Tab. 9.96.

REVAL 182 10"			
Pos.	Description	Torque (Nm)	Torque (ft - lb)
11	Piston guide M18	110	81
25	Screw M10X35 UNI 5739	30	22
27	Screw M20X40 UNI 5739	300	221
29	Screw M6X16 UNI 5931	10	7
30	Screw M6X16 UNI 5931	10	7
31	Screw M16X90 UNI 5737	150	110
64	Screw M16X70 UNI 5737	150	110

Tab. 9.97.

9.4.1.1 - TIGHTENING TORQUES REVAL 182 + SILENCER DB/182

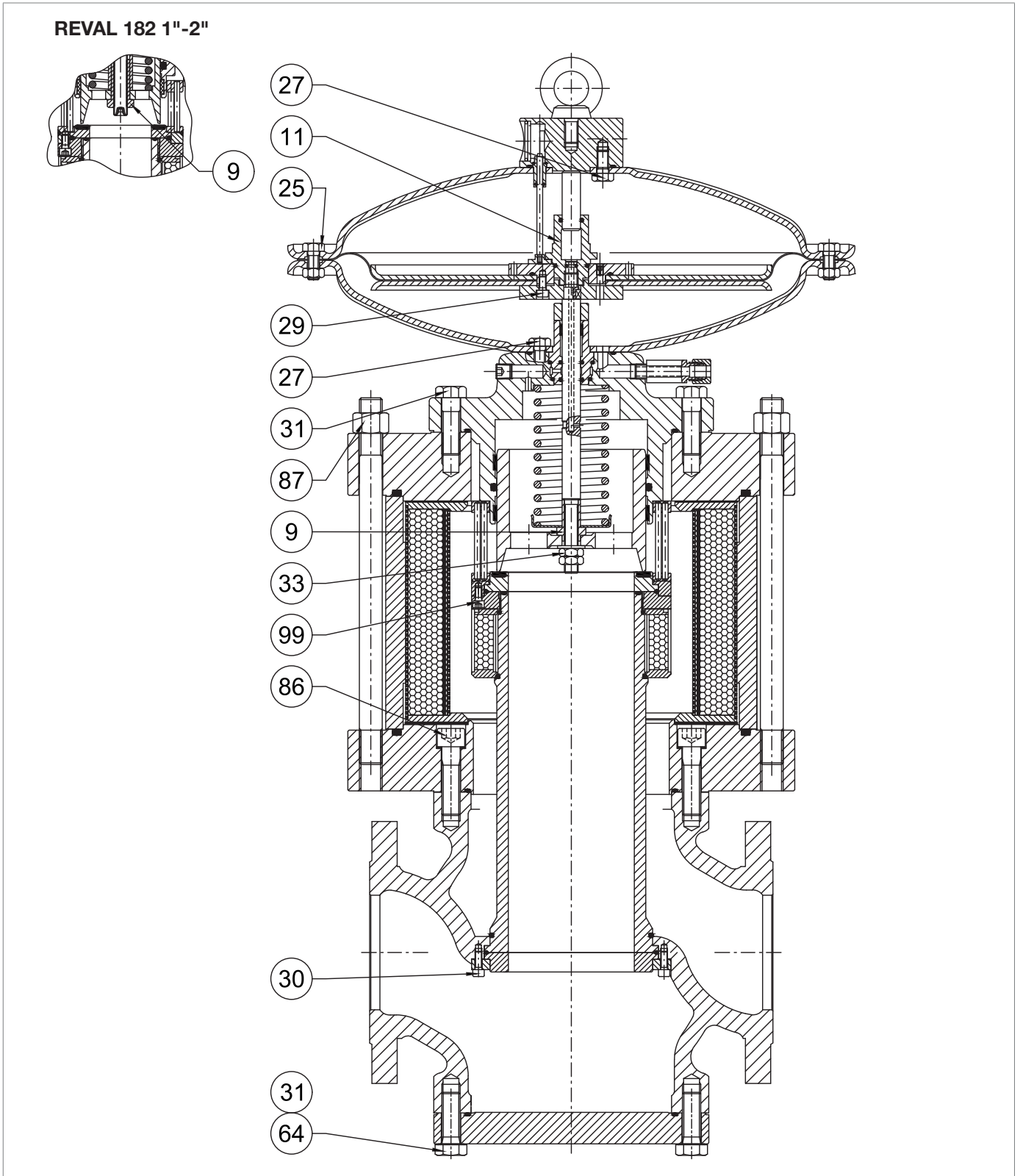

Fig. 9.47. Tightening torques REVAL 182 + Silencer DB/182

REVAL 182 1" + DB/182

Pos.	Description	Torque (Nm)	Torque (ft - lb)
9	Nut M12	35	25
11	M12 piston guide	35	25
25	Screw M10X25 UNI 5739	30	22
27	Screw M10X20 UNI 5739	45	33
29	Screw M6X14 UNI 5931	10	7
30	Screw M6X12 UNI 5931	10	7
31	Screw M10X30 UNI 5739	45	33
86	Screw M10X35 UNI 5931	45	33
87	Nut M14 UNI 5587	115	84
99	Screw M5X10 UNI 5931	6	4

Tab. 9.98.
REVAL 182 2" + DB/182

Pos.	Description	Torque (Nm)	Torque (ft - lb)
9	Nut M12	35	25
11	M12 piston guide	35	25
25	Screw M10X25 UNI 5739	30	22
27	Screw M10X20 UNI 5739	45	33
29	Screw M6X14 UNI 5931	10	7
30	Screw M6X12 UNI 5931	10	7
31	Screw M12X35 UNI 5739	80	59
86	Screw M12X35 UNI 5931	80	59
87	Nut M16 UNI 5588	150	110
99	Screw M6X12 UNI 5931	10	7

Tab. 9.99.

REVAL 182 1"-2"

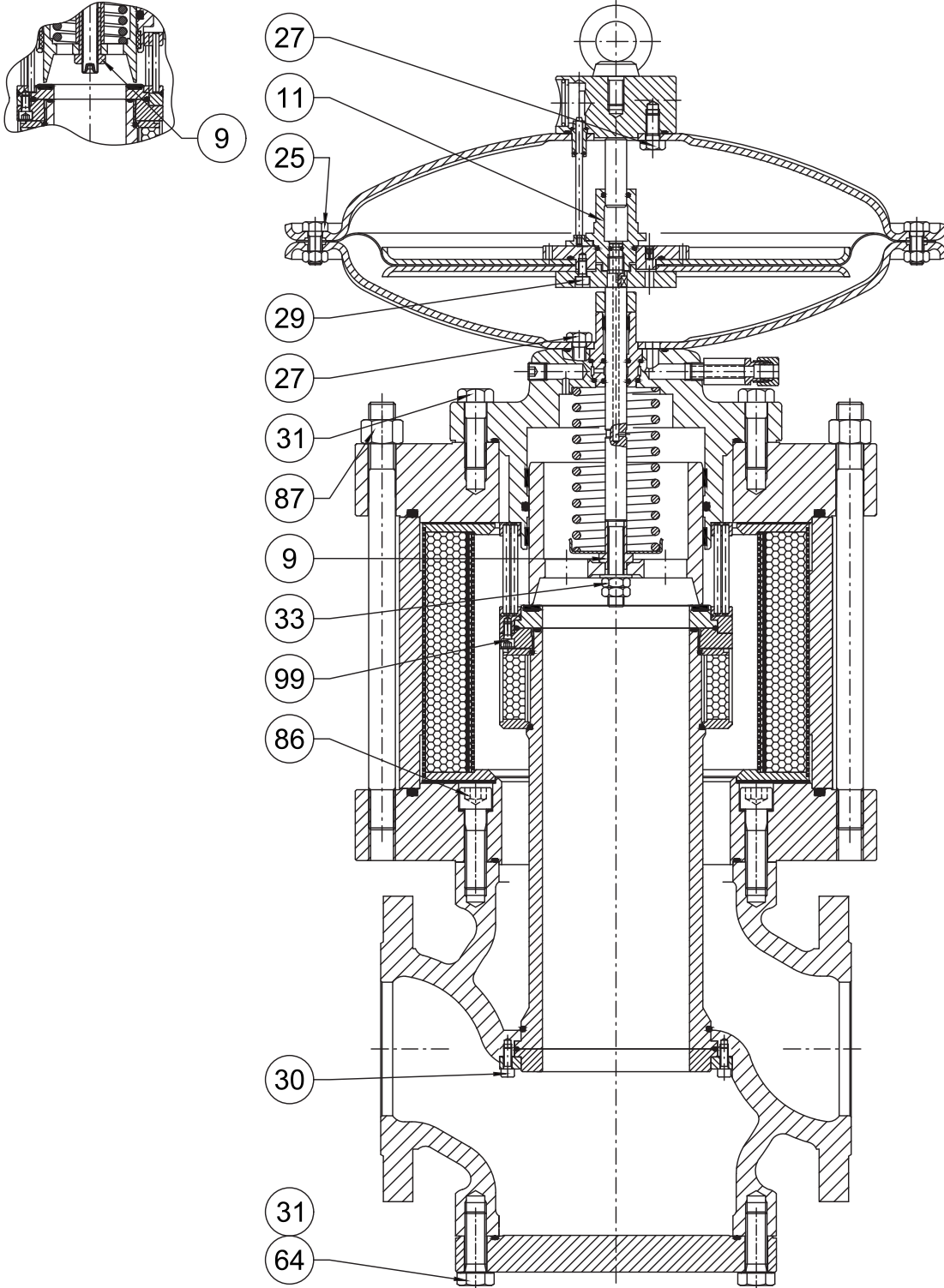

Tightening torques REVAL 182 + Silencer DB/182

REVAL 182 2" ½ + DB/182

Pos.	Description	Torque (Nm)	Torque (ft - lb)
11	M12 piston guide	35	25
25	Screw M10X25 UNI 5739	30	22
27	Screw M10X20 UNI 5739	45	33
29	Screw M6X14 UNI 5931	10	7
30	Screw M6X16 UNI 5931	10	7
31	Screw M12X40 UNI 5739	80	59
33	Nut M12 UNI 5589	35	25
64	Screw M12X40 UNI 5739	80	59
86	Screw M12X50 UNI 5931	80	59
87	Nut M18 UNI 5588	200	147
99	Screw M6X12 UNI 5931	10	7

Tab. 9.100.
REVAL 182 3" + DB/182

Pos.	Description	Torque (Nm)	Torque (ft - lb)
11	M12 piston guide	35	25
25	Screw M10X25 UNI 5739	30	22
27	Screw M10X20 UNI 5739	45	33
29	Screw M6X14 UNI 5931	10	7
30	Screw M6X16 UNI 5931	10	7
31	Screw M12X40 UNI 5739	80	59
33	Nut M12 UNI 5589	35	25
64	Screw M12X40 UNI 5739	80	59
86	Screw M12X50 UNI 5931	80	59
87	Nut M18 UNI 5588	200	147
99	Screw M6X12 UNI 5931	10	7

Tab. 9.101.

REVAL 182 1"-2"

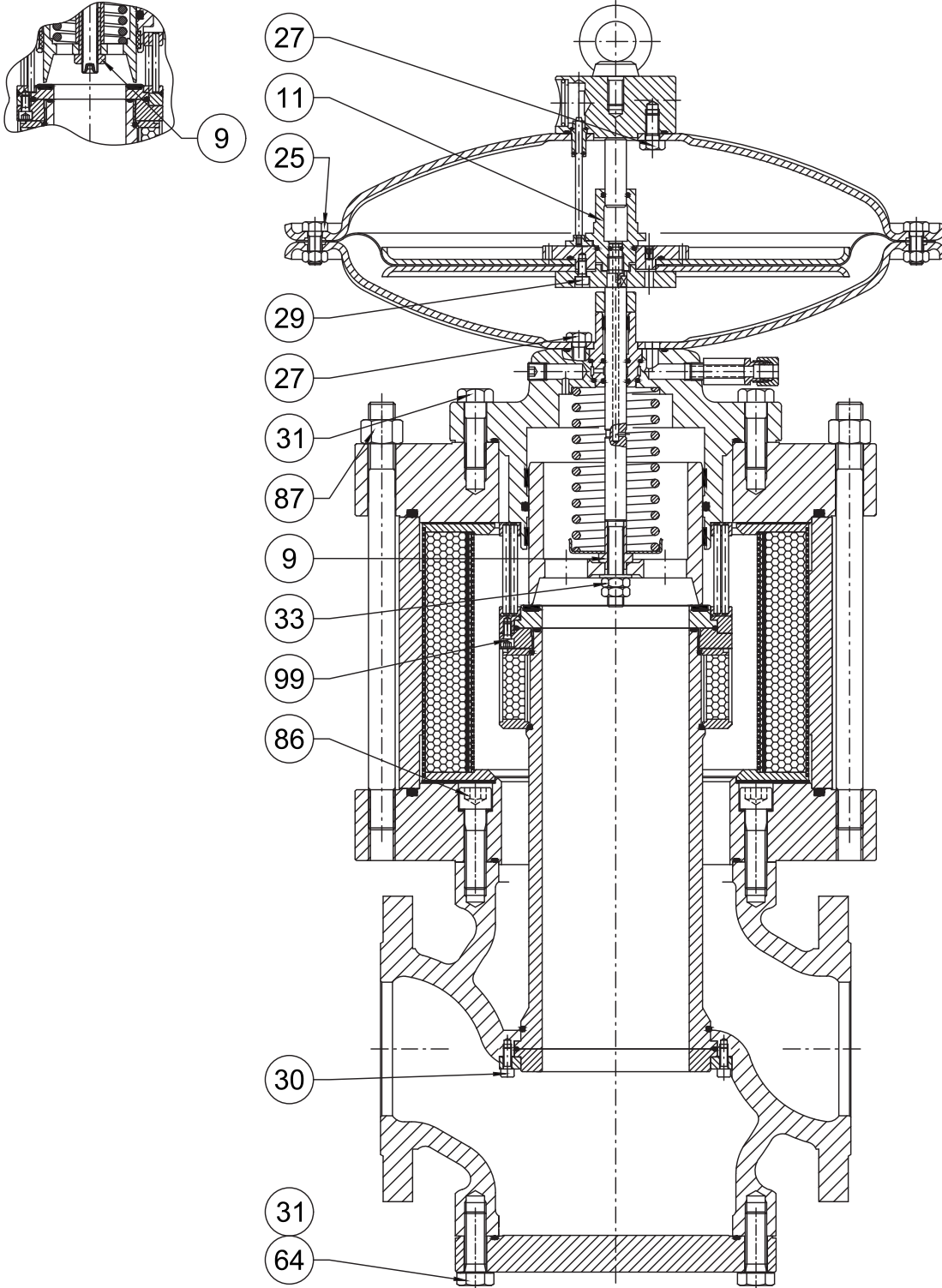

Tightening torques REVAL 182 + Silencer DB/182

REVAL 182 4" + DB/182

Pos.	Description	Torque (Nm)	Torque (ft - lb)
11	M12 piston guide	35	25
25	Screw M10X25 UNI 5739	30	22
27	Screw M10X20 UNI 5739	45	33
29	Screw M6X14 UNI 5931	10	7
30	Screw M6X16 UNI 5931	10	7
31	Screw M16X50 UNI 5737	150	110
33	Nut M12 UNI 5589	35	25
64	Screw M16X50 UNI 5737	150	110
86	Screw M16X60 UNI 5931	200	147
87	Nut M20 UNI 5588	250	184
99	Screw M6X12 UNI 5931	10	7

Tab. 9.102.
REVAL 182 6" + DB/182

Pos.	Description	Torque (Nm)	Torque (ft - lb)
11	Piston guide M18	110	81
25	Screw M10X25 UNI 5739	30	22
27	Screw M14X25 UNI 5739	115	84
29	Screw M6X16 UNI 5931	10	7
30	Screw M6X16 UNI 5931	10	7
31	Screw M14X50 UNI 5737	115	84
33	Nut M18 UNI 5589	110	81
64	Screw M14X50 UNI 5737	115	84
86	Screw M14X50 UNI 5931	130	95
87	Nut M22 UNI 5588	280	206
99	Screw M6X12 UNI 5931	10	7

Tab. 9.103.

REVAL 182 1"-2"

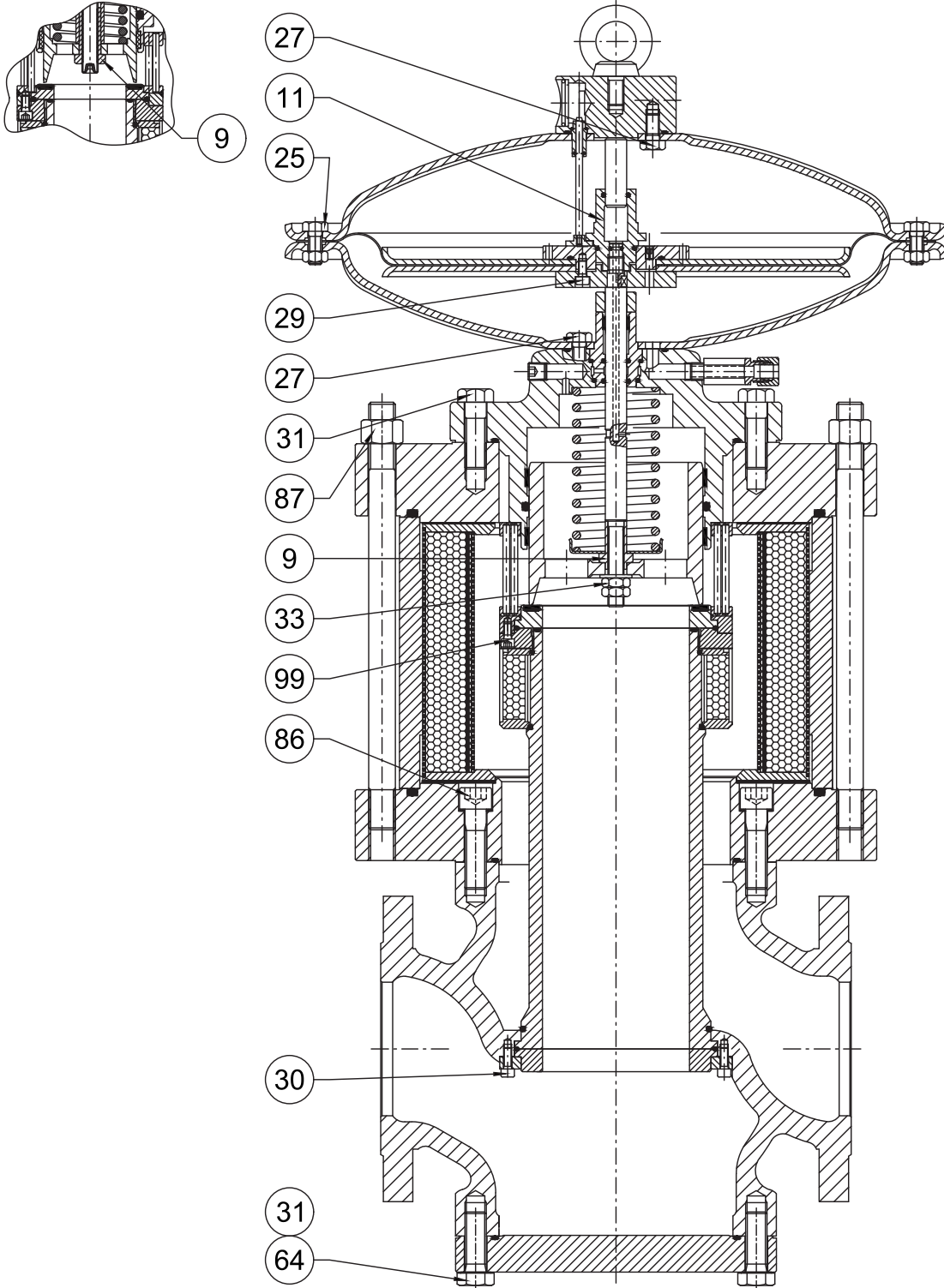

Tightening torques REVAL 182 + Silencer DB/182

REVAL 182 8" + DB/182

Pos.	Description	Torque (Nm)	Torque (ft - lb)
11	Piston guide M18	110	81
25	Screw M10X25 UNI 5739	30	22
27	Screw M14X25 UNI 5739	115	84
29	Screw M6X16 UNI 5931	10	7
30	Screw M6X16 UNI 5931	10	7
31	Screw M14X55 UNI 5737	115	84
33	Nut M18 UNI 5589	110	81
64	Screw M14X55 UNI 5737	115	84
86	Screw M14X50 UNI 5931	130	95
87	Nut M24 UNI 5587	300	221
99	Screw M6X12 UNI 5931	10	7

Tab. 9.104.
REVAL 182 10" + DB/182

Pos.	Description	Torque (Nm)	Torque (ft - lb)
11	Piston guide M18	110	81
25	Screw M10X35 UNI 5739	30	22
27	Screw M20X40 UNI 5739	300	221
29	Screw M6X16 UNI 5931	10	7
30	Screw M6X16 UNI 5931	10	7
31	Screw M16X90 UNI 5737	150	110
33	Nut M20 UNI 5589	150	110
64	Screw M16X70 UNI 5737	150	110
86	Screw M16X80 UNI 5931	200	147
87	Nut M24 UNI 5587	300	221
99	Screw M6X10 UNI 5931	10	7

Tab. 9.105.

9.4.1.2 - TIGHTENING TORQUES FOR PM/182 BUILT-IN MONITOR

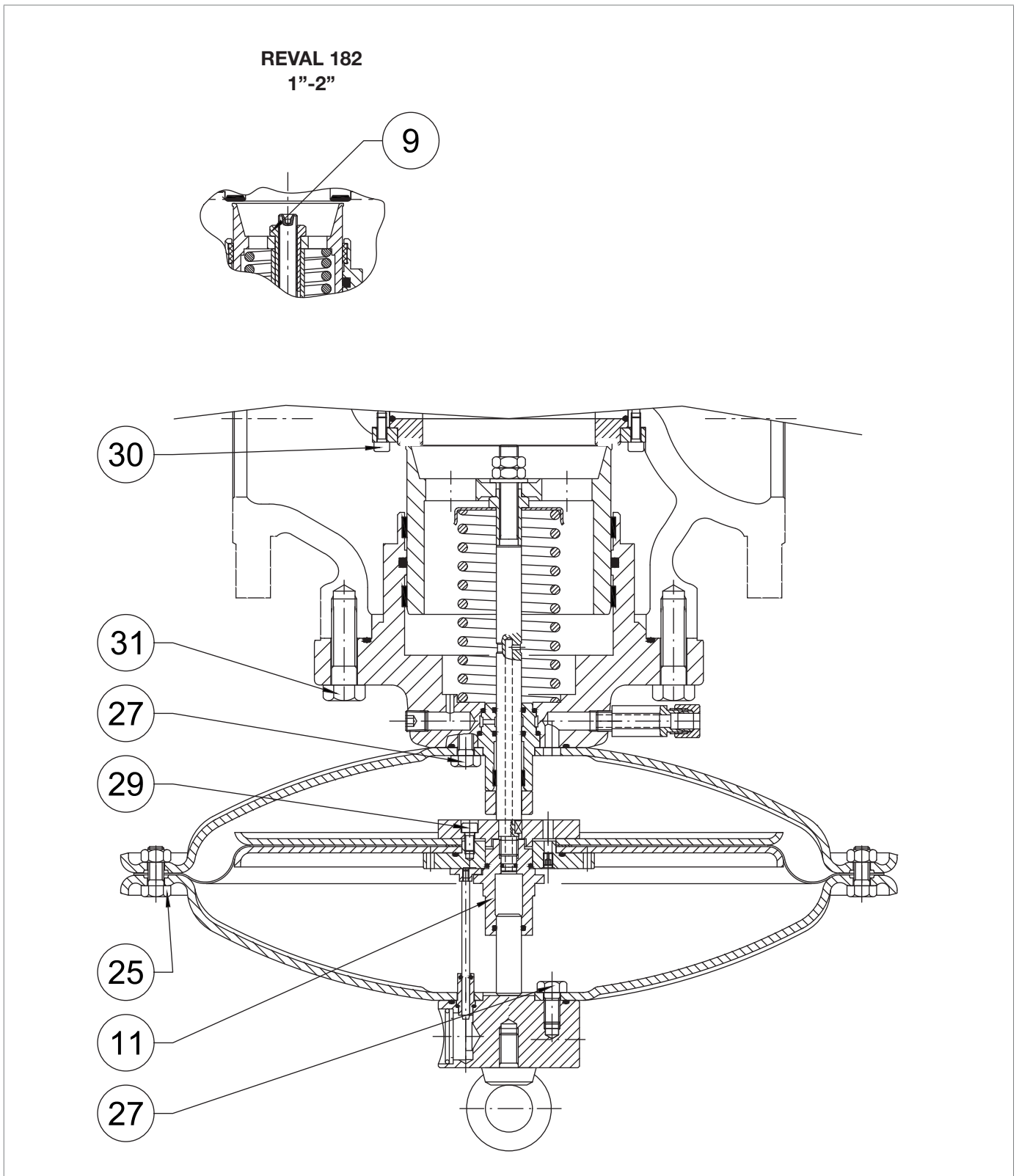

Fig. 9.48. Tightening torques for PM/182 built-in monitor

PM/182 1"			
Pos.	Description	Torque (Nm)	Torque (ft - lb)
9	Nut M12	35	25
11	M12 piston guide	35	25
25	Screw M10X25 UNI 5739	30	22
27	Screw M10X20 UNI 5739	45	33
29	Screw M6X14 UNI 5931	10	7
30	Screw M6X12 UNI 5931	10	7
31	Screw M10X30 UNI 5739	45	33

Tab. 9.106.

PM/182 2"			
Pos.	Description	Torque (Nm)	Torque (ft - lb)
9	Nut M12	35	25
11	M12 piston guide	35	25
25	Screw M10X25 UNI 5739	30	22
27	Screw M10X20 UNI 5739	45	33
29	Screw M6X14 UNI 5931	10	7
30	Screw M6X12 UNI 5931	10	7
31	Screw M12X35 UNI 5739	80	59

Tab. 9.107.

PM/182 2" ½			
Pos.	Description	Torque (Nm)	Torque (ft - lb)
11	M12 piston guide	35	25
25	Screw M10X25 UNI 5739	30	22
27	Screw M10X20 UNI 5739	45	33
29	Screw M6X14 UNI 5931	10	7
30	Screw M6X12 UNI 5931	10	7
31	Screw M12X40 UNI 5739	80	59

Tab. 9.108.

PM/182 3"			
Pos.	Description	Torque (Nm)	Torque (ft - lb)
11	M12 piston guide	35	25
25	Screw M10X25 UNI 5739	30	22
27	Screw M10X20 UNI 5739	45	33
29	Screw M6X14 UNI 5931	10	7
30	Screw M6X12 UNI 5931	10	7
31	Screw M12X40 UNI 5739	80	59

Tab. 9.109.

**REVAL 182
1"-2"**

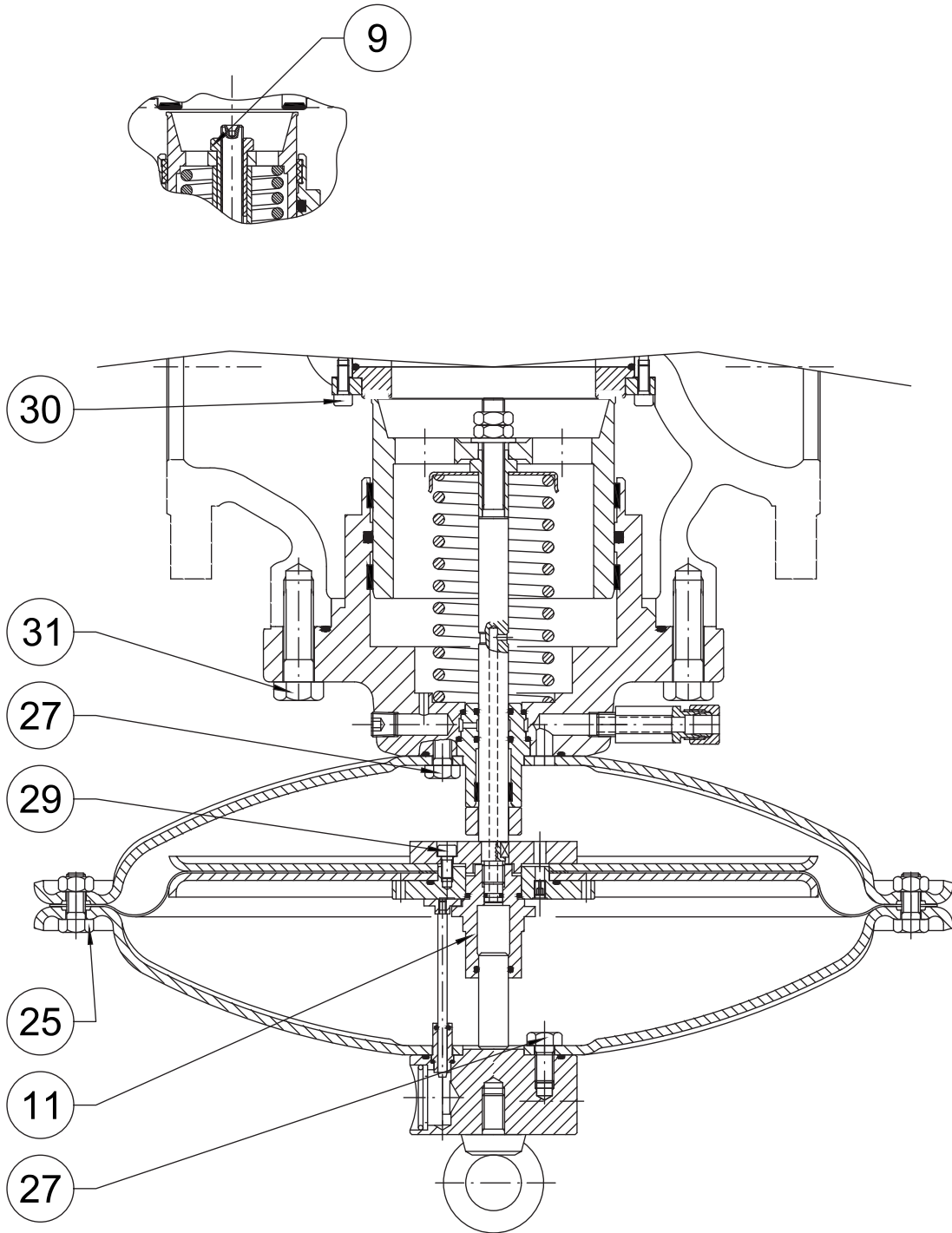

Tightening torques for PM/182 built-in monitor

PM/182 4"

Pos.	Description	Torque (Nm)	Torque (ft - lb)
11	M12 piston guide	35	25
25	Screw M10X25 UNI 5739	30	22
27	Screw M10X20 UNI 5739	45	33
29	Screw M6X14 UNI 5931	10	7
30	Screw M6X16 UNI 5931	10	7
31	Screw M16X50 UNI 5739	150	110

Tab. 9.110.
PM/182 6"

Pos.	Description	Torque (Nm)	Torque (ft - lb)
11	Piston guide M18	35	25
25	Screw M10X25 UNI 5739	30	22
27	Screw M10X20 UNI 5739	45	33
29	Screw M6X14 UNI 5931	10	7
30	Screw M6X16 UNI 5931	10	7
31	Screw M16X50 UNI 5739	150	110

Tab. 9.111.
PM/182 8"

Pos.	Description	Torque (Nm)	Torque (ft - lb)
11	Piston guide M18	110	81
25	Screw M10X25 UNI 5739	30	22
27	Screw M14X25 UNI 5739	115	84
29	Screw M6X16 UNI 5931	10	7
30	Screw M6X16 UNI 5931	10	7
31	Screw M14X55 UNI 5737	115	84

Tab. 9.112.

9.4.1.3 - TIGHTENING TORQUES 200/A SERIES PILOTS

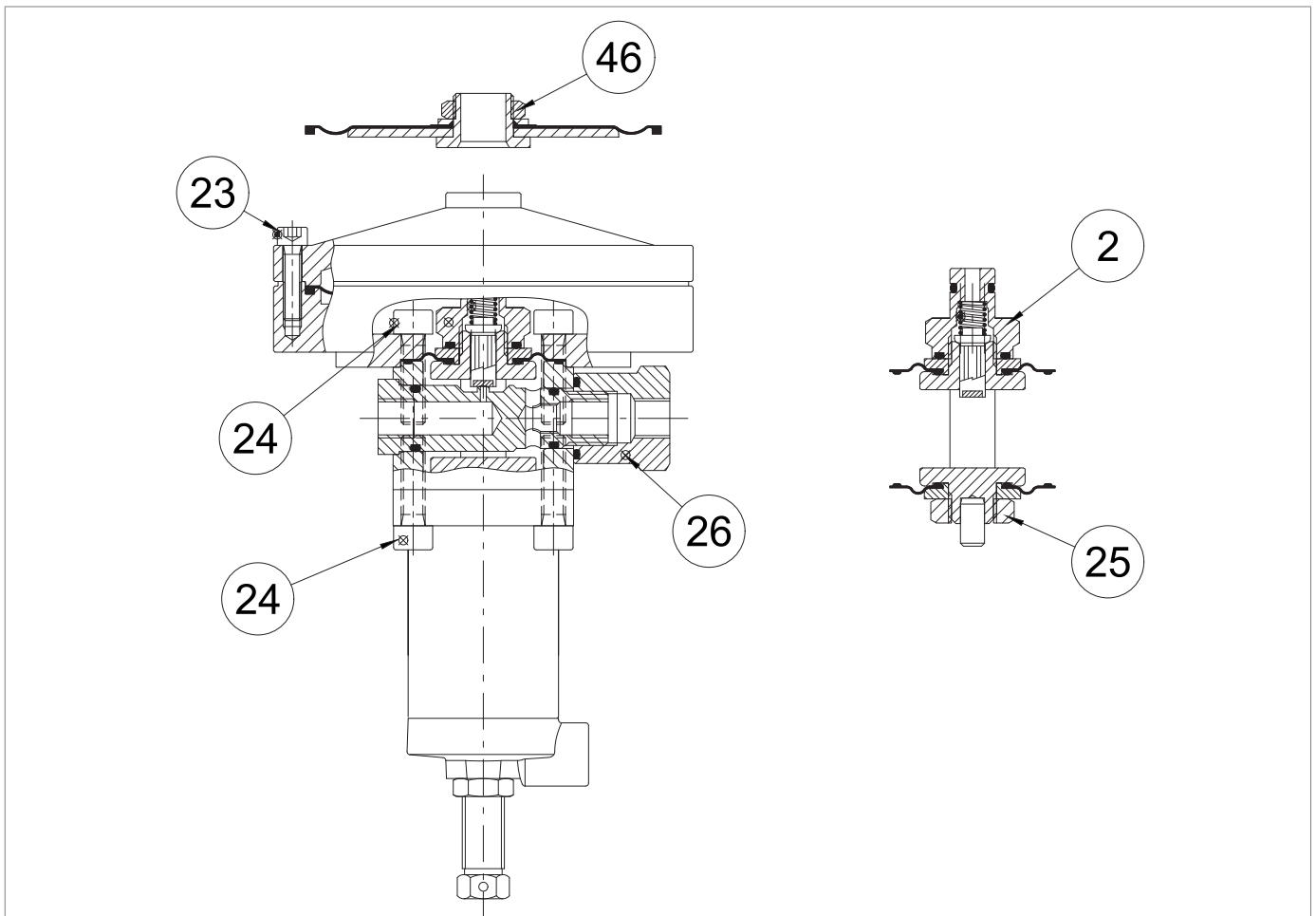

Fig. 9.49. Tightening torques for 201/A pilot

PILOTS 201/A			
Pos.	Description	Torque (Nm)	Torque (ft - lb)
2	Nut M16X1	25	18
23	Screw M6X25 UNI 5931	7	5
24	Screw M8X30 UNI 5931	20	14
25	Nut M16x1.5	25	18
26	Nut M16x1.5	20	14
46	Nut M20x1	8	5

Tab. 9.113.

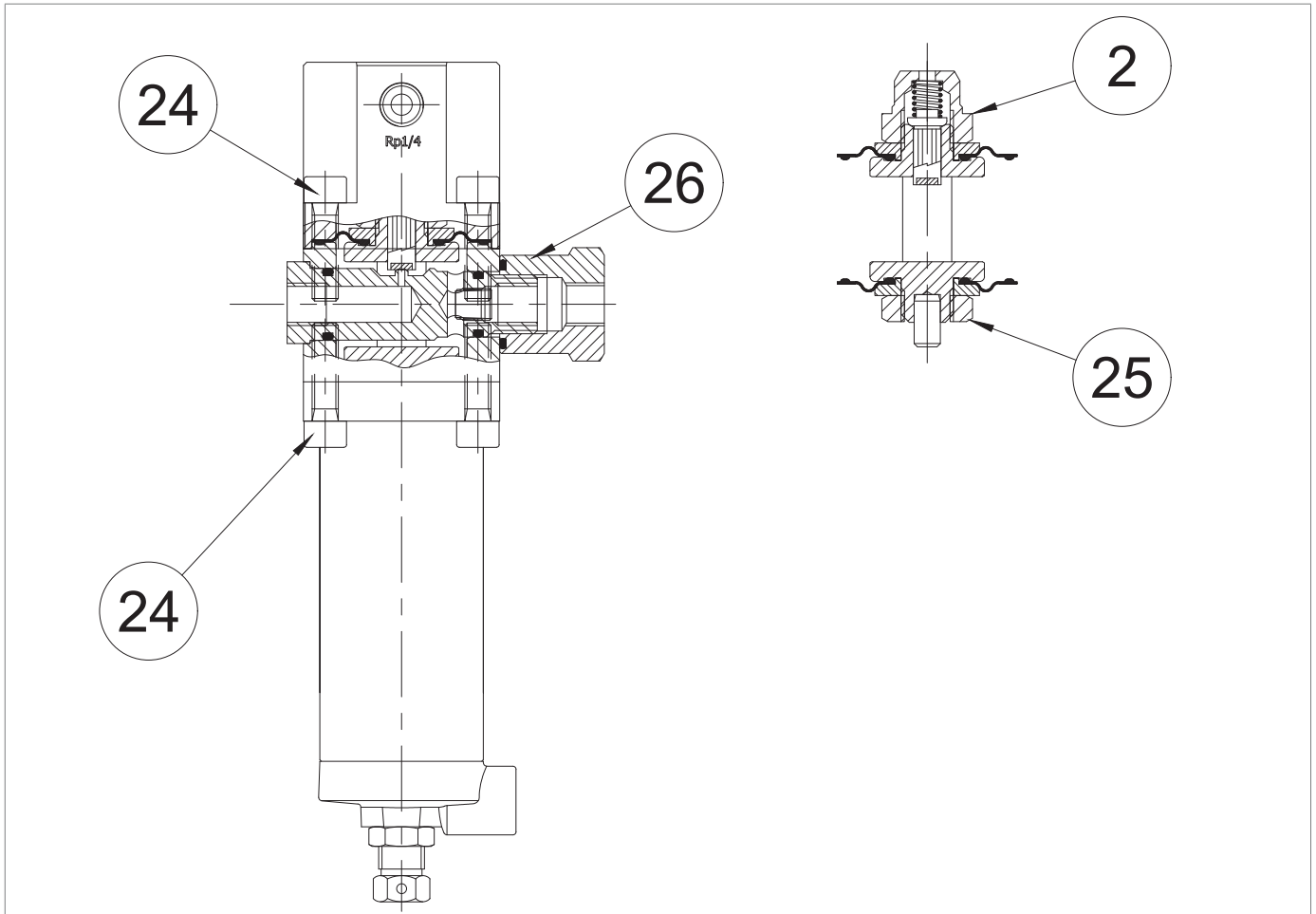

Fig. 9.50. Tightening torques for 204/A pilot

PILOTS 204/A			
Pos.	Description	Torque (Nm)	Torque (ft - lb)
2	Nut M16X1	25	18
24	Screw M8X30 UNI 5931	20	14
25	Nut M16X1.5	25	18
26	Nut M18X1.5	20	14

Tab. 9.114.

9.4.1.4 - PRE-REGULATOR TIGHTENING TORQUES

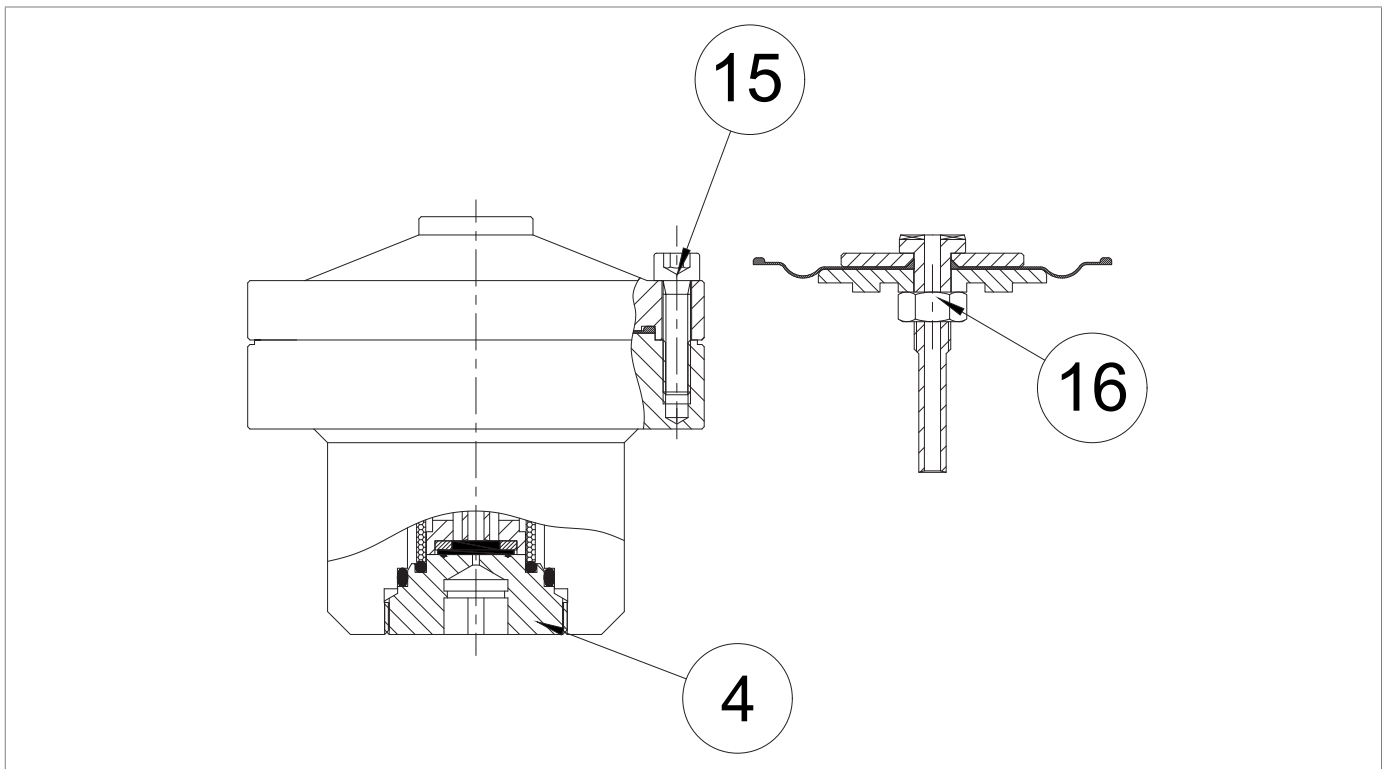

Fig. 9.51. Pre-regulator R31/A tightening torques

PRE-REGULATOR R31/A			
Pos.	Description	Torque (Nm)	Torque (ft - lb)
4	Cap	35	25
30	Nut M6x25 UNI 5931	8	5
32	Nut M8 UNI 5588	7	5

Tab. 9.115.

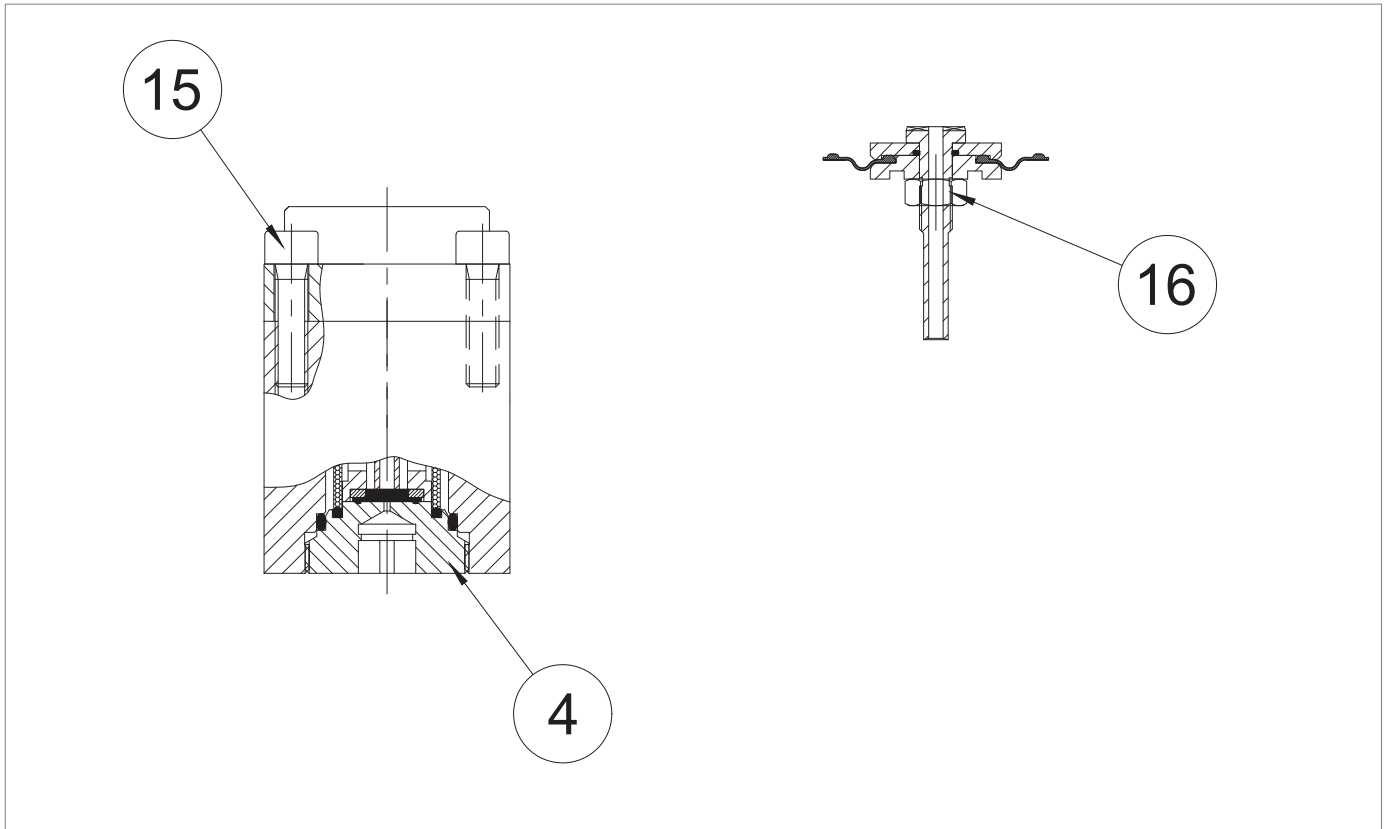

Fig. 9.52. Pre-regulator R14/A tightening torques

PRE-REGULATOR R14/A			
Pos.	Description	Torque (Nm)	Torque (ft - lb)
4	Cap	35	25
15	Nut M8x30 UNI 5931	20	14
16	Nut M8 UNI 5588	8	5

Tab. 9.116.

9.4.1.5 - TIGHTENING TORQUE SA SLAM-SHUT VALVE

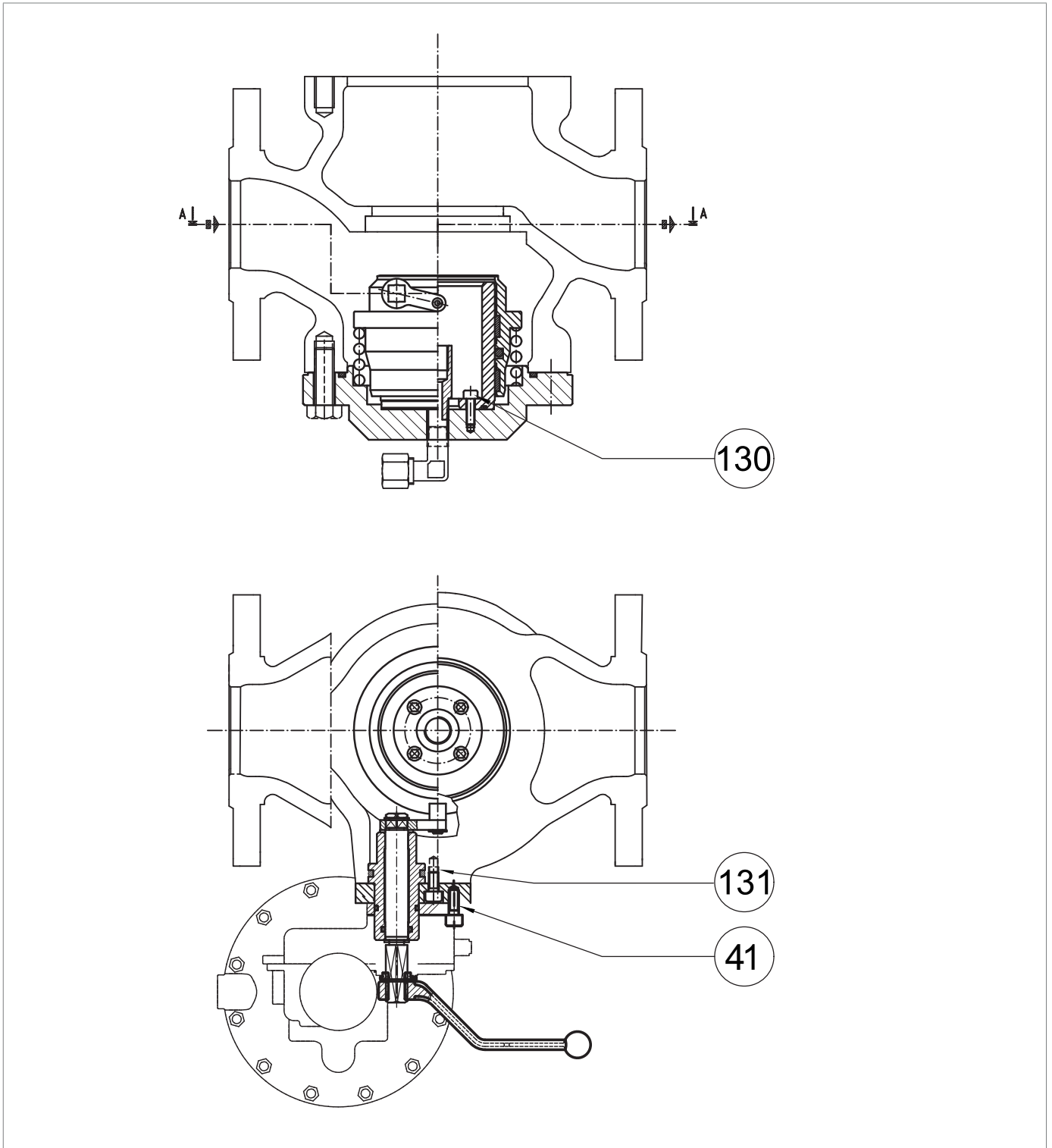

Fig. 9.53. SA slam-shut valve tightening torques

SA 1"

Pos.	Description	Torque (Nm)	Torque (ft - lb)
41	Screw M6X12 UNI 5931	10	7
130	Screw M5X16 UNI 5931	10	7
131	Screw M6X12 UNI 5931	10	7

Tab. 9.117.
SA 2"

Pos.	Description	Torque (Nm)	Torque (ft - lb)
41	Screw M6X12 UNI 5931	10	7
130	Screw M5X16 UNI 5931	10	7
131	Screw M6X12 UNI 5931	10	7

Tab. 9.118.
SA 2" ½

Pos.	Description	Torque (Nm)	Torque (ft - lb)
41	Screw M6X12 UNI 5931	10	7
130	Screw M5X16 UNI 5931	10	7
131	Screw M6X12 UNI 5931	10	7

Tab. 9.119.
SA 3"

Pos.	Description	Torque (Nm)	Torque (ft - lb)
41	Screw M6X12 UNI 5931	10	7
130	Screw M5X16 UNI 5931	10	7
131	Screw M6X12 UNI 5931	10	7

Tab. 9.120.
SA 4"

Pos.	Description	Torque (Nm)	Torque (ft - lb)
41	Screw M6X12 UNI 5931	10	7
130	Screw M5X16 UNI 5931	10	7
131	Screw M6X12 UNI 5931	10	7

Tab. 9.121.

9.4.1.6 - TIGHTENING TORQUE CONTROL PRESSURE SWITCH MOD. SA

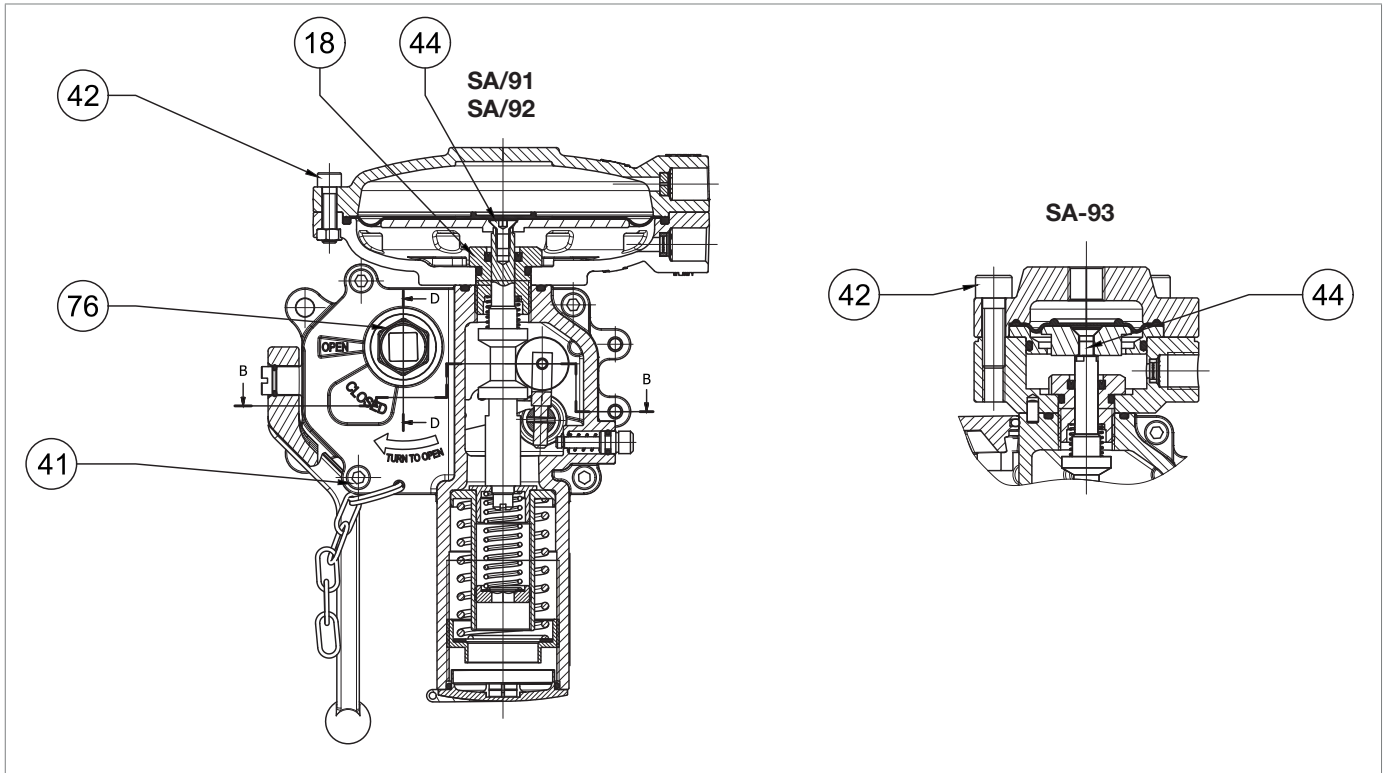

Fig. 9.54. Tightening torques for control pressure switch mod. SA

SA/91

Pos.	Description	Torque (Nm)	Torque (ft - lb)
18	Slam-shut device guide	45	33
41	Screw M5X10 UNI 5931	4	2
42	Screw M5X20 UNI 5931	5	3
44	Screw M5X10 UNI 5933	5	3

Tab. 9.122.
SA/92

Pos.	Description	Torque (Nm)	Torque (ft - lb)
18	Slam-shut device guide	45	33
41	Screw M5X10 UNI 5931	4	2
42	Screw M5X20 UNI 5931	5	3
44	Screw M5X10 UNI 5933	5	3

Tab. 9.123.
SA-93

Pos.	Description	Torque (Nm)	Torque (ft - lb)
18	Slam-shut device guide	45	33
41	Screw M5X10 UNI 5931	4	2
42	Screw M8X25 UNI 5931	16	11
44	Screw M5X16 UNI 5933	5	3

Tab. 9.124.

9.4.1.7 - SLAM-SHUT VALVE TIGHTENING TORQUES SB/82

Fig. 9.55. Slam-shut valve tightening torques SB/82 1"

SB/82 1"			
Pos.	Description	Torque (nm)	Torque (ft - lb)
5	Safety valve screw M10	40	29
11	Screw M6X12 UNI 5931	10	7
34	Screw M6X20 UNI 5931	10	7
35	Screw M6X20 UNI 5931	10	7
36	Screw M12X45 UNI 5931	80	59
37	Screw M10X25 UNI 5931	45	33
39	Screw M6X20 UNI 5931	10	7

Tab. 9.125.

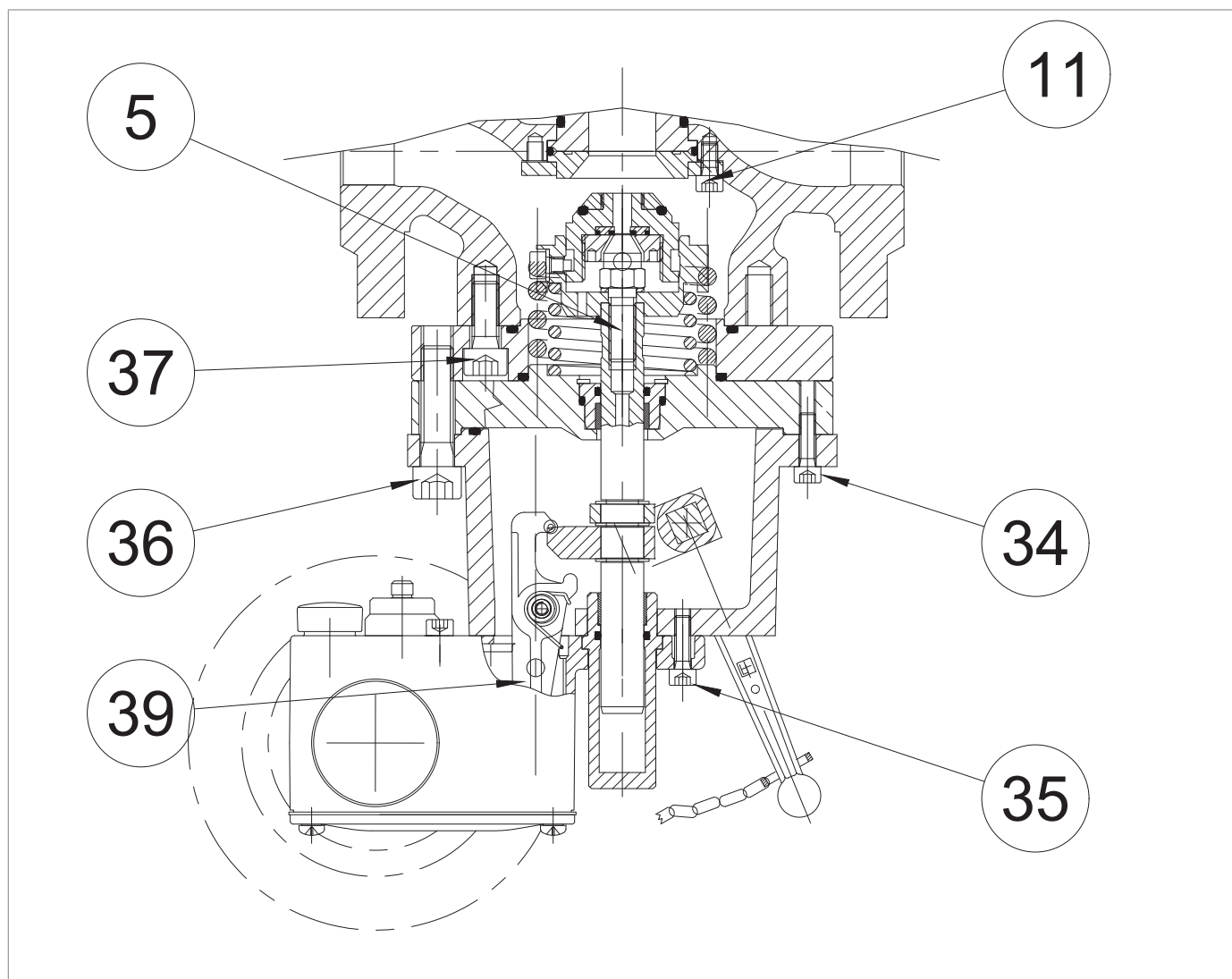
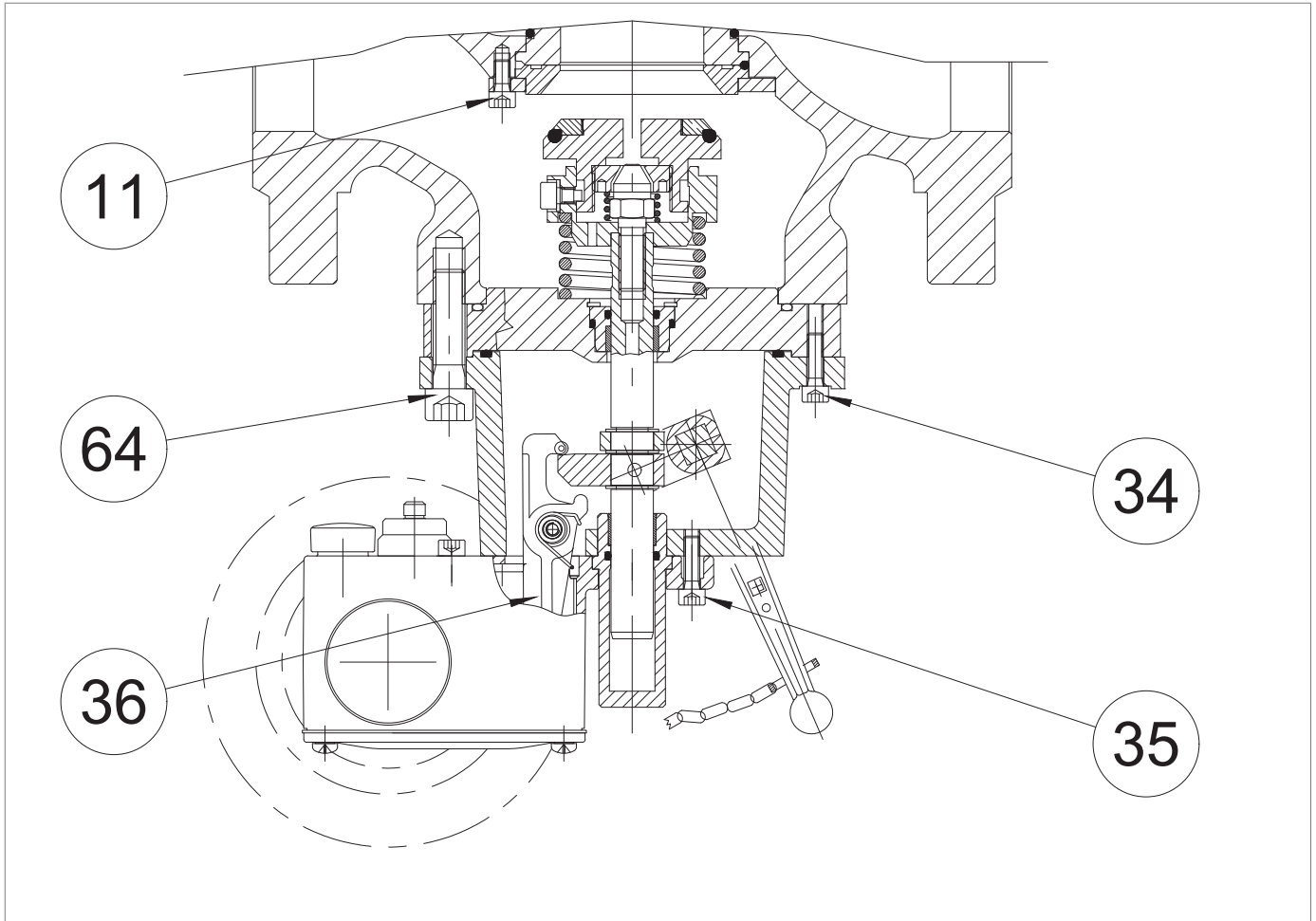

Fig. 9.56. Slam-shut valve tightening torques SB/82 2"

SB/82 2"			
Pos.	Description	Torque (nm)	Torque (ft - lb)
5	Safety valve screw M10	40	29
11	Screw M6X12 UNI 5931	10	5
34	Screw M6X20 UNI 5931	10	5
35	Screw M6X20 UNI 5931	10	5
36	Screw M6X20 UNI 5931	10	5
64	Screw M12X45 UNI 5931	80	59

Tab. 9.126.

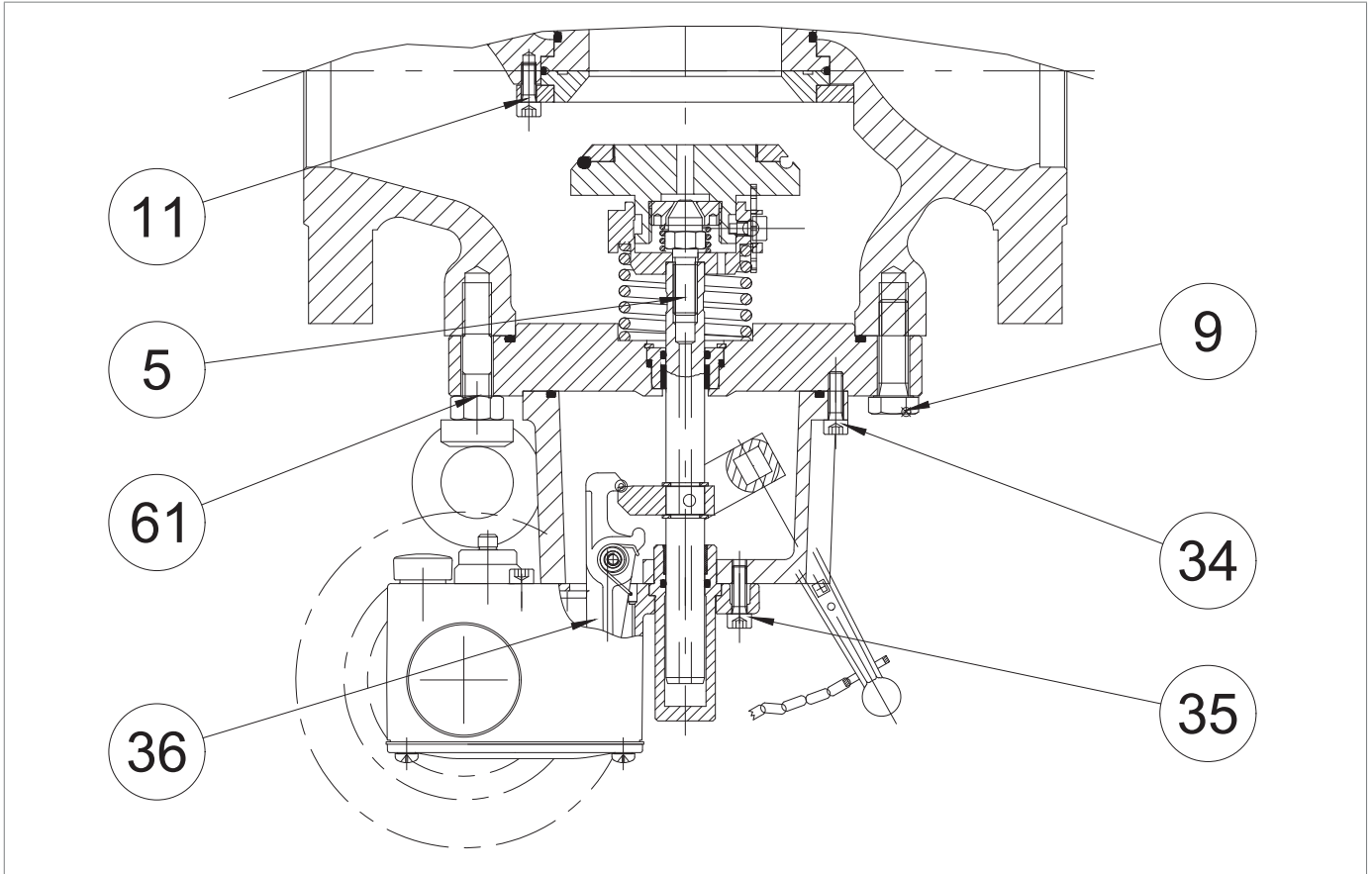

Fig. 9.57. Slam-shut valve tightening torques SB/82 2" 1/2 - 4"

SB/82 2 1/2			
Pos.	Description	Torque (nm)	Torque (ft - lb)
5	Safety valve screw M10	40	29
9	Screw M12X40 UNI 5739	80	59
11	Screw M6X12 UNI 5931	10	5
34	Screw M6X20 UNI 5931	10	5
35	Screw M6X20 UNI 5931	10	5
36	Screw M6X20 UNI 5931	10	5
61	Nut M12 UNI 5588	80	59

Tab. 9.127.

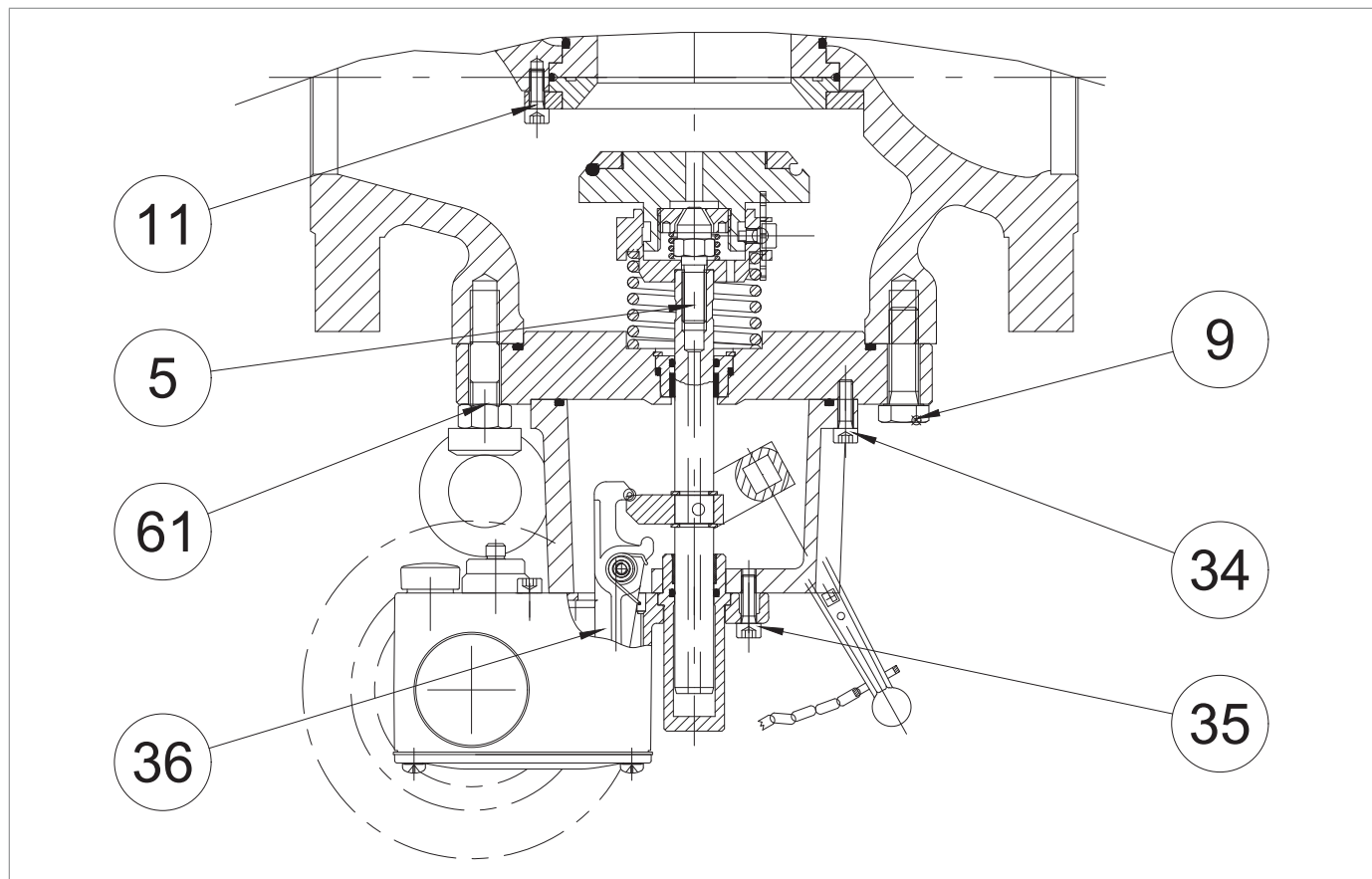

Fig. 9.58. Slam-shut valve tightening torques SB/82 2" ½ - 4"

SB/82 3"			
Pos.	Description	Torque (nm)	Torque (ft - lb)
5	Safety valve screw M10	40	29
9	Screw M12X40 UNI 5739	80	59
11	Screw M6X12 UNI 5931	10	5
34	Screw M6X20 UNI 5931	10	5
35	Screw M6X20 UNI 5931	10	5
36	Screw M6X20 UNI 5931	10	5
61	Nut M12 UNI 5588	80	59

Tab. 9.128.

SB/82 4"			
Pos.	Description	Torque (nm)	Torque (ft - lb)
5	Safety valve screw M10	40	29
9	Screw M16X50 UNI 5737	150	110
11	Screw M6X16 UNI 5931	10	5
33	Screw M6X14 UNI 5934	10	5
34	Screw M6X20 UNI 5931	10	5
35	Screw M6X14 UNI 5933	10	5
36	Screw M6X20 UNI 5931	10	5

Tab. 9.129.

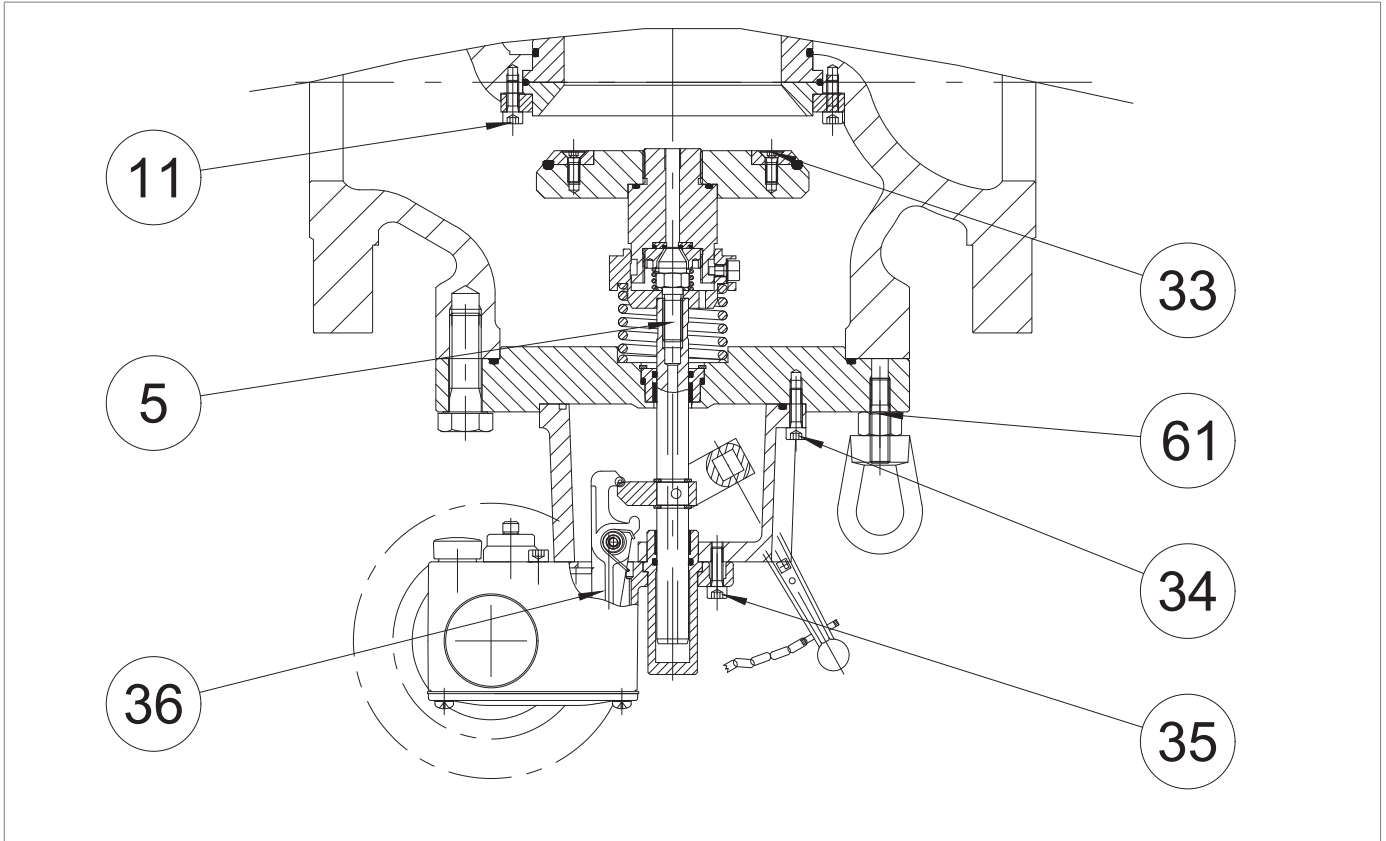

Fig. 9.59. Slam-shut valve tightening torques SB/82 6"-8"

SB/82 6"			
Pos.	Description	Torque (nm)	Torque (ft - lb)
5	Safety valve screw	40	29
10	Screw M14X50 UNI 5737	115	84
11	Screw M6X16 UNI 5931	10	5
33	Screw M6X10 UNI 5931	10	5
34	Screw M8X25 UNI 5931	20	14
35	Screw M6X40 UNI 5931	10	5
36	Screw M6X20 UNI 5931	10	5
61	Nut M14 UNI 5588	115	84

Tab. 9.130.

SB/82 8"			
Pos.	Description	Torque (nm)	Torque (ft - lb)
5	Safety valve screw M10	40	29
10	Screw M14X50 UNI 5737	115	84
11	Screw M6X16 UNI 5931	10	5
33	Screw M6X10 UNI 5931	10	5
34	Screw M8X25 UNI 5931	20	14
35	Screw M6X40 UNI 5931	10	5
36	Screw M6X20 UNI 5931	10	5
61	Nut M14 UNI 5588	115	84

Tab. 9.131.

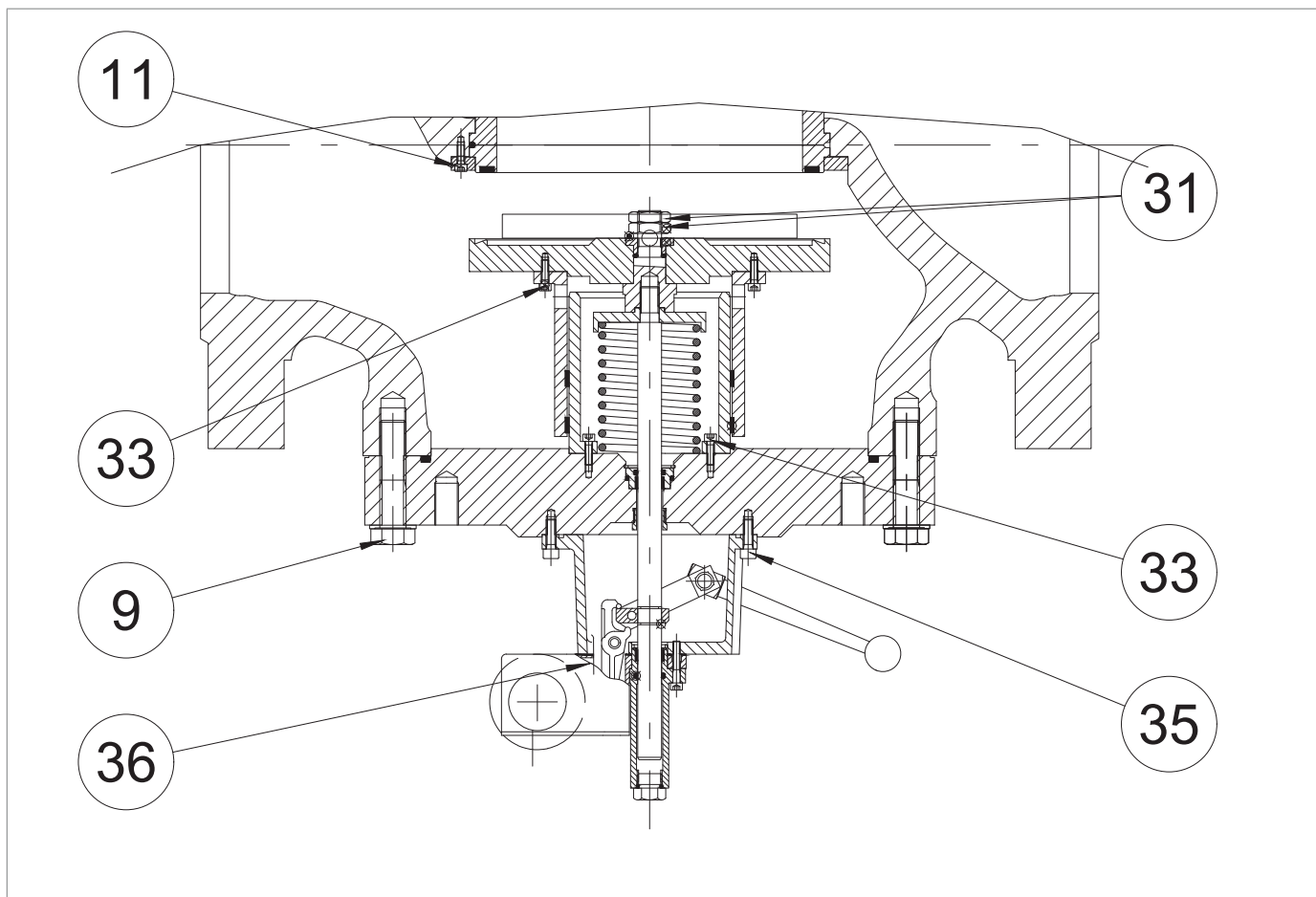

Fig. 9.60. Slam-shut valve tightening torques SB/82 10"

SB/82 10"			
Pos.	Description	Torque (nm)	Torque (ft - lb)
9	Screw M16X90 UNI 5737	150	110
11	Screw M6X16 UNI 5931	10	5
31	Nut M20 UNI 5589	250	184
33	Screw M6X20 UNI 5931	10	5
35	Screw M8X25 UNI 5931	20	14
36	Screw M6X35 UNI 5931	10	5
137	Screw M6X20 UNI 5931	10	5

Tab. 9.132.

9.4.1.8 - TIGHTENING TORQUES OF THE HB/97 SLAM-SHUT VALVE WITH LINE OFF 2.0

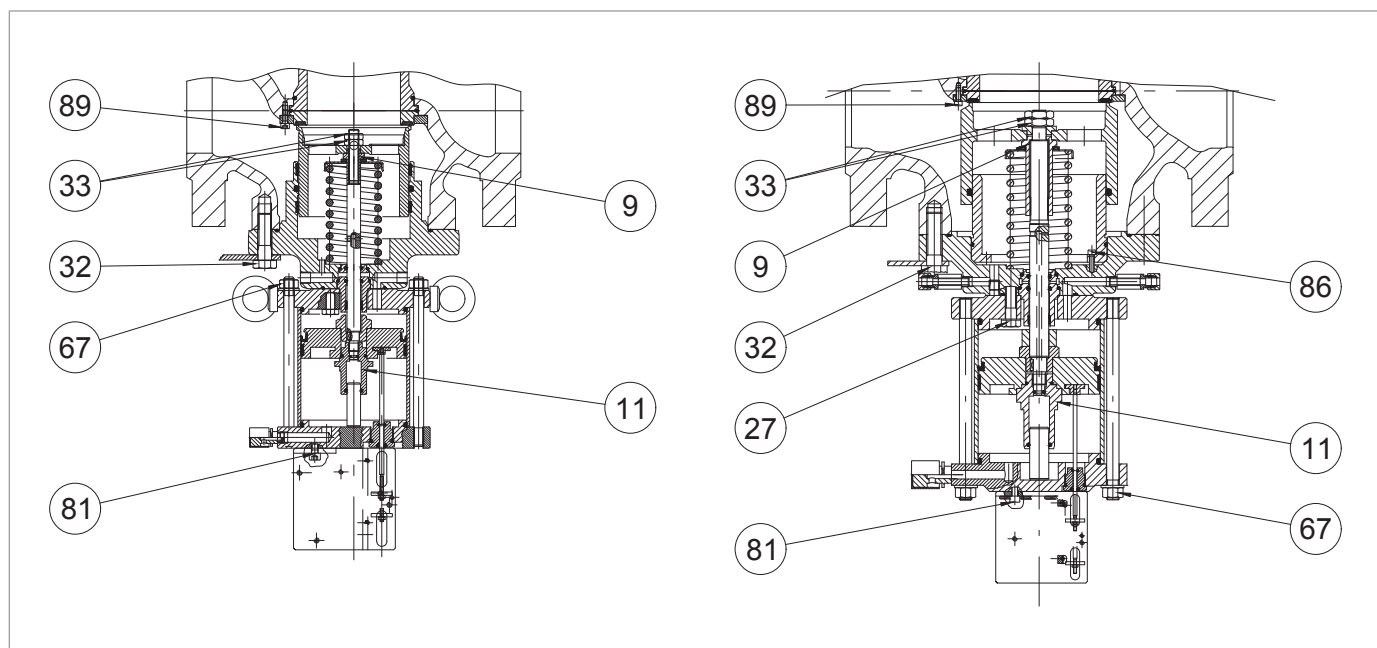

Fig. 9.61. Slam-shut valve tightening torques HB/97

HB/97 4"			
Pos.	Description	Torque (nm)	Torque (ft - lb)
9	Locking nut M12X1.25	35	25
11	M12X1.25 balancing piston guide	35	25
27	Screw M10X40 UNI 5737	45	33
33	Nut M12X1.25 UNI 5589	35	25
67	Nut M12 UNI 5588	80	59
81	Screw M8X16 UNI 5931	20	14
87	Screw M6X16 UNI 5931	10	7

Tab. 9.133.

HB/97 6"			
Pos.	Description	Torque (nm)	Torque (ft - lb)
9	Locking nut M24X1.5	110	81
11	M18X1.5 balancing piston guide	110	81
27	Screw M14X50 UNI 5737	115	84
33	Nut M18X1.5 UNI 5589	110	81
67	Nut M16 UNI 5588	200	147
81	Screw M8X20 UNI 5931	20	14
86	Screw M6X25 UNI 5931	10	7
89	Screw M6X16 UNI 5931	10	7

Tab. 9.134.

HB/97 8"			
----------	--	--	--

Pos.	Description	Torque (nm)	Torque (ft - lb)
9	Locking nut M24X1.5	110	81
11	M18X1.5 balancing piston guide	110	81
27	Screw M14X50 UNI 5737	115	84
33	Nut M18X1.5 UNI 5589	110	81
67	Nut M16 UNI 5588	200	147
81	Screw M8X20 UNI 5931	20	14
86	Screw M6X25 UNI 5931	10	7
89	Screw M6X16 UNI 5931	10	7

Tab. 9.135.

HB/97 10"			
Pos.	Description	Torque (nm)	Torque (ft - lb)
9	Locking nut M30X1.5	150	110
11	M22X1.5 balancing piston guide	150	110
27	Screw M20X70 UNI 5931	250	184
33	Nut M20X1.5 UNI 5589	150	110
67	Nut M16 UNI 5588	200	147
81	Screw M8X20 UNI 5931	20	14
86	Screw M6X25 UNI 5931	10	7
89	Screw M6X16 UNI 5931	10	7

Tab. 9.136.

9.4.1.9 - TIGHTENING TORQUES PRESSURE SWITCHES MOD. 100

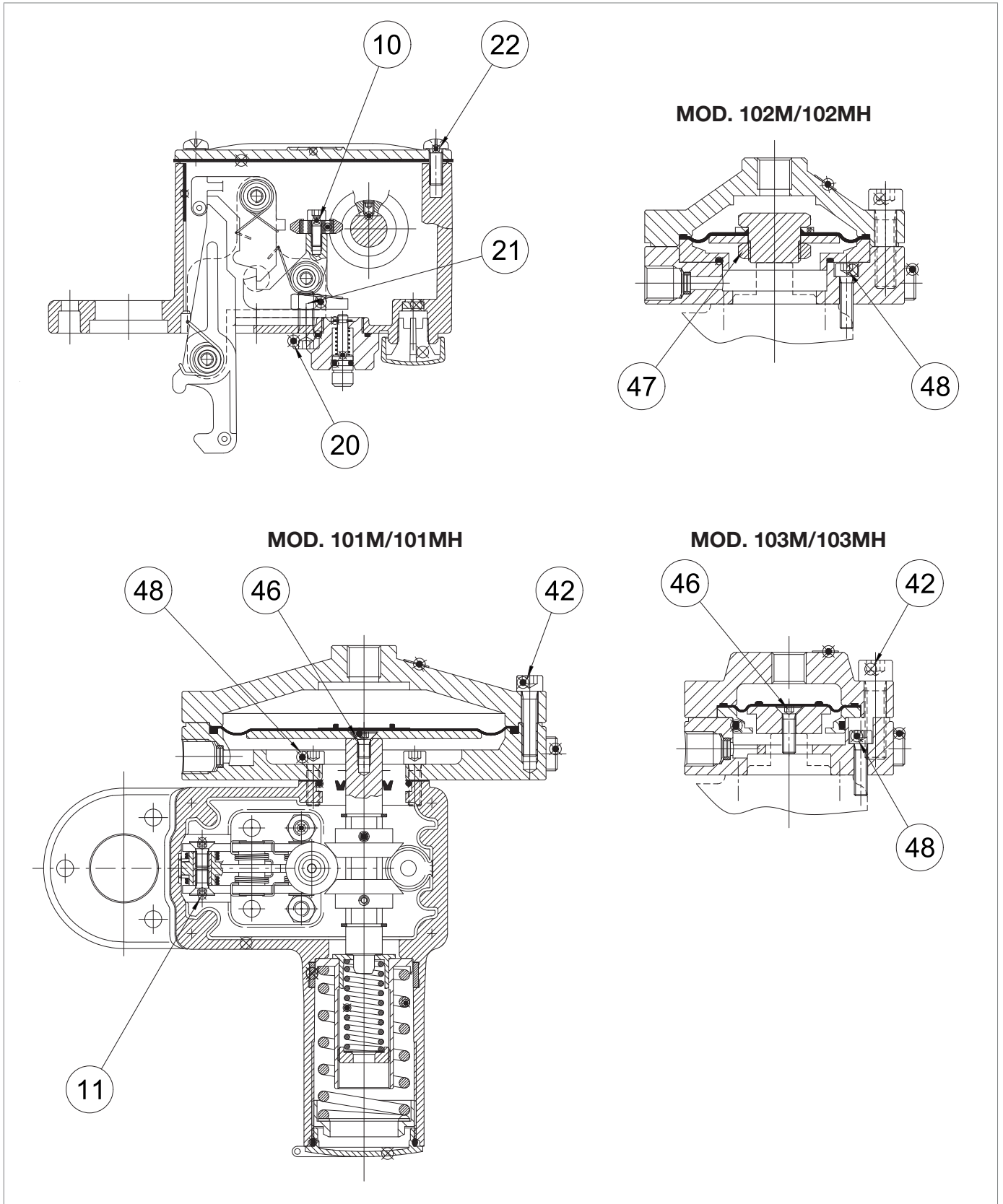

Fig. 9.62. Tightening torques pressure switches mod.100

MOD. 101M/101MH

Pos.	Description	Torque (nm)	Torque (ft - lb)
10	Screw M4X10 UNI 5931	3	2
11	Screw M5X10 UNI 5933	5	3
20	Screw M6X16 UNI 5931	10	7
21	Nut M6 UNI 5588	10	7
22	Screw M5X15 UNI 8112	5	3
42	Screw M6X25 UNI 5931	7	5
46	Screw M5X10 UNI 5933	5	3
48	Screw M5X16 UNI 5931	5	3

Tab. 9.137.
MOD. 102M/102MH

Pos.	Description	Torque (nm)	Torque (ft - lb)
10	Screw M4X10 UNI 5931	3	2
11	Screw M5X10 UNI 5933	5	3
20	Screw M6X16 UNI 5931	10	7
21	Nut M6 UNI 5588	10	7
22	Screw M5X15 UNI 8112	5	3
42	Screw M6X25 UNI 5931	16	11
47	Nut M20X1	8	5
48	Screw M5X16 UNI 5931	5	3

Tab. 9.138.
MOD. 103M/103MH

Pos.	Description	Torque (nm)	Torque (ft - lb)
10	Screw M4X10 UNI 5931	3	2
11	Screw M5X10 UNI 5933	5	3
20	Screw M6X16 UNI 5931	10	7
21	Nut M6 UNI 5588	10	7
22	Screw M5X15 UNI 8112	5	3
42	Screw M8X30 UNI 5931	16	11
46	Screw M5X18 UNI 5931	8	5
48	Screw M5X20 UNI 5931	5	3

Tab. 9.139.

9.4.1.10 - TIGHTENING TORQUES FOR HP2/2 BYPASS DEVICE

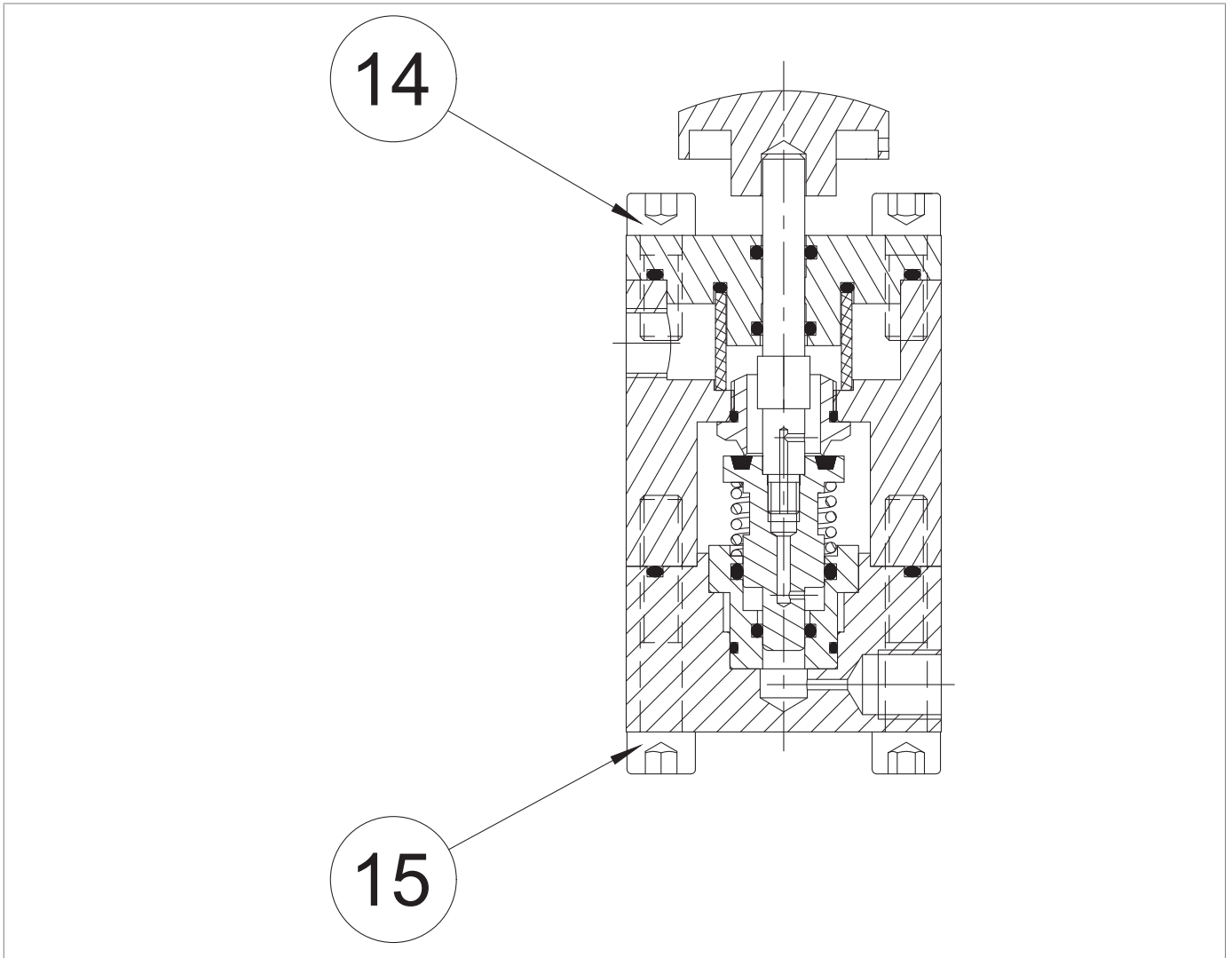

Fig. 9.63. Tightening torques for HP2/2 bypass device

HP2/2			
Pos.	Description	Torque (Nm)	Torque (ft - lb)
14	Screw M8X20 UNI 5931	16	11
15	Screw M8X45 UNI 5931	16	11

Tab. 9.140.

9.4.1.11 - TIGHTENING TORQUES FOR THROTTLE VALVE AR100

Fig. 9.64. Tightening torques for throttle valve AR100

LAMINATION VALVE AR100			
Pos.	Description	Torque (Nm)	Torque (ft - lb)
2	Cap M20X1.5	20	14
4	Screw M8	4	2

Tab. 9.141.

9.4.1.12 - TIGHTENING TORQUES FOR R44/SS REGULATOR

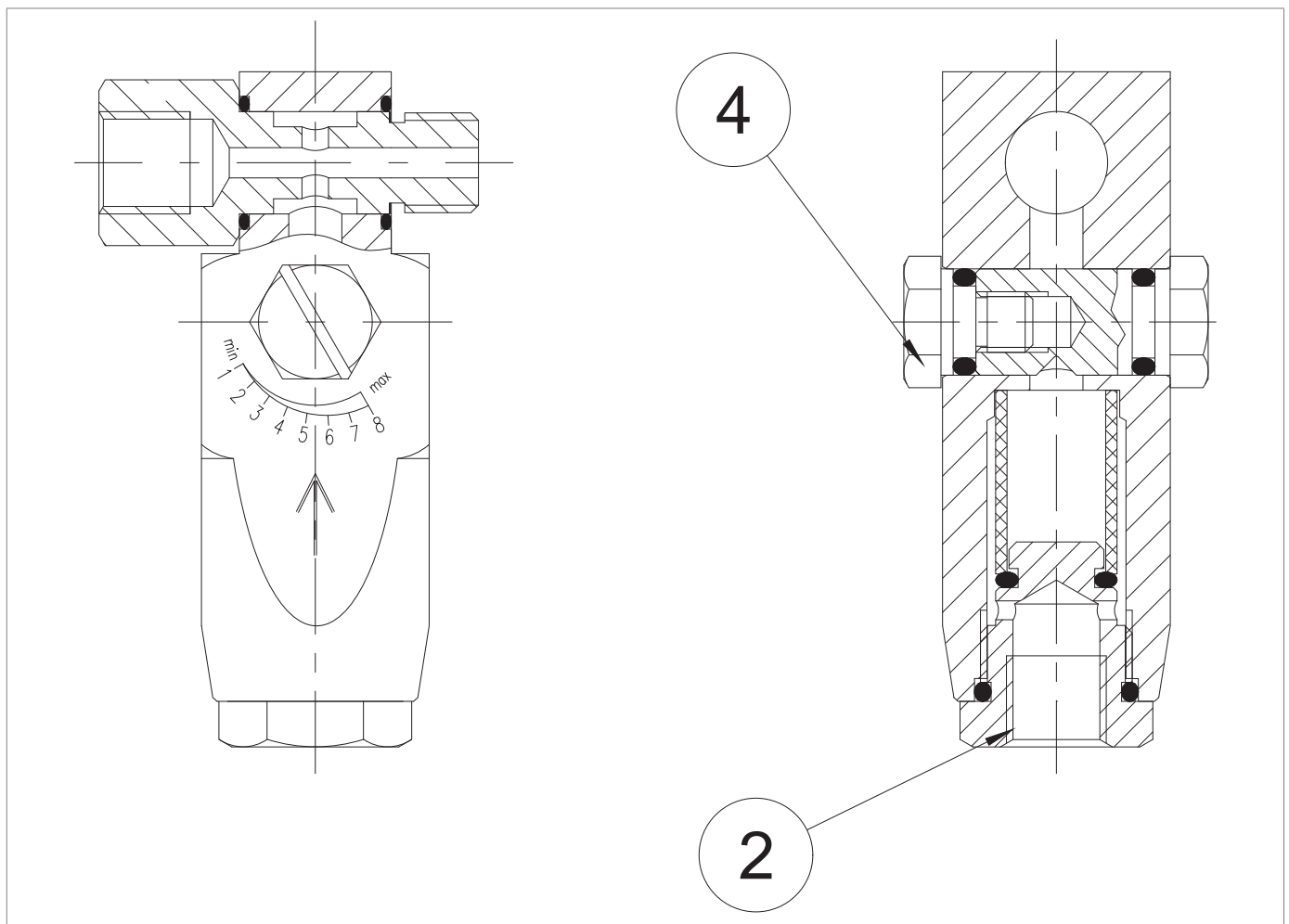
Fig. 9.65. Tightening torques for R44/SS regulator

R44/SS			
Pos.	Description	Torque (Nm)	Torque (ft - lb)
2	Nut M16X1	25	18
24	Screw M8X10 UNI 5931	16	11
24.1	Screw M8X70 UNI 5931	16	11
25	Nut M16X1.5	25	18
26	Nut M18X1.5	20	14

Tab. 9.142.

9.4.2 - REPLACING ELEMENTS SUBJECT TO WEAR AND ABRASION

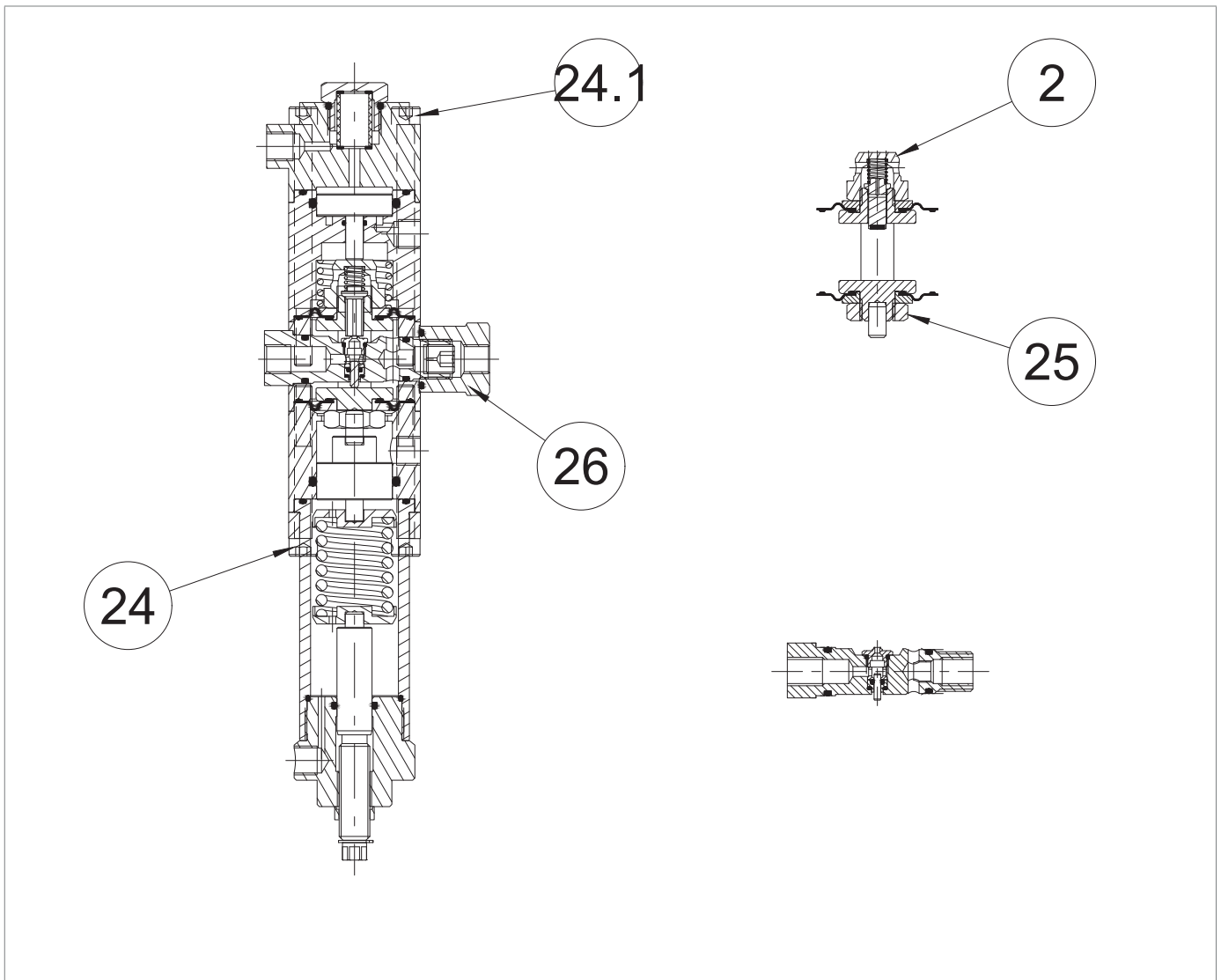
9.4.2.1 - INITIAL OPERATIONS

WARNING!

Before any intervention, it is necessary:

- to ensure that the line on which the equipment is installed is shut off upstream and downstream;
 - to operate the slam shut valve in manual mode by pressing the release button (Pos. 10 - Figure 4.14.).
- Next, check that the pressure indicated by the pressure gauge installed on the LINE OFF 2.0 device (Pos. 7.3 - Figure 8.41.) is 0 bar, ensuring complete depressurisation of the line.

ATTENTION!

During assembly, make sure to tighten the screws as per the tables (tightening torques), according to the size for which maintenance is being carried out.

Proceed as in Tab. 9.143:

Step	Action
1	Unscrew the conical seal fittings to disconnect all power outlets and sensing lines for the pilot and regulator.
2	Loosen the nut securing the pilot support bracket to the regulator.
3	Remove the 200/A series pilot installed with the R31/A pre-regulator from the regulator.
	<div style="border: 1px solid black; padding: 5px;">  NOTICE! For replacement and pilot disconnection procedures for the 200/A series and the R31/A pre-regulator, please refer to paragraph 9.4.6. </div>

Tab. 9.143.

9.4.2.2 - CROSS DIAGRAM FOR TIGHTENING SCREWS

To tighten the screws, when required by the maintenance procedure, refer to the following diagram:

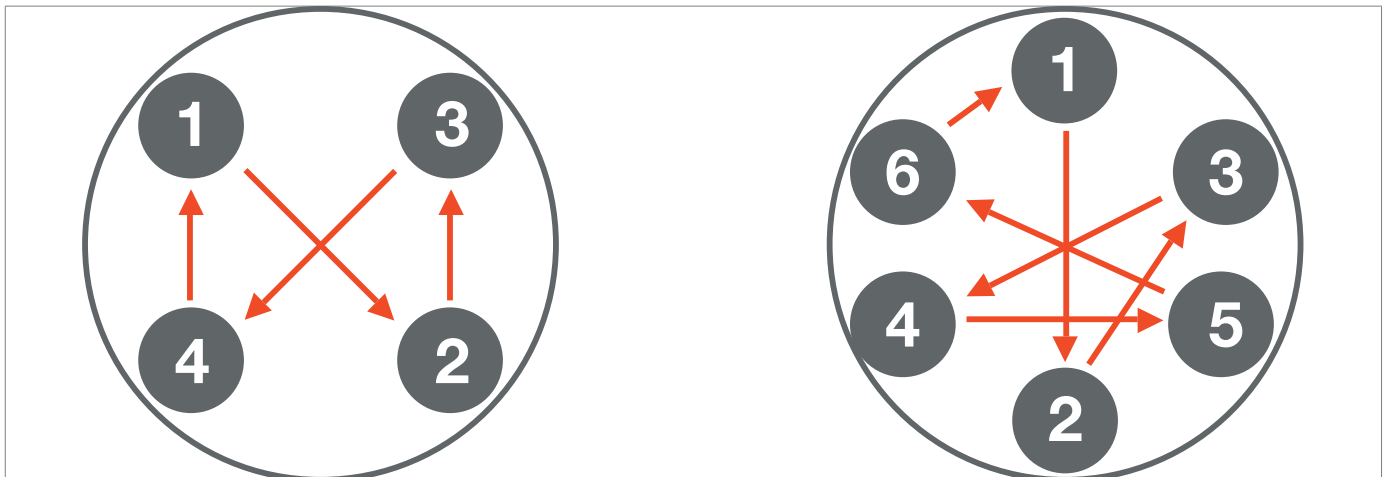

Fig. 9.66. Cross diagram

9.4.3 - REGULATOR MAINTENANCE PROCEDURE REVAL 182

9.4.3.1 - REGULATOR REVAL 182 1" ÷ 2"

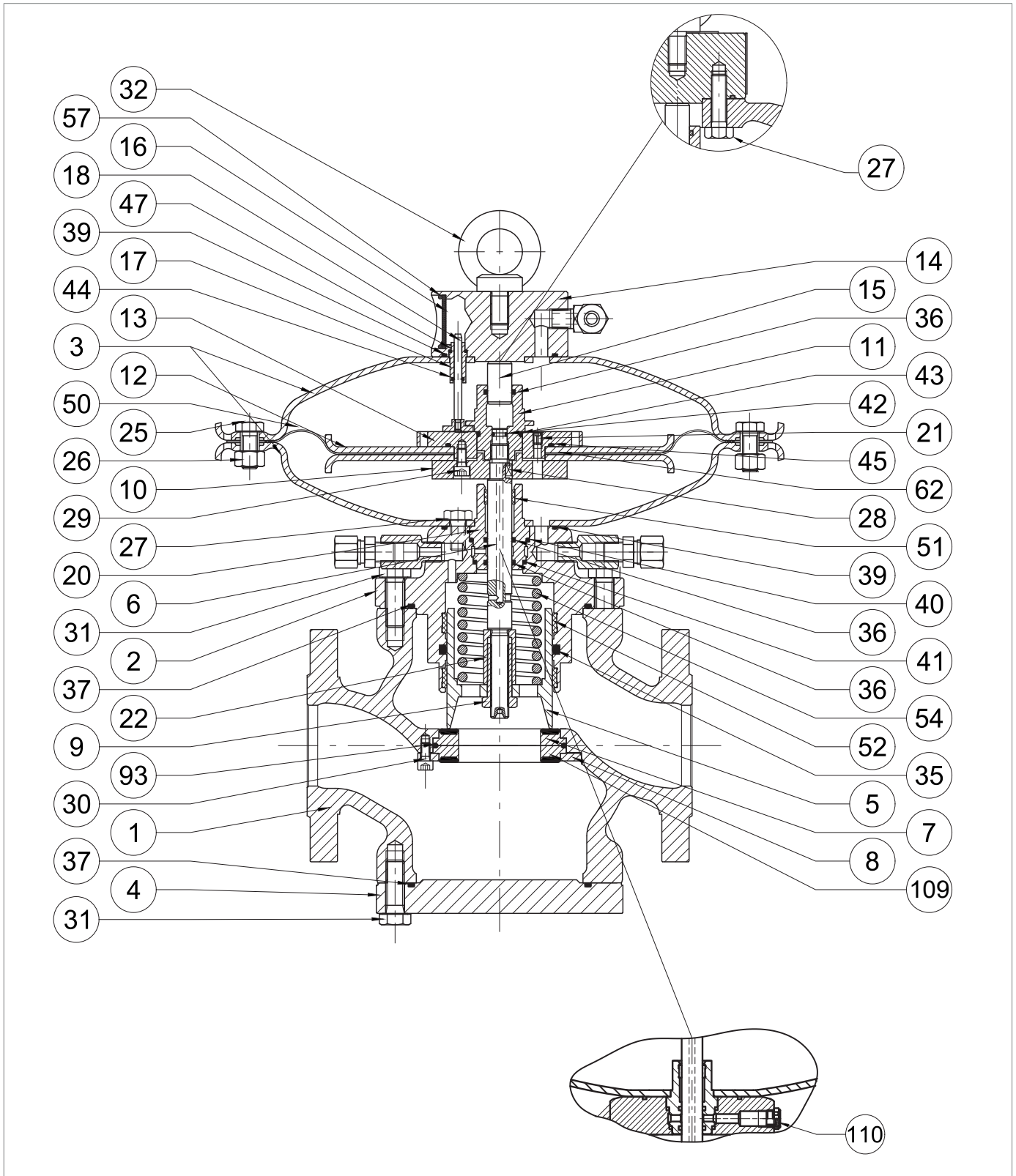

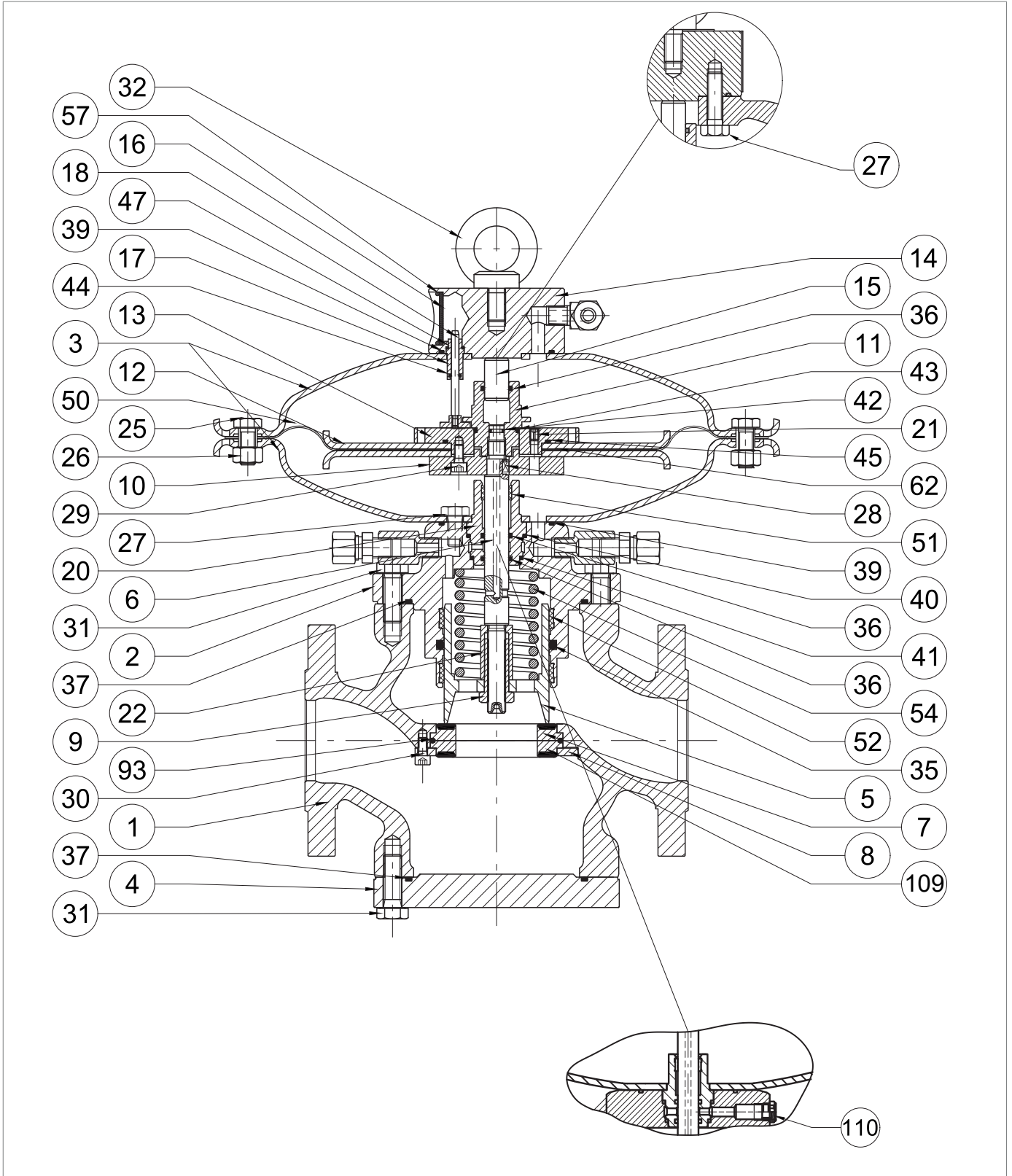

Fig. 9.67. Regulator REVAL 182 1" ÷ 2"

Step	Action
1	<p>Unscrew and remove the screws on the upper part (31) which secure the control head to the regulator body (1).</p> <div style="border: 1px solid black; padding: 5px;">  NOTICE! Support the head assembly during this step to avoid falls. </div>
2	<p>Remove the control head and place it on its side on a plane with an impact-resistant surface.</p> <div style="border: 1px solid black; padding: 5px;">  NOTICE! Take care not to damage the plug profile (5). </div>
3	<p>Remove the O-ring (37) from the plug guide (2) and replace it, lubricating it with synthetic grease.</p> <div style="border: 1px solid black; padding: 5px;">  NOTICE! Before inserting the replacement O-ring, clean the retaining slots with a cleaning solution. </div>
4	<p>Unscrew the lock nut (9).</p> <div style="border: 1px solid black; padding: 5px;">  NOTICE! Take care not to damage the plug profile (5). </div>
5	Remove the plug (5) and place it on a table with an impact-resistant surface.
6	Remove the spring (54) together with the spacer (22).
7	<p>Remove and replace the I/DWR rings (52) from the plug guide (2).</p> <div style="border: 1px solid black; padding: 5px;">  NOTICE! Before inserting the replacement I/DWR rings, clean the retaining slots with a cleaning solution. </div>
8	<p>Remove the O-ring (35) from the plug guide (2) and replace it, lubricating it with synthetic grease.</p> <div style="border: 1px solid black; padding: 5px;">  NOTICE! Before inserting the replacement O-ring, clean the retaining slots with a cleaning solution. </div>
9	Clean the plug (5) and the plug guide (2) lubricating with silicone grease.
10	Unscrew and remove the nuts (26) together with the screws (25).
11	Remove the upper lid (3).
12	Remove the indicator rod (18) from the rod guide (17).
13	Unscrew and remove the top screws (27) from the top cover (3).
14	Separate the upper cover (3) from the eyebolt flange (14).
15	Take out the rod guide (17).
16	<p>Remove the O-rings (39, 47) from the eyebolt flange (14) and replace them, lubricating them with synthetic grease.</p> <div style="border: 1px solid black; padding: 5px;">  NOTICE! Before inserting the replacement O-rings, clean the retaining slots with a cleaning solution. </div>
17	<p>Remove the O-ring (44) from the rod guide (17) and replace it, lubricating it with synthetic grease.</p> <div style="border: 1px solid black; padding: 5px;">  NOTICE! Before inserting the replacement O-ring, clean the retaining slots with a cleaning solution. </div>



Regulator REVAL 182 1" ÷ 2"

Step	Action
18	Place the rod guide (17) in the eyebolt flange (14).
19	Assemble the eyebolt flange (14) with the upper lid (3).
20	<p>Insert and fix the screws of the upper section (27) according to the following tightening torque:</p> <ul style="list-style-type: none"> • 1": Tab. 9.90 • 2": Tab. 9.91 <p>NOTICE! Tighten the screws according to the cross diagram in paragraph 9.4.2.2.</p>
21	Insert the indicator rod (18) into the rod guide (17).
22	<p>Unscrew and remove the balancing stem guide (11).</p> <p>NOTICE! Hold the diaphragm assembly in place by positioning the spanner in the holes in the upper diaphragm support (13).</p>
23	Remove the balancing piston (15) from the balancing stem guide (11).
24	<p>Remove and replace the O-rings (36, 43) from the balancing stem guide (11), lubricating them with synthetic grease.</p> <p>NOTICE! Before inserting the replacement O-rings, clean the retaining slots with a cleaning solution.</p>
25	Position the balancing piston (15) in the balancing stem guide (11).
26	Take out the diaphragm unit (10, 12, 13, 21, 29, 45, 50, 62)
27	Undo and remove the screws (29) from the lower diaphragm support (10).
28	Remove diaphragm support (10) and upper diaphragm protection disc (12).
29	Remove the diaphragm (50) together with the oil seal (62).
30	Remove the lower diaphragm protection disc (12) from the upper diaphragm holder (13).
31	<p>Remove and replace the O-ring (45) from the upper diaphragm support (13), lubricating it with synthetic grease.</p> <p>NOTICE! Before inserting the replacement O-ring, clean the retaining slots with a cleaning solution.</p>
32	<p>Place the upper diaphragm protection disc (12) in the upper diaphragm holder (13).</p> <p>NOTICE! Check that the hole on the nozzle (21) is free from dirt or foreign bodies.</p>
33	Position the oil seal (62).
34	<p>Position the diaphragm (50).</p> <p>NOTICE! The concave part of the diaphragm must face the drive chamber (pos. B, fig. 4.2).</p>

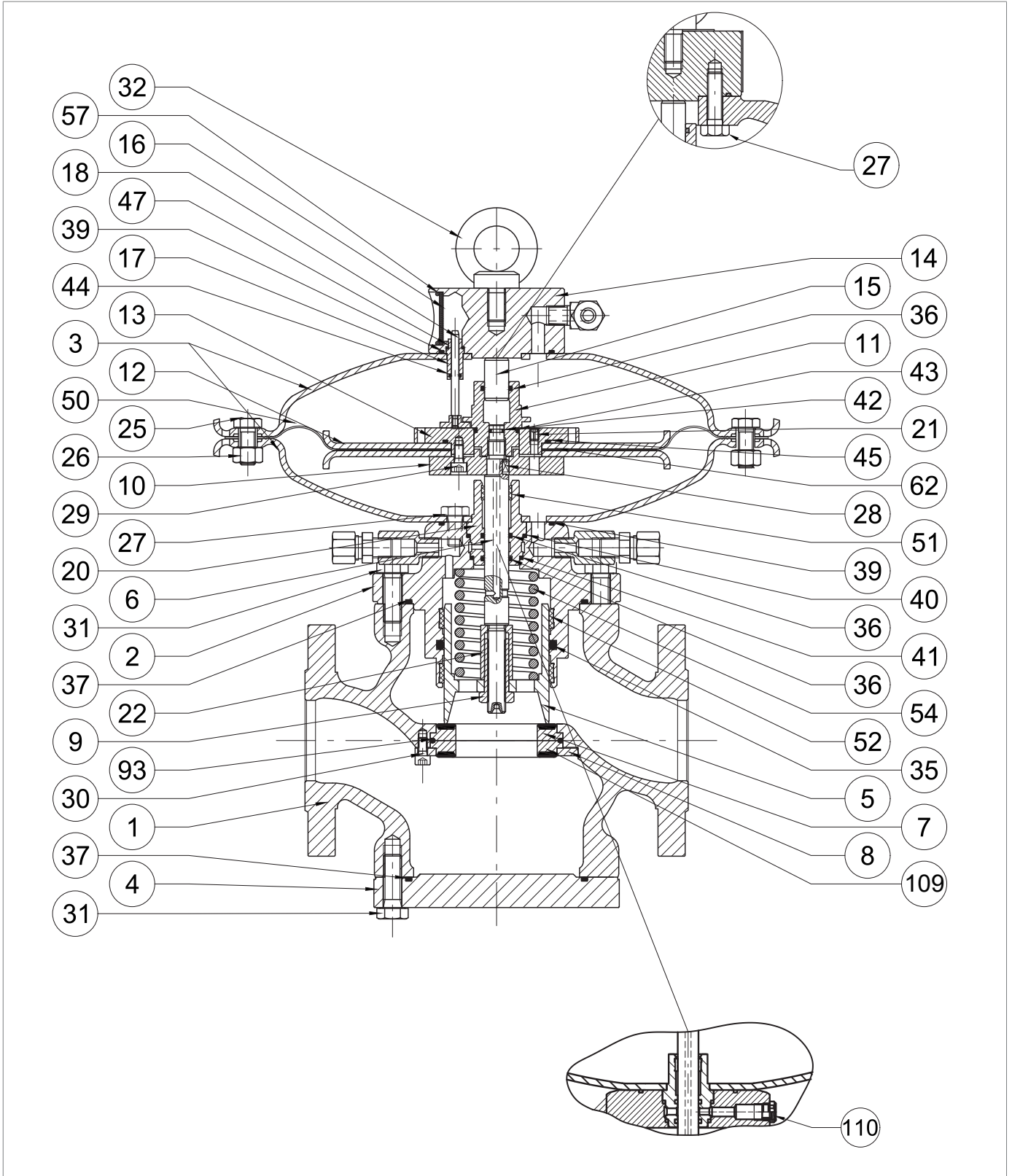

Regulator REVAL 182 1" ÷ 2"

Step	Action
35	<p>Put the diaphragm protection disc (12) and the lower diaphragm support (10) in place.</p> <div style="border: 1px solid black; padding: 5px;"> <p>! NOTICE!</p> <p>Check that the nozzle hole on the upper diaphragm support (13) is aligned with the hole on the lower diaphragm support (10).</p> </div>
36	<p>Apply thread locking glue to insert and fix the screws (29) according to the following tightening torque:</p> <ul style="list-style-type: none"> • 1": Tab. 9.90 • 2": Tab. 9.91 <div style="border: 1px solid black; padding: 5px;"> <p>! NOTICE!</p> <p>Tighten the screws according to the cross diagram in paragraph 9.4.2.2.</p> </div>
37	Unscrew and remove the lower part screws (27) from the lower cover (3).
38	Remove the lower cover (3).
39	<p>Remove the O-ring (39) from the plug guide (2) and replace it, lubricating it with synthetic grease.</p> <div style="border: 1px solid black; padding: 5px;"> <p>! NOTICE!</p> <p>Before inserting the replacement O-ring, clean the retaining slots with a cleaning solution.</p> </div>
40	Remove the stem guide (20), the stem (6) and the key (28).
41	<p>Remove and replace the I/DWR rings (51) from the stem guide (20).</p> <div style="border: 1px solid black; padding: 5px;"> <p>! NOTICE!</p> <p>Before inserting the replacement I/DWR ring, clean the retaining slots with a cleaning solution.</p> </div>
42	<p>Remove the O-rings (36) from the stem guide (20) and replace them, lubricating them with synthetic grease.</p> <div style="border: 1px solid black; padding: 5px;"> <p>! NOTICE!</p> <p>Before inserting the replacement O-rings, clean the retaining slots with a cleaning solution.</p> </div>
43	<p>Remove the O-rings (40, 41) from the stem guide (20) and replace them, lubricating them with synthetic grease.</p> <div style="border: 1px solid black; padding: 5px;"> <p>! NOTICE!</p> <p>Before inserting the replacement O-rings, clean the retaining slots with a cleaning solution.</p> </div>
44	<p>Remove the O-ring (42) from the stem (6) and replace it, lubricating it with synthetic grease.</p> <div style="border: 1px solid black; padding: 5px;"> <p>! NOTICE!</p> <p>Before inserting the replacement O-ring, clean the retaining slots with a cleaning solution.</p> </div>
45	<p>Remove the stem guide (20), the stem (6) and the key (28).</p> <div style="border: 1px solid black; padding: 5px;"> <p>! NOTICE!</p> <ul style="list-style-type: none"> • Lubricate the stem surface with silicone grease • The key (28) must be in the correct position in the stem (6) </div>

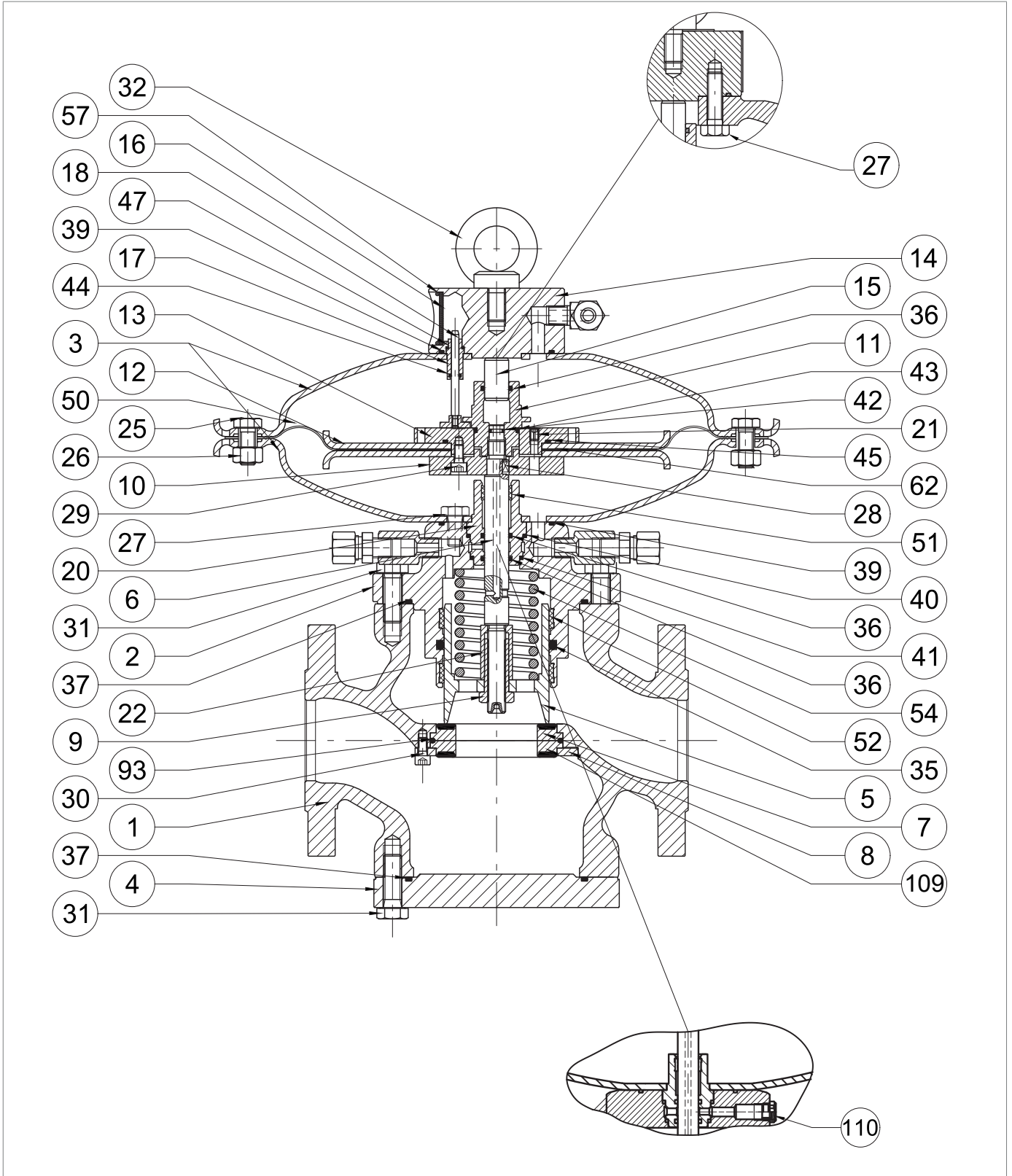

Regulator REVAL 182 1" ÷ 2"

Step	Action
46	Place the lower cover (3) on the plug guide (2). NOTICE! The hole for the passage of the loading pressure must match the similar one on the plug guide.
47	Insert and fasten the screws of the lower part (27) in the lower cover (3) according to the tightening torque: • 1": Tab. 9.90 • 2": Tab. 9.91 NOTICE! Tighten the screws according to the cross diagram in paragraph 9.4.2.2.
48	Put the diaphragm unit in place (10, 12, 13, 21, 29, 45, 50, 62).
49	Insert and secure the balancing stem guide (11) according to the tightening torque: • 1": Tab. 9.90 • 2": Tab. 9.91 NOTICE! During this phase: • hold the diaphragm assembly in place by positioning the spanner in the holes in the upper diaphragm support (13) • the holes in the diaphragm must match the holes in the lower cover (3)
50	Position the upper cover (3), taking care to position the indicator stem (18) in the space between the upper diaphragm support (13) and the balance stem guide (11). NOTICE! • The indicator rod (18) must not obstruct the pouring hole (21) on the upper diaphragm support (13) • The flange travel indicator must be visible and perpendicular to the gas flow
51	Insert and fasten the screws (25) with the nuts (26) according to the tightening torque: • 1": Tab. 9.90 • 2": Tab. 9.91
52	Turn the control head upside down.
53	Put the spacer (22) and the spring (54) in place. NOTICE! Fit the spacer (22) so that the stop with the narrower hole rests on the surface of the stem (6).
54	Insert the plug (5).
55	Insert the locking nut (9) according to the tightening torque: • 1": Tab. 9.90 • 2": Tab. 9.91 NOTICE! Before fixing the lock nut (9), check that the spring (54) is well seated in the appropriate centring stop on the plug guide (2).
56	Undo and remove the screws of the lower section (31).
57	Remove the blind flange (4). NOTICE! During this step, support the blind flange (4).

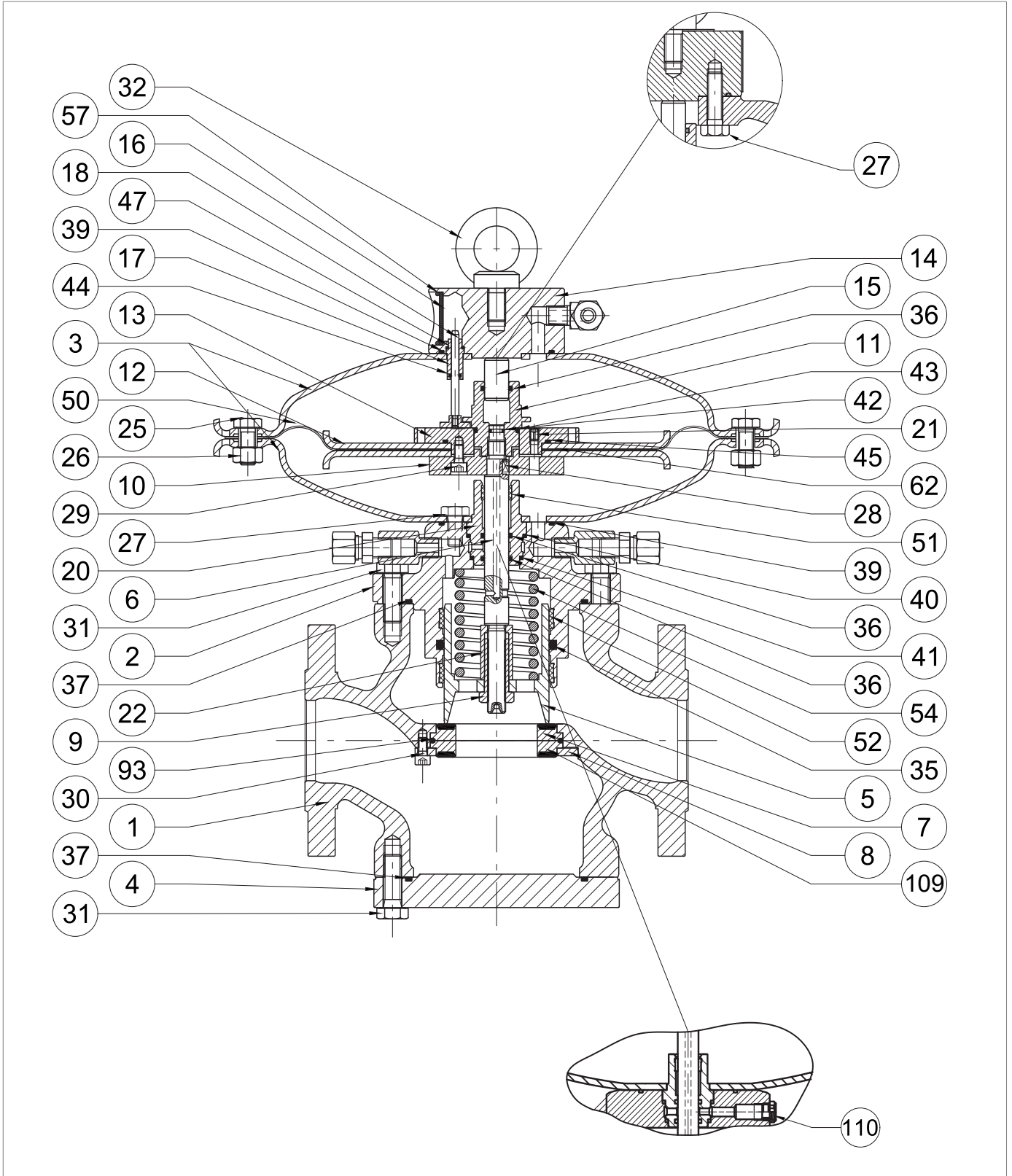

Regulator REVAL 182 1" ÷ 2"

Step	Action
58	<p>Remove the O-ring (37) from the blind flange (4) and replace it, lubricating it with synthetic grease.</p> <p>NOTICE! Before inserting the replacement O-ring, clean the retaining slots with a cleaning solution.</p>
59	<p>Unscrew and remove screws (30), shaft collar (8), reinforced gaskets (7, 109) and O-ring (93).</p> <p>NOTICE!</p> <ul style="list-style-type: none"> Take care that the upper seal does not fall off. If the SB/82 slam-shut valve is fitted, the conical seat replaces the reinforced gasket (109).
60	<p>Remove and replace the O-ring (93) from the reinforced gaskets (7, 109), lubricating it with synthetic grease.</p> <p>NOTICE! Before inserting the replacement O-ring, clean the retaining slots with a cleaning solution.</p>
61	<p>Position the reinforced gaskets (7, 109) and the shaft collar (8).</p> <p>NOTICE! If the SB/82 slam-shut valve is fitted, the conical seat replaces the reinforced gasket (109).</p>
62	<p>Insert and fix the screws (30) according to the following tightening torque:</p> <ul style="list-style-type: none"> 1": Tab. 9.90 2": Tab. 9.91 <p>NOTICE! Tighten the screws according to the cross diagram in paragraph 9.4.2.2.</p>
63	<p>Fit the blind flange (4).</p> <p>NOTICE! During this step, support the blind flange (4).</p>
64	<p>Insert and fix the screws of the lower section (31) according to the following tightening torque:</p> <ul style="list-style-type: none"> 1": Tab. 9.90 2": Tab. 9.91 <p>NOTICE! Tighten the screws according to the cross diagram in paragraph 9.4.2.2.</p>
65	<p>Position the control head inside the regulator body (1) with the indicator slide (16) visible and on axis with the gas flow direction.</p> <p>NOTICE! Take care not to damage the plug profile (5).</p>
66	<p>Insert and fix the screws of the upper section (31) according to the following tightening torque:</p> <ul style="list-style-type: none"> 1": Tab. 9.90 2": Tab. 9.91 <p>NOTICE! Tighten the screws according to the cross diagram in paragraph 9.4.2.2.</p>
67	<p>Connect the pneumatic connections between the regulator and the respective control unit, including downstream pressure ports.</p>

Tab. 9.144.

MAINTENANCE OF THE REGULATOR CAP

If there is no built-in SA slam shut valve, the cap (Fig. 9.68, ref. 140) closes the housing hole for the SA pressure switch (see 9.4.10).

The regulator cap is in a position perpendicular to the gas flow.

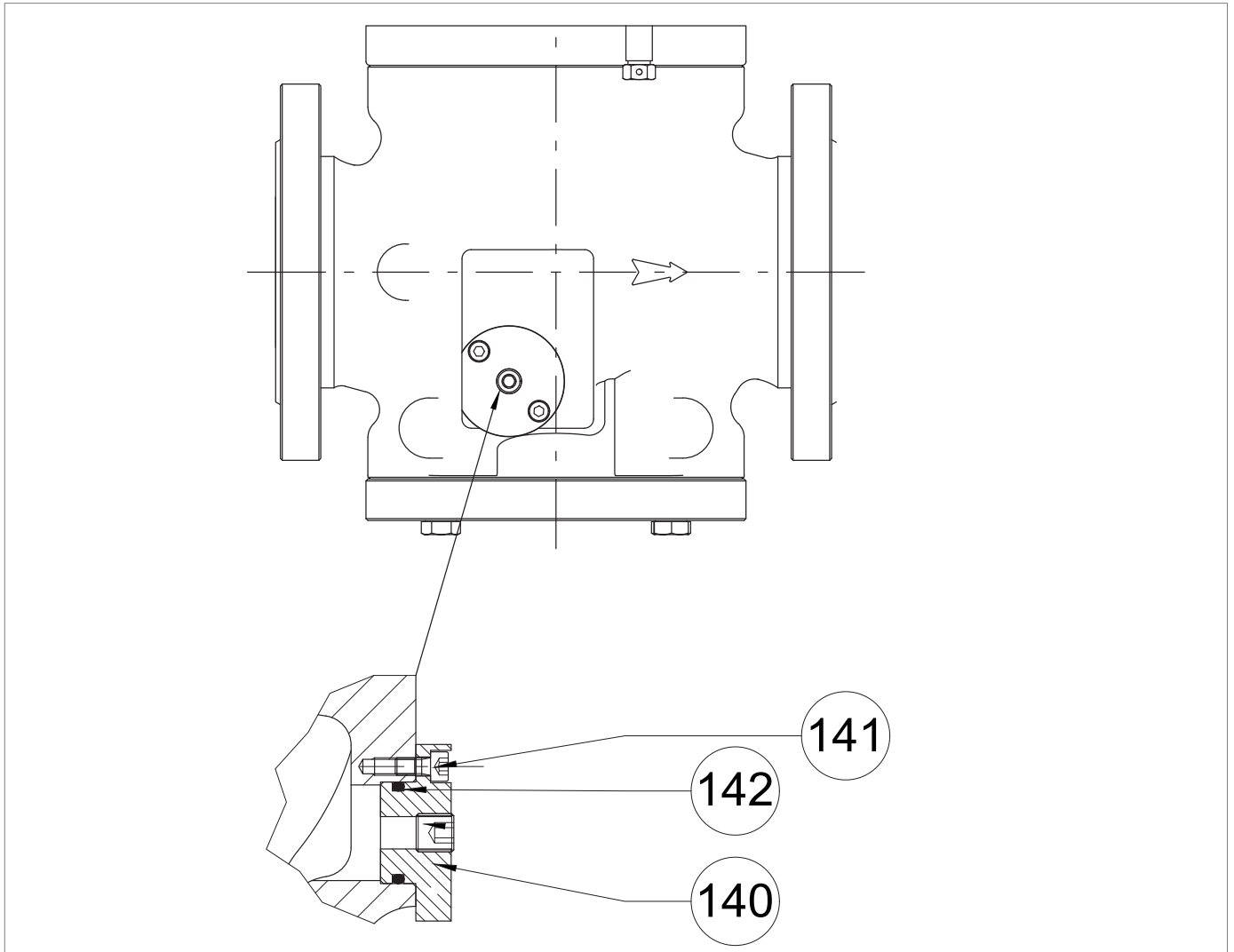



Fig. 9.68. Detail of the regulator cap

Step	Action
1	Unscrew and remove the screws (141).
2	Remove the cap (140).
3	Remove and replace O-ring (142), lubricating it with synthetic grease. <div style="border: 1px solid black; padding: 5px;">  NOTICE! Before inserting the replacement O-ring, clean the retaining slots with a cleaning solution. </div>
4	Insert cap (140).
5	Insert and fix the screws (141) according to the following tightening torque: <ul style="list-style-type: none"> • 1": Tab. 9.90 • 2": Tab. 9.91 <div style="border: 1px solid black; padding: 5px;">  NOTICE! Tighten the screws according to the cross diagram in paragraph 9.4.2.2. </div>

Tab. 9.145.

 **WARNING!**

Ensure that all parts have been fitted correctly.

9.4.3.2 - REGULATOR REVAL 182 2" ½ ÷ 4"

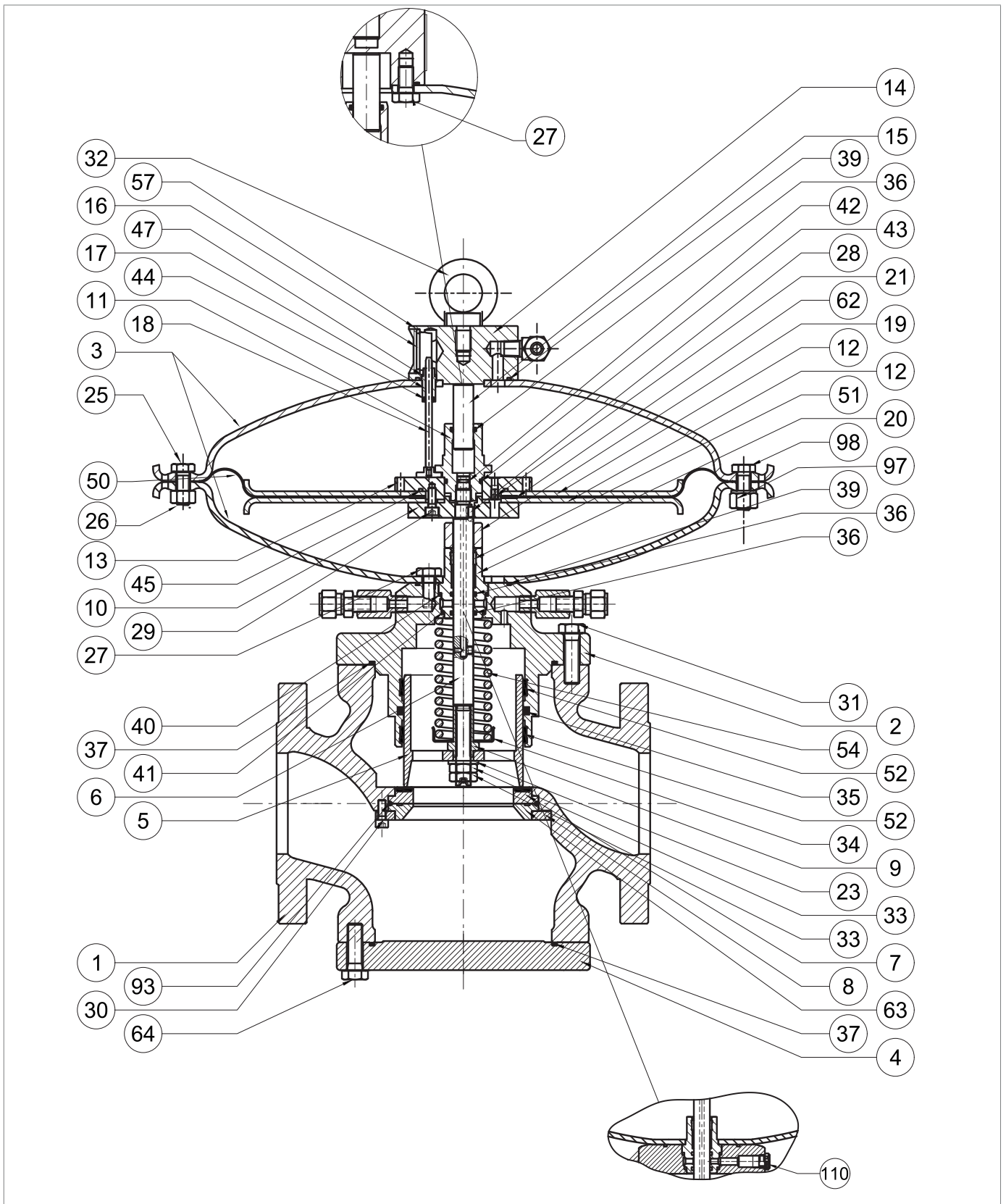
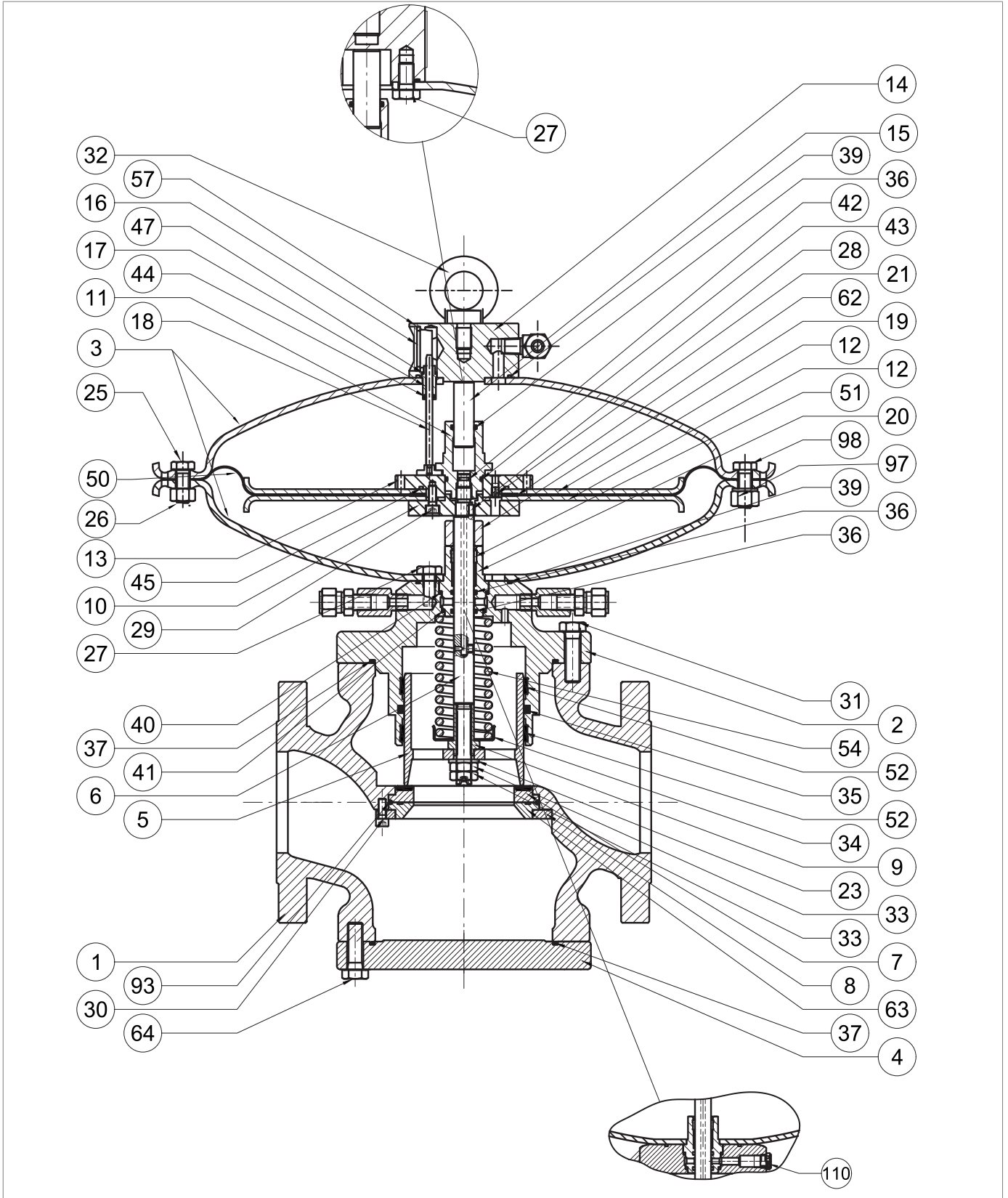

Fig. 9.69. Regulator REVAL 182 2" ½ ÷ 4"

Step	Action
1	<p>Unscrew and remove the screws on the upper part (31) which secure the control head to the regulator body (1).</p> <p>! NOTICE!</p> <p>Support the head assembly during this step to avoid falls.</p>
2	<p>Remove the control head and place it on its side in a plane with an impact-resistant surface.</p> <p>! NOTICE!</p> <p>Take care not to damage the plug profile (5).</p>
3	<p>Remove the O-ring (37) from the plug guide (2) and replace it, lubricating it with synthetic grease.</p> <p>! NOTICE!</p> <p>Before inserting the replacement O-ring, clean the retaining slots with a cleaning solution.</p>
4	<p>Unscrew and remove the nuts (33) together with the washer (23).</p> <p>! NOTICE!</p> <p>During this phase, the spring (54) decompresses and pushes the plug (5) outwards.</p>
5	<p>Remove the plug (5) and place it on an anti-shock surface.</p> <p>! NOTICE!</p> <p>Take care not to damage the plug profile (5).</p>
6	Unscrew the lock nut (9).
7	Remove the spring support (34) and the spring (54).
8	<p>Remove and replace the I/DWR rings (52) from the plug guide (2).</p> <p>! NOTICE!</p> <p>Before inserting the replacement I/DWR rings, clean the retaining slots with a cleaning solution.</p>
9	<p>Remove the O-ring (35) from the plug guide (2) and replace it, lubricating it with synthetic grease.</p> <p>! NOTICE!</p> <p>Before inserting the replacement O-ring, clean the retaining slots with a cleaning solution.</p>
10	Unscrew and remove the nuts (26) together with the screws (25).
11	Unscrew and remove the pilot screw (98) together with the nut (97).
12	Remove the upper lid (3).
13	Remove the indicator rod (18) from the rod guide (17).
14	Unscrew and remove the top screws (27) from the top cover (3).
15	Separate the upper cover (3) from the eyebolt flange (14).
16	Take out the rod guide (17).
17	<p>Remove the O-rings (39, 47) from the eyebolt flange (14) and replace them, lubricating them with synthetic grease.</p> <p>! NOTICE!</p> <p>Before inserting the replacement O-ring, clean the retaining slots with a cleaning solution.</p>



Regulator REVAL 182 2" 1/2 - 4"

Step	Action
18	<p>Remove the O-ring (44) from the rod guide (17) and replace it, lubricating it with synthetic grease.</p> <div style="border: 1px solid black; padding: 5px;"> <p>! NOTICE!</p> <p>Before inserting the replacement O-ring, clean the retaining slots with a cleaning solution.</p> </div>
19	Place the rod guide (17) in the eyebolt flange (14).
20	Assemble the eyebolt flange (14) with the upper lid (3).
21	<p>Insert and fasten the screws of the upper part (27) in the upper cover according to the tightening torque:</p> <ul style="list-style-type: none"> • 2" ½: Tab. 9.92 • 3": Tab. 9.93 • 4": Tab. 9.94 <div style="border: 1px solid black; padding: 5px;"> <p>! NOTICE!</p> <p>Tighten the screws according to the cross diagram in paragraph 9.4.2.2.</p> </div>
22	Insert the indicator rod (18) into the rod guide (17).
23	<p>Unscrew and remove the balancing stem guide (11).</p> <div style="border: 1px solid black; padding: 5px;"> <p>! NOTICE!</p> <p>Hold the diaphragm assembly in place by positioning the spanner in the holes in the upper diaphragm support (13).</p> </div>
24	Remove the balancing piston (15) from the balancing stem guide (11).
25	<p>Remove and replace the O-rings (36, 43) from the balancing stem guide (11), lubricating them with synthetic grease.</p> <div style="border: 1px solid black; padding: 5px;"> <p>! NOTICE!</p> <p>Before inserting the replacement O-rings, clean the retaining slots with a cleaning solution.</p> </div>
26	Position the balancing piston (15) in the balancing stem guide (11).
27	Take out the diaphragm unit (10, 12, 13, 21, 29, 45, 50, 62)
28	Unscrew and remove the screws (29) from the lower diaphragm support (10).
29	Remove the lower diaphragm support (10) and the lower diaphragm protection disc (12).
30	Remove and replace the diaphragm (50) together with the oil seal (62).
31	Remove the lower diaphragm protection disc (12) from the upper diaphragm holder (13).
32	<p>Remove and replace the O-ring (45) from the upper diaphragm support (13), lubricating it with synthetic grease.</p> <div style="border: 1px solid black; padding: 5px;"> <p>! WARNING!</p> <p>Before inserting the replacement O-ring, clean the retaining slots with a cleaning solution.</p> </div>
33	<p>Place the upper diaphragm protection disc (12) in the upper diaphragm holder (13).</p> <div style="border: 1px solid black; padding: 5px;"> <p>! NOTICE!</p> <p>Check that the hole on the nozzle (21) is free from dirt or foreign bodies.</p> </div>
34	<p>Position the diaphragm (50).</p> <div style="border: 1px solid black; padding: 5px;"> <p>! NOTICE!</p> <p>The concave part of the diaphragm must face the drive chamber (pos. B, fig. 4.2).</p> </div>

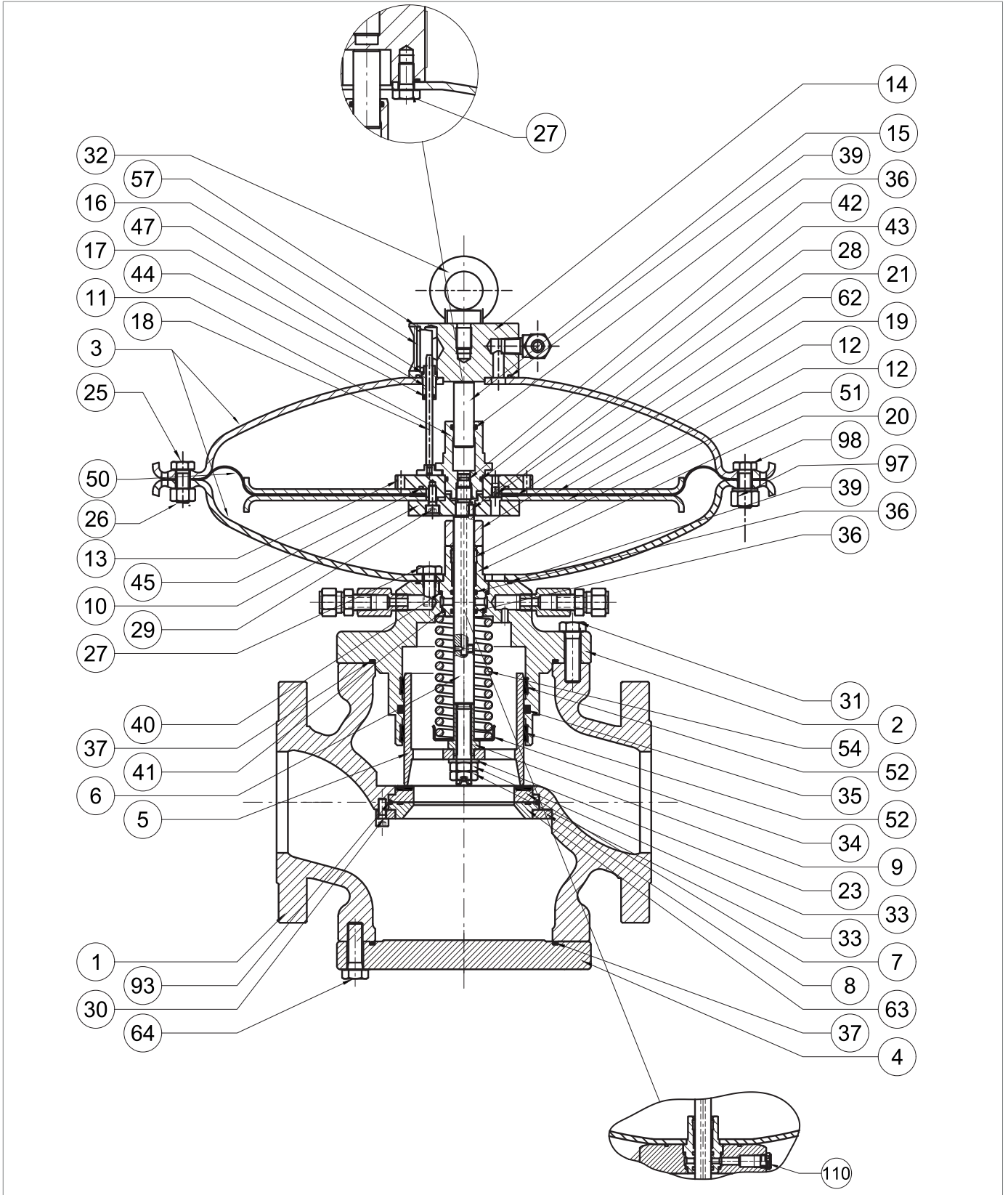

Regulator REVAL 182 2" 1/2 - 4"

Step	Action
35	Position the oil seal (62).
36	Put the lower diaphragm protection disc (12) and the lower diaphragm support (10) in place. NOTICE! Check that the nozzle hole on the upper diaphragm support (13) is aligned with the hole on the lower diaphragm support (10).
37	Apply thread locking glue to insert and fix the screws (29) according to the following tightening torque: <ul style="list-style-type: none"> • 2" ½: Tab. 9.92 • 3": Tab. 9.93 • 4": Tab. 9.94 NOTICE! Tighten the screws according to the cross diagram in paragraph 9.4.2.2.
38	Unscrew and remove the lower part screws (27) from the lower cover (3).
39	Remove the lower cover (3).
40	Remove the O-ring (39) from the plug guide (2) and replace it, lubricating it with synthetic grease. NOTICE! Before inserting the replacement O-ring, clean the retaining slots with a cleaning solution.
41	Remove the spacer (19).
42	Remove the stem guide (20), the stem (6) and the key (28).
43	Remove and replace the I/DWR rings (51) from the stem guide (20). NOTICE! Before inserting the replacement O-ring, clean the retaining slots with a cleaning solution.
44	Remove the O-rings (36) from the stem guide (20) and replace them, lubricating them with synthetic grease. NOTICE! Before inserting the replacement O-rings, clean the retaining slots with a cleaning solution.
45	Remove the O-rings (40, 41) from the stem guide (20) and replace them, lubricating them with synthetic grease. NOTICE! Before inserting the replacement O-rings, clean the retaining slots with a cleaning solution.
46	Remove the O-ring (42) from the stem (6) and replace it, lubricating it with synthetic grease. NOTICE! Before inserting the replacement O-ring, clean the retaining slots with a cleaning solution.
47	Remove the stem guide (20), the stem (6) and the key (28). NOTICE! <ul style="list-style-type: none"> • Lubricate the stem surface with silicone grease • The key (28) must be in the correct position in the stem (6)

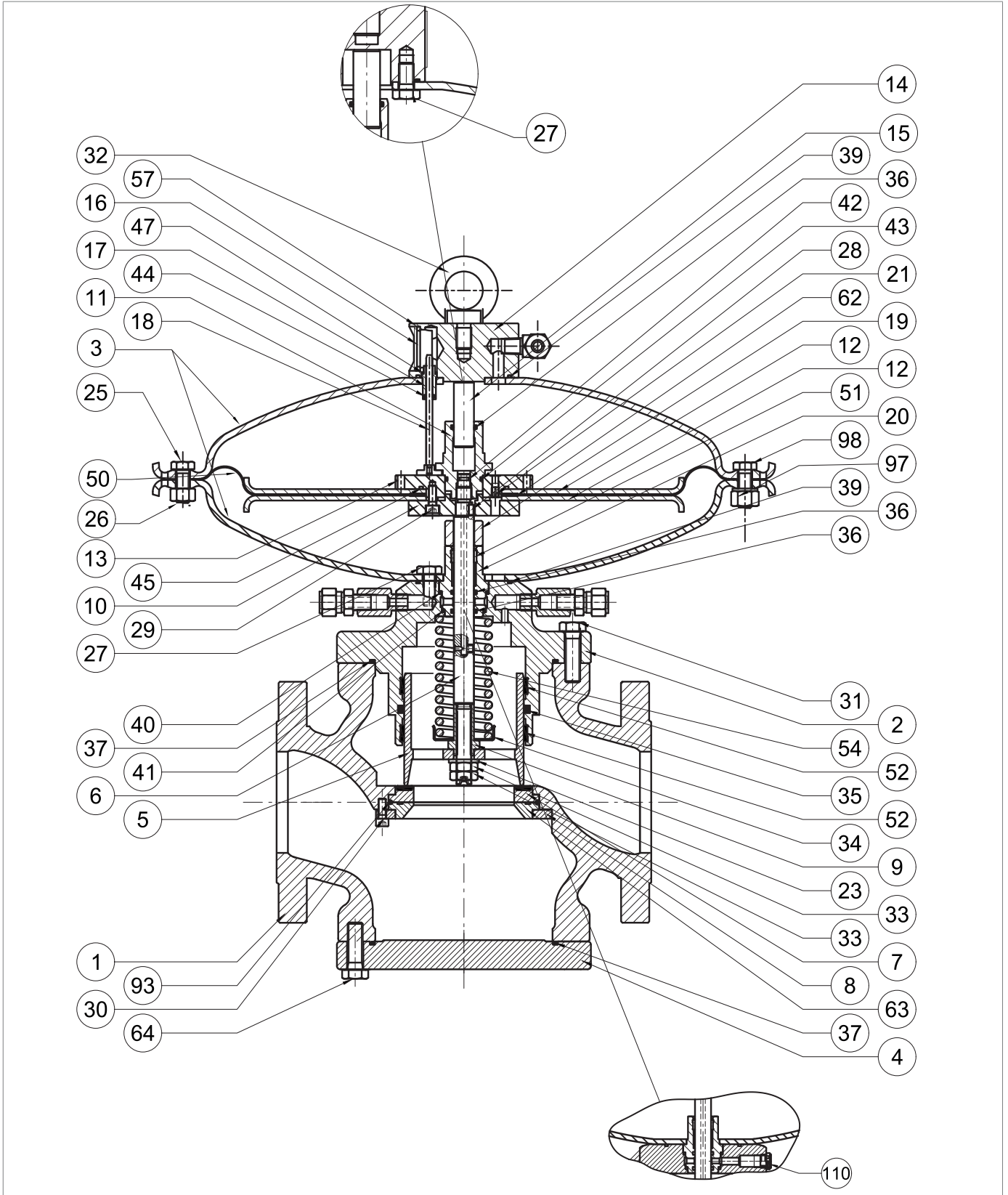

Regulator REVAL 182 2" 1/2 - 4"

Step	Action
48	Position the spacer (19).
49	Place the lower cover (3) on the plug guide (2). NOTICE! Match the hole for the passage of the loading pressure to the similar one on the plug guide.
50	Insert and fasten the screws of the lower part (27) in the lower cover (3) according to the tightening torque: <ul style="list-style-type: none"> • 2" ½: Tab. 9.92 • 3": Tab. 9.93 • 4": Tab. 9.94 NOTICE! Tighten the screws according to the cross diagram in paragraph 9.4.2.2.
51	Put the diaphragm unit in place (10, 12, 13, 21, 29, 45, 50, 62).
52	Insert and secure the balancing stem guide (11) according to the tightening torque: <ul style="list-style-type: none"> • 2" ½: Tab. 9.92 • 3": Tab. 9.93 • 4": Tab. 9.94 NOTICE! Hold the diaphragm assembly in place by positioning the spanner in the holes in the upper diaphragm support (13).
53	Position the upper cover (3), taking care to position the indicator stem (18) in the space between the upper diaphragm support (13) and the balance stem guide (11). NOTICE! <ul style="list-style-type: none"> • The indicator rod (18) must not obstruct the pouring hole (21) on the upper diaphragm support (13) • The flange travel indicator must be visible and perpendicular to the gas flow
54	Insert and fasten the screws (25) with the nuts (26) according to the tightening torque: <ul style="list-style-type: none"> • 2" ½: Tab. 9.92 • 3": Tab. 9.93 • 4": Tab. 9.94 NOTICE! Tighten the screws according to the cross diagram in paragraph 9.4.2.2.
55	Position the spring holder (34) and spring (54). NOTICE! Check that the spring (54) is properly seated in the centring stop on the plug guide (2).
56	Insert locking nut (9)
57	Insert the plug (5).
58	Insert the washer (23).

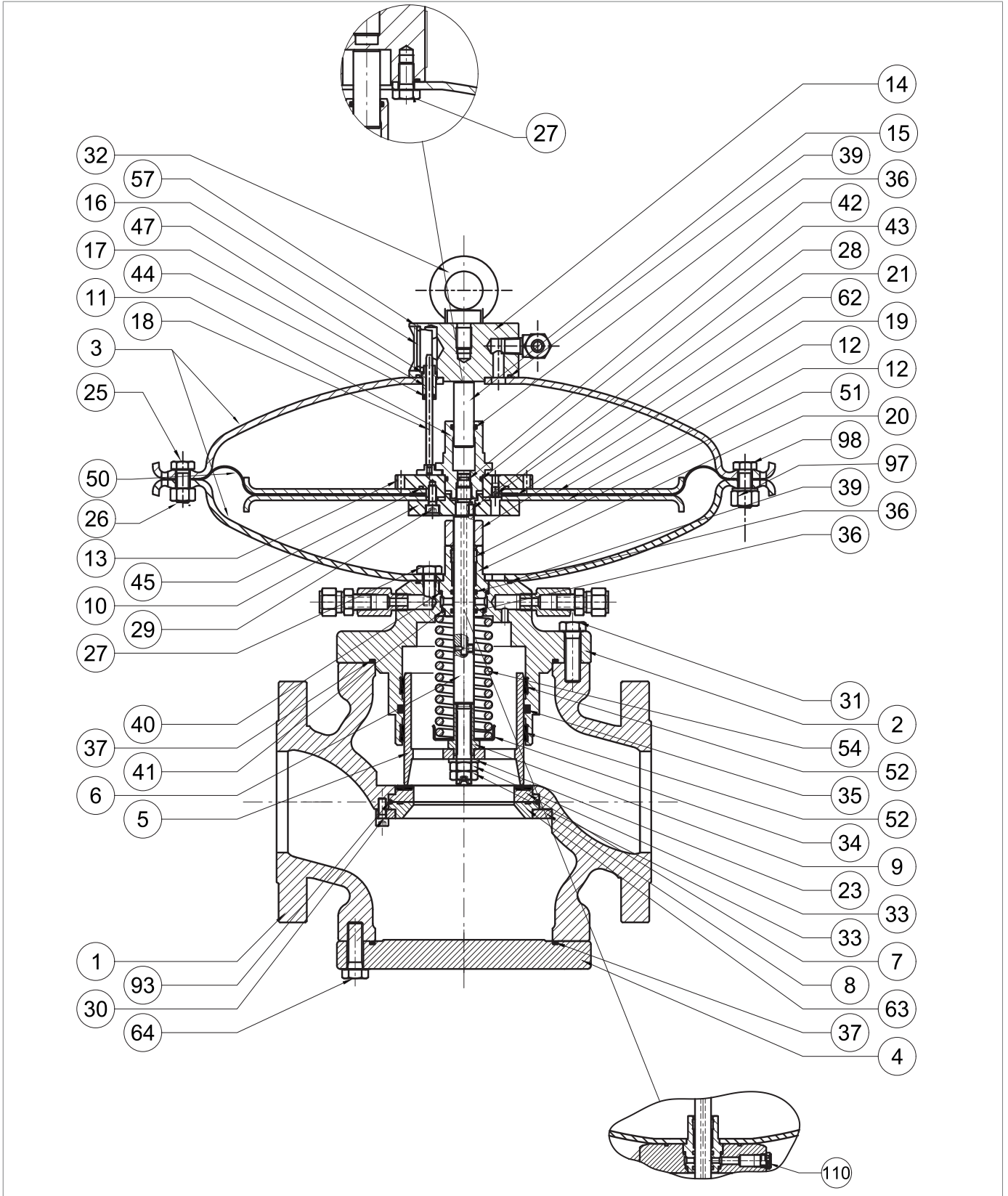

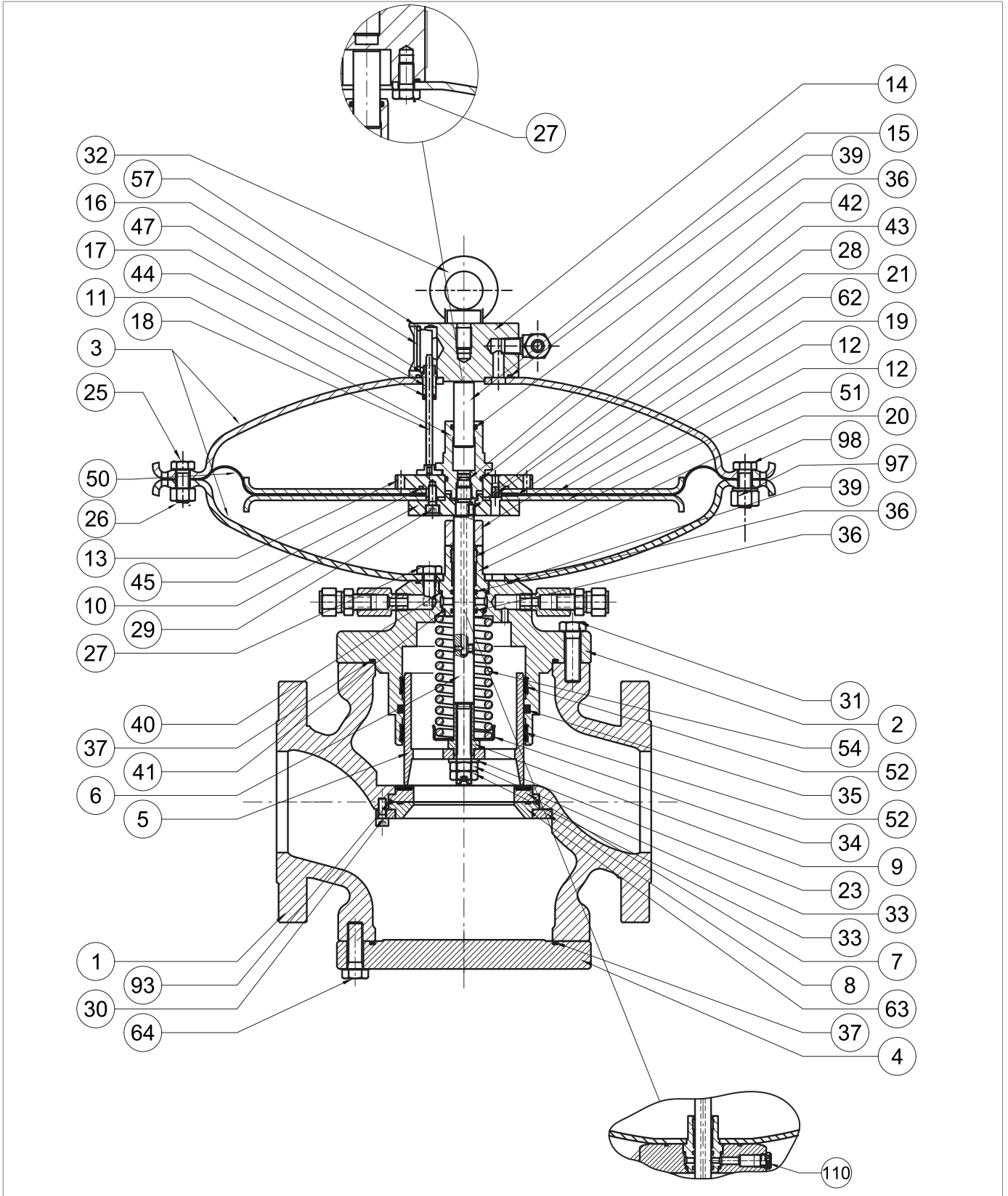

Regulator REVAL 182 2" 1/2 - 4"

Step	Action
59	<p>Insert and secure the locking nuts (33), applying threadlocking glue, according to the tightening torque:</p> <ul style="list-style-type: none"> • 2" ½: Tab. 9.92 • 3": Tab. 9.93 • 4": Tab. 9.94 <p>NOTICE!</p> <p>During this phase, manually compress the spring (54).</p>
60	Undo and remove the screws (64).
61	<p>Remove the blind flange (4).</p> <p>NOTICE!</p> <p>During this step, take care to support the blind flange (4).</p>
62	<p>Remove the O-ring (37) and replace it, lubricating it with synthetic grease.</p> <p>NOTICE!</p> <p>Before inserting the replacement O-ring, clean the retaining slots with a cleaning solution.</p>
63	<p>Unscrew and remove screws (30), shaft collar (8), reinforced gaskets (7, 63) and O-ring (93).</p> <p>NOTICE!</p> <ul style="list-style-type: none"> • Take care that the upper seal does not fall off. • If the SB/82 slam-shut valve is fitted, the conical seat replaces the reinforced gasket (63).
64	<p>Remove the O-ring (93) from the reinforced gasket (7) and replace it, lubricating it with synthetic grease.</p> <p>NOTICE!</p> <p>Before inserting the replacement O-ring, clean the retaining slots with a cleaning solution.</p>
65	Clean the upper and lower supporting surfaces of the body, the flanges, the contact surfaces between the reinforced gasket (7) and the regulator body (1), and between the reinforced gasket (63) and the regulator body (1).
66	<p>Position the reinforced gaskets (7, 63) and the shaft collar (8).</p> <p>NOTICE!</p> <p>If the SB/82 slam-shut valve is fitted, the conical seat replaces the reinforced gasket (63).</p>
67	<p>Insert and fix the screws (30) according to the following tightening torque:</p> <ul style="list-style-type: none"> • 2" ½: Tab. 9.92 • 3": Tab. 9.93 • 4": Tab. 9.94 <p>NOTICE!</p> <p>Tighten the screws according to the cross diagram in paragraph 9.4.2.2.</p>
68	Position the blind flange (4), taking care to support it.
69	<p>Insert and fix the screws (64) according to the following tightening torque:</p> <ul style="list-style-type: none"> • 2" ½: Tab. 9.92 • 3": Tab. 9.93 • 4": Tab. 9.94 <p>NOTICE!</p> <p>Tighten the screws according to the cross diagram in paragraph 9.4.2.2.</p>



Regulator REVAL 182 2" ½ - 4"

Step	Action
70	Position the control head inside the regulator body (1) with the indicator slide (16) visible and on axis with the gas flow direction. <div style="border: 1px solid black; padding: 5px;">  NOTICE! Take care not to damage the plug profile (5). </div>
71	Insert and fix the screws of the upper section (31) according to the following tightening torque: <ul style="list-style-type: none"> • 2 ½": tab. 9.93 • 3": tab. 9.94 • 4": tab. 9.95 <div style="border: 1px solid black; padding: 5px;">  NOTICE! Tighten the screws according to the cross diagram in paragraph 9.4.2.2. </div>

Tab. 9.146.

 **WARNING!**

Ensure that all parts have been fitted correctly.

MAINTENANCE OF THE REGULATOR CAP

If there is no built-in SA slam shut valve, the cap (Fig. 9.70, ref. 140) closes the housing hole for the SA pressure switch (see par. 9.4.10).

The regulator cap is in a position perpendicular to the gas flow.

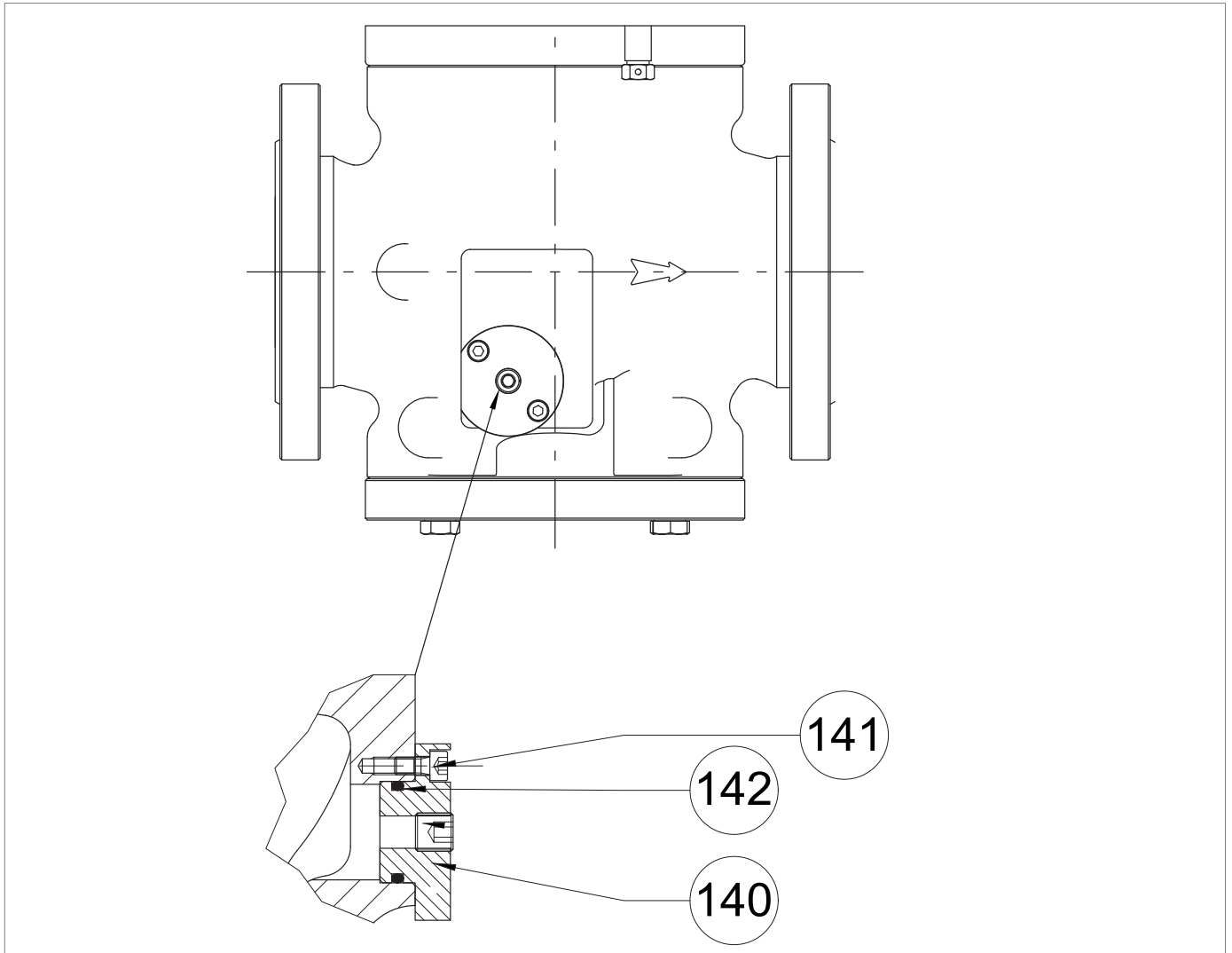



Fig. 9.70. Detail of the regulator cap

Step	Action
1	Unscrew and remove the screws (141).
2	Remove the cap (140).
3	Remove and replace O-ring (142), lubricating it with synthetic grease. <div style="border: 1px solid black; padding: 5px;">  NOTICE! Before inserting the replacement O-ring, clean the retaining slots with a cleaning solution. </div>
4	Insert cap (140).
5	Insert and fix the screws (141) according to the following tightening torque: <ul style="list-style-type: none"> • 2" ½: Tab. 9.92 • 3": Tab. 9.93 • 4": Tab. 9.94 <div style="border: 1px solid black; padding: 5px;">  NOTICE! Tighten the screws according to the cross diagram in paragraph 9.4.2.2. </div>

Tab. 9.147.

 **WARNING!**

Ensure that all parts have been fitted correctly.

9.4.3.3 - REGULATOR REVAL 182 6" - 8"

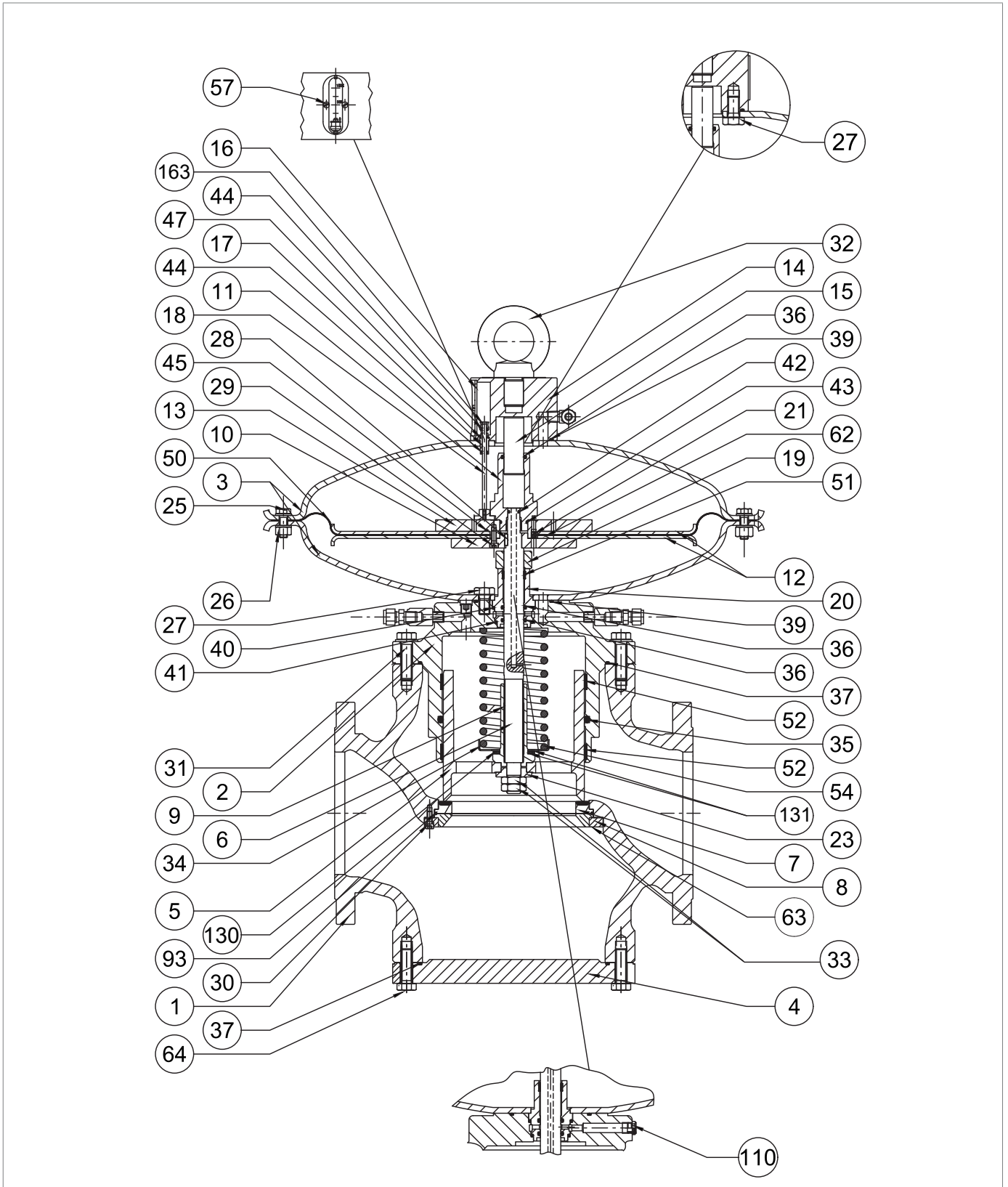
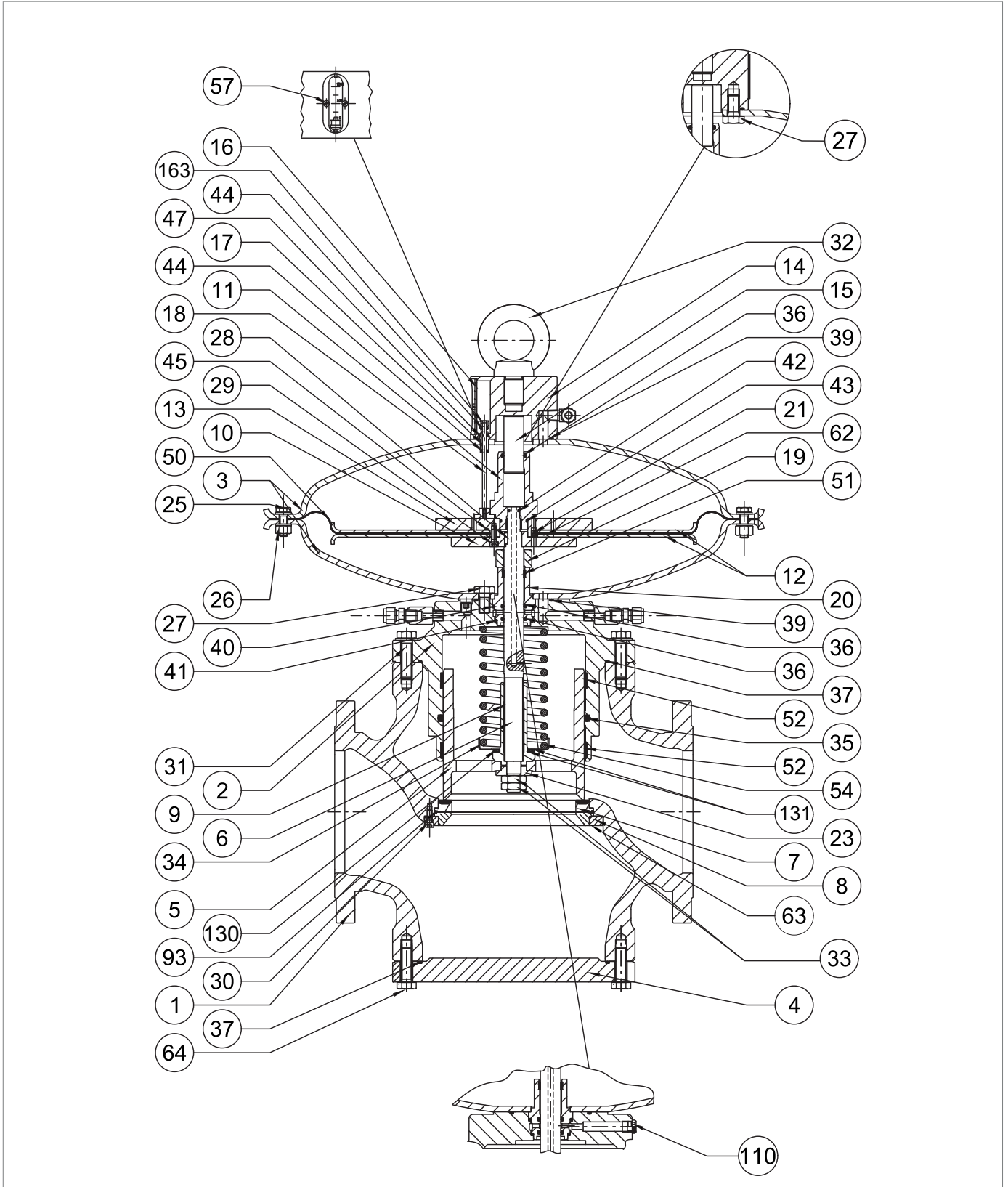

Fig. 9.71. Regulator REVAL 182 6" - 8"

Step	Action
1	<p>Unscrew and remove the screws on the upper part (31) which secure the control head to the regulator body (1).</p> <div style="border: 1px solid black; padding: 5px;"> <p>! NOTICE!</p> <p>Support the head assembly during this step to avoid falls.</p> </div>
2	<p>Remove the control head and place it on its side on a plane with an impact-resistant surface.</p> <div style="border: 1px solid black; padding: 5px;"> <p>! NOTICE!</p> <p>Take care not to damage the plug profile (5).</p> </div>
3	<p>Remove the O-ring (37) from the plug guide (2) and replace it, lubricating it with synthetic grease.</p> <div style="border: 1px solid black; padding: 5px;"> <p>! NOTICE!</p> <p>Before inserting the replacement O-ring, clean the retaining slots with a cleaning solution.</p> </div>
4	Unscrew and remove the nuts (33) together with the washer (23).
5	Remove the plug (5) and place it on a table with an impact-resistant surface.
6	<p>Unscrew the locking nut (9) to release the spring.</p> <div style="border: 1px solid black; padding: 5px;"> <p>! NOTICE!</p> <p>Take care not to damage the plug profile (5).</p> </div>
7	Remove the washers (131) and radial bearings (130).
8	Remove the spring support (34) and the spring (54).
9	<p>Remove and replace the I/DWR rings (52) from the plug guide (2).</p> <div style="border: 1px solid black; padding: 5px;"> <p>! NOTICE!</p> <p>Before inserting the replacement I/DWR rings, clean the retaining slots with a cleaning solution.</p> </div>
10	<p>Remove the O-ring (35) from the plug guide (2) and replace it, lubricating it with synthetic grease.</p> <div style="border: 1px solid black; padding: 5px;"> <p>! NOTICE!</p> <p>Before inserting the replacement O-ring, clean the retaining slots with a cleaning solution.</p> </div>
11	Unscrew and remove the nuts (26) together with the screws (25).
12	Remove the upper lid (3).
13	Remove the indicator rod (18) from the rod guide (17).
14	Unscrew and remove the top screws (27) from the top cover (3).
15	Separate the upper cover (3) from the eyebolt flange (14).
16	Take out the rod guide (17).
17	<p>Remove the O-rings (39, 47) from the eyebolt flange (14) and replace them, lubricating them with synthetic grease.</p> <div style="border: 1px solid black; padding: 5px;"> <p>! NOTICE!</p> <p>Before inserting the replacement O-ring, clean the retaining slots with a cleaning solution.</p> </div>
18	<p>Remove the O-ring (44) from the rod guide (17) and replace it, lubricating it with synthetic grease.</p> <div style="border: 1px solid black; padding: 5px;"> <p>! NOTICE!</p> <p>Before inserting the replacement O-ring, clean the retaining slots with a cleaning solution.</p> </div>



Regulator REVAL 182 6" - 8"

Step	Action
19	Unscrew and remove the position screws (57) together with the indicator slide (16) and pawl (163).
20	Remove and replace the O-ring (44) from the pawl (163), lubricating it with synthetic grease. NOTICE! Before inserting the replacement O-ring, clean the retaining slots with a cleaning solution.
21	Place the rod guide (17) in the eyebolt flange (14).
22	Assemble the eyebolt flange (14) with the upper lid (3).
23	Insert and fasten the screws of the upper part (27) in the upper cover (3) according to the tightening torque: <ul style="list-style-type: none"> • 6": Tab. 9.95 • 8": Tab. 9.96 NOTICE! Tighten the screws according to the cross diagram in paragraph 9.4.2.2.
24	Insert the indicator rod (18) into the rod guide (17).
25	Unscrew and remove the balancing stem guide (11). NOTICE! Hold the diaphragm assembly in place by positioning the spanner in the holes in the upper diaphragm support (13).
26	Remove the balancing piston (15) from the balancing stem guide (11).
27	Remove and replace the O-rings (36, 43) from the balancing stem guide (11), lubricating them with synthetic grease. NOTICE! Before inserting the replacement O-rings, clean the retaining slots with a cleaning solution.
28	Position the balancing piston (15) in the balancing stem guide (11).
29	Take out the diaphragm unit (10, 12, 13, 21, 29, 45, 50, 62)
30	Unscrew and remove the screws (29) from the lower diaphragm support (10).
31	Remove the diaphragm support (10) and the lower diaphragm protection disc (12).
32	Remove the diaphragm (50) together with the oil seal (62).
33	Remove the upper diaphragm support (13) from the lower diaphragm protection disc (12).
34	Remove and replace the O-ring (45) from the upper diaphragm support (13), lubricating it with synthetic grease. NOTICE! Before inserting the replacement O-ring, clean the retaining slots with a cleaning solution.
35	Place the upper diaphragm protection disc (12) in the upper diaphragm holder (13). NOTICE! Check that the hole on the nozzle (21) is free from dirt or foreign bodies.

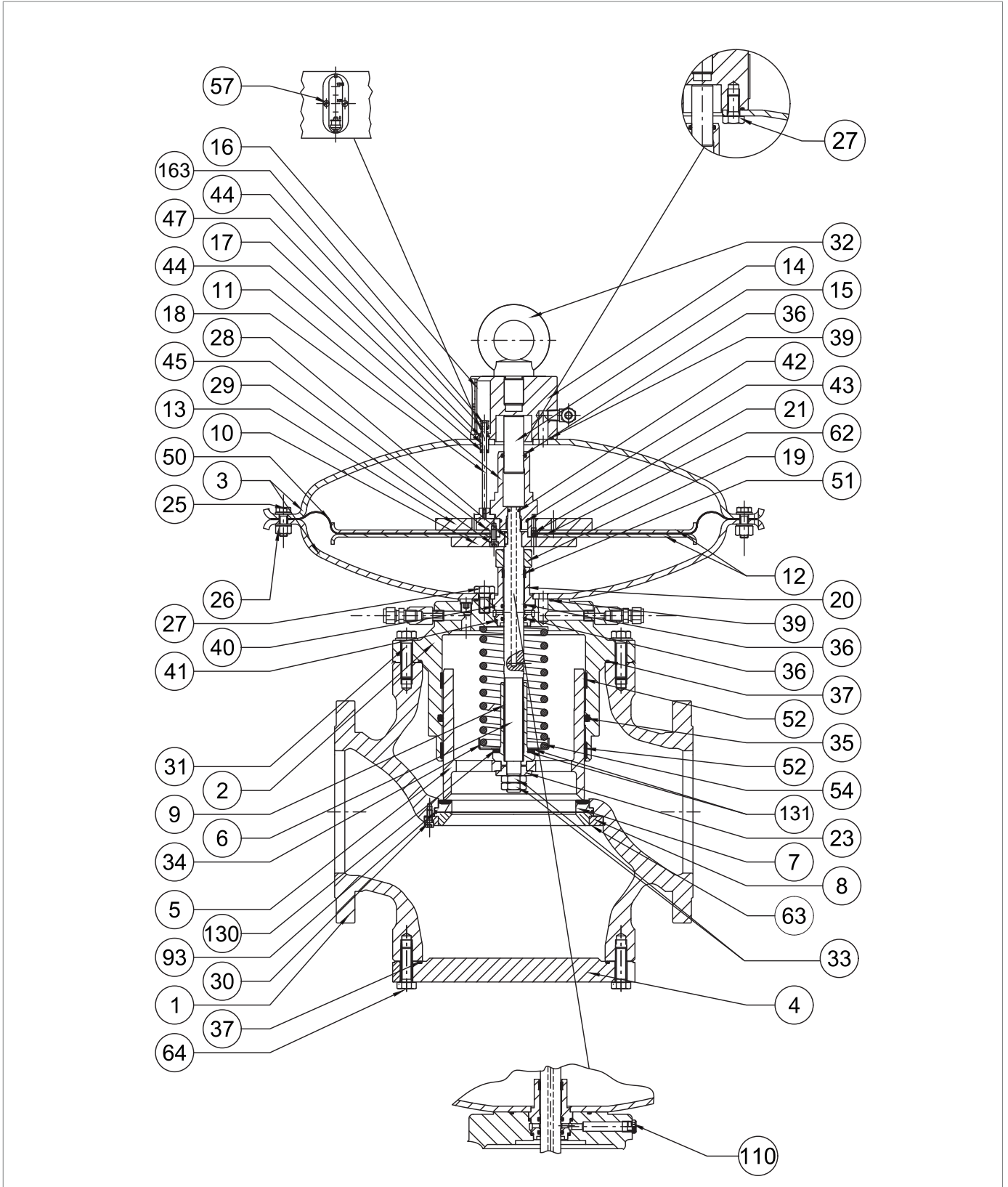

Regulator REVAL 182 6" - 8"

Step	Action
36	Position the oil seal (62).
37	Position the diaphragm (50). ! NOTICE! The concave part of the diaphragm must face the drive chamber (pos. B, fig. 4.2).
38	Put the diaphragm protection disc (12) and the lower diaphragm support (10) in place. ! NOTICE! Check that the nozzle hole on the upper diaphragm support (13) is aligned with the hole on the lower diaphragm support (10).
39	Apply thread locking glue to insert and fix the screws (29) according to the following tightening torque: <ul style="list-style-type: none"> • 6": Tab. 9.95 • 8": Tab. 9.96 ! NOTICE! Tighten the screws according to the cross diagram in paragraph 9.4.2.2.
40	Unscrew and remove the lower part screws (27) from the lower cover (3).
41	Remove the lower cover (3).
42	Remove the O-ring (39) from the plug guide (2) and replace it, lubricating it with synthetic grease. ! NOTICE! Before inserting the replacement O-ring, clean the retaining slots with a cleaning solution.
43	Remove the stem guide (20), the stem (6) and the key (28).
44	Remove and replace the I/DWR rings (51) from the stem guide (20). ! NOTICE! Before inserting the replacement O-ring, clean the retaining slots with a cleaning solution.
45	Remove the O-rings (36) from the stem guide (20) and replace them, lubricating them with synthetic grease. ! NOTICE! Before inserting the replacement O-rings, clean the retaining slots with a cleaning solution.
46	Remove the O-rings (40, 41) from the stem guide (20) and replace them, lubricating them with synthetic grease. ! NOTICE! Before inserting the replacement O-rings, clean the retaining slots with a cleaning solution.
47	Remove the O-ring (42) from the stem (6) and replace it, lubricating it with synthetic grease. ! NOTICE! Before inserting the replacement O-ring, clean the retaining slots with a cleaning solution.

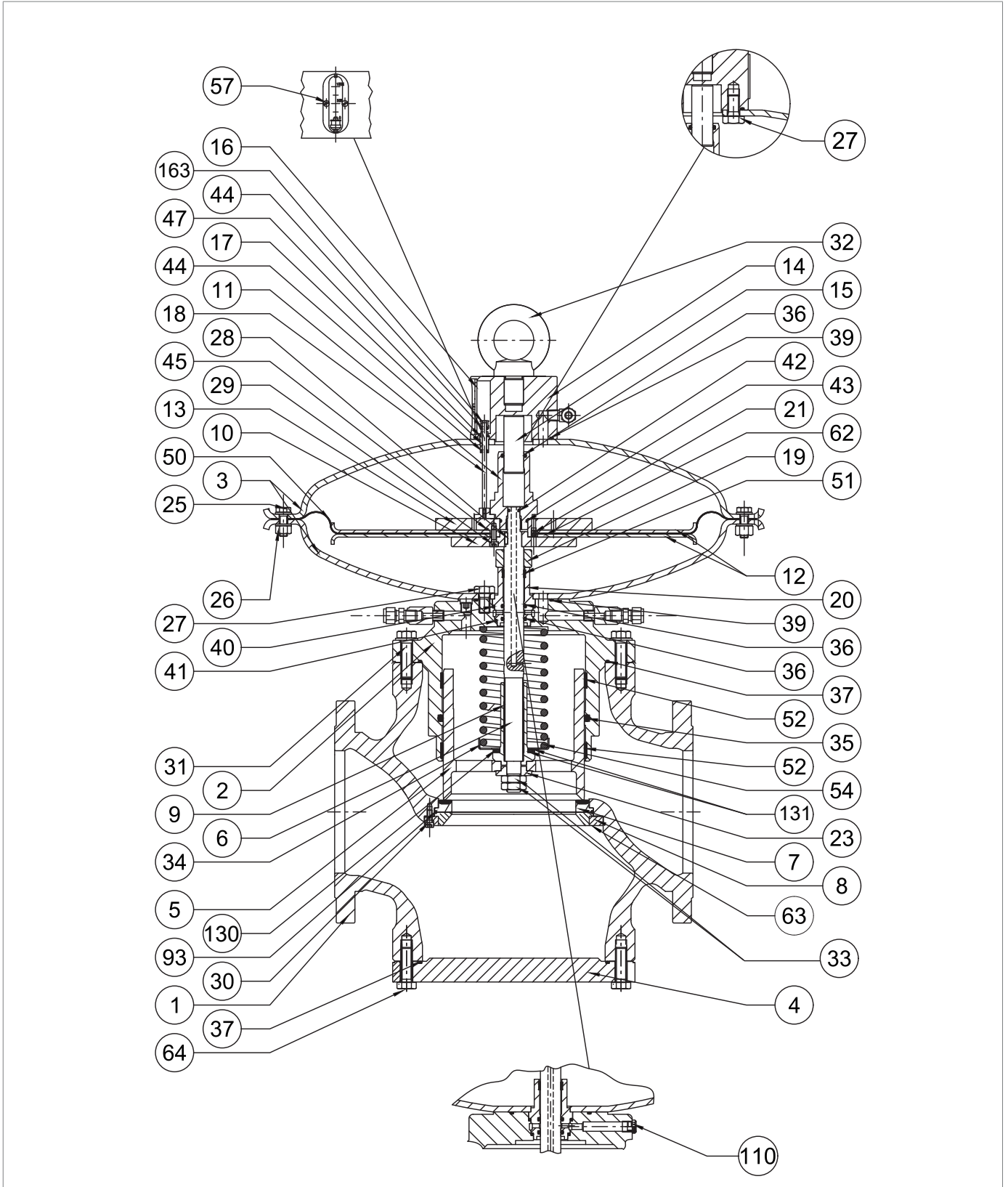

Regulator REVAL 182 6" - 8"

Step	Action
48	<p>Remove the stem guide (20), the stem (6) and the key (28).</p> <div style="border: 1px solid black; padding: 5px;"> <p>! NOTICE!</p> <ul style="list-style-type: none"> • Lubricate the stem surface with silicone grease • Make sure that the key (28) is in the correct position in the stem (6). </div>
49	<p>Put the lower cover (3) in place and fix it on the plug guide (2).</p> <div style="border: 1px solid black; padding: 5px;"> <p>! NOTICE!</p> <p>Match the hole for the passage of the loading pressure to the similar one on the plug guide.</p> </div>
50	<p>Insert and fasten the screws of the lower part (27) in the lower cover (3) according to the tightening torque:</p> <ul style="list-style-type: none"> • 6": Tab. 9.95 • 8": Tab. 9.96 <div style="border: 1px solid black; padding: 5px;"> <p>! NOTICE!</p> <p>Tighten the screws according to the cross diagram in paragraph 9.4.2.2.</p> </div>
51	Put the diaphragm unit in place (10, 12, 13, 21, 29, 45, 50, 62).
52	<p>Insert and secure the balancing stem guide (11) according to the tightening torque:</p> <ul style="list-style-type: none"> • 6": Tab. 9.95 • 8": Tab. 9.96 <div style="border: 1px solid black; padding: 5px;"> <p>! NOTICE!</p> <p>During this step, hold the diaphragm assembly in place by positioning the spanner in the holes in the upper diaphragm support (13).</p> </div>
53	<p>Position the upper cover (3), taking care to position the indicator stem (18) in the space between the upper diaphragm support (13) and the balance stem guide (11).</p> <div style="border: 1px solid black; padding: 5px;"> <p>! NOTICE!</p> <ul style="list-style-type: none"> • The indicator rod (18) must not obstruct the hole on the upper diaphragm support (13); • The flange travel indicator must be visible and perpendicular to the gas flow </div>
54	<p>Insert and fasten the screws (25) with the nuts (26) according to the tightening torque:</p> <ul style="list-style-type: none"> • 6": Tab. 9.95 • 8": Tab. 9.96 <div style="border: 1px solid black; padding: 5px;"> <p>! NOTICE!</p> <p>Tighten the screws according to the cross diagram in paragraph 9.4.2.2.</p> </div>
55	<p>Put the spring (54) and spring support (34) in place.</p> <div style="border: 1px solid black; padding: 5px;"> <p>! NOTICE!</p> <p>Check that the spring (54) is properly seated in the centring stop on the plug guide (2).</p> </div>
57	Insert slewing ring (131) and radial bearing (130).
58	<p>Insert the locking nut (9) according to the tightening torque:</p> <ul style="list-style-type: none"> • 6": Tab. 9.95 • 8": Tab. 9.96

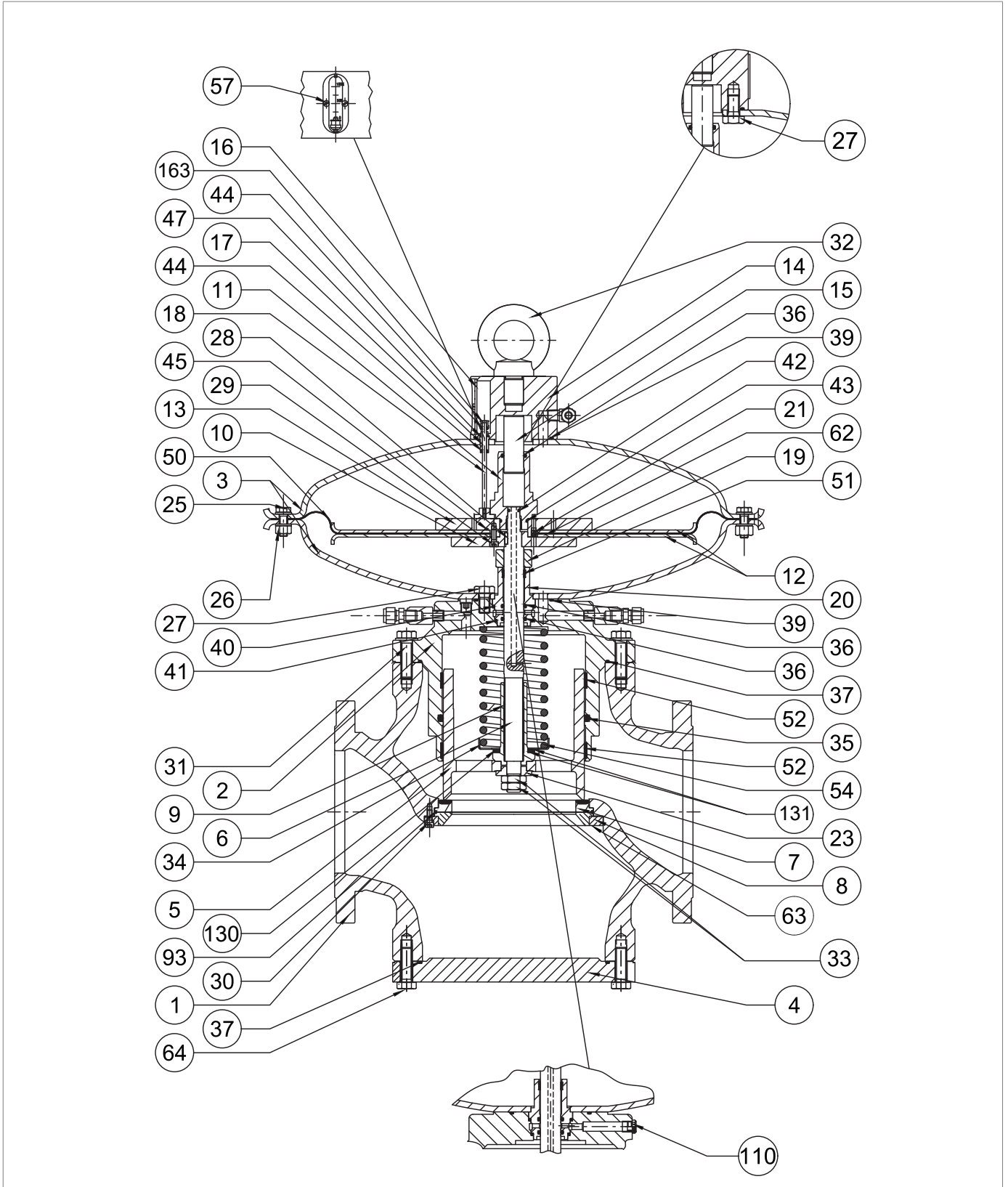

Regulator REVAL 182 6" - 8"

Step	Action
59	Clean the plug (5) and the plug guide (2) lubricating with silicone grease.
60	Insert the plug (5).
61	Insert the washer (23).
62	<p>Insert and secure the locking nuts (33), applying threadlocking glue, according to the tightening torque:</p> <ul style="list-style-type: none"> • 6": Tab. 9.95 • 8": Tab. 9.96 <p>NOTICE!</p> <p>During this phase, manually compress the spring (54).</p>
63	Undo and remove the screws (64).
64	<p>Remove the blind flange (4).</p> <p>NOTICE!</p> <p>During this step, support the blind flange (4).</p>
65	<p>Remove the O-ring (37) and replace it, lubricating it with synthetic grease.</p> <p>NOTICE!</p> <p>Before inserting the replacement O-ring, clean the retaining slots with a cleaning solution.</p>
66	<p>Unscrew and remove screws (30), shaft collar (8), reinforced gaskets (7, 63) and O-ring (93).</p> <p>NOTICE!</p> <ul style="list-style-type: none"> • Take care that the upper seal does not fall off. • If the SB/82 slam-shut valve is fitted, the conical seat replaces the reinforced gasket (63).
67	<p>Remove the O-ring (93) from the reinforced gasket (7) and replace it, lubricating it with synthetic grease.</p> <p>NOTICE!</p> <p>Before inserting the replacement O-ring, clean the retaining slots with a cleaning solution.</p>
68	Clean the upper and lower supporting surfaces of the body, the flanges, the contact surfaces between the reinforced gasket (7) and the regulator body (1), and between the reinforced gasket (63) and the regulator body (1).
69	<p>Position the reinforced gaskets (7, 63) and the shaft collar (8).</p> <p>NOTICE!</p> <p>If the SB/82 slam-shut valve is fitted, the conical seat replaces the reinforced gasket (63).</p>
70	<p>Insert and fix the screws (30) according to the following tightening torque:</p> <ul style="list-style-type: none"> • 6": Tab. 9.95 • 8": Tab. 9.96 <p>NOTICE!</p> <p>Tighten the screws according to the cross diagram in paragraph 9.4.2.2.</p>
71	<p>Fit the flange (4).</p> <p>NOTICE!</p> <p>During this step, support the blind flange (4).</p>

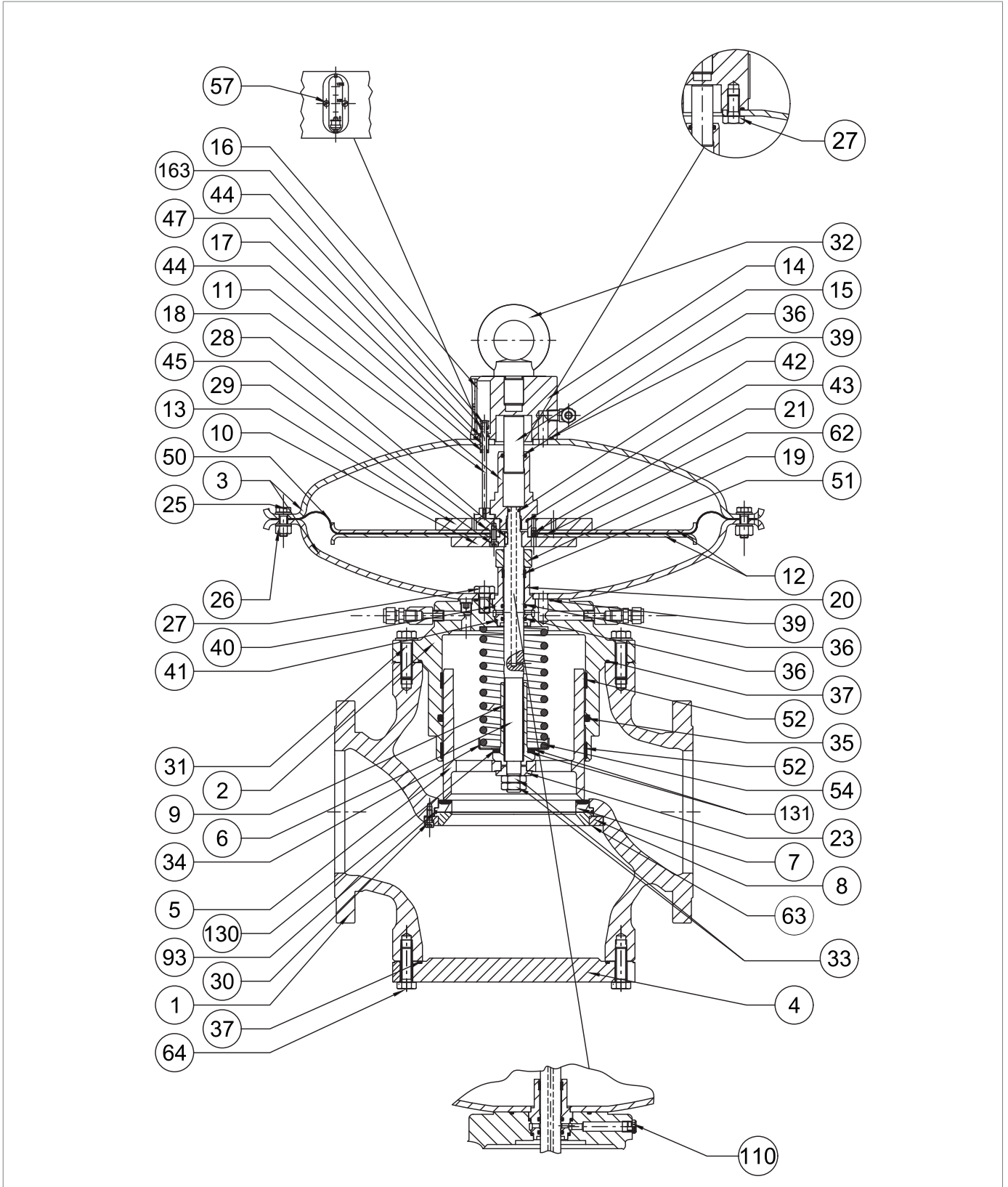

Regulator REVAL 182 6" - 8"

Step	Action
72	<p>Insert and fix the screws (64) according to the following tightening torque:</p> <ul style="list-style-type: none"> • 6": Tab. 9.95 • 8": Tab. 9.96 <p>NOTICE!</p> <p>Tighten the screws according to the cross diagram in paragraph 9.4.2.2.</p>
73	<p>Position the control head inside the regulator housing (1) with the indicator slide (16) visible and parallel to the gas flow.</p> <p>NOTICE!</p> <p>Take care not to damage the plug profile (2).</p>
74	<p>Insert and fix the screws (31) according to the following tightening torque:</p> <ul style="list-style-type: none"> • 6": Tab. 9.95 • 8": Tab. 9.96 <p>NOTICE!</p> <p>Tighten the screws according to the cross diagram in paragraph 9.4.2.2.</p>
75	<p>Insert the pawl (163) into the indicator rod (18).</p> <p>NOTICE!</p> <p>Check that the pawl (163) is in position 0% in relation to the indicator slide (16).</p>
76	Insert the indicator slide (16) into the eyebolt flange (14).
77	Insert and fasten the screws (57).
78	Connect the pneumatic connections between the regulator and the respective control unit, including downstream pressure ports.

Tab. 9.148.

WARNING!

Ensure that all parts have been fitted correctly.

9.4.3.4 - REGULATOR REVAL 182 10"

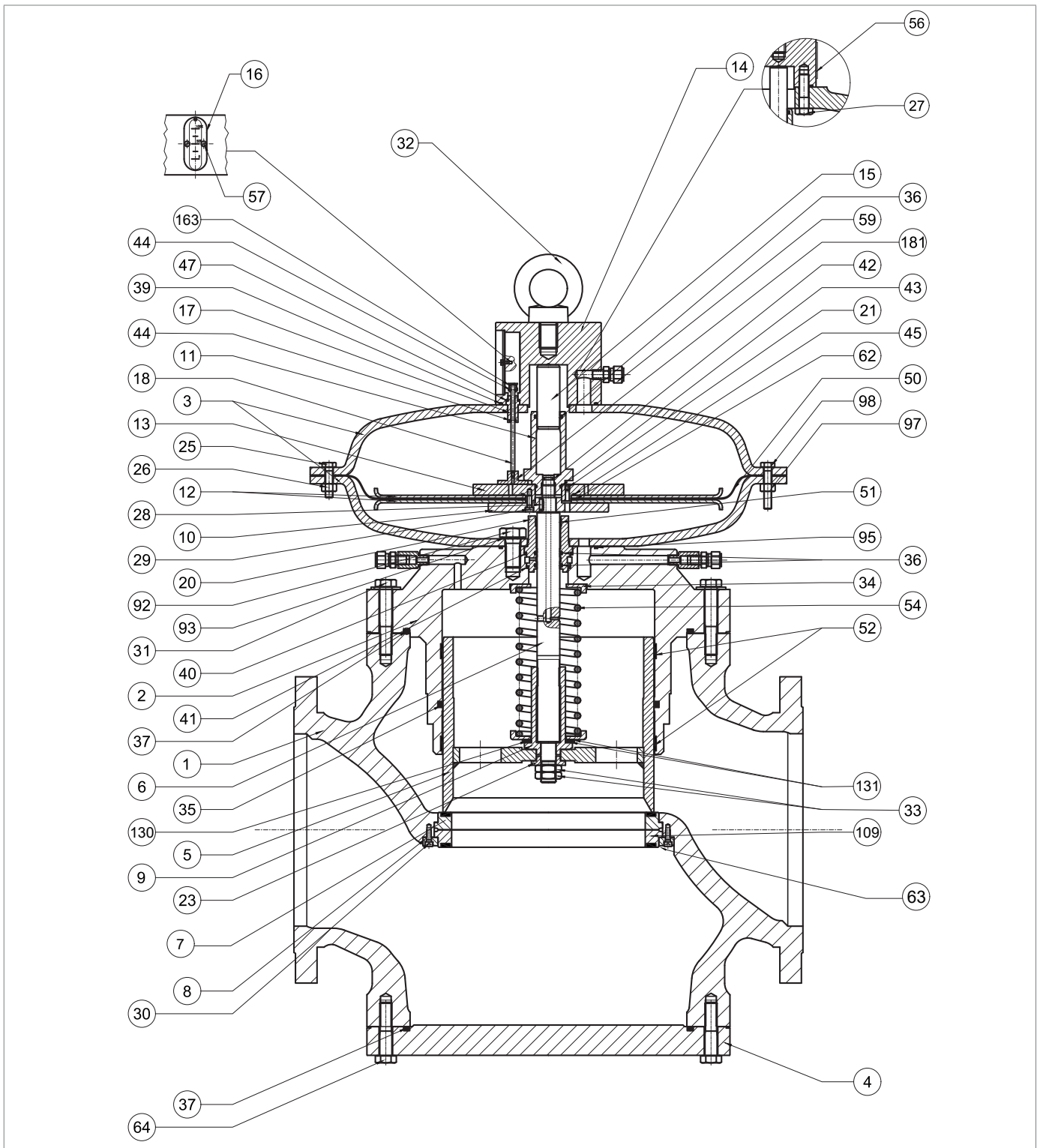
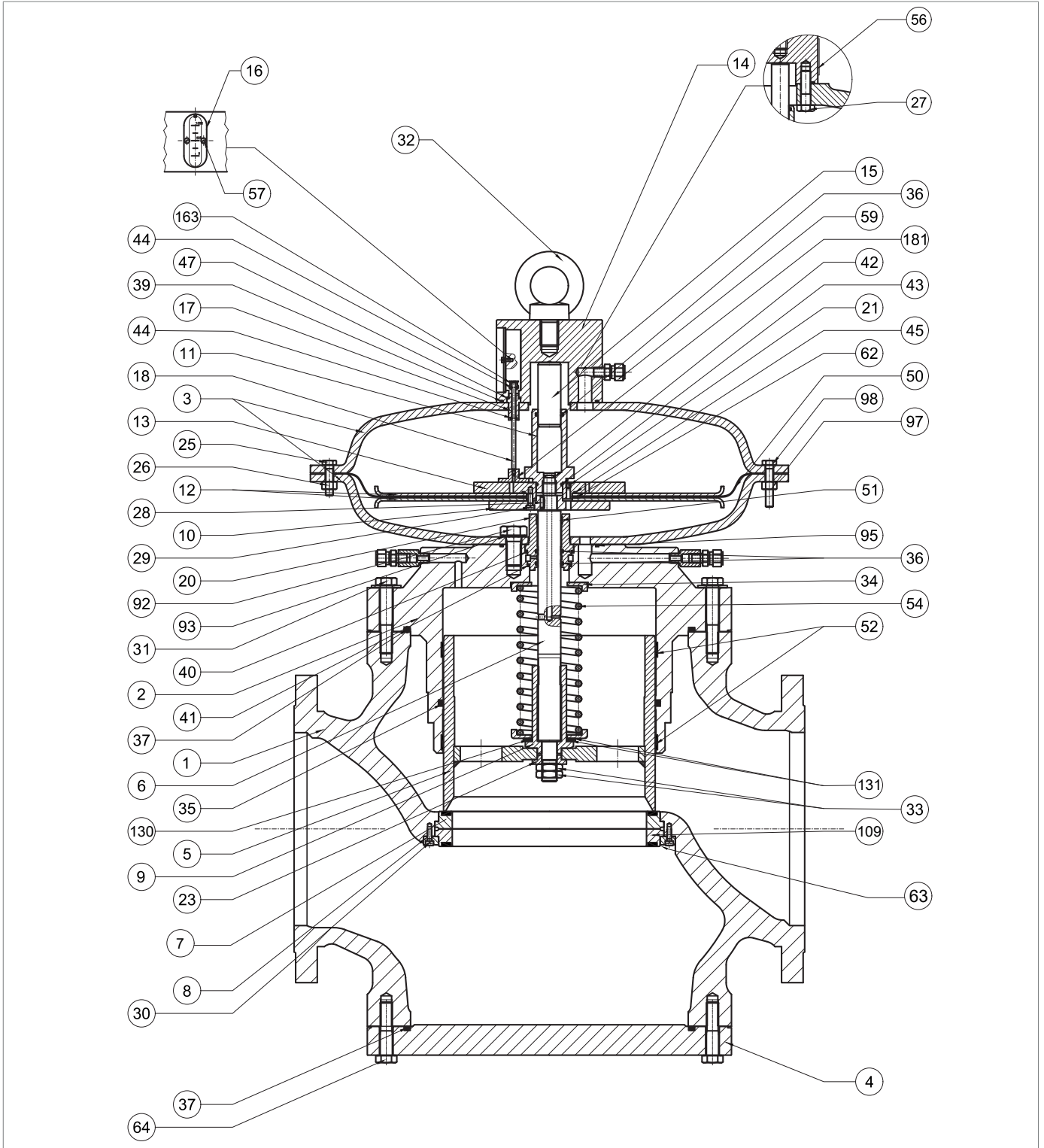

Fig. 9.72. Regulator REVAL 182 10"

Step	Action
1	<p>Unscrew and remove the screws on the upper part (31) which secure the control head to the regulator body (1).</p> <p>! NOTICE!</p> <p>Support the head assembly during this step to avoid falls.</p>
2	<p>Remove the control head and place it on its side in a plane with an impact-resistant surface.</p> <p>! NOTICE!</p> <p>Take care not to damage the plug profile (5).</p>
3	<p>Remove the O-ring (37) from the plug guide (2) and replace it, lubricating it with synthetic grease.</p> <p>! NOTICE!</p> <p>Before inserting the replacement O-ring, clean the retaining slots with a cleaning solution.</p>
4	Unscrew and remove the nuts (33) together with the washer (23).
5	Remove the plug (5) and place it on an anti-shock surface.
6	<p>Unscrew the locking nut (9) to release the spring.</p> <p>! NOTICE!</p> <p>Take care not to damage the plug profile (5).</p>
7	Remove the washers (131) and radial bearings (130).
8	Remove spring supports (34) and spring (54).
9	<p>Remove and replace the I/DWR rings (52) from the plug guide (2).</p> <p>! NOTICE!</p> <p>Before inserting the replacement I/DWR rings, clean the retaining slots with a cleaning solution.</p>
10	<p>Remove the O-ring (35) from the plug guide (2) and replace it, lubricating it with synthetic grease.</p> <p>! NOTICE!</p> <p>Before inserting the replacement O-ring, clean the retaining slots with a cleaning solution.</p>
11	Clean the plug (5) and the plug guide (2) lubricating with silicone grease.
12	Unscrew and remove the nuts (26, 97) together with the screws (25, 98).
13	Remove the upper lid (3).
14	Remove the indicator rod (18) from the rod guide (17).
15	Unscrew and remove the top screws (27) from the top cover (3).
16	Separate the upper cover (3) from the eyebolt flange (14).
17	Take out the rod guide (17).
18	<p>Remove the O-rings (39, 47) from the eyebolt flange (14) and replace them, lubricating them with synthetic grease.</p> <p>! NOTICE!</p> <p>Before inserting the replacement O-ring, clean the retaining slots with a cleaning solution.</p>



Regulator REVAL 182 10"

Step	Action
19	Remove the O-ring (44) from the rod guide (17) and replace it, lubricating it with synthetic grease. NOTICE! Before inserting the replacement O-ring, clean the retaining slots with a cleaning solution.
20	Unscrew and remove the position screws (57) together with the indicator glass (16) and pawl (163).
21	Remove and replace the O-ring (44) from the pawl (163), lubricating it with synthetic grease. NOTICE! Before inserting the replacement O-ring, clean the retaining slots with a cleaning solution.
22	Place the rod guide (17) in the eyebolt flange (14).
23	Assemble the eyebolt flange (14) with the upper lid (3).
24	Insert and fasten the screws of the upper part (27) in the upper cover (3) according to the tightening torque: • 10": Tab. 9.97 NOTICE! Tighten the screws according to the cross diagram in paragraph 9.4.2.2.
25	Insert the indicator rod (18) into the rod guide (17).
26	Unscrew and remove the balancing stem guide (11). NOTICE! In this step, keep the diaphragm unit still, fitting the compass wrench into the holes in the upper diaphragm support (13).
27	Remove the balancing piston (15) from the balancing stem guide (11).
28	Remove and replace the O-rings (36, 43) from the balancing stem guide (11), lubricating them with synthetic grease. NOTICE! Before inserting the replacement O-rings, clean the retaining slots with a cleaning solution.
29	Position the balancing piston (15) in the balancing stem guide (11).
30	Take out the diaphragm unit (10, 12, 13, 21, 29, 45, 50, 62)
31	Undo and remove the screws (29) from the lower diaphragm support (10).
32	Remove the diaphragm support (10) and the lower diaphragm protection disc (12).
33	Remove and replace the diaphragm (50) together with the oil seal (62).
34	Remove the upper diaphragm support (13) from the lower diaphragm protection disc (12).
35	Remove and replace the O-ring (45) from the upper diaphragm support (13), lubricating it with synthetic grease. NOTICE! Before inserting the replacement O-ring, clean the retaining slots with a cleaning solution.

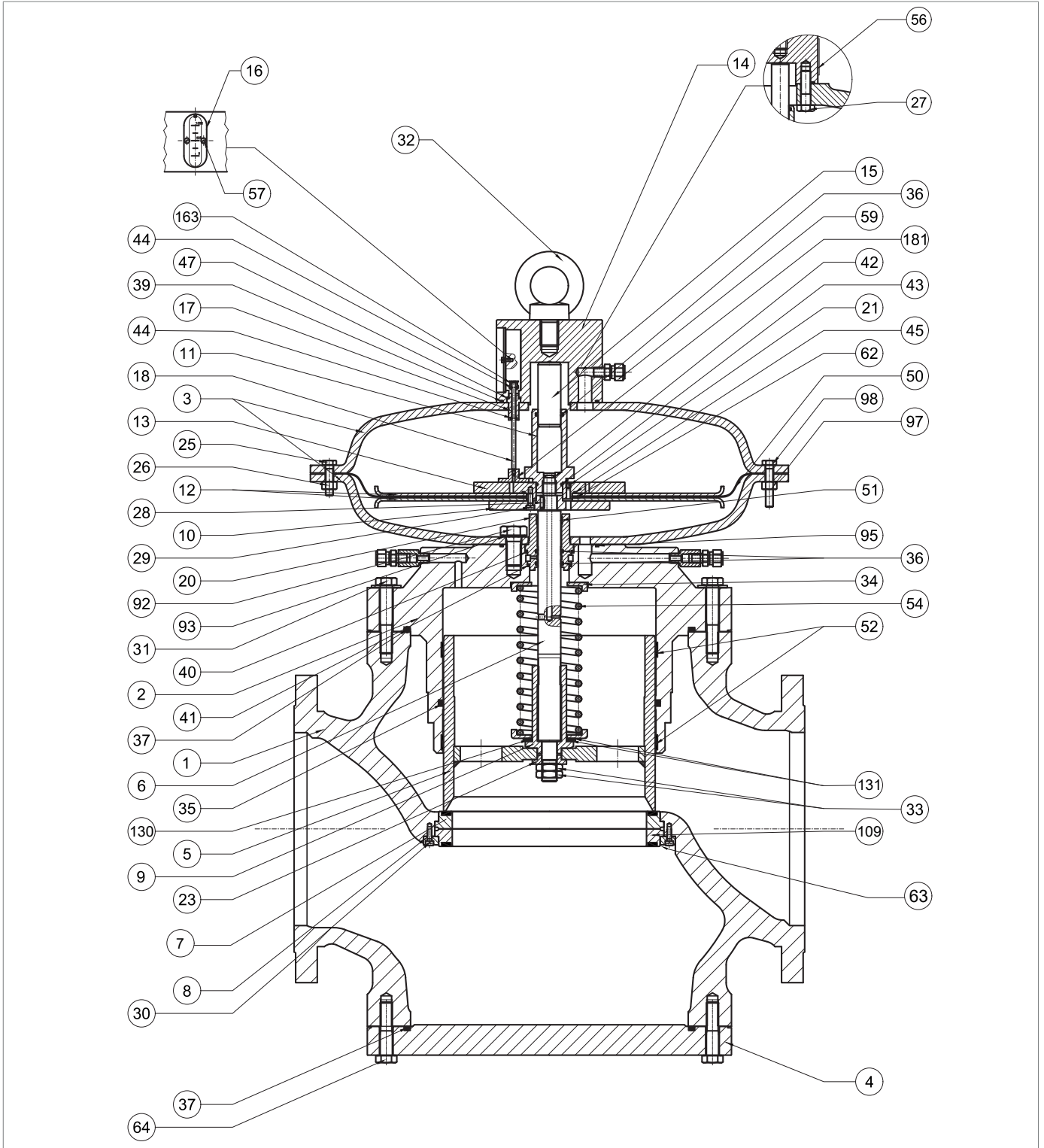

Regulator REVAL 182 10"

Step	Action
36	<p>Put the upper diaphragm support (13) back in place into the upper diaphragm protection disc (12).</p> <p>! NOTICE!</p> <p>Check that the hole on the nozzle (21) is free from dirt or foreign bodies.</p>
37	<p>Position the diaphragm (50).</p> <p>! NOTICE!</p> <p>The concave part of the diaphragm must face the drive chamber (pos. B, fig. 4.2).</p>
38	<p>Position the oil seal (62).</p>
39	<p>Put the diaphragm protection disc (12) and the lower diaphragm support (10) in place.</p> <p>! NOTICE!</p> <p>Check that the nozzle hole on the upper diaphragm support (13) is aligned with the hole on the lower diaphragm support (10).</p>
40	<p>Apply thread locking glue to insert and fix the screws (29) according to the following tightening torque:</p> <ul style="list-style-type: none"> 10": Tab. 9.97 <p>! NOTICE!</p> <p>Tighten the screws according to the cross diagram in paragraph 9.4.2.2.</p>
41	<p>Unscrew and remove the screws of the lower part (92) of the lower cover (4).</p>
42	<p>Remove the upper cover (4).</p>
43	<p>Remove the O-ring (95) from the plug guide (2) and replace it, lubricating it with synthetic grease.</p> <p>! NOTICE!</p> <p>Before inserting the replacement O-ring, clean the retaining slots with a cleaning solution.</p>
44	<p>Remove the stem guide (20), the stem (6) and the key (28).</p>
45	<p>Remove and replace the I/DWR rings (51) from the stem guide (20).</p> <p>! NOTICE!</p> <p>Before inserting the replacement I/DWR ring, clean the retaining slots with a cleaning solution.</p>
46	<p>Remove the O-rings (36) from the stem guide (20) and replace them, lubricating them with synthetic grease.</p> <p>! NOTICE!</p> <p>Before inserting the replacement O-ring, clean the retaining slots with a cleaning solution.</p>
47	<p>Remove the O-rings (40, 41) from the stem guide (20) and replace them, lubricating them with synthetic grease.</p> <p>! NOTICE!</p> <p>Before inserting the replacement O-rings, clean the retaining slots with a cleaning solution.</p>

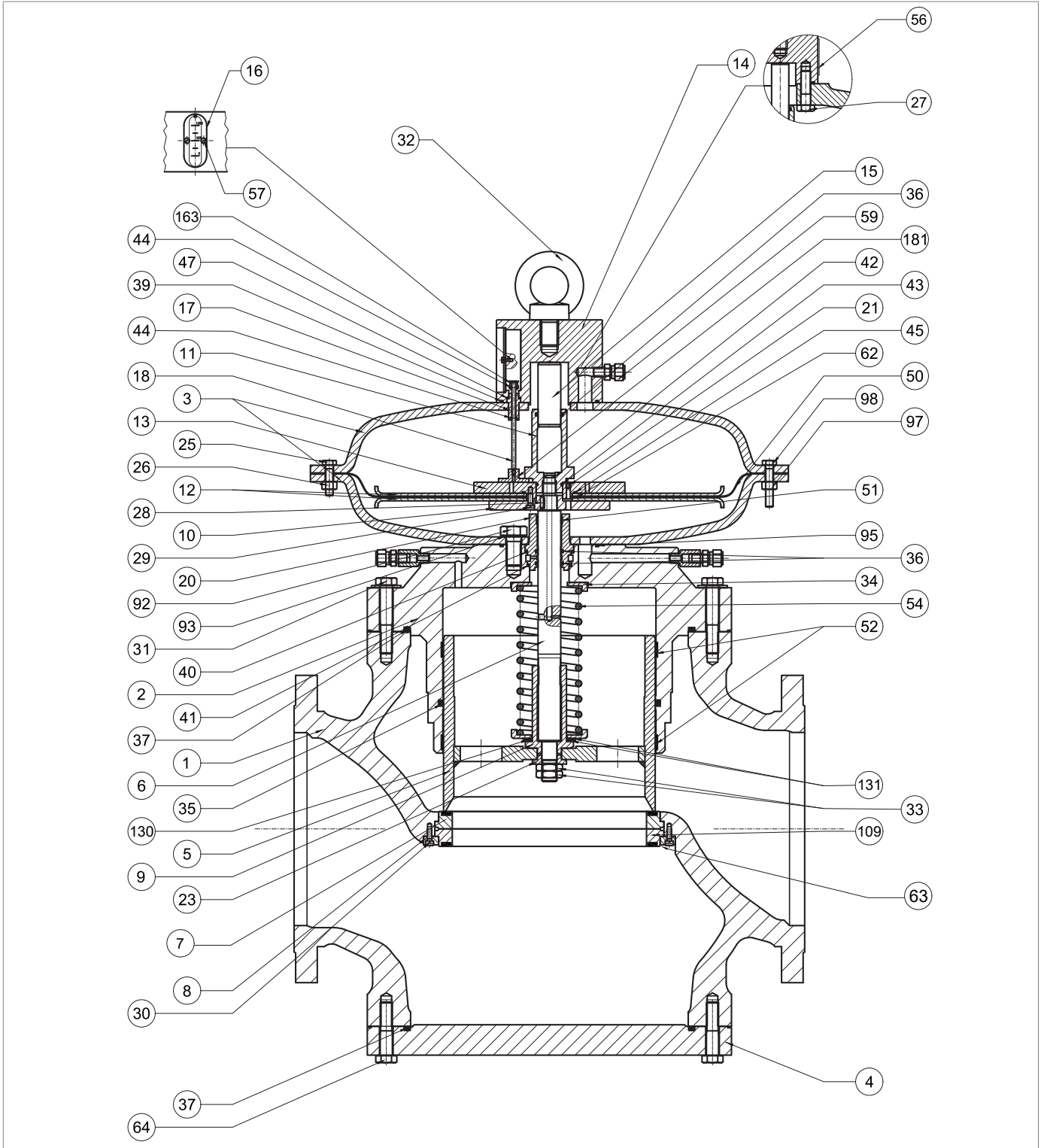

Regulator REVAL 182 10"

Step	Action
48	<p>Remove the O-ring (42) from the stem (6) and replace it, lubricating it with synthetic grease.</p> <p>! NOTICE!</p> <p>Before inserting the replacement O-ring, clean the retaining slots with a cleaning solution.</p>
49	<p>Remove the stem guide (20), the stem (6) and the key (28).</p> <p>! NOTICE!</p> <ul style="list-style-type: none"> • Lubricate the stem surface with silicone grease • The key (28) must be in the correct position in the stem (6)
50	<p>Put the lower cover (4) in place and fix it on the plug guide (2).</p> <p>! NOTICE!</p> <p>The hole for the passage of the loading pressure must match the similar one on the plug guide.</p>
51	<p>Insert and fix the screws of the lower section (92) according to the following tightening torque:</p> <ul style="list-style-type: none"> • 10": Tab. 9.97 <p>! NOTICE!</p> <p>Tighten the screws according to the cross diagram in paragraph 9.4.2.2.</p>
52	<p>Put the diaphragm unit in place (10, 12, 13, 21, 29, 45, 50, 62).</p>
53	<p>Insert and secure the balancing stem guide (11) according to the tightening torque:</p> <ul style="list-style-type: none"> • 10": Tab. 9.97 <p>! NOTICE!</p> <p>Hold the diaphragm assembly in place and position the spanner in the holes in the upper diaphragm support (13).</p>
54	<p>Position the upper cover (3), taking care to position the indicator stem (18) in the space between the upper diaphragm support (13) and the balance stem guide (11).</p> <p>! NOTICE!</p> <ul style="list-style-type: none"> • The indicator rod (18) must not obstruct the hole on the upper diaphragm support (13); • The flange travel indicator must be visible and perpendicular to the gas flow
55	<p>Place the pilot support screw (98).</p>
56	<p>Insert and fasten the screws (25) with the nuts (26) according to the tightening torque:</p> <ul style="list-style-type: none"> • 10": Tab. 9.97 <p>! NOTICE!</p> <p>Tighten the screws according to the cross diagram in paragraph 9.4.2.2.</p>
57	<p>Position the spring (54) and spring supports (34).</p>
58	<p>Insert radial bearing (131) and washer (130).</p>
59	<p>Insert the locking nut (9) according to the tightening torque:</p> <ul style="list-style-type: none"> • 10": Tab. 9.97 <p>! NOTICE!</p> <p>Check that the spring (54) is properly seated in the centring stop on the plug guide (2).</p>

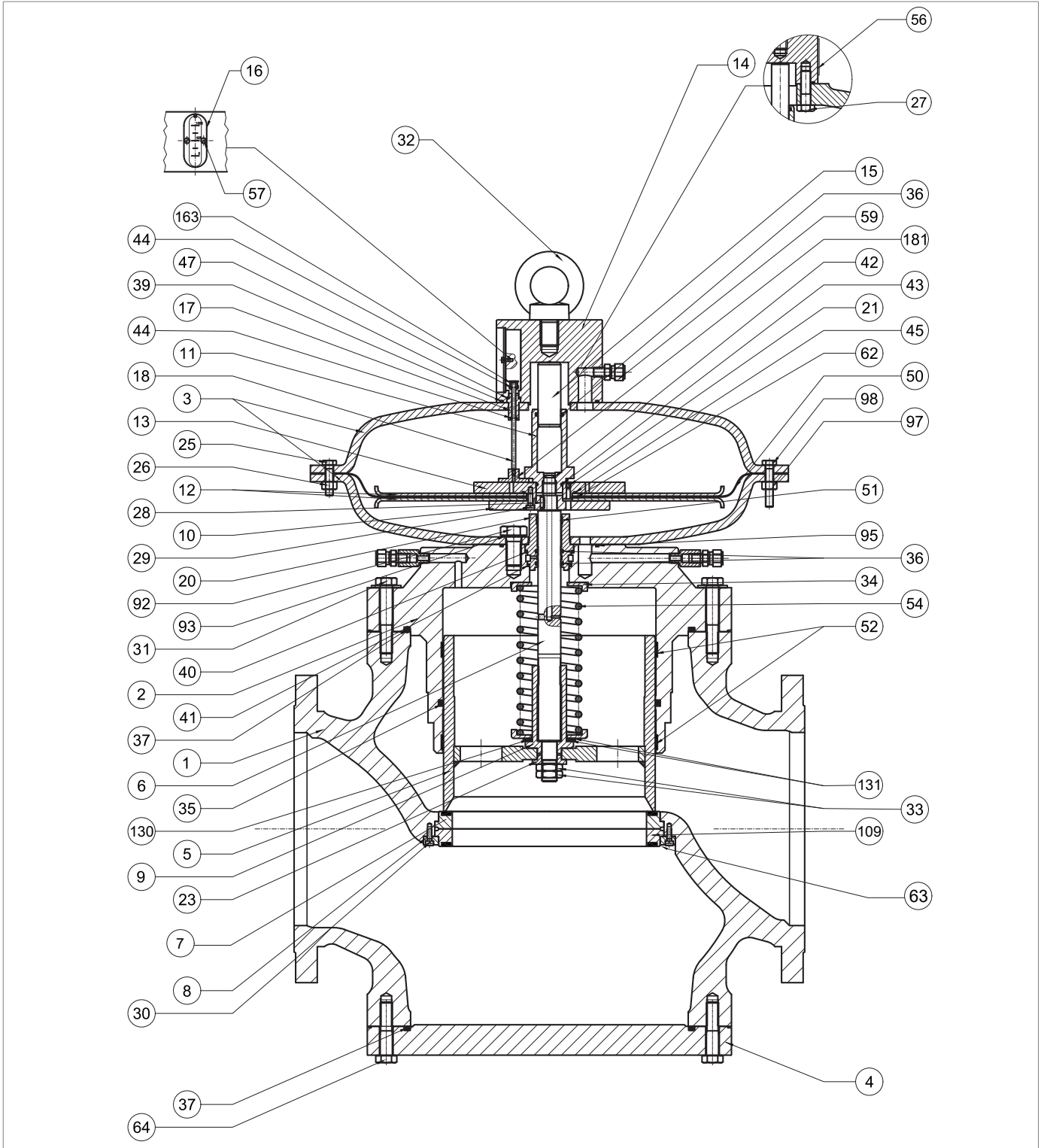

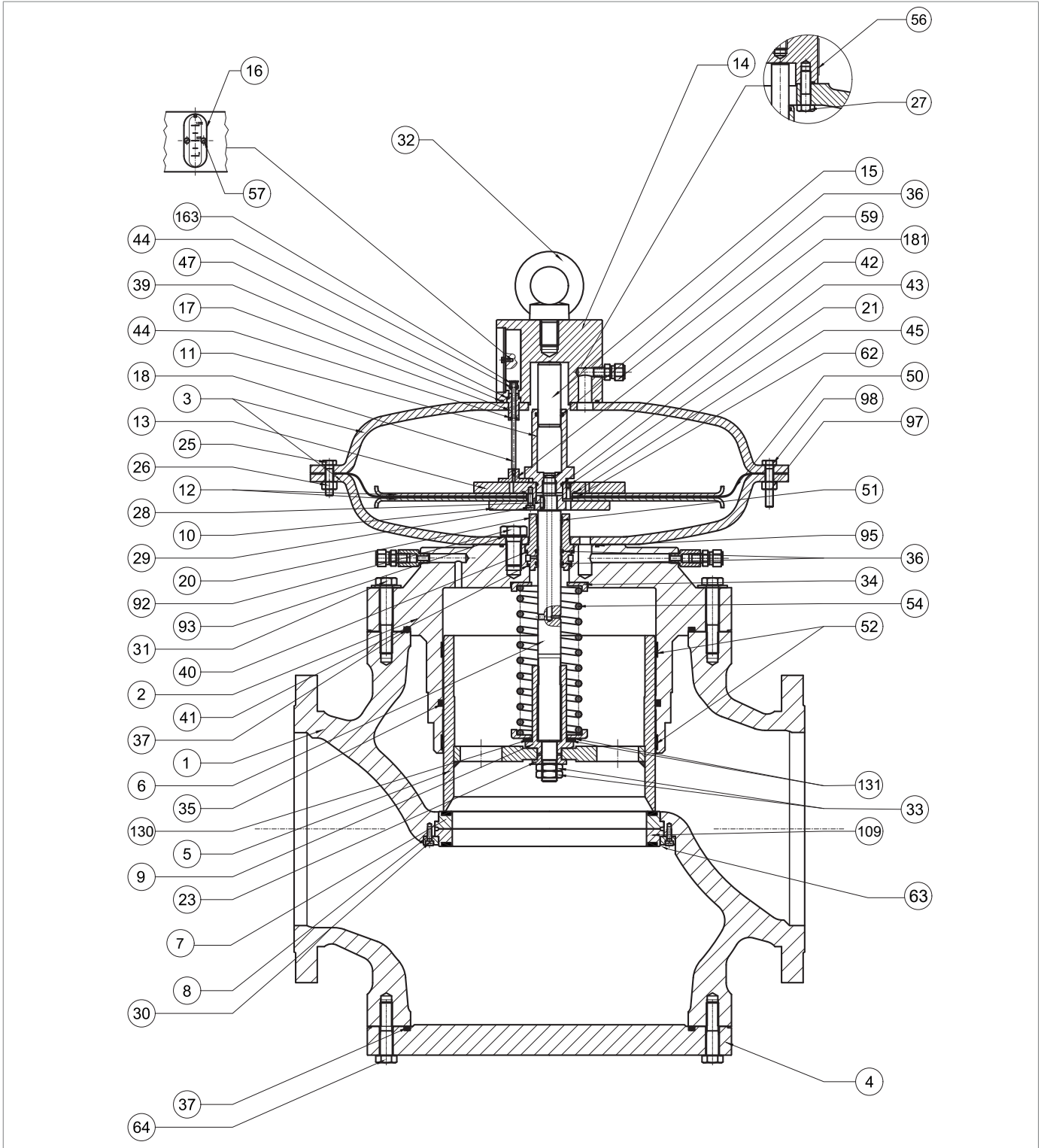

Regulator REVAL 182 10"

Step	Action
60	Insert the plug (5).
61	Insert the washer (23).
62	<p>Insert and secure the locking nuts (33), applying threadlocking glue, according to the tightening torque:</p> <ul style="list-style-type: none"> • 10": Tab. 9.97 <div style="border: 1px solid black; padding: 5px;"> <p>! NOTICE!</p> <p>Tighten the screws according to the cross diagram in paragraph 9.4.2.2.</p> </div>
63	Undo and remove the screws (64).
64	Remove the blind flange (4), taking care to support it.
65	<p>Remove the O-ring (37) and replace it, lubricating it with synthetic grease.</p> <div style="border: 1px solid black; padding: 5px;"> <p>! NOTICE!</p> <p>Before inserting the replacement O-ring, clean the retaining slots with a cleaning solution.</p> </div>
66	<p>Unscrew and remove screws (30), shaft collar (8), reinforced gaskets (7, 109) and O-ring (93).</p> <div style="border: 1px solid black; padding: 5px;"> <p>! NOTICE!</p> <ul style="list-style-type: none"> • Take care that the upper seal does not fall off. • If the SB/82 slam-shut valve is fitted, the conical seat replaces the reinforced gasket (109). </div>
67	<p>Remove the O-ring (93) from the reinforced gasket (7, 109) and replace it, lubricating it with synthetic grease.</p> <div style="border: 1px solid black; padding: 5px;"> <p>! NOTICE!</p> <p>Before inserting the replacement O-ring, clean the retaining slots with a cleaning solution.</p> </div>
68	Clean the upper and lower supporting surfaces of the body, the flanges, the contact surfaces between the reinforced gasket (7) and the regulator body (1), and between the reinforced gasket (109) and the body (1).
69	<p>Place the reinforced gasket (7, 109) and the shaft collar (8).</p> <div style="border: 1px solid black; padding: 5px;"> <p>! NOTICE!</p> <p>If the SB/82 slam-shut valve is fitted, the conical seat replaces the reinforced gasket (109).</p> </div>
70	<p>Insert and fix the screws (30) according to the following tightening torque:</p> <ul style="list-style-type: none"> • 10": Tab. 9.97 <div style="border: 1px solid black; padding: 5px;"> <p>! NOTICE!</p> <p>Tighten the screws according to the cross diagram in paragraph 9.4.2.2.</p> </div>
71	Position the blind flange (4), taking care to support it.
72	<p>Insert and fix the screws (64) according to the following tightening torque:</p> <ul style="list-style-type: none"> • 10": Tab. 9.97 <div style="border: 1px solid black; padding: 5px;"> <p>! NOTICE!</p> <p>Tighten the screws according to the cross diagram in paragraph 9.4.2.2.</p> </div>
73	<p>Position the control head inside the regulator body (1) with the indicator slide (16) visible and on axis with the gas flow direction.</p> <div style="border: 1px solid black; padding: 5px;"> <p>! NOTICE!</p> <p>Take care not to damage the plug profile (5).</p> </div>



Regulator REVAL 182 10"

Step	Action
74	Insert and fix the screws (31) according to the following tightening torque: <ul style="list-style-type: none"> • 10^m: Tab. 9.97 <div style="border: 1px solid black; padding: 5px;">  NOTICE! Tighten the screws according to the cross diagram in paragraph 9.4.2.2. </div>
75	Insert the pawl (163) into the rod (18).
76	Place the indicator slide (16) in the eyebolt flange (14). <div style="border: 1px solid black; padding: 5px;">  NOTICE! Check that the pawl (163) is in position 0% in relation to the indicator slide (16). </div>
77	Insert and fasten the screws (57).
78	Connect the pneumatic connections between the regulator and the respective control unit, including downstream pressure ports.

Tab. 9.149.

 **WARNING!**
Ensure that all parts have been fitted correctly.

9.4.4 - SILENCER MAINTENANCE DB/182

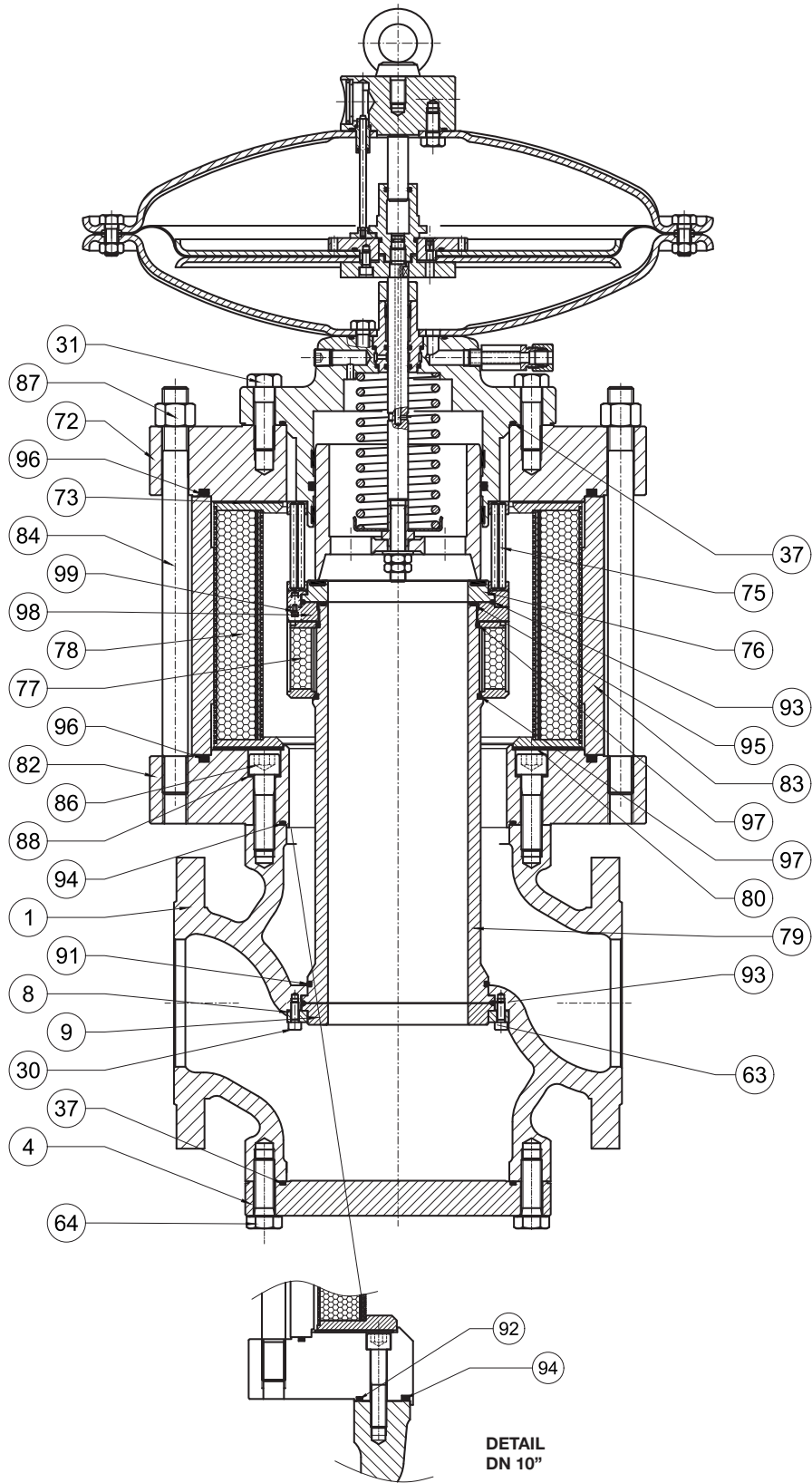
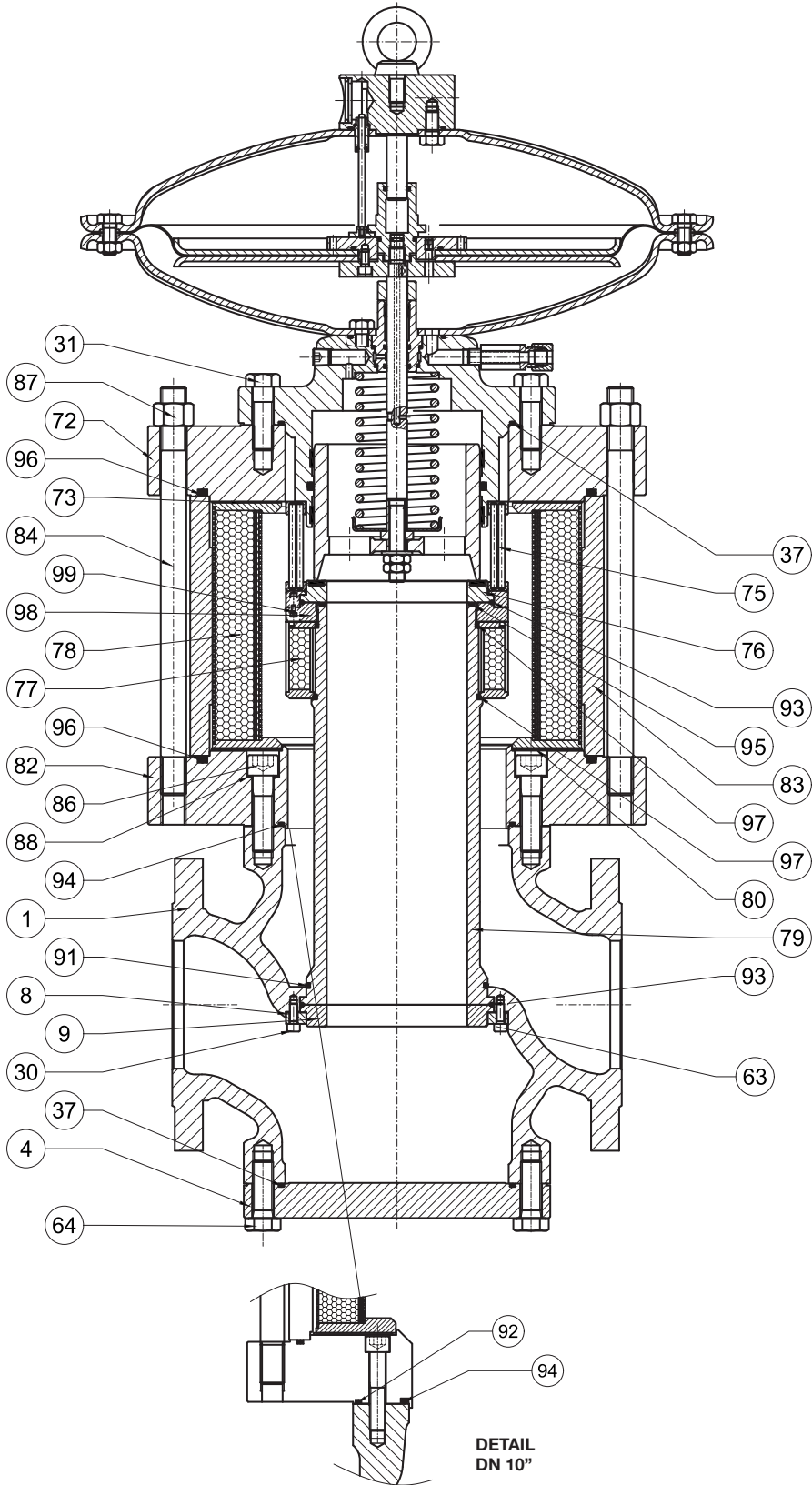

Fig. 9.73. DB/182 Silencer

Step	Action
1	<p>Unscrew and remove the upper part screws (31) that secure the control head to the upper flange (72) of the silencer</p> <p>! NOTICE!</p> <p>Support the head assembly during this step to avoid falls.</p>
2	<p>Remove the control head and place it on its side in a plane with an impact-resistant surface.</p> <p>! NOTICE!</p> <p>Take care not to damage the plug profile (5).</p>
3	<p>Unscrew and remove the grid assembly (76, 93, 98, 99).</p> <p>! NOTICE!</p> <p>To do so, use tool ref.O, tab.48 of paragraph 7.1 "List of equipment".</p>
4	Unscrew and remove the nuts (87).
5	Remove the upper flange (72).
6	<p>Remove the O-ring (96) from the upper flange (72) and replace it, lubricating it with synthetic grease.</p> <p>! NOTICE!</p> <p>Before inserting the replacement O-ring, clean the retaining slots with a cleaning solution.</p>
7	Remove the upper anti-oil gasket (73).
8	Remove the external basket (78).
9	Remove the plating (83).
10	Remove the internal silencer (77).
11	<p>Remove the O-ring (95) from the sleeve (79) and replace it, lubricating it with synthetic grease.</p> <p>! NOTICE!</p> <p>Before inserting the replacement O-ring, clean the retaining slots with a cleaning solution.</p>
12	Remove and replace the lower anti-oil gasket (80).
13	<p>Remove the O-ring (96) from the lower flange (82) and replace it, lubricating it with synthetic grease.</p> <p>! NOTICE!</p> <p>Before inserting the replacement O-ring, clean the retaining slots with a cleaning solution.</p>
14	<p>VALID ONLY FOR 1" - 8"</p> <p>Undo and remove the screws (86) and the washers (88).</p>
15	<p>ONLY VALID FOR 10"</p> <p>Undo and remove the screws (86).</p>
16	Remove the lower flange (82) together with the tie rods (84).
17	<p>Remove the O-ring (94) from the lower flange (82) and replace it, lubricating it with synthetic grease.</p> <p>! NOTICE!</p> <p>Before inserting the replacement O-ring, clean the retaining slots with a cleaning solution.</p>



DB/182 Silencer

Step	Action
18	<p>ONLY VALID FOR 10" Remove the O-ring (92, 94) from the lower flange (82) and replace it, lubricating it with synthetic grease.</p> <p>NOTICE! Before inserting the replacement O-ring, clean the retaining slots with a cleaning solution.</p>
19	<p>WARNING! Support the flange or any accessory to prevent it from falling</p>
20	Undo and remove the screws (64).
21	Remove the blind flange (4) or any built-in accessory (monitor PM/182 or built-in slam-shut valve SA, SB/82, HB/97).
22	<p>Remove the O-ring (37) from the blind flange (4) and replace it, lubricating it with synthetic grease.</p> <p>NOTICE! Before inserting the replacement O-ring, clean the retaining slots with a cleaning solution.</p>
23	<p>WARNING! Support the sleeve (79) during the next steps to prevent it from falling.</p>
24	<p>Undo and remove the screws (30), the shaft collar (8) and the conical seat (63).</p> <p>NOTICE! As an alternative to the conical seat (63), a reinforced gasket may be installed, based on the built-in accessory.</p>
25	Remove the sleeve (79) from the top downwards.
26	<p>Remove the O-ring (91, 97) from the sleeve (79) and replace it, lubricating it with synthetic grease.</p> <p>NOTICE! Before inserting the replacement O-ring, clean the retaining slots with a cleaning solution.</p>
27	<p>Remove the O-ring (93) from the conical seat (63) and replace it, lubricating it with synthetic grease.</p> <p>NOTICE! Before inserting the replacement O-ring, clean the retaining slots with a cleaning solution.</p>
28	Clean the upper and lower bearing surfaces of the body (1) and the flanges (72, 82), the contact surfaces between the sleeve (79), conical seat (63) and the body.
29	Put the sleeve (79) back in place into the body from the bottom upwards.
30	<p>Put the conical seat (63) back in place together with the O-ring (93) and the shaft collar (8).</p> <p>NOTICE! As an alternative to the conical seat (63), a reinforced gasket may be installed, based on the built-in accessory.</p>

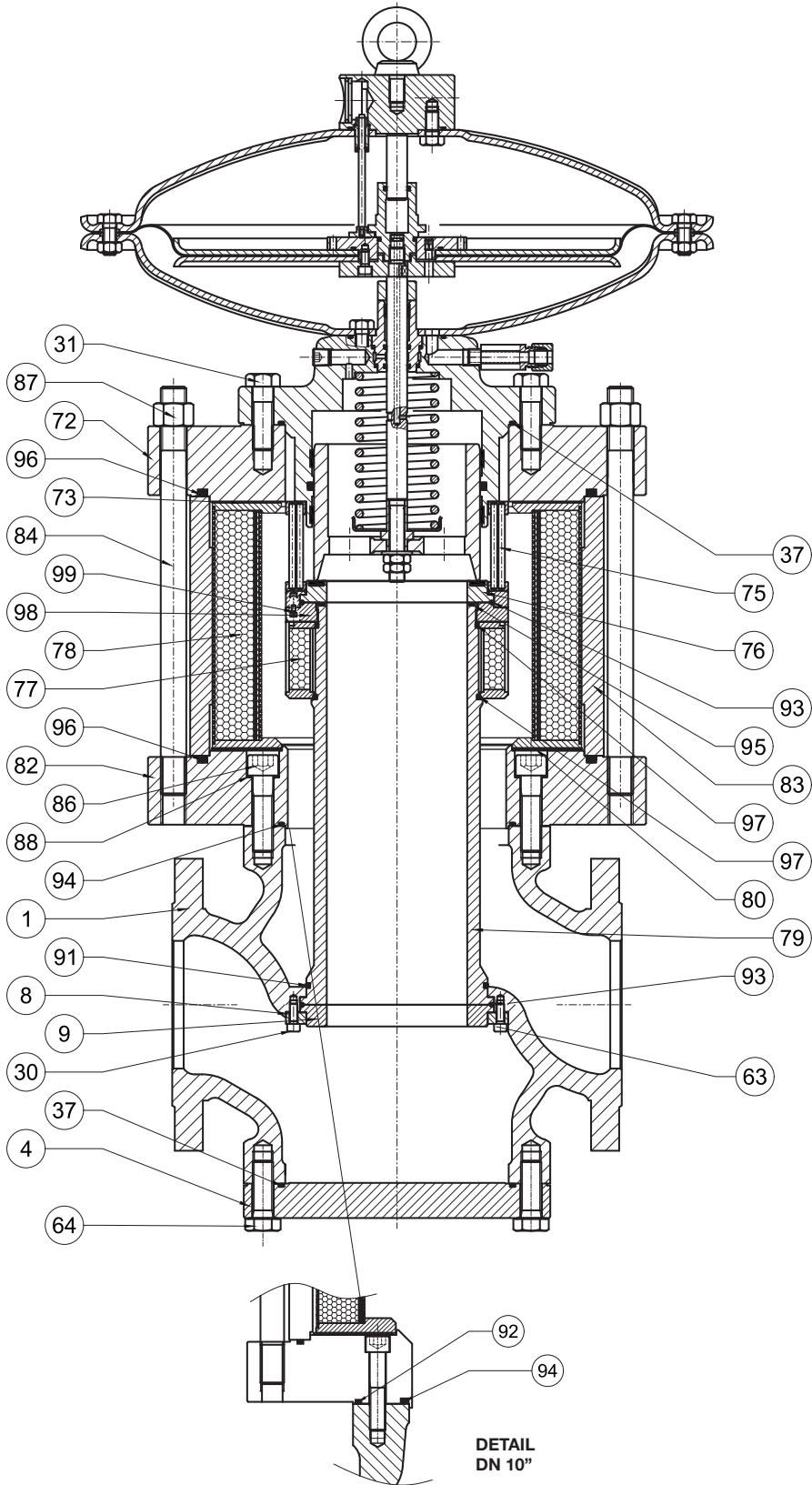



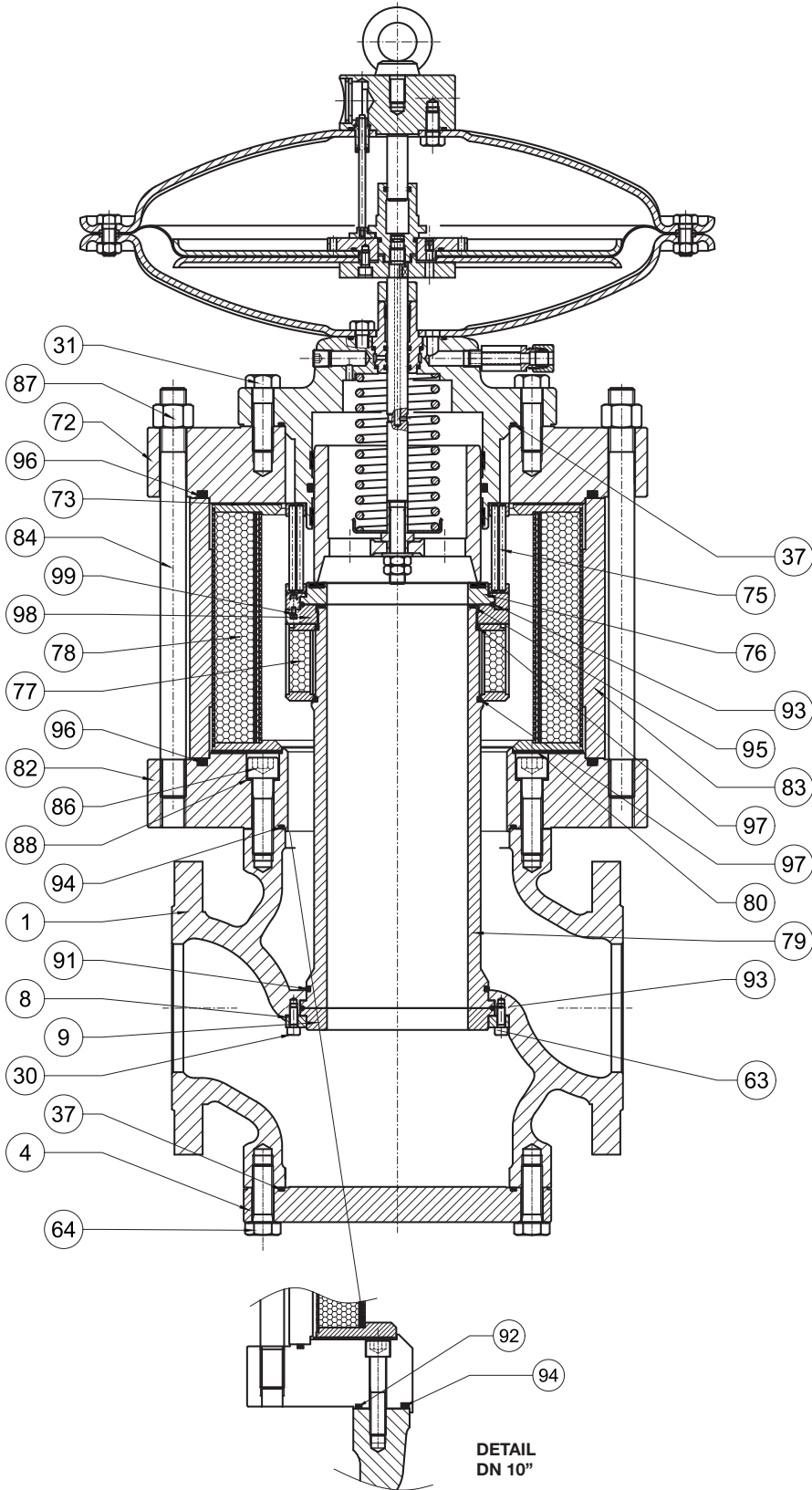

DB/182 Silencer

Step	Action
31	<p>Insert and fix the screws (30) according to the following tightening torques:</p> <ul style="list-style-type: none"> 1": Tab. 9.98 2": Tab. 9.99 2" ½: Tab. 9.100 3": Tab. 9.101 4": Tab. 9.102 6": Tab. 9.103 8": Tab. 9.104 10": Tab. 9.105
	<p>NOTICE!</p> <p>Tighten the screws according to the cross diagram in paragraph 9.4.2.2.</p>
32	<p>WARNING!</p> <p>Support the flange or any accessory to prevent it from falling</p>
33	<p>Position the blind flange (4) or any built-in accessory (monitor PM/182 or built-in slam-shut valve SA, SB/82, HB/97).</p>
34	<p>Insert and fix the screws (31) according to the following tightening torques:</p> <ul style="list-style-type: none"> 1": Tab. 9.98 2": Tab. 9.99 2" ½: Tab. 9.100 3": Tab. 9.101 4": Tab. 9.102 6": Tab. 9.103 8": Tab. 9.104 10": Tab. 9.105
	<p>NOTICE!</p> <p>Tighten the screws according to the cross diagram in paragraph 9.4.2.2.</p>
35	<p>Fit the lower flange (82) together with the tie rods (84).</p>
36	<p>NOTICE!</p> <p>VALID ONLY FOR 1" - 8"</p> <p>Replace the washers (88).</p>
37	<p>Insert and fix the screws (86) according to the following tightening torques:</p> <ul style="list-style-type: none"> 1": Tab. 9.98 2": Tab. 9.99 2" ½: Tab. 9.100 3": Tab. 9.101 4": Tab. 9.102 6": Tab. 9.103 8": Tab. 9.104 10": Tab. 9.105
	<p>NOTICE!</p> <p>Tighten the screws according to the cross diagram in paragraph 9.4.2.2.</p>
38	<p>Fit the lower anti-oil gasket (80).</p>
39	<p>Fit the plating (83).</p>
40	<p>Fit the external basket (78).</p>
41	<p>Fit the internal basket (77).</p>
42	<p>Fit the upper anti-oil gasket (73).</p>
43	<p>Fit the upper flange (72).</p>



DB/182 Silencer

Step	Action
44	Insert and fix the nuts (87) according to the following tightening torques: <ul style="list-style-type: none"> • 1": Tab. 9.98 • 2": Tab. 9.99 • 2" ½: Tab. 9.100 • 3": Tab. 9.101 • 4": Tab. 9.102 • 6": Tab. 9.103 • 8": Tab. 9.104 • 10": Tab. 9.105
	<div style="border: 1px solid black; padding: 5px;">  NOTICE! Tighten the screws according to the cross diagram in paragraph 9.4.2.2. </div>
45	Unscrew and remove the screws (99).
46	Remove the shaft collar nut (98).
47	Remove the O-ring (93) and replace it, taking care to lubricate it with synthetic grease.
	<div style="border: 1px solid black; padding: 5px;">  NOTICE! Before inserting the replacement O-ring, clean the retaining slots with a cleaning solution. </div>
48	Remove and replace the reinforced gasket (76).
	<div style="border: 1px solid black; padding: 5px;">  NOTICE! Before inserting the replacement reinforced gasket, clean the retaining grooves with a cleaning solution. </div>
49	Position the shaft collar nut (98).
50	Insert and fasten the screws (99).
51	Insert and secure the grid assembly (76, 93, 98, 99) to the sleeve (79).
	<div style="border: 1px solid black; padding: 5px;">  NOTICE! To do so, use tool ref.O, tab.7.62 of paragraph 7.1 "List of equipment". </div>
52	Position control header.
53	Insert and fix the nuts (31) according to the following tightening torques: <ul style="list-style-type: none"> • 1": Tab. 9.98 • 2": Tab. 9.99 • 2" ½: Tab. 9.100 • 3": Tab. 9.101 • 4": Tab. 9.102 • 6": Tab. 9.103 • 8": Tab. 9.104 • 10": Tab. 9.105
	<div style="border: 1px solid black; padding: 5px;">  NOTICE! Tighten the screws according to the cross diagram in paragraph 9.4.2.2. </div>

Tab. 9.150.

 **WARNING!**

Ensure that all parts have been fitted correctly.

9.4.5 - PM 182 INCORPORATED MONITOR

9.4.5.1 - PM/182 1" ÷ 2" BUILT-IN MONITOR;

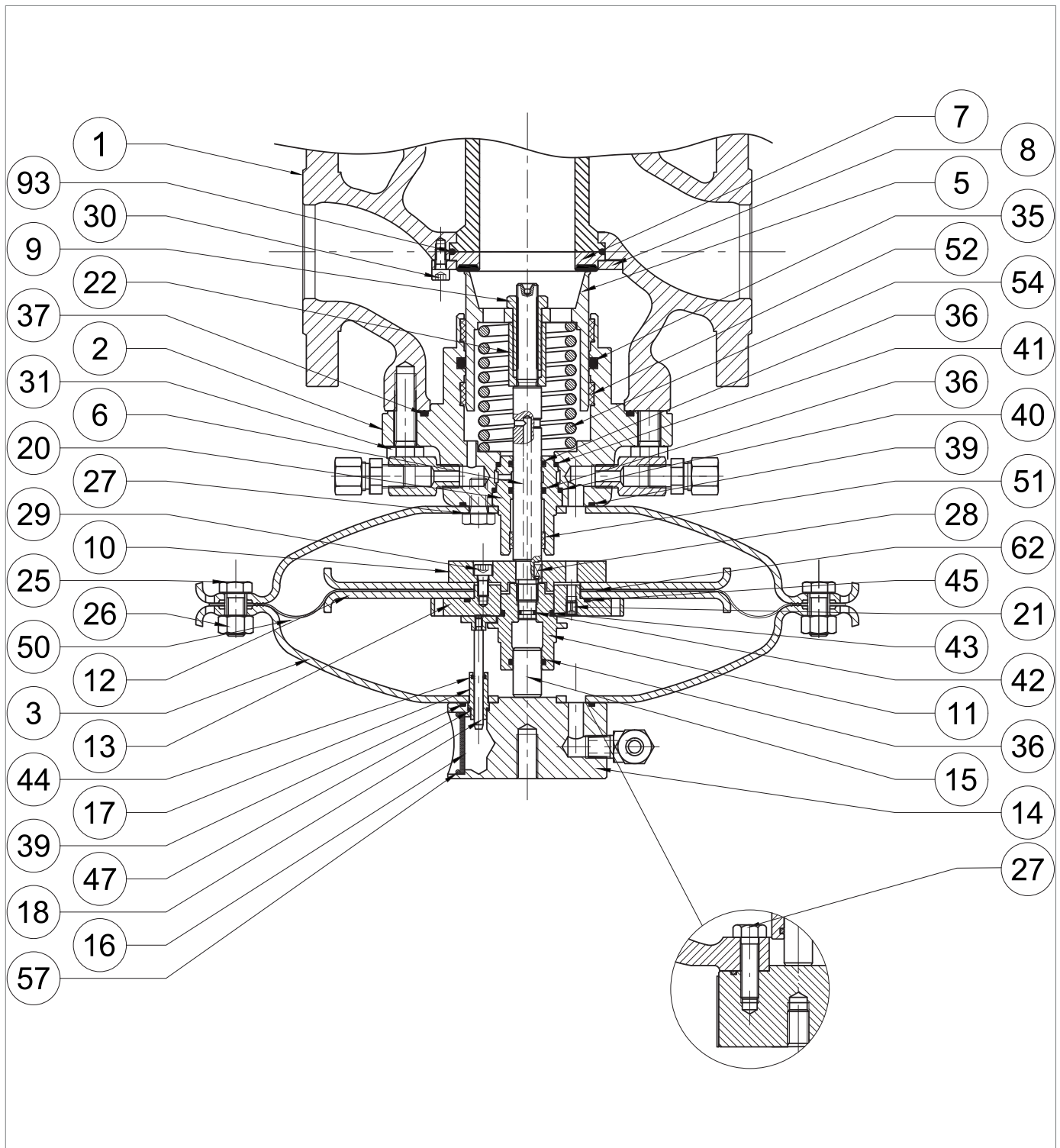
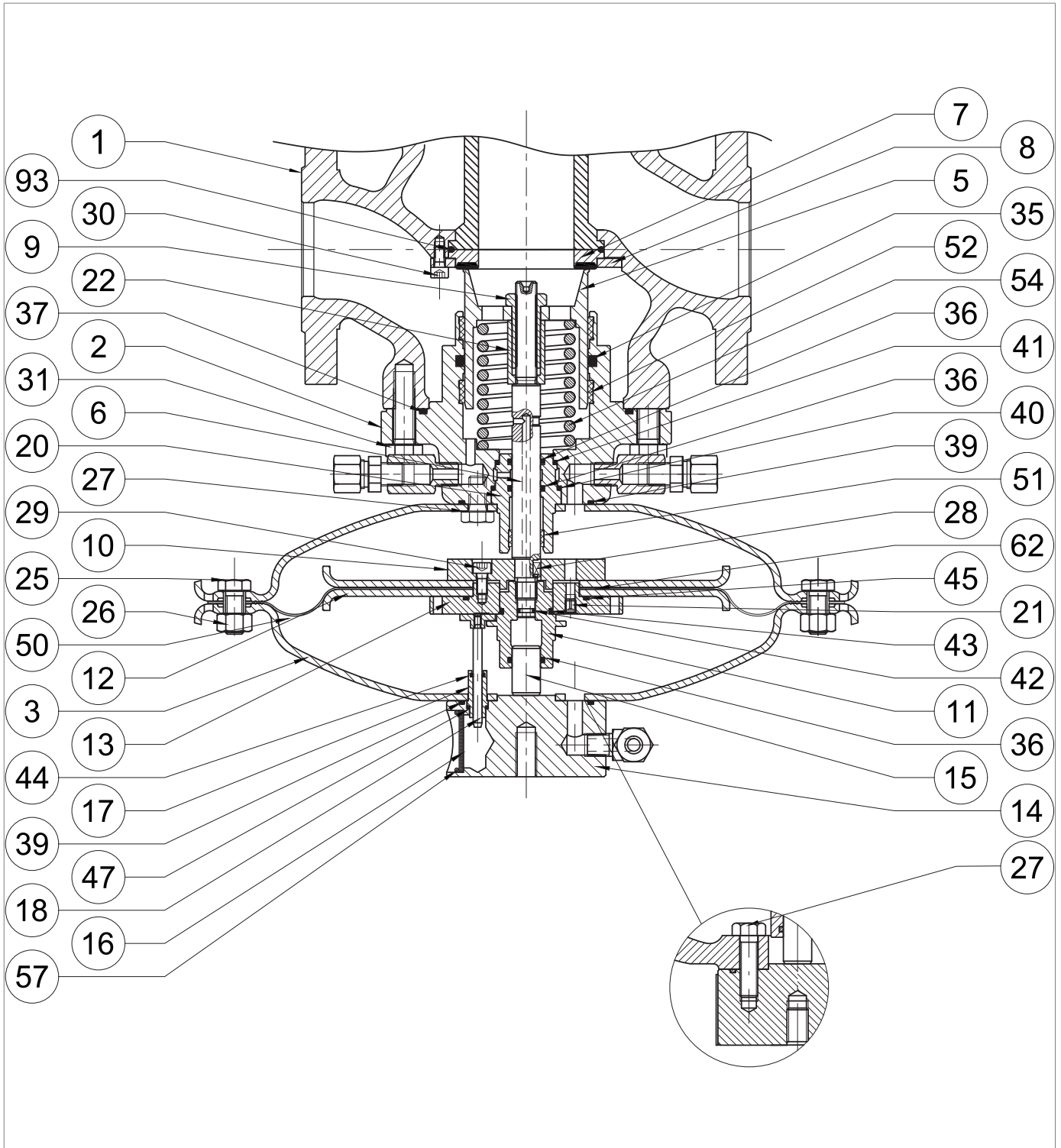

Fig. 9.74. PM/182 1" ÷ 2" built-in monitor;

Step	Action
1	<p>Unscrew and remove the screws (31) securing the control head to the regulator body (1).</p> <p>! NOTICE!</p> <p>Support the head assembly during this step to avoid falls.</p>
2	<p>Remove the control head and place it on its side in a plane with an impact-resistant surface.</p> <p>! NOTICE!</p> <p>Take care not to damage the plug profile (5).</p>
3	<p>Remove the O-ring (37) from the plug guide (2) and replace it, lubricating it with synthetic grease.</p> <p>! NOTICE!</p> <p>Before inserting the replacement O-ring, clean the retaining slots with a cleaning solution.</p>
4	<p>Unscrew the lock nut (9).</p> <p>! NOTICE!</p> <p>Take care not to damage the plug profile (5).</p>
5	Remove the plug (5) and place it on a table with an impact-resistant surface.
6	Remove the spring (54) together with the spacer (22).
7	<p>Remove and replace the I/DWR rings (52) from the plug guide (2).</p> <p>! NOTICE!</p> <p>Before inserting the replacement I/DWR rings, clean the retaining slots with a cleaning solution.</p>
8	<p>Remove the O-ring (35) from the plug guide (2) and replace it, lubricating it with synthetic grease.</p> <p>! NOTICE!</p> <p>Before inserting the replacement O-ring, clean the retaining slots with a cleaning solution.</p>
9	Clean the plug (5) and the plug guide (2) lubricating with silicone grease.
10	Unscrew and remove the nuts (26) together with the screws (25).
11	Remove the upper lid (3).
12	Remove the indicator rod (18) from the rod guide (17).
13	Unscrew and remove the top screws (27) from the top cover (3).
14	Separate the upper cover (3) from the eyebolt flange (14).
15	Take out the rod guide (17).
16	<p>Remove the O-rings (39, 47) from the eyebolt flange (14) and replace them, lubricating them with synthetic grease.</p> <p>! NOTICE!</p> <p>Before inserting the replacement O-rings, clean the retaining slots with a cleaning solution.</p>



PM/182 1" ÷ 2" built-in monitor;

Step	Action
17	Remove the O-ring (44) from the rod guide (17) and replace it, lubricating it with synthetic grease. NOTICE! Before inserting the replacement O-ring, clean the retaining slots with a cleaning solution.
18	Place the rod guide (17) in the eyebolt flange (14).
19	Assemble the eyebolt flange (14) with the upper lid (3).
20	Insert and fix the screws of the upper section (27) according to the following tightening torque: • 1": Tab. 9.106 • 2": Tab. 9.107 NOTICE! Tighten the screws according to the cross diagram in paragraph 9.4.2.2.
21	Insert the indicator rod (18) into the rod guide (17).
22	Unscrew and remove the balancing stem guide (11). NOTICE! Hold the diaphragm assembly in place by positioning the spanner in the holes in the upper diaphragm support (13).
23	Remove the balancing piston (15) from the balancing stem guide (11).
24	Remove and replace the O-rings (36, 43) from the balancing stem guide (11), lubricating them with synthetic grease. NOTICE! Before inserting the replacement O-rings, clean the retaining slots with a cleaning solution.
25	Place the balancing piston (15) in the piston guide (11).
26	Take out the diaphragm unit (10, 12, 13, 21, 29, 45, 50, 62)
27	Unscrew and remove the screws (29) from the lower diaphragm support (10).
28	Remove the diaphragm support (10) and the lower diaphragm protection disc (12).
29	Remove the diaphragm (50) together with the oil seal (62).
30	Remove the lower diaphragm protection disc (12) from the upper diaphragm holder (13).
31	Remove and replace the O-ring (45) from the upper diaphragm support (13), lubricating it with synthetic grease. NOTICE! Before inserting the replacement O-ring, clean the retaining slots with a cleaning solution.
32	Place the upper diaphragm protection disc (12) in the upper diaphragm holder (13). NOTICE! Check that the hole on the nozzle (21) is free from dirt or foreign bodies.
33	Position the oil seal (62).

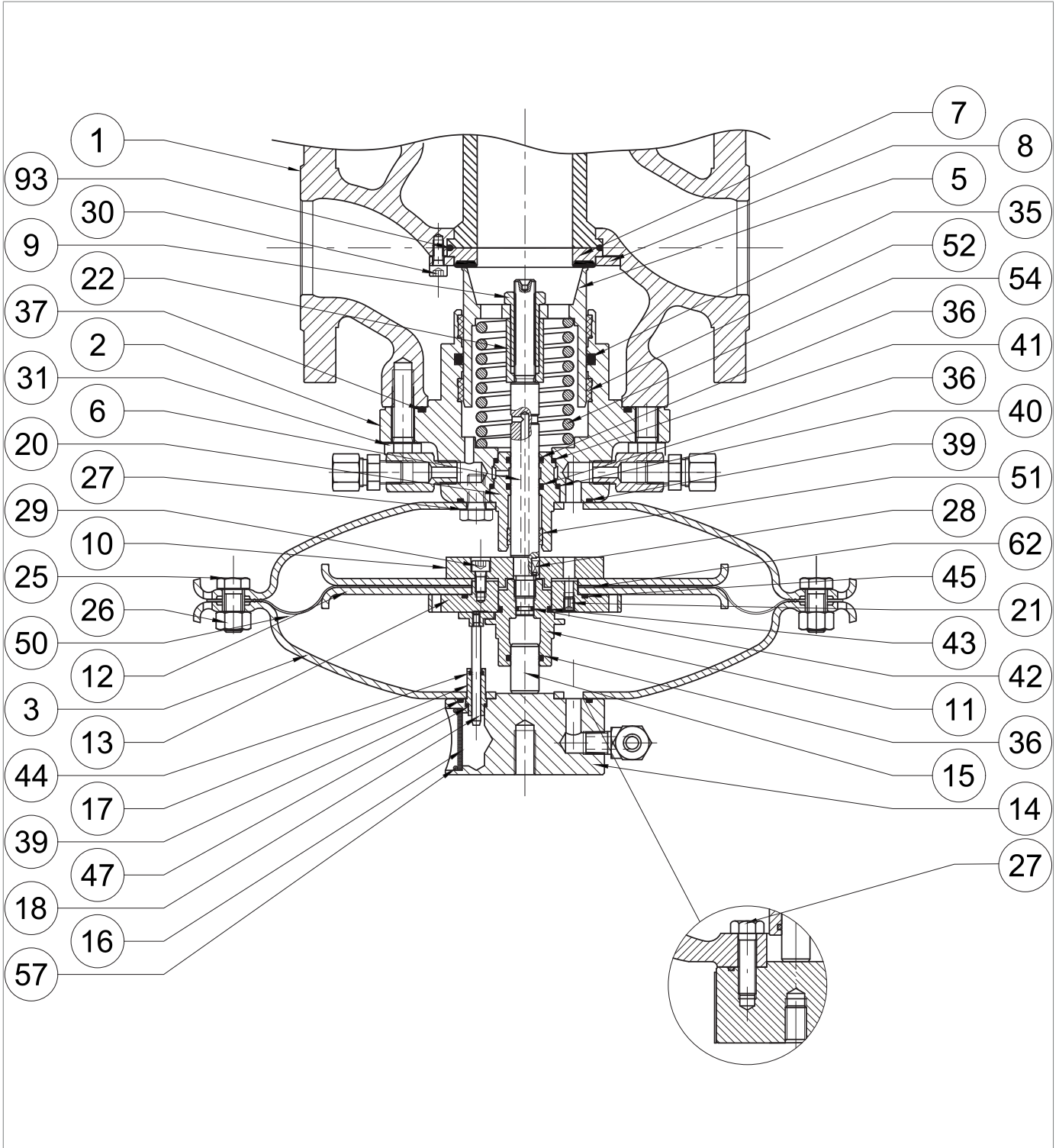

PM/182 1" ÷ 2" built-in monitor;

Step	Action
34	<p>Position the diaphragm (50).</p> <div style="border: 1px solid black; padding: 5px;"> <p>! NOTICE!</p> <p>The convex side of the diaphragm must face the drive chamber (pos. D, fig. 4.6).</p> </div>
35	<p>Apply thread locking glue to insert and fix the screws (29) according to the following tightening torque:</p> <ul style="list-style-type: none"> • 1": Tab. 9.106 • 2": Tab. 9.107 <div style="border: 1px solid black; padding: 5px;"> <p>! NOTICE!</p> <p>Tighten the screws according to the cross diagram in paragraph 9.4.2.2.</p> </div>
36	Unscrew and remove the lower part screws (27) from the lower cover (3).
37	Remove the lower cover (3).
38	<p>Remove the O-ring (93) from the plug guide (2) and replace it, taking care to lubricate it with synthetic grease.</p> <div style="border: 1px solid black; padding: 5px;"> <p>! NOTICE!</p> <p>Before inserting the replacement O-ring, clean the retaining slots with a cleaning solution.</p> </div>
39	Remove the stem guide (20), the stem (6) and the key (28).
40	<p>Remove and replace the I/DWR rings (51) from the stem guide (20).</p> <div style="border: 1px solid black; padding: 5px;"> <p>! NOTICE!</p> <p>Before inserting the replacement I/DWR ring, clean the retaining slots with a cleaning solution.</p> </div>
41	<p>Remove the O-rings (36) from the stem guide (20) and replace them, lubricating them with synthetic grease.</p> <div style="border: 1px solid black; padding: 5px;"> <p>! NOTICE!</p> <p>Before inserting the replacement O-ring, clean the retaining slots with a cleaning solution.</p> </div>
42	<p>Remove the O-rings (40, 41) from the stem guide (20) and replace them, lubricating them with synthetic grease.</p> <div style="border: 1px solid black; padding: 5px;"> <p>! NOTICE!</p> <p>Before inserting the replacement O-rings, clean the retaining slots with a cleaning solution.</p> </div>
43	<p>Remove the O-ring (42) from the stem (6) and replace it, lubricating it with synthetic grease.</p> <div style="border: 1px solid black; padding: 5px;"> <p>! NOTICE!</p> <p>Before inserting the replacement O-ring, clean the retaining slots with a cleaning solution.</p> </div>
44	<p>Remove the stem guide (20), the stem (6) and the key (28).</p> <div style="border: 1px solid black; padding: 5px;"> <p>! NOTICE!</p> <p>Lubricate the stem surface with silicone grease; make sure that the key (28) is in the correct position in the stem (6).</p> </div>

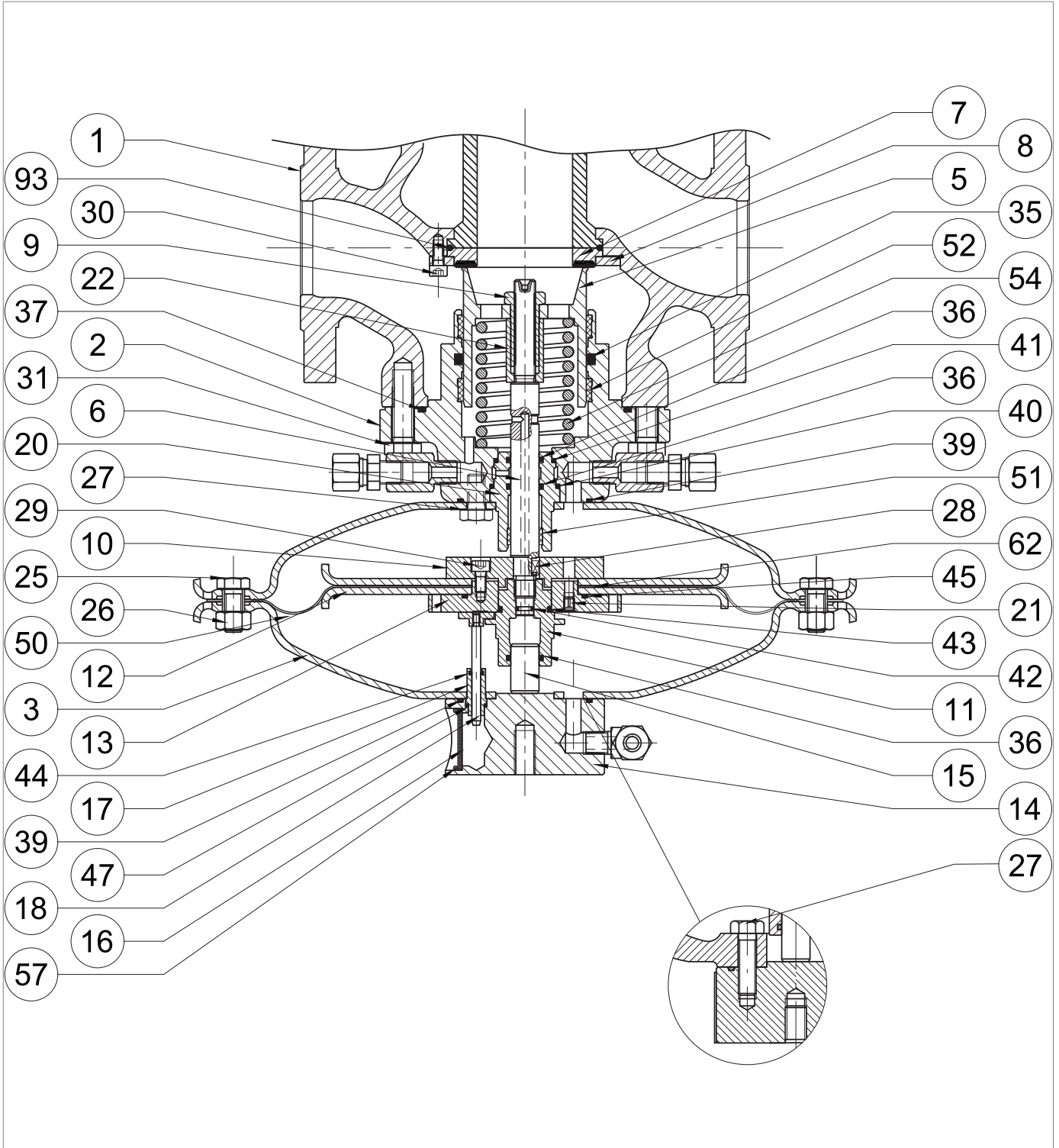



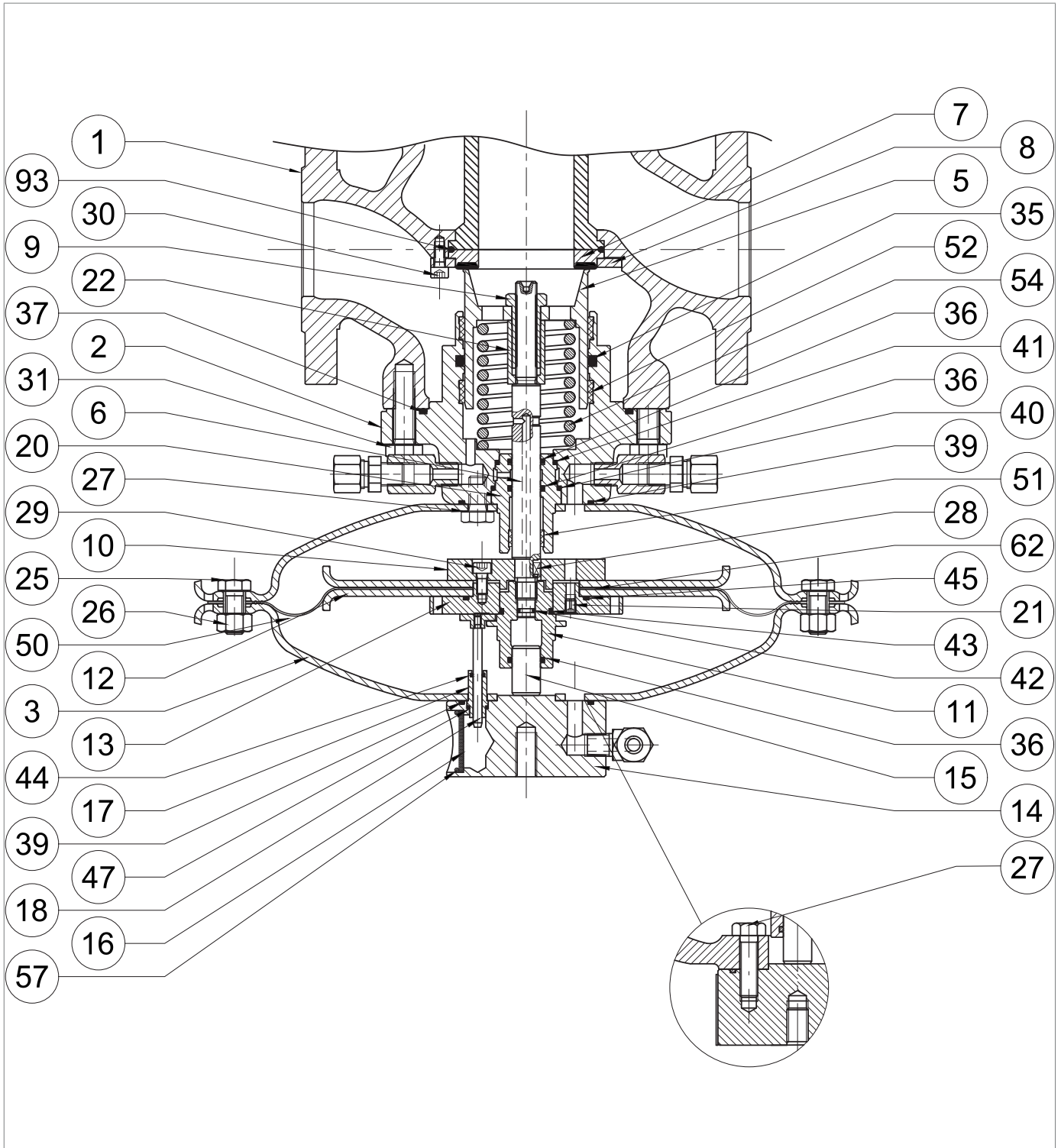

PM/182 1" ÷ 2" built-in monitor;

Step	Action
45	Place the lower cover (3) on the plug guide (2). NOTICE! The hole for the passage of the loading pressure must match the similar one on the plug guide.
46	Insert and fasten the screws of the lower part (27) in the lower cover (3) according to the tightening torque: • 1": Tab. 9.106 • 2": Tab. 9.107 NOTICE! Tighten the screws according to the cross diagram in paragraph 9.4.2.2.
47	Put the diaphragm unit in place (10, 12, 13, 21, 29, 45, 50, 62).
48	Make sure that the key (28) is in the correct position in the stem (6).
49	Insert and secure the balancing stem guide (11) according to the tightening torque: • 1": Tab. 9.106 • 2": Tab. 9.107 NOTICE! During this phase: • hold the diaphragm assembly in place by positioning the spanner in the holes in the upper diaphragm support (13); • The holes in the diaphragm must match the holes in the lower cover (3).
50	Position the upper cover (3), taking care to position the indicator stem (18) in the space between the upper diaphragm support (13) and the balance stem guide (11). NOTICE! • The indicator rod (18) must not obstruct the pouring hole (21) on the upper diaphragm support (13); • The flange travel indicator must be visible and perpendicular to the gas flow
51	Insert and fasten the screws (25) with the nuts (26) according to the tightening torque: • 1": Tab. 9.106 • 2": Tab. 9.107 NOTICE! Tighten the screws according to the cross diagram in paragraph 9.4.2.2.
52	Put the spacer (22) and the spring (54) in place. NOTICE! Fit the spacer (34) so that the stop with the narrower hole rests on the surface of the stem (6).
53	Insert the plug (5).
54	Insert the locking nut (9) according to the tightening torque: • 1": Tab. 9.106 • 2": Tab. 9.107 NOTICE! Before fixing the lock nut (9), check that the spring (80) is well seated in the appropriate centring stop on the plug guide (70).



PM/182 1" ÷ 2" built-in monitor;

Step	Action
55	Unscrew and remove screws (30), shaft collar (8), reinforced gasket (7) and O-ring (93). <div style="border: 1px solid black; padding: 5px;">  NOTICE! Take care that the upper seal does not fall off. </div>
56	Remove the O-ring (39) from the reinforced gasket (7) and replace it, lubricating it with synthetic grease. <div style="border: 1px solid black; padding: 5px;">  NOTICE! Before inserting the replacement O-ring, clean the retaining slots with a cleaning solution. </div>
57	Position the reinforced gasket (7) and the shaft collar (8).
58	Insert and fix the screws (30) according to the following tightening torque: <ul style="list-style-type: none"> • 1": Tab. 9.106 • 2": Tab. 9.107 <div style="border: 1px solid black; padding: 5px;">  NOTICE! Tighten the screws according to the cross diagram in paragraph 9.4.2.2. </div>
59	Position the control head inside the regulator body (1) with the indicator slide (16) visible and on axis with the gas flow direction. <div style="border: 1px solid black; padding: 5px;">  NOTICE! Take care not to damage the plug profile (5). </div>
60	Insert and fix the screws (31) according to the following tightening torque: <ul style="list-style-type: none"> • 1": Tab. 9.106 • 2": Tab. 9.107 <div style="border: 1px solid black; padding: 5px;">  NOTICE! Tighten the screws according to the cross diagram in paragraph 9.4.2.2. </div>
61	Connect the pneumatic connections between the regulator and the respective control unit, including downstream pressure ports.

Tab. 9.151.

 **WARNING!**

Ensure that all parts have been fitted correctly.

9.4.5.2 - BUILT-IN MONITOR PM/182 2" ½ ÷ 4"

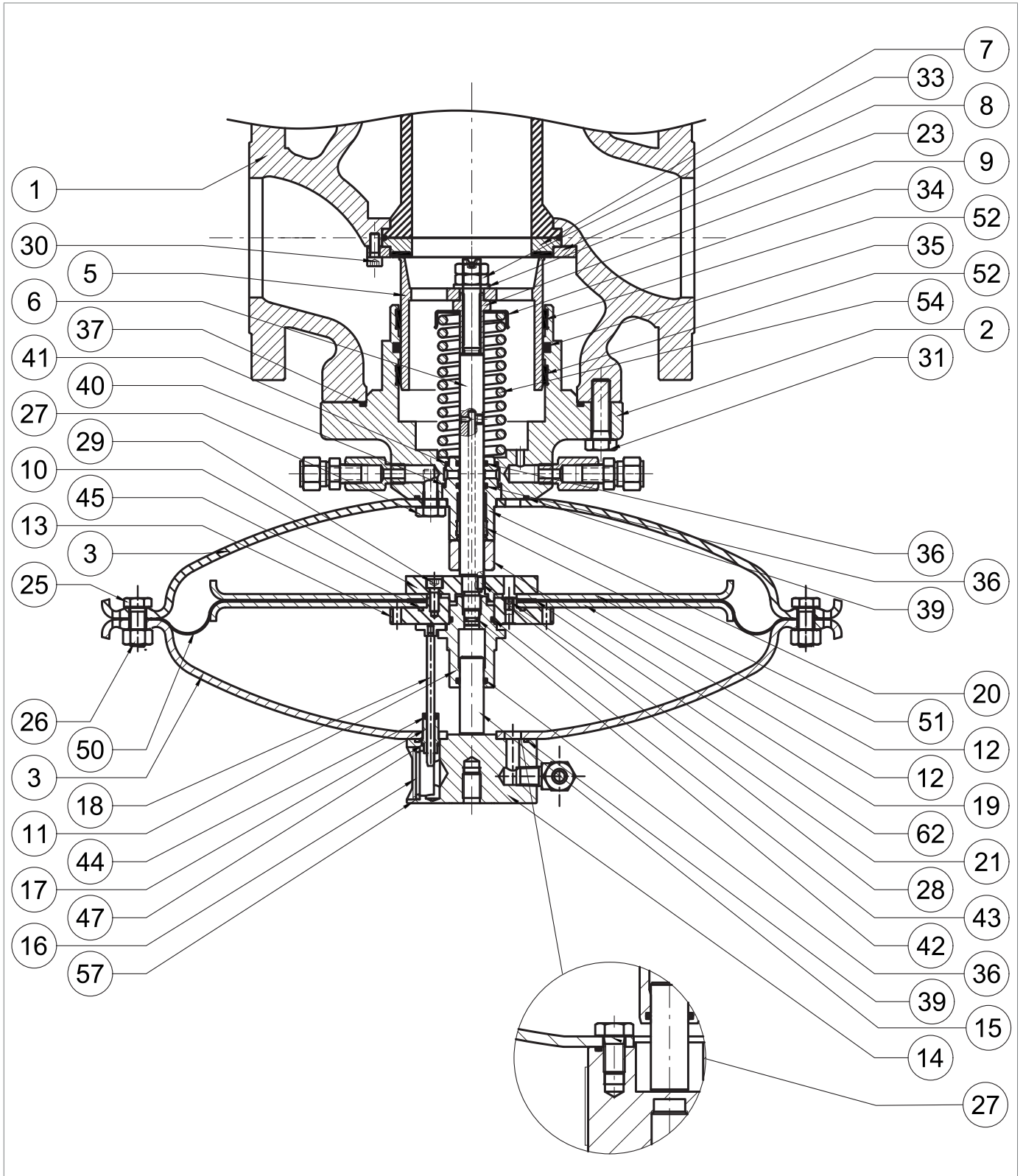
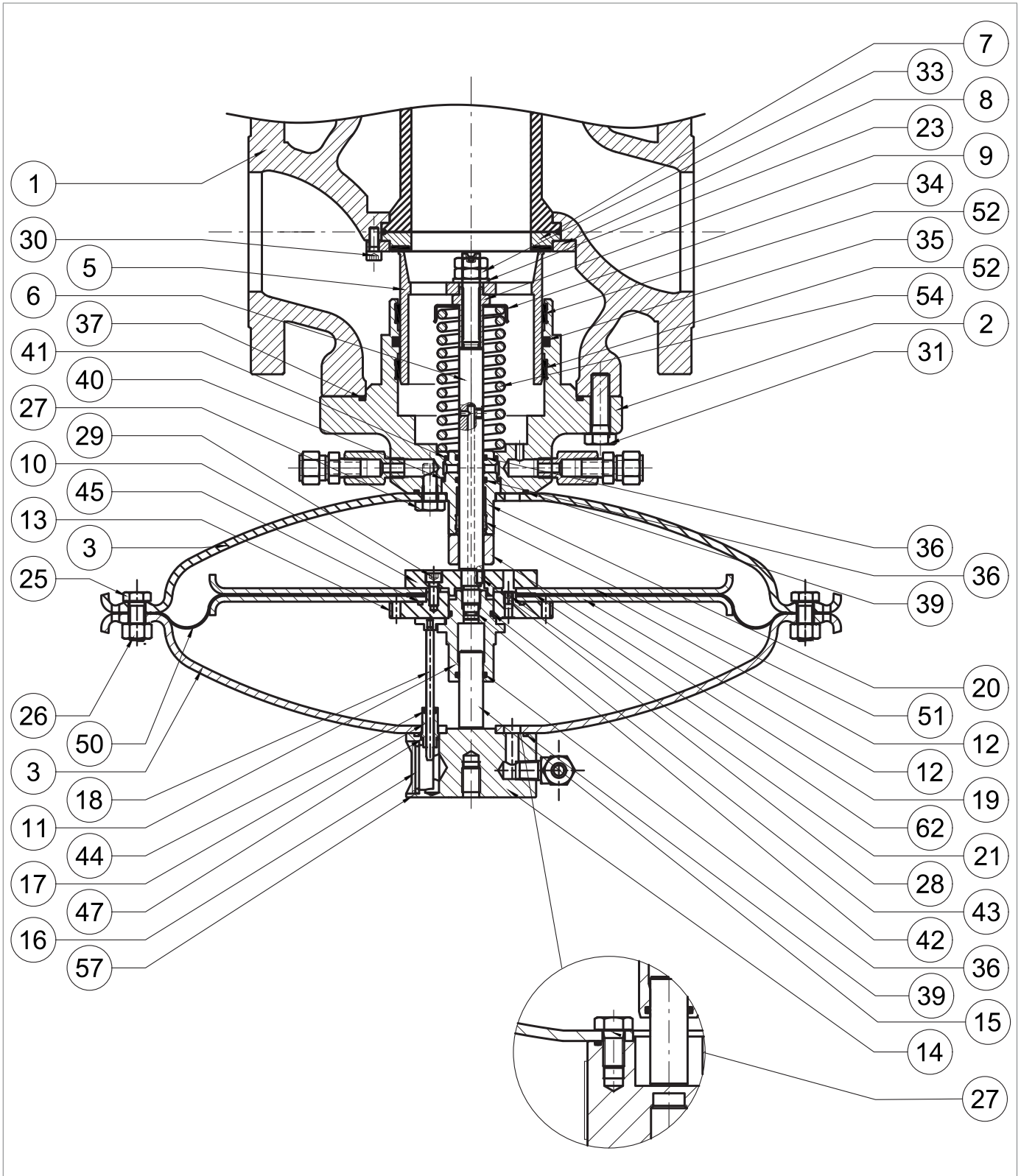

Fig. 9.75. Built-in monitor PM/182 2" ½ ÷ 4"

Step	Action
1	<p>Unscrew and remove the screws (31) securing the control head to the regulator body (1).</p> <p>! NOTICE!</p> <p>Support the head assembly during this step to avoid falls.</p>
2	<p>Remove the control head and place it on its side in a plane with an impact-resistant surface.</p> <p>! NOTICE!</p> <p>Take care not to damage the plug profile (5).</p>
3	<p>Remove the O-ring (37) from the plug guide (2) and replace it, lubricating it with synthetic grease.</p> <p>! NOTICE!</p> <p>Before inserting the replacement O-ring, clean the retaining slots with a cleaning solution.</p>
4	<p>Unscrew and remove the nuts (33) together with the washer (23).</p> <p>! NOTICE!</p> <p>During this phase, the spring (54) decompresses and pushes the plug (5) outwards.</p>
5	<p>Remove the plug (5) and place it on an anti-shock surface.</p>
6	<p>Unscrew the locking nut (9) to release the spring.</p> <p>! NOTICE!</p> <p>Take care not to damage the plug profile (5).</p>
7	<p>Remove the spring support (34) and the spring (54).</p>
8	<p>Remove and replace the I/DWR rings (52) from the plug guide (2).</p> <p>! NOTICE!</p> <p>Before inserting the replacement I/DWR rings, clean the retaining slots with a cleaning solution.</p>
9	<p>Remove the O-ring (35) from the plug guide (2) and replace it, lubricating it with synthetic grease.</p> <p>! NOTICE!</p> <p>Before inserting the replacement O-ring, clean the retaining slots with a cleaning solution.</p>
10	<p>Clean the plug (5) and the plug guide (2) lubricating with silicone grease.</p>
11	<p>Unscrew and remove the nuts (26, 97) together with the screws (25, 98).</p>
12	<p>Remove the upper lid (3).</p>
13	<p>Remove the indicator rod (18) from the rod guide (17).</p>
14	<p>Unscrew and remove the top screws (27) from the top cover (3).</p>
15	<p>Separate the upper cover (3) from the eyebolt flange (14).</p>
16	<p>Take out the rod guide (17).</p>
17	<p>Remove the O-rings (39, 47) from the eyebolt flange (14) and replace them, lubricating them with synthetic grease.</p> <p>! NOTICE!</p> <p>Before inserting the replacement O-ring, clean the retaining slots with a cleaning solution.</p>







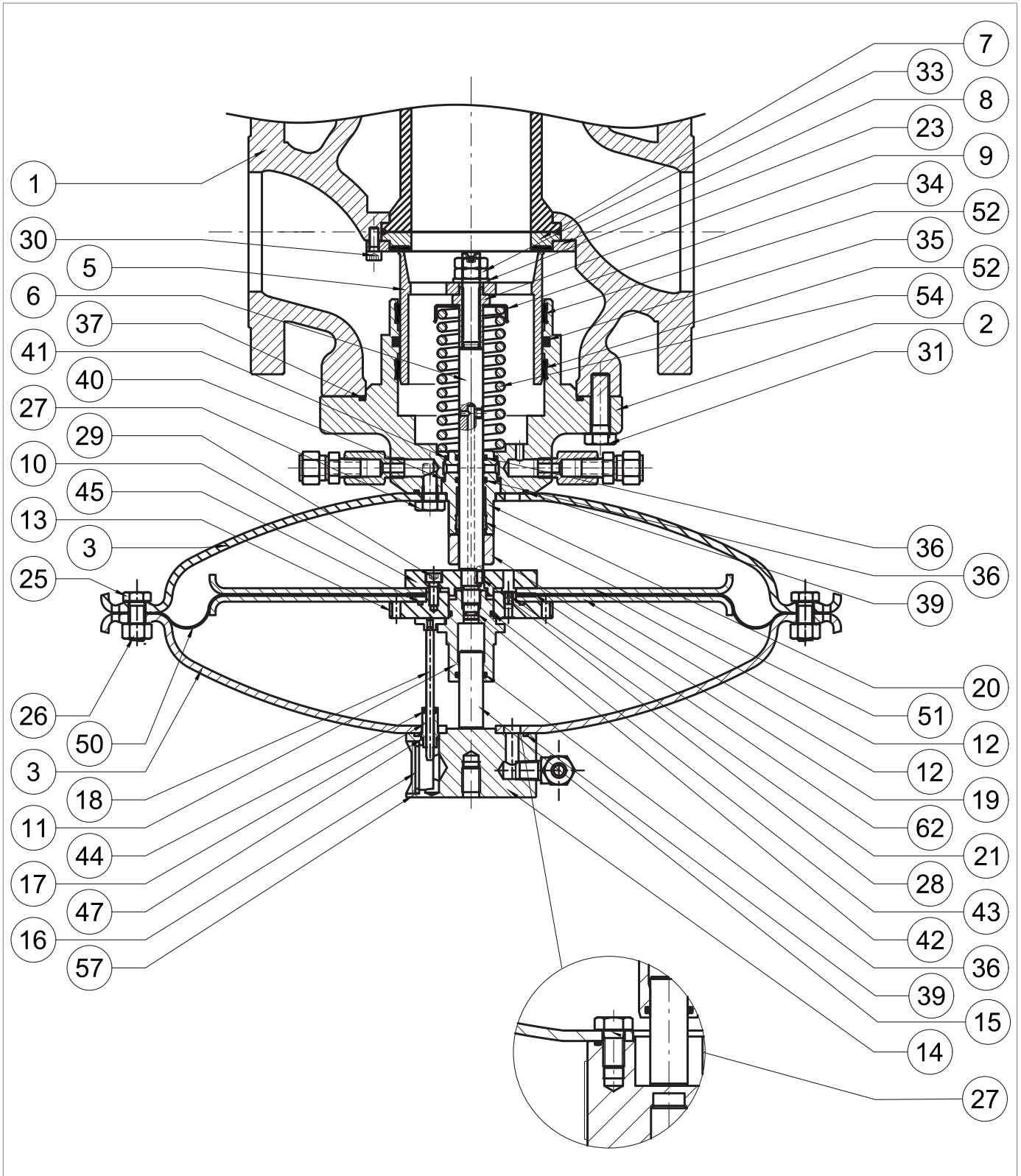



Built-in monitor PM/182 2" 1/2 ÷ 4"

Step	Action
18	Remove the O-ring (44) from the rod guide (17) and replace it, lubricating it with synthetic grease. NOTICE! Before inserting the replacement O-ring, clean the retaining slots with a cleaning solution.
19	Place the rod guide (17) in the eyebolt flange (14).
20	Assemble the eyebolt flange (14) with the upper lid (3).
21	Insert and fasten the screws of the upper part (27) in the upper cover (3) according to the tightening torque: <ul style="list-style-type: none"> • 2" ½: Tab. 9.108 • 3": Tab. 9.109 • 4": Tab. 9.110 NOTICE! Tighten the screws according to the cross diagram in paragraph 9.4.2.2.
22	Insert the indicator rod (18) into the rod guide (17).
23	Unscrew and remove the balancing stem guide (11). NOTICE! Hold the diaphragm assembly in place by positioning the spanner in the holes in the upper diaphragm support (13).
24	Remove the balancing piston (15) from the balancing stem guide (11).
25	Remove and replace the O-rings (36, 43) from the balancing stem guide (11), lubricating them with synthetic grease. NOTICE! Before inserting the replacement O-rings, clean the retaining slots with a cleaning solution.
26	Position the balancing piston (15) in the balancing stem guide (11).
27	Take out the diaphragm unit (10, 12, 13, 21, 29, 45, 50, 62)
28	Unscrew and remove the screws (29) from the lower diaphragm support (10).
29	Remove the diaphragm support (10) and the lower diaphragm protection disc (12).
30	Remove and replace the diaphragm (50) together with the oil seal (62).
31	Remove the lower diaphragm protection disc (12) from the upper diaphragm holder (13).
32	Remove and replace the O-ring (45) from the upper diaphragm support (13), lubricating it with synthetic grease. NOTICE! Before inserting the replacement O-ring, clean the retaining slots with a cleaning solution.
33	Place the upper diaphragm protection disc (12) in the upper diaphragm holder (13). NOTICE! Check that the hole on the nozzle (21) is free from dirt or foreign bodies.



Built-in monitor PM/182 2" 1/2 ÷ 4"

Step	Action
34	Position the diaphragm (50). <div style="border: 1px solid black; padding: 5px;">  NOTICE! The convex side of the diaphragm must face the drive chamber (pos. D, fig. 4.6). </div>
35	Position the oil seal (62).
36	Put the diaphragm protection disc (12) and the lower diaphragm support (10) in place. <div style="border: 1px solid black; padding: 5px;">  NOTICE! Check that the nozzle hole on the upper diaphragm support (13) is aligned with the hole on the lower diaphragm support (10). </div>
37	Apply thread locking glue to insert and fix the screws (29) according to the following tightening torque: <ul style="list-style-type: none"> • 2" ½: Tab. 9.108 • 3": Tab. 9.109 • 4": Tab. 9.110 <div style="border: 1px solid black; padding: 5px;">  NOTICE! Tighten the screws according to the cross diagram in paragraph 9.4.2.2. </div>
38	Unscrew and remove the screws of the lower part (27) in the lower cover (3).
39	Remove the lower cover (3).
40	Remove the O-ring (39) from the plug guide (2) and replace it, lubricating it with synthetic grease. <div style="border: 1px solid black; padding: 5px;">  NOTICE! Before inserting the replacement O-ring, clean the retaining slots with a cleaning solution. </div>
41	Remove the stem guide (20), the stem (6) and the key (28).
42	Remove and replace the I/DWR rings (51) from the stem guide (20). <div style="border: 1px solid black; padding: 5px;">  NOTICE! Before inserting the replacement O-ring, clean the retaining slots with a cleaning solution. </div>
43	Remove the O-rings (36) from the stem guide (20) and replace them, lubricating them with synthetic grease. <div style="border: 1px solid black; padding: 5px;">  NOTICE! Before inserting the replacement O-ring, clean the retaining slots with a cleaning solution. </div>
44	Remove the O-rings (40, 41) from the stem guide (20) and replace them, lubricating them with synthetic grease. <div style="border: 1px solid black; padding: 5px;">  NOTICE! Before inserting the replacement O-rings, clean the retaining slots with a cleaning solution. </div>
45	Remove the O-ring (42) from the stem (6) and replace it, lubricating it with synthetic grease. <div style="border: 1px solid black; padding: 5px;">  NOTICE! Before inserting the replacement O-ring, clean the retaining slots with a cleaning solution. </div>

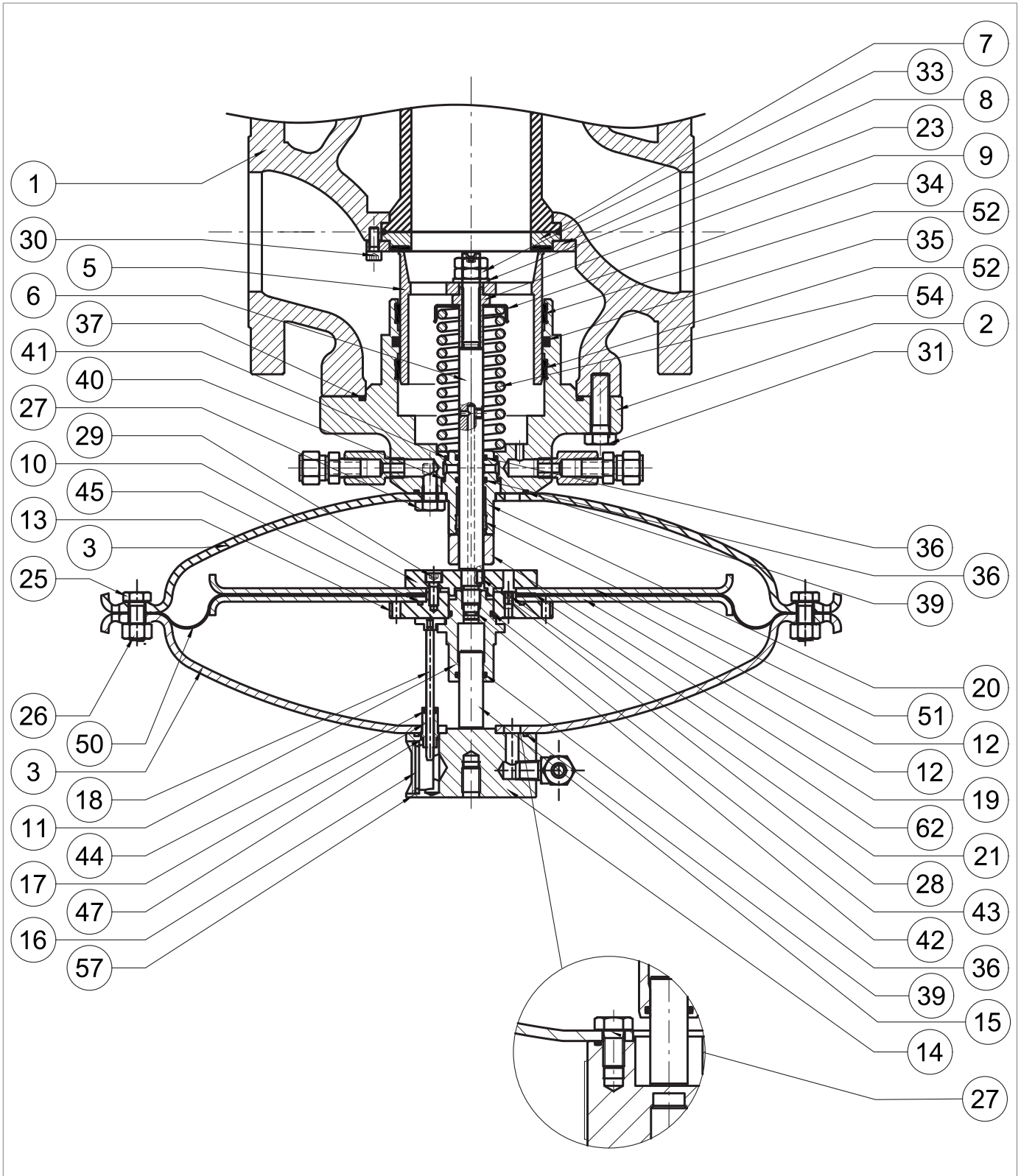

Built-in monitor PM/182 2" 1/2 ÷ 4"

Step	Action
46	<p>Remove the stem guide (20), the stem (6) and the key (28).</p> <div style="border: 1px solid black; padding: 5px;"> <p>! NOTICE!</p> <ul style="list-style-type: none"> • Lubricate the stem surface with silicone grease • The key (28) must be in the correct position in the stem (6). </div>
47	<p>Put the lower cover (3) in place and fix it on the plug guide (2).</p> <div style="border: 1px solid black; padding: 5px;"> <p>! NOTICE!</p> <p>Match the hole for the passage of the loading pressure to the similar one on the plug guide.</p> </div>
48	<p>Insert and fasten the screws of the lower part (27) in the lower cover (3) according to the tightening torque:</p> <ul style="list-style-type: none"> • 2" ½: Tab. 9.108 • 3": Tab. 9.109 • 4": Tab. 9.110 <div style="border: 1px solid black; padding: 5px;"> <p>! NOTICE!</p> <p>Tighten the screws according to the cross diagram in paragraph 9.4.2.2.</p> </div>
49	Put the diaphragm unit in place (10, 12, 13, 21, 29, 45, 50, 62).
50	Make sure that the key (28) is in the correct position in the stem (6).
51	<p>Insert and secure the balancing stem guide (11) according to the tightening torque:</p> <ul style="list-style-type: none"> • 2" ½: Tab. 9.108 • 3": Tab. 9.109 • 4": Tab. 9.110 <div style="border: 1px solid black; padding: 5px;"> <p>! NOTICE!</p> <p>Hold the diaphragm assembly in place by positioning the spanner in the holes in the upper diaphragm support (13).</p> </div>
52	<p>Position the upper cover (3), taking care to position the indicator stem (18) in the space between the upper diaphragm support (13) and the balance stem guide (11).</p> <div style="border: 1px solid black; padding: 5px;"> <p>! NOTICE!</p> <ul style="list-style-type: none"> • The indicator rod (18) must not obstruct the pouring hole (21) on the upper diaphragm support (13); • The flange travel indicator must be perpendicular to the gas flow and visible. </div>
53	Place the pilot support screw (98).
54	<p>Insert and fasten the screws (25) with the nuts (26) according to the tightening torque:</p> <ul style="list-style-type: none"> • 2" ½: Tab. 9.108 • 3": Tab. 9.109 • 4": Tab. 9.110
55	<p>Position the spring holder (34) and spring (54).</p> <div style="border: 1px solid black; padding: 5px;"> <p>! NOTICE!</p> <p>Check that the spring (54) is properly seated in the centring stop on the plug guide (2).</p> </div>

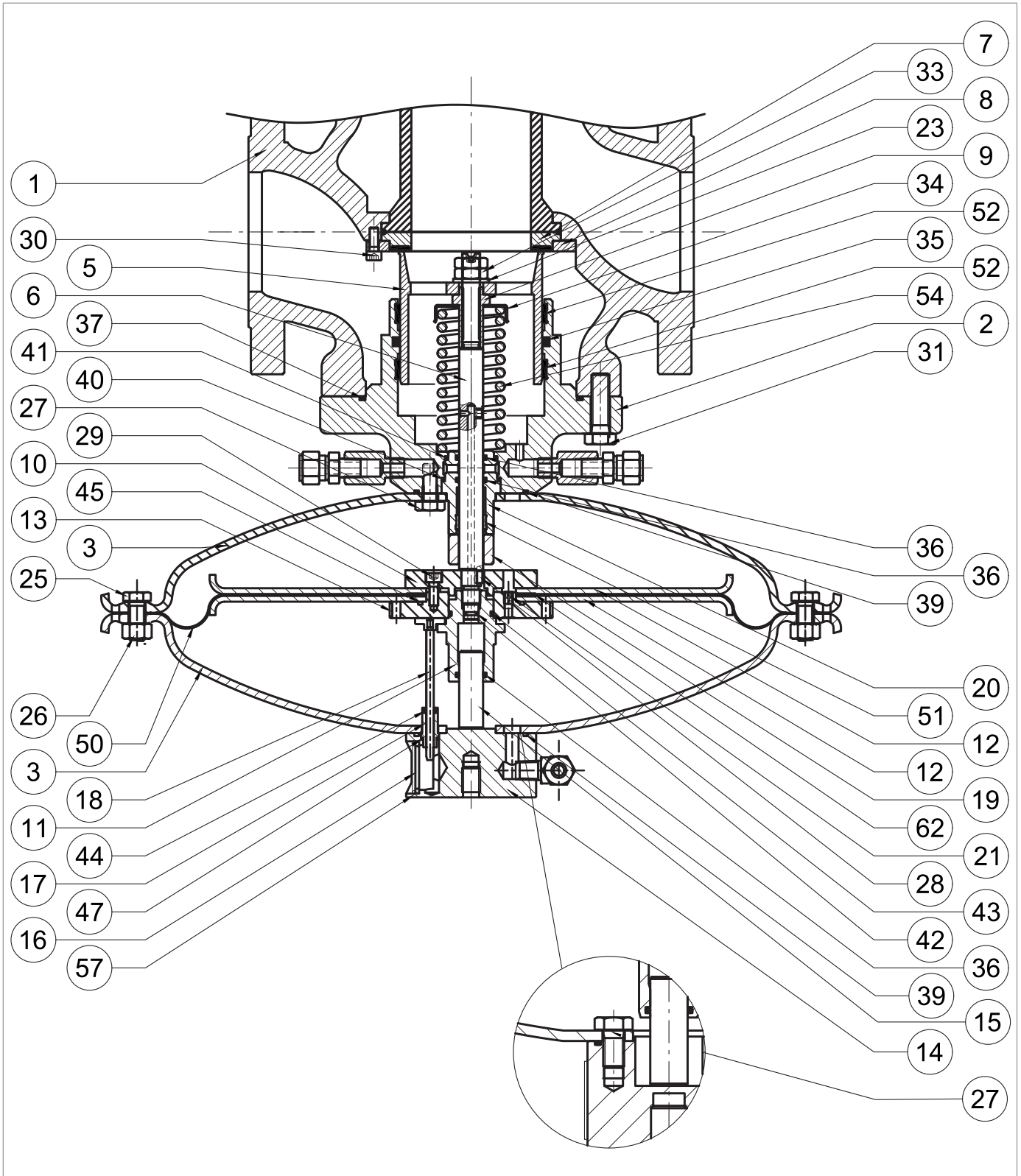

Built-in monitor PM/182 2" 1/2 ÷ 4"

Step	Action
56	<p>Insert the locking nut (9) according to the tightening torque:</p> <ul style="list-style-type: none"> • 2" ½: Tab. 9.108 • 3": Tab. 9.109 • 4": Tab. 9.110 <div style="border: 1px solid black; padding: 5px;"> <p>! NOTICE!</p> <p>Tighten the screws according to the cross diagram in paragraph 9.4.2.2.</p> </div>
57	Insert the plug (5).
58	<p>Unscrew and remove screws (30), shaft collar (8), reinforced gasket (7) and O-ring (93).</p> <div style="border: 1px solid black; padding: 5px;"> <p>! NOTICE!</p> <p>Take care that the upper seal does not fall off.</p> </div>
59	<p>Remove the O-ring (93) from the reinforced gasket (7) and replace it, lubricating it with synthetic grease.</p> <div style="border: 1px solid black; padding: 5px;"> <p>! NOTICE!</p> <p>Before inserting the replacement O-ring, clean the retaining slots with a cleaning solution.</p> </div>
60	Position the reinforced gasket (7) and the shaft collar (8).
61	<p>Insert and fix the screws (30) according to the following tightening torque:</p> <ul style="list-style-type: none"> • 2" ½: Tab. 9.108 • 3": Tab. 9.109 • 4": Tab. 9.110 <div style="border: 1px solid black; padding: 5px;"> <p>! NOTICE!</p> <p>Tighten the screws according to the cross diagram in paragraph 9.4.2.2.</p> </div>
62	<p>Position the control head inside the regulator body (1) with the indicator slide (16) visible and on axis with the gas flow direction.</p> <div style="border: 1px solid black; padding: 5px;"> <p>! NOTICE!</p> <p>Take care not to damage the plug profile (5).</p> </div>
63	<p>Insert and fix the screws (31) according to the following tightening torque:</p> <ul style="list-style-type: none"> • 2" ½: Tab. 9.108 • 3": Tab. 9.109 • 4": Tab. 9.110 <div style="border: 1px solid black; padding: 5px;"> <p>! NOTICE!</p> <p>Tighten the screws according to the cross diagram in paragraph 9.4.2.2.</p> </div>
64	Connect the pneumatic connections between the regulator and the respective control unit, including downstream pressure ports.

Tab. 9.152.

! WARNING!

Ensure that all parts have been fitted correctly.

9.4.5.3 - BUILT-IN MONITOR PM/182 6" ÷ 8"

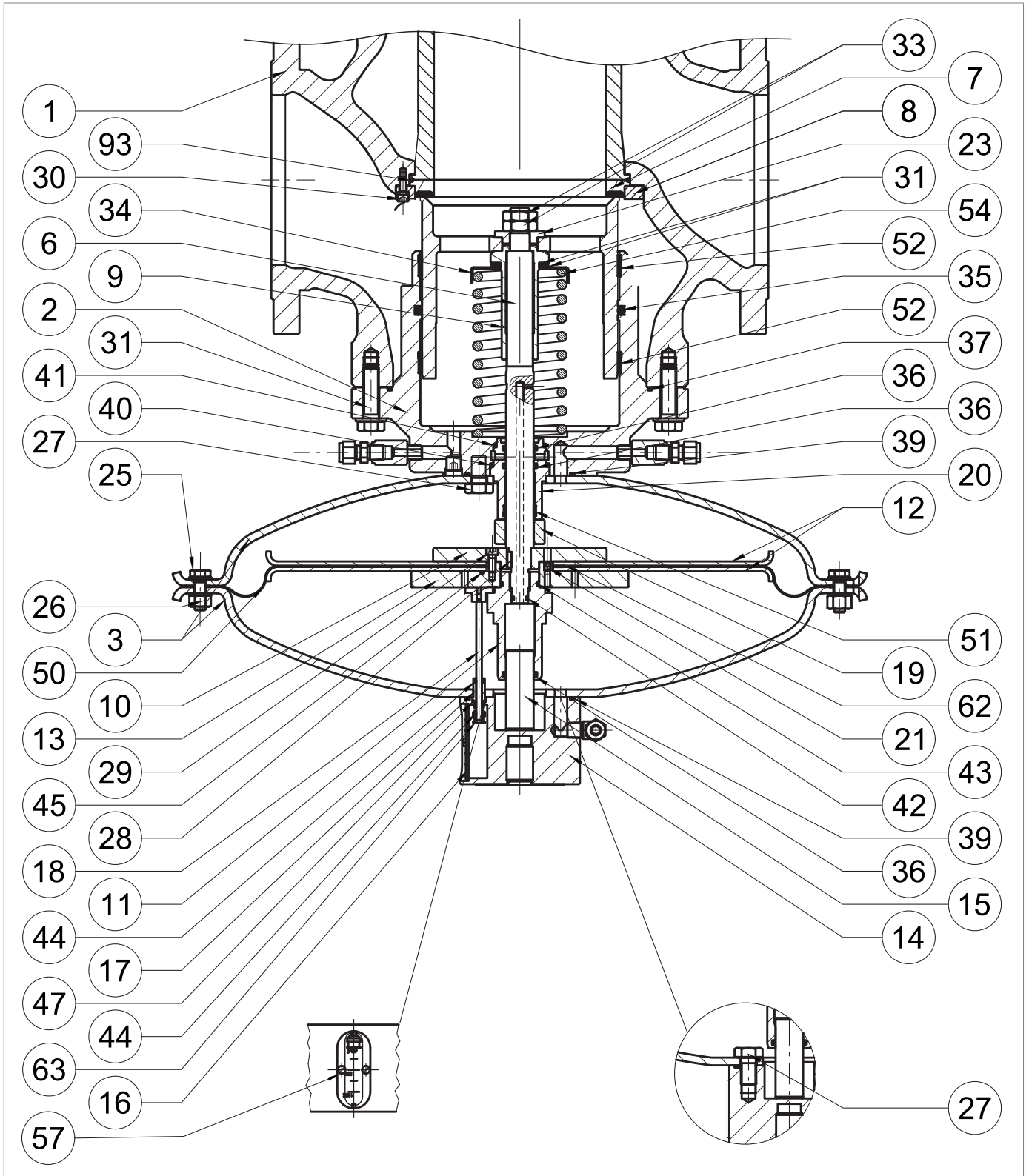
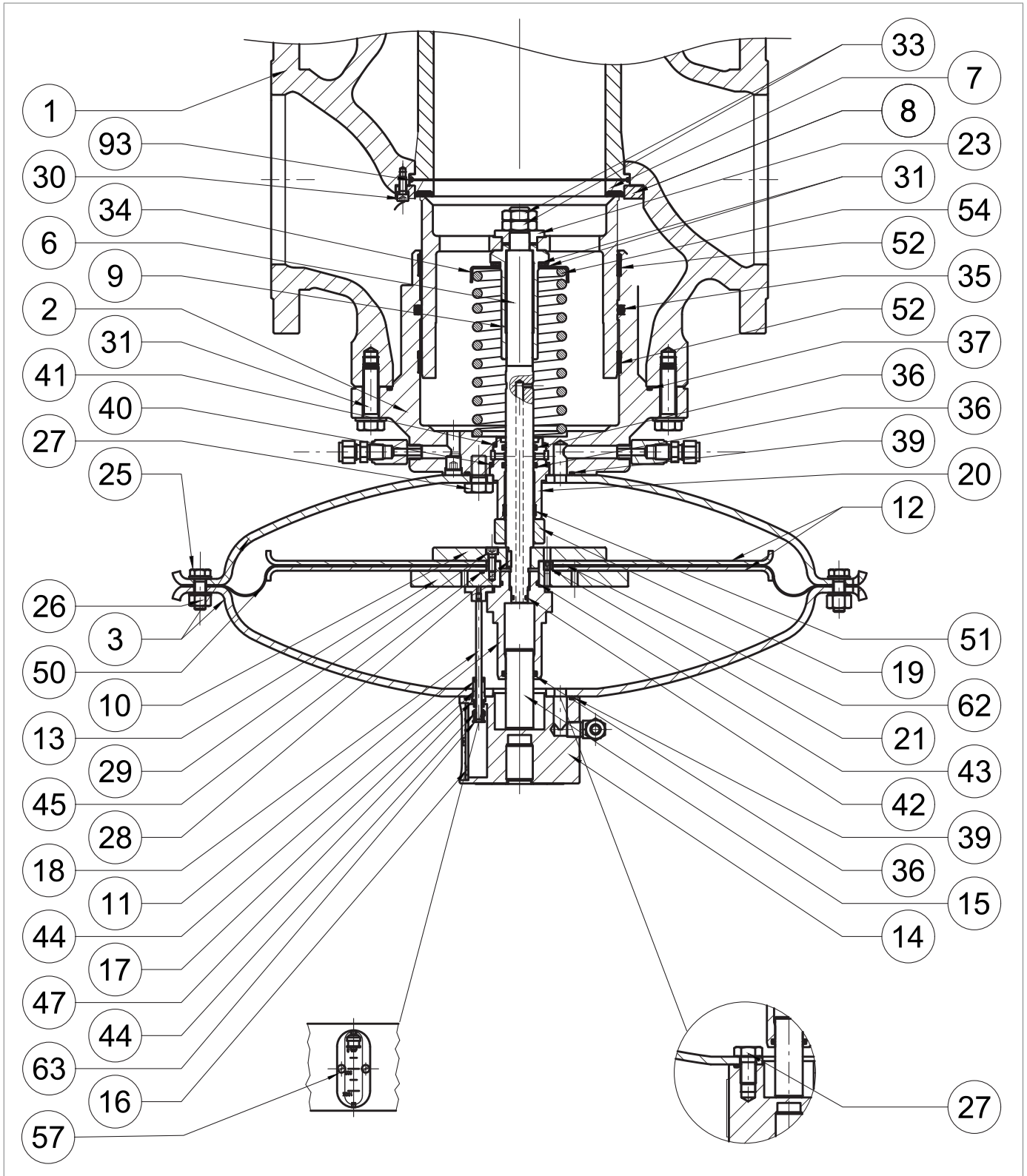

Fig. 9.76. BUILT-IN MONITOR PM/182 6" ÷ 8"

Step	Action
1	<p>Unscrew and remove the screws (31) securing the control head to the regulator body (1).</p> <div style="border: 1px solid black; padding: 5px;"> <p>! NOTICE!</p> <p>Support the head assembly during this step to avoid falls.</p> </div>
2	<p>Remove the control head and place it on its side in a plane with an impact-resistant surface.</p> <div style="border: 1px solid black; padding: 5px;"> <p>! NOTICE!</p> <p>Take care not to damage the plug profile (5).</p> </div>
3	<p>Remove the O-ring (37) from the plug guide (2) and replace it, lubricating it with synthetic grease.</p> <div style="border: 1px solid black; padding: 5px;"> <p>! NOTICE!</p> <p>Before inserting the replacement O-ring, clean the retaining slots with a cleaning solution.</p> </div>
4	Unscrew and remove the nuts (33) together with the washer (23).
5	Remove the plug (5) and place it on an anti-shock surface.
6	<p>Unscrew the locking nut (9) to release the spring tension.</p> <div style="border: 1px solid black; padding: 5px;"> <p>! NOTICE!</p> <p>Take care not to damage the plug profile (5).</p> </div>
7	Remove the spring support (34) and the spring (54).
8	<p>Remove and replace the I/DWR rings (52) from the plug guide (2).</p> <div style="border: 1px solid black; padding: 5px;"> <p>! NOTICE!</p> <p>Before inserting the replacement I/DWR rings, clean the retaining slots with a cleaning solution.</p> </div>
9	<p>Remove the O-ring (35) from the plug guide (2) and replace it, lubricating it with synthetic grease.</p> <div style="border: 1px solid black; padding: 5px;"> <p>! NOTICE!</p> <p>Before inserting the replacement O-ring, clean the retaining slots with a cleaning solution.</p> </div>
10	Clean the plug (5) and the plug guide (2) lubricating with silicone grease.
11	Unscrew and remove the nuts (26) together with the screws (25, 98).
12	Remove the upper lid (3).
13	Remove the indicator rod (18) from the rod guide (17).
14	Unscrew and remove the top screws (27) from the top cover (3).
15	Separate the upper cover (3) from the eyebolt flange (14).
16	Take out the rod guide (17).
17	<p>Remove the O-rings (39, 47) from the eyebolt flange (14) and replace them, lubricating them with synthetic grease.</p> <div style="border: 1px solid black; padding: 5px;"> <p>! NOTICE!</p> <p>Before inserting the replacement O-ring, clean the retaining slots with a cleaning solution.</p> </div>



BUILT-IN MONITOR PM/182 6" ÷ 8"

Step	Action
18	Remove the O-ring (44) from the rod guide (17) and replace it, lubricating it with synthetic grease. NOTICE! Before inserting the replacement O-ring, clean the retaining slots with a cleaning solution.
19	Unscrew and remove the position screws (57) together with the indicator slide (16) and pawl (163).
20	Remove and replace the O-ring (44) from the pawl (163), lubricating it with synthetic grease. NOTICE! Before inserting the replacement O-ring, clean the retaining slots with a cleaning solution.
21	Place the rod guide (17) in the eyebolt flange (14).
22	Assemble the eyebolt flange (14) with the upper lid (3).
23	Insert and fasten the screws of the upper part (27) in the upper cover (3) according to the tightening torque: <ul style="list-style-type: none"> • 6": Tab. 9.111 • 8": Tab. 9.112 NOTICE! Tighten the screws according to the cross diagram in paragraph 9.4.2.2.
24	Insert the indicator rod (18) into the rod guide (17).
25	Unscrew and remove the balancing stem guide (11). NOTICE! Hold the diaphragm assembly in place by positioning the spanner in the holes in the upper diaphragm support (13).
26	Remove the balancing piston (15) from the balancing stem guide (11).
27	Remove the O-rings (36, 43) from the eyebolt flange (11) and replace them, lubricating them with synthetic grease. NOTICE! Before inserting the replacement O-rings, clean the retaining slots with a cleaning solution.
28	Place the balancing piston (15) in the piston guide (11).
29	Take out the diaphragm unit (10, 12, 13, 21, 29, 45, 50, 62)
30	Unscrew and remove the screws (29) from the lower diaphragm support (10).
31	Remove the diaphragm support (10) and the lower diaphragm protection disc (12).
32	Remove the diaphragm (50) together with the oil seal (62).
33	Remove the lower diaphragm protection disc (12) from the upper diaphragm holder (13).
34	Remove and replace the O-ring (45) from the upper diaphragm support (13), lubricating it with synthetic grease. NOTICE! Before inserting the replacement O-ring, clean the retaining slots with a cleaning solution.
35	Place the upper diaphragm protection disc (12) in the upper diaphragm holder (13). NOTICE! Check that the hole on the nozzle (21) is free from dirt or foreign bodies.

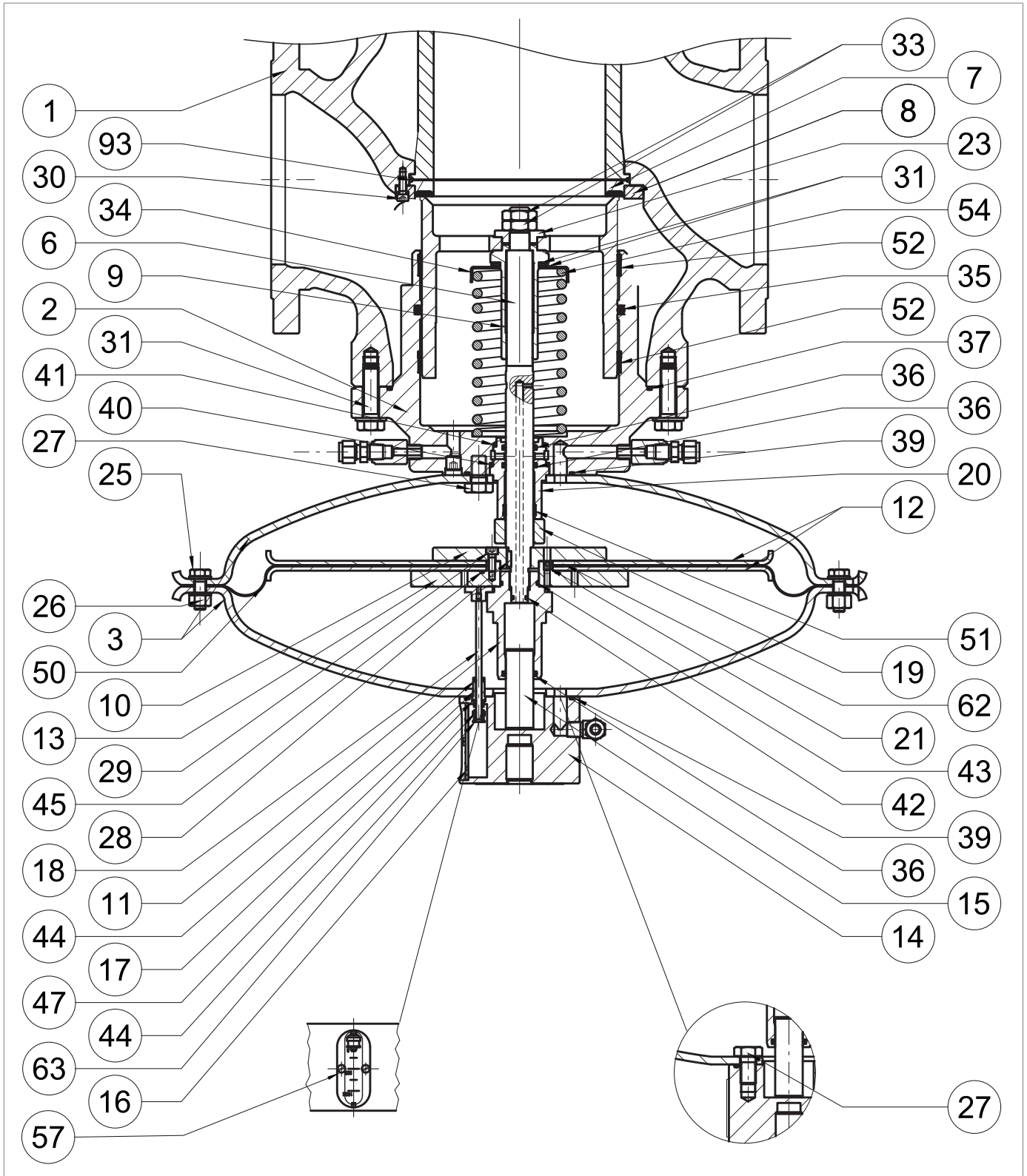

BUILT-IN MONITOR PM/182 6" ÷ 8"

Step	Action
36	Position the oil seal (62).
37	Position the diaphragm (50). ! NOTICE! The convex side of the diaphragm must face the drive chamber (pos. D, fig. 4.6).
38	Put the diaphragm protection disc (12) and the lower diaphragm support (10) in place. ! NOTICE! Check that the nozzle hole on the upper diaphragm support (13) is aligned with the hole on the lower diaphragm support (10).
39	Apply thread locking glue to insert and fix the screws (29) according to the following tightening torque: <ul style="list-style-type: none"> • 6": Tab. 9.111 • 8": Tab. 9.112 ! NOTICE! Tighten the screws according to the cross diagram in paragraph 9.4.2.2.
40	Unscrew and remove the screws of the lower part (27) in the lower cover (3).
41	Remove the lower cover (3).
42	Remove the O-ring (39) from the plug guide (2) and replace it, lubricating it with synthetic grease. ! NOTICE! Before inserting the replacement O-ring, clean the retaining slots with a cleaning solution.
43	Remove the stem guide (20), the stem (6) and the key (28).
44	Remove and replace the I/DWR rings (51) from the stem guide (20). ! NOTICE! Before inserting the replacement O-ring, clean the retaining slots with a cleaning solution.
45	Remove the O-rings (36) from the stem guide (20) and replace them, lubricating them with synthetic grease. ! NOTICE! Before inserting the replacement O-ring, clean the retaining slots with a cleaning solution.
46	Remove the O-rings (40, 41) from the stem guide (20) and replace them, lubricating them with synthetic grease. ! NOTICE! Before inserting the replacement O-rings, clean the retaining slots with a cleaning solution.
47	Remove and replace the O-rings (42) from the stem (6), lubricating them with synthetic grease. ! NOTICE! Before inserting the replacement O-rings, clean the retaining slots with a cleaning solution.

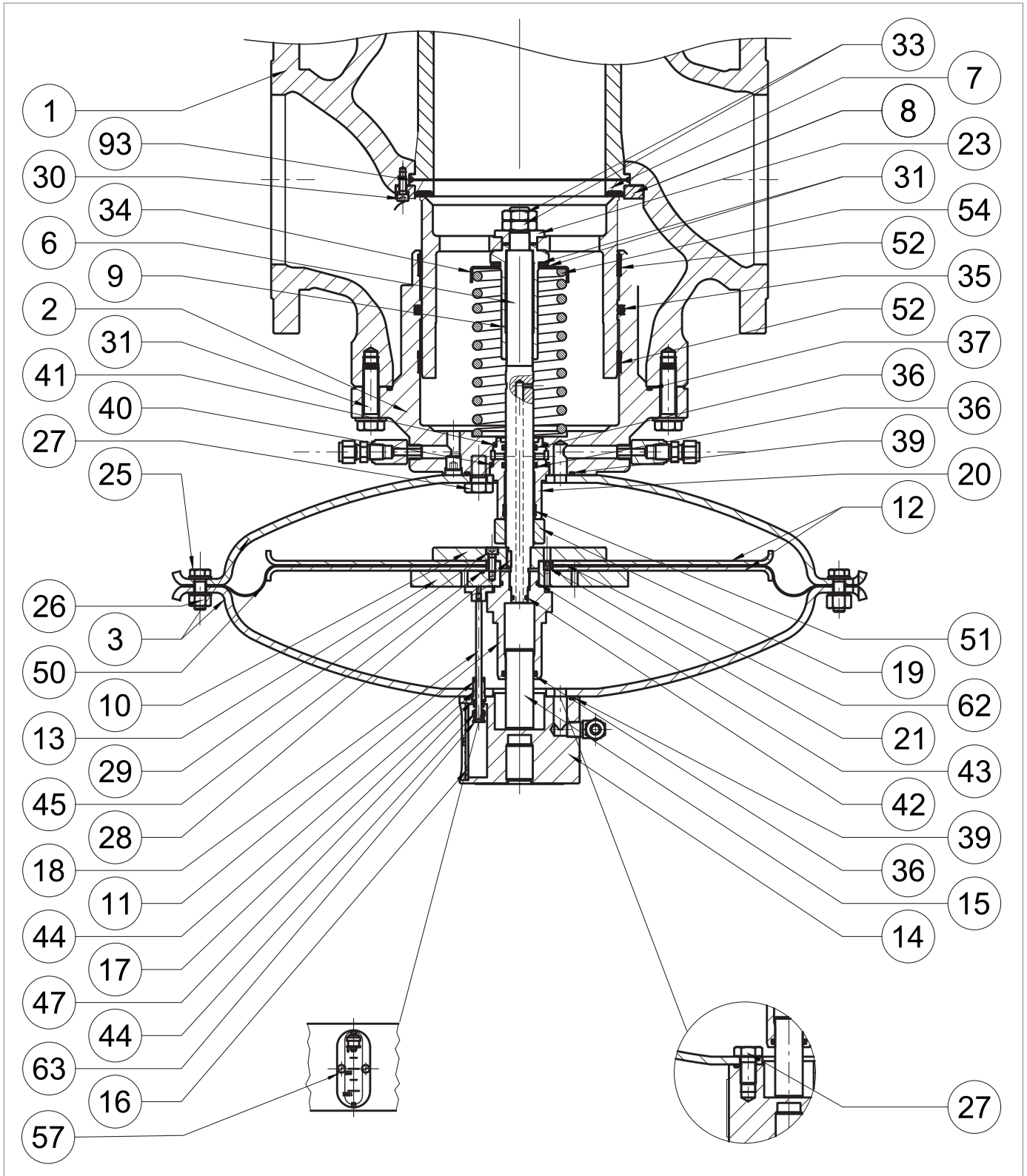

BUILT-IN MONITOR PM/182 6" ÷ 8"

Step	Action
48	<p>Remove the stem guide (20), the stem (6) and the key (28).</p> <div style="border: 1px solid black; padding: 5px;"> <p>NOTICE!</p> <ul style="list-style-type: none"> • Lubricate the stem surface with silicone grease • Make sure that the key (28) is in the correct position in the stem (6) </div>
49	<p>Place the lower cover (3) on the plug guide (2).</p> <div style="border: 1px solid black; padding: 5px;"> <p>NOTICE!</p> <p>Match the hole for the passage of the loading pressure to the similar one on the plug guide.</p> </div>
50	<p>Insert and fasten the screws of the lower part (27) in the lower cover (3) according to the tightening torque:</p> <ul style="list-style-type: none"> • 6": Tab. 9.111 • 8": Tab. 9.112 <div style="border: 1px solid black; padding: 5px;"> <p>NOTICE!</p> <p>Tighten the screws according to the cross diagram in paragraph 9.4.2.2.</p> </div>
51	Put the diaphragm unit in place (10, 12, 13, 21, 29, 45, 50, 62).
52	<p>Insert and secure the balancing stem guide (11) according to the tightening torque:</p> <ul style="list-style-type: none"> • 6": Tab. 9.111 • 8": Tab. 9.112 <div style="border: 1px solid black; padding: 5px;"> <p>NOTICE!</p> <p>During this step, hold the diaphragm assembly in place by positioning the spanner in the holes in the upper diaphragm support (13).</p> </div>
53	<p>Position the upper cover (3), taking care to position the indicator stem (18) in the space between the upper diaphragm support (13) and the balance stem guide (11).</p> <div style="border: 1px solid black; padding: 5px;"> <p>NOTICE!</p> <ul style="list-style-type: none"> • The indicator rod (18) must not obstruct the hole on the upper diaphragm support (13); • The flange travel indicator must be visible and perpendicular to the gas flow </div>
55	<p>Insert and fasten the screws (25) with the nuts (26) according to the tightening torque:</p> <ul style="list-style-type: none"> • 6": Tab. 9.111 • 8": Tab. 9.112 <div style="border: 1px solid black; padding: 5px;"> <p>NOTICE!</p> <p>Tighten the screws according to the cross diagram in paragraph 9.4.2.2.</p> </div>
56	<p>Position the spring holder (34) and spring (54).</p> <div style="border: 1px solid black; padding: 5px;"> <p>NOTICE!</p> <p>Check that the spring (54) is properly seated in the centring stop on the plug guide (2).</p> </div>
57	<p>Insert the locking nut (9) according to the tightening torque:</p> <ul style="list-style-type: none"> • 6": Tab. 9.111 • 8": Tab. 9.112
58	Insert the plug (5).
59	Insert the washer (23).

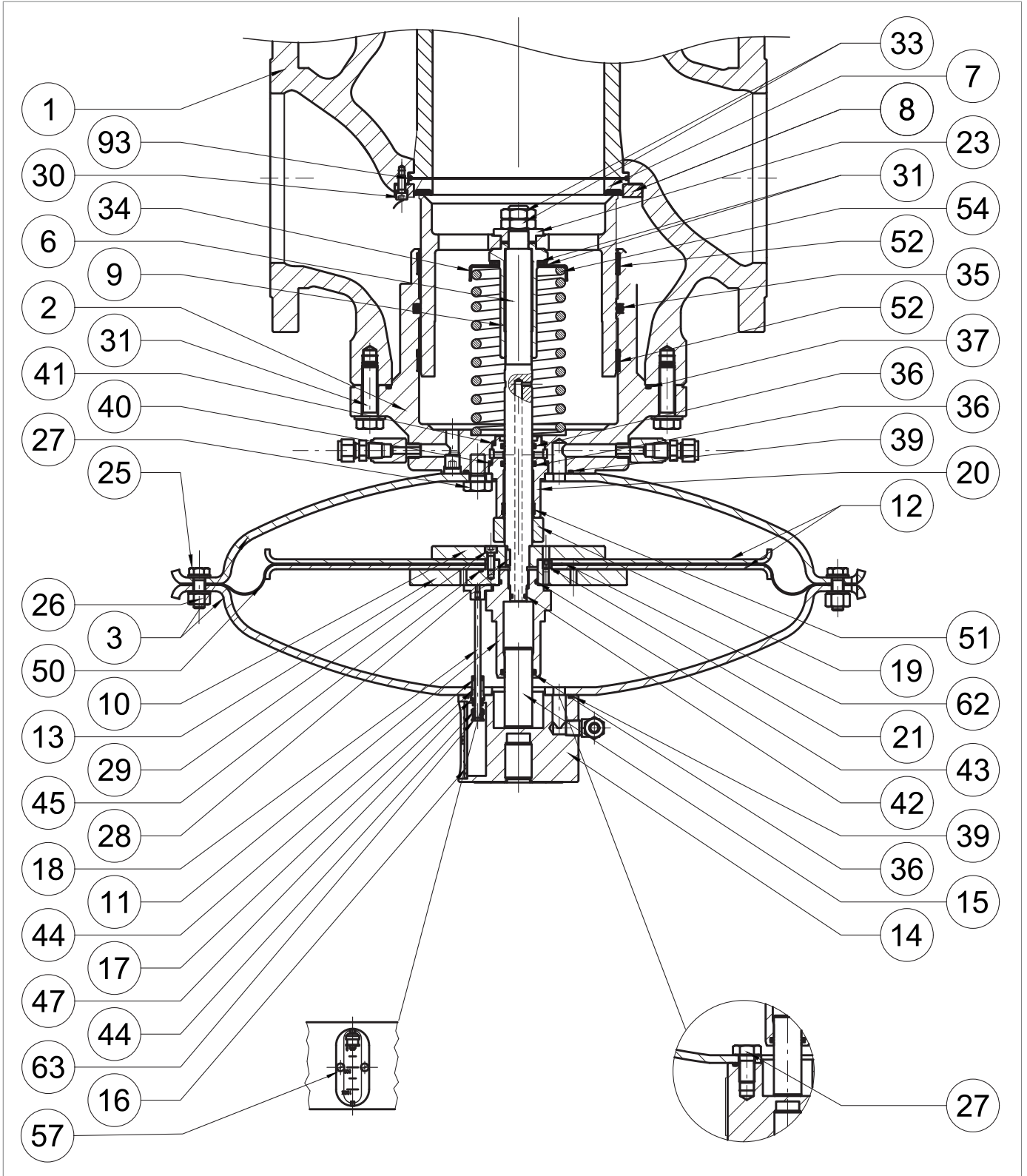

BUILT-IN MONITOR PM/182 6" ÷ 8"

Step	Action
60	<p>Insert and secure the locking nuts (33), applying threadlocking glue, according to the tightening torque:</p> <ul style="list-style-type: none"> • 6": Tab. 9.111 • 8": Tab. 9.112 <p>NOTICE!</p> <p>During this phase, manually compress the spring (54).</p>
64	<p>Unscrew and remove screws (30), shaft collar (8), reinforced gasket (7), conical seat (63) and O-ring (93).</p> <p>NOTICE!</p> <p>Take care that the upper seal does not fall off.</p>
65	<p>Remove the O-ring (93) from the reinforced gasket (7) and replace it, lubricating it with synthetic grease.</p> <p>NOTICE!</p> <p>Before inserting the replacement O-ring, clean the retaining slots with a cleaning solution.</p>
66	<p>Position the reinforced gasket (7), the conical seat (63) and the shaft collar (8).</p>
67	<p>Insert and fix the screws (30) according to the following tightening torque:</p> <ul style="list-style-type: none"> • 6": Tab. 9.111 • 8": Tab. 9.112 <p>NOTICE!</p> <p>Tighten the screws according to the cross diagram in paragraph 9.4.2.2.</p>
70	<p>Position the control head inside the regulator body (1) with the indicator slide (16) visible and on axis with the gas flow direction.</p> <p>NOTICE!</p> <p>Take care not to damage the plug profile (2).</p>
71	<p>Insert and fix the screws (31) according to the following tightening torque:</p> <ul style="list-style-type: none"> • 6": Tab. 9.111 • 8": Tab. 9.112 <p>NOTICE!</p> <p>Tighten the screws according to the cross diagram in paragraph 9.4.2.2.</p>
72	<p>Insert the pawl (163) into the rod (18).</p>
73	<p>Place the indicator slide (16) in the eyebolt flange (14).</p> <p>NOTICE!</p> <p>Check that the pawl (163) is in position 0% in relation to the indicator slide (16).</p>
74	<p>Insert and fasten the position screws (57).</p>
75	<p>Connect the pneumatic connections between the regulator and the respective control unit, including pressure ports downstream.</p>

Tab. 9.153.

WARNING!

Ensure that all parts have been fitted correctly.

9.4.6 - 200/A SERIES PILOT MAINTENANCE + PRE-REGULATORS R31/A AND R14/A

9.4.6.1 - PILOT DISCONNECTION SERIES 201/A AND PRE-REGULATOR R31/A

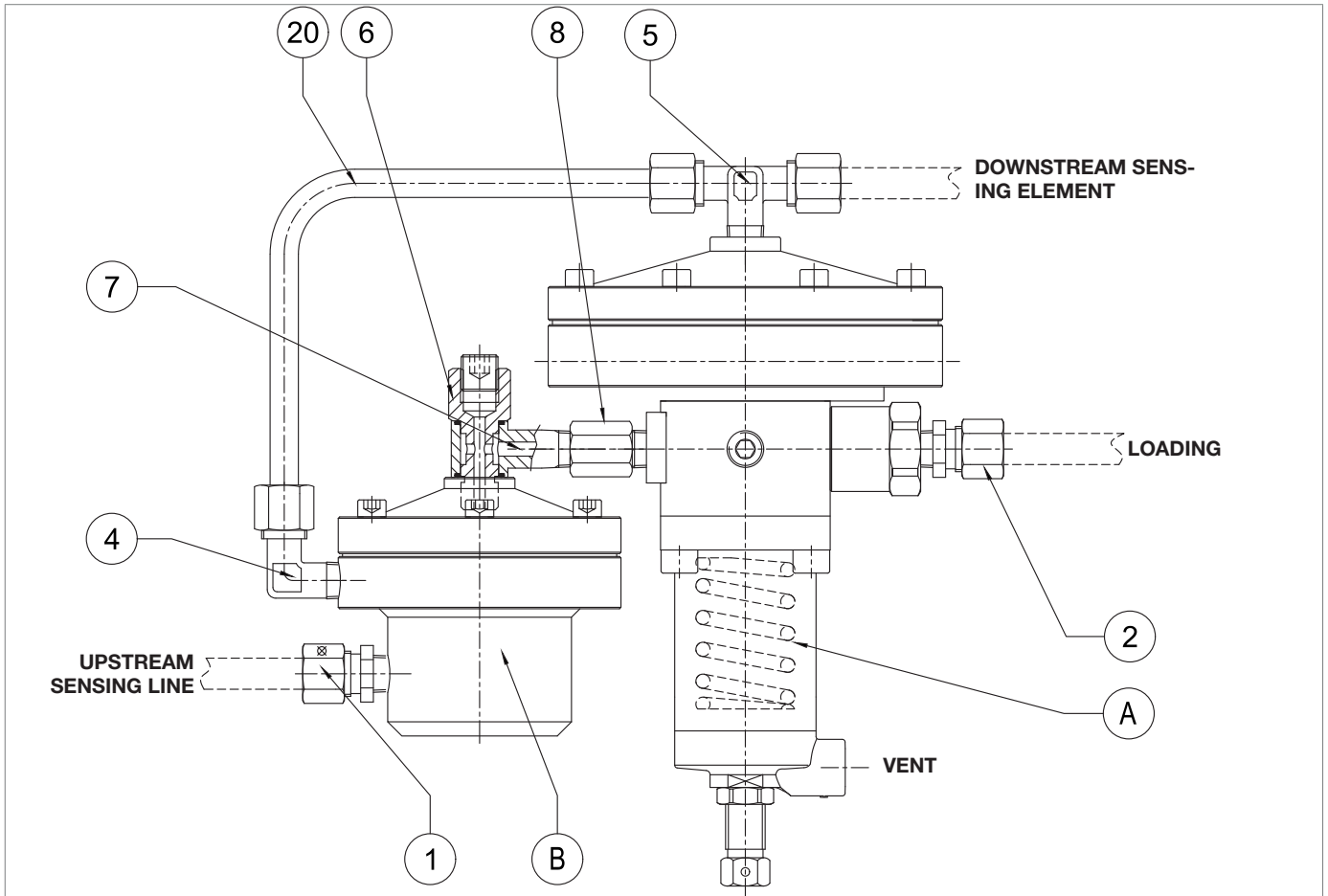

Fig. 9.77. 201/A + R31/A series pilot

To disconnect pilot 201/A, proceed as shown in Tab. 9.154 (see Fig. 9.77):

Step	Action
1	Disconnect the sensing lines between the 201/A pilot and the regulator by adjusting the fittings (1, 2, 3).
2	Unscrew and remove the fixing screw to remove the 201/A pilot from the regulator.
3	Remove the pipe (20) by adjusting the fittings (4, 5).
4	Unscrew and remove screw (6) to separate pre-regulator R31/A from pilot 201/A.
5	Undo and remove the screw (7) from pilot 201/A.

Tab. 9.154.

9.4.6.2 - 204/A SERIES PILOT DISCONNECTION AND R14/A PRE-REGULATOR

Fig. 9.78. 204/A + R14/A series pilot

To disconnect pilot 204/A, proceed as shown in Tab. 9.155 (see Fig. 9.78):

Step	Action
1	Disconnect the sensing lines between the 204/A pilot and the regulator by adjusting the fittings (1, 2, 3).
2	Unscrew and remove the fixing screw to remove the pilot 204/A from the regulator.
3	Remove the pipe (20) by adjusting the fittings (4, 5).
4	Unscrew and remove the screw (6) to separate the R14/A pre-regulator from the pilot 204/A.
5	Undo and remove the screw (7) from pilot 204/A.

Tab. 9.155.

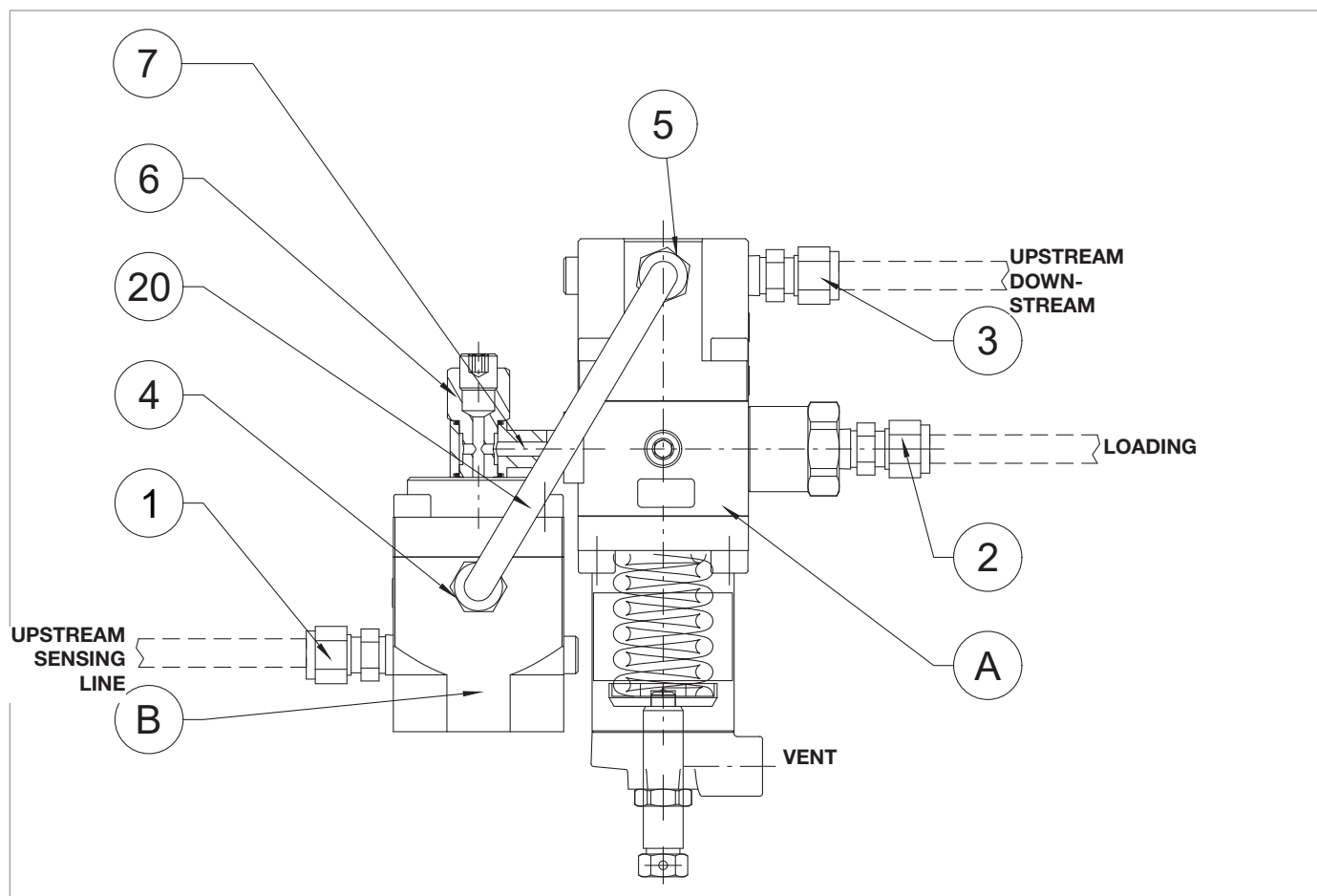
9.4.6.3 - PILOT 201/A

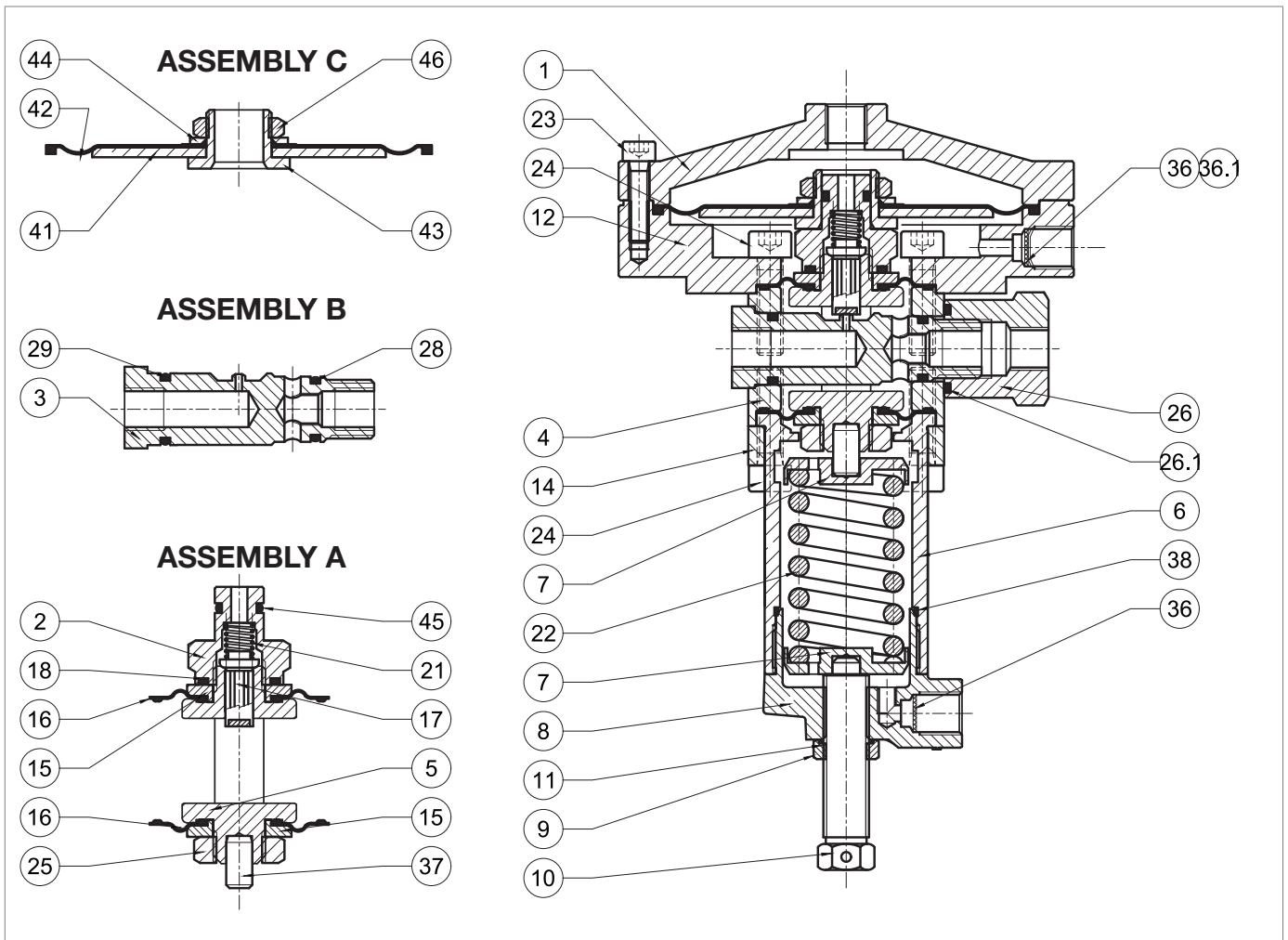





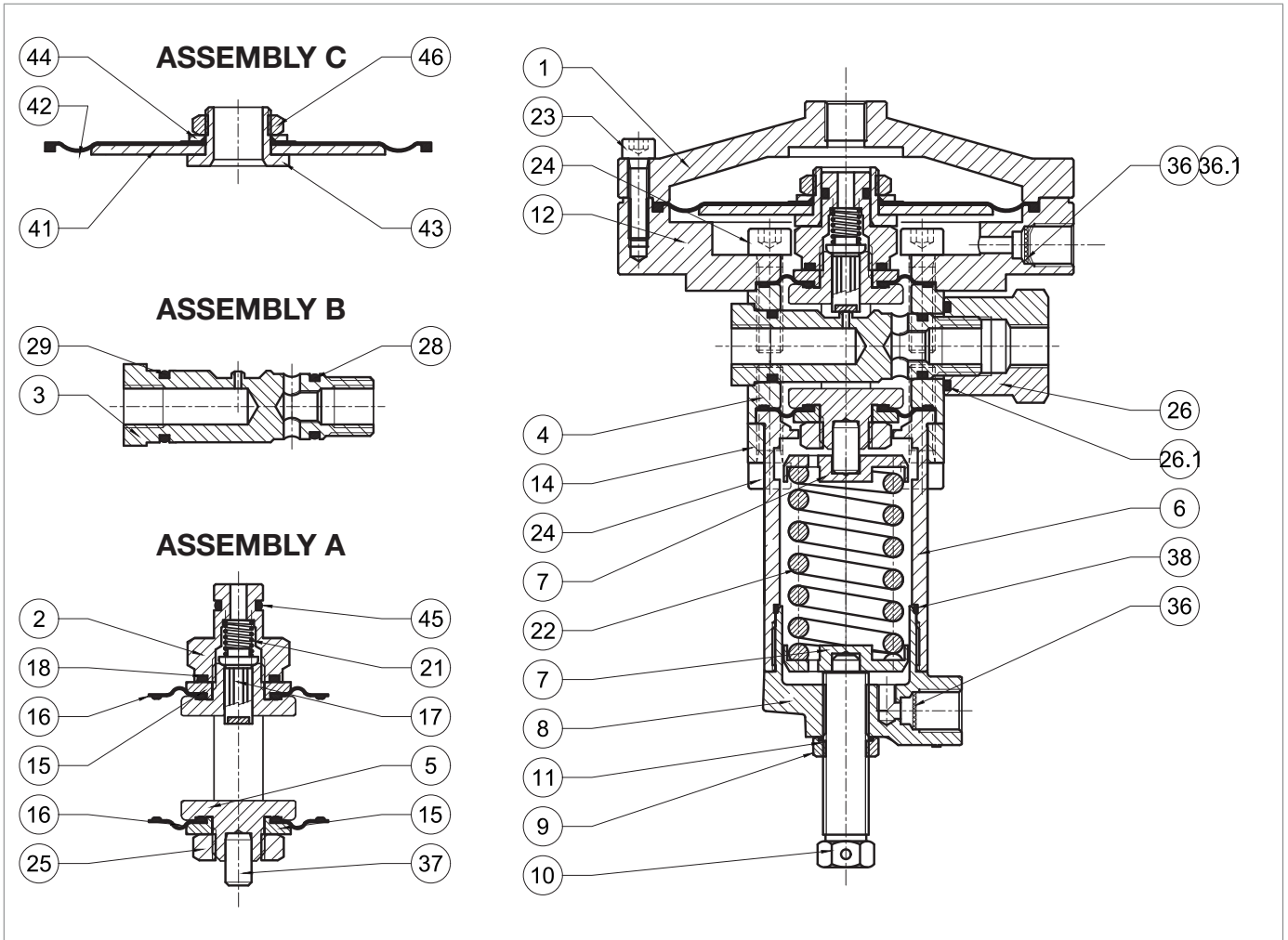





Fig. 9.79. Pilot 201/A

Step	Action
1	Loosen the nut (9).
2	Completely release the spring (22) by turning the adjusting screw (10).
3	Remove the adjusting screw (10) together with the cap (9).
4	Remove the cap (8).
	Remove the O-ring (38) from the cap (8) and replace it, lubricating it with synthetic grease.
5	 NOTICE! Before inserting the replacement O-ring, clean the retaining slots with a cleaning solution.
6	Remove the spring (22) and the spring supports (7).
7	Undo and remove the screws of the lower section (24).
8	Remove the bracket (14) from the sleeve (6).
9	Remove the sleeve (6).
10	Undo and remove the screws (23).
11	Remove the pilot cover (1).
12	Remove the "C" assembly (membrane).
	Unscrew and remove the nut (46) together with the washer (44)
13	 NOTICE! During this operation, hold the diaphragm support (43) in place.
14	Remove and replace the diaphragm (42).
15	Position the washer (44) with the conical part facing the diaphragm.
	Insert and fix the nut (46).
16	 NOTICE! During this operation, hold the diaphragm support (43) in place.
17	Undo and remove the screws of the upper section (24).
18	Remove the flange (12).
19	Unscrew and remove the nut (26).
20	Remove and replace O-ring (26.1) from nut (26)
21	Pull out the "B" (valve) assembly.
	Remove the O-rings (28, 29) from the valve seat (3) and replace them, lubricating them with synthetic grease.
22	 NOTICE! Before inserting the replacement O-rings, clean the retaining slots with a cleaning solution.
23	Remove assembly "A" (plug) from the valve body (4) by pushing it from the top downwards.
24	Unscrew and remove the pilot nut (2).
	Remove the O-ring (18) of the pilot nut (2) and replace it, lubricating it with synthetic grease.
25	 NOTICE! Before inserting the replacement O-rings, clean the retaining slots with a cleaning solution.
26	Remove the spring (21).
27	Remove and replace the plug (17).



Pilot 201/A

Step	Action
28	Remove the upper protection disc (15).
29	Remove and replace the upper diaphragm (16), lubricating the lanyards with synthetic grease. <div style="border: 1px solid black; padding: 2px;">  NOTICE! Before inserting the replacement diaphragm, clean the retaining slots with a cleaning solution. </div>
30	Unscrew and remove the nut (25).
31	Remove the lower protection disc (15).
32	Remove and replace the lower diaphragm (16), lubricating the lanyards with synthetic grease. <div style="border: 1px solid black; padding: 2px;">  NOTICE! Before inserting the replacement diaphragm, clean the retaining slots with a cleaning solution. </div>
33	Fit the lower protection disc (15).
34	Fix the nut (25) according to the following tightening torque: <ul style="list-style-type: none"> • Pilot 201/A: Tab. 9.113
35	Fit the plug (17) and then the spring (21).
36	Fit the upper protection disc (15).
37	Fix the nut (2) according to the following tightening torque: <ul style="list-style-type: none"> • Pilot 201/A: tab.9.114
38	Insert assembly "A" (plug) from top to bottom into the valve body (4). <div style="border: 1px solid black; padding: 2px;">  NOTICE! <ul style="list-style-type: none"> • Take care not to damage the diaphragms (16) during this step • Make sure the marking on the lower section of the headframe is parallel to the axis of the hole for inserting the seat (3) into the valve body (4). </div>
39	Insert assembly "B" (valve) into the valve body (4). <div style="border: 1px solid black; padding: 2px;">  NOTICE! Take care not to damage the O-rings (28, 29) and the valve seat (3). </div>
40	Insert and fix the nut (26) according to the following tightening torque: <ul style="list-style-type: none"> • Pilot 201/A: Tab. 9.113
41	Position the upper diaphragm (16).
42	Position the upper disc (15).
43	Insert the plug (17).
44	Fit the spring (21).
45	Insert and fix the nut (2) according to the following tightening torque: <ul style="list-style-type: none"> • Pilot 201/A: Tab. 9.113
46	Fit the flange (12).
47	Insert and fix the screws (24) according to the following tightening torque: <ul style="list-style-type: none"> • Pilot 201/A: Tab. 9.113
48	Place the assembly "C" (membrane).
49	Position cover (1).

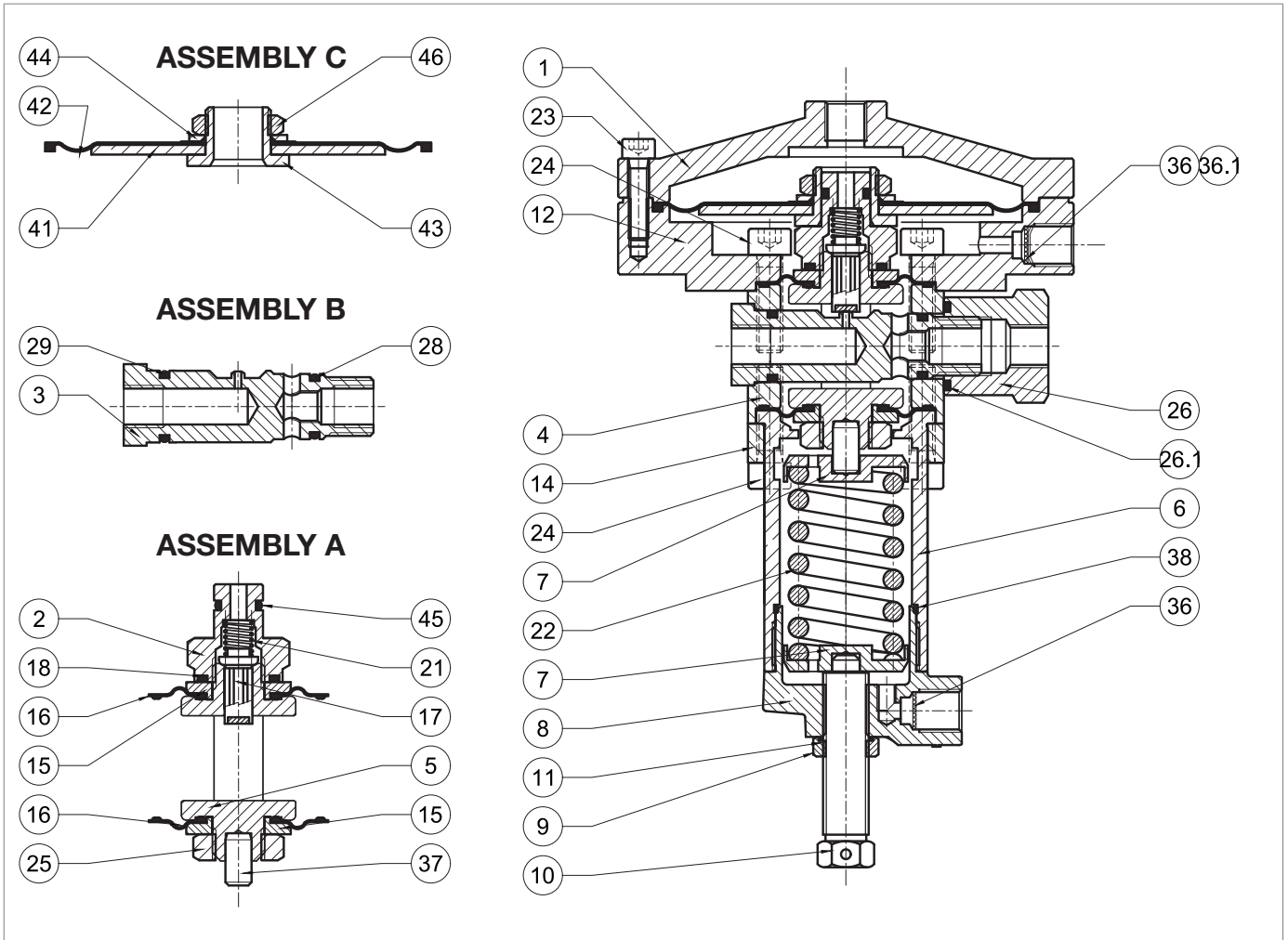

Pilot 201/A

Step	Action
50	Insert and fix the screws (23) according to the following tightening torque: <ul style="list-style-type: none"> Pilot 201/A: Tab. 9.113
51	Fit the sleeve (6).
52	Position the bracket (14) in the sleeve (6).
53	Insert and fix the screws of the lower section (24) according to the following tightening torque: <ul style="list-style-type: none"> Pilot 201/A: Tab. 9.113
54	Insert the upper spring guide (7).
55	Insert the spring (22).
56	Insert the lower spring guide (7).
57	Unscrew the cap (8).
58	Remove the O-ring (11) from the nut (9) and replace it, lubricating it with synthetic grease. <div style="border: 1px solid black; padding: 5px; margin-top: 5px;"> <p>! NOTICE! Before inserting the replacement O-ring, clean the retaining slots with a cleaning solution.</p> </div>
59	Place the nut (9) in the adjusting screw (10).
60	Insert the adjusting screw (10) into the cap (8).

Tab. 9.156.

! WARNING!

Ensure that all parts have been fitted correctly.

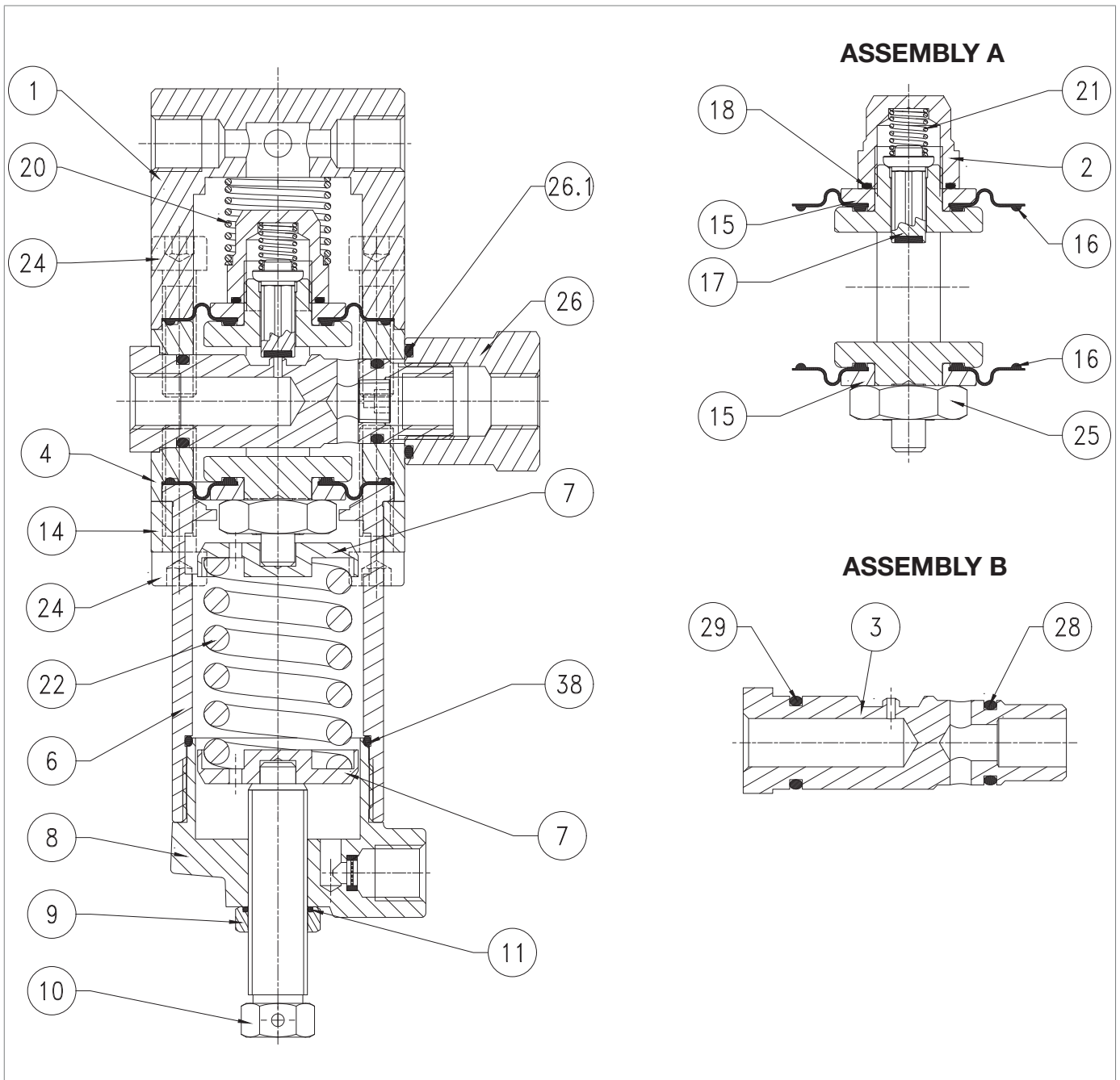

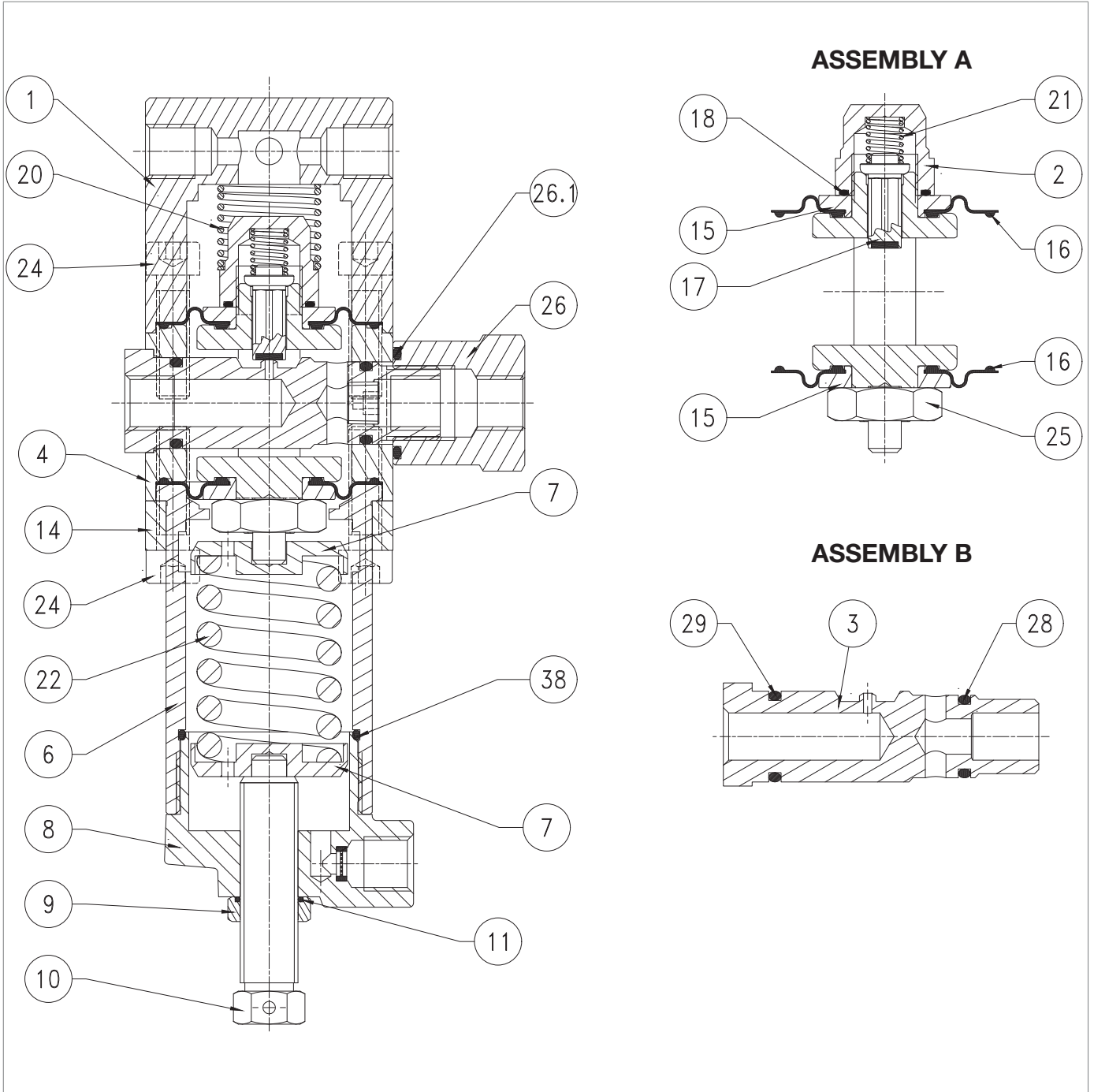

Fig. 9.80. Pilot 204/A

Step	Action
1	Loosen the nut (9).
2	Completely release the spring (22) by turning the adjusting screw (10).
3	Remove the adjusting screw (10) together with the cap (9).
4	Remove the cap (8).
	Remove the O-ring (38) from the cap (8) and replace it, lubricating it with synthetic grease.
5	 NOTICE! Before inserting the replacement O-ring, clean the retaining slots with a cleaning solution.
6	Remove the spring (22) and the spring supports (7).
7	Undo and remove the screws of the lower section (24).
8	Remove the bracket (14) from the sleeve (6).
9	Remove the sleeve (6).
10	Undo and remove the screws of the upper section (24).
11	Remove the pilot cover (1).
12	Remove the spring (20).
13	Unscrew and remove the nut (26).
	Remove the O-ring (26.1) from the nut (26) and replace it, lubricating it with synthetic grease.
14	 NOTICE! Before inserting the replacement O-ring, clean the retaining slots with a cleaning solution.
15	Pull out the "B" (valve) assembly.
	Remove the O-rings (28, 29) from the valve seat (3) and replace them, lubricating them with synthetic grease.
16	 NOTICE! Before inserting the replacement O-ring, clean the retaining slots with a cleaning solution.
17	Remove assembly "A" (plug) from the valve body (4) by pushing it from the top downwards.
18	Unscrew and remove the pilot nut (2).
	Remove the O-ring (18) of the pilot nut (2) and replace it, lubricating it with synthetic grease.
19	 NOTICE! Before inserting the replacement O-ring, clean the retaining slots with a cleaning solution.
20	Remove the spring (21).
21	Remove and replace the plug (17).
22	Remove the upper protection disc (15).
	Remove and replace the upper diaphragm (16), lubricating the lanyards with synthetic grease.
23	 NOTICE! Before inserting the replacement diaphragm, clean the retaining slots with a cleaning solution.
24	Unscrew and remove the nut (25).
25	Remove the lower protection disc (15).



Pilot 204/A

Step	Action
26	Remove and replace the lower diaphragm (16), lubricating the lanyards with synthetic grease. NOTICE! Before inserting the replacement diaphragm, clean the retaining slots with a cleaning solution.
27	Fit the lower protection disc (15).
28	Fix the nut (25) according to the following tightening torque: • Pilot 204/A: Tab. 9.114
29	Fit the plug (17) and then the spring (21).
30	Fit the upper protection disc (15).
31	Fix the pilot nut (2) according to the following tightening torque: • Pilot 204/A: Tab. 9.114
32	Insert assembly "A" (plug) from top to bottom into the valve body (4). NOTICE! • Take care not to damage the diaphragms (16) during this step • Make sure the marking on the lower section of the headframe is parallel to the axis of the hole for inserting the seat (3) into the valve body (4).
33	Insert assembly "B" (valve) into the valve body (4). NOTICE! Take care not to damage the O-rings (28, 29) and the valve seat (3).
34	Fix the nut (26) according to the following tightening torque: • Pilot 204/A: Tab. 9.114
35	Fit the spring (20).
36	Fit the cover (1).
37	Insert and fix the screws of the upper section (24) according to the following tightening torque: • Pilot 204/A: Tab. 9.114
38	Fit the sleeve (6) and the bracket (14).
39	Insert and fix the screws of the lower section (24) according to the following tightening torque: • Pilot 204/A: Tab. 9.114
40	Fit the spring (22) and the spring supports (7).
41	Unscrew the cap (8).
42	Remove and replace the O-ring (11) in the nut (9). NOTICE! Before inserting the replacement O-ring, clean the retaining slots with a cleaning solution.
43	Fit the adjusting screw (10) together with the cap (9).

Tab. 9.157.

WARNING!

Ensure that all parts have been fitted correctly.

9.4.6.5 - PRE-REGULATOR R31/A

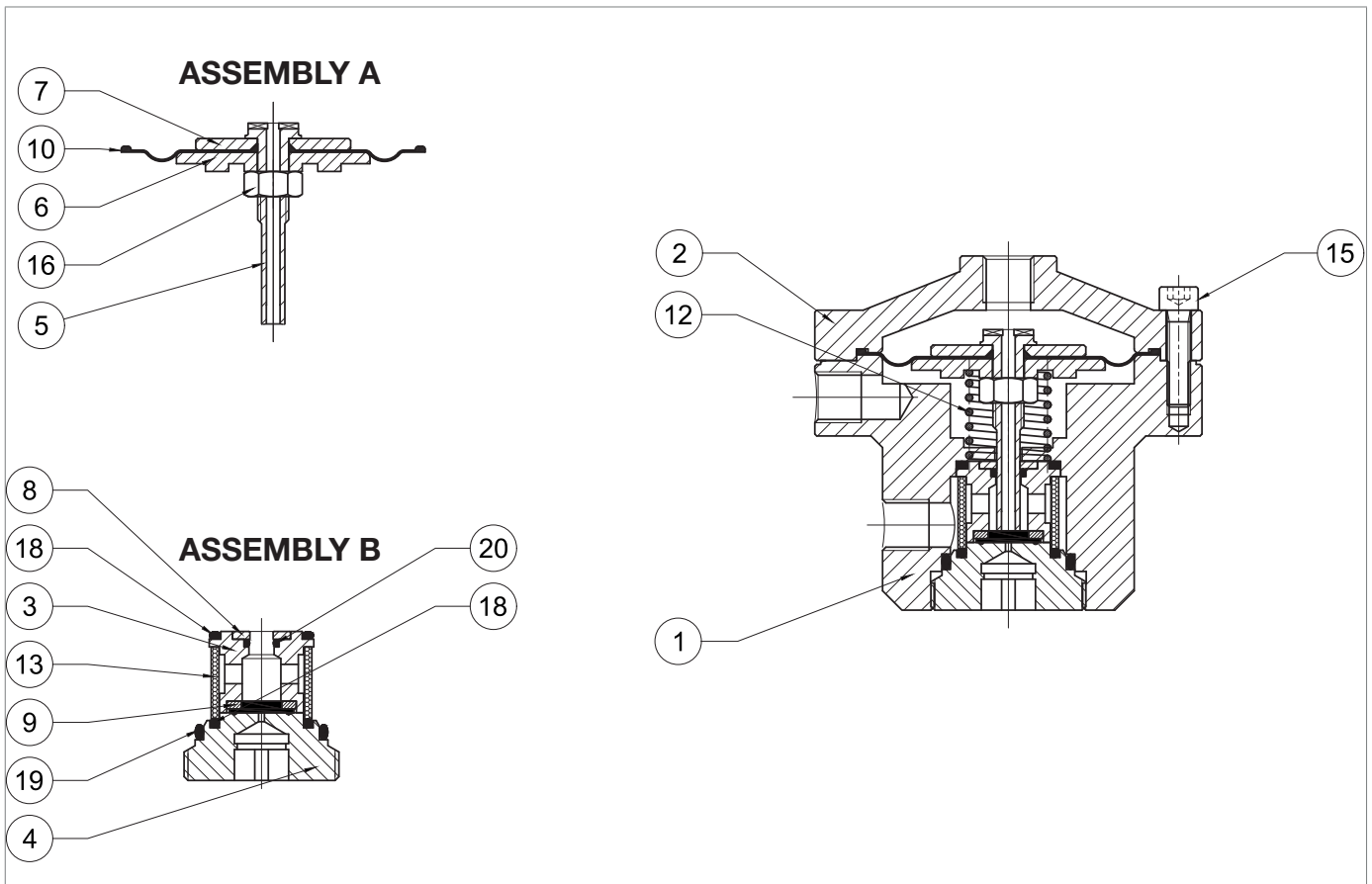







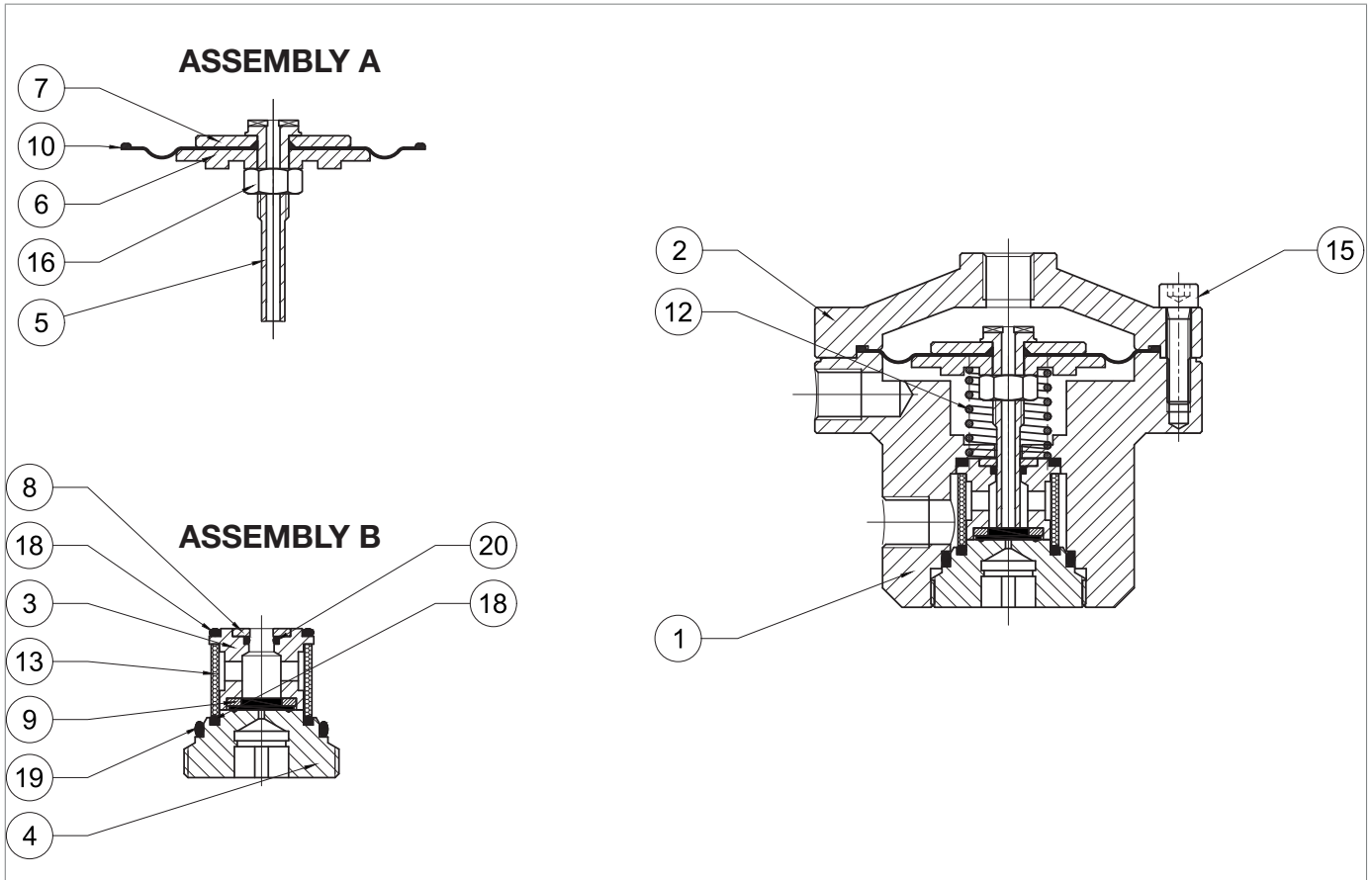

Fig. 9.81. Pre-regulator R31/A

Step	Action
1	Undo and remove the screws (15).
2	Remove the cover (2)
3	Pull out the "A" (plug) assembly.
4	Remove the spring (12).
5	Unscrew and remove the nut (16). <div style="border: 1px solid black; padding: 5px;">  NOTICE! During this phase, hold the plug (5) still. </div>
6	Insert the diaphragm protection disc (6) and the diaphragm (10).
7	Remove and replace the gasket (10). <div style="border: 1px solid black; padding: 5px;">  NOTICE! Before inserting the replacement diaphragm, clean the retaining slots with a cleaning solution. </div>
8	Fit the diaphragm protection disc (6).
9	Fit and fix the nut (16) into the plug (5) according to the following tightening torque: <ul style="list-style-type: none"> R31/A: Tab. 9.115 <div style="border: 1px solid black; padding: 5px;">  NOTICE! During this phase, hold the plug (5) still. </div>
10	Unscrew and remove assembly "B" (cap) by adjusting the cap (4).
11	Take out the plug guide (3).
12	Remove the O-ring (18) from the plug guide (3) and replace it, lubricating it with synthetic grease. <div style="border: 1px solid black; padding: 5px;">  NOTICE! Before inserting the replacement O-ring, clean the retaining slots with a cleaning solution. </div>
13	Remove the plug guide ring (8).
14	Remove the O-ring (20) from the plug guide (3) and replace it, lubricating it with synthetic grease. <div style="border: 1px solid black; padding: 5px;">  NOTICE! Before inserting the replacement O-ring, clean the retaining slots with a cleaning solution. </div>
15	Remove and replace the reinforced gasket (9). <div style="border: 1px solid black; padding: 5px;">  NOTICE! Before inserting the replacement O-ring, clean the retaining slots with a cleaning solution. </div>
16	Remove and replace the filter (13).
17	Remove the O-rings (18, 19) from the cap (4) and replace them, lubricating them with synthetic grease. <div style="border: 1px solid black; padding: 5px;">  NOTICE! Before inserting the replacement O-rings, clean the retaining slots with a cleaning solution. </div>
18	Put the filter (13) and the plug guide (3) in place.



Pre-regulator R31/A

Step	Action
19	Position the plug guide ring (8).
20	Place assembly "B" (cap) in the body (1). ! NOTICE! Take care not to damage the O-rings (18, 19) during this step.
21	Secure the "B" (cap) assembly by adjusting the cap (4) according to the tightening torque: • R31/A: Tab. 9.115
22	Fit the spring (12).
23	Insert assembly "A" (plug) into the body (1). ! NOTICE! Before inserting the plug unit, lubricate the plug surface with silicone grease.
24	Fit the cover (2).
25	Insert and fix the screws (15) according to the following tightening torque: • R31/A: Tab. 9.115 ! NOTICE! Tighten the screws according to the cross diagram in paragraph 9.4.2.2.

Tab. 9.158.

! WARNING!

Ensure that all parts have been fitted correctly.

9.4.6.6 - PRE-REGULATOR R14/A

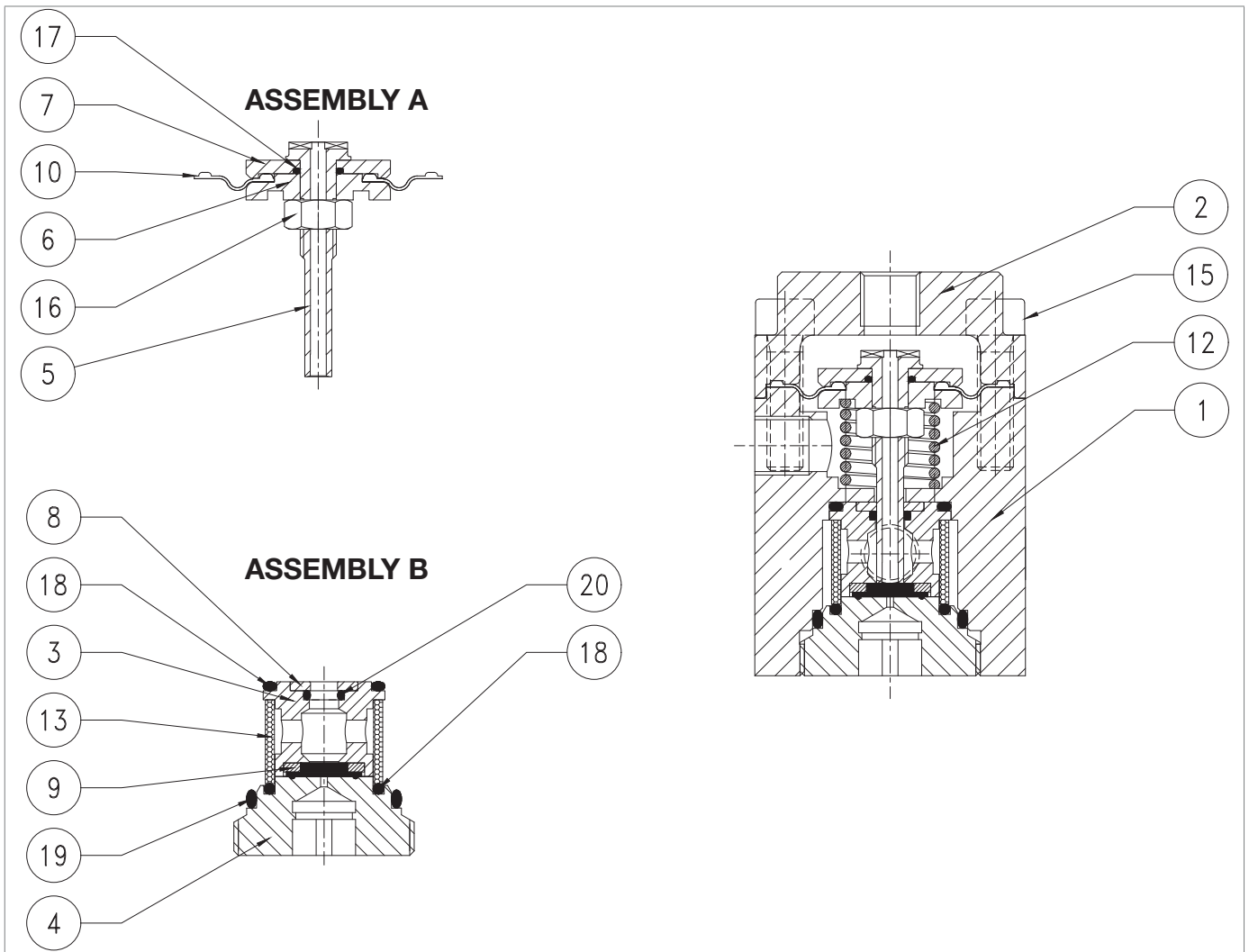
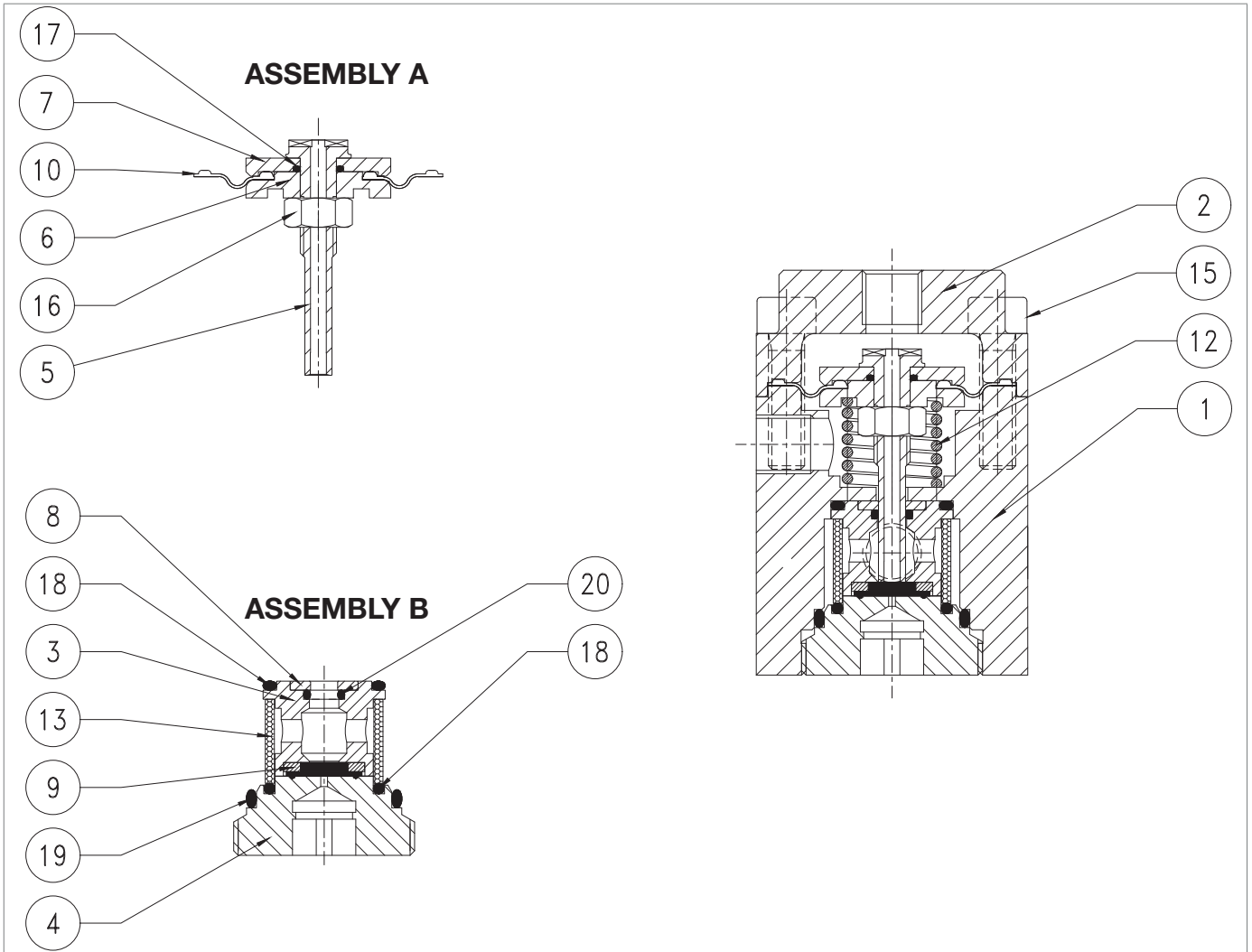

Fig. 9.82. Pre-regulator R14/A

Step	Action
1	Undo and remove the screws (15).
2	Remove the cover (2)
3	Pull out the "A" (plug) assembly.
4	Remove the spring (12).
5	Unscrew and remove the nut (16).
6	Insert the diaphragm protection disc (6) and the diaphragm (10).
7	Remove and replace the O-ring (17) from the diaphragm protection disc (7), lubricating it with synthetic grease. <div style="border: 1px solid black; padding: 5px;">! NOTICE! Before inserting the replacement O-ring, clean the retaining slots with a cleaning solution.</div>
8	Remove and replace the gasket (10). <div style="border: 1px solid black; padding: 5px;">! NOTICE! Before inserting the replacement diaphragm, clean the retaining slots with a cleaning solution.</div>
9	Fit the diaphragm protection disc (7).
10	Fit and fix the nut (16) into the plug (5) according to the following tightening torque: <ul style="list-style-type: none"> • R14/A: Tab. 9.116
11	Unscrew and remove assembly "B" (cap) by adjusting the cap (4).
12	Take out the plug guide (3).
13	Remove the O-ring (18) from the plug guide (3) and replace it, lubricating it with synthetic grease. <div style="border: 1px solid black; padding: 5px;">! NOTICE! Before inserting the replacement O-ring, clean the retaining slots with a cleaning solution.</div>
14	Remove the plug guide ring (8).
15	Remove the O-ring (20) from the plug guide (3) and replace it, lubricating it with synthetic grease. <div style="border: 1px solid black; padding: 5px;">! NOTICE! Before inserting the replacement O-ring, clean the retaining slots with a cleaning solution.</div>
16	Remove and replace the reinforced gasket (9). <div style="border: 1px solid black; padding: 5px;">! NOTICE! Before inserting the replacement O-ring, clean the retaining slots with a cleaning solution.</div>
17	Remove and replace the filter (13).
18	Remove the O-rings (18, 19) from the cap (4) and replace them, lubricating them with synthetic grease. <div style="border: 1px solid black; padding: 5px;">! NOTICE! Before inserting the replacement O-rings, clean the retaining slots with a cleaning solution.</div>
19	Put the filter (13) and the plug guide (3) in place.



Pre-regulator R14/A

Step	Action
20	Position the plug guide ring (8).
21	Position and secure the "B" assembly (cap). ! NOTICE! Take care not to damage the O-rings (18, 19) during this step.
22	Fit the spring (12).
23	Insert assembly "A" (plug) into the body (1). ! NOTICE! Before inserting the plug unit, lubricate the plug surface with silicone grease.
24	Fit the cover (2).
25	Insert and fix the screws (15) according to the following tightening torque: • R14/A: Tab. 9.116 ! NOTICE! Tighten the screws according to the cross diagram in paragraph 9.4.2.2.

Tab. 9.159.

! WARNING!

Ensure that all parts have been fitted correctly.

9.4.6.7 - PILOT RECONNECTION SERIES 201/A AND PRE-REGULATOR R31/A

Fig. 9.83. Pilot 201/A and pre-regulator R31/A

To reconnect the 201/A pilot, proceed as indicated in Tab. 9.160 (see Fig. 9.83):

Step	Action
1	Insert and fix the screw (7) to the 201/A pilot.
2	Insert and fasten the screw (6) to connect the pre-regulator R31/A to the pilot 201/A.
3	Connect the pipe (20) by adjusting the fittings (4, 5).
4	Insert and fasten the fastening screw to connect the 201/A pilot to the regulator.
5	Connect the sensing lines between the 201/A pilot and the regulator by adjusting the fittings (1, 2, 3).

Tab. 9.160.

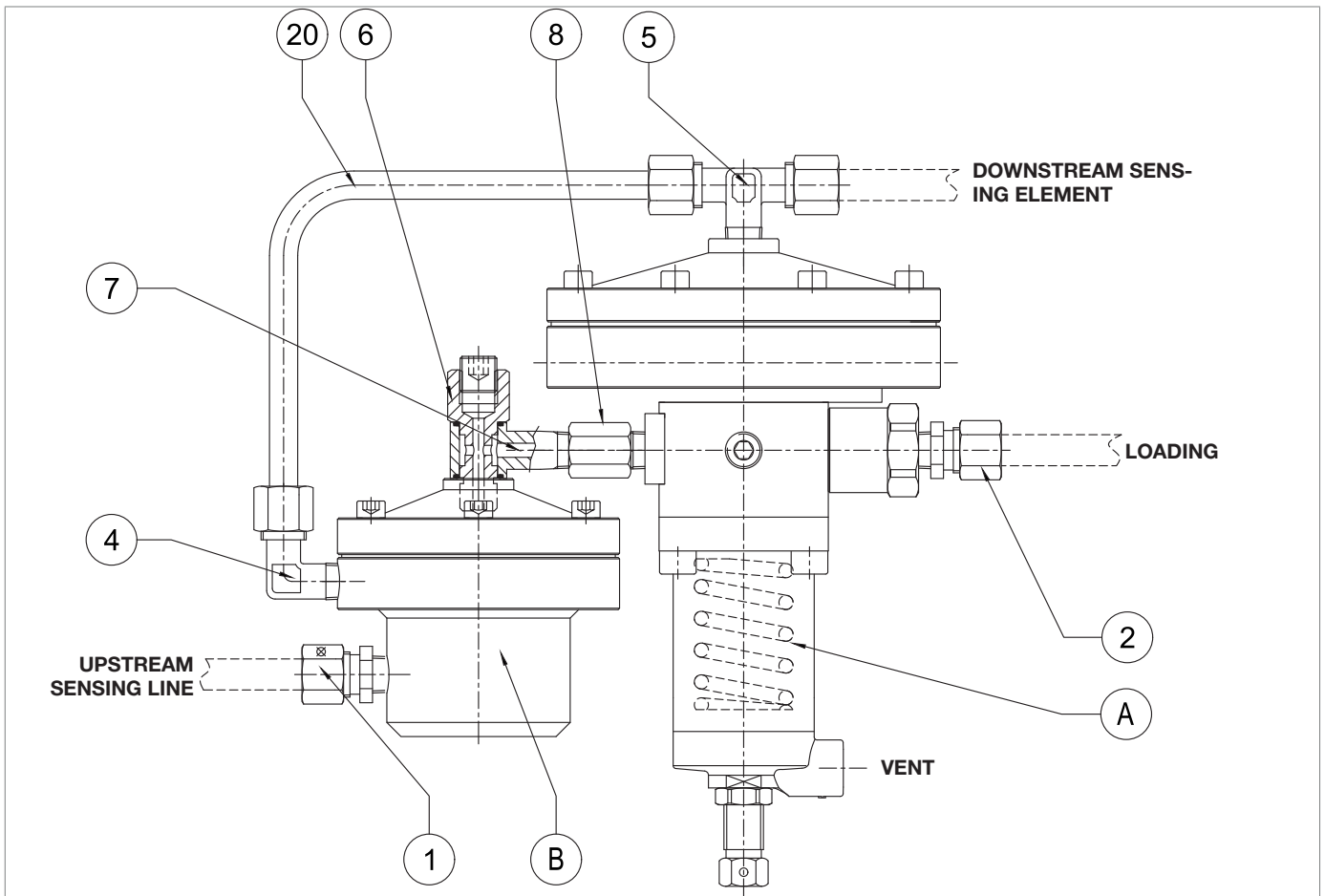
9.4.6.8 - PILOT RECONNECTION SERIES 204/A AND PRE-REGULATOR R14/A

Fig. 9.84. Series 204/A pilot and R14/A pre-regulator

To reconnect the 204/A pilot, proceed as indicated in Tab. 9.161 (see Fig. 9.84):

Step	Action
1	Insert and fix the screw (7) to the 204/A pilot.
2	Insert and fix the screw (6) to connect the R14/A pre-regulator to the 204/A pilot.
3	Connect the pipe (20) by adjusting the fittings (4, 5).
4	Insert and fasten the fixing screw to connect the 204/A pilot to the regulator.
5	Connect the sensing lines between the 204/A pilot and the regulator by adjusting the fittings (1, 2, 3).

Tab. 9.161.

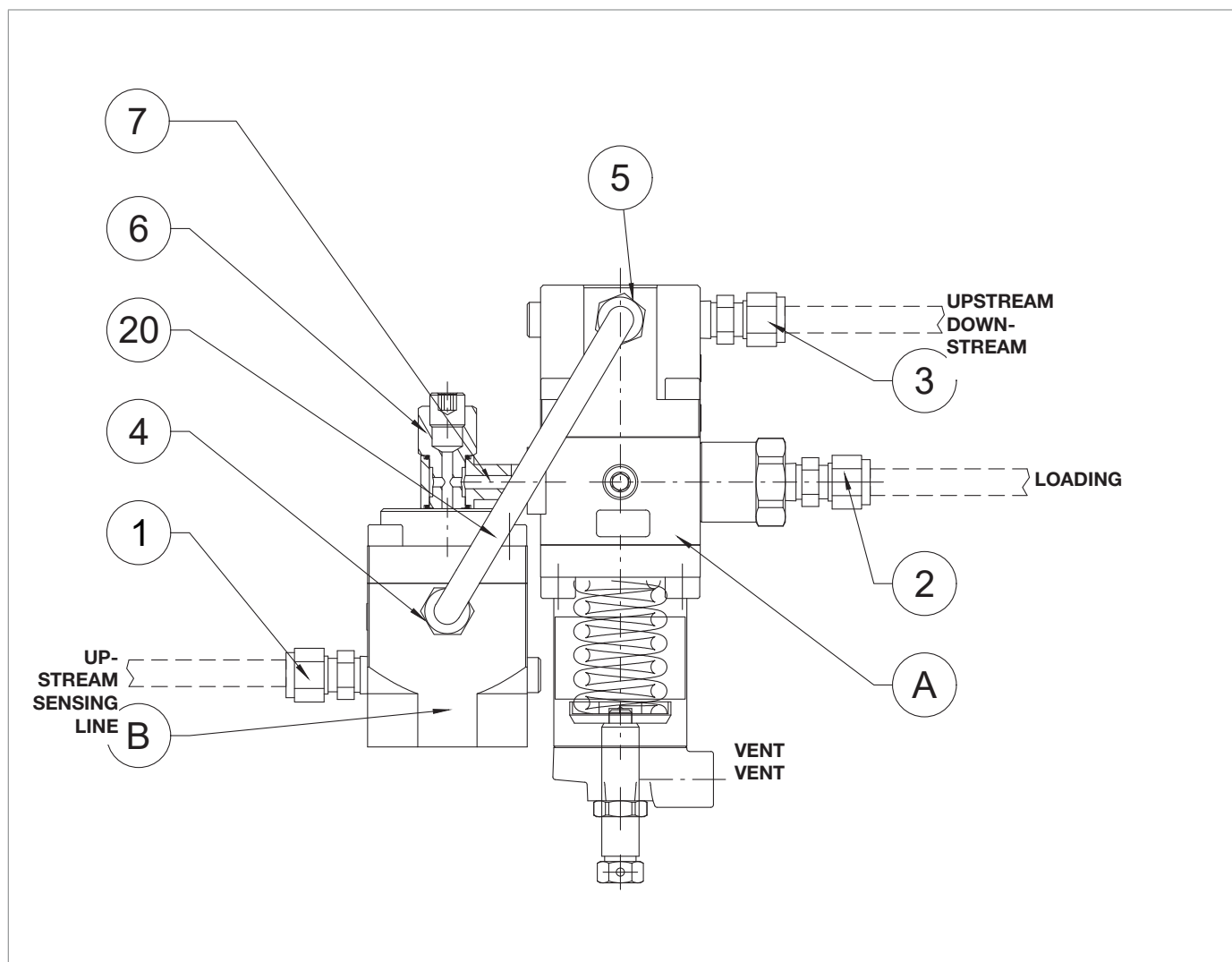
9.4.7 - V/25 THROTTLE VALVE MAINTENANCE

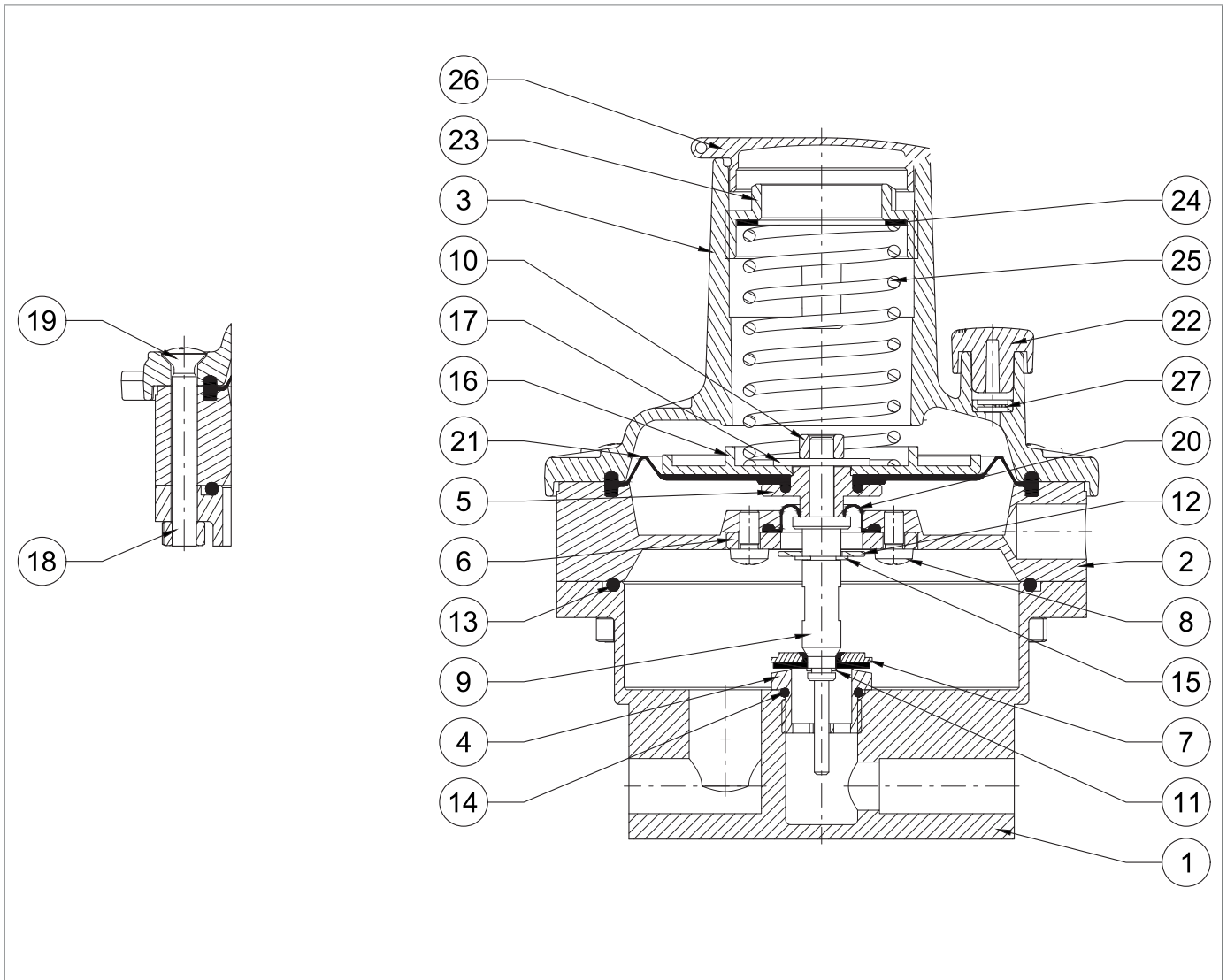
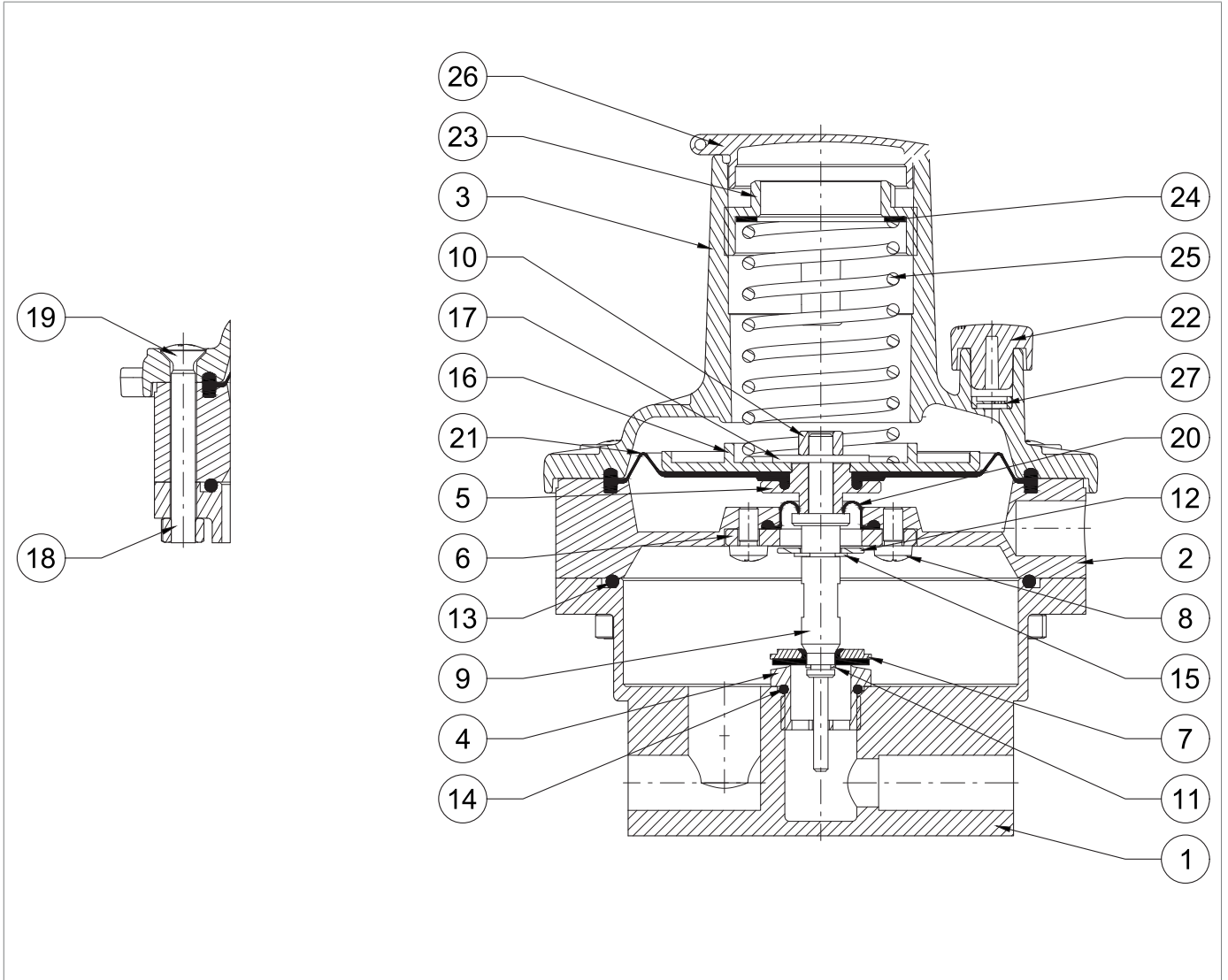



Fig. 9.85. V/25 throttle valve

Step	Action
1	Unscrew and remove the cap (26).
2	Unscrew and remove the calibration ring nut (23) together with the sliding disc (24).
3	Remove the calibration spring (25).
4	Unscrew and remove the screw (19) together with the nut (18).
5	Remove the cover (3). NOTICE! Check that the vent (22, 27) is free of impurities.
6	Remove the diaphragm assembly together with the intermediate flange (2) from the body (1). NOTICE! Check that the atmospheric exhaust is free of impurities.
7	Remove the O-ring (13) and replace it, taking care to lubricate it with synthetic grease. NOTICE! Before inserting the replacement O-ring, clean the retaining slots with a cleaning solution.
8	Unscrew and remove the valve seat (4) from the body (1). NOTICE! During this step, take care not to damage the valve seat (4).
9	Remove the O-ring (14) and replace it, taking care to lubricate it with synthetic grease. NOTICE! Before inserting the replacement O-ring, clean the retaining slots with a cleaning solution.
10	Insert and secure the valve seat (4) in the body (1). NOTICE! During this step, take care not to damage the valve seat (4).
11	Remove the seeger ring (11).
12	Remove the reinforced gasket (7).
13	Unscrew and remove the nut (10), holding the stem (9) in place.
14	Remove the diaphragm holder disc (16).
15	Remove the diaphragm (21) from the diaphragm holder (5). NOTICE! Before inserting the replacement diaphragm, clean the retaining slots with a cleaning solution.
16	Remove the seeger ring (15).
17	Unscrew and remove the screws (8).
18	Remove the disc (6).
19	Remove and replace the diaphragm (20). NOTICE! Before inserting the replacement diaphragm, clean the retaining slots with a cleaning solution.
20	Position the disc (6).



V/25 throttle valve

Step	Action
21	Insert and fasten the screws (8). <div style="border: 1px solid black; padding: 5px;">  NOTICE! Tighten the screws according to the cross diagram in paragraph 9.4.2.2. </div>
22	Insert the seeger ring (15).
23	Replace the reinforced gasket (7).
24	Insert the seeger ring (11).
25	Place the diaphragm (21) in the diaphragm holder (5).
26	Position the diaphragm disc (16).
27	Position the nut (10), holding the stem (9) in place.
28	Insert the diaphragm assembly together with the intermediate flange (2) into the body (1).
29	Fit the cover (3).
30	Insert the screws (19) together with the nut (18). <div style="border: 1px solid black; padding: 5px;">  NOTICE! Tighten the screws according to the cross diagram in paragraph 9.4.2.2. </div>
31	Insert the calibration spring (25).
32	Position the sliding disc (24).
33	Insert and screw in the calibration ring nut (23).
34	Insert and screw in the cap (26).

Tab. 9.162.

 **WARNING!**

Ensure that all parts have been fitted correctly.

9.4.8 - M/A ACCELERATING VALVE MAINTENANCE

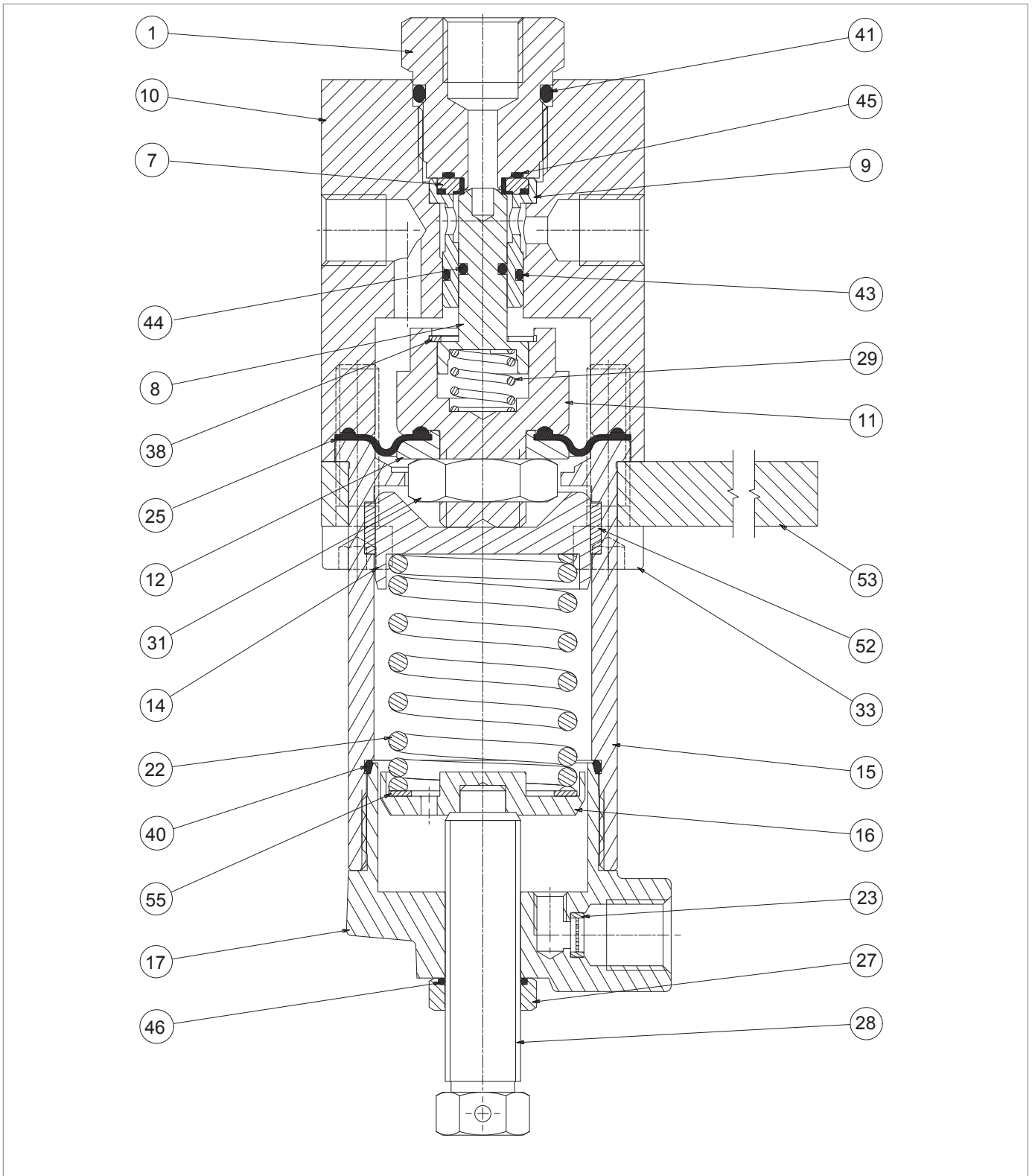





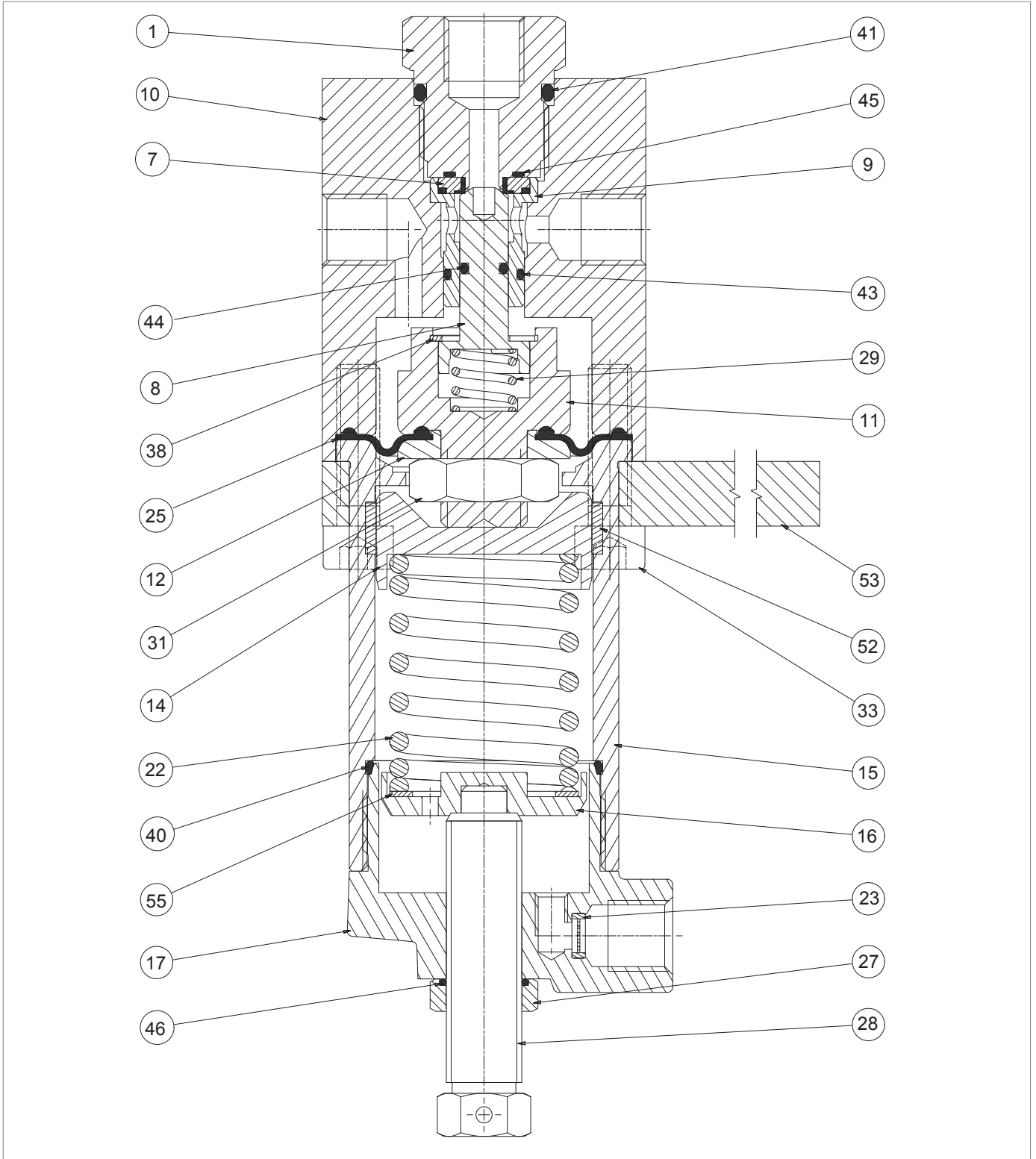





Fig. 9.86. M/A accelerating valve

Step	Action
1	Loosen the nut (27).
2	Completely release the spring (22) by turning the adjusting screw (28).
3	Remove the adjusting screw (28) together with the nut (27).
4	Remove the cap (17).
	Remove the O-ring (40) from the cap (17) and replace it, lubricating it with synthetic grease.
5	 NOTICE! Before inserting the replacement O-ring, clean the retaining slots with a cleaning solution.
6	Remove the lower spring support (16) together with the ring (55).
7	Remove the spring (22).
8	Remove the upper spring support (14).
9	Undo and remove the screws of the lower section (33).
10	Remove the bracket (53) from the sleeve (15).
11	Remove the sleeve (15).
	Remove and replace the I/DWR ring (52) from the sleeve (15).
12	 NOTICE! Before inserting the replacement I/DWR ring, clean the retaining slots with a cleaning solution.
13	Take out the diaphragm/plug unit (8, 11, 12, 25, 29, 31).
14	Unscrew and remove the nut (31).
15	Remove the diaphragm protection disc (12).
	Remove and replace the diaphragm (25).
16	 NOTICE! Before inserting the replacement diaphragm, clean the retaining slots with a cleaning solution.
17	Put the diaphragm protection disc (12) back in place.
18	Position and secure the nut (31).
	Remove the O-ring (44) from the plug (8) and replace it, lubricating it with synthetic grease.
19	 NOTICE! Before inserting the replacement O-ring, clean the retaining slots with a cleaning solution.
20	Unscrew and remove the gasket support (1).
	Remove the O-rings (41, 45) from the gasket support (1) and replace them, lubricating them with synthetic grease.
21	 NOTICE! Before inserting the replacement O-rings, clean the retaining slots with a cleaning solution.
22	Take out the plug guide (9).
23	Remove and replace the reinforced gasket (7) from the plug guide (9).



M/A accelerating valve

Step	Action
24	Remove the O-ring (43) from the plug guide (9) and replace it, lubricating it with synthetic grease. <div style="border: 1px solid black; padding: 2px;">  NOTICE! Before inserting the replacement O-ring, clean the retaining slots with a cleaning solution. </div>
25	Fit the plug guide (9) together with the reinforced gasket (7).
26	Place the gasket support (1) in the body (10).
27	Take out the diaphragm/plug unit (8, 11, 12, 25, 29, 31). <div style="border: 1px solid black; padding: 2px;">  NOTICE! Before inserting the diaphragm/plug unit, lubricate the plug (8) surface with silicone grease. </div>
28	Fit the sleeve (15) and the bracket (53).
29	Insert and fix the screws (33). <div style="border: 1px solid black; padding: 2px;">  NOTICE! Tighten the screws according to the cross diagram in paragraph 9.4.2.2. </div>
30	Position the upper spring support (14) together with the spring (22).
31	Fit the lower spring support (16) together with the ring (55).
32	Fit and secure the cap (17).
33	Remove and replace the O-ring (46) in the nut (27), lubricating it with synthetic grease. <div style="border: 1px solid black; padding: 2px;">  NOTICE! Before inserting the replacement O-ring, clean the retaining slots with a cleaning solution. </div>
34	Fit the adjusting screw (28) together with the nut (27).

Tab. 9.163.

 **WARNING!**

Ensure that all parts have been fitted correctly.

9.4.9 - SA SLAM-SHUT VALVE MAINTENANCE

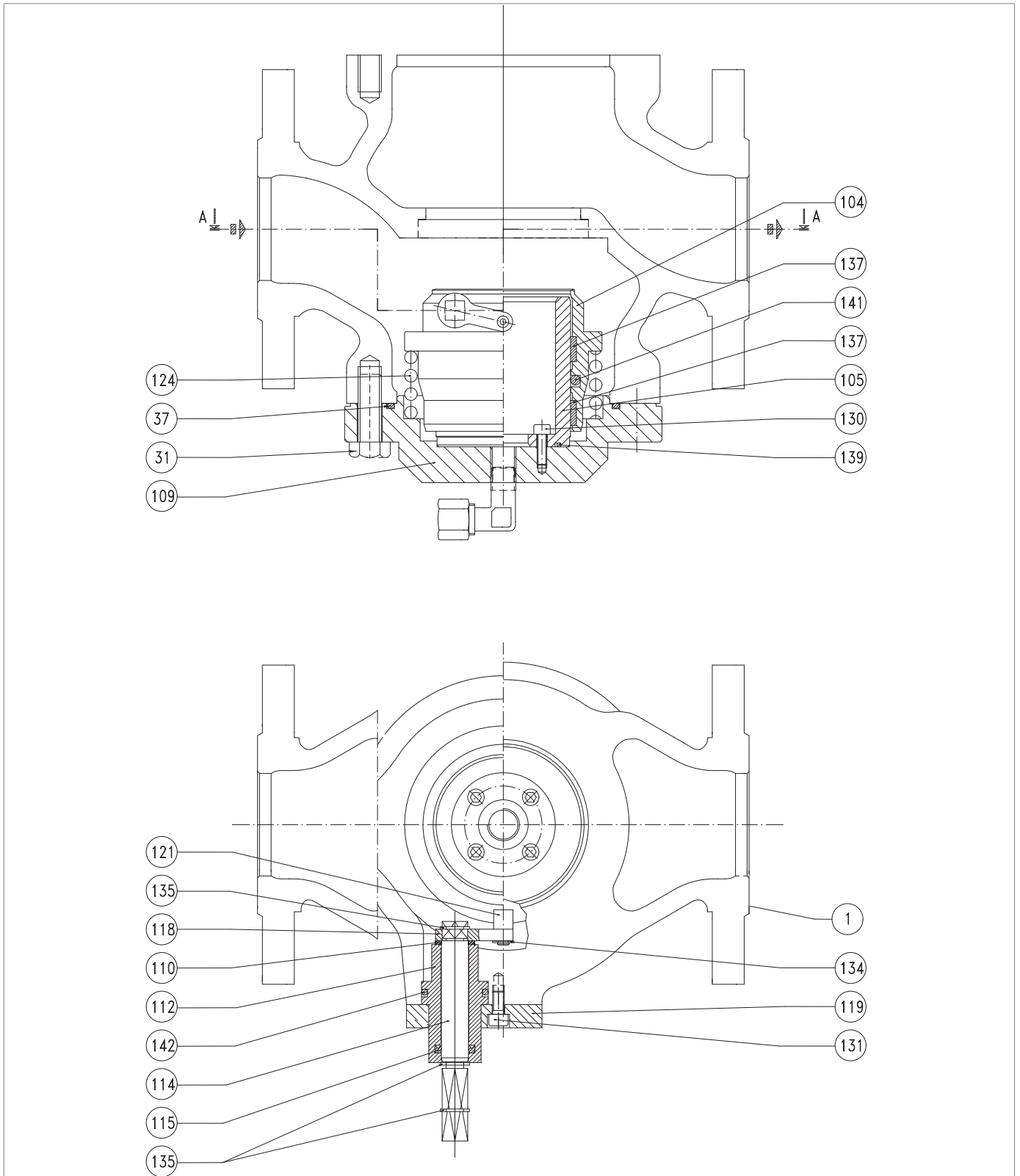





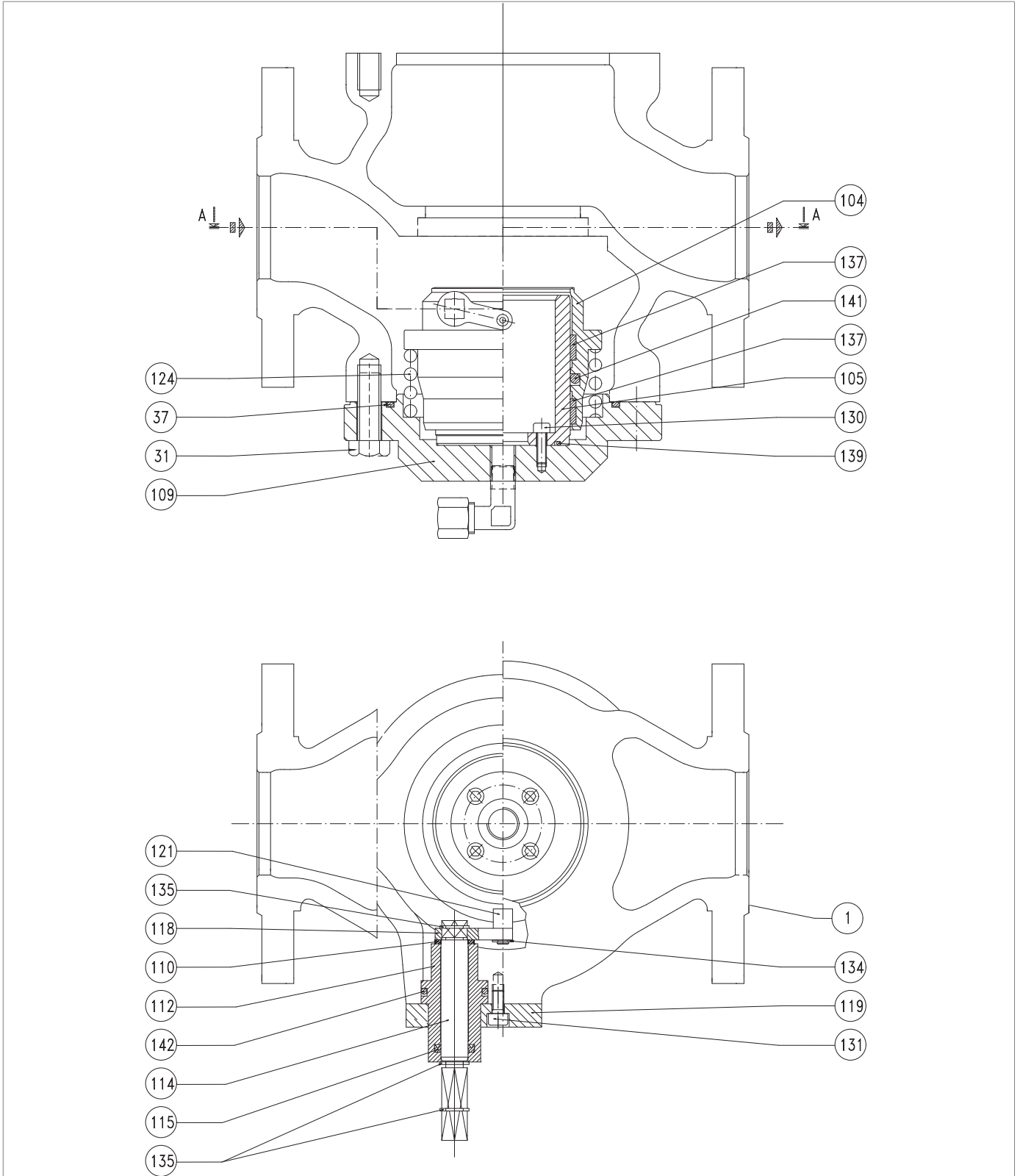



Fig. 9.87. Slam-shut valve SA

Step	Action
1	 WARNING! Check that the slam-shut valve is in the shut-off position.
2	Remove the Seeger ring (135).
3	Unscrew and remove the screws (131).
4	Remove the flange (119).
5	Pull the sleeve (112) out of the regulator body (1).
6	Remove the O-rings (115, 142) from the bush (112) and replace them, taking care to lubricate them with synthetic grease.  NOTICE! Before inserting the replacement O-rings, clean the retaining slots with a cleaning solution.
7	Insert the sleeve (112) into the regulator body (1).
8	Fit the flange (119).
9	Insert and fix the screws (131) according to the following tightening torque: <ul style="list-style-type: none"> • 1": Tab. 9.117 • 2": Tab. 9.118 • 2" ½: Tab. 9.119 • 3": Tab. 9.120 • 4": Tab. 9.121  NOTICE! Tighten the screws according to the cross diagram in paragraph 9.4.2.2.
10	Position the Seeger ring (135).
11	Unscrew and remove the screws (31) from the flange (109), taking care to support it.
12	Remove the flange (109) together with the spring (124) and plug (104) from the regulator body (1).
13	Remove the O-ring (37) from the flange (109) and replace it, taking care to lubricate it with synthetic grease.  NOTICE! Before inserting the replacement O-ring, clean the retaining slots with a cleaning solution.
14	Remove the plug (104) and place it on a shock-proof surface.
15	Remove the spring (124).
16	Remove the I/DWR rings (137) from the plug (104) and replace them; lubricate with synthetic grease.  NOTICE! Before inserting the replacement I/DWR rings, clean the retaining slots with a cleaning solution.
17	Remove the O-ring (141) from the plug (104) and replace it, taking care to lubricate it with synthetic grease.  NOTICE! Before inserting the replacement O-rings, clean the retaining slots with a cleaning solution.
18	Unscrew and remove the screws (130).
19	Remove the plug guide (105) from the flange (109).



Slam-shut valve SA

Step	Action
20	Remove the O-ring (139) from the plug guide (105) and replace it, lubricating it with synthetic grease. <div style="border: 1px solid black; padding: 2px;">  NOTICE! Before inserting the replacement O-rings, clean the retaining slots with a cleaning solution. </div>
21	Position the plug guide (105) in the flange (109).
22	Insert and fix the screws (130) according to the following tightening torque: <ul style="list-style-type: none"> • 1": Tab. 9.117 • 2": Tab. 9.118 • 2" ½: Tab. 9.119 • 3": Tab. 9.120 • 4": Tab. 9.121 <div style="border: 1px solid black; padding: 2px;">  NOTICE! Tighten the screws according to the cross diagram in paragraph 9.4.2.2. </div>
23	Insert the spring (124) into the plug (104).
24	Place the plug (104) into the flange (109).
25	Position the assembly (104, 109, 124) in the regulator body (1).
26	Insert and secure the screws (31) in the flange (109).

Tab. 9.164.

 **WARNING!**

Ensure that all parts have been fitted correctly.

9.4.10 - MAINTENANCE OF PRESSURE SWITCH MOD. SA

9.4.10.1 - PRESSURE SWITCH DISCONNECTION MOD. SA

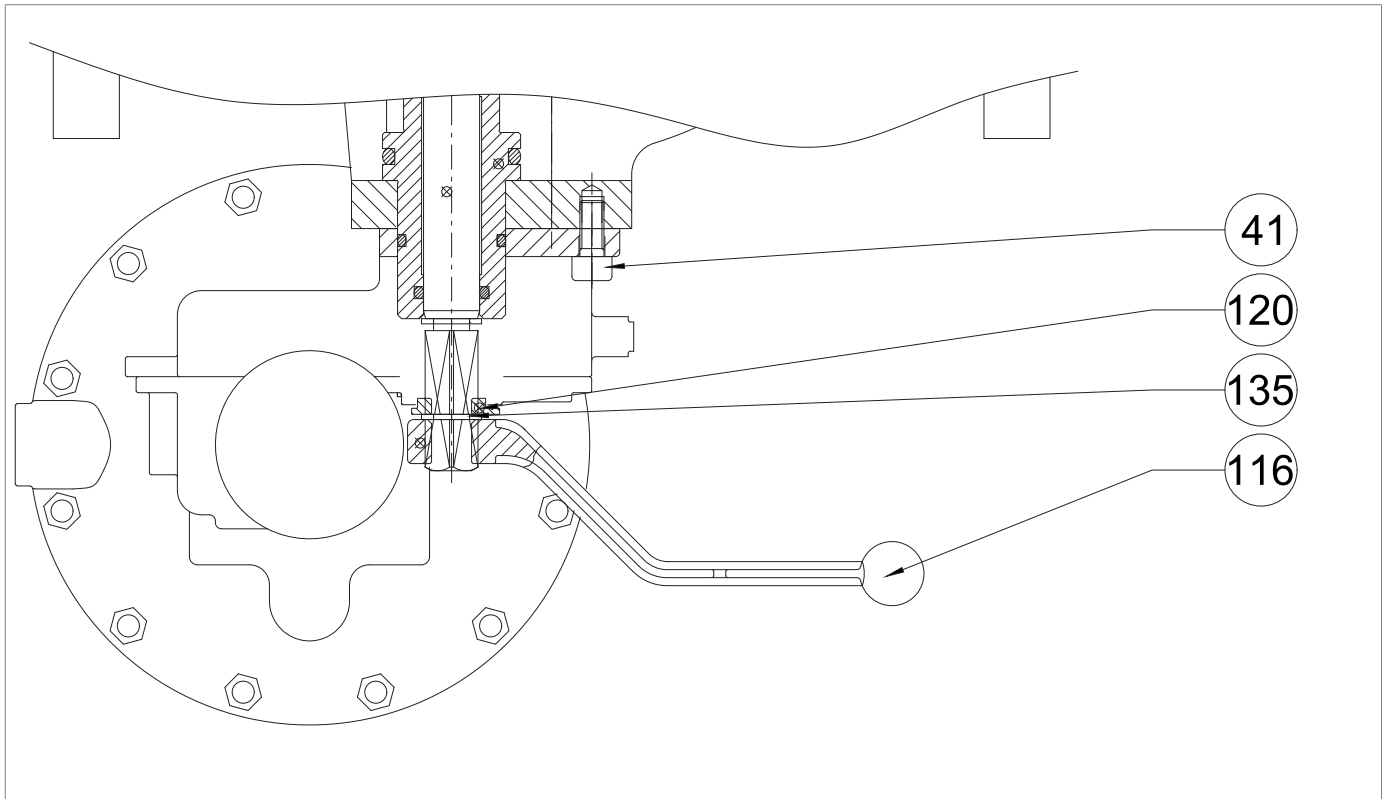

Fig. 9.88. Pressure switch mod. SA

To disconnect pressure switches mod. SN, proceed as in Tab. 9.165 (see Fig. 9.88):

Step	Action
1	Remove the lever (116).
2	Remove the Seeger ring (135).
3	Remove the position indicator (120).
4	Remove the screws (41).

Tab. 9.165.

9.4.10.2 - PRESSURE SWITCH SA-91, SA-92

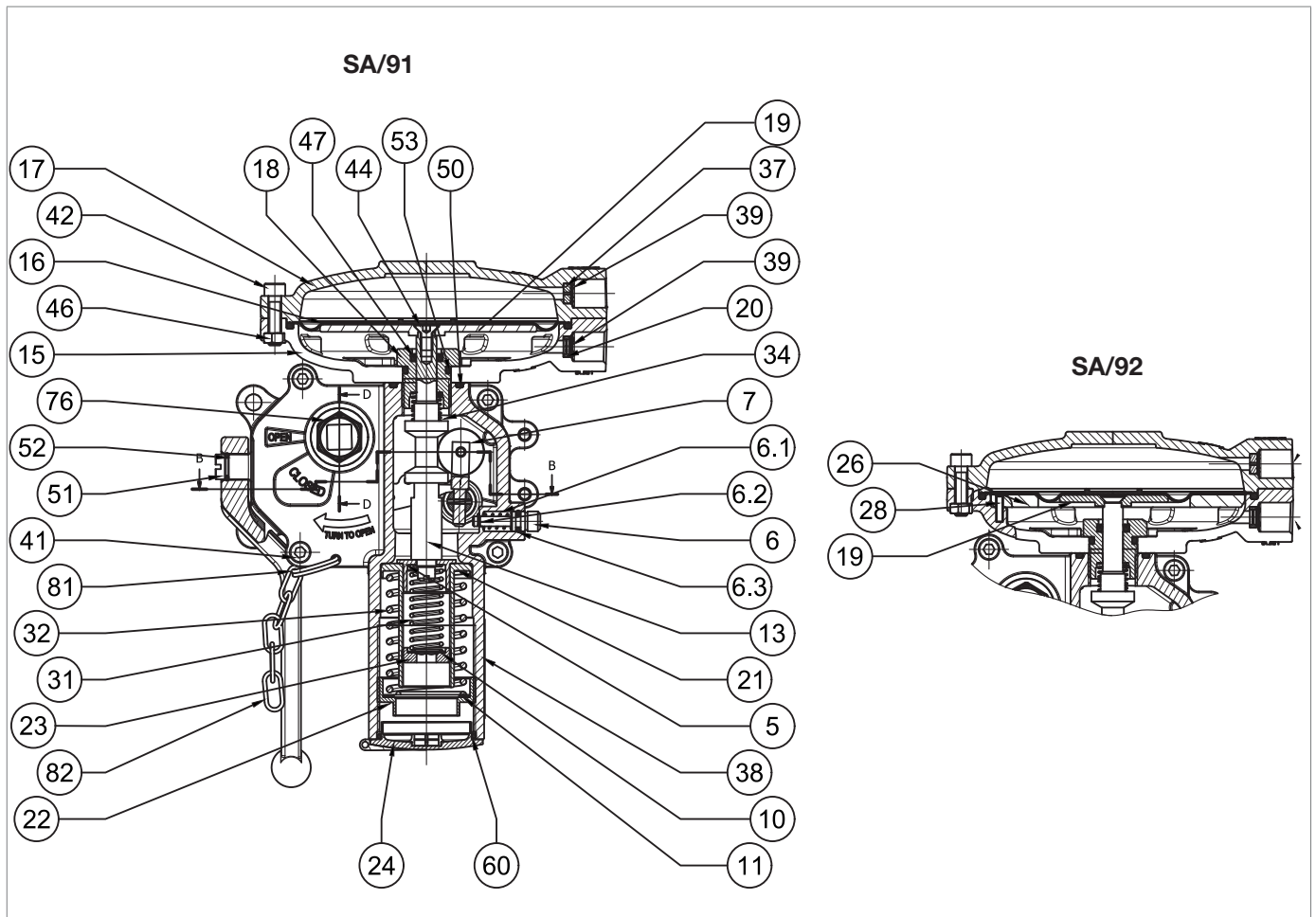





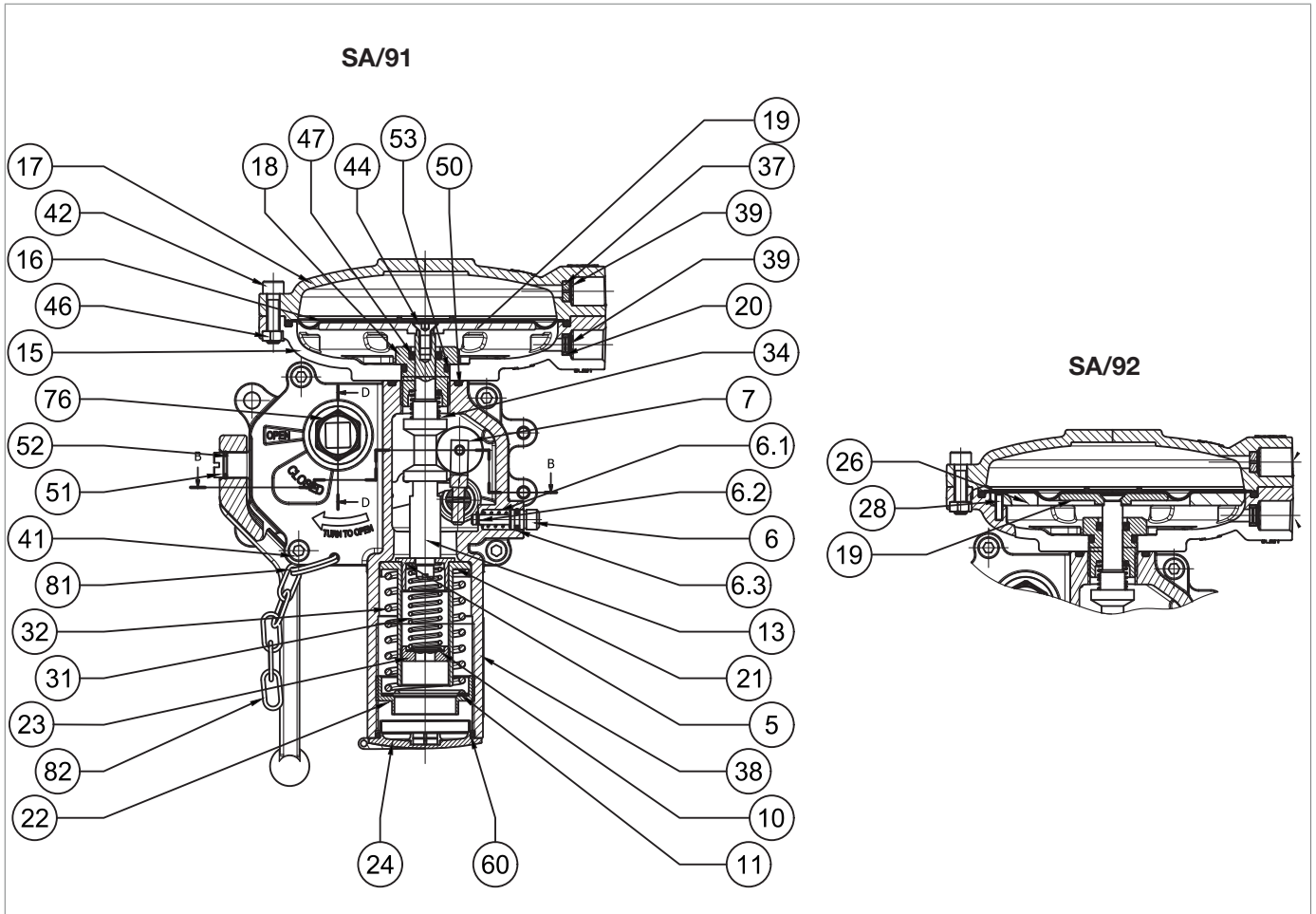



Fig. 9.89. Pressure switch SA-91, SA-92

Step	Action
1	Unscrew and remove the cap (24).
2	Remove the O-ring (60) from the cap (24) and replace it, lubricating it with synthetic grease. <div style="border: 1px solid black; padding: 5px;">  NOTICE! Before inserting the replacement O-ring, clean the retaining slots with a cleaning solution. </div>
3	Unscrew and remove the screws (42) together with the nuts (46).
4	Remove the cover (17).
5	Remove the diaphragm (16).
6	Unscrew the screw (44) while holding the diaphragm protection disc (19) in place.
7	Remove the diaphragm protection disc (19).
8	Unscrew and remove the slam-shut device guide (18).
9	Remove the flange (15).
10	Remove the O-ring (50) and replace it, lubricating it with synthetic grease. <div style="border: 1px solid black; padding: 5px;">  NOTICE! Before inserting the replacement O-rings, clean the retaining slots with a cleaning solution. </div>
11	Remove the O-ring (53) from the bush (18) and replace it, lubricating it with synthetic grease. <div style="border: 1px solid black; padding: 5px;">  NOTICE! Before inserting the replacement O-rings, clean the retaining slots with a cleaning solution. </div>
12	Remove the U-shaped ring (47) from the bush (18) and replace it, lubricating it with synthetic grease. <div style="border: 1px solid black; padding: 5px;">  NOTICE! Before inserting the replacement ring, clean the retaining slots with a cleaning solution. </div>
13	Fit the flange (15).
14	Insert and secure the slam-shut device guide (18) according to the tightening torque: <ul style="list-style-type: none"> • Pressure switch SA-91: Tab. 9.122 • Pressure switch SA-92: Tab. 9.123
15	Put the diaphragm protection disc (19) back in place
16	Insert and fasten the screw (44) while holding the diaphragm protection disc (19) in place, according to the tightening torque: <ul style="list-style-type: none"> • Pressure switch SA-91: Tab. 9.122 • Pressure switch SA-92: Tab. 9.123 <div style="border: 1px solid black; padding: 5px;">  NOTICE! Tighten the screws according to the cross diagram in paragraph 9.4.2.2. </div>
17	Position the diaphragm (16).
18	Fit the cover (17).



Pressure switch SA-91, SA-92

Step	Action
19	Insert and fasten the screws (42) together with the nuts (46), according to the tightening torque: <ul style="list-style-type: none"> • Pressure switch SA-91: Tab. 9.122 • Pressure switch SA-92: Tab. 9.123 <div style="border: 1px solid black; padding: 5px; margin-top: 10px;">  NOTICE! Tighten the screws according to the cross diagram in paragraph 9.4.2.2. </div>
20	Insert and fix the cap (24).

Tab. 9.166.

 **WARNING!**

Ensure that all parts have been fitted correctly.

9.4.10.3 - PRESSURE SWITCH SA-93

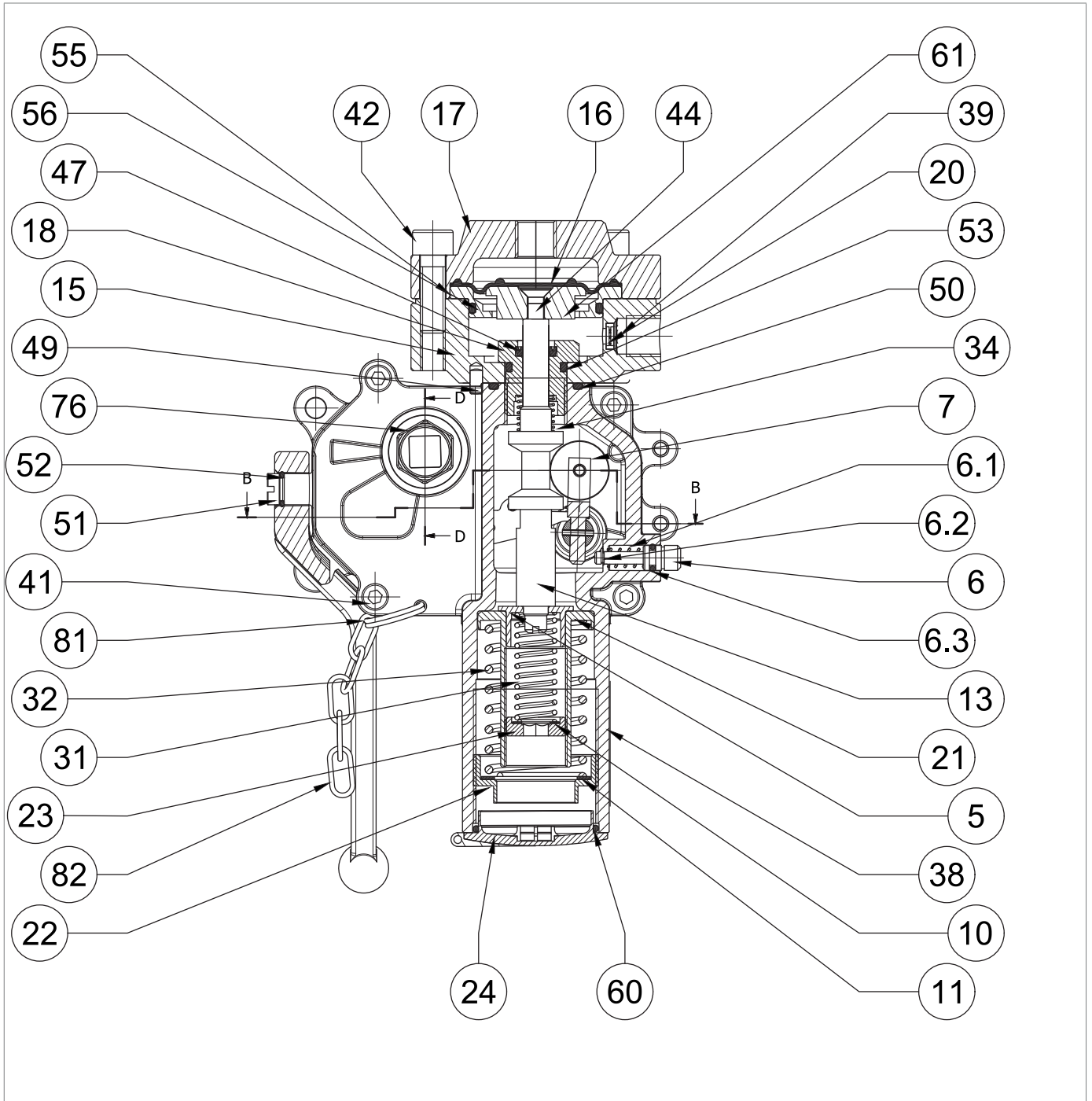
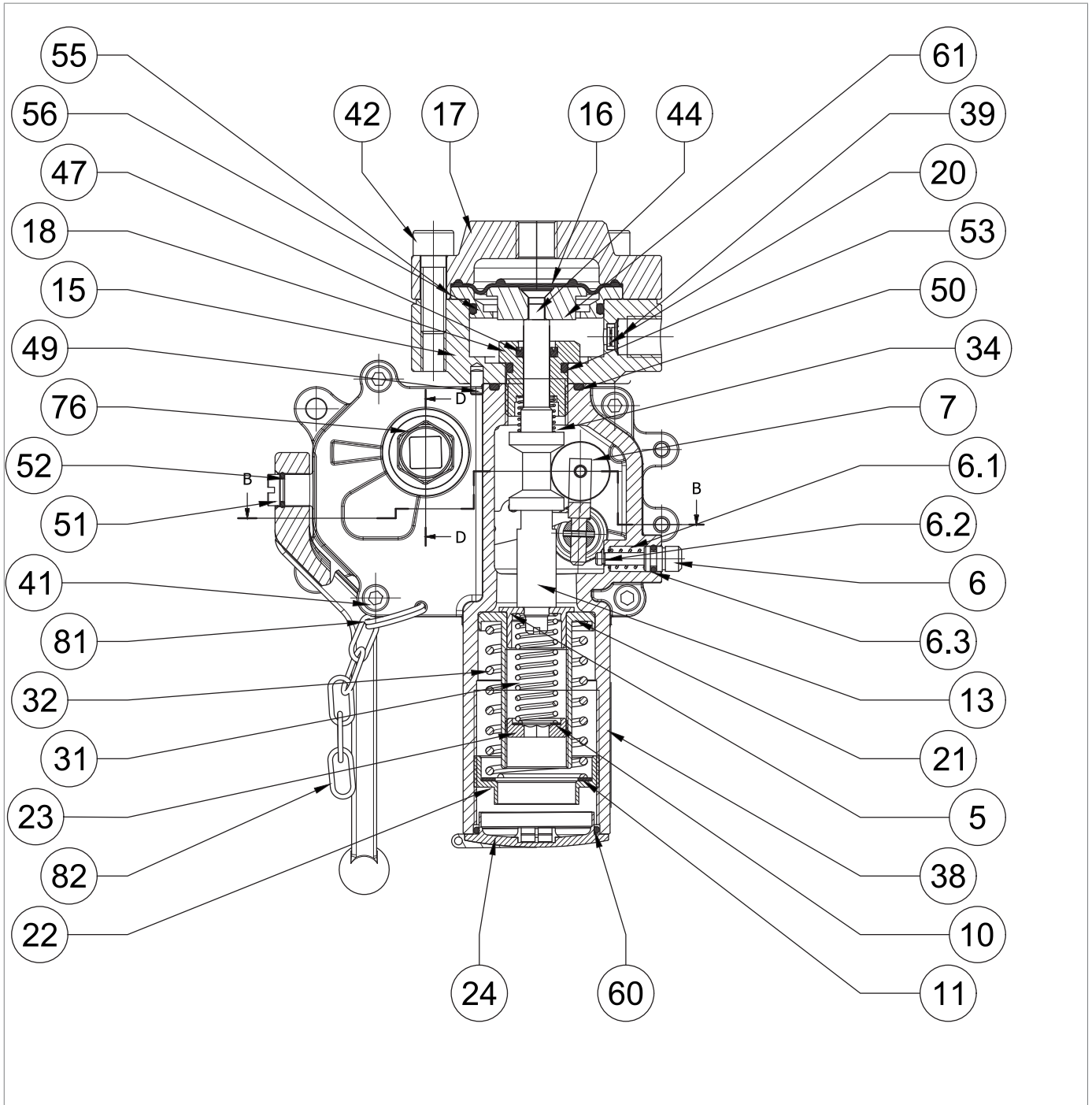



Fig. 9.90. Pressure switch SA-93

Step	Action
1	Unscrew and remove the cap (24).
2	Remove the O-ring (60) from the cap (24) and replace it, lubricating it with synthetic grease. ! NOTICE! Before inserting the replacement O-ring, clean the retaining slots with a cleaning solution.
3	Undo and remove the screws (42).
4	Remove the upper cover (17).
5	Remove the diaphragm (16).
6	Unscrew the screw (44), holding the diaphragm holder (61) in place.
7	Remove the diaphragm holder (61).
8	Remove the diaphragm protection disc (55) from the flange (15).
9	Remove and replace the O-ring (56) from the diaphragm protection disc (55), lubricating it with synthetic grease. ! NOTICE! Before inserting the replacement O-ring, clean the retaining slots with a cleaning solution.
10	Unscrew and remove the slam-shut device guide (18).
11	Remove the flange (15).
12	Remove the O-ring (50) and replace it, lubricating it with synthetic grease. ! NOTICE! Before inserting the replacement O-ring, clean the retaining slots with a cleaning solution.
13	Remove the O-ring (53) from the bush (18) and replace it, lubricating it with synthetic grease. ! NOTICE! Before inserting the replacement O-ring, clean the retaining slots with a cleaning solution.
14	Remove the U-shaped ring (47) from the bush (18) and replace it, lubricating it with synthetic grease. ! NOTICE! Before inserting the replacement O-rings, clean the retaining slots with a cleaning solution.
15	Fit the flange (15).
16	Insert and secure the slam-shut device guide (18) according to the tightening torque: <ul style="list-style-type: none"> • Pressure switch SA-93: Tab. 9.124
17	Insert the diaphragm protection disc (55) into the flange (15).
18	Position the diaphragm holder (61).
19	Insert and fasten the screw (44) while holding the diaphragm holder (61) in place, according to the tightening torque: <ul style="list-style-type: none"> • Pressure switch SA-93: Tab. 9.124 ! NOTICE! Tighten the screws according to the cross diagram in paragraph 9.4.2.2.



Pressure switch SA-93

Step	Action
20	Position the diaphragm (16).
21	Fit the cover (17)
22	Insert and fix the screws (42) according to the following tightening torque: <ul style="list-style-type: none"> • Pressure switch SA-93: Tab. 9.124 <div style="border: 1px solid blue; padding: 5px; margin-top: 5px;">  NOTICE! Tighten the screws according to the cross diagram in paragraph 9.4.2.2. </div>
23	Insert and fix the cap (24).

Tab. 9.167.

 **WARNING!**

Ensure that all parts have been fitted correctly.

9.4.10.4 - PRESSURE SWITCH RECONNECTION MOD. SA

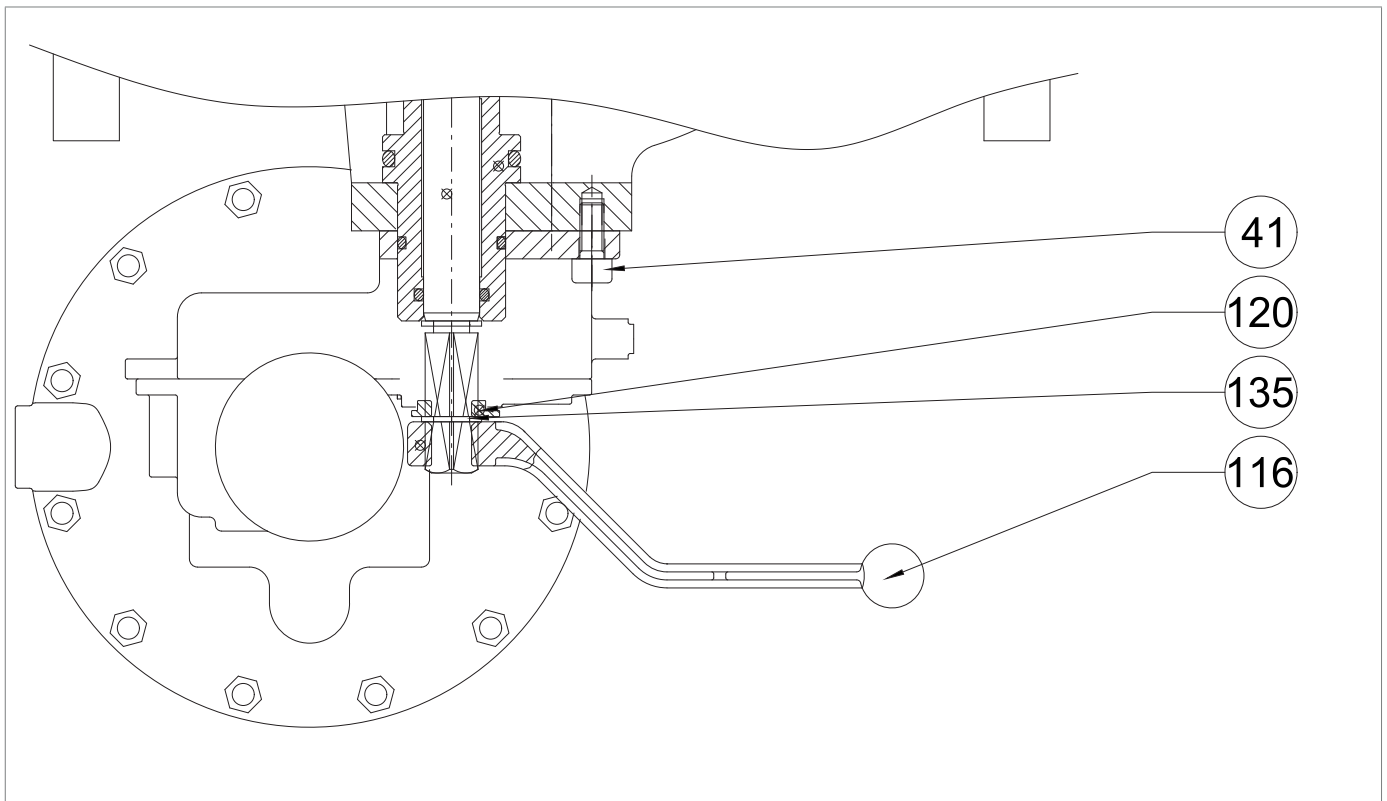

Fig. 9.91. Pressure switch mod. SA

To connect pressure switches mod. SN, proceed as in Tab. 9.168 (see Fig. 9.91):

Step	Action
1	Insert and fix the screws (41) according to the following tightening torques: <ul style="list-style-type: none"> • Pressure switch SA-91: Tab. 9.122 • Pressure switch SA-92: Tab. 9.123 • Pressure switch SA-93: Tab. 9.124
2	Position the position indicator (120).
3	Position the Seeger ring (135).
4	Fit the lever (116).

Tab. 9.168.

9.4.11 - MAINTENANCE BUILT-IN SLAM-SHUT VALVE SB/82

9.4.11.1 - SB/82 1" BUILT-IN SLAM-SHUT VALVE

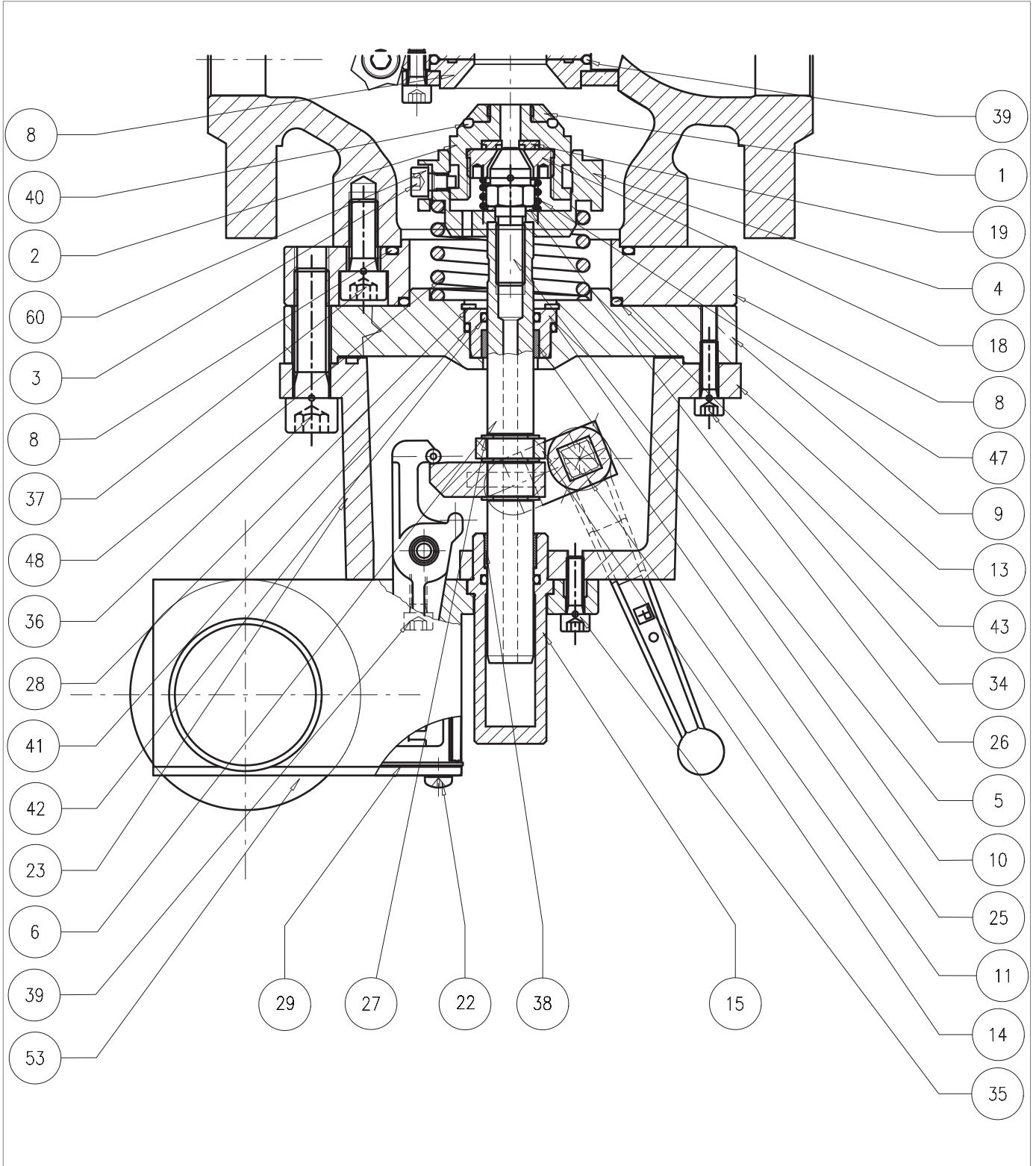







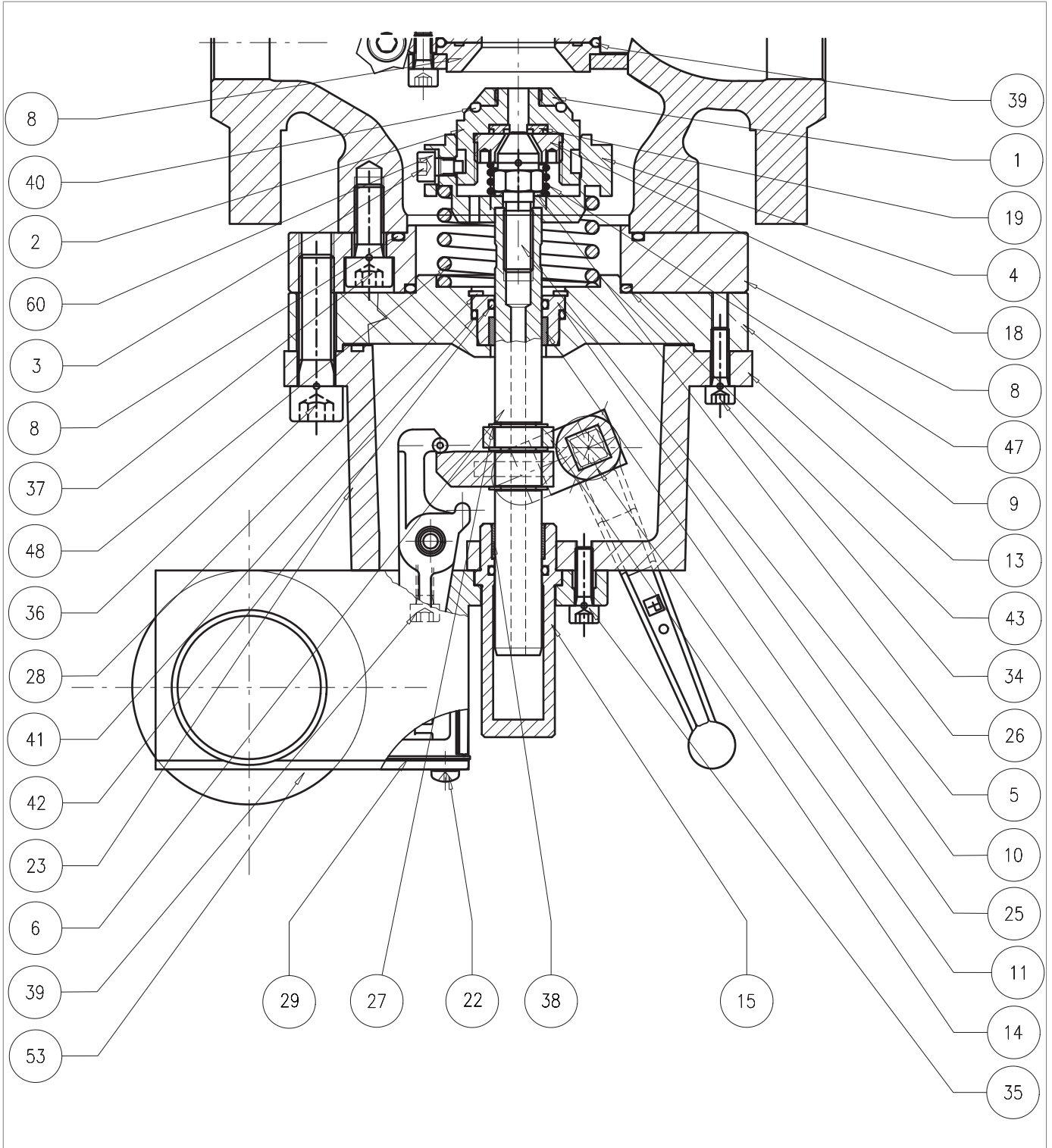

Fig. 9.92. SB/82 1" built-in slam-shut valve

Step	Action
1	 WARNING! In this step, support the built-in SB/82 slam-shut valve.
2	Unscrew the minimum spring (Fig. 8.34, ref. 17).  NOTICE! Check that the minimum spring is present.
3	Arm the slam-shut valve by moving the reset lever (16) to the 'OPEN' position.
4	 WARNING! Partially unscrew all screws before removing the first one to allow the spring to stretch.
5	Remove the SB/82 built-in slam-shut valve and place it on an impact-resistant surface.
6	Undo the screws (137).
7	Remove the flange (8).
8	Remove the O-ring (43) from the flange (8) and replace it, taking care to lubricate it with synthetic grease.  NOTICE! Before inserting the replacement O-ring, clean the retaining slots with a cleaning solution.
9	Remove the O-ring (37) from the flange (8) and replace it, taking care to lubricate it with synthetic grease.  NOTICE! Before inserting the replacement O-ring, clean the retaining slots with a cleaning solution.
10	Undo and remove the screws (3).
11	Remove the serrated washers (60).
12	Take out the plug unit.
13	Remove the spring (47).
14	Unscrew and remove the ring nut (18) with the appropriate tool.  NOTICE! Refer to table 7.59 of paragraph 7.1 "List of equipment".
15	Remove and replace the reinforced gasket (19).
16	Fit and fix the ring nut (18) with the appropriate tool.  NOTICE! Refer to table 7.59 of paragraph 7.1 "List of equipment".
17	Unscrew and remove the ring nut (1).
18	Remove the O-ring (40) from the plug (2) and replace it, taking care to lubricate it with synthetic grease.  NOTICE! Before inserting the replacement O-ring, clean the retaining slots with a cleaning solution.
19	Position and secure the ring nut (1).
20	Undo the plug screw (5).
21	Remove the washer (26).



SB/82 1" built-in slam-shut valve

Step	Action
22	Remove the spring (48) and the spring support (4).
23	Undo and remove the screws (22) of the pressure switch.
24	Remove the cover (119) together with the gasket (29).
25	Undo the side screws (39) inside the box.
24	Undo the screws (35).
25	Take out the pressure switch unit. ! NOTICE! For the maintenance procedure of the pressure switch assembly, please refer to par. 9.4.13.
26	Remove the cup (15).
27	Remove the O-ring (42) from the cup (15) and replace it, taking care to lubricate it with synthetic grease. ! NOTICE! Before inserting the replacement O-ring, clean the retaining slots with a cleaning solution.
28	Undo and remove the screws (34).
29	Remove the intermediate body (13) from the flange (9).
30	Extract the stem (6) taking care not to damage it.
31	Remove the Seeger ring (28) from the flange (9).
32	Remove the bush (10).
33	Remove the O-ring (41) from the bush (10) and replace it, lubricating it with synthetic grease. ! NOTICE! Before inserting the replacement O-ring, clean the retaining slots with a cleaning solution.
34	Remove the I/DWR ring (25) from the bush (10) and replace it, taking care to lubricate it with synthetic grease. ! NOTICE! Before inserting the replacement I/DWR ring, clean the retaining slots with a cleaning solution.
35	Fit the bush (10). ! NOTICE! Take care not to damage the O-ring (41).
36	Fit the Seeger ring (28).
37	Fit the stem (6). ! NOTICE! Lubricate the stem surface with silicone grease.
38	Fit the intermediate body (13).
39	Fit the cup (15).
40	Fit the pressure switch unit.
41	Insert and fix the screws (35) according to the following tightening torque: • 1": Tab. 9.125
42	Insert and fix the side screws (39) into the pressure switch according to the following tightening torque: • 1": Tab. 9.125
43	Fit the gasket (29) and the cover (119).

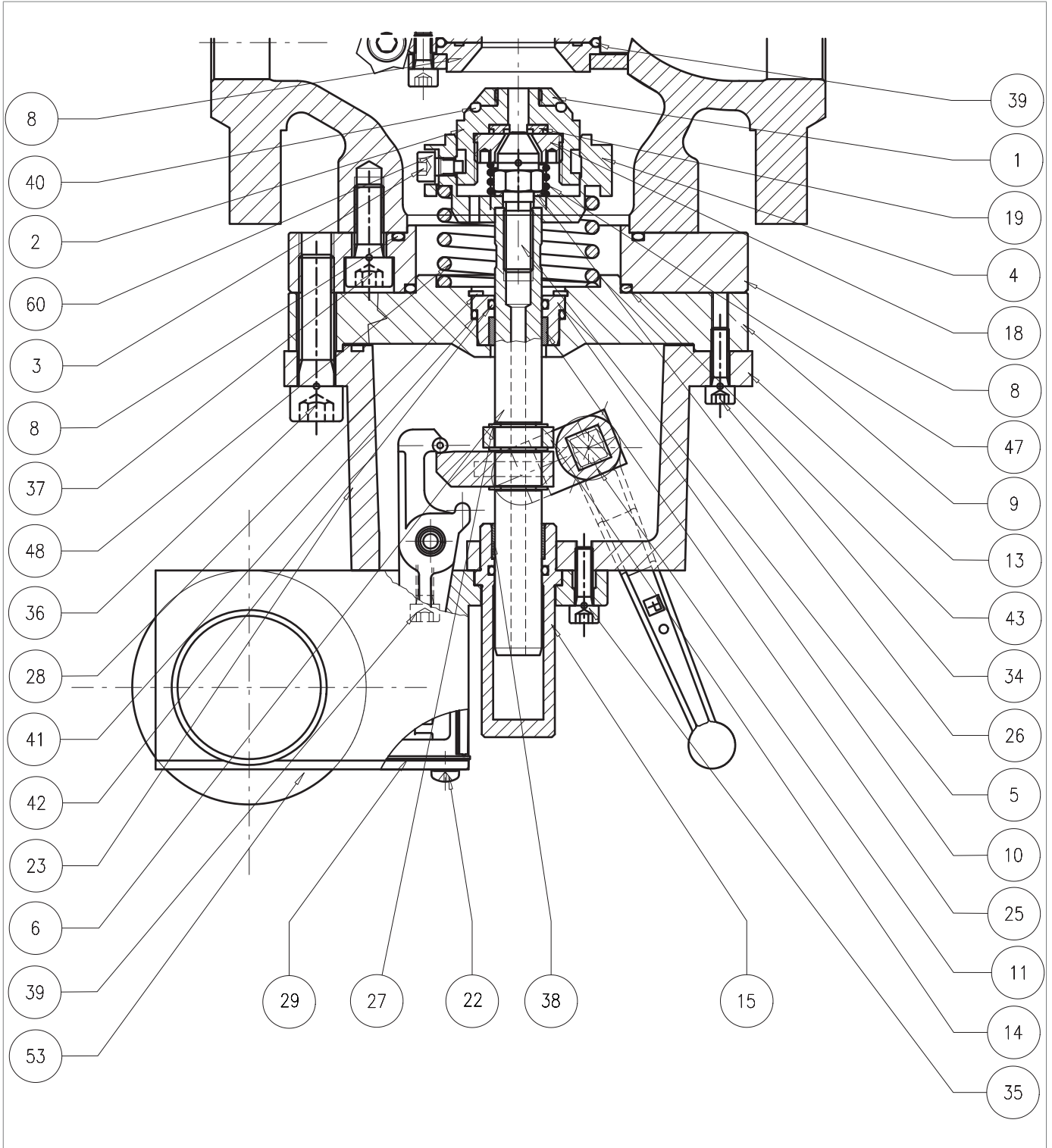

SB/82 1" built-in slam-shut valve

Step	Action
44	Insert and fix the screws (22).
45	Put the spring (48) and spring support (4) in place.
46	Fit the washer (26). NOTICE! Before inserting the screw (5), apply thread locking glue.
47	Fasten the plug screw (5) according to the tightening torque: • 1": Tab. 9.125
48	Fit the spring (47).
49	Fit the plug unit.
50	Insert the serrated washers (60). NOTICE! Before inserting the screw (3), apply thread locking glue.
51	Insert and fix the screws (3) according to the following tightening torque: • 1": Tab. 9.125 NOTICE! Tighten the screws according to the cross diagram in paragraph 9.4.2.2.
52	Fit the flange (8) on the body.
53	Fix the screws (137) according to the following tightening torque: • 1": Tab. 9.125 NOTICE! Tighten the screws according to the cross diagram in paragraph 9.4.2.2.
54	Turn the slam-shut valve upside down with the plug (2) facing downwards on an impact-resistant surface.
55	Arm the slam-shut valve by moving the reset lever (16) to the opening position
56	Put the SB/82 built-in slam-shut valve in place. NOTICE! Take care not to press the reset button (see fig. 4.12, ref. 10).
57	Insert and fix the screws (36) according to the following tightening torque: • 1": Tab. 9.125 NOTICE! Tighten the screws according to the cross diagram in paragraph 9.4.2.2.

Tab. 9.169.

WARNING!

Ensure that all parts have been fitted correctly.

9.4.11.2 - SB/82 2" SLAM SHUT VALVE ÷ 3"

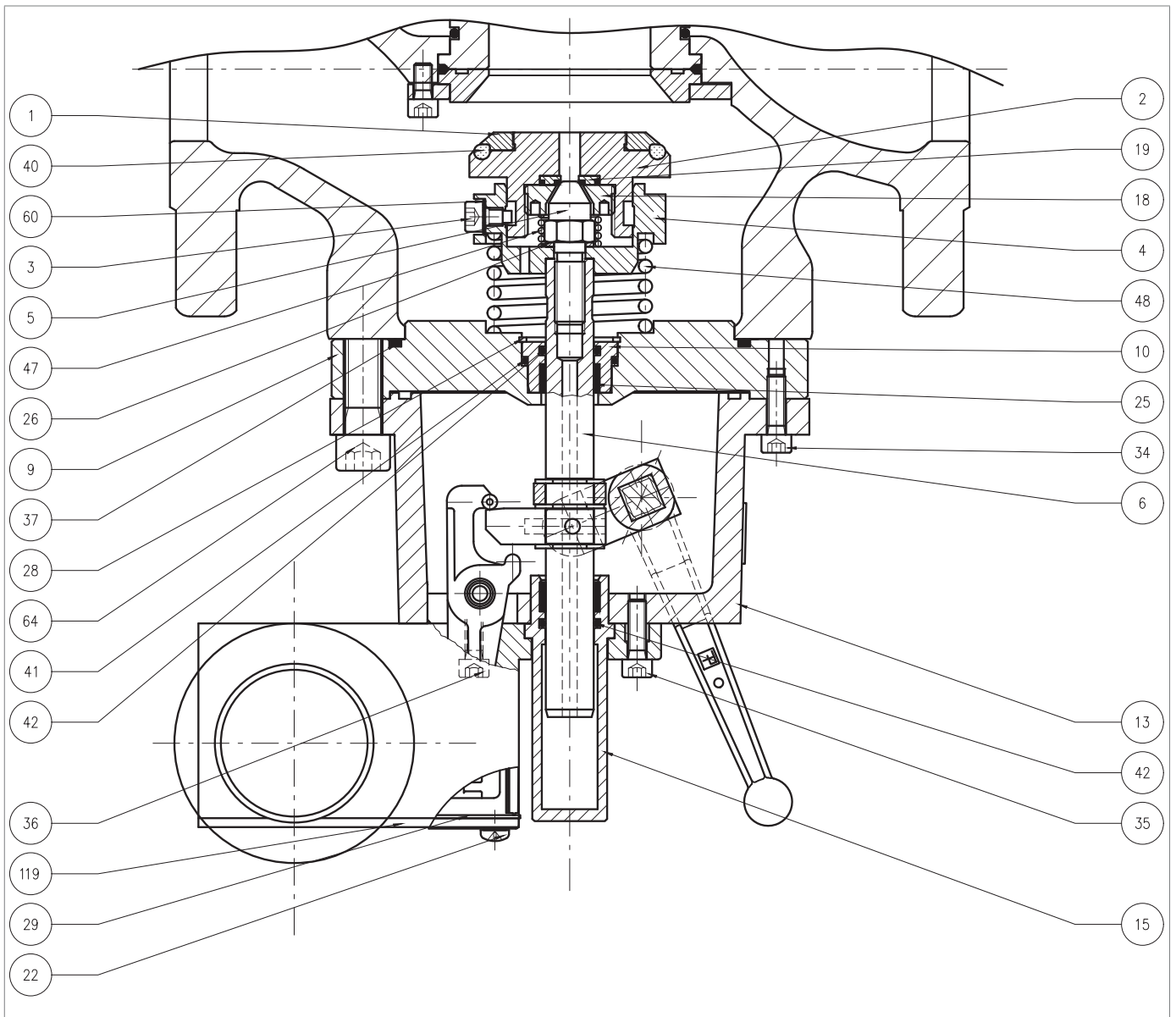



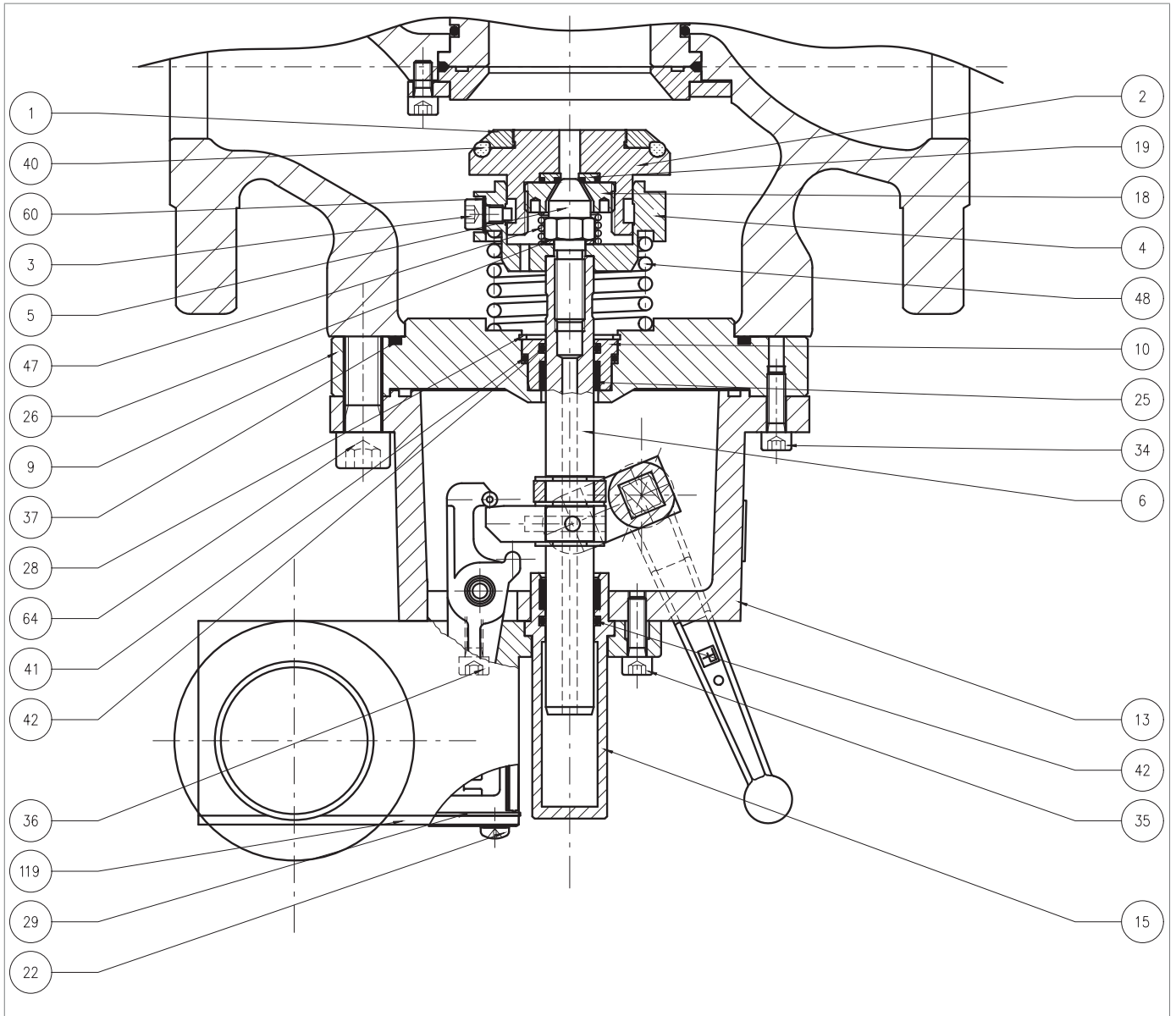

Fig. 9.93. Built-in slam-shut valve SB/82 2" ÷ 3"

Step	Action
1	 WARNING! Check that the slam-shut valve is in the shut-off position.
2	Unscrew the minimum spring (Fig. 8.34, ref. 17).  NOTICE! Check that the minimum spring is present.
3	Arm the slam-shut valve by moving the reset lever (16) to the opening position.
4	 WARNING! Partially unscrew all screws before removing the first one to allow the spring to stretch.
5	Remove the O-ring (37) from the flange (9) and replace it, taking care to lubricate it with synthetic grease.  NOTICE! Before inserting the replacement O-ring, clean the retaining slots with a cleaning solution.
6	Undo the screws (3) together with the toothed washers (60).
7	Take out the plug unit.
8	Remove the spring (47).
9	Unscrew and remove the ring nut (18) with the appropriate tool.  NOTICE! Please refer to the Tab. 7.62 of paragraph 7.1 “List of equipment”.
10	Remove and replace the reinforced gasket (19).
11	Fit and fix the ring nut (18) with the appropriate tool.  NOTICE! Please refer to the Tab. 7.62 of paragraph 7.1 “List of equipment”.
12	Unscrew and remove the ring nut (1).
13	Remove the O-ring (40) from the plug (2) and replace it, taking care to lubricate it with synthetic grease.  NOTICE! Before inserting the replacement O-ring, clean the retaining slots with a cleaning solution.
14	Position and secure the ring nut (1).
15	Undo the plug screw (5).
16	Remove the washer (26).
17	Remove the spring (48) and the spring support (4).
18	Undo and remove the screws (22) of the pressure switch.
19	Remove the cover (119) together with the gasket (29).
20	Undo the side screws (36) inside the control pressure switch.
21	Undo the external screws (35).





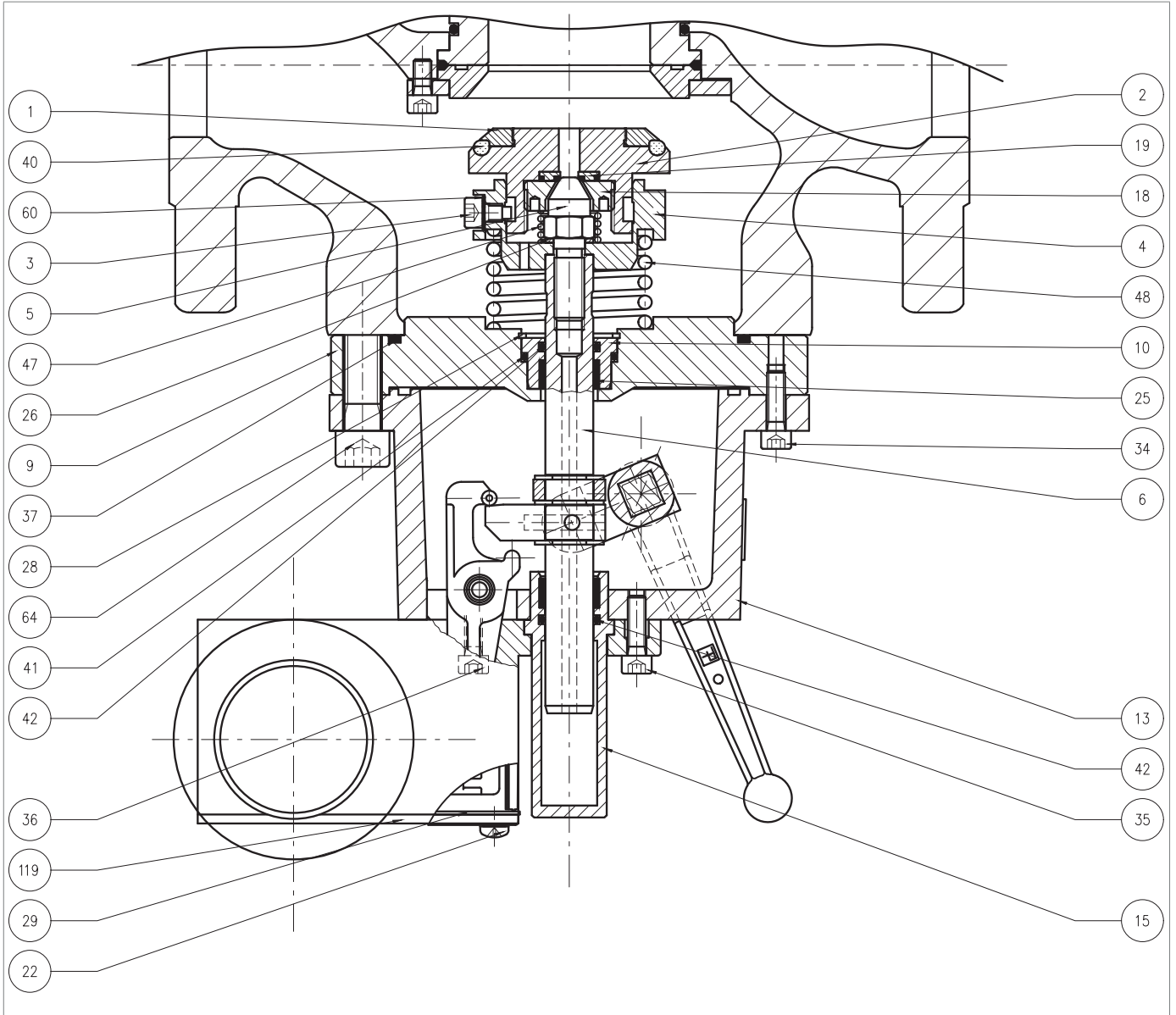

Built-in slam-shut valve SB/82 2" ÷ 3"

Step	Action
22	Take out the pressure switch unit. NOTICE! For the maintenance procedure of the pressure switch assembly, please refer to par. 9.4.13.
23	Remove the cup (15).
24	Remove the O-ring (42) from the cup (15) and replace it, taking care to lubricate it with synthetic grease. NOTICE! Before inserting the replacement O-ring, clean the retaining slots with a cleaning solution.
25	Undo and remove the screws (34).
26	Remove the intermediate body (13)
27	Extract the stem (6) taking care not to damage it.
28	Remove the Seeger ring (28) from the flange (9).
29	Remove the bush (10).
30	Remove the O-ring (41) from the flange (9) and replace it, taking care to lubricate it with synthetic grease. NOTICE! Before inserting the replacement O-ring, clean the retaining slots with a cleaning solution.
31	Remove the O-ring (42) from the bush (10) and replace it, lubricating it with synthetic grease. NOTICE! Before inserting the replacement O-ring, clean the retaining slots with a cleaning solution.
32	Remove the I/DWR ring (25) from the bush (10) and replace it, taking care to lubricate it with synthetic grease. NOTICE! Before fitting the replacement I/DWR ring, clean the retaining slots using a cleaning solution.
33	Fit the valve seat (10), taking care not to damage the O-ring (41).
34	Place the Seeger ring (28) in the flange (9).
35	Place the stem (6) in the bush (10). NOTICE! Lubricate the stem surface with silicone grease.
36	Fit the intermediate body (13).
37	Insert and fix the screws (34).
38	Fit the cup (15).
39	Fit the pressure switch unit.
40	Insert and fix the screws (35) according to the following tightening torque: <ul style="list-style-type: none"> • 2": Tab. 9.126 • 2" ½: Tab. 9.127 • 3": Tab. 9.128 NOTICE! Tighten the screws according to the cross diagram in paragraph 9.4.2.2.



Built-in slam-shut valve SB/82 2" ÷ 3"

Step	Action
41	Insert and fix the side screws (36) according to the following tightening torque: <ul style="list-style-type: none"> • 2": Tab. 9.126 • 2" ½: Tab. 9.127 • 3": Tab. 9.128 <div style="border: 1px solid black; padding: 5px;">  NOTICE! Tighten the screws according to the cross diagram in paragraph 9.4.2.2. </div>
42	Fit the gasket (29) together with the cover (119).
43	Insert and fix the screws (22).
44	Put the spring (48) and spring support (4) in place.
45	Fit the washer (26).
46	Insert and fix the plug screws (5) according to the following tightening torque: <ul style="list-style-type: none"> • 2": Tab. 9.126 • 2" ½: Tab. 9.127 • 3": Tab. 9.128 <div style="border: 1px solid black; padding: 5px;">  NOTICE! <ul style="list-style-type: none"> • Before inserting the screw (5), apply thread locking glue; • Tighten the screws according to the cross diagram in paragraph 9.4.2.2 </div>
47	Fit the spring (47).
48	Fit the plug unit.
49	Insert the screws (3) together with the toothed washers (60). <div style="border: 1px solid black; padding: 5px;">  NOTICE! Before inserting the screw (3), apply thread locking glue. </div>
50	Fasten the screws (3), holding down the plug unit to compress the spring (47) in the plug guide (4).
51	Turn the slam-shut valve upside down with the plug (2) facing downwards on an impact-resistant surface.
52	Arm the slam-shut valve by moving the reset lever (16) to the opening position
53	Position the slam-shut valve. <div style="border: 1px solid black; padding: 5px;">  NOTICE! Take care not to press the reset button (see fig. 4.12, ref. 10). </div>
54	Insert and fix the screws (64) according to the following tightening torque: <ul style="list-style-type: none"> • 2": Tab. 9.126 • 2" ½: Tab. 9.127 • 3": Tab. 9.128 <div style="border: 1px solid black; padding: 5px;">  NOTICE! Tighten the screws according to the cross diagram in paragraph 9.4.2.2. </div>

Tab. 9.170.

 **WARNING!**

Ensure that all parts have been fitted correctly.

9.4.11.3 - BUILT-IN SLAM SHUT VALVE SB/82 4" ÷ 8"

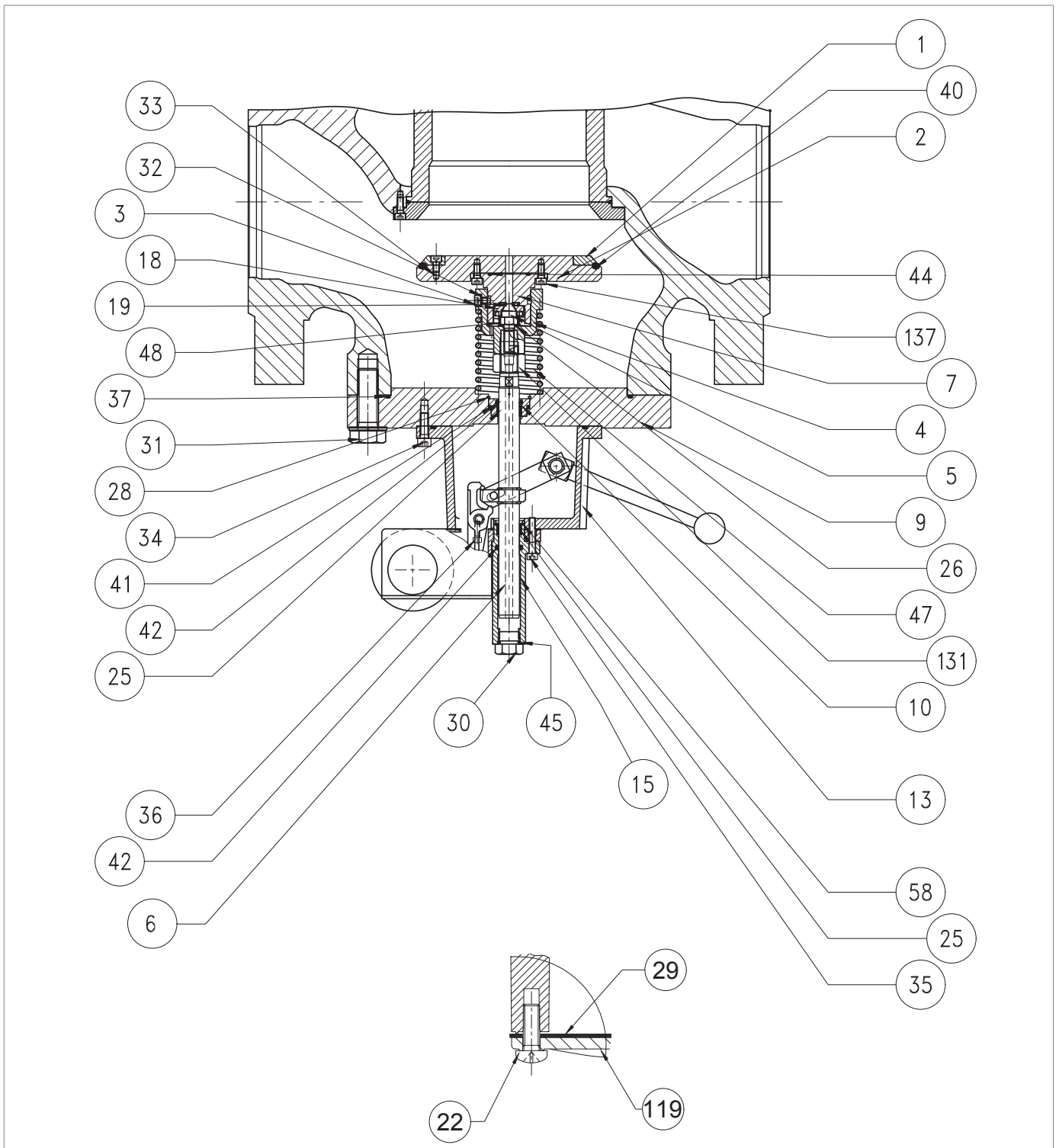







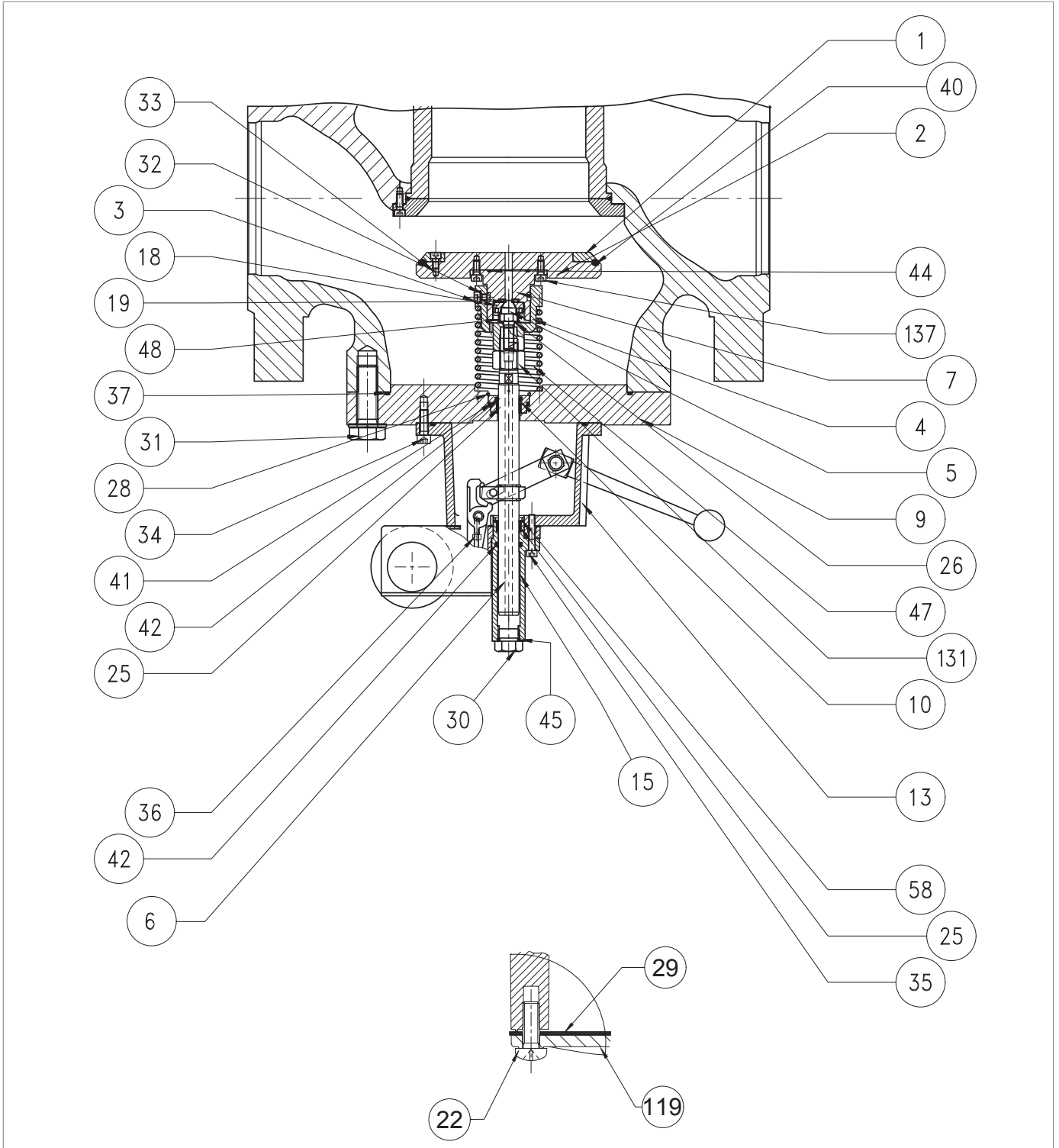







Fig. 9.94. Built-in slam-shut valve SB/82 4" ÷ 8"

Step	Action
1	 WARNING! Check that the slam-shut valve is in the shut-off position.
2	Unscrew the minimum spring (Fig. 8.34, ref. 17).  NOTICE! Check that the minimum spring is present.
3	Arm the slam-shut valve by moving the reset lever (16) to the 'OPEN' position.
4	Undo and remove the screws (31).
5	Remove the O-ring (37) from the flange (9) and replace it, taking care to lubricate it with synthetic grease.  NOTICE! Before inserting the replacement O-ring, clean the retaining slots with a cleaning solution.
6	Undo the screws (3) together with the toothed washers (32).
7	Take out the plug unit.
8	Remove the spring (47).
9	Unscrew and remove the ring nut (18) with an appropriate tool.  NOTICE! Please refer to the Tab. 7.62 of paragraph 7.1 "List of equipment".
10	Remove and replace the reinforced gasket (19).
11	Fit and fix the ring nut (18) with the appropriate tool.
12	Undo and remove the screws (137).
13	Remove the O-ring (44) from the plug support (7) and replace it, taking care to lubricate it with synthetic grease.  NOTICE! Before inserting the replacement O-ring, clean the retaining slots with a cleaning solution.
14	Undo the screws (33).
15	Remove the ring nut (1).
16	Remove the O-ring (40) from the plug (2) and replace it, taking care to lubricate it with synthetic grease.  NOTICE! Before inserting the replacement O-ring, clean the retaining slots with a cleaning solution.
17	Fit the ring nut (1).
18	Insert and fix the screws (33) according to the following tightening torques: <ul style="list-style-type: none"> • 4": Tab. 9.129 • 6": Tab. 9.130 • 8": Tab. 9.131  NOTICE! Tighten the screws according to the cross diagram in paragraph 9.4.2.2.
19	Place the plug (2) on the plug support (7).



Built-in slam-shut valve SB/82 4" ÷ 8"

Step	Action
20	Insert and fix the screws (137) according to the following tightening torques: <ul style="list-style-type: none"> • 4": Tab. 9.129 • 6": Tab. 9.130 • 8": Tab. 9.131 <div style="border: 1px solid black; padding: 5px; margin-top: 10px;">  NOTICE! Tighten the screws according to the cross diagram in paragraph 9.4.2.2. </div>
21	Undo the plug screw (5).
22	Remove the washer (26).
23	Remove the spring (48) and the spring support (4).
24	Unscrew and remove the nut (131).
25	Undo and remove the screws (22) of the pressure switch.
26	Remove the cover (119) and the gasket (29).
27	Undo the side screws (36) inside the control pressure switch.
28	Undo the screws (35).
29	Remove the cup (15).
30	Remove the O-ring (42) from the cup (15) and replace it, taking care to lubricate it with synthetic grease. <div style="border: 1px solid black; padding: 5px; margin-top: 10px;">  NOTICE! Before inserting the replacement O-ring, clean the retaining slots with a cleaning solution. </div>
31	Remove the cap (30).
32	VALID ONLY FOR 6"-8" Remove the O-ring (45) from the cap (30) and replace it, taking care to lubricate it with synthetic grease. <div style="border: 1px solid black; padding: 5px; margin-top: 10px;">  NOTICE! Before inserting the replacement O-ring, clean the retaining slots with a cleaning solution. </div>
33	Remove the Seeger ring (58) from the cup (15).
34	Remove the I/DWR ring (25) from the cup (15) and replace it, taking care to lubricate it with synthetic grease. <div style="border: 1px solid black; padding: 5px; margin-top: 10px;">  NOTICE! Before fitting the replacement I/DWR ring, clean the retaining slots using a cleaning solution. </div>
35	Place the Seeger ring (58) in the cup (15).
36	Take out the pressure switch unit. <div style="border: 1px solid black; padding: 5px; margin-top: 10px;">  NOTICE! For the maintenance procedure of the pressure switch assembly, please refer to par. 9.4.13. </div>
37	Undo and remove the screws (34).
38	Remove the intermediate body (13).
39	Remove the Seeger ring (28) from the flange (9).
40	Remove the bush (10).

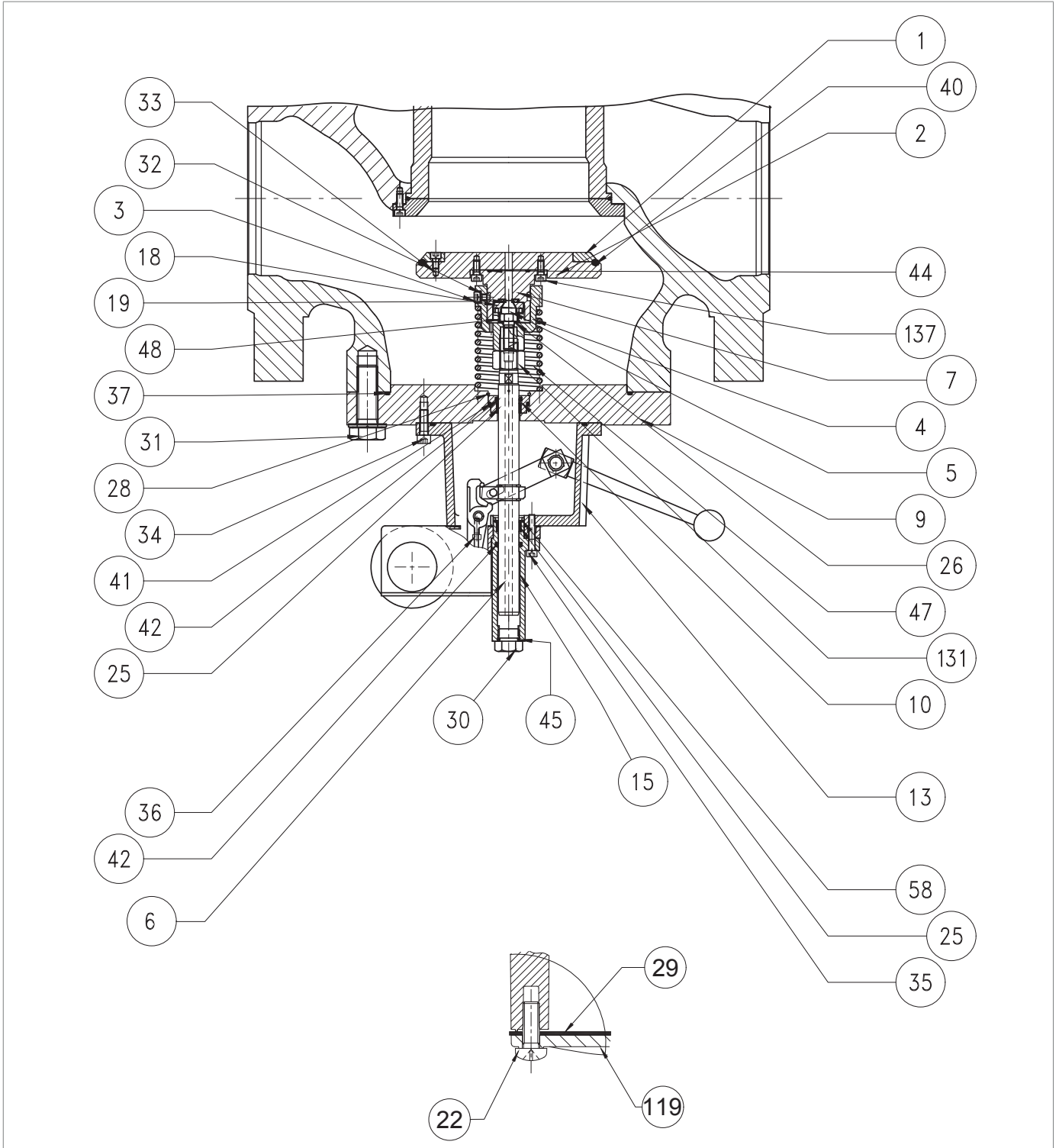



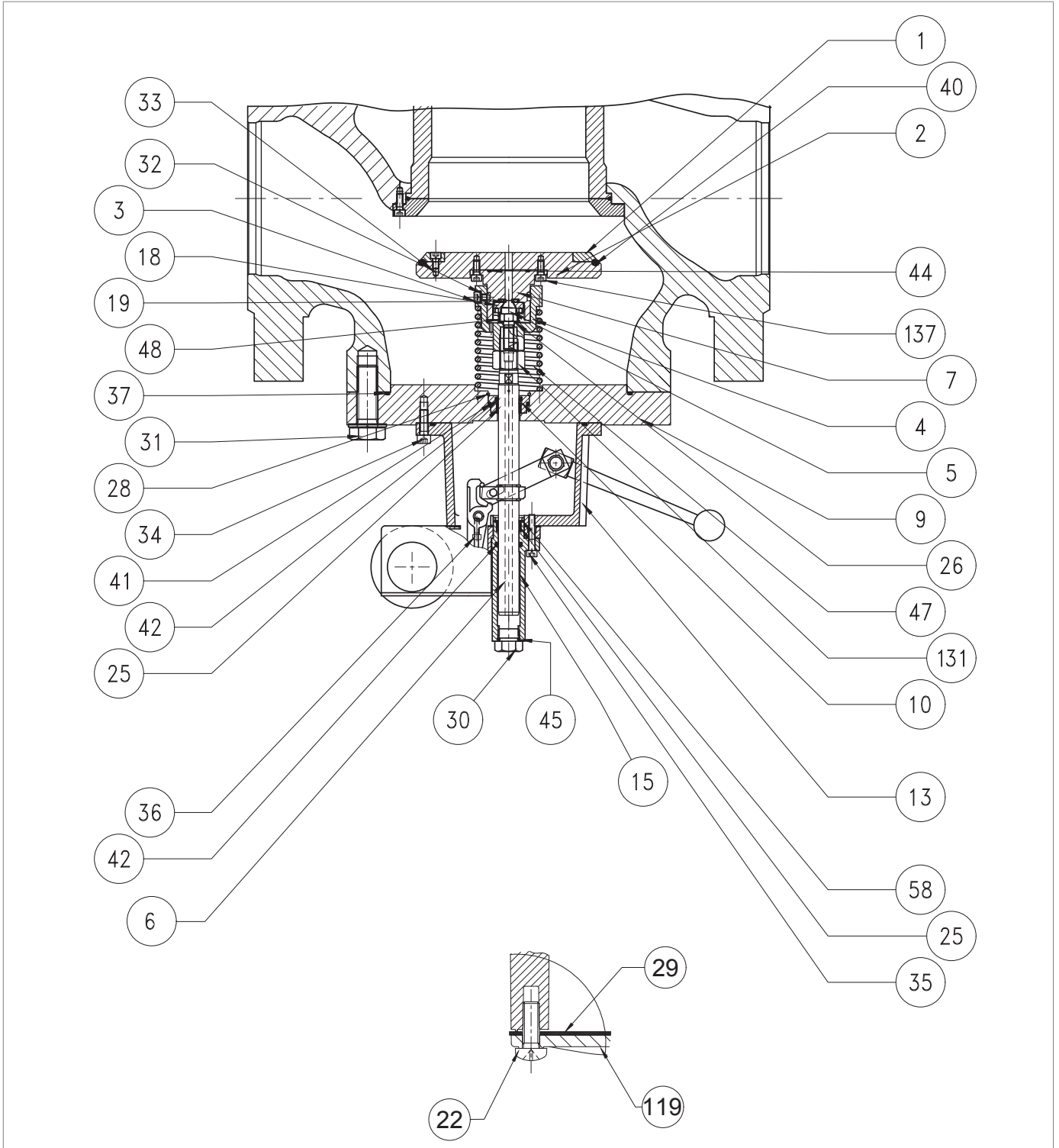

Built-in slam-shut valve SB/82 4" ÷ 8"

Step	Action
41	<p>Remove the O-ring (41) from the flange (9) and replace it, taking care to lubricate it with synthetic grease.</p> <p>NOTICE! Before inserting the replacement O-ring, clean the retaining slots with a cleaning solution.</p>
42	<p>Remove the O-ring (42) from the bush (10) and replace it, lubricating it with synthetic grease.</p> <p>NOTICE! Before inserting the replacement O-ring, clean the retaining slots with a cleaning solution.</p>
43	<p>Remove the I/DWR ring (25) from the bush (10) and replace it, taking care to lubricate it with synthetic grease.</p> <p>NOTICE! Before fitting the replacement I/DWR ring, clean the retaining slots using a cleaning solution.</p>
44	Fit the valve seat (10), taking care not to damage the O-ring (41).
45	Place the Seeger ring (28) in the flange (9).
46	<p>Place the stem (6) in the bush (10).</p> <p>NOTICE! Lubricate the stem surface with silicone grease.</p>
47	Fit the intermediate body (13).
48	<p>Insert and fix the screws (34) according to the following tightening torques:</p> <ul style="list-style-type: none"> 4": Tab. 9.129 6": Tab. 9.130 8": Tab. 9.131 <p>NOTICE! Tighten the screws according to the cross diagram in paragraph 9.4.2.2.</p>
49	Fit the pressure switch unit.
50	Fit the cup (15).
51	<p>Insert and fix the screws (35) according to the following tightening torques:</p> <ul style="list-style-type: none"> 4": Tab. 9.129 6": Tab. 9.130 8": Tab. 9.131 <p>NOTICE! Tighten the screws according to the cross diagram in paragraph 9.4.2.2.</p>
52	<p>Insert and fix the side screws (36) into the pressure switch according to the following tightening torques:</p> <ul style="list-style-type: none"> 4": Tab. 9.129 6": Tab. 9.130 8": Tab. 9.131 <p>NOTICE! Tighten the screws according to the cross diagram in paragraph 9.4.2.2.</p>
53	Fit and fix the cap (30).
54	Fit the gasket (29) and the cover (119).



Built-in slam-shut valve SB/82 4" ÷ 8"

Step	Action
55	Insert and fix the screws (22).  NOTICE! Tighten the screws according to the cross diagram in paragraph 9.4.2.2.
56	Insert and fix the screws (131).
57	Put the spring (48) and spring support (4) in place.
58	Fit the washer (26).
59	Insert and secure the plug screw (5), applying threadlocking glue, according to the tightening torques: <ul style="list-style-type: none"> • 4": Tab. 9.129 • 6": Tab. 9.130 • 8": Tab. 9.131  NOTICE! Tighten the screws according to the cross diagram in paragraph 9.4.2.2.
60	Fit the spring (47).
61	Fit the plug unit.
62	Insert the screws (3) together with the toothed washers (60).  NOTICE! Before inserting the screw (3), apply thread locking glue.
63	Fasten the screws (3), holding down the plug unit to compress the spring (47) in the plug guide (4).
64	Turn the slam-shut valve upside down with the plug (2) facing downwards on an impact-resistant surface.
65	Arm the slam-shut valve by moving the reset lever (16) to the opening position
66	Position the slam-shut valve.  NOTICE! Take care not to press the reset button (see fig. 4.10, ref. 10).
67	Position the slam-shut valve.  NOTICE! Take care not to press the reset button (see fig. 4.10, ref. 10).

Tab. 9.171.

 **WARNING!**
 Ensure that all parts have been fitted correctly.

9.4.11.4 - BUILT-IN SLAM-SHUT VALVE SB/82 10"

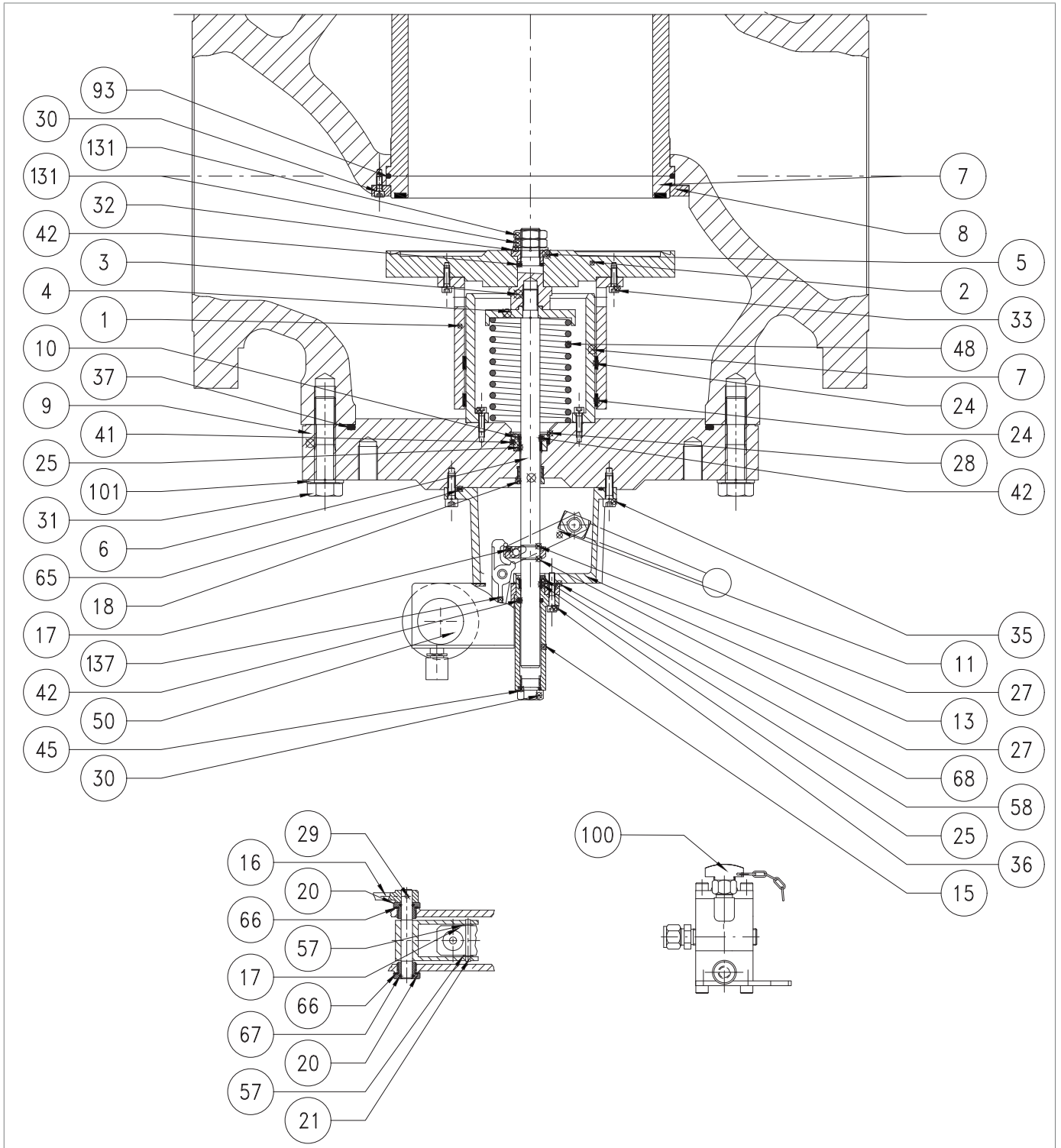





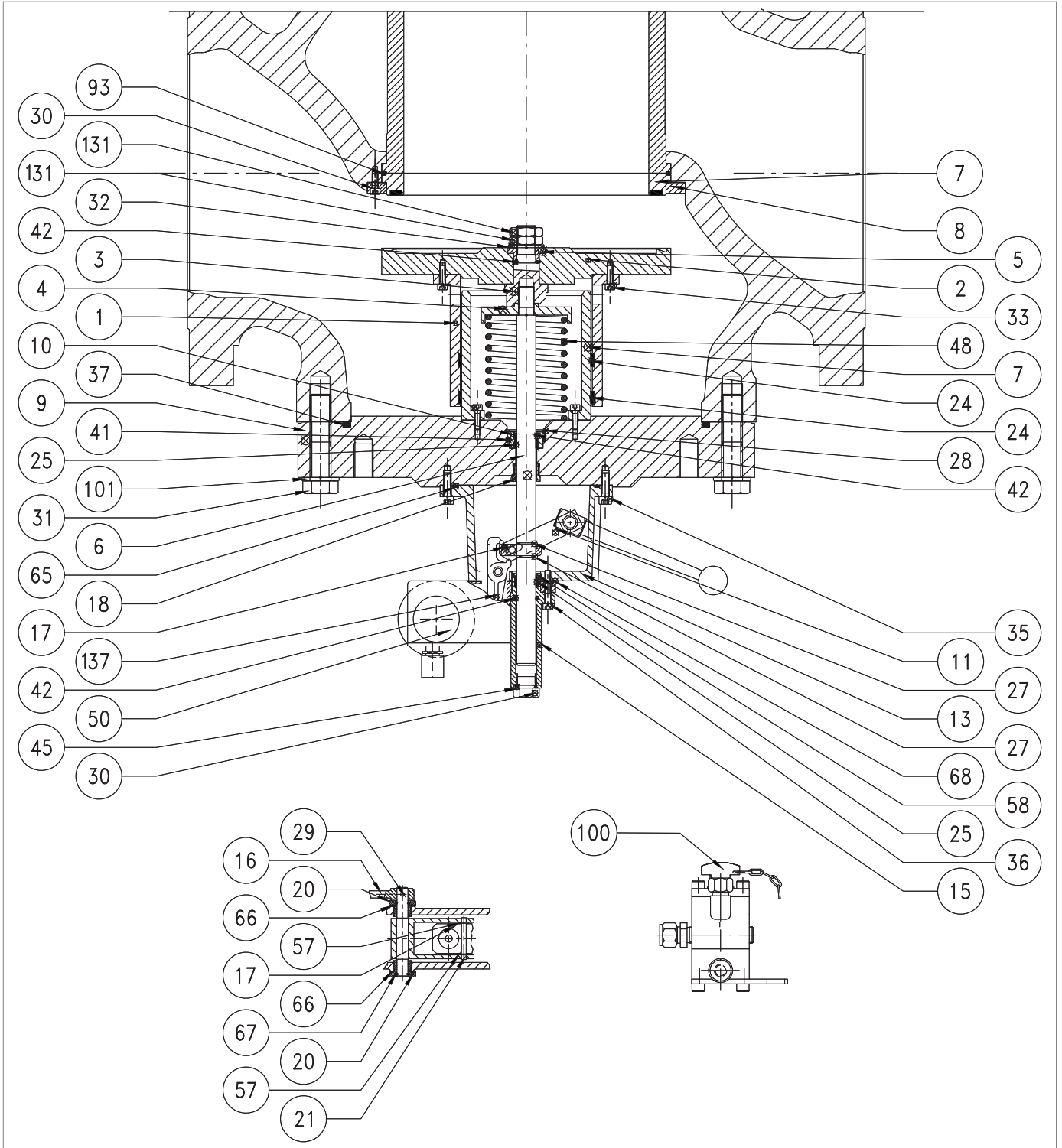

Fig. 9.95. Built-in slam-shut valve SB/82 10"

Step	Action
1	 WARNING! Check that the slam-shut valve is in the shut-off position.
2	Unscrew the minimum spring (Fig. 8.34, ref. 17).  NOTICE! Check that the minimum spring is present.
3	Arm the slam-shut valve by moving the reset lever (16) to the 'OPEN' position.
4	Undo and remove the screws (31).
5	Remove the built-in SB/82 slam-shut valve and place it on an impact-resistant surface.
6	Remove the O-ring (37) from the flange (9) and replace it, taking care to lubricate it with synthetic grease.  NOTICE! Before inserting the replacement O-ring, clean the retaining slots with a cleaning solution.
7	Unscrew and remove the nuts (131) together with the washer (32).
8	Remove the plug (2) together with the plug sleeve (1) and the bush (5).
9	Remove the bush (5).
10	Remove the O-ring (42) from the bush (5) and replace it, lubricating it with synthetic grease.  NOTICE! Before inserting the replacement O-ring, clean the retaining slots with a cleaning solution.
11	Undo and remove the screws (33).
12	Separate the plug (2) from the plug sleeve (1).
13	Remove the I/DWR rings (24) from the plug sleeve (1) and replace them, lubricating them with synthetic grease.  NOTICE! Before fitting the replacement I/DWR ring, clean the retaining slots using a cleaning solution.
14	Unscrew and remove the extension (3) from the stem (6).
15	Remove the spring (48) and the spring support (4).
16	Undo and remove the screws (22) of the pressure switch.
17	Remove the cover (19) and the gasket (29).
18	Undo the side screws (137) inside the control pressure switch.
19	Undo the screws (36).
20	Remove the cup (15).
21	Remove the O-ring (42) from the cup (15) and replace it, taking care to lubricate it with synthetic grease.  NOTICE! Before inserting the replacement O-ring, clean the retaining slots with a cleaning solution.
22	Remove the cap (30).



Built-in slam-shut valve SB/82 10"

Step	Action
23	Remove the O-ring (45) from the cap (30) and replace it, taking care to lubricate it with synthetic grease. ! NOTICE! Before inserting the replacement O-ring, clean the retaining slots with a cleaning solution.
24	Remove the Seeger ring (58) from the cup (15).
25	Remove the I/DWR ring (25) from the cup (15) and replace it, taking care to lubricate it with synthetic grease. ! NOTICE! Before fitting the replacement I/DWR ring, clean the retaining slots using a cleaning solution.
26	Place the Seeger ring (58) in the cup (15).
27	Take out the pressure switch unit. ! NOTICE! For the maintenance procedure of the pressure switch assembly, please refer to par. 9.4.13.
28	Undo and remove the screws (35).
29	Remove the intermediate body (13).
30	Remove the stem (6) taking care not to damage it.
31	Remove the Seeger ring (28) from the flange (9).
32	Remove the bush (10).
33	Remove the O-ring (41) from the flange (9) and replace it, taking care to lubricate it with synthetic grease. ! NOTICE! Before inserting the replacement O-ring, clean the retaining slots with a cleaning solution.
34	Remove the O-ring (42) from the bush (10) and replace it, lubricating it with synthetic grease. ! NOTICE! Before inserting the replacement O-ring, clean the retaining slots with a cleaning solution.
35	Fit the valve seat (10), taking care not to damage the O-ring (41).
36	Place the Seeger ring (28) in the flange (9).
37	Place the stem (6) in the bush (10). ! NOTICE! Lubricate the stem surface with silicone grease.
38	Fit the intermediate body (13).
39	Fit the pressure switch unit.
40	Insert and fix the screws (35) according to the following tightening torque: • 10" : Tab. 9.132 ! NOTICE! Tighten the screws according to the cross diagram in paragraph 9.4.2.2.
41	Fit the cup (15).

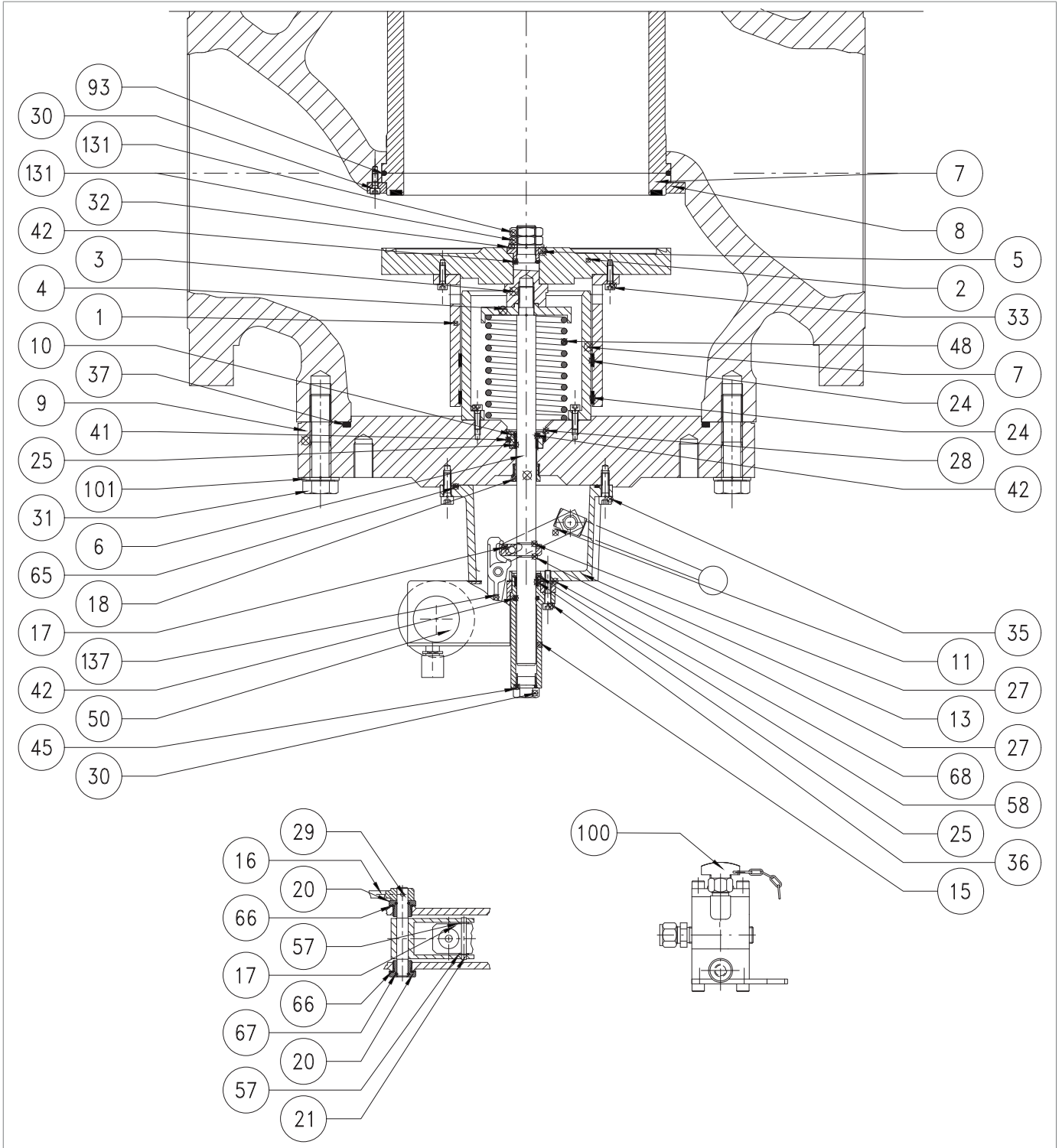

Built-in slam-shut valve SB/82 10"

Step	Action
42	<p>Insert and fix the side screws (137) into the pressure switch according to the following tightening torque:</p> <ul style="list-style-type: none"> 10" : Tab. 9.132 <div style="border: 1px solid black; padding: 5px;"> <p>NOTICE!</p> <p>Tighten the screws according to the cross diagram in paragraph 9.4.2.2.</p> </div>
43	<p>Insert and fix the screws (36) according to the following tightening torque:</p> <ul style="list-style-type: none"> 10" : Tab. 9.132 <div style="border: 1px solid black; padding: 5px;"> <p>NOTICE!</p> <p>Tighten the screws according to the cross diagram in paragraph 9.4.2.2.</p> </div>
44	Fit and secure the cap (30).
45	Fit the gasket (29) and the cover (19).
46	Insert and fix the screws (22).
47	Place the plug sleeve (1) on the plug (2) and
48	<p>Insert and fix the screws (33) according to the following tightening torque:</p> <ul style="list-style-type: none"> 10" : Tab. 9.132 <div style="border: 1px solid black; padding: 5px;"> <p>NOTICE!</p> <p>Tighten the screws according to the cross diagram in paragraph 9.4.2.2.</p> </div>
49	Fit the bush (5) in the plug (2).
50	Put the spring (48) and spring support (4) in place.
51	Position and screw the extension (3).
52	Fit the plug (2) together with the plug sleeve (1).
53	Position and secure the nuts (131), together with the washer (32).
54	Turn the slam-shut valve upside down with the plug (2) facing downwards on an impact-resistant surface.
55	Arm the slam-shut valve by moving the reset lever (16) to the opening position
56	<p>Position the slam-shut valve.</p> <div style="border: 1px solid black; padding: 5px;"> <p>NOTICE!</p> <p>Take care not to press the reset button (see fig. 4.12, ref. 10).</p> </div>
57	<p>Insert and fix the screws (31) according to the following tightening torque:</p> <ul style="list-style-type: none"> 10": tab. 9.129 <div style="border: 1px solid black; padding: 5px;"> <p>NOTICE!</p> <p>Tighten the screws according to the cross diagram in paragraph 9.4.2.2.</p> </div>

Tab. 9.172.

WARNING!
Ensure that all parts have been fitted correctly.

9.4.12 - HP2/2 BYPASS DEVICE MAINTENANCE PROCEDURE

NOTICE!

For more information, please refer to Paragraph 9.4.1.10.

9.4.13 - MAINTENANCE PROCEDURE FOR PRESSURE SWITCHES MOD. 100

9.4.13.1 - PRESSURE SWITCH MOD. 101M/101MH

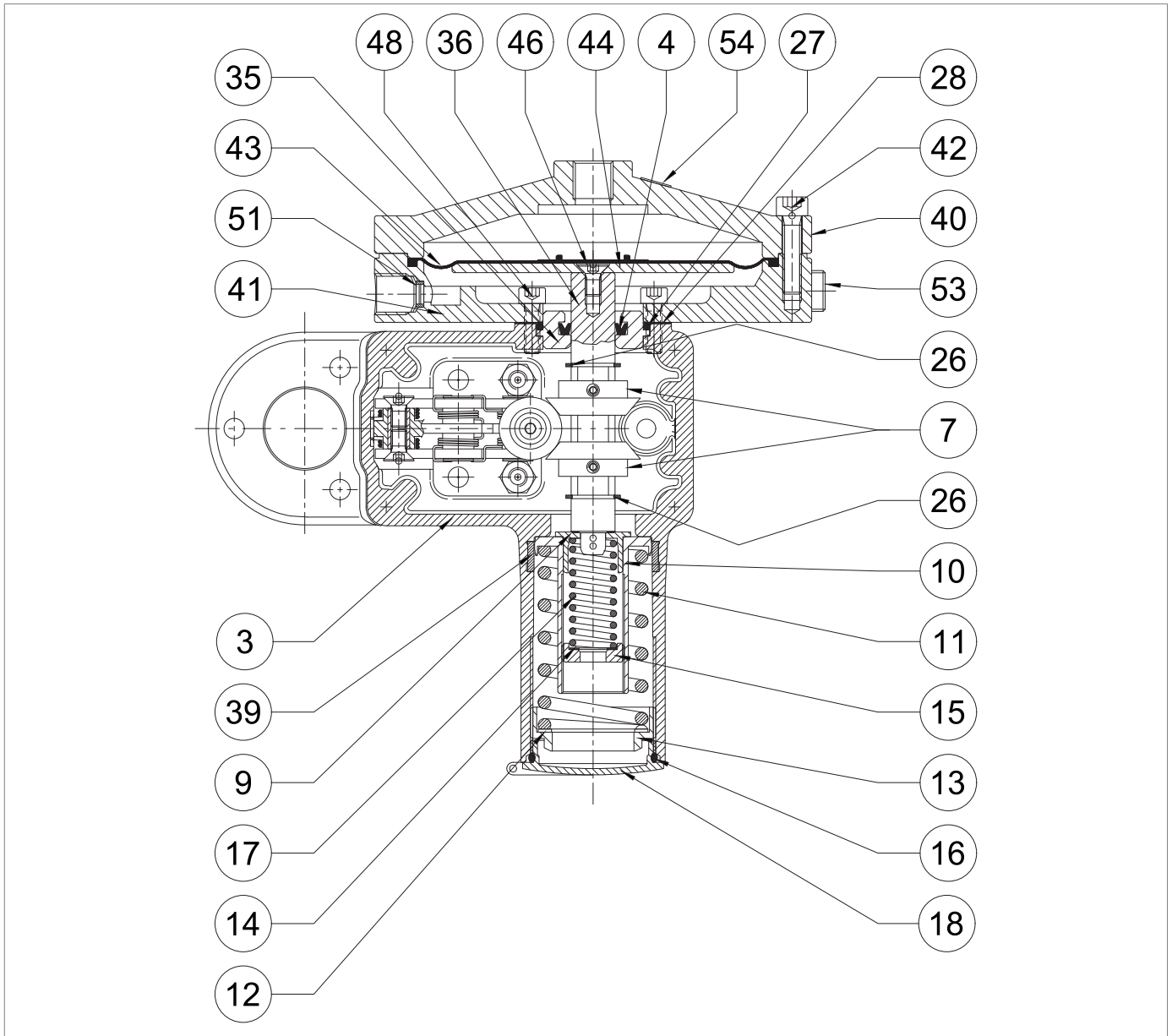
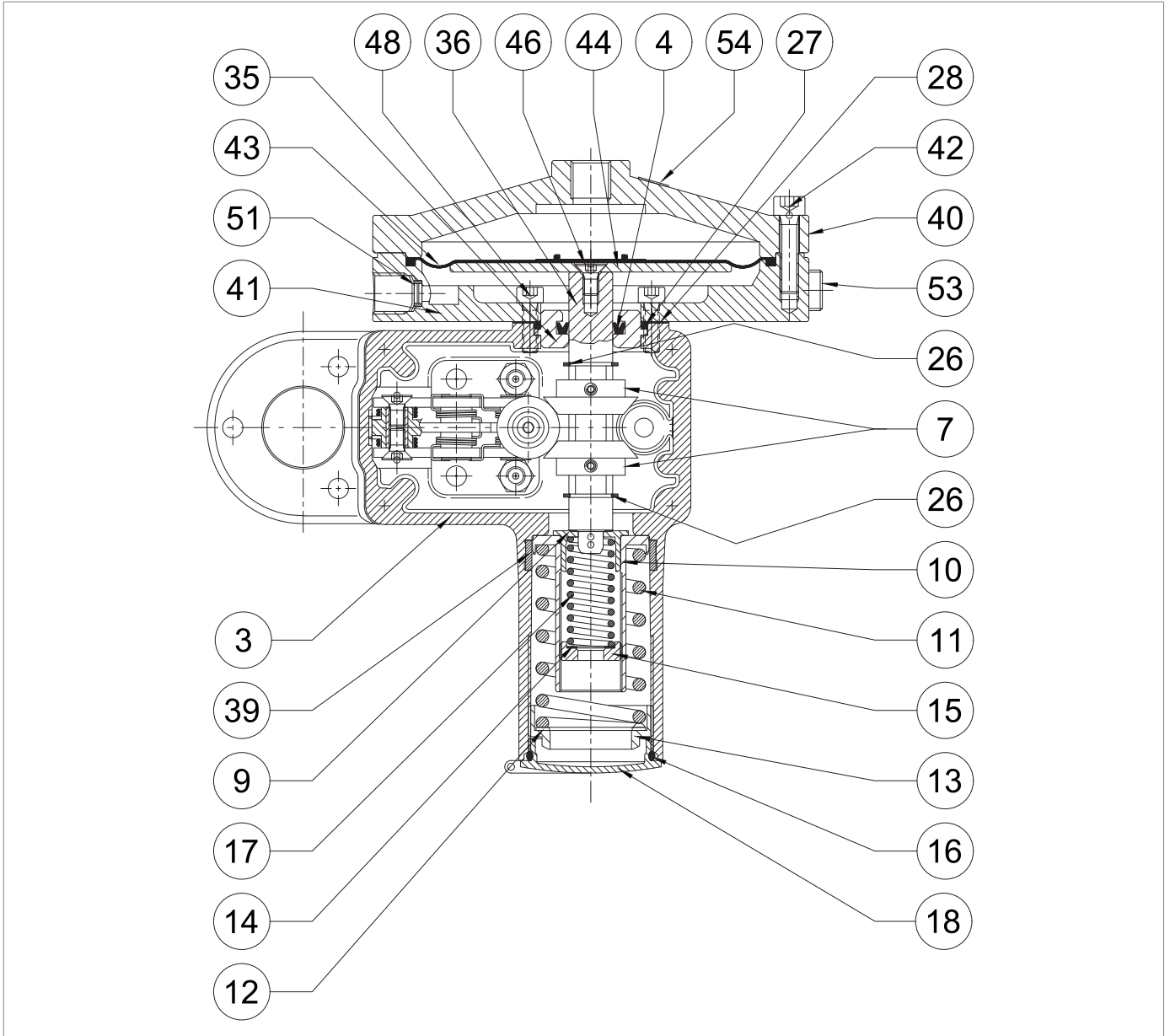





Fig. 9.96. Pressure switch Mod. 101M/101MH

Step	Action
1	Unscrew and remove the cap (18).
2	Remove the O-ring (16) from the cover (18) and replace it, lubricating it with synthetic grease. ! NOTICE! Before inserting the replacement O-ring, clean the retaining slots with a cleaning solution.
3	Completely release the spring (11) by adjusting the ring nut (13).
4	Completely release the minimum pressure spring (17) by adjusting the ring nut (15). ! NOTICE! The minimum spring may not be installed.
5	Remove the ring nut (13), the spring (11) and the spring holder (10).
6	Remove the I/DWR ring (39) from the pressure switch sleeve and replace it, lubricating it with synthetic grease. ! NOTICE! Before inserting the replacement I/DWR ring, clean the retaining slots with a cleaning solution.
7	Undo and remove the screws (42).
8	Remove the upper cover (40).
9	Remove and replace the diaphragm (43), taking care to lubricate the lanyard with synthetic grease. ! NOTICE! Before inserting the replacement diaphragm, clean the retaining slots with a cleaning solution.
10	Unscrew the screw (46) while holding the diaphragm protection disc (44) in place.
11	Remove the diaphragm protection disc (44).
12	Undo and remove the screws (48).
13	Remove the flange (41).
14	Remove and replace the gasket (28).
15	Pull out the stem guide (35).
16	Remove and replace O-ring (27), lubricating it with synthetic grease. ! NOTICE! Before inserting the replacement O-ring, clean the retaining slots with a cleaning solution.
17	Remove and replace the U-ring (4), lubricating it with synthetic grease. ! NOTICE! Before inserting the replacement U-ring, clean the retaining slots with a cleaning solution.
18	Position the stem guide (35).
19	Position the gasket (28).
20	Fit the flange (41).



Pressure switch Mod. 101M/101MH

Step	Action
21	Insert and fasten screws (48) according to torque: <ul style="list-style-type: none"> Mod. 101M/101MH: Tab. 9.137
22	Position the diaphragm position disc (44).
23	Insert and fasten the screw (46) according to torque: <ul style="list-style-type: none"> Mod. 101M/101MH: Tab. 9.137 <div style="border: 1px solid blue; padding: 5px; margin-top: 5px;">  NOTICE! During this step, hold the diaphragm protection disc (44) in place. </div>
24	Fit the diaphragm (43).
25	Fit the lid (40).
26	Insert and fasten screws (42) according to torque: <ul style="list-style-type: none"> Mod. 101M/101MH: Tab. 9.137
27	Completely release the maximum pressure spring (11) by adjusting the ring nut (13). <div style="border: 1px solid blue; padding: 5px; margin-top: 5px;">  NOTICE! For spring calibration, please refer to chapter “13 - Calibration tables”. </div>
28	Position the minimum spring (17) by adjusting the ring nut (15). <div style="border: 1px solid blue; padding: 5px; margin-top: 5px;">  NOTICE! <ul style="list-style-type: none"> Check that it is present; For spring calibration, please refer to chapter “13 - Calibration tables”. </div>
29	Insert and fix the cap (18).

Tab. 9.173.

 **WARNING!**

Ensure that all parts have been fitted correctly.

9.4.13.2 - PRESSURE SWITCH MOD. 102M/102MH

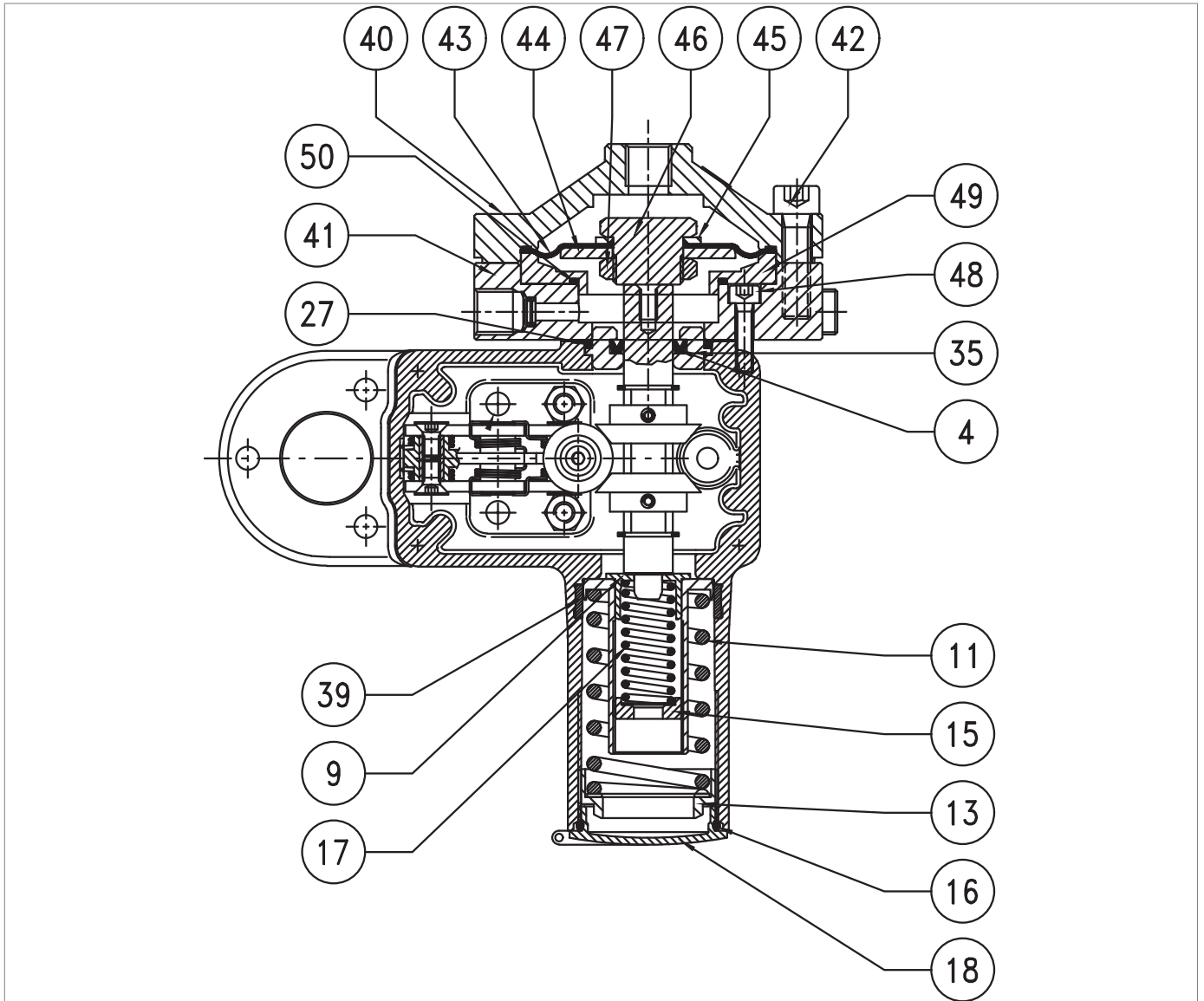
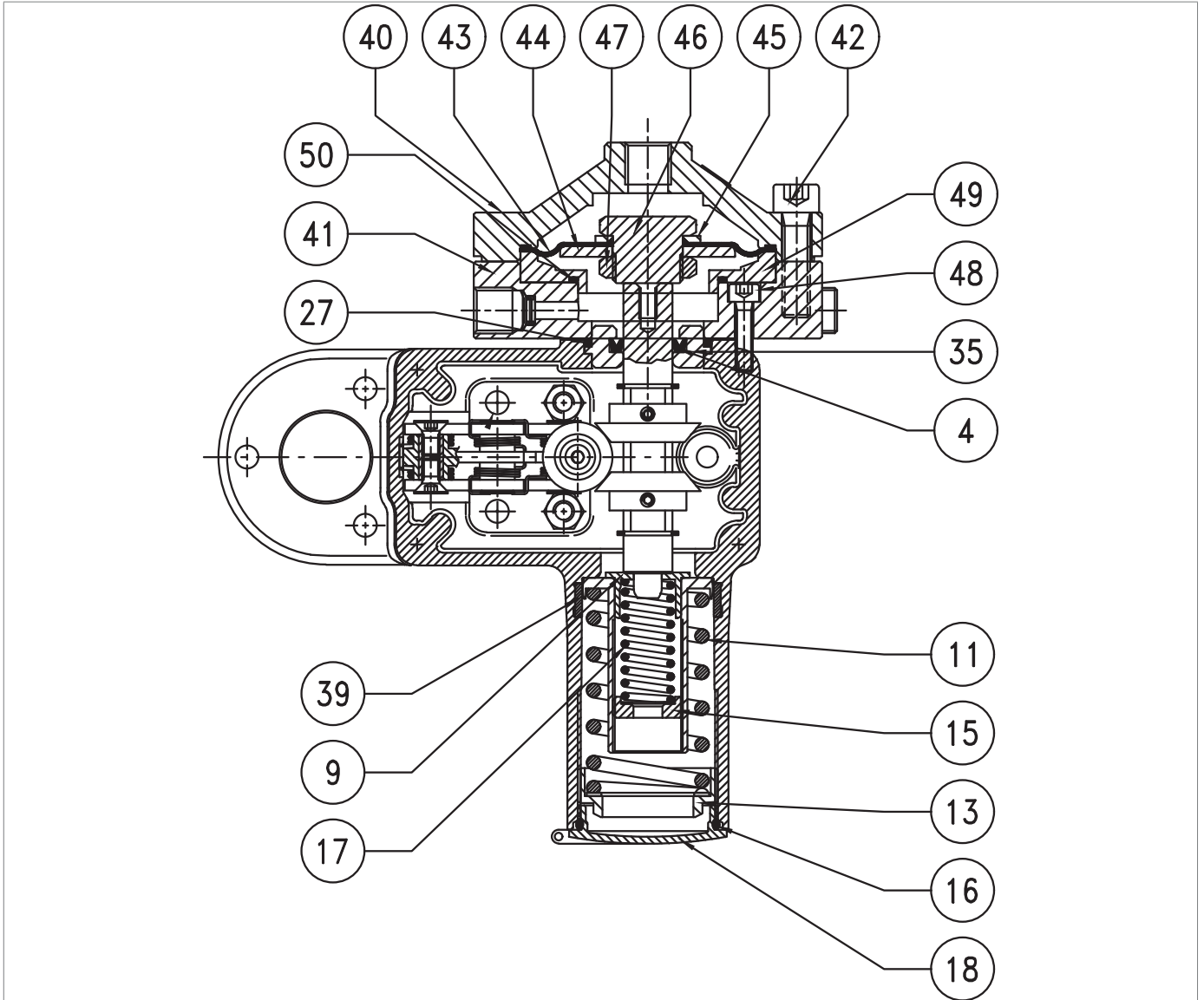

Fig. 9.97. Pressure switch Mod. 102M/102MH

Step	Action
1	Unscrew and remove the cap (18).
2	Remove the O-ring (16) from the cover (18) and replace it, lubricating it with synthetic grease. ! NOTICE! Before inserting the replacement O-ring, clean the retaining slots with a cleaning solution.
3	Completely release the spring (11) by adjusting the ring nut (13).
4	Completely release the minimum pressure spring (17) by adjusting the ring nut (15). ! NOTICE! The minimum spring may not be installed.
5	Remove the ring nut (13), the spring (11) and the spring support (17).
6	Remove the I/DWR ring (39) from the pressure switch sleeve and replace it, lubricating it with synthetic grease. ! NOTICE! Before inserting the replacement I/DWR ring, clean the retaining slots with a cleaning solution.
7	Undo and remove the screws (42).
8	Remove the upper cover (40).
9	Take out the diaphragm unit (43, 44, 45, 46, 47).
10	Unscrew the nut (47).
11	Remove the diaphragm protection disc (44).
12	Remove and replace the diaphragm (43), lubricating the lanyard with synthetic grease. ! NOTICE! Before inserting the replacement diaphragm, clean the retaining slots with a cleaning solution.
13	Fit the diaphragm protection disc (44).
14	Tighten and secure the nut (47), according to torque: <ul style="list-style-type: none"> • Mod. 102M/102MH: tab. 9.135
15	Remove the ring (49).
16	Undo and remove the screws (48).
17	Remove the lower lid (41).
18	Remove the O-ring (50) from the nut (49) and replace it, lubricating it with synthetic grease. ! NOTICE! Before inserting the replacement O-ring, clean the retaining slots with a cleaning solution.
19	Remove the bush (35).
20	Remove the O-ring (27) from the bush (35) and replace it, lubricating it with synthetic grease. ! NOTICE! Before inserting the replacement O-ring, clean the retaining slots with a cleaning solution.



Pressure switch Mod. 102M/102MH

Step	Action
21	<p>Remove the U-shaped ring (4) from the bush (35) and replace it, lubricating it with synthetic grease.</p> <p>! NOTICE! Before inserting the replacement U-ring, clean the retaining slots with a cleaning solution.</p>
22	<p>Position the bush (35) together with the O-ring (27).</p> <p>! NOTICE! Before inserting the bush (35), lubricate the inner surface with silicone grease.</p>
23	<p>Fit the lower cover (41).</p> <p>! NOTICE! Make sure there is a gasket between the lower cover and the pressure switch body.</p>
24	<p>Insert and fasten screws (48) according to torque:</p> <ul style="list-style-type: none"> • Mod. 102M/102MH: Tab. 9.138 <p>! NOTICE! Tighten the screws according to the cross diagram in paragraph 9.4.2.2.</p>
25	Insert the ring (49).
26	Put the diaphragm unit in place (43, 44, 45, 46, 47).
27	Fit the lid (40).
28	<p>Insert and fasten screws (42) according to torque:</p> <ul style="list-style-type: none"> • Mod. 102M/102MH: Tab. 9.138 <p>! NOTICE! Tighten the screws according to the cross diagram in paragraph 9.4.2.2.</p>
29	<p>Completely release the maximum pressure spring (11) by adjusting the ring nut (13).</p> <p>! NOTICE! For spring calibration, please refer to chapter “13 - Calibration tables”.</p>
30	<p>Position the minimum spring (17) by adjusting the ring nut (15).</p> <p>! NOTICE!</p> <ul style="list-style-type: none"> • Check that it is present; • For spring calibration, please refer to chapter “13 - Calibration tables”.
31	Insert and fix the cap (18).

Tab. 9.174.

! WARNING!

Ensure that all parts have been fitted correctly.

9.4.13.3 - PRESSURE SWITCH MOD. 103M/103MH

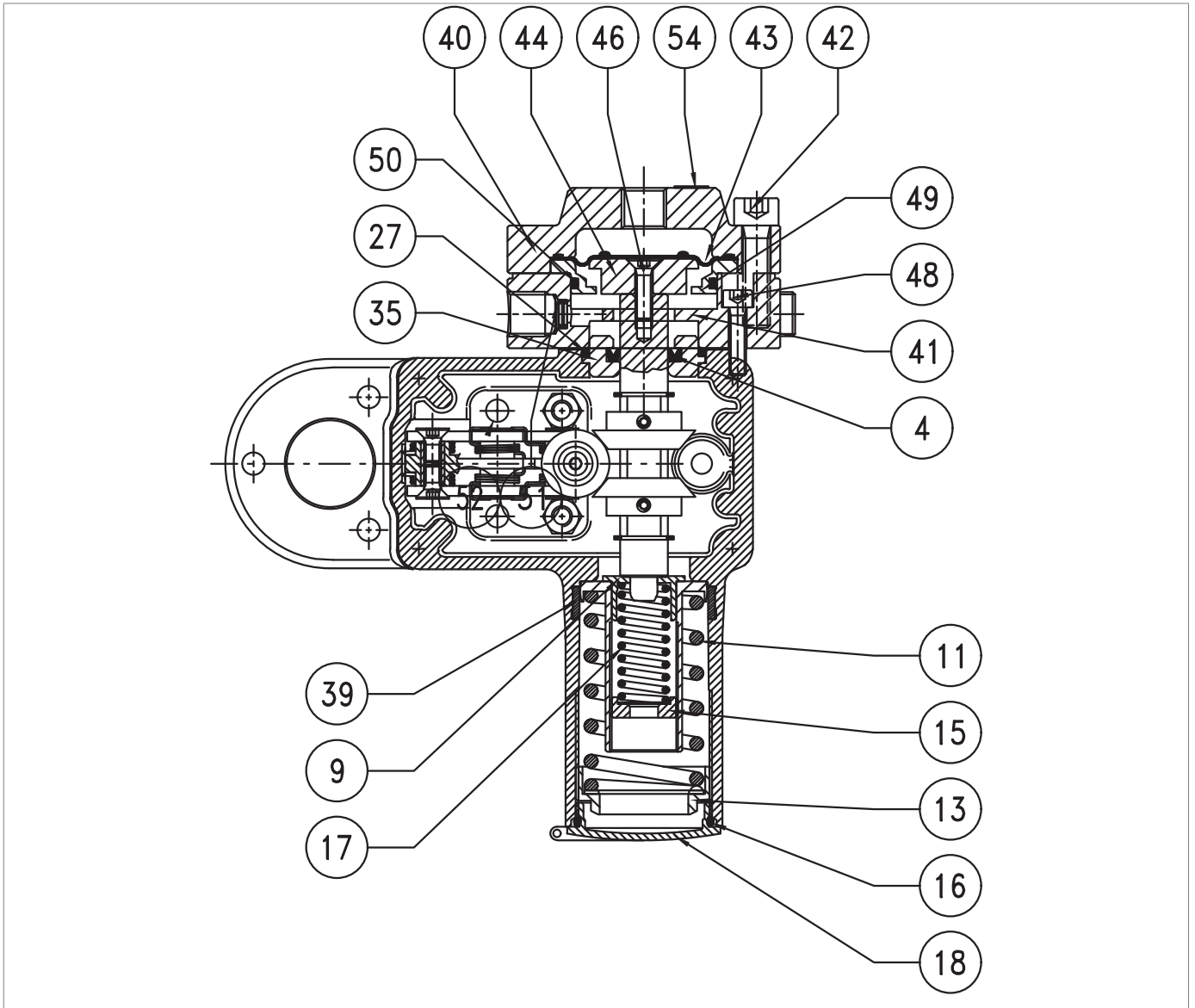
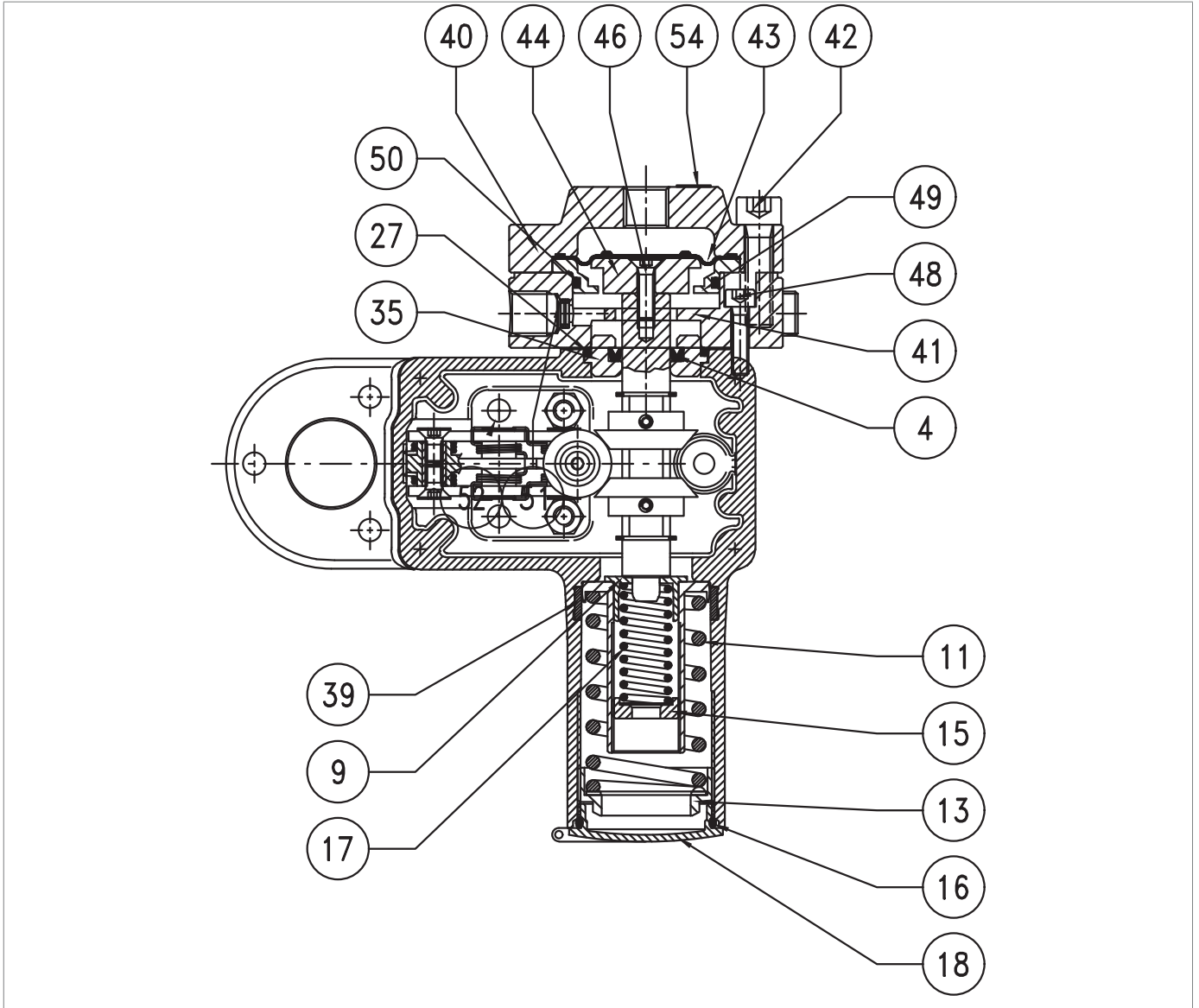

Fig. 9.98. Pressure switch Mod. 103M/103MH

Step	Action
1	Unscrew and remove the cap (18).
2	Remove the O-ring (16) from the cover (18) and replace it, lubricating it with synthetic grease. ! NOTICE! Before inserting the replacement O-ring, clean the retaining slots with a cleaning solution.
3	Completely release the spring (11) by adjusting the ring nut (13).
4	Completely release the minimum pressure spring (17) by adjusting the ring nut (15). ! NOTICE! The minimum spring may not be installed.
5	Remove the ring nut (13), the spring (11) and the spring support (17).
6	Remove the I/DWR ring (39) from the pressure switch sleeve and replace it, lubricating it with synthetic grease. ! NOTICE! Before fitting the replacement I/DWR ring, clean the retaining slots using a cleaning solution.
7	Undo and remove the screws (42).
8	Remove the upper cover (40).
9	Remove and replace the diaphragm (43), lubricating the lanyard with synthetic grease. ! NOTICE! Before inserting the replacement diaphragm, clean the retaining slots with a cleaning solution.
10	Undo and remove the screws (46).
11	Remove diaphragm protection disc (44).
12	Remove the ring (49).
13	Remove the O-ring (50) from the ring (49) and replace it. ! NOTICE! Before inserting the replacement O-ring, clean the retaining slots with a cleaning solution.
14	Undo and remove the screws (48).
15	Remove the lower lid (41).
16	Remove the bush (35).
17	Remove the O-ring (27) from the bush (35) and replace it, lubricating it with synthetic grease. ! NOTICE! Before inserting the replacement O-ring, clean the retaining slots with a cleaning solution.
18	Remove the U-shaped ring (4) from the bush (35) and replace it, lubricating it with synthetic grease. ! NOTICE! Before inserting the replacement U-ring, clean the retaining slots with a cleaning solution.



Pressure switch Mod. 103M/103MH

Step	Action
19	Position the bush (35) together with the O-ring (27). NOTICE! Before inserting the bush (35), lubricate the internal surface with silicone grease.
20	Fit the lower cover (41).
21	Insert and fix the screws (48) according to the following tightening torque: • Mod. 103M/103MH: Tab. 9.139 NOTICE! • Tighten the screws according to the cross diagram in paragraph 9.4.2.2; • Make sure there is a gasket between the lower cover and the pressure switch body.
22	Insert the ring (49).
23	Fit the diaphragm protection disc (44).
24	Insert and fix the screws (46) according to the following tightening torque: • Mod. 103M/103MH: Tab. 9.139 NOTICE! • Tighten the screws according to the cross diagram in paragraph 9.4.2.2; • Before inserting the screw (46), apply thread locking glue.
25	Fit the diaphragm (43).
26	Fit the lid (40).
27	Insert and fix the screws (42) according to the following tightening torque: • Mod. 103M/103MH: Tab. 9.139 NOTICE! Tighten the screws according to the cross diagram in paragraph 9.4.2.2.
28	Completely release the maximum pressure spring (11) by adjusting the ring nut (13). NOTICE! For spring calibration, please refer to chapter “13 - Calibration tables”.
29	Position the minimum spring (17) by adjusting the ring nut (15). NOTICE! • Check that it is present; • For spring calibration, please refer to chapter “13 - Calibration tables”.
30	Insert and fix the cap (18).

Tab. 9.175.

WARNING!

Ensure that all parts have been fitted correctly.

9.4.14 - LINE OFF 2.0 DISCONNECTION

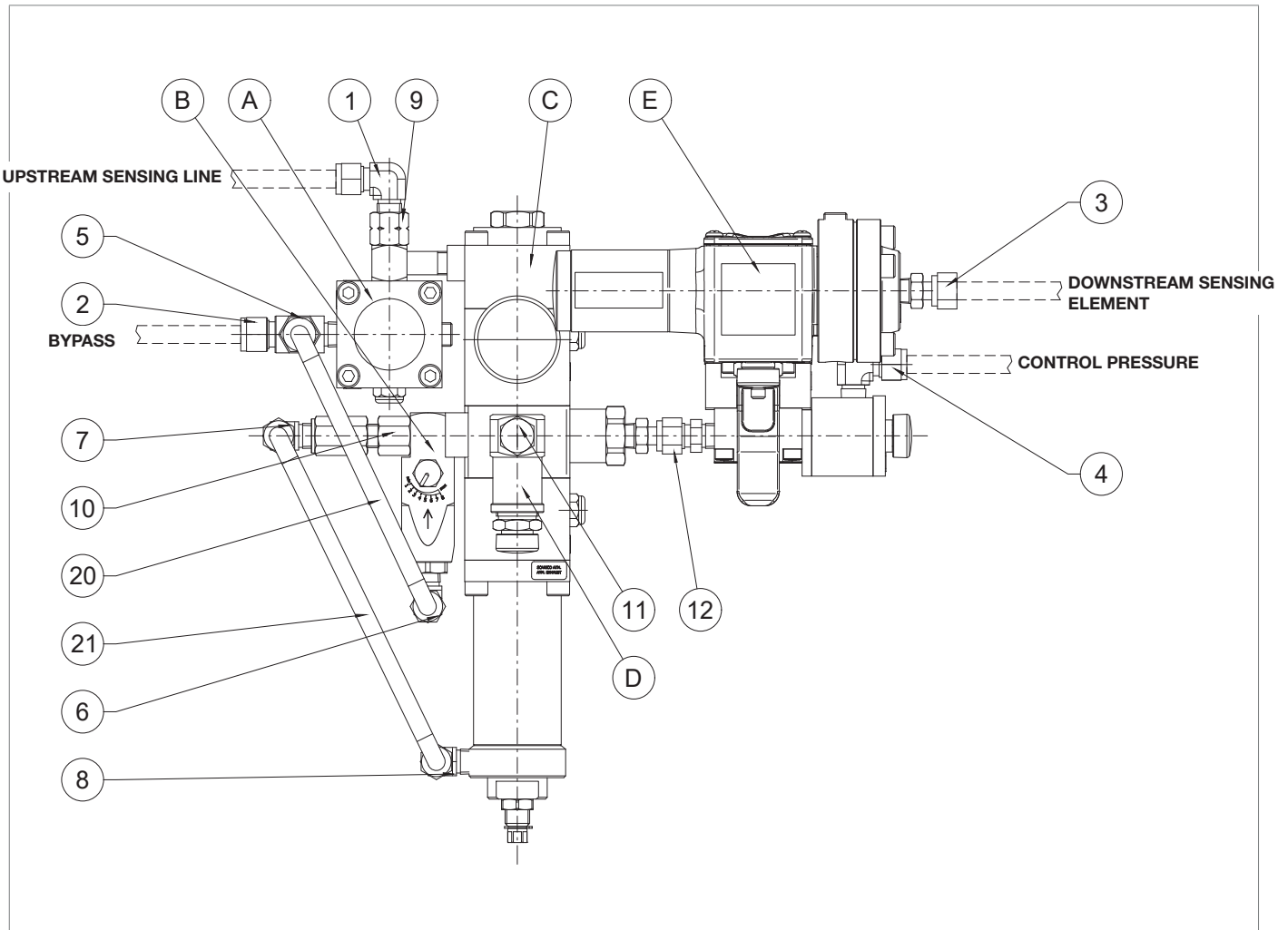

Fig. 9.99. LINE OFF 2.0

To disconnect, proceed as in Tab. 9.176 (see Fig. 9.99):

Step	Action
1	Disconnect the pipes from the fittings (1, 2, 3, 4).
2	Unscrew and remove the fixing screw to disconnect the LINE OFF 2.0.
3	Disconnect the pipe (20) from the fittings (5, 6).
4	Disconnect the pipe (21) from the fittings (7, 8).
5	Remove assembly "A" (bypass device HP2/2) and adjust the fitting (9).
6	Remove assembly "B" (throttle valve AR100) and adjust the fitting (10).
7	Remove the assembly "D" (safety valve VS/FI) by acting on the screw (11).
8	Remove assembly "E" (valve 3/2 and control pressure switch) from assembly "C" (regulator R44/SS) and adjust the fitting (12).

Tab. 9.176.

9.4.15 - MAINTENANCE SLAM-SHUT VALVE INCORPORATED HB/97

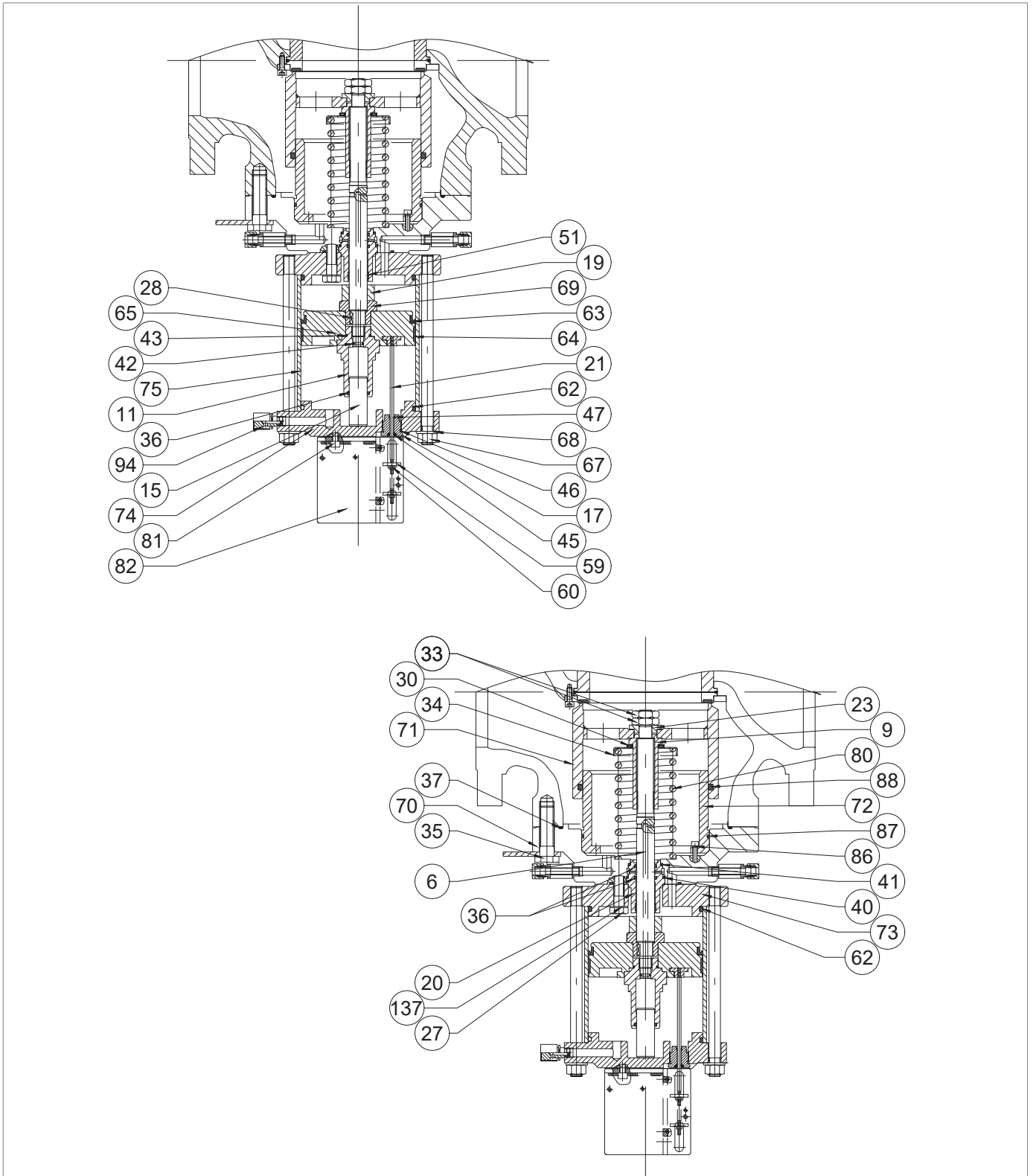







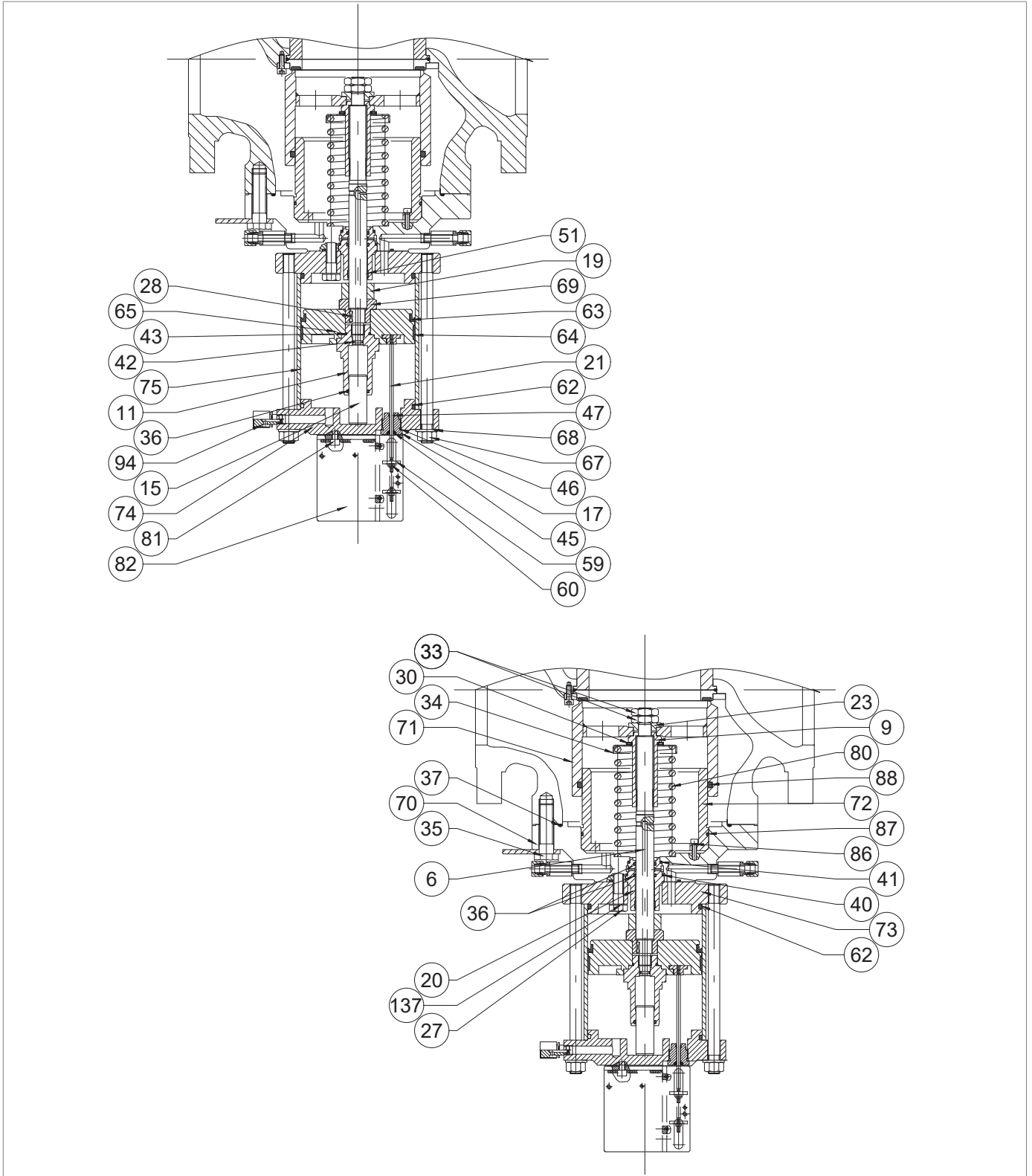

Fig. 9.100. HB/97 built-in slam-shut valve

Step	Action
1	 WARNING! Check that the slam-shut valve is in the shut-off position.
2	 NOTICE! To disconnect the LINE OFF 2.0 device, refer to paragraph 9.4.14.
3	Undo and remove the screws (81).
4	Remove the bracket (82).
5	Unscrew and remove the nut (59) together with the indicator disc (60).
6	Unscrew and remove the nut (17).
7	Pull out the indicator rod (21).
8	Remove the guide O-ring (45) from the nut (17) and replace it, lubricating it with synthetic grease.  NOTICE! Before inserting the replacement guide ring, clean the retaining slots with a cleaning solution.
9	Remove the O-rings (46, 47) from the nut (17) and replace them, lubricating them with synthetic grease.  NOTICE! Before inserting the replacement O-rings, clean the retaining slots with a cleaning solution.
10	Undo and remove the screws (35).  NOTICE! In this step, support the built-in SB/97 slam-shut valve to prevent any falls.
11	Remove the HB/97 built-in slam-shut valve and fit it vertically with the plug (71) on an anti-shock surface.
12	Unscrew and remove the nuts (67) together with the washers (68).
13	Remove the flange (74).  NOTICE! Check that the vent (94) is not clogged by dirt.
14	Remove the O-ring (62) from the flange (74) and replace it, lubricating it with synthetic grease.  NOTICE! Before inserting the replacement O-ring, clean the retaining slots with a cleaning solution.
15	Remove the plating (75).
16	Fit the HB/97 built-in slam-shut valve sideways.
17	Unscrew and remove the nuts (33) together with the washer (23).
18	Remove the plug (71) and place it on an anti-shock surface.
19	ONLY VALID FOR 4" Remove the O-ring (88) from the plug (70) and replace it, lubricating it with synthetic grease.  NOTICE! Before inserting the O-ring, clean the retaining slots with a cleaning solution.







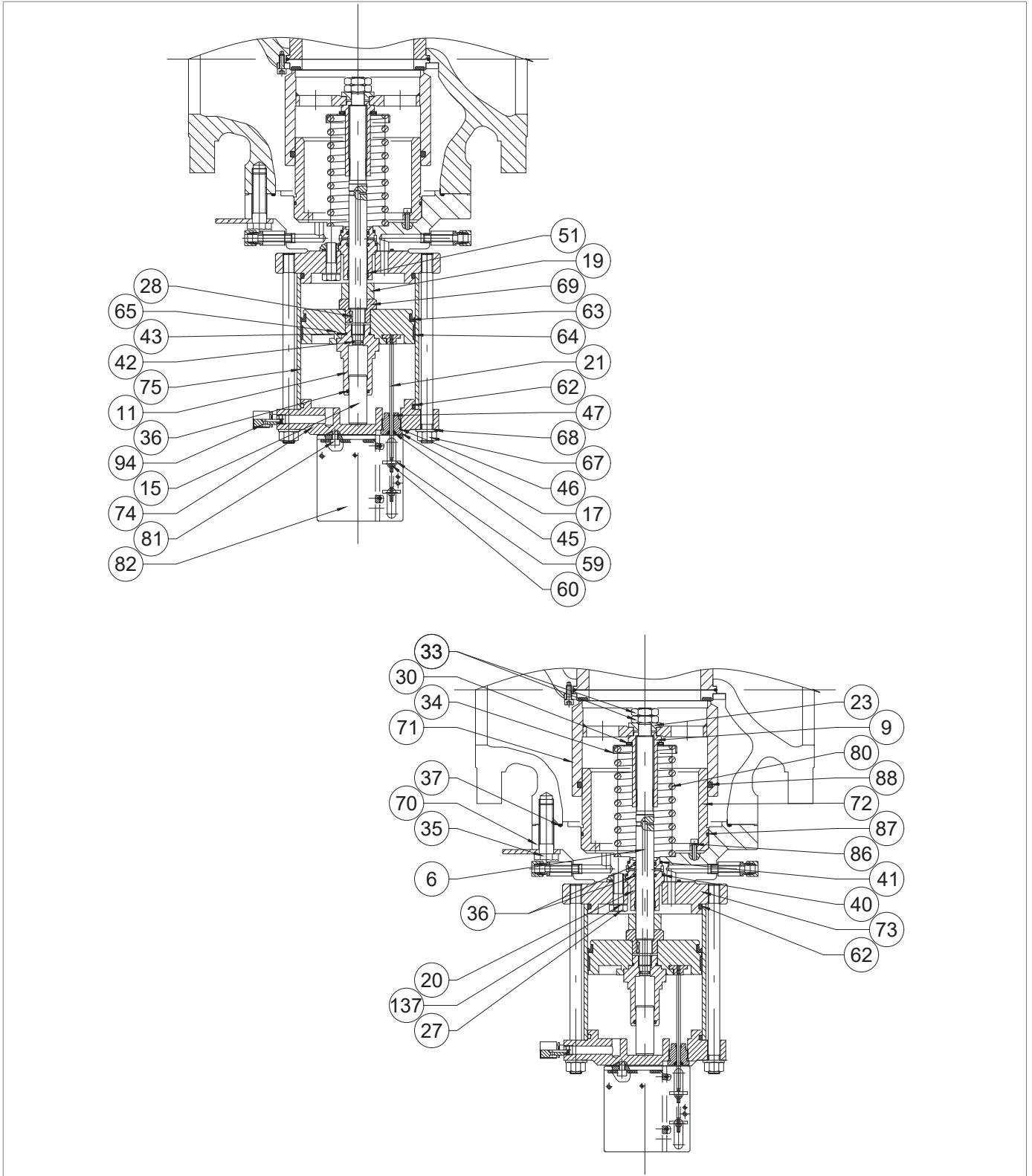

HB/97 built-in slam-shut valve

Step	Action
20	ONLY VALID FOR 4" Remove the I/DWR rings (76) from the plug guide (70) and replace it, lubricating it with synthetic grease.
	<div style="border: 1px solid black; padding: 5px;">  NOTICE! Before inserting the I/DWR rings, clean the retaining slots with a cleaning solution. </div>
21	Remove the O-ring (88) from the plug (71) and replace it, lubricating it with synthetic grease.
	<div style="border: 1px solid black; padding: 5px;">  NOTICE! Before inserting the replacement O-ring, clean the retaining slots with a cleaning solution. </div>
22	While keeping the nut (69) in place, unscrew and remove the lock nut (9).
	<div style="background-color: #f4a460; padding: 5px;">  WARNING! By unscrewing the lock nut (9), the spring (80) is released. </div>
23	Remove the radial bearing (30).
24	Remove the spring support (34) and the spring (80).
25	While keeping the nut (69) in place, unscrew and remove the balancing piston guide (11).
26	Remove the balancing piston (15) from the balancing piston guide (11).
27	Remove the O-rings (36, 43) from the balancing piston guide (11) and replace them, taking care to lubricate them with synthetic grease.
	<div style="border: 1px solid black; padding: 5px;">  NOTICE! Before inserting the replacement O-rings, clean the retaining slots with a cleaning solution. </div>
28	Fit the balancing piston (15) from the balancing piston guide (11).
29	Take out the piston (65).
30	Remove the U-shaped ring (63) from the bush (65) and replace it, lubricating it with synthetic grease.
	<div style="border: 1px solid black; padding: 5px;">  NOTICE! <ul style="list-style-type: none"> Before inserting the replacement U-ring, clean the retaining slots with a cleaning solution. The concave part must face the flange (73). </div>
31	Remove the I/DWR ring (64) from the piston (65) and replace it, lubricating it with synthetic grease.
	<div style="border: 1px solid black; padding: 5px;">  NOTICE! Before inserting the replacement I/DWR ring, clean the retaining slots with a cleaning solution. </div>
32	Take out the nut (69).
33	ONLY VALID FOR 6" ÷ 10" Remove the spacer (19).
	34
35	Remove the flange (73).



HB/97 built-in slam-shut valve

Step	Action
36	Remove the O-ring (62) from the flange (73) and replace it, lubricating it with synthetic grease. <div style="border: 1px solid black; padding: 2px;">  NOTICE! Before inserting the replacement O-ring, clean the retaining slots with a cleaning solution. </div>
37	Remove the stem guide (20) together with the stem (6) and the key (28).
38	Remove the stem (6) from the stem guide (20).
39	Remove the I/DWR ring (51) from the stem guide (20) and replace it, lubricating it with synthetic grease. <div style="border: 1px solid black; padding: 2px;">  NOTICE! Before fitting the replacement I/DWR ring, clean the retaining slots using a cleaning solution. </div>
40	Remove the O-rings (36) from the stem guide (20) and replace them, lubricating them with synthetic grease. <div style="border: 1px solid black; padding: 2px;">  NOTICE! Before inserting the replacement O-rings, clean the retaining slots with a cleaning solution. </div>
41	Remove the O-rings (40, 41) from the stem guide (20) and replace them, lubricating them with synthetic grease. <div style="border: 1px solid black; padding: 2px;">  NOTICE! Before inserting the replacement O-rings, clean the retaining slots with a cleaning solution. </div>
42	Remove the O-ring (42) from the stem (6) and replace it, lubricating it with synthetic grease. <div style="border: 1px solid black; padding: 2px;">  NOTICE! Before inserting the replacement O-ring, clean the retaining slots with a cleaning solution. </div>
43	VALID ONLY FOR 6"- 10" Undo and remove the screws (86).
44	VALID ONLY FOR 6"- 10" Take out the plug guide (72). <div style="border: 1px solid black; padding: 2px;">  NOTICE! In this step, tighten some M6x50 screws into the threaded holes of the plug guide to remove it vertically. </div>
45	Remove the screws M6x50.
46	VALID ONLY FOR 6"- 10" Remove the O-ring (87) from the plug guide (72) and replace it, lubricating it with synthetic grease. <div style="border: 1px solid black; padding: 2px;">  NOTICE! Before inserting the replacement O-ring, clean the retaining slots with a cleaning solution. </div>
47	VALID ONLY FOR 6"- 10" Put the plug guide (72) in place.

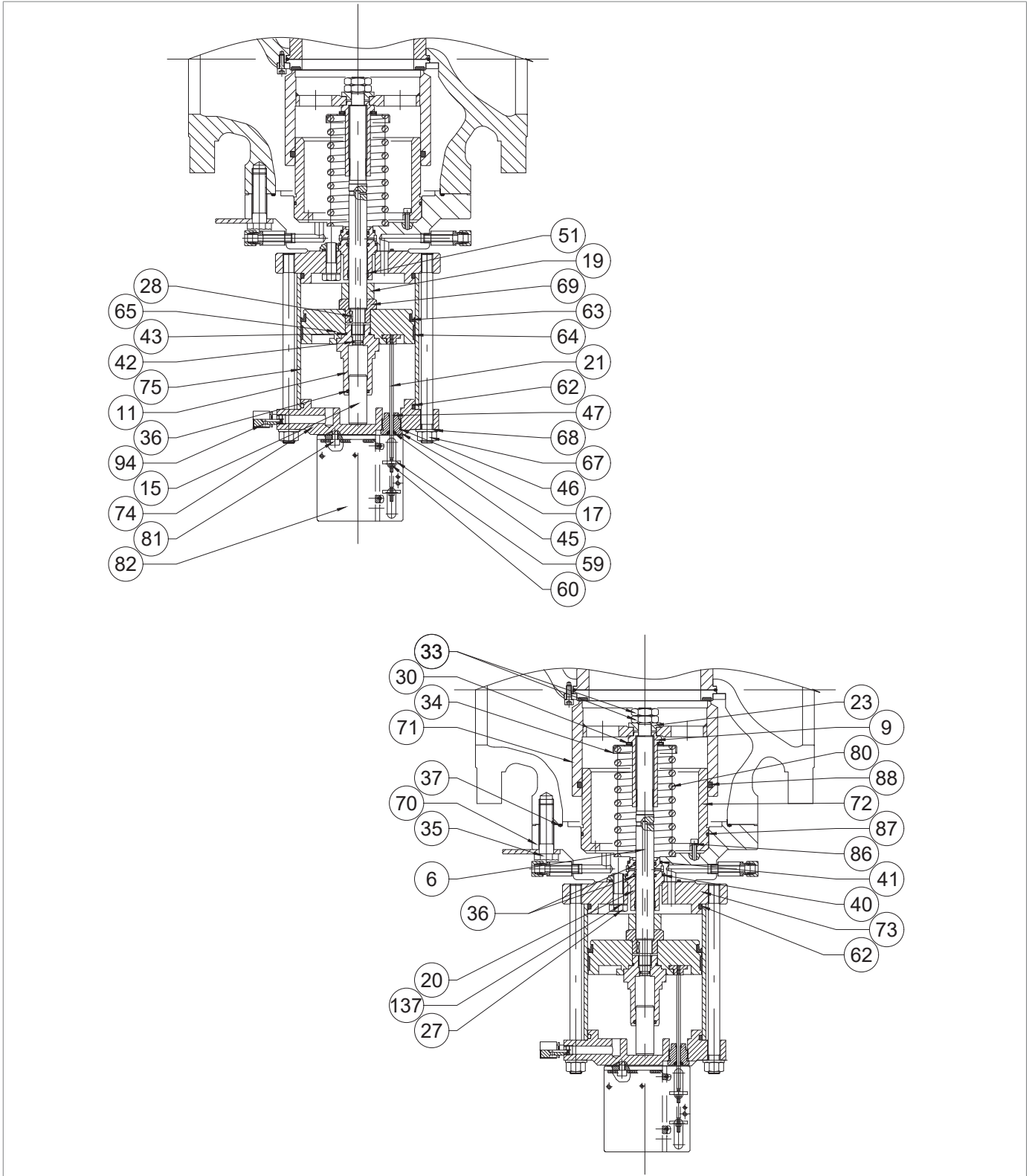

HB/97 built-in slam-shut valve

Step	Action
48	<p>VALID ONLY FOR 6"- 10"</p> <p>Insert and fix the screws (86) according to the following tightening torques:</p> <ul style="list-style-type: none"> • 6" : Tab. 9.134 • 8" : Tab. 9.135 • 10" : Tab. 9.136 <p>NOTICE!</p> <p>Tighten the screws according to the cross diagram in paragraph 9.4.2.2.</p>
49	<p>Insert the stem (6) together with the key (28) in the stem guide (20).</p> <p>NOTICE!</p> <p>Clean and lubricate the stem surface with silicone grease; make sure that the key (28) is in the correct position in the stem (6).</p>
50	<p>Insert the stem guide (20) together with the stem (6) into the plug guide (70).</p>
51	<p>Fit the flange (73).</p> <p>NOTICE!</p> <p>Match the chamber pressurisation hole with the plug guide hole (70)</p>
52	<p>Insert and fix the screws (27) together with the washers (137) according to the following tightening torques:</p> <ul style="list-style-type: none"> • 4" : Tab. 9.130 • 6" : Tab. 9.134 • 8" : Tab. 9.135 • 10" : Tab. 9.136 <p>NOTICE!</p> <p>Tighten the screws according to the cross diagram in paragraph 9.4.2.2.</p>
53	<p>VALID ONLY FOR 6"- 10"</p> <p>Insert the spacer (19).</p>
54	<p>Insert the nut (69).</p> <p>NOTICE!</p> <p>Make sure that the key (28) is present and correctly positioned in the stem (6).</p>
55	<p>Fit the piston (65).</p>
56	<p>Keeping the nut (69) in position, insert and fix the balancing piston guide (11) according to the tightening torques:</p> <ul style="list-style-type: none"> • 4" : Tab. 9.130 • 6" : Tab. 9.134 • 8" : Tab. 9.135 • 10" : Tab. 9.136
57	<p>Position the spring (80), together with the spring support (34) and the radial bearing (30).</p>
58	<p>Keeping the nut (69) in position, insert and fix the nut (9) according to the following tightening torques:</p> <ul style="list-style-type: none"> • 4" : Tab. 9.130 • 6" : Tab. 9.134 • 8" : Tab. 9.135 • 10" : Tab. 9.136
59	<p>Fit the plug (71).</p>

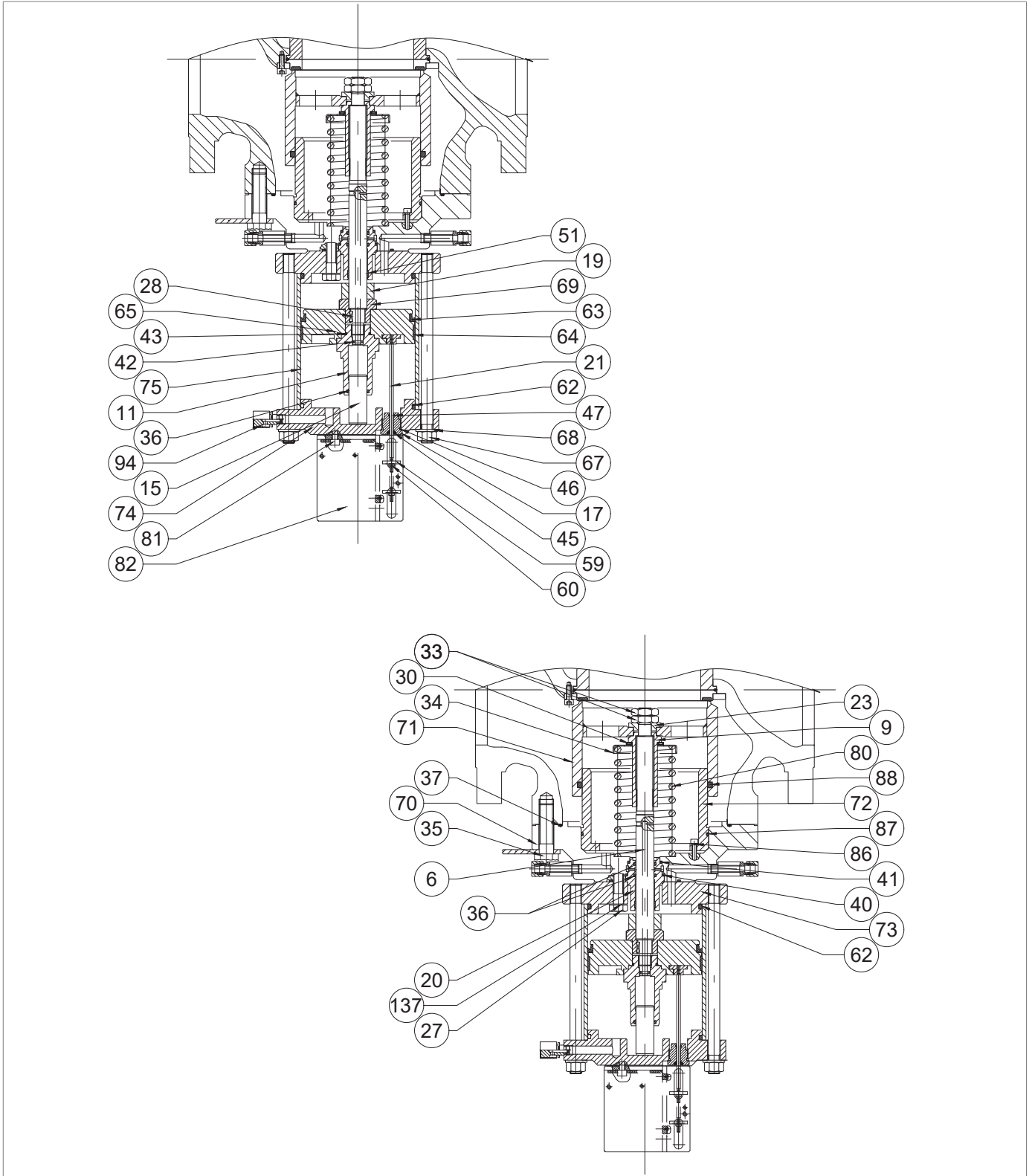

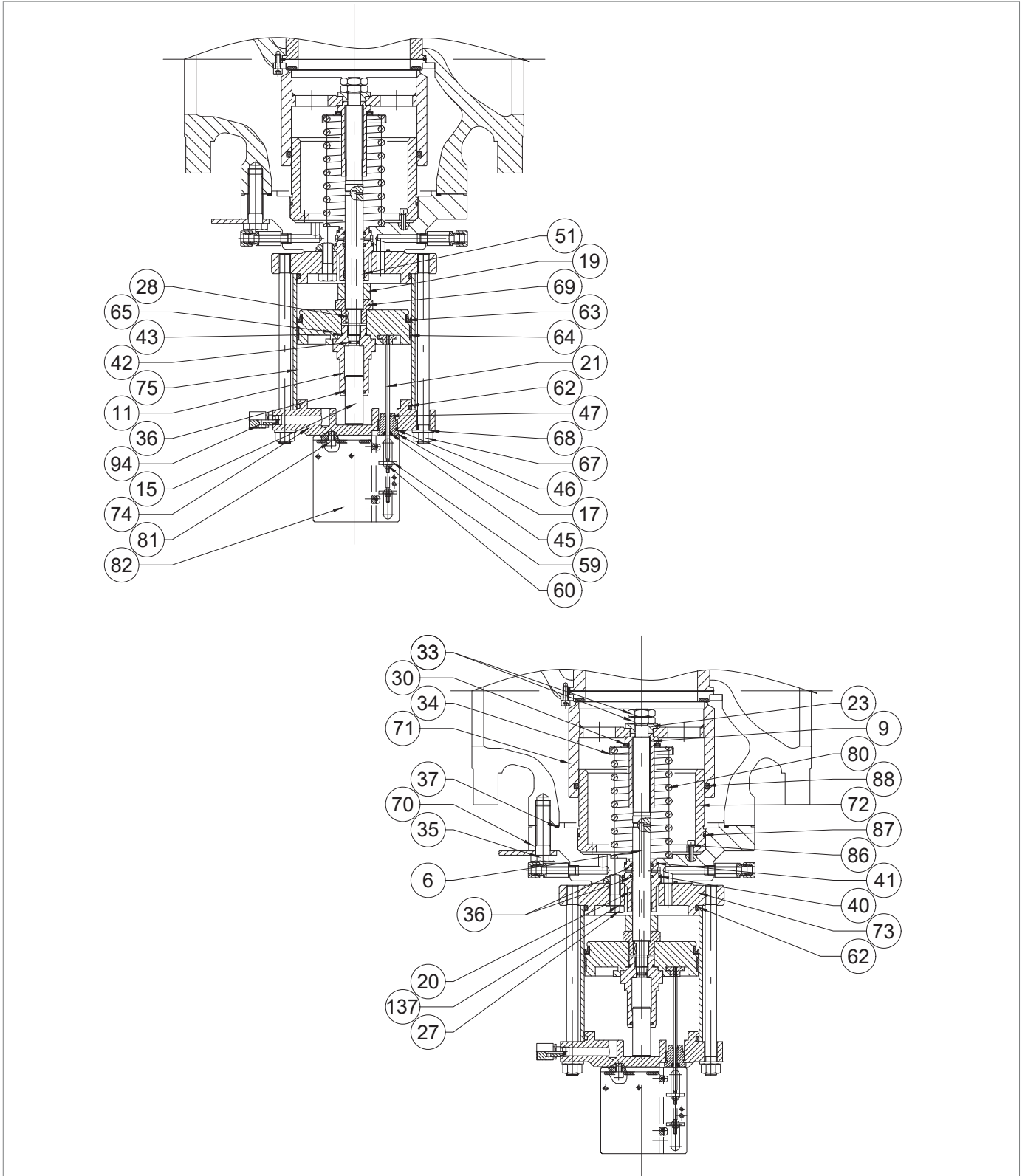

HB/97 built-in slam-shut valve

Step	Action
60	<p>Position and secure the washer (23) together with the nuts (33) according to the tightening torques:</p> <ul style="list-style-type: none"> • 4" : Tab. 9.130 • 6" : Tab. 9.134 • 8" : Tab. 9.135 • 10" : Tab. 9.136 <p>! NOTICE! Before fitting the external nut (33), apply some thread locking glue.</p>
61	<p>Fit the plating (75).</p> <p>! NOTICE! Before positioning the plating (75), clean and lubricate the inner surface with silicone grease.</p>
62	<p>Fit the upper flange (74).</p> <p>! NOTICE! The stroke indicator hole must be perpendicular to the flow and visible in the in-line installation.</p>
63	<p>Insert and fasten the nuts (67) according to the tightening torques:</p> <ul style="list-style-type: none"> • 4" : Tab. 9.130 • 6" : Tab. 9.134 • 8" : Tab. 9.135 • 10" : Tab. 9.136
64	<p>Remove the O-ring (37) from the flange (70) and replace it, taking care to lubricate it with synthetic grease.</p> <p>! NOTICE! Before inserting the replacement O-ring, clean the retaining slots with a cleaning solution.</p>
65	<p>Put the HB/97 built-in slam-shut valve back in place.</p> <p>! NOTICE! During this step, support the slam-shut device to prevent any falls.</p>
66	<p>Insert and fix the screws (35).</p> <p>! NOTICE! Tighten the screws according to the cross diagram in paragraph 9.4.2.2.</p>
67	<p>Insert the indicator rod (21).</p> <p>! NOTICE! The rod must be fitted into the slot in the piston (65).</p>
68	<p>Insert and fix the screws (17).</p>
69	<p>Put the bracket (82) in place.</p>



HB/97 built-in slam-shut valve

Step	Action
70	Insert and fix the screws (81) according to the following tightening torques: <ul style="list-style-type: none"> • 4" : Tab. 9.130 • 6" : Tab. 9.134 • 8" : Tab. 9.135 • 10" : Tab. 9.136 <div style="border: 1px solid black; padding: 5px; margin-top: 10px;">  NOTICE! Tighten the screws according to the cross diagram in paragraph 9.4.2.2. </div>
71	Fit and set the indicator washer (59) to "0".
72	Insert and fix the screws (60).
73	<div style="border: 1px solid black; padding: 5px; margin-top: 10px;">  NOTICE! To reconnect the LINE OFF 2.0 device, please refer to paragraph 9.4.14. </div>

Tab. 9.177.

 **WARNING!**

Ensure that all parts have been fitted correctly.

9.4.16 - LINE OFF 2.0 MAINTENANCE PROCEDURE

9.4.16.1 - HP2/2 BYPASS DEVICE

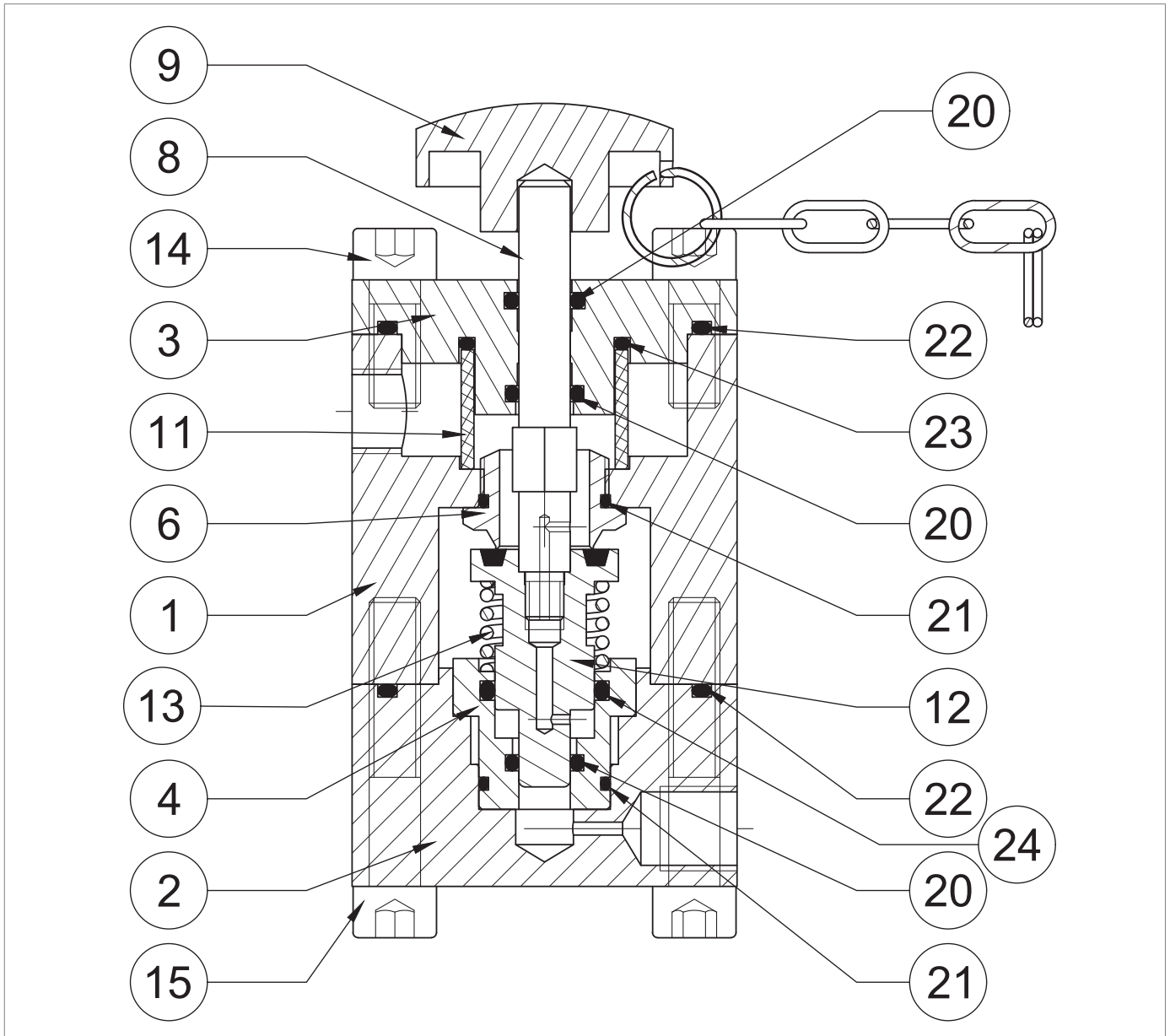







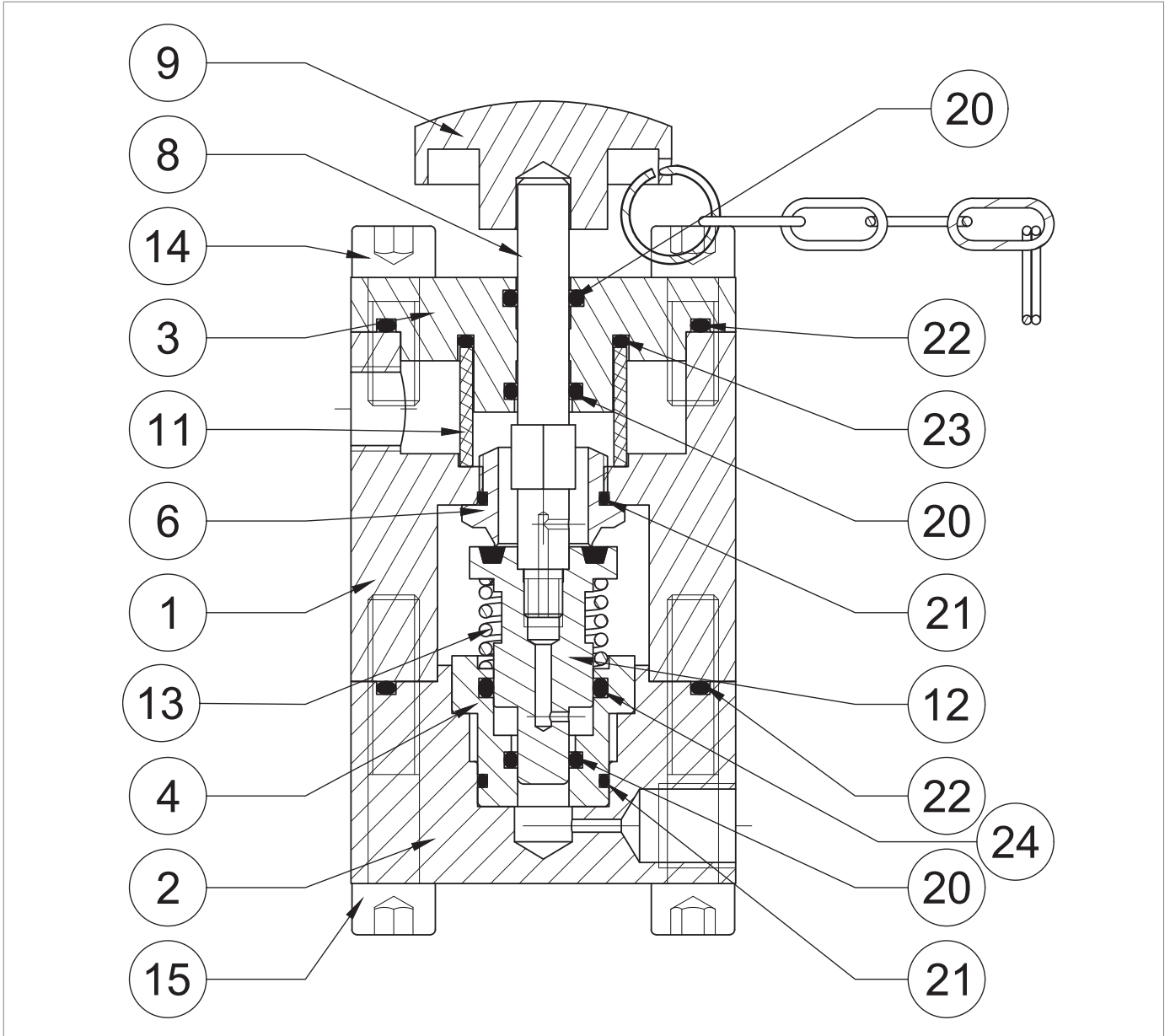





Fig. 9.101. HP2/2 bypass device

Step	Action
1	Remove the knob (9).
2	Undo and remove the screws (15).
3	Remove the cover (2) together with the bush (4), spring (13), plug (12) and stem (8).
4	Remove the bush (4), together with the spring (13), plug (12), stem (8) from the cover (2).
	Remove the O-ring (22) from the cover (2) and replace it, lubricating it with synthetic grease.
5	 NOTICE! Before inserting the replacement O-ring, clean the retaining slots with a cleaning solution.
6	Fit the plug (12) together with the stem (8).
7	Separate the stem (8) from the plug (12).
8	Replace the plug (12).
	Remove the O-rings (20, 21, 24) from the bush (4) and replace them, lubricating them with synthetic grease.
9	 NOTICE! Before inserting the replacement O-rings, clean the retaining slots with a cleaning solution.
	Undo and remove the screws (6).
10	 NOTICE! Attention do not to ruin the seat profile during this step.
	Remove the O-ring (21) from the seat (6) and replace it, lubricating it with synthetic grease.
11	 NOTICE! Before inserting the replacement O-ring, clean the retaining slots with a cleaning solution.
12	Undo and remove the screws (14).
13	Remove the flange (3).
	Remove the O-rings (22, 23) from the flange (3) and replace them, lubricating them with synthetic grease.
14	 NOTICE! Before inserting the replacement O-rings, clean the retaining slots with a cleaning solution.
	Remove the O-rings (20) from the flange (3) and replace them, lubricating them with synthetic grease.
15	 NOTICE! Before inserting the replacement O-rings, clean the retaining slots with a cleaning solution.
16	Remove and replace the filter (11).
17	Fit the flange (3).
	Insert and fix the screws (14) according to the following tightening torque:
	<ul style="list-style-type: none"> • HP2/2: Tab. 9.140
18	 NOTICE! Tighten the screws according to the cross diagram in paragraph 9.4.2.2.



HP2/2 bypass device

Step	Action
19	Fit and fix the seat (6) in the body (1). <div style="border: 1px solid black; padding: 5px;">  NOTICE! Care must be taken not to ruin the seat profile during this step. </div>
20	Fit the bush (4) in the cover (2).
21	Screw the stem (8) into the plug (12). <div style="border: 1px solid black; padding: 5px;">  NOTICE! Before fitting the stem (8), apply thread locking glue. </div>
22	Fit the spring (13).
23	Fit the plug (12) together with the stem (8) into the bush (4).
24	Fit the cover (2) together with the bush (4).
25	Insert and fix the screws (15) according to the following tightening torque: <ul style="list-style-type: none"> • HP2/2: Tab. 9.140 <div style="border: 1px solid black; padding: 5px;">  NOTICE! Tighten the screws according to the cross diagram in paragraph 9.4.2.2. </div>

Tab. 9.178.

 **WARNING!**

Ensure that all parts have been fitted correctly.

9.4.16.2 - AR100 THROTTLE VALVE

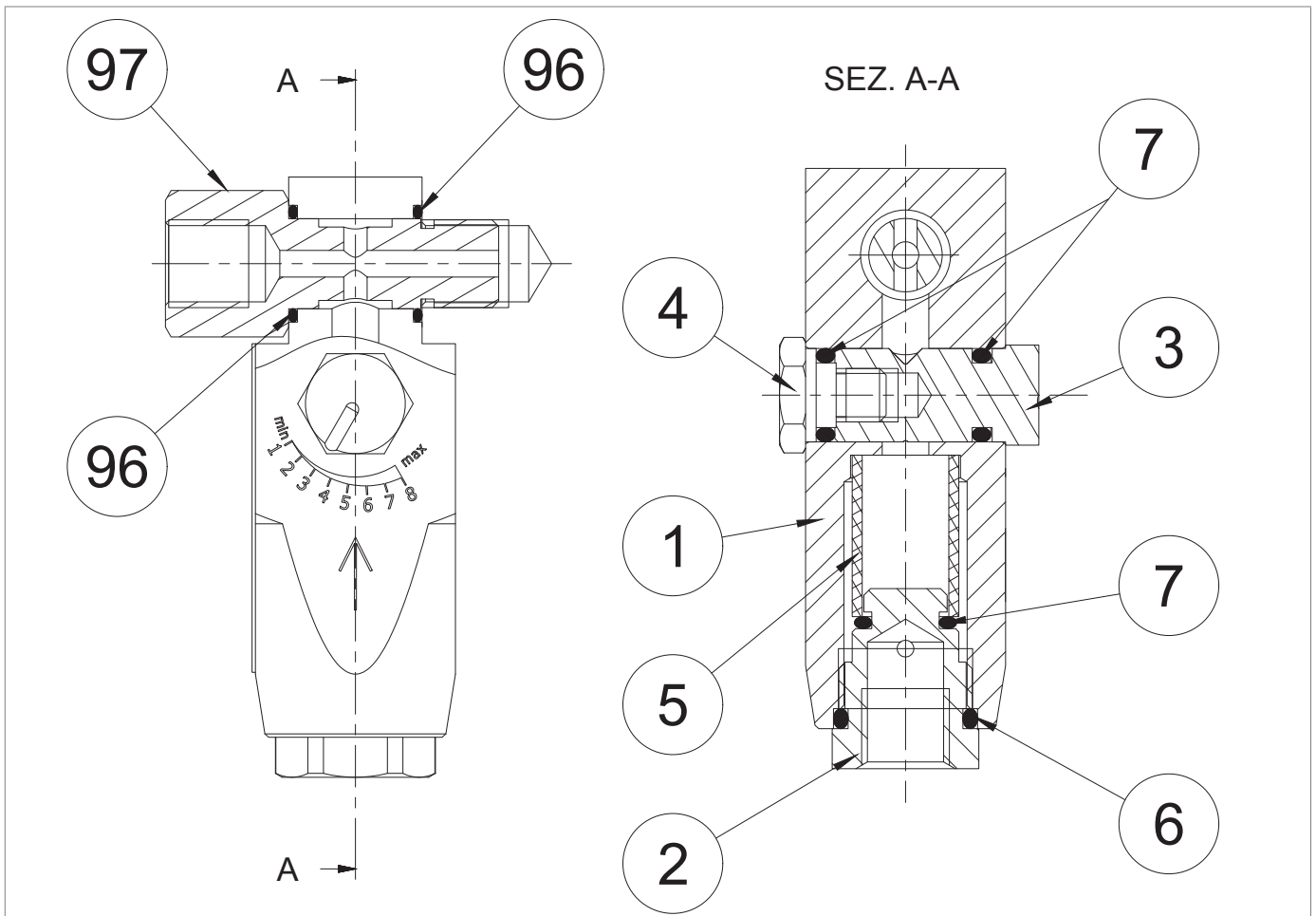

Fig. 9.102. AR100 throttle valve

Step	Action
1	Undo and remove the locking screw (97).
2	Remove the O-rings (96) from the AR100 throttle valve body (1) and replace them, lubricating them with synthetic grease. NOTICE! Before inserting the replacement O-rings, clean the retaining slots with a cleaning solution.
3	Undo and remove the locking screw (4).
4	Remove the O-ring (7) from the shut-off screw (4) and replace it, lubricating it with synthetic grease. NOTICE! Before inserting the replacement O-ring, clean the retaining slots with a cleaning solution.
5	Remove the adjusting screw (3).
6	Remove the O-ring (7) from the adjusting screw (3) and replace it, lubricating it with synthetic grease. NOTICE! Before inserting the replacement O-ring, clean the retaining slots with a cleaning solution.
7	Unscrew and remove the cap (2).
8	Remove the O-rings (6, 7) from the cap (2) and replace them, lubricating them with synthetic grease. NOTICE! Before inserting the replacement O-rings, clean the retaining slots with a cleaning solution.
9	Remove and replace the filter (5).
10	Fit and fix the cap (2) according to the following tightening torque: • AR100: Tab. 9.141 NOTICE! Take care not to damage the O-rings (6, 7).
11	Insert the adjusting screw (3), taking care not to damage the O-ring (7).
12	Fit and fix the shut-off screw (4) according to the following tightening torque: • AR100: Tab. 9.141 NOTICE! Take care not to damage the O-ring (7).
13	Insert the locking screw (97) with the valve ports in line with the AR100 throttle valve (1) body.

Tab. 9.179.

WARNING!

Ensure that all parts have been fitted correctly.

9.4.16.3 - PRESSURE REGULATOR R44/SS

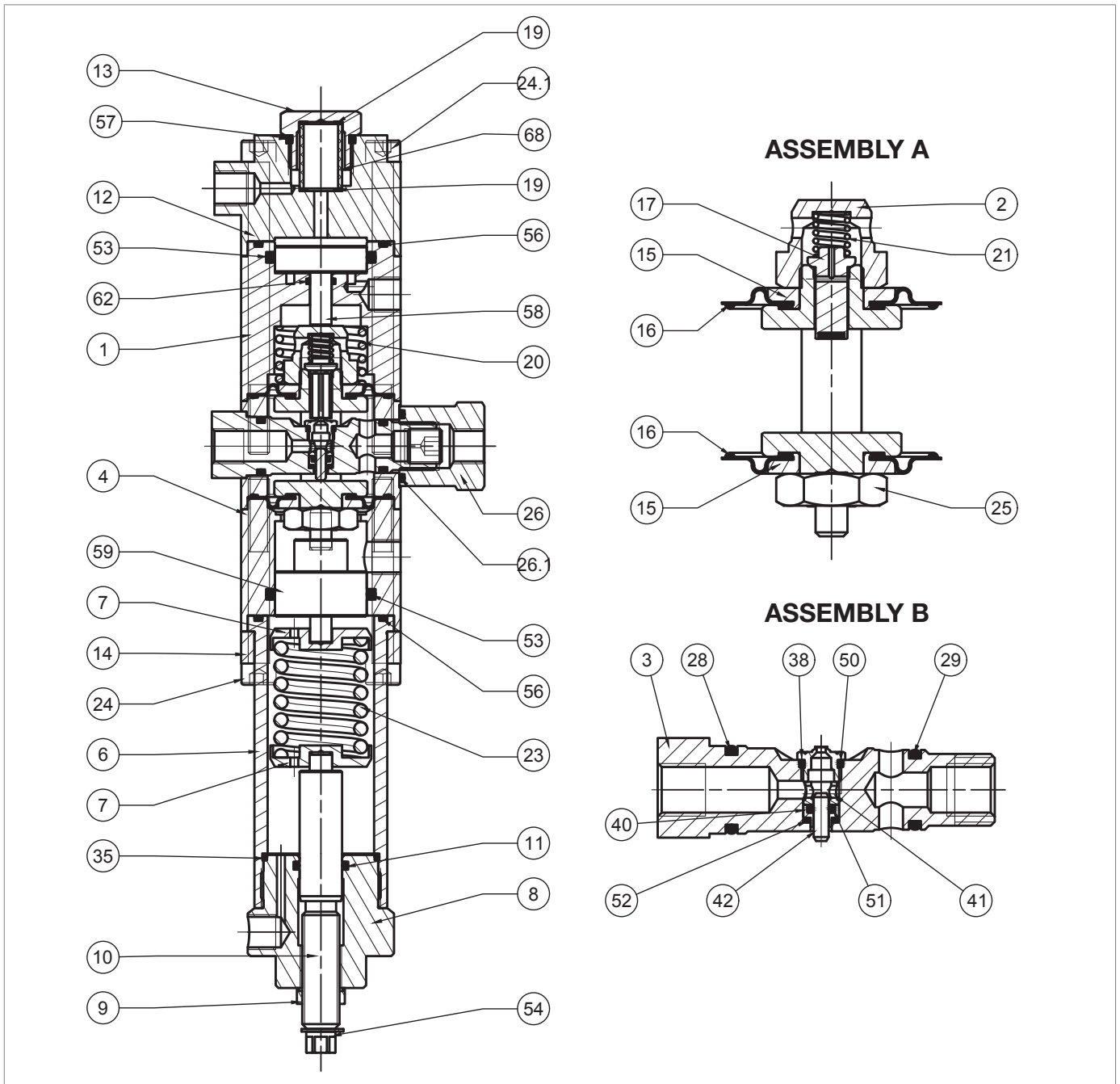
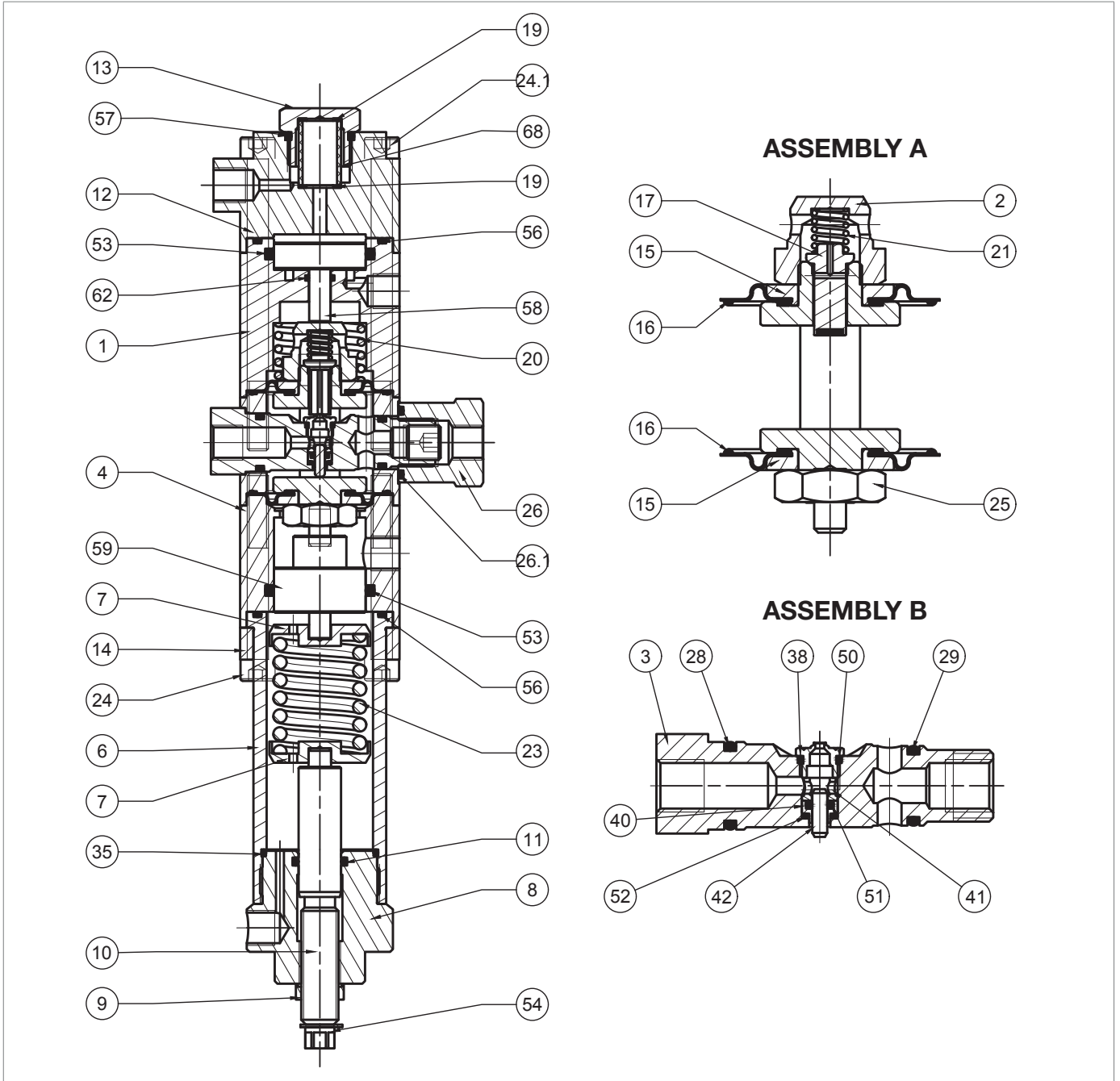









Fig. 9.103. Pressure regulator R44/SS

Step	Action
1	Remove the Seeger ring (54).
2	Unscrew the nut (9).
3	Completely release the spring (23) by turning the adjusting screw (10).
4	Unscrew and remove the cap (8).
5	Remove the spring (23) and the spring supports (7).
6	Remove the screw (10) from the cap (8) clockwise, from the inside outwards.
7	Remove the O-ring (11) from the cap (8) and replace it, lubricating it with synthetic grease. <div style="border: 1px solid black; padding: 5px;">! NOTICE! Before inserting the replacement O-ring, clean the retaining slots with a cleaning solution.</div>
8	Insert the screw (10) into the cap (8) anti-clockwise, from the outside inwards.
9	Insert the nut (9).
10	Fit the Seeger ring (54).
11	Undo the screws (24).
12	Remove the bracket (14).
13	Remove the sleeve (6).
14	Remove the O-ring (56) from the sleeve (6) and replace it, lubricating it with synthetic grease. <div style="border: 1px solid black; padding: 5px;">! NOTICE! Before inserting the replacement O-ring, clean the retaining slots with a cleaning solution.</div>
15	Remove the O-ring (35) from the sleeve (6) and replace it, lubricating it with synthetic grease. <div style="border: 1px solid black; padding: 5px;">! NOTICE! Before inserting the replacement O-ring, clean the retaining slots with a cleaning solution.</div>
16	Remove the spacer (4).
17	Take out the piston (59).
18	Remove the O-ring (53) from the spacer (4) and replace it, lubricating it with synthetic grease. <div style="border: 1px solid black; padding: 5px;">! NOTICE! Before inserting the replacement O-ring, clean the retaining slots with a cleaning solution.</div>
19	Unscrew and remove the cap (13).
20	Remove the O-ring (57) from the cap (13) and replace it, lubricating it with synthetic grease. <div style="border: 1px solid black; padding: 5px;">! NOTICE! Before inserting the replacement O-ring, clean the retaining slots with a cleaning solution.</div>
21	Remove and replace the filter (68).
22	Remove and replace the gaskets (19).
23	Undo and remove the screws (24.1).
24	Remove the cover (12).
25	Remove the cover (1).
26	Take out the piston (58).





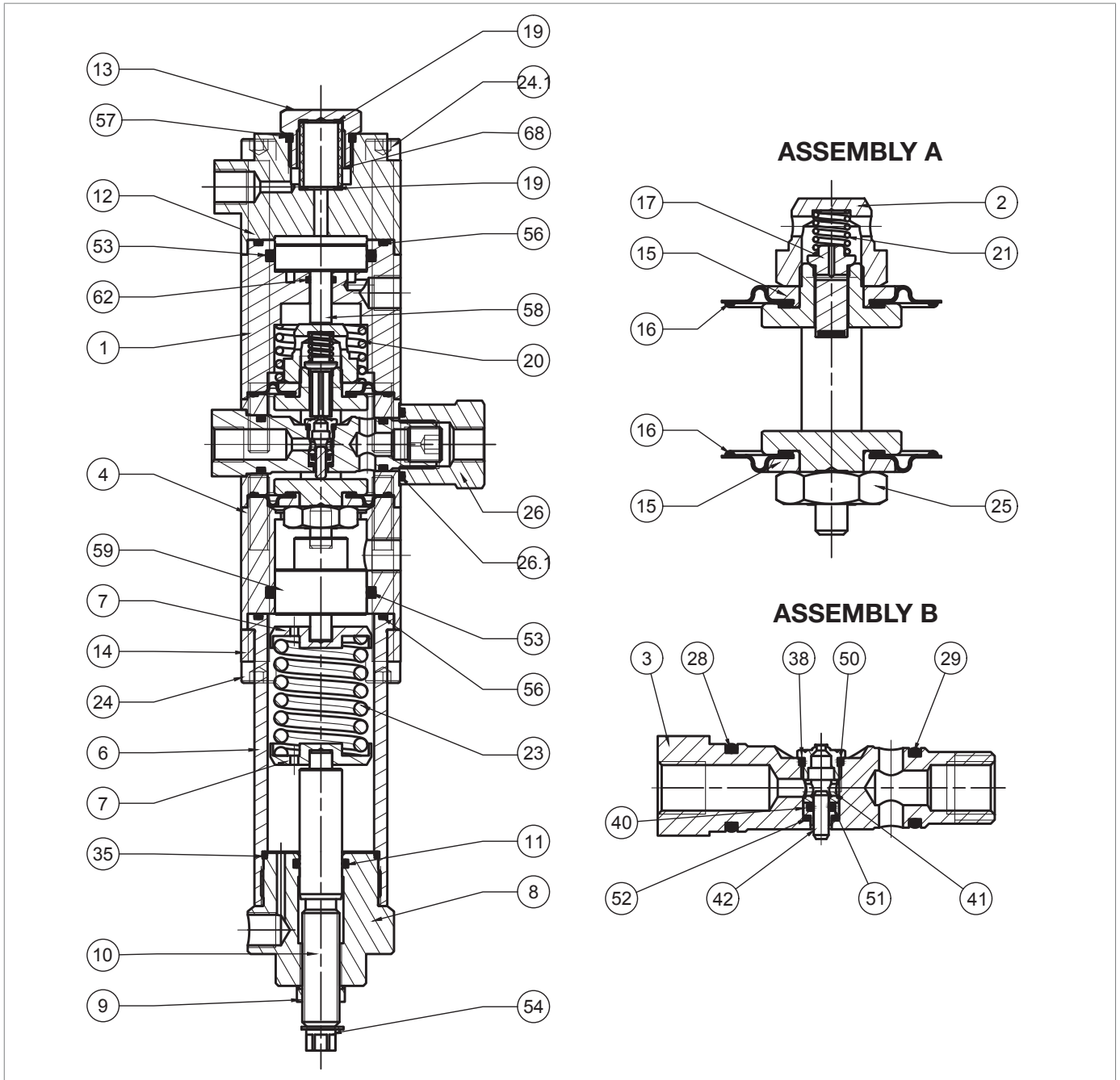

Pressure regulator R44/SS

Step	Action
27	Remove the O-ring (56) from the cover (1) and replace it, lubricating it with synthetic grease. <div style="border: 1px solid black; padding: 2px;">  NOTICE! Before inserting the replacement O-ring, clean the retaining slots with a cleaning solution. </div>
28	Remove the O-rings (53, 62) from the cover (1) and replace them, lubricating them with synthetic grease. <div style="border: 1px solid black; padding: 2px;">  NOTICE! Before inserting the replacement O-rings, clean the retaining slots with a cleaning solution. </div>
29	Remove the spring (20).
30	Unscrew the nut (26).
31	Remove the O-ring (26.1) from the nut (26) and replace it, lubricating it with synthetic grease. <div style="border: 1px solid black; padding: 2px;">  NOTICE! Before inserting the replacement O-ring, clean the retaining slots with a cleaning solution. </div>
32	Pull out the "B" (valve) assembly.
33	Unscrew the valve seat (38). <div style="border: 1px solid black; padding: 2px;">  NOTICE! Take care not to damage the surfaces. </div>
34	Remove the O-ring (50) from the valve seat (38) and replace it, lubricating it with synthetic grease. <div style="border: 1px solid black; padding: 2px;">  NOTICE! Before inserting the replacement O-ring, clean the retaining slots with a cleaning solution. </div>
35	Remove the bush (41).
36	Remove the balancing piston (42).
37	Take out the piston guide (40).
38	Remove the O-ring (51) from the piston guide (40) and replace it, lubricating it with synthetic grease. <div style="border: 1px solid black; padding: 2px;">  NOTICE! Before inserting the replacement O-ring, clean the retaining slots with a cleaning solution. </div>
39	Remove the O-ring (52) from the valve seat (3) and replace it, lubricating it with synthetic grease. <div style="border: 1px solid black; padding: 2px;">  NOTICE! Before inserting the replacement O-ring, clean the retaining slots with a cleaning solution. </div>
40	Remove the O-rings (28, 29) from the valve seat (3) and replace them, lubricating them with synthetic grease. <div style="border: 1px solid black; padding: 2px;">  NOTICE! Before inserting the replacement O-rings, clean the retaining slots with a cleaning solution. </div>
41	Fit the piston guide (40) and balancing piston (42).
42	Insert the bush (41) into the pilot seat (3) so that the wider stop rests on the O-ring (51).



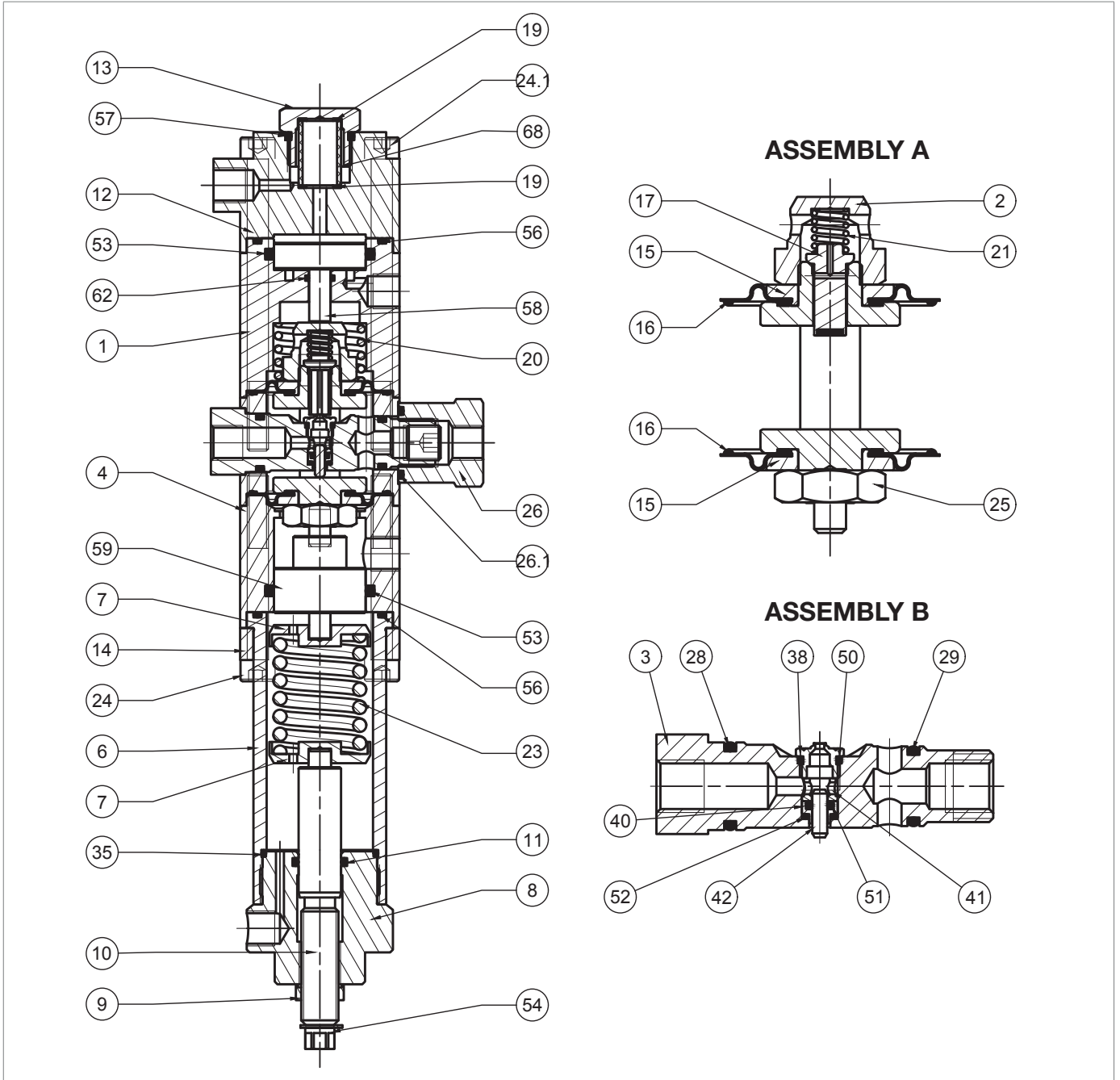

Pressure regulator R44/SS

Step	Action
43	Insert and fix the valve seat (38). <div style="border: 1px solid black; padding: 5px;">  NOTICE! Take care not to damage the valve seat profile (38) and the O-ring (50). </div>
44	Remove assembly "A" (plug) from the valve body (4).
45	Unscrew and remove the pilot nut (2).
46	Remove the spring (21).
47	Remove and replace the plug (17).
48	Remove the upper protection disc (15).
49	Remove and replace the upper diaphragm (16), lubricating the lanyards with synthetic grease. <div style="border: 1px solid black; padding: 5px;">  NOTICE! Before inserting the replacement diaphragm, clean the retaining slots with a cleaning solution. </div>
50	Unscrew and remove the nut (25).
51	Remove the lower protection disc (15).
52	Remove and replace the lower diaphragm (16), lubricating the lanyards with synthetic grease. <div style="border: 1px solid black; padding: 5px;">  NOTICE! Before inserting the replacement diaphragm, clean the retaining slots with a cleaning solution. </div>
53	Fit the lower protection disc (15).
54	Insert and fix the screws (25) according to the following tightening torque: <ul style="list-style-type: none"> • R44/SS: Tab. 9.142
55	Fit the upper protection disc (15).
56	Fit the plug (17).
57	Fit the spring (21).
58	Insert and fix the pilot nut (2) according to the following tightening torque: <ul style="list-style-type: none"> • R44/SS: Tab. 9.142
59	Insert assembly "A" (plug) from top to bottom into the valve body (4). <div style="border: 1px solid black; padding: 5px;">  NOTICE! <ul style="list-style-type: none"> • Take care not to damage the diaphragms (16) during this step; • The marking on the lower section of the headframe (5) must be parallel to the axis of the hole for inserting the seat (3) into the valve body (4). </div>
60	Insert assembly "B" (valve) into the valve body (4). <div style="border: 1px solid black; padding: 5px;">  NOTICE! <ul style="list-style-type: none"> • Insert the assembly with the valve seat (38) facing upwards; • Take care not to damage the O-rings (28, 29) and the valve seat (38). </div>
61	Screw in the nut (26) according to the following tightening torque: <ul style="list-style-type: none"> • R44/SS: Tab. 9.142
62	Fit the spring (20).
63	Insert the piston (58) into the cover (1).
64	Fit the covers (1 and 12).



Pressure regulator R44/SS

Step	Action
65	Insert and fix the screws (24.1) according to the following tightening torque: <ul style="list-style-type: none"> R44/SS: Tab. 9.142 <div style="border: 1px solid black; padding: 5px;">  NOTICE! Tighten the screws according to the cross diagram in paragraph 9.4.2.2. </div>
66	Fit the gaskets (19) and the filter (68).
67	Position and secure the nut (13).
68	Fit the piston (59) into the spacer (4).
69	Fit the sleeve (6).
70	Put the bracket (14) in place.
71	Insert and fix the screws (24) according to the following tightening torque: <ul style="list-style-type: none"> R44/SS: Tab. 9.142 <div style="border: 1px solid black; padding: 5px;">  NOTICE! Tighten the screws according to the cross diagram in paragraph 9.4.2.2. </div>
72	Insert the spring (23) together with the spring supports (7). <div style="border: 1px solid black; padding: 5px;">  NOTICE! Make sure that the piston pin (59) is inside the spring support (7). </div>
73	Fit and secure the cap (8) to the sleeve (6).

Tab. 9.180.

 **WARNING!**
Ensure that all parts have been fitted correctly.

9.4.16.4 - SAFETY VALVE VS/FI FOR LINE OFF 2.0

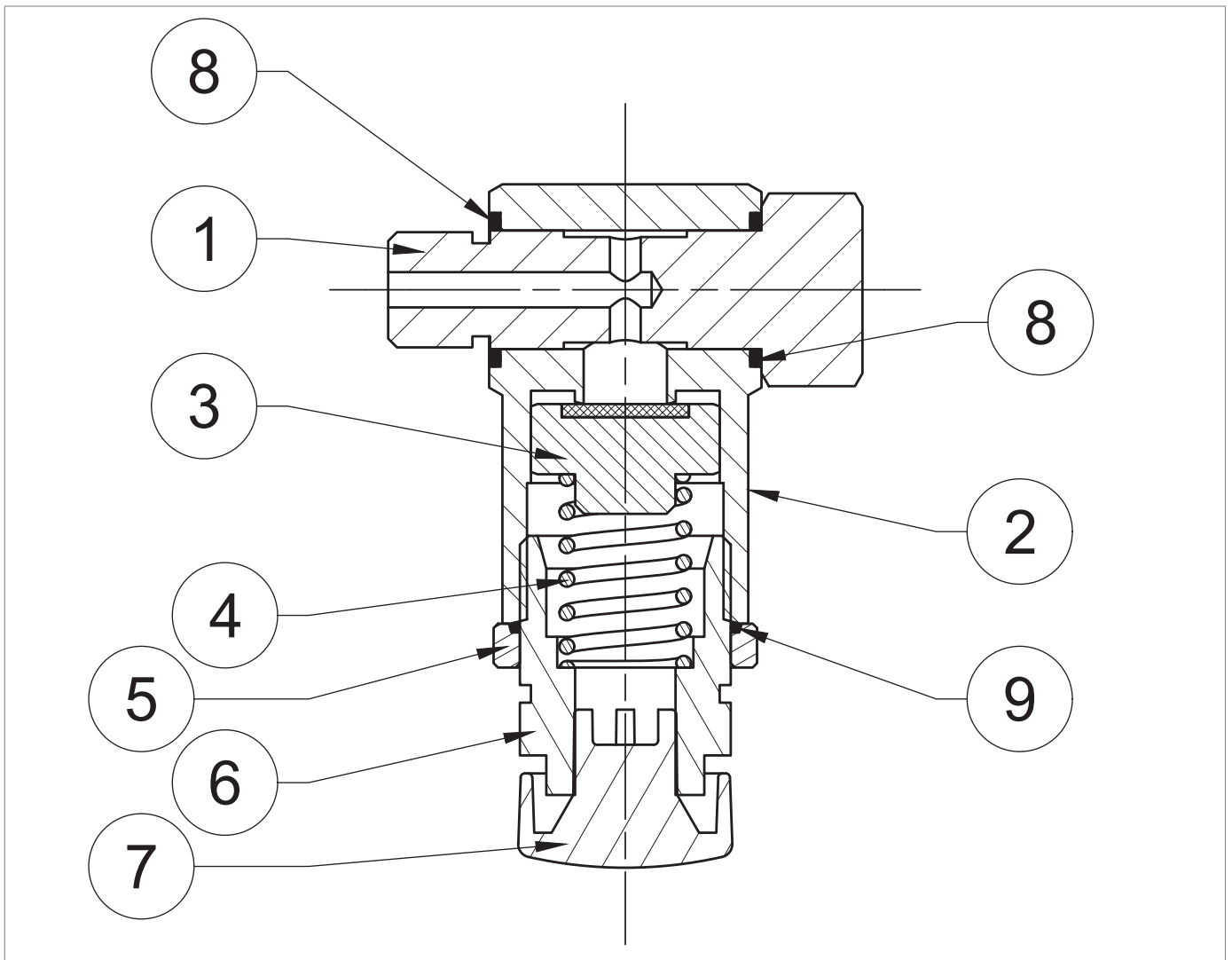



Fig. 9.104. Safety valve VS/FI for LINE OFF 2.0

Step	Action
1	Pull out the locking screw (1).
2	Remove the O-rings (8) from the body (2) and replace them, lubricating them with synthetic grease. <div style="border: 1px solid black; padding: 2px;">  NOTICE! Before inserting the replacement O-ring, clean the retaining slots with a cleaning solution. </div>
3	Remove the vent plug (7) and make sure that it is not obstructed by any dirt.
4	Loosen the ring nut (5).
5	Unscrew and remove the cap (6).
6	Remove the O-ring (9) from the ring nut (5) and replace it, lubricating it with synthetic grease. <div style="border: 1px solid black; padding: 2px;">  NOTICE! Before inserting the replacement O-ring, clean the retaining slots with a cleaning solution. </div>
7	Remove the spring (4).
8	Remove and replace the plug (3).
9	Insert the plug (3) and the spring (4).
10	Insert and screw in the cap (6).
11	Fit the vent cap (7).
12	Insert the locking screw (1).

Tab. 9.181.

 **WARNING!**

Ensure that all parts have been fitted correctly.

9.4.16.5 - PRESSURE SWITCHES MOD. 100

 **NOTICE!**

For more information, please refer to Paragraph 9.4.13.

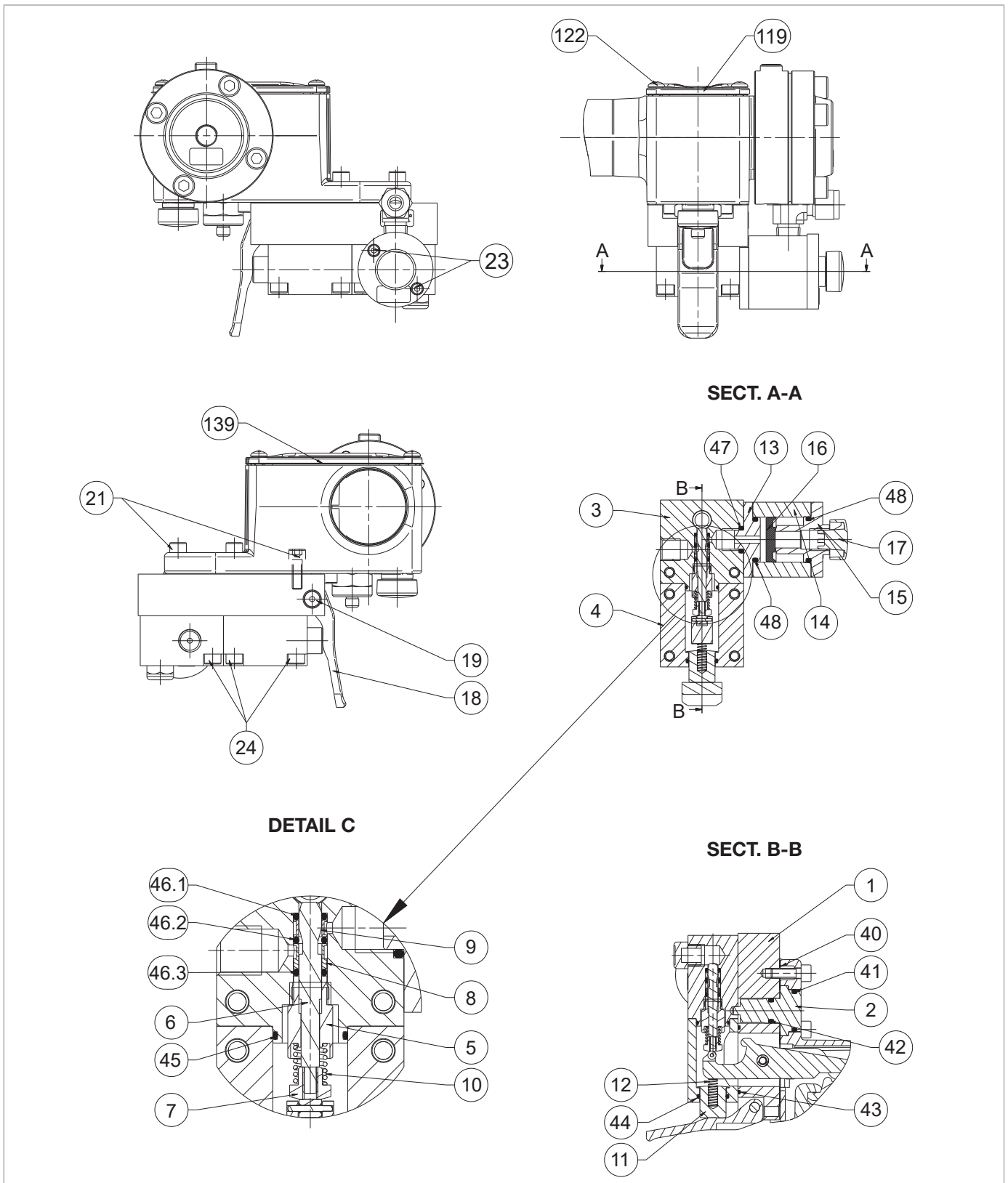







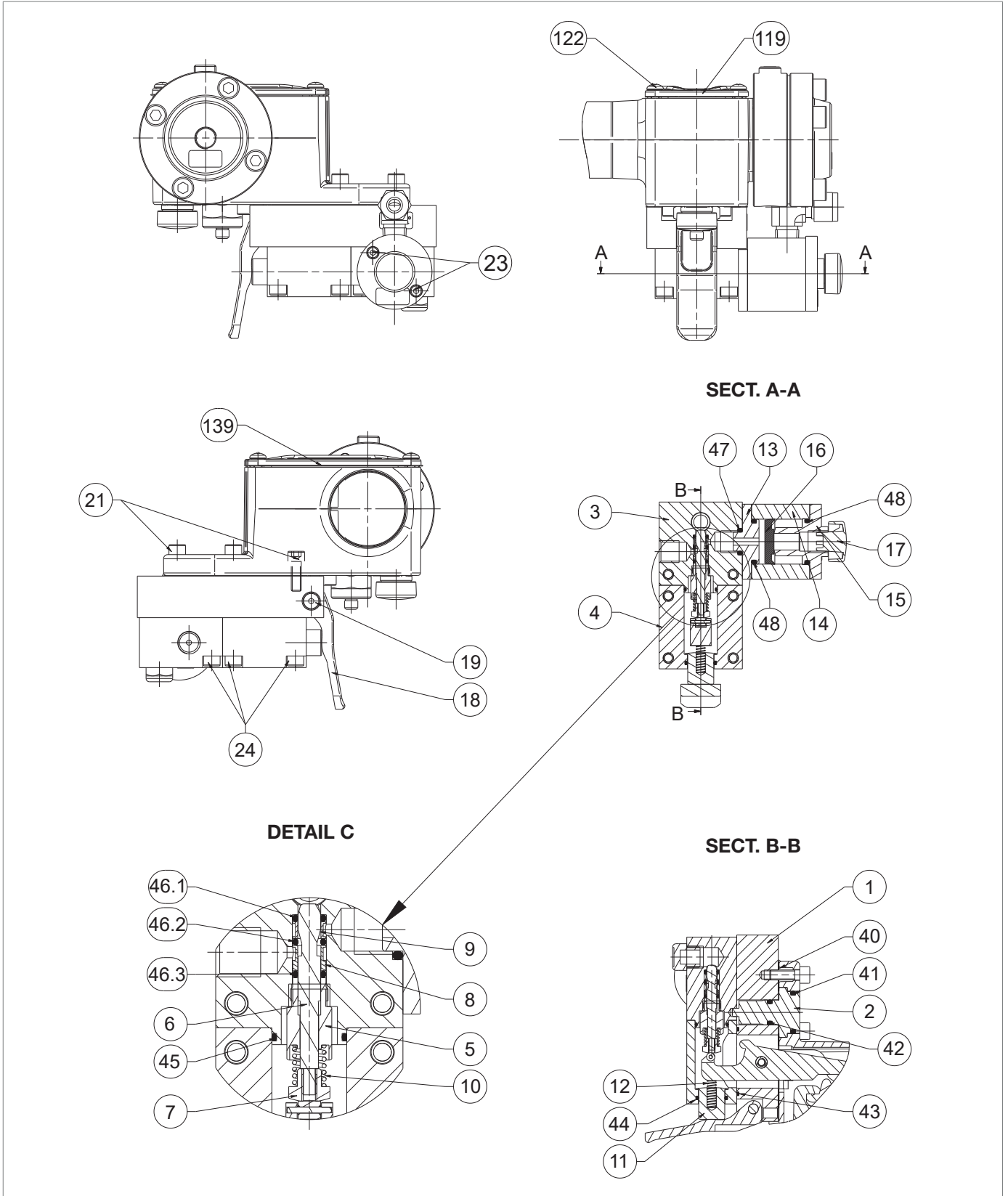

Fig. 9.105. Valve 3/2

Step	Action
1	 NOTICE! Make sure the block is in the OFF state
2	Undo and remove the screws (122) of the pressure switch cover (119).
3	Remove the pressure switch cover (119) together with the gasket (139).
4	Turn the device upside down.
5	Undo and remove the screw (19) and the lever (18).
6	Undo and remove the screws (23).
7	Remove the quick discharge assembly (13, 14, 15, 17).
8	Remove the O-ring (47) from the valve body (3) and lubricate it with synthetic grease.  NOTICE! Before inserting the replacement O-ring, clean the retaining slots with a cleaning solution.
9	Remove the locking flange (15).
10	Remove the O-ring (48) from the shut-off flange (15) and replace it, lubricating it with synthetic grease.  NOTICE! Before inserting the replacement O-ring, clean the retaining slots with a cleaning solution.
11	Remove and replace the gasket (16), lubricating it with synthetic grease.  NOTICE! Orient the lip of the seal (16) towards the cover (15).
12	Remove the intermediate flange (13).
13	Remove the O-ring (48) from the intermediate flange (13) and replace it, lubricating it with synthetic grease.  NOTICE! Before inserting the replacement O-ring, clean the retaining slots with a cleaning solution.
14	Undo and remove the screws (24).
15	Lift the valve body (3) together with the valve cover (4).
16	Separate the valve body (3) from the valve cover (4).
17	Remove the O-ring (45) from the valve cover (3) and lubricate it with synthetic grease.  NOTICE! Before inserting the replacement O-ring, clean the retaining slots with a cleaning solution.
18	Pull out the button (11) together with the spring (12),
19	Remove the O-ring (44) from the valve cover (4) and lubricate it with synthetic grease.  NOTICE! Before inserting the replacement O-ring, clean the retaining slots with a cleaning solution.
20	Fit the button (11) together with the spring (12).
21	Unscrew and remove the stem assembly (5, 6, 7, 8, 9, 10).



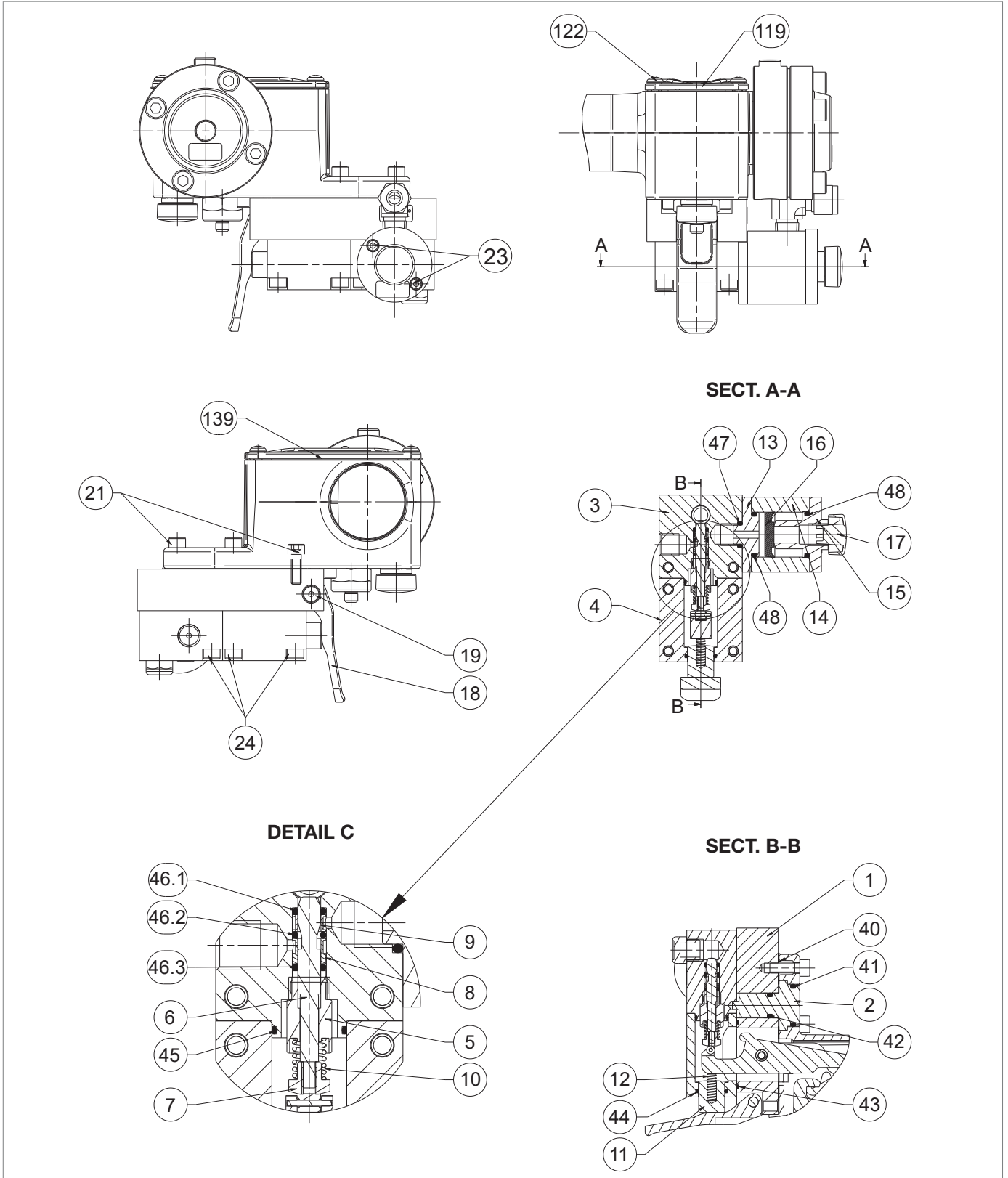

Valve 3/2

Step	Action
22	Remove the O-ring (46.3) and the bush (8).
23	Remove the O-ring (46.2) and the bush (9).
24	Remove the O-ring (46.1).
25	<p>Replace the O-rings (46.1, 46.2 and 46.3) and lubricate them with synthetic grease.</p> <div style="border: 1px solid black; padding: 5px;"> <p>! NOTICE! Before inserting the replacement O-rings, clean the retaining slots with a cleaning solution.</p> </div>
26	<p>Insert the O-ring (46.1) and the perforated bushing (9).</p> <div style="border: 1px solid black; padding: 5px;"> <p>! NOTICE! Use the equipment (G) of Tab. 7.62.</p> </div>
27	<p>Insert the O-ring (46.2) and the perforated bush (8).</p> <div style="border: 1px solid black; padding: 5px;"> <p>! NOTICE!</p> <ul style="list-style-type: none"> • Use the equipment (G) of Tab. 7.62. • Align the bush (8) as shown in detail (C) </div>
28	<p>Insert the O-ring (46.3).</p> <div style="border: 1px solid black; padding: 5px;"> <p>! NOTICE! Use the equipment (G) of Tab. 7.62.</p> </div>
29	Insert and press the equipment (G) together with the O-rings (46.1, 46.2, 46.3) and the perforated bushings (8, 9) into the valve body (3).
30	Pull out the equipment (G).
31	Insert and screw the stem assembly (5, 6, 7, 8, 9, 10).
32	<p>Remove the O-ring (43) from the valve bracket (1) and replace it, lubricating it with synthetic grease.</p> <div style="border: 1px solid black; padding: 5px;"> <p>! NOTICE! Before inserting the replacement O-ring, clean the retaining slots with a cleaning solution.</p> </div>
33	Turn the device upside down.
34	Undo and remove the outer screws (21).
35	Undo and remove the inner screws (21).
36	Lift the pressure switch.
37	Remove the centring pin (2).
38	<p>Remove the O-rings (41, 42) from the centring pin (2) and replace them, lubricating them with synthetic grease.</p> <div style="border: 1px solid black; padding: 5px;"> <p>! NOTICE! Before inserting the replacement O-rings, clean the retaining slots with a cleaning solution.</p> </div>
39	Remove and replace the gasket (40).
40	Fit the centring pin (2) on the valve bracket (1).
41	Assemble the pressure switch to the valve bracket (1).
42	Insert and fix the screws (21).
43	Insert and fix the internal screws (21).
44	Turn the device upside down.



Valve 3/2

Step	Action
45	Insert the valve cover (4) so that the spring (12) rests on the lever of the pressure switch.  NOTICE! Keep the valve cover (4) tilted for easier assembly.
46	Push and tilt the valve cover upwards (4).
47	Insert the valve body (3) together with the stem assembly (5, 6, 7, 8, 9, 10) into the valve cover (4).  NOTICE! The valve body (3) must be centred with the centring pin (2).
48	Fasten the screws (24) of the valve body (3).
49	Fasten the screws (24) of the valve cover (4).
50	Fit the lever (18).
51	Insert and fix the screws (19).
52	Insert the flange (15) into the cylinder (14).
53	Insert the gasket (16) into the cylinder (14) with the flat side facing upwards.
54	Insert the flange (13) into the cylinder (14).
55	Insert the screws (23).
56	Fit the quick discharge assembly (13, 14, 15, 17) into the valve body (3).
57	Fix the screws (23).
58	Fit the cover (119) together with the gasket (139).
59	Insert and fix the screws (122) of the pressure switch.

Tab. 9.182.

 **WARNING!**

Ensure that all parts have been fitted correctly.

9.5 - LINE OFF 2.0 RECONNECTION

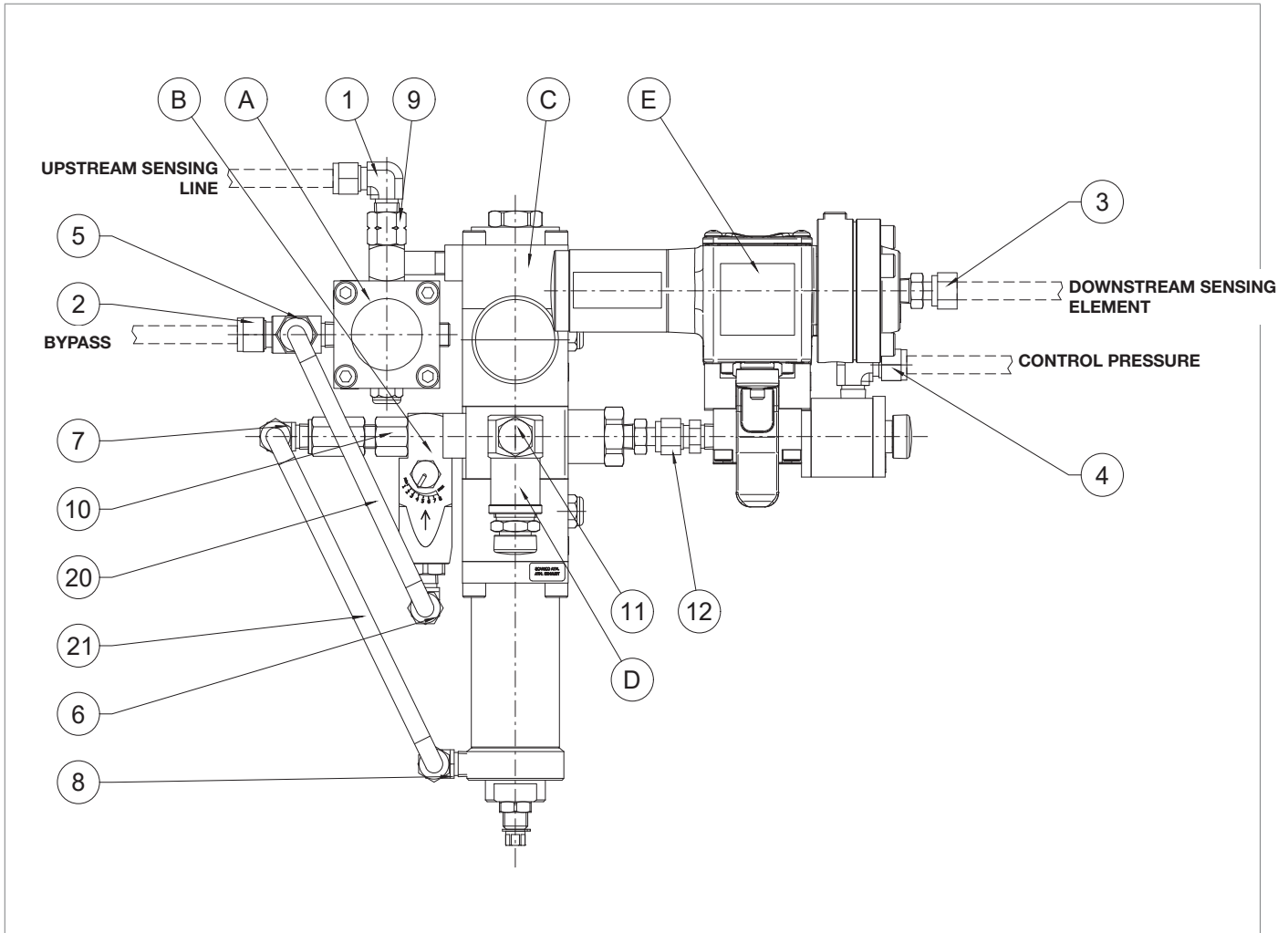

Fig. 9.106. LINE OFF 2.0

When maintenance is complete, reconnect the LINE OFF 2.0 device as shown in Tab. 9.183 (see Fig. 9.106):

Step	Action
1	Remove assembly "E" (valve 3/2 and control device) from assembly "C" (regulator R44/SS) together with the fitting (12).
2	Remove assembly "D" (safety valve VS/FI) together with the screw (11).
3	Remove assembly "B" (throttle valve AR100) together with the fitting (10).
4	Remove assembly "A" (bypass device HP2/2) together with the fitting (9).
5	Reconnect the pipe (21) together with the fittings (7, 8).
6	Reconnect the pipe (20) together with the fittings (5, 6).
7	Insert and tighten the fixing screw to put the LINE OFF 2.0 in place.
8	Reconnect the pipes together with the fittings (1, 2, 3, 4).

Tab. 9.183.

9.5.1 - PROCEDURE FOR RECOMMISSIONING AFTER MAINTENANCE

NOTICE!

For the recommissioning procedure, refer to the relevant paragraph.

PAGE INTENTIONALLY LEFT BLANK

10 - TROUBLESHOOTING

Listed below are the cases (causes and tripping) that could occur in the form of malfunctions of various kinds over time. These situations depend on the conditions of the gas as well as on the natural ageing and wear of the materials.

10.1 - GENERAL WARNINGS

HAZARD!

Maintenance work must be carried out by qualified personnel:

- trained in workplace safety also based on the regulations in force in the place of installation of the work equipment;
- qualified and authorised to carry out activities related to the equipment.

WARNING!







Shall not be held liable for any damage to people and property due to PIETRO FIORENTINI S.p.A. actions:

- other than those described;
- performed according to methods other than those specified;
- carried out by unsuitable personnel.

NOTICE!

If an operating fault occurs and qualified personnel are not available for the specific service, call the PIETRO FIORENTINI S.p.A. Authorised Assistance Centre

10.2 - OPERATOR QUALIFICATION SPECIFICATION

Commissioning	
Operator qualification	<ul style="list-style-type: none"> • Mechanical maintenance technician; • Electrical maintenance technician; • Installer; • User technician.
PPE required	<div style="display: flex; align-items: center; gap: 5px;">      </div> <div style="background-color: #f4a460; padding: 5px; margin-top: 5px;">  WARNING! </div> <p>The PPE listed in this table is related to the risk associated with the equipment. For the required PPE to protect against risks associated with the workplace, installation or operating conditions, please refer to:</p> <ul style="list-style-type: none"> • the regulations in force in the country of installation; • <u>any information provided by the Safety Manager at the installation facility.</u>
Equipment required	Please refer to the chapter “7 - Commissioning/maintenance equipment”.

Tab. 10.184.

10.3 - TROUBLESHOOTING PROCEDURES

For proper troubleshooting, proceed as follows:

- close the upstream and downstream shut-off valves;
- refer to the troubleshooting tables listed below.

10.4 - TROUBLESHOOTING TABLES

NOTICE!

See chapter “9 - Maintenance and functional checks” for pictures of the regulator REVAL 182 and its accessories.

10.4.1 - TROUBLESHOOTING REVAL 182 REGULATOR

WARNING!

If the built-in slam-shut valve has tripped, close the upstream and downstream shut-off valves (V1 and V2) of the line before any operation and relieve the pressure.

Failure	Device	Possible causes	Intervention
Anomalies of operation.	REGULATOR	Dirty or worn reinforced gasket (7)	Clean and replace if needed
		O-ring (35) friction	Lubricate and replace if necessary
		Stem guide O-ring (36) frictions	Lubricate and replace if necessary
		I/DWR (52) frictions	Lubricate and replace if necessary
		I/DWR (51) friction	Lubricate and replace if necessary
		Breakage of the diaphragm (50)	Replace
		SG out of class due to dirty or worn reinforced gasket (7)	Clean and replace if needed
	PRE - REGULATOR R31/A	Reinforced gasket (9) dirty or damaged	Clean and replace if needed
		Plug guide ring (8) worn	Replace
	201/A SERIES PILOT	Dirty or worn plug (17)	Clean and replace if needed
		Friction of the diaphragm carrier assembly (16)	Centre the diaphragm carrier assembly on the shaft
		Worn diaphragms (16)	Replace
		Spring (22) collapsed or out of level	Reposition and replace if necessary
		AC out of class due to unsuitable spring (22)	Replace
		SG out of class due to dirty or worn plug (17)	Clean and replace if needed
		Worn main diaphragm (42)	Replace
	PRE - REGULATOR R14/A	Dirty or worn plug (5)	Clean and replace if needed
Plug guide ring (8) worn		Replace	

Failure	Device	Possible causes	Intervention
Anomalies of operation.	204/A SERIES PILOT	Dirty or worn plug (17)	Clean and replace if needed
		Friction of the diaphragm carrier assembly (16)	Align the support hole diaphragms (5) with the seat valve (3)
		Worn diaphragms (16)	Replace
		Spring (22) collapsed or out of level	Reposition and replace if necessary
		AC out of class due to unsuitable spring (22)	Replace
		SG out of class due to dirty or worn plug (17)	Clean and replace if needed
Failed sealing or zero flow rate	REGULATOR	Reinforced gasket (8) dirty or worn	Clean and replace if needed
		O-ring (35) not sealing	Clean and replace if needed
		Balancing piston O-ring (36) not sealing	Clean and replace if needed
		O-ring (42) not sealing	Clean and replace if needed
		O-ring (43) not sealing	Clean and replace if needed
	PRE - REGULATOR R31/A	O-ring (18) not sealing	Clean and replace if needed
		O-ring (20) not sealing	Clean and replace if needed
		Diaphragm (10) damaged	Replace
	201/A SERIES PILOT	Dirty or worn plug (17)	Clean and replace if needed
	PRE - REGULATOR R14/A	O-ring (17) not sealing	Clean and replace if needed
		O-ring (18) not sealing	Clean and replace if needed
		O-ring (20) not sealing	Clean and replace if needed
		Diaphragm (10) damaged	Replace
	204/A SERIES PILOT	Upper diaphragm (19) damaged	Replace
Dirty or worn plug (17)		Clean and replace if needed	

Failure	Device	Possible causes	Intervention
Downstream pressure increases in delivery	REGULATOR	Reinforced gasket (7) damaged	Replace
		Ice between reinforced gasket (7) and plug (5)	Increase the gas inlet temperature of the regulator
		Soiling between reinforced gasket (7) and plug (5)	Clean and check gas filtration
		Plug (5) locked	Clean and check the movements
		Tightening screws (29) of the diaphragm assembly (50)	Tighten properly
		Transfer hole (21) obstructed	Clean
		Plug guide O-ring (35) damaged	Replace
		Stem guide O-ring (36) frictions	Lubricate and replace if necessary
		I/DWR (52) frictions	Lubricate and replace if necessary
		I/DWR (51) friction	Lubricate and replace if necessary
		Spring (54) collapsed	Replace
	PRE - REGULATOR R31/A	Plug (5) damaged	Replace
	201/A SERIES PILOT	Plug (17) damaged	Replace
		Assembly of diaphragm holder (16) and plug (17) locked in open position	Check and clean if necessary
		Plug spring (21) collapsed	Replace
		Downstream sensing line obstructed	Clean
	PRE - REGULATOR R14/A	Plug (5) damaged	Replace
	204/A SERIES PILOTS	Plug (17) damaged	Replace
		Diaphragm holder (16) and plug (17) assembly locked in open position	Check and clean if necessary
		Plug spring (21) collapsed	Replace
Downstream sensing line obstructed		Clean	

Failure	Device	Possible causes	Intervention
Downstream pressure decreases in delivery	REGULATOR	No upstream pressure	Check line filter cartridges for clogging
		Plug (5) locked	Clean and check the movements
		Dirty O-ring (35)	Clean and replace if needed
		Stem guide (20) O-ring frictions (36)	Lubricate and replace if necessary
		I/DWR (52) frictions	Lubricate and replace if necessary
		I/DWR (51) friction	Lubricate and replace if necessary
		Ice formation	Increase the gas inlet temperature of the regulator
		Diaphragm (50) damaged	Replace
		Stem guide (20) loose	Tighten
	PRE - REGULATOR R31/A	Diaphragm (10) damaged	Replace
	201/A SERIES PILOT	Plug (17) damaged	Replace
		Diaphragm holder assembly (16) and plug (17) locked in shut-off position	Check and clean if necessary
		Downstream sensing line obstructed	Clean
	PRE - REGULATOR R14/A	Filter (13) clogged	Replace
		Reinforced gasket (9) damaged	Replace
		Diaphragm (10) damaged	Replace
		Plug (5) locked in in closing	Clean and lubricate
		Plug (5) obstructed	Clean
	204/A SERIES PILOTS	Plug (17) locked in shut-off position	Clean and lubricate
		Diaphragms (16) damaged	Replace
		Diaphragm holder (16) and plug (17) assembly locked in open position	Check and clean if necessary
		Valve seat (3) clogged	Clean
		Spring (22) collapsed	Replace

Tab. 10.185.

10.4.2 - TROUBLESHOOTING OF THE DB/182 SILENCER

Failure	Device	Possible causes	Intervention
Increase in noise	DB/182 SILENCER	Breakage of the external basket (64)	Replace
Failed sealing Zero flow rate	DB/182 SILENCER	Failed sealing of the O-ring (39)	Clean and replace if needed
		Failed sealing of the O-ring (84)	Clean and replace if needed

Tab. 10.186.

10.4.3 - TROUBLESHOOTING OF MONITOR PM/182

Failure	Device	Possible causes	Intervention
Abnormalities of operation	PRE-REGULATOR R14/A	Dirty or worn plug (5)	Clean and replace if needed
		Plug guide ring (8) worn	Replace
	204/A SERIES PILOTS	Dirty or worn plug (17)	Clean and replace if needed
		Diaphragm holder unit friction (16)	Align the hole of the diaphragm support (5) with the valve seat (3)
		Worn diaphragms (16)	Replace
		Spring (22) collapsed or out of level	Reposition and replace if necessary
		AC out of class due to unsuitable spring (22)	Replace
		SG out of class due to dirty or worn plug (17)	Clean and replace if needed
	PM 182 MONITOR	Reinforced gasket (8) dirty or worn	Clean and replace if needed
		O-ring (35) friction	Lubricate if needed replace
		Stem guide O-ring (36) frictions	Lubricate if needed replace
		I/DWR (52) frictions	Lubricate if needed replace
		I/DWR (51) friction	Lubricate if needed replace
		Breakage of the diaphragm (50)	Replace
		SG out of class due to reinforced gasket (8) dirty or damaged	Clean and replace if needed

Failure	Device	Possible causes	Intervention
Failed sealing Zero flow rate	PRE-REGULATOR R14/A	Failed sealing of the O-ring (17)	Clean and replace if needed
		Failed sealing of the O-ring (18)	Clean and replace if needed
		Failed sealing of the O-ring (20)	Clean and replace if needed
		Diaphragm (10) worn	Replace
	204/A SERIES PILOTS	Upper diaphragm (16) worn	Replace
		Dirty or worn plug (17)	Clean and replace if needed
	PM 182 MONITOR	Reinforced gasket (8) dirty or worn	Clean and replace if needed
		Failed sealing of the O-ring (35)	Clean and replace if needed
		Failed sealing of the O-ring (36) of the balancing piston	Clean and replace if needed
		Failed sealing of the O-ring (42)	Clean and replace if needed
		Failed sealing of the O-ring (43)	Clean and replace if needed

Failure	Device	Possible causes	Intervention
Downstream pressure increases	PRE-REGULATOR R14/A	Plug (5) damaged	Replace
	204/A SERIES PILOTS	Plug (17) damaged	Replace
		Diaphragm holder (16) and plug (17) assembly locked in open position	Check and clean if necessary
		Plug spring (21) collapsed	Replace
		Downstream sensing line obstructed	Clean
	PM 182 MONITOR	Reinforced gasket (8) damaged	Replace
		Ice between reinforced gasket (8) and plug (71)	Increase the gas inlet temperature of the regulator
		Soiling between reinforced gasket (8) and plug (71)	Clean and check gas filtration
		Plug (71) locked	Clean and check the movements
		Imperfect element unit unit tightening	Tighten properly
		Transfer hole clogged	Clean
		Plug guide O-ring (35) damaged	Replace
		Stem guide O-ring (36) frictions	Lubricate if needed replace
		I/DWR (52) frictions	Lubricate if needed replace
		I/DWR (51) friction	Lubricate if needed replace
Spring (80) collapsed	Replace		

Failure	Device	Possible causes	Intervention
Downstream pressure decreases	PRE-REGULATOR R14/A	Filter (13) clogged	Replace
		Reinforced gasket (9) damaged	Replace
		Diaphragm (10) damaged	Replace
		Plug (5) locked in in closing	Clean and lubricate
		Plug (5) obstructed	Clean
	204/A SERIES PILOTS	Plug (17) locked in shut-off position	Clean and lubricate
		Diaphragms (16) damaged	Replace
		Diaphragm holder (16) and plug (17) assembly locked in open position	Check and clean if necessary
		Valve seat (3) clogged	Clean
		Spring (22) collapsed	Replace
	PM 182 MONITOR	No upstream pressure	Check line filter cartridges for clogging
		Plug (71) locked	Clean and check the movements
		Dirty O-ring (35)	Clean and replace if needed
		Stem guide O-ring (36) frictions	Lubricate if needed replace
		I/DWR (52) frictions	Lubricate if needed replace
		I/DWR (51) friction	Lubricate if needed replace
Ice formation		Increase gas inlet temperature regulator	
Diaphragm (50) damaged		Replace	
Stem guide (11) loose	Screw		

Tab. 10.187.

10.4.4 - TROUBLESHOOTING OF THE SA SLAM-SHUT VALVE

Failure	Device	Possible causes	Intervention
Incorrect tripping pressure	PRESSURE SWITCHES MOD. SA-91, SA-92, SA-93	Incorrect maximum (32) and/or minimum (31) spring setting	Carry out the calibration again by adjusting the ring nuts
		Levers with friction	Clean and lubricate the linkage and replace the pressure switch if necessary
		Springs (31, 32) collapsed	Replace
		Springs (31, 32) out of level	Refit
Impossible to reset	PRESSURE SWITCHES MOD. SA-91, SA-92, SA-93	Incorrect maximum (32) and/or minimum (31) spring setting	Carry out the calibration again by adjusting the ring nuts
		Downstream pressure is not consistent with the minimum and/or maximum setting of the slam-shut device	Adjust the downstream pressure
		Levers broken or chipped	Replace pressure switch
		Diaphragm breakage (16) if there is a minimum spring-load	Replace
		Manual release button (6) locked	Clean and lubricate
Failure to provide service	SLAM-SHUT VALVE SA	Plug (151) locked in opening	Clean and lubricate
		I/DWR (175) dirty or damaged	Clean and replace if needed
		Spring (152) collapsed	Replace
		Stem (114) locked	Clean and lubricate
	PRESSURE SWITCHES MOD. SA-91, SA-92, SA-93	Diaphragm (16) breakage if min. spring is missing	Replace
		Locked lever mechanisms	Clean and lubricate
Downstream pressure increase with slam-shut device shutting off	SLAM-SHUT VALVE SA	Plug profile (151) damaged	Replace
		O-ring (176) not sealing	Clean and replace if needed
		Reinforced gasket (8) not sealing	Clean and replace if needed
		O-ring (39) not sealing	Clean and replace if needed

Tab. 10.188.

10.4.5 - SB/82 SLAM-SHUT VALVE TROUBLESHOOTING

⚠ WARNING!

If the built-in slam-shut valve tripped, close the inlet and outlet valves (V1 and V2) of the line before any other operation and discharge pressure.

Failure	Device	Possible causes	Intervention
Incorrect release pressure	SLAM-SHUT VALVE SB/82 BUILT-IN SLAM-SHUT VALVE	Incorrect spring calibration maximum and/or minimum	Repeat calibration by adjusting the ring nuts. If the minimum setting is also required, recalibrate the maximum and minimum springs several times in this sequence
		Lever mechanisms with friction	Clean and lubricate the levers and if needed replace the pressure switch
	PRESSURE SWITCHES MOD. 100	Springs (11.17) collapsed	Replace
		Springs (11.17) out of level	Refit
Impossible to reset	SLAM-SHUT VALVE SB/82 BUILT-IN SLAM-SHUT VALVE	Incorrect maximum and/or minimum spring setting	Carry out the calibration again by adjusting the ring nuts
		The downstream pressure is not consistent with the minimum and/or maximum slam-shut device setting	Adjust the downstream pressure
		Levers broken or chipped	Change the standard box containing the entire complex
	PRESSURE SWITCHES MOD. 100	Diaphragm (43) breakage if min. spring is installed	Replace
		Release button manual locked	Clean and lubricate. Check that the reset pressure is consistent with the pressure switch settings
Failure to provide service	SLAM-SHUT VALVE SB/82 BUILT-IN SLAM-SHUT VALVE	Blocked stem (6) in opening	Clean and lubricate
		Locked lever mechanisms	Clean and lubricate
	PRESSURE SWITCHES MOD. 100	Diaphragm breakage (43) if min. spring is missing	Replace

Failure	Device	Possible causes	Intervention
Downstream pressure increase with slam-shut device shutting off	SLAM-SHUT VALVE SB/82 BUILT-IN SLAM-SHUT VALVE DN 1" - 3"	Failed sealing of the O-ring (40)	Clean and replace if needed
		Plug pad (19) not sealing	Clean and replace if needed
		Conical seat (8) damaged	Replace
		Failed sealing of the O-ring (39)	Clean and replace if needed
	SLAM-SHUT VALVE SB/82 BUILT-IN SLAM-SHUT VALVE DN 4" - 8"	Failed sealing of the O-ring (40)	Clean and replace if needed
		Plug pad (19) not sealing	Clean and replace if needed
		Failed sealing of the O-ring (44)	Clean and replace if needed
		Conical seat (8) damaged	Replace
		Failed sealing of the O-ring (39)	Clean and replace if needed
	SLAM-SHUT VALVE SB/82 BUILT-IN SLAM-SHUT VALVE DN 10"	Failed sealing of the O-ring (42)	Clean and replace if needed
		Reinforced gasket (8) not sealing	Clean and replace if needed
		Failed sealing of the O-ring (39)	Clean and replace if needed
		Valve seat (2) damaged	Replace
	BYPASS DEVICE HP2/2	Failed sealing of the pad O-ring (5)	Clean and replace if needed
		Failed sealing of the O-ring (15)	Clean and replace if needed
		Valve seat (6) damaged	Replace
Failed sealing of the O-ring (20)		Clean and replace if needed	

Tab. 10.189.

10.4.6 - HB/97 SLAM-SHUT VALVE TROUBLESHOOTING

WARNING!

If the built-in slam-shut valve tripped, close the inlet and outlet valves (V1 and V2) of the line before any other operation and discharge pressure.

Failure	Device	Possible causes	Intervention
Incorrect release pressure	PRESSURE SWITCHES MOD. 100	Incorrect maximum and/or minimum spring setting	Repeat calibration by adjusting the ring nuts
		Lever mechanisms with friction	Clean and lubricate the levers and if necessary replace the pressure switch
		Springs (11.17) collapsed	Replace
		Springs (11.17) out of level	Refit
Impossible to reset	SLAM-SHUT VALVE HB/97 BUILT-IN SLAM-SHUT VALVE	Stem (6) locked due to friction	Clean and lubricate
		Stem (6) locked in shut-off position	Clean and lubricate
		Plug (71) locked due to friction	Clean and lubricate
		U-ring (63) damaged	Replace
		I/DWR ring (64) damaged	Replace
	PRESSURE SWITCHES MOD. 100	Incorrect maximum and/or minimum spring setting	Repeat calibration by adjusting the ring nuts
		The downstream pressure is not consistent with the maximum and/or minimum slam-shut device setting	Adjust the downstream pressure
		Lever mechanisms with friction	Clean and lubricate levers and if needed replace the pressure switch
		Breakage of the diaphragm (43) with minimum spring pressure	Replace
		Release button manual locked	Clean and lubricate
	BYPASS DEVICE HP2/2	Filter (11) clogged	Replace

Failure	Device	Possible causes	Intervention
Delayed shut-off	LAMINATION VALVE AR100	Filter (5) clogged	Replace
	PRESSURE REGULATOR R44/SS	Lower diaphragm (16) breakage	Replace
		Upper diaphragm (16) breakage	Replace
		Failed sealing of the upper O-ring (53)	Clean and replace if needed
		Failed sealing of the lower O-ring (53)	Clean and replace if needed
		Failed sealing of the O-ring (11)	Clean and replace if needed
		Failed sealing of the O-ring (35)	Clean and replace if needed
		Balancing piston (42) locked	Clean and lubricate
		Failed sealing of the O-ring (62)	Clean and replace if needed
	SAFETY VALVE VS/FI	Failed sealing	Check and clean if necessary
	VALVE 3/2	Outer O-rings (46) not sealing	Clean and replace if needed
		Failed sealing of the O-ring (47)	Clean and replace if needed
		Failed sealing of the O-ring (48)	Clean and replace if needed
		Pad (16) dirty or damaged	Clean and replace if needed
	SLAM-SHUT VALVE HB/97 BUILT-INSLAM- SHUT VALVE	Stem (6) with friction	Clean and lubricate
		Plug (71) with friction	Clean and lubricate
	VALVE 3/2	Failed sealing of the balancing piston O-ring (36)	Clean and replace if needed
Gasket (16) locked		Clean and replace if needed	
	Clogged vents	Check and clean if necessary	

Failure	Device	Possible causes	Intervention
Failure to provide service	SLAM-SHUT VALVE HB/97 BUILT-INSLAM-SHUT VALVE	Stem (6) locked in opening	Clean and lubricate
		Plug (71) locked in opening	Clean and lubricate
		O-ring (36) not sealing	Clean and replace if needed
		I/DWR ring (64) damaged	Replace
	PRESSURE SWITCHES MOD. 100	Diaphragm breakage (43) if min. spring is missing	Replace
		Locked lever mechanisms	Check and if necessary clean and lubricate
	VALVE 3/2	Pin (6) locked	Check and if necessary clean and lubricate
		Lip pad (16) locked	Clean and replace if needed
		Clogged vents	Check and clean if needed
Unintentional intervention	SLAM-SHUT VALVE HB/97 BUILT-INSLAM-SHUT VALVE	Failed sealing of the O-ring (40)	Clean and replace if needed
		Failed sealing of the lower O-ring (36)	Clean and replace if needed
		Failed sealing of the O-ring (39)	Clean and replace if needed
		Failed sealing of the U-ring (63)	Clean and replace if needed
		Failed sealing of the O-ring (43)	Clean and replace if needed
		Failed sealing of the upper O-ring (62)	Clean and replace if needed
		Failed sealing of the O-ring (42)	Clean and replace if needed
	PRESSURE REGULATOR R44/SS	Lower diaphragm (16) not sealing	Clean and replace if needed
		Failed sealing of the O-ring (28)	Clean and replace if needed
		Failed sealing of the O-ring (29)	Clean and replace if needed
		Failed sealing of the O-ring (26.1)	Clean and replace if needed
	SAFETY VALVE VS/FI	Pad (3) not sealing	Clean and replace if needed
	VALVE 3/2	Gasket (16) locked	Clean and replace if needed
		Outer O-rings (46) not sealing	Clean and replace if needed
		Failed sealing of the O-ring (47)	Clean and replace if needed
		Failed sealing of the O-ring (48)	Clean and replace if needed

Failure	Device	Possible causes	Intervention
Downstream pressure increase with slam-shut device shutting off	SLAM-SHUT VALVE HB/97 BUILT-IN SLAM-SHUT VALVE	Reinforced gasket (8) dirty or damaged	Clean and replace if needed
		Failed sealing of the O-ring (39)	Clean and replace if needed
		Plug profile (71) damaged	Replace
		Failed sealing of the O-ring (88)	Clean and replace if needed
	BYPASS DEVICE HP2/2	Failed sealing of the O-ring (87)	Clean and replace if needed
		Failed sealing of the O-ring (21)	Clean and replace if needed
		Damaged seat profile (6)	Replace
		Pad (12) dirty or damaged	Clean and replace if needed
		Failed sealing of the O-ring (24)	Clean and replace if needed

Tab. 10.190.

11 - UNINSTALLATION AND DISPOSAL

11.1 - GENERAL SAFETY WARNINGS

HAZARD!



Make sure that there are no ignition sources in the work area set up to uninstall and/or dispose of the equipment.

WARNING!

Before proceeding with uninstallation and disposal, make the equipment safe by disconnecting it from any power supply.

11.2 - QUALIFICATION OF THE OPERATORS IN CHARGE

Commissioning

Operator qualification	Installer
PPE required	 <p> WARNING!</p> <p>The PPE listed in this table is related to the risk associated with the equipment. For the required PPE to protect against risks associated with the workplace, installation or operating conditions, please refer to:</p> <ul style="list-style-type: none"> • the regulations in force in the country of installation; • any information provided by the Safety Manager at the installation facility.
Equipment required	Please refer to the chapter “7 - Commissioning/maintenance equipment”.

Tab. 11.191.

11.3 - UNINSTALLATION

WARNING!

Before any intervention, it is necessary:

- to ensure that the line on which the equipment is installed is shut off upstream and downstream;
 - to operate the slam shut valve in manual mode by pressing the release button (Pos. 10 - Figure 4.14.).
- Next, check that the pressure indicated by the pressure gauge installed on the LINE OFF 2.0 device (Pos. 7.3 - Figure 8.41.) is 0 bar, ensuring complete depressurisation of the line.

NOTICE!

For equipment uninstallation procedures, please refer to the installation procedures (see chapter “6 - installation”), proceeding in reverse order.

11.4 - INFORMATION REQUIRED IN CASE OF RE-INSTALLATION

NOTICE!

Should the equipment be reused after uninstallation, please refer to chapters:

- “6 - installation”;
- “8 - Commissioning”.

11.5 - DISPOSAL INFORMATION

NOTICE!

Bear in mind that the laws in force in the country where the system is installed must be complied with. Illegal or incorrect disposal involves the application of the penalties provided for by the regulations in force in the country of installation.

NOTICE!

Proper disposal prevents damage to man and the environment and promotes the reuse of precious raw materials.

The equipment was manufactured with materials that can be recycled by specialised companies. To dispose of the equipment correctly, proceed as indicated in Tab. 11.192:

Step	Action
1	Set up a large work area free from obstacles where to safely dismantle the equipment.
2	Sort the various components by type of material for easier recycling through separate collection.
3	Send the materials obtained in Step 2 to a specialised company.

Tab. 11.192.

The equipment in any possible configuration consists of the following materials:

Material	Disposal/recycling indications
Plastic	It must be dismantled and disposed of separately.
Lubricants/Oils	They must be collected and delivered to the appropriate specialized and authorized collection and disposal centres.
Steel/Cast Iron	Disassemble and collect separately. It must be recycled through the specific collection centres.
Stainless steel	Disassemble and collect separately. It must be recycled through the specific collection centres.
Aluminium	Disassemble and collect separately. It must be recycled through the specific collection centres.
Pneumatic/electric components	They must be dismantled in order to be reused if they are still in good condition or, if possible, overhauled and recycled.

Tab. 11.193.

NOTICE!

Please refer to the chapter “9 - Maintenance and functional checks” to better identify the composition of the equipment and its parts.

12 - RECOMMENDED SPARE PARTS

12.1 - GENERAL WARNINGS

 **NOTICE!**

If non-original spare parts are used, PIETRO FIORENTINI S.p.A. their declared performance cannot be guaranteed.

It is recommended to use original spare parts PIETRO FIORENTINI S.p.A.

PIETRO FIORENTINI S.p.A. shall not be held liable for any damage caused by using non-original parts..

12.2 - HOW TO REQUEST SPARE PARTS

 **NOTICE!**

For specific information, please refer to the sales network of PIETRO FIORENTINI S.p.A.

PAGE INTENTIONALLY LEFT BLANK

13 - CALIBRATION TABLES

13.1 - CALIBRATION TABLES FOR 200/A SERIES PILOTS AND PRE-REGULATORS

The REVAL 182 regulator uses the 201/A pilots with the R31/A pre-regulator. The PM/182 monitor uses the 204/A pilots with the R14/A pre-regulator.

The setting ranges of the different pilots and pre-regulators are shown in the tables below:

Pilot 201/A							
Pos.	Spring item code	Spring colour	d	Lo	De	Min.	Max.
1	2702820	Blue	7	100	35	20	30
2	2703045	Brown	7,5			30.001	44
3	2703224	Grey	8			44.001	60
d = Wire Diameter (mm) Lo = Spring Length (mm) De = External Diameter (mm) Min./Max. = pressure (bar)							

Tab. 13.194.

Pilot 204/A							
Pos.	Spring item code	Spring colour	d	Lo	De	Min.	Max.
1	2701260	White	3,5	60	35	0,2	1
2	2701530	Yellow	4			1,001	2
3	2702070	Orange	5			2,001	6
4	2702450	Red	6			6,001	12
d = Wire Diameter (mm) Lo = Spring Length (mm) De = External Diameter (mm) Min./Max. = pressure (bar)							

Tab. 13.195.

Pre-regulator R31/A							
Pos.	Spring item code	Spring colour	d	Lo	De	Min.	Max.
1	2700493	Yellow	1.8	40	22	0.18	0.36
2	2700525	Orange	2			0.25	0,44
d = Wire Diameter (mm) Lo = Spring Length (mm) De = External Diameter (mm) Min./Max. = pressure (bar)							

Tab. 13.196.

Pre-regulator R14/A							
Pos.	Spring item code	Spring colour	d	Lo	De	Min.	Max.
1	2700525	Orange	2	40	22	0,65	2,15
2	2700645	Red	2.3			1,25	2.8
3	2700775	Green	2.5			1.95	3,6
d = Wire Diameter (mm) Lo = Spring Length (mm) De = External Diameter (mm) Min./Max. = pressure (bar)							

Tab. 13.197.

13.2 - CALIBRATION TABLES FOR PRESSURE SWITCHES MOD. SA

Listed below are the calibration tables of possible pressure switches in the SA built-in slam-shut valve:

Mod. SA-91 - Max. pressure							
Pos.	Spring item code	Spring colour	d	Lo	De	Min.	Max.
1	2700680	Brown	2.3	60	35	0.025	0,045
2	2700830	Red/black	2.5			0.046	0.076
3	2700920	White/yellow	2.8			0.076	0.1
4	2701040	White/orange	3			0,101	0.165
5	2701260	White	3,5			0,166	0.3
6	2701530	Yellow	4			0,301	0.58
7	2701790	Yellow/black	4.5			0,581	0.9
8	2701070	Orange	5			0,901	1.1

d = Wire Diameter (mm) **Lo** = Spring Length (mm) **De** = External Diameter (mm) **Min./Max.** = pressure (bar)

Tab. 13.198.

Mod. SA-91 - Min pressure							
Pos.	Spring item code	Spring colour	d	Lo	De	Min.	Max.
1	2700338	White	1,3	40	15	0.01	0.025
2	2700377	Yellow	1.5			0.026	0,045
3	2700464	Orange	1,7			0.046	0,095
4	2700513	Red	2			0,096	0,125
5	2700713	Green	2.3			0.126	0,2
6	2700750	Black	2.5			0,201	0,5
7	2700985	Brown	3			0,501	0.9

d = Wire Diameter (mm) **Lo** = Spring Length (mm) **De** = External Diameter (mm) **Min./Max.** = pressure (bar)

Tab. 13.199.

Mod. SA-92 - Max pressure							
Pos.	Spring item code	Spring colour	d	Lo	De	Min.	Max.
1	2701260	White	3,5	60	35	0,7	1,01
2	2701530	Yellow	4			1.011	1,96
3	2701790	Yellow/black	4.5			1,961	3,2
4	2702070	Orange	5			3,201	3,75
5	2702280	White/red	5.5			3,751	5

d = Wire Diameter (mm) **Lo** = Spring Length (mm) **De** = External Diameter (mm) **Min./Max.** = pressure (bar)

Tab. 13.200.

Mod. SA-92 - Min pressure

Pos.	Spring item code	Spring colour	d	Lo	De	Min.	Max.
1	2700513	Red	2	40	15	0.25	0,4
2	2700713	Green	2.3			0.401	0,62
3	2700750	Black	2.5			0,621	1,55
4	2700985	Brown	3			1,551	3,01

d = Wire Diameter (mm) Lo = Spring Length (mm) De = External Diameter (mm) Min./Max. = pressure (bar)

Tab. 13.201.
Mod. SA-93 - Max pressure

Pos.	Spring item code	Spring colour	d	Lo	De	Min.	Max.
1	2701530	Yellow	4	60	35	3	4.3
2	2701790	Yellow/black	4.5			4,301	7
3	2702070	Orange	5			7.001	8,5
4	2702280	White/red	5.5			8,501	13,3

d = Wire Diameter (mm) Lo = Spring Length (mm) De = External Diameter (mm) Min./Max. = pressure (bar)

Tab. 13.202.
Mod. SA-93 - Min pressure

Pos.	Spring item code	Spring colour	d	Lo	De	Min.	Max.
1	2700713	Green	2.3	40	15	0.8	1.4
2	2700750	Black	2.5			1,401	3,9
3	2700985	Brown	3			3,901	7,7

d = Wire Diameter (mm) Lo = Spring Length (mm) De = External Diameter (mm) Min./Max. = pressure (bar)

Tab. 13.203.

13.3 - CALIBRATION TABLES FOR PRESSURE SWITCHES MOD. 100

Listed below are the calibration tables of possible pressure switches in the SB/82 and HB/97 built-in slam-shut valves:

Mod. 101M/101MH - Max pressure							
Pos.	Spring item code	Spring colour	d	Lo	De	Min.	Max.
1	2700820	Orange	2.5	60	35	0,02	0,04
2	2700830	Red/black	2.5			0,041	0,06
3	2701040	White/orange	3			0,061	0,125
4	2701260	White	3,5			0,126	0,24
5	2701530	Yellow	4			0,241	0,47
6	2701790	Yellow/black	4.5			0,471	1
d = Wire Diameter (mm) Lo = Spring Length (mm) De = External Diameter (mm) Min./Max. = pressure (bar)							

Tab. 13.204.

Mod. 101M - Min pressure							
Pos.	Spring item code	Spring colour	d	Lo	De	Min.	Max.
1	2700338	White	1,3	40	15	0.01	0.022
2	2700377	Yellow	1.5			0.023	0,04
3	2700464	Orange	1,7			0.041	0.1
4	2700513	Red	2			0,101	0,15
5	2700713	Green	2.5			0,151	0,26
d = Wire Diameter (mm) Lo = Spring Length (mm) De = External Diameter (mm) Min./Max. = pressure (bar)							

Tab. 13.205.

Mod. 102M/102MH - Max pressure							
Pos.	Spring item code	Spring colour	d	Lo	De	Min.	Max.
1	2701260	White	3,5	60	35	0,2	0.8
2	2701530	Yellow	4			0.801	1,6
3	2701790	Yellow/black	4.5			1,601	2.6
4	2702280	White/red	5.5			2,601	5.5
d = Wire Diameter (mm) Lo = Spring Length (mm) De = External Diameter (mm) Min./Max. = pressure (bar)							

Tab. 13.206.

Mod. 102M - Min pressure							
Pos.	Spring item code	Spring colour	d	Lo	De	Min.	Max.
1	2700513	Red	2	40	15	0,05	0,199
2	2700713	Green	2.3			0,2	0,4
3	2700750	Black	2.5			0.401	0.8
4	2700985	Brown	3			0.801	2.8
d = Wire Diameter (mm) Lo = Spring Length (mm) De = External Diameter (mm) Min./Max. = pressure (bar)							

Tab. 13.207.

Mod. 102MH - Min pressure								
Pos.	Spring item code	Spring colour	d	Lo	De	Min.	Max.	
1	2700985	Brown	3	40	15	2.8	4,2	
	2700980	Blue	3	35				
2	2700985	Brown	3	40		15	4,201	5.5
	2700985	Brown	3					

d = Wire Diameter (mm) **Lo** = Spring Length (mm) **De** = External Diameter (mm) **Min./Max.** = pressure (bar)

Tab. 13.208.

Mod. 103M/103MH - Max pressure							
Pos.	Spring item code	Spring colour	d	Lo	De	Min.	Max.
1	2701530	Yellow	4	60	35	2	4
2	2701790	Yellow/black	4.5			4.001	7,5
3	2702280	White/red	5.5			7.501	15
4	2702450	Red	6			15.001	22

d = Wire Diameter (mm) **Lo** = Spring Length (mm) **De** = External Diameter (mm) **Min./Max.** = pressure (bar)

Tab. 13.209.

Mod. 103M - Min pressure							
Pos.	Spring item code	Spring colour	d	Lo	De	Min.	Max.
1	2700464	Orange	1,7	40	15	0,2	0,5
2	2700513	Red	2			0,501	0,8
3	2700713	Green	2.3			0.801	1,7
4	2700750	Black	2.5			1,701	4
5	2700985	Brown	3			4.001	8

d = Wire Diameter (mm) **Lo** = Spring Length (mm) **De** = External Diameter (mm) **Min./Max.** = pressure (bar)

Tab. 13.210.

Mod. 103MH - Min pressure								
Pos.	Spring item code	Spring colour	d	Lo	De	Min.	Max.	
1	2700985	Brown	3	40	15	8	13	
2	2700980	Blue	3	35				
3	2700985	Brown	3	40		15	13.001	19
4	2700985	Brown	3					

d = Wire Diameter (mm) **Lo** = Spring Length (mm) **De** = External Diameter (mm) **Min./Max.** = pressure (bar)

Tab. 13.211.

13.4 - M/A ACCELERATOR VALVE CALIBRATION TABLES

M/A							
Pos.	Spring item code	Spring colour	d	Lo	De	Min.	Max
1	2701260	White	3.5	60	35	0.3	1
2	2701530	Yellow	4			1,001	2,1
3	2702070	Orange	5			2,101	5.5
4	2702450	Red	6			5,501	11
5	2702815	Green	7			11.001	20

d = Wire Diameter (mm) **Lo** = Spring Length (mm) **De** = External Diameter (mm)

Tab. 13.212

M/A 1							
Pos.	Spring item code	Spring colour	d	Lo	De	Min.	Max
1	2702820	Blue	7	100	35	20	33
2	2703045	Brown	7,5			33,001	43
3	2703224	Grey	8			43.001	63

d = Wire Diameter (mm) **Lo** = Spring Length (mm) **De** = External Diameter (mm)

Tab. 13.213

M/A 2							
Pos.	Spring item code	Spring colour	d	Lo	De	Min.	Max
1	2703224	Grey	8	100	35	40	75

d = Wire Diameter (mm) **Lo** = Spring Length (mm) **De** = External Diameter (mm)

Tab. 13.214

13.5 - V/25 ACCELERATOR VALVE CALIBRATION TABLES

V/25 BP							
Pos.	Spring item code	Spring colour	d	Lo	De	Min.	Max
1	2700675	Yellow	2.3	50	35	0,015	0,039
2	2700830	Red/black	2.5	60		0,04	0,079
3	2701040	White/orange	3			0.08	0,2

d = Wire Diameter (mm) **Lo** = Spring Length (mm) **De** = External Diameter (mm)

Tab. 13.215

V/25 MP							
Pos.	Spring item code	Spring colour	d	Lo	De	Min.	Max
1	2701247	Red	3,5	70	34	0,2	0.399
2	2701393	Black	3.8	68		0,4	0.6

d = Wire Diameter (mm) **Lo** = Spring Length (mm) **De** = External Diameter (mm)

Tab. 13.216

PAGE INTENTIONALLY LEFT BLANK

TM0015ENG

