

# Reflux 819/FO

High medium pressure gas regulator



Revision C - Edition 02/2026

**USER, MAINTENANCE  
AND WARNING MANUAL**

PAGE INTENTIONALLY LEFT BLANK

# 1 - INTRODUCTION

## FOREWORD

All rights reserved. No part of this publication may be reproduced, distributed, translated into other languages or transmitted by any electronic or mechanical media, including photocopies, recording or any other storage and retrieval system, for any other purposes that are not exclusively the personal use of the buyer, without the express written permission of the Manufacturer.

The manufacturer is in no way responsible for the consequences of operations carried out in a manner not in accordance with the manual.

## GENERAL REMARKS

All operating, maintenance instructions and recommendations described in this manual must be observed. In order to obtain the best performance and to keep the equipment in efficient condition, the manufacturer recommends that maintenance operations be carried out regularly.

It is of particular importance that the personnel responsible for the equipment be trained in its use, maintenance and application of the safety instructions and procedures indicated in this manual.

**COPYRIGHT 2026**

**© PIETRO FIORENTINI S.P.A.**

PAGE INTENTIONALLY LEFT BLANK

## 1.1 - REVISION HISTORY

Revision index	Date
<b>A</b>	03/2023
<b>B</b>	11/2024
<b>C</b>	02/2026

Tab. 1.1

## INDEX

<b>1 - INTRODUCTION .....</b>	<b>3</b>
1.1 - REVISION HISTORY.....	5
<b>2 - GENERAL INFORMATION .....</b>	<b>11</b>
2.1 - MANUFACTURER IDENTIFICATION .....	11
2.2 - IDENTIFICATION OF THE PRODUCT .....	11
2.3 - REGULATORY FRAMEWORK.....	11
2.4 - WARRANTY .....	11
2.5 - SYMBOLS USED IN THE MANUAL.....	12
2.6 - ADDRESSEES, SUPPLY AND STORAGE OF THE MANUAL .....	13
2.7 - LANGUAGE .....	13
2.8 - APPLIED RATING PLATES .....	14
2.8.1 - GLOSSARY FOR RATING PLATES.....	16
2.9 - GLOSSARY OF UNITS OF MEASUREMENT .....	18
2.10 - QUALIFIED PROFESSIONAL FIGURES .....	19
<b>3 - SAFETY .....</b>	<b>21</b>
3.1 - GENERAL SAFETY WARNINGS.....	21
3.2 - PERSONAL PROTECTIVE EQUIPMENT.....	22
3.3 - RESIDUAL RISKS .....	23
3.3.1 - TABLE SHOWING RESIDUAL RISKS DUE TO PRESSURE .....	24
3.3.2 - TABLE OF RESIDUAL RISKS FOR POTENTIALLY EXPLOSIVE ATMOSPHERES .....	26
3.4 - OBLIGATIONS AND PROHIBITIONS .....	28
3.5 - SAFETY PICTOGRAMS .....	28
3.6 - NOISE LEVEL .....	28

## 4 - DESCRIPTION AND OPERATION ..... 29

4.1 - GENERAL DESCRIPTION .....	29
4.1.1 - REGULATOR REACTION MODES.....	30
4.2 - OPERATION.....	30
4.3 - DESIGNED USE.....	32
4.3.1 - INTENDED USE .....	32
4.3.2 - REASONABLY FORESEEABLE MISUSE .....	32
4.3.3 - TYPES OF FLUIDS .....	32
4.4 - TECHNICAL FEATURES/PERFORMANCE .....	33
4.5 - POSSIBLE CONFIGURATIONS .....	34
4.5.1 - BUILT-IN SILENCER.....	35
4.5.1.1 - BUILT-IN SILENCER DB/819.....	35
4.5.1.2 - BUILT-IN SILENCER LDB/171.....	36
4.5.2 - PM/819 MONITOR.....	37
4.5.2.1 - M/A ACCELERATING VALVE .....	41
4.5.3 - SLAM-SHUT VALVE .....	42
4.5.3.1 - SB/82 BUILT-IN SLAM-SHUT VALVE .....	42
4.5.3.2 - HB/97 BUILT-IN SLAM-SHUT VALVE.....	44
4.5.4 - SLAM-SHUT VALVE PRESSURE SWITCHES .....	46

## 5 - TRANSPORT AND HANDLING ..... 49

5.1 - SPECIFIC WARNINGS FOR TRANSPORT AND HANDLING .....	49
5.1.1 - PACKAGING AND FASTENERS USED FOR TRANSPORT .....	50
5.2 - PHYSICAL CHARACTERISTICS OF THE EQUIPMENT .....	52
5.2.1 - REFLUX 819/FO (+LDB/171).....	52
5.2.2 - REFLUX 819/FO + DB/819 .....	54
5.2.3 - REFLUX 819/FO + PM/819.....	56
5.2.4 - REFLUX 819/FO + SB/82 .....	58
5.2.5 - REFLUX 819/FO + HB/97 .....	60
5.2.6 - REFLUX 819/FO + DB/819 + PM/819.....	62
5.2.7 - REFLUX 819/FO + DB/819 + SB/82 .....	64
5.2.8 - REFLUX 819/FO + DB/819 + HB/97 .....	66
5.3 - EQUIPMENT ANCHORING AND LIFTING METHOD.....	68
5.3.1 - FORKLIFT HANDLING METHOD.....	69
5.3.2 - CRANE HANDLING METHOD.....	71
5.4 - PACKAGING REMOVAL.....	72
5.4.1 - PACKAGING DISPOSAL .....	72
5.5 - STORAGE AND ENVIRONMENTAL CONDITIONS .....	73
5.5.1 - PRE-INSTALLATION WARNINGS AFTER PROLONGED STORAGE .....	73

## 6 - INSTALLATION ..... 75

6.1 - INSTALLATION PRE-REQUISITES.....	75
6.1.1 - ENVIRONMENTAL CONDITIONS ALLOWED.....	75
6.1.2 - CHECKS BEFORE INSTALLATION.....	76
6.2 - SPECIFIC SAFETY INSTRUCTIONS FOR THE INSTALLATION PHASE .....	77
6.3 - GENERAL INFORMATION ON CONNECTIONS .....	78
6.4 - REGULATOR INSTALLATION POSITIONS.....	79
6.5 - INSTALLATION PROCEDURE .....	80
6.5.1 - EQUIPMENT INSTALLATION PROCEDURE .....	80
6.5.2 - CONNECTION OF THE SENSING LINES TO THE DOWNSTREAM PIPING.....	80
6.6 - POST-INSTALLATION AND PRE-COMMISSIONING CHECKS .....	82

## 7 - COMMISSIONING/MAINTENANCE EQUIPMENT..... 83

7.1 - LIST OF EQUIPMENT.....	83
7.2 - EQUIPMENT NEEDED FOR THE DIFFERENT CONFIGURATIONS .....	85

## 8 - COMMISSIONING ..... 89

8.1 - GENERAL WARNINGS .....	89
8.1.1 - SAFETY REQUIREMENTS FOR COMMISSIONING .....	89
8.2 - PRELIMINARY PROCEDURES FOR COMMISSIONING .....	90
8.3 - PROPER COMMISSIONING CHECK .....	91
8.4 - CALIBRATION OF ANY ACCESSORIES.....	91
8.5 - REGULATOR COMMISSIONING PROCEDURE .....	92
8.6 - COMMISSIONING PROCEDURE FOR THE REFLUX 819/FO REGULATOR WITH BUILT-IN MONITOR PM/819.....	94
8.7 - COMMISSIONING PROCEDURE FOR THE REFLUX 819/FO REGULATOR WITH BUILT-IN PM/819 MONI- TOR AND M/A THROTTLE.....	96
8.8 - COMMISSIONING PROCEDURE FOR THE REFLUX 819/FO REGULATOR WITH BUILT-IN SLAM-SHUT VALVE SB/82 .....	98
8.8.1 - CHECKING THE SB/82 SLAM-SHUT VALVE FOR PROPER SEALING WHEN CLOSING .....	98
8.8.2 - COMMISSIONING OF THE REGULATOR REFLUX 819/FO WITH SLAM-SHUT VALVE SB/82.....	101
8.8.3 - CALIBRATION PROCEDURE FOR PRESSURE SWITCHES MODELS 102M/102MH ÷ 105M/105MH	104
8.9 - COMMISSIONING PROCEDURE FOR THE REFLUX 819/FO REGULATOR WITH INCORPORATED SLAM- SHUT VALVE SB/97 .....	106
8.9.1 - CHECKING THE HB/97 INCORPORATED SLAM-SHUT VALVE FOR SEALING WHEN CLOSING ....	106
8.9.2 - COMMISSIONING OF THE REFLUX 819/FO REGULATOR WITH HB/97 SLAM-SHUT VALVE .....	107
8.9.3 - LINE OFF 2.0 COMMISSIONING AND CALIBRATION PROCEDURE FOR HB/97 BUILT-IN SLAM-SHUT VALVE .....	110
8.10 - CALIBRATION OF THE PRESSURE SWITCH FOR LINE OFF 2.0.....	111
8.11 - DEVICE CALIBRATION.....	112
8.11.1 - 200/A/FO AND 200/A SERIES PILOTS AND THE M/A THROTTLE VALVE .....	112
8.11.2 - PRESSURE SWITCHES MODELS 102M/102MH - 105M/105MH.....	112

## 9 - MAINTENANCE AND FUNCTIONAL CHECKS..... 113

9.1 - GENERAL WARNINGS .....	113
9.2 - PERIODICALLY CHECKING AND INSPECTING THE EQUIPMENT FOR PROPER OPERATION.....	115
9.3 - ROUTINE MAINTENANCE .....	116
9.3.1 - GENERAL SAFETY WARNINGS.....	116
9.3.2 - REPLACEMENT FREQUENCY FOR COMPONENTS SUBJECT TO WEAR .....	117
9.4 - ROUTINE MAINTENANCE PROCEDURES.....	119
9.4.1 - TIGHTENING TORQUES REFLUX 819/FO .....	120
9.4.2 - REPLACING ELEMENTS SUBJECT TO WEAR AND ABRASION.....	151
9.4.3 - REGULATOR MAINTENANCE PROCEDURE REFLUX 819/FO.....	152
9.4.4 - DB/819 SILENCER MAINTENANCE PROCEDURE .....	206
9.4.5 - PM/819 BUILT-IN MONITOR MAINTENANCE PROCEDURE .....	214
9.4.6 - PILOT MAINTENANCE PROCEDURE 200/A/FO AND 200/A SERIES + R14/A/FO AND R14/A PRE-REGULATOR.....	244
9.4.7 - M/A ACCELERATOR VALVE MAINTENANCE PROCEDURE.....	264
9.4.8 - SB/82 INCORPORATED SLAM-SHUT VALVE MAINTENANCE PROCEDURE .....	268
9.4.9 - MAINTENANCE PROCEDURE FOR PRESSURE SWITCHES MOD. 100.....	298
9.4.10 - HB/97 BUILT-IN SLAM-SHUT VALVE MAINTENANCE PROCEDURE .....	310
9.4.11 - LINE OFF 2.0 MAINTENANCE PROCEDURE .....	322
9.4.12 - LINE OFF 2.0 MAINTENANCE PROCEDURE .....	346
9.4.13 - PROCEDURE FOR RECOMMISSIONING AFTER MAINTENANCE .....	347

## 10 - TROUBLESHOOTING..... 349

10.1 -GENERAL WARNINGS .....	349
10.2 -OPERATOR QUALIFICATION SPECIFICATION.....	350
10.3 -TROUBLESHOOTING PROCEDURES .....	350
10.4 -TROUBLESHOOTING TABLES .....	351
10.4.1 - TROUBLESHOOTING REFLUX 819/FO REGULATOR.....	351
10.4.2 - DB/819 SILENCER TROUBLESHOOTING .....	354
10.4.3 - APM/819 BUILT-IN MONITOR TROUBLESHOOTING .....	355
10.4.4 - SB/82 BUILT-IN SLAM-SHUT VALVE TROUBLESHOOTING.....	358
10.4.5 - HB/97 BUILT-IN SLAM-SHUT VALVE TROUBLESHOOTING.....	360

<b>11 - UNINSTALLATION AND DISPOSAL .....</b>	<b>365</b>
11.1 -GENERAL SAFETY WARNINGS.....	365
11.2 -QUALIFICATION OF THE OPERATORS IN CHARGE.....	365
11.3 -UNINSTALLATION.....	365
11.4 -INFORMATION REQUIRED IN CASE OF RE-INSTALLATION.....	366
11.5 -DISPOSAL INFORMATION.....	366
<b>12 - RECOMMENDED SPARE PARTS.....</b>	<b>367</b>
12.1 -GENERAL WARNINGS .....	367
12.2 -HOW TO REQUEST SPARE PARTS.....	367
<b>13 - CALIBRATION TABLES.....</b>	<b>369</b>
13.1 -CALIBRATION TABLES FOR 200/A/FO AND 200/A SERIES PILOTS AND R14/A/FO AND R14/A PRE-REGULATORS.....	369
13.2 -CALIBRATION TABLES FOR PRESSURE SWITCHES MOD. 100.....	371
13.3 -M/A ACCELERATOR VALVE CALIBRATION TABLES.....	374

## 2 - GENERAL INFORMATION

### 2.1 - MANUFACTURER IDENTIFICATION

<b>Manufacturer</b>	PIETRO FIORENTINI S.P.A.
<b>Address</b>	Via Enrico Fermi, 8/10 36057 Arcugnano (VI) - ITALY <b>Tel. +39 0444 968511 Fax +39 0444 960468</b> <b>www.fiorentini.com arcugnano@fiorentini.com</b>

Tab. 2.2

### 2.2 - IDENTIFICATION OF THE PRODUCT

<b>Equipment</b>	HIGH PRESSURE REGULATOR
<b>Model</b>	REFLUX 819/FO

Tab. 2.3

### 2.3 - REGULATORY FRAMEWORK

PIETRO FIORENTINI S.P.A., with registered offices in Arcugnano (Italy) - Via E. Fermi, 8/10, declares under its sole responsibility that the equipment of the REFLUX 819/FO series described in this manual is designed, manufactured, tested and checked in compliance with the requirements of EN 334 standard on gas pressure regulators.

The equipment meets the requirements of Directive 2014/68/EU (Pressure Equipment Directive PED). The assessment procedure adopted is in accordance with module H1 as per Annex III of the Directive.

#### NOTICE!

**The declaration of conformity in its original version is delivered together with the equipment and this operating and warning manual.**

### 2.4 - WARRANTY

PIETRO FIORENTINI S.P.A. guarantees that the equipment was manufactured using the best materials, with high quality workmanship, and complies with the quality requirements, specifications and performance set out in the order.



The warranty shall be considered null and void and PIETRO FIORENTINI S.P.A. shall not be liable for any damage and/or malfunctions:

- due to any acts or omissions of the purchaser or end-user, or any of their carriers, employees, agents, or any third party or entity;
- in the event that the purchaser, or a third party, makes changes to the equipment supplied by PIETRO FIORENTINI S.P.A. without the prior written approval of the latter;
- in the event of failure by the purchaser to comply with the instructions contained in these instructions, as provided by PIETRO FIORENTINI S.P.A.

#### NOTICE!

**The warranty conditions are specified in the commercial contract.**

## 2.5 - SYMBOLS USED IN THE MANUAL

Symbol	Definition
	Symbol used to identify important warnings for the safety of the operator and/or equipment.
	Symbol used to identify information of particular importance in the manual. The information may also concern the safety of the personnel involved in using the equipment.
	Obligation to consult the instruction manual/booklet. Indicates a requirement for the personnel to refer to (and understand) the operating and warning instructions of the machine before working with or on it.

Tab. 2.4

### HAZARD!

Alerts to a hazard with a high level of risk, an imminent hazardous situation which, if not prevented, will result in death or severe damage.

### WARNING!

Alerts to a hazard with a medium level of risk, a potentially hazardous situation which, if not prevented, may result in death or severe damage.

### ATTENTION!

Alerts to a hazard with a low level of risk, a potentially hazardous situation which, if not prevented, could result in minor or moderate damage.

### NOTICE!

Alerts to specific warnings, directions or notes of particular concern, that are not related to physical injury, as well as practices for which physical injury is not likely to occur.

## 2.6 - ADDRESSEES, SUPPLY AND STORAGE OF THE MANUAL

The instruction manual is intended for qualified operator responsible for using and managing the equipment throughout its service life.

It contains the necessary information to properly use the equipment and keep its functional and qualitative characteristics unchanged over time. All information and warnings for safe, correct use are also provided.

The manual, as well as the declaration of conformity and/or test certificate, is an integral part of the equipment and must always accompany it whenever it is moved or resold. It is up to the user to keep this documentation intact for reference throughout the lifespan of the equipment.

### **WARNING!**

**Removing, rewriting or editing the pages of the manual and their contents is not allowed.**

**Keep the instruction manual near the equipment, in an accessible place known by all qualified technicians involved in using and running it.**

**PIETRO FIORENTINI S.p.A. shall not be held liable for any damage to people, animals and property caused by failure to adhere to the warnings and operating procedures described in this manual.**

## 2.7 - LANGUAGE

The original manual has been drawn up in Italian.

Any translations into additional languages are to be made from the original instruction manual.

### **HAZARD!**

**The Manufacturer is not responsible for any incomplete translations. If any inconsistency is found, please refer to the text of the original manual.**

**If inconsistencies are found or the text does not make sense:**

- stop any actions;
- immediately contact the relevant offices of PIETRO FIORENTINI S.p.A.

### **WARNING!**

**PIETRO FIORENTINI S.p.A. shall be held liable for the information provided in the original manual only.**

## 2.8 - APPLIED RATING PLATES



### WARNING!

**Removing rating plates and/or replacing them with other plates is strictly not allowed.  
Should the plates be unintentionally damaged or removed, the customer must notify  
PIETRO FIORENTINI S.p.A.**

The equipment and its accessories are provided with nameplates (from Id.1 to Id.8).

The plates specify identification details of the equipment and its accessories to be provided, if necessary, to PIETRO FIORENTINI S.p.A.

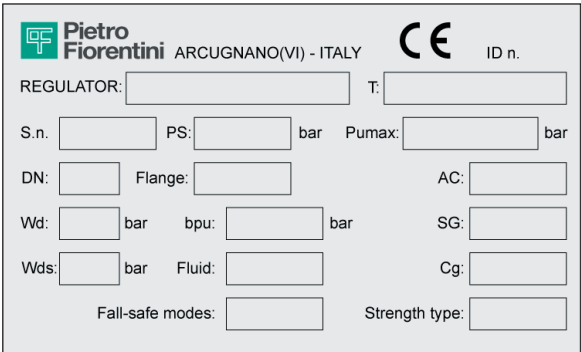
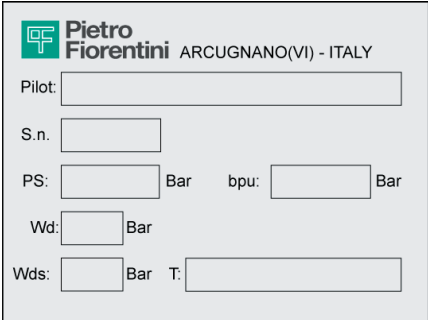
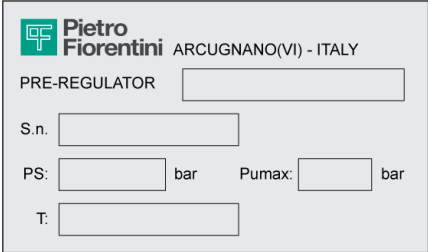
Tab. 2.5 shows the nameplates applied:

Id.	Type	Image
1	RATING PLATE REGULATOR (EC version)	
2	RATING PLATE PILOT	
3	RATING PLATE PRE-REGULATOR	
4	RATING PLATE DB SILENCER	

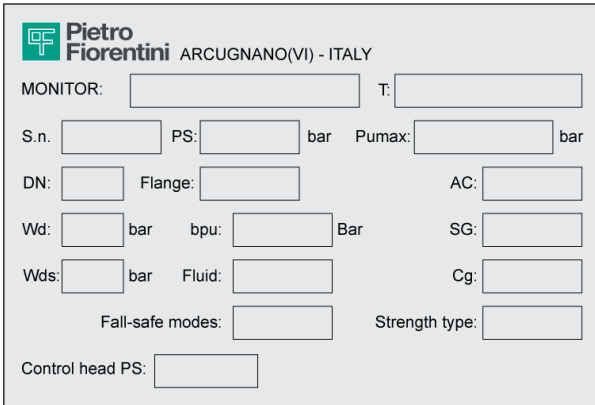
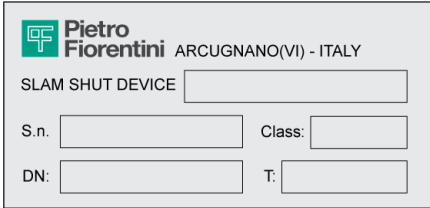
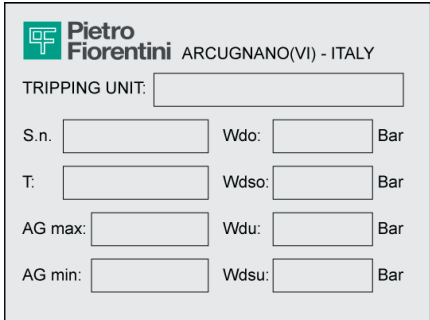
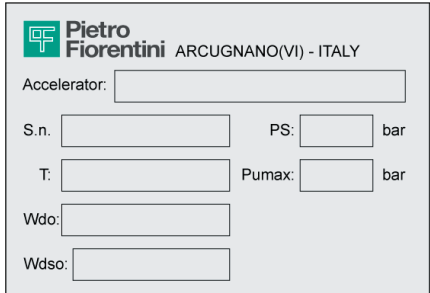
Id.	Type	Image
5	RATING PLATE MONITOR	 <p><b>Pietro Fiorentini</b> ARCUGNANO(VI) - ITALY</p> <p>MONITOR: <input type="text"/> T: <input type="text"/></p> <p>S.n. <input type="text"/> PS: <input type="text"/> bar Pumax: <input type="text"/> bar</p> <p>DN: <input type="text"/> Flange: <input type="text"/> AC: <input type="text"/></p> <p>Wd: <input type="text"/> bar bpu: <input type="text"/> Bar SG: <input type="text"/></p> <p>Wds: <input type="text"/> bar Fluid: <input type="text"/> Cg: <input type="text"/></p> <p>Fall-safe modes: <input type="text"/> Strength type: <input type="text"/></p> <p>Control head PS: <input type="text"/></p>
6	RATING PLATE SLAM-SHUT VALVE	 <p><b>Pietro Fiorentini</b> ARCUGNANO(VI) - ITALY</p> <p>SLAM SHUT DEVICE <input type="text"/></p> <p>S.n. <input type="text"/> Class: <input type="text"/></p> <p>DN: <input type="text"/> T: <input type="text"/></p>
7	RATING PLATE PRESSURE SWITCH	 <p><b>Pietro Fiorentini</b> ARCUGNANO(VI) - ITALY</p> <p>TRIPPING UNIT: <input type="text"/></p> <p>S.n. <input type="text"/> Wdo: <input type="text"/> Bar</p> <p>T: <input type="text"/> Wdso: <input type="text"/> Bar</p> <p>AG max: <input type="text"/> Wdu: <input type="text"/> Bar</p> <p>AG min: <input type="text"/> Wdsu: <input type="text"/> Bar</p>
8	RATING PLATE ACCELERATOR VALVE	 <p><b>Pietro Fiorentini</b> ARCUGNANO(VI) - ITALY</p> <p>Accelerator: <input type="text"/></p> <p>S.n. <input type="text"/> PS: <input type="text"/> bar</p> <p>T: <input type="text"/> Pumax: <input type="text"/> bar</p> <p>Wdo: <input type="text"/></p> <p>Wdso: <input type="text"/></p>

Tab. 2.5

## 2.8.1 - GLOSSARY FOR RATING PLATES

The terms and abbreviations used on nameplates are described in Tab. 2.6:

Term	Description
<b>AC</b>	Accuracy class.
<b>AG max</b>	Accuracy class of pressure boosting slam-shut valves. "OPSO" (Over pressure shut off).
<b>AG min</b>	Accuracy class of safety devices for pressure drop. "UPSO" (Under pressure shut off).
<b>bpu</b>	Range of inlet pressure for which the regulator ensures a given accuracy class.
<b>CE</b>	Marking certifying compliance with applicable European directives.
<b>Cg</b>	Flow rate coefficient.
<b>Class</b>	Alphanumeric designation used for reference purposes related to a combination of mechanical and dimensional characteristics for flanges, in accordance with the relevant parts of EN 1759 series, which includes the word Class followed by a dimensionless whole number.
<b>DN</b>	Nominal size of connections.
<b>Fail safe mode</b>	Regulator reaction mode (Fail open or Fail close).
<b>Flange</b>	Type of flanged connections or type of connection thread.
<b>Fluid</b>	Type of fluid compatible with the equipment.
<b>ID n.</b>	Number of the Notified Body participating in the conformity assessment of the equipment.
<b>Pilot</b>	Pilot family.
<b>PS</b>	Maximum permissible pressure for which the equipment was designed.
<b>Pumax</b>	Maximum inlet pressure at which the regulator can operate continuously under specific conditions.
<b>REGULATOR</b>	Equipment family.
<b>SG</b>	Shut-off pressure class.
<b>Slam-shut device</b>	Slam-shut valve family.
<b>S.n.</b>	Equipment serial number.
<b>Strength type</b>	Strength class: Integral strength (IS) or differential strength (DS).
<b>T</b>	Permissible temperature range (min. and max.) that the equipment was designed for.
<b>Tripping unit</b>	Pressure switch family.
<b>Type</b>	Accessory type and family.
<b>Wd</b>	Full setpoint range that can be obtained from the regulator by adjusting and/or replacing certain components (e.g. replacement of valve seat or control element, e.g. spring).
<b>Wdo</b>	Full setpoint range with regard to tripping caused by increased pressure in the pressure switch built into the slam-shut valve. This range can be obtained by adjusting and/or replacing the components (for example, spring or sensitive element).
<b>Wds</b>	Full setpoint range that can be obtained from the regulator by adjusting but not replacing the components.
<b>Wdso</b>	Full setpoint range with regard to tripping caused by increased pressure in the pressure switch built into the slam-shut valve. This range can be obtained by adjusting but not replacing the components.

Term	Description
<b>Wdu</b>	Full setpoint range with regard to tripping caused by decreased pressure in the pressure switch built into the slam-shut valve. This range can be obtained by adjusting and/or replacing the components (for example, spring or sensitive element).
<b>Wdsu</b>	Full setpoint range with regard to tripping caused by decreased pressure in the pressure switch built into the slam-shut valve. This range can be obtained by adjusting but not replacing the components.

Tab. 2.6

## 2.9 - GLOSSARY OF UNITS OF MEASUREMENT

Type of measurement	Unit of measurement	Description
<b>Volumetric flow rate</b>	Sm <sup>3</sup> /h	Standard cubic metres per hour
	Scfh	Standard cubic feet per hour
<b>Pressure</b>	bar	Unit of measurement in the CGS system
	psi	Pounds per square inch
	"wc	water column inch
	Pa	Pascal
<b>Temperature</b>	°C	Degree centigrade
	°F	Fahrenheit degree
	K	Kelvin
<b>Tightening torque</b>	Nm	Newton metre
	ft-lbs	Foot per pound
<b>Sound pressure</b>	dB	Decibel
<b>Other measurements</b>	V	Volt
	W	Watt
	Ω	Ohm

Tab. 2.7

## 2.10 - QUALIFIED PROFESSIONAL FIGURES

Qualified operators in charge of using and managing the equipment throughout its technical service life:

Professional figure	Definition
<b>Mechanical maintenance technician</b>	<p>Qualified technician able to:</p> <ul style="list-style-type: none"> <li>perform preventive/corrective maintenance operations on all mechanical parts of the equipment subject to maintenance or repair;</li> <li>access all device parts for visual inspection, equipment checks, adjustments and settings.</li> </ul> <p>The maintenance mechanical technician is not authorised to operate on live electrical systems (if any).</p>
<b>Mechanical electric</b>	<p>Qualified technician able to:</p> <ul style="list-style-type: none"> <li>perform preventive/corrective maintenance operations on all electrical parts of the device subject to maintenance or repair;</li> <li>read wiring diagrams and check the correct functional cycle;</li> <li>perform adjustments and operate on electrical systems for maintenance, repair and replacement of worn parts.</li> </ul> <p>The electrical maintenance technician can operate in the presence of voltage inside electrical panels, junction boxes, control equipment etc. only if he/she is deemed to be suitable (S.P.).</p> <p>For general requirements, refer to the IEC EN 50110-1:2014 standard.</p>
<b>Worker in charge of transport, handling, unloading and placement on site</b>	<p>Operator qualified to:</p> <ul style="list-style-type: none"> <li>the use of lifting equipment</li> <li>handle materials and equipment.</li> </ul> <p>The equipment must be lifted and handled strictly in accordance with the instructions provided by the manufacturer as well as the regulations in force at the place where the equipment is installed.</p>
<b>Installer</b>	<p>Qualified operator able to:</p> <ul style="list-style-type: none"> <li>carry out all the operations necessary to properly install the equipment safely;</li> <li>perform all the operations necessary to properly operate the equipment and system safely.</li> </ul>
<b>User's technician</b>	<p>Technician trained and authorized to use and manage the equipment for the activities for which it was supplied. They must:</p> <ul style="list-style-type: none"> <li>be able to perform all operations required for the proper functioning of the equipment and the system, and for their safety and that of any personnel present;</li> <li>have proven experience in properly using the equipment similar to that described in this manual, and be trained, informed and instructed in this regard.</li> </ul> <p>The technician may carry out maintenance only if authorised/qualified to do so.</p>

Tab. 2.8

PAGE INTENTIONALLY LEFT BLANK

## 3 - SAFETY

### 3.1 - GENERAL SAFETY WARNINGS

#### WARNING!

The equipment described in this manual is:

- a device subjected to pressure in pressurised systems;
- normally installed in systems carrying flammable gases (for example: natural gas).

#### WARNING!

If the gas used is a combustible gas, the installation area of the equipment is defined as a 'danger zone' as there are residual risks that potentially explosive atmospheres may be generated.

In "danger zones" and in the immediate vicinity, the following are required:

- there must not be any effective sources of ignition;
- no smoking.

#### ATTENTION!

Authorised operators must not carry out operations or services on their own initiative that do not fall within their competence.

Never operate the equipment:

- while under the influence of intoxicating substances such as alcohol;
- if you are using drugs that may slow reaction times.

#### NOTICE!

The employer must train and inform operators on how to behave during operations and on the equipment to be used.





Before installation, commissioning or maintenance, operators must:

- take note of the safety regulations applicable to the place of installation they are working in;
- obtain the necessary permits to operate when required;
- wear the personal protective equipment required by the procedures described in this instruction manual;
- ensure that the required collective protective equipment and safety information are available in the area they are operating in;

### 3.2 - PERSONAL PROTECTIVE EQUIPMENT

Tab. 3.9 shows the personal protective equipment (PPE) and its description. An obligation is associated with each symbol. Personal protective equipment means any equipment intended to be worn by the worker in order to protect them against one or several risks that are likely to threaten their safety or health during work.

For the operators in charge, depending on the type of work requested, the most appropriate PPE of the following will be reported and must be used:

Symbol	Meaning
	<b>Obligation to use safety or insulated gloves.</b> Indicates a requirement for the personnel to use safety or insulated gloves.
	<b>Obligation to use safety goggles.</b> Indicates a requirement for personnel to use protective goggles for eye protection.
	<b>Obligation to use safety shoes.</b> Indicates a requirement for personnel to use accident-prevention safety shoes.
	<b>Obligation to use noise protection equipment.</b> Indicates a requirement for the personnel to use ear muffs or ear plugs to protect their hearing.
	<b>Obligation to wear protective clothing.</b> Indicates a requirement for personnel to wear specific protective clothing.
	<b>Obligation to use a protective mask.</b> Indicates a requirement for the personnel to use respiratory masks in the event of a chemical risk.
	<b>Obligation to use a protective helmet.</b> Indicates a requirement for the personnel to use protective helmets.
	<b>Obligation to wear high visibility vests.</b> Indicates a requirement for the personnel to use high visibility vests.

Tab. 3.9

#### **WARNING!**

Each licensed operator is obliged to:

- **take care of his/her own health and safety and that of other people in the workplace who are affected by his/her actions or omissions, in accordance with the training, instructions and equipment provided by the employer;**
- **appropriately use the PPE made available;**
- **immediately report to the employer, the manager or the person in charge any deficiencies in the equipment and devices, as well as any dangerous conditions they may become aware of.**

### **3.3 - RESIDUAL RISKS**

In accordance with the requirements of directive PED 2014/68/EU, point 1.2 of Annex I, below is an assessment of the risks associated with the equipment and an indication of the principles adopted for their prevention, according to the following classification:

- a) Elimination and/or reduction of the risk.
- b) Application of appropriate protective measures.
- c) Information to users about residual risks.

### 3.3.1 - TABLE SHOWING RESIDUAL RISKS DUE TO PRESSURE

Risk and Hazard	Event and Cause	Effect and Consequence	Solution and Prevention
<b>Pressurised gas leakage. Projection of metallic and non-metallic pressurised parts.</b>	<ul style="list-style-type: none"> <li>Violent impact;</li> <li>Impact (also due to falling, improper handling, etc.).</li> </ul>	<ul style="list-style-type: none"> <li>Deformation;</li> <li>Broken connections and, if pressurised, even burst.</li> </ul>	a. Handling and installation with appropriate devices to avoid localised stress. b. Installation in suitable places and spaces with appropriate guards and packaging. c. Information in the instructions for use and warning.
<b>Pressurised gas leakage. Projection of metallic and non-metallic pressurised parts. metallic and not in leakage</b>	<ul style="list-style-type: none"> <li>Use of inappropriate fluids.</li> </ul>	<ul style="list-style-type: none"> <li>Corrosion;</li> <li>Embrittlement;</li> <li>Explosion.</li> </ul>	a. The user must check compliance of the used fluid with the specifications on the data plate.
<b>Pressurised gas leakage. Projection of metallic and non-metallic pressurised parts. metallic and not in leakage</b>	<ul style="list-style-type: none"> <li>Operation at temperatures below the minimum permissible temperature.</li> </ul>	<ul style="list-style-type: none"> <li>Embrittlement;</li> <li>Breakage;</li> <li>Explosion.</li> </ul>	a. Install in places where the temperature is not below the minimum permissible temperature and/or insulate the equipment adequately. b. The minimum temperature allowed is indicated on the data plate.
<b>Pressurised gas leakage. Projection of metallic and non-metallic pressurised parts. Explosion.</b>	<ul style="list-style-type: none"> <li>Overpressure or exceedance of the rated limit values (maximum pressure allowed)</li> </ul>	<ul style="list-style-type: none"> <li>Explosion;</li> <li>Breaks;</li> <li>Cracks;</li> <li>Permanent deformations.</li> </ul>	a. The device has appropriate design safety margins. b. The user must check the maximum pressure applicable to the equipment. c. The maximum allowable pressure is highlighted on the appropriate plate on the equipment.
<b>Falling of the equipment.</b>	<ul style="list-style-type: none"> <li>Dangerous handling.</li> </ul>	<ul style="list-style-type: none"> <li>Deformation;</li> <li>Cracking;</li> <li>Breakage.</li> </ul>	a. The user must have suitably sized lifting equipment. b. The above requirements are referred to in the equipment use and warning manual.
<b>Pressurised fluid leakage. Projection of metallic and non-metallic pressurised parts. metallic and not in leakage</b>	<ul style="list-style-type: none"> <li>Incorrect fastening of the equipment.</li> </ul>	<ul style="list-style-type: none"> <li>Deformation;</li> <li>Breakage.</li> </ul>	a. The device is equipped with unified type process connections and press fittings. b. The user must ensure correct fixing to the line. c. Directions in the instructions for use and warning.

Risk and Hazard	Event and Cause	Effect and Consequence	Solution and Prevention
<b>Explosion of the device.</b> <b>Pressurised fluid leakage</b> <b>Projection of metallic and non-metallic pressurised parts.</b> <b>metallic.</b>	<ul style="list-style-type: none"> <li>Operation at temperatures above the maximum permissible temperature.</li> </ul>	<ul style="list-style-type: none"> <li>Reduction of mechanical resistance and breakage of the device;</li> <li>Explosion.</li> </ul>	a. The user must equip the system with suitable control and safety devices. b. The maximum temperature allowed is indicated on the data plate.
<b>Pressurised gas leakage</b>	<ul style="list-style-type: none"> <li>Equipment maintenance with the system running.</li> </ul>	<ul style="list-style-type: none"> <li>Inappropriate opening of pressurised chambers.</li> </ul>	a. The user must perform any maintenance with the equipment not running. b. The above requirements are referred to in the use and warning instructions.
<b>Pressurised gas leakage</b> <b>Projection of metallic and non-metallic pressurised parts.</b> <b>metallic and not in leakage</b>	<ul style="list-style-type: none"> <li>External loads bearing on the device.</li> </ul>	<ul style="list-style-type: none"> <li>Deformation;</li> <li>Cracking and fissure formation;</li> <li>If under pressure, even burst.</li> </ul>	a. With the exclusion of what is set out in the design, the user must verify that no additional concentrated load bears on the device.
<b>Pressurised gas leakage</b> <b>Projection of metallic and non-metallic pressurised parts.</b> <b>metallic and not in leakage</b>	<ul style="list-style-type: none"> <li>Electrostatic potential differential stray currents.</li> </ul>	<ul style="list-style-type: none"> <li>Localised corrosion in the device.</li> </ul>	b. The user must equip the device with the necessary protection and earthing devices. c. The above requirements are referred to in the use and warning manual.
<b>Pressurised gas leakage</b> <b>Projection of metallic and non-metallic pressurised parts.</b> <b>metallic and not in leakage</b>	<ul style="list-style-type: none"> <li>Humidity;</li> <li>Environments with aggressive atmosphere.</li> </ul>	<ul style="list-style-type: none"> <li>Deterioration of external surfaces;</li> <li>Corrosion.</li> </ul>	a. The user must periodically check the state of conservation of the external surfaces. b. The above requirements are referred to in the use and warning instructions.

Tab. 3.10

### 3.3.2 - TABLE OF RESIDUAL RISKS FOR POTENTIALLY EXPLOSIVE ATMOSPHERES

Tab. 3.11 shows the conditions that can lead to the generation of a potentially explosive atmosphere respectively for:

- REFLUX 819/FO pressure regulator;
- PM/819 monitor;
- SB/82 or HB/97 slam shut valves.

Considering that the silencer does not have active functional parts, in this analysis it is considered an integral part of the REFLUX 819/FO regulator.

The table is valid for use with natural gas with a density of no more than 0.8; for different densities, the installation and environmental conditions must also be evaluated.

 **WARNING!**

**If the gas used is a combustible gas, the installation area of the equipment is defined as a 'danger zone' as there are residual risks that potentially explosive atmospheres may be generated. There must be no effective sources of ignition in 'danger zones' and in close proximity thereto.**

Operational operational	Atmosphere potentially explosive	Normative references	Management measures included in the instructions for use and warning
<b>First start-up</b>	No	<ul style="list-style-type: none"> <li>• During the production cycle and before the CE marking according to Directive 2014/68/EU, the external tightness of the equipment is checked at a value of 1.1 PS (in accordance with Standard EN 334).</li> <li>• Before commissioning, the external sealing of the system portion on which the equipment is installed is checked at a suitable pressure (in accordance with the provisions of standards EN 12186 and EN 12279).</li> </ul>	The instructions for use indicate the need to meet the requirements in Standards EN 12186 and EN 12279.
<b>Operation in normal conditions</b>	No	<p>The indications in the previous point apply, in addition:</p> <ul style="list-style-type: none"> <li>• the equipment is installed outdoors or in an environment with natural ventilation (in accordance with Standards EN 12186 and EN 12279);</li> <li>• the installation is subject to surveillance according to current national rules/good practice/the equipment manufacturer's instructions (in accordance with the provisions of Standard EN 12186 and Standard EN 12279).</li> </ul>	<p>The instructions for use indicate that:</p> <ul style="list-style-type: none"> <li>• any environment in which the equipment is installed must meet the requirement of Standards EN 12186 and EN 12279;</li> <li>• periodic checks and maintenance must be carried out during surveillance in accordance with the national rules in force (if any), and with the specific manufacturer's recommendations.</li> </ul>

Operational operational	Atmosphere potentially explosive	Normative references	Management measures included in the instructions for use and warning
<b>Breakage of the control head diaphragm (malfunction)</b>	No	<p>This event must be considered a rare malfunction.</p> <p>All atmospheric pressure chambers delimited on at least one side by a diaphragm must be channelled to a safe area (in accordance with the provisions of Standard EN 12186 and Standard EN 12279).</p>	The instructions for use indicate the need to meet the requirements of Standards EN 12186 and EN 12279.
<b>Breakage of other parts non-metallic (malfunction)</b>	No	<p>This type of malfunction is not reasonably expected as it involves static seals (to the outside) that cannot generate any external leakage.</p>	-
<b>Decommissioning</b>	No	<ul style="list-style-type: none"> <li>The pressure of the system section in which the equipment is installed must be reduced with appropriate vent lines channelled to a safe area (in accordance with the provisions of Standard EN 12186 and Standard EN 12279).</li> <li>The residual gas must be discharged as indicated above.</li> </ul>	The instructions for use indicate the need to meet the requirements of Standards EN 12186 and EN 12279
<b>Reboot</b>	No	<ul style="list-style-type: none"> <li>After reassembling the regulator, carry out an external leakage test at a convenient pressure value as specified by the manufacturer.</li> <li>Before commissioning, the external sealing of the system portion on which the equipment is installed is checked at a suitable pressure (in accordance with the provisions of standards EN 12186 and EN 12279).</li> </ul>	<p>The instructions for use indicate:</p> <ul style="list-style-type: none"> <li>the minimum conditions for testing external leakage;</li> <li>the need to meet the requirements of Standards EN 12186 and EN 12279.</li> </ul>

Tab. 3.11

### 3.4 - OBLIGATIONS AND PROHIBITIONS

The following is a list of obligations and prohibitions to be observed for the safety of the operator.

It is compulsory:



- to carefully read and understand the instructions for use and warning;
- to check whether the downstream equipment is suitably sized according to the performance required of the regulator in the actual operating condition;
- before installing the equipment, to strictly refer to the details specified on the nameplates;
- to avoid violent shocks and impacts that could damage the equipment and, as a result, cause the pressurised fluid to leak.

It is forbidden to:

- operate in various capacities on the equipment without the PPE indicated in the work procedures described in these use and warning instructions;
- operate in the presence of open flames or bring open flames close to the work area;
- smoke near the equipment or while working on it;
- use the equipment with parameters other than those indicated on the name plate;
- use the equipment with fluids other than those indicated on the rating plate and in these use and warning instructions;
- use the equipment outside the operating temperature range specified on the rating plate and in these use and warning instructions;
- service the equipment with the system portion, on which it is installed, in operation;
- install or use the equipment in environments other than those specified in these instructions for use and warning.

### 3.5 - SAFETY PICTOGRAMS

The following safety pictograms may be shown on the equipment and/or packaging PIETRO FIORENTINI S.p.A.:

Symbol	Definition
	Symbol used to identify an ELECTRICAL HAZARD.
	Symbol used to identify a GENERIC HAZARD.

Tab. 3.12

#### HAZARD!

**It is absolutely forbidden to remove the safety pictograms on the equipment.**

**The user is required to replace the safety pictograms which, following wear, removal or tampering, are illegible.**

### 3.6 - NOISE LEVEL

Depending on the operating conditions, use and required configuration, the equipment may generate noise other than that permitted by the regulations in force in the country of installation.

For the value of the noise generated by the equipment and further information, contact PIETRO FIORENTINI S.p.A.

#### ATTENTION!

**The obligation to use earmuffs or ear plugs to protect the operator's hearing remains in the event that the noise in the installation environment of the equipment (depending on specific operating conditions) exceeds the value of 85 dBA.**

## 4 - DESCRIPTION AND OPERATION

### 4.1 - GENERAL DESCRIPTION

The equipment REFLUX 819/FO is a piloted pressure regulator for medium and high pressure which reduces the inlet gas pressure, keeping the downstream value stable even when the following varies:

- inlet pressure value;
- the required flow rate within the operating conditions of the equipment.

The main elements of the equipment are:

Pos.	Description	Pos.	Description
1	Main regulator	6	Reinforced gasket
2	Piloting unit	7	Main diaphragm
3	R14/A/FO Pre-regulator	8	R14/A
4	200/A/FO series pilot	9	Spring
5	Plug	10	3-way valve

Tab. 4.13

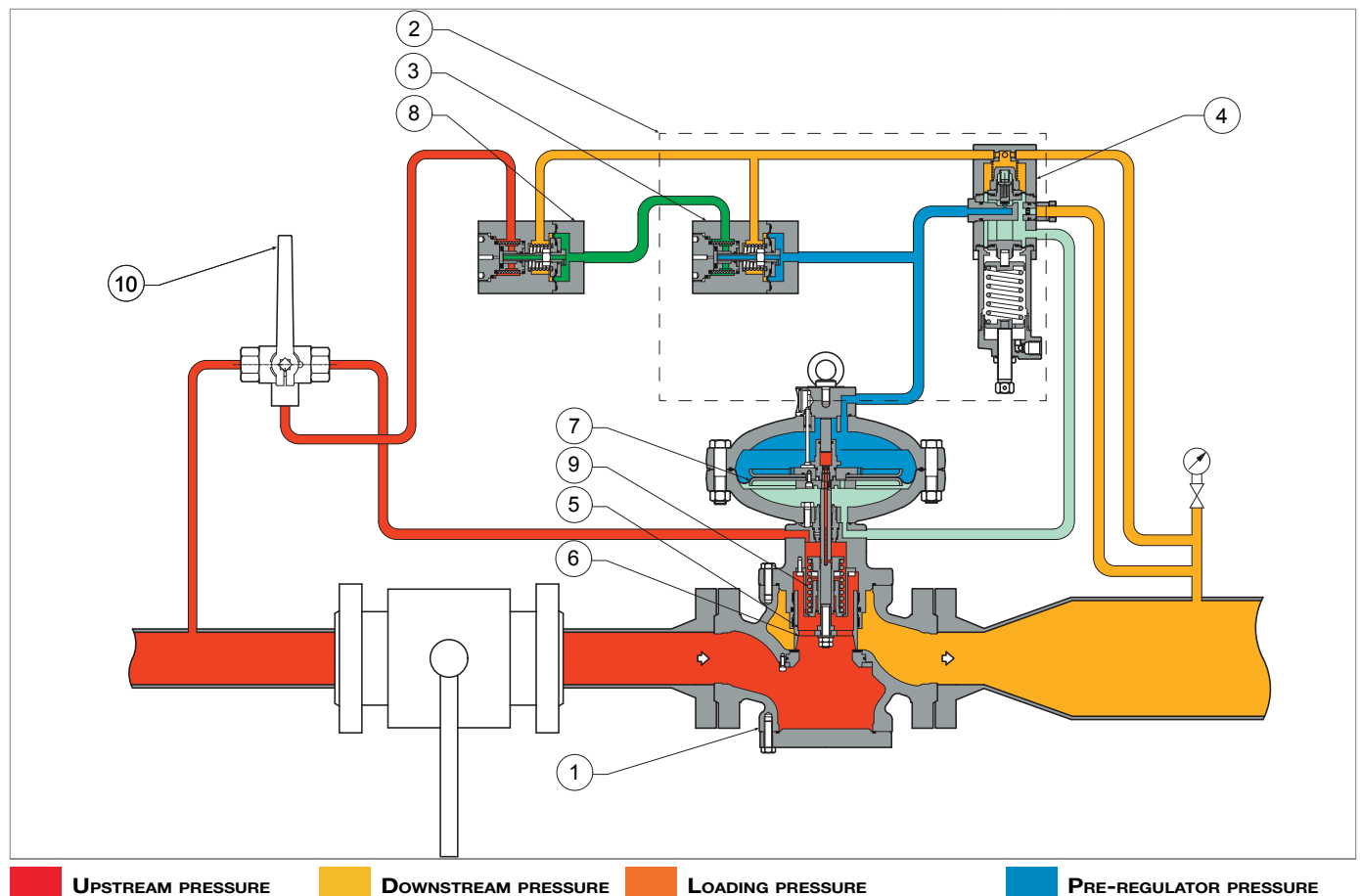

Fig. 4.1. General description REFLUX 819/FO

### 4.1.1 - REGULATOR REACTION MODES

The REFLUX 819/FO equipment is a regulator piloted with a "fail open" reaction (on-opening reaction), that is, it opens in the event of:

- breakage of main diaphragm
- breakage of the pilot diaphragm(s);
- no power supply in the pilot circuit.

### 4.2 - OPERATION

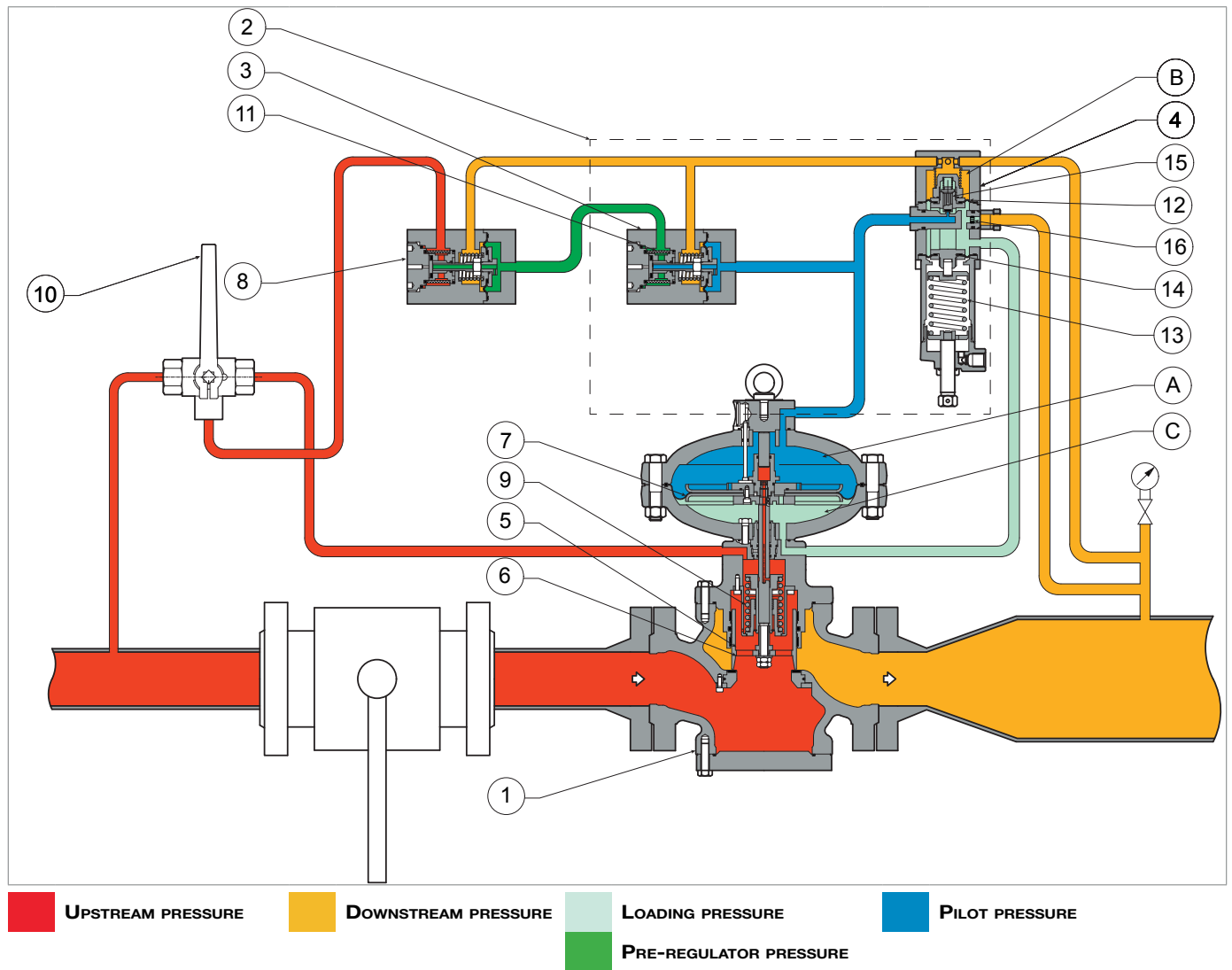

Fig. 4.2. Operation REFLUX 819/FO

Lacking pressure, the regulator plug (5) is held in the open position by the spring (9). The upstream pressure, although variable, does not change this position since the regulator plug (5) is fully balanced.

The position of the regulator plug (5) is controlled by the main diaphragm (7) on which the following forces act:

- in opening: the spring load (9), the thrust resulting from the loading pressure ( $P_m$ ) in the chamber (A);
- in closing: the thrust generated by the feed pressure from the pre-regulator ( $P_{up}$ ) into the chamber (C).

The weight of the mobile equipment acts towards the closed or open position depending on the installation position of the regulator (1) (see paragraph "DRAIN").

The loading pressure ( $P_m$ ) is obtained from the upstream piping of the regulator (1). The feed gas enters the 3-way valve (10) and the R14/A pre-regulator. It then enters the R14/A/FO pre-regulator and passes through the filter (11). Here, the pressure value is reduced to the fixed value of the pressure at the pre-regulator ( $P_{up}$ ), which depends on the calibration pressure of the regulator.

The pressure from the pre-regulator ( $P_{up}$ ) feeds the pilot (4); in turn, it regulates the value of the loading pressure ( $P_m$ ) to be fed into the chamber (C) of the regulator in order to open the plug (5) of the regulator via the opening of the plug (15) of the pilot.

The loading pressure ( $P_m$ ) is set by comparing:

- the force exerted by the pilot calibration spring (13);
- the action of the downstream pressure ( $P_d$ ), which acts on the diaphragm (12) in the chamber (B).

The drive circuit is an open circuit with continuous discharge by means of a transfer hole (16) in the pilot (4) with discharge to the downstream pressure ( $P_d$ ).

Under normal operating conditions, the plug (15) of the pilot is positioned so that the value of the loading pressure ( $P_m$ ) is such that the value of the downstream pressure ( $P_d$ ) remains around the set value.

The regulation system is balanced and guarantees a stable outlet pressure even when the inlet pressure varies.

Operating conditions	Operating consequences	Outcome
<b>Decrease in downstream pressure (<math>P_d</math>) due to:</b> <ul style="list-style-type: none"> <li>• rise in the requested flow rate;</li> <li>• drop in upstream pressure (<math>P_u</math>).</li> </ul>	Imbalance in the mobile unit (14) of the pilot (4), which causes the plug (15) of the pilot (4) to open.	<ul style="list-style-type: none"> <li>• Increase in loading pressure (<math>P_m</math>);</li> <li>• Move the regulator plug (5) during opening until the downstream pressure value (<math>P_d</math>) is restored.</li> </ul>
<b>Increased downstream pressure (<math>P_d</math>) due to:</b> <ul style="list-style-type: none"> <li>• drop in the requested flow rate;</li> <li>• increase in upstream pressure (<math>P_u</math>).</li> </ul>	The force exerted by the downstream pressure ( $P_d$ ) on the pilot diaphragm moves the mobile unit (14) and shifts the plug (15) of the pilot (4) to the shut-off position.	<ul style="list-style-type: none"> <li>• Decrease in pilot feed pressure (<math>P_{up}</math>) to loading pressure (<math>P_m</math>)</li> <li>• Decrease in loading pressure (<math>P_m</math>);</li> <li>• Move the regulator plug (5) during closing until the downstream pressure value (<math>P_d</math>) is restored.</li> </ul>

Tab. 4.14

## 4.3 - DESIGNED USE

### 4.3.1 - INTENDED USE

The equipment in question is intended for:

Operation	Permitted	Unpermitted	Work environment
<b>Adjustment of the downstream pressure for:</b>	Gaseous, and non-corrosive, fluids that have been filtered beforehand.	<ul style="list-style-type: none"> <li>Liquids.</li> <li>Any product other than those permitted.</li> </ul>	Installations to carry and convey natural gas to supply networks for: <ul style="list-style-type: none"> <li>civil use;</li> <li>industrial use.</li> </ul>

Tab. 4.15

The equipment in question is used as a main regulator.

It was designed to be used exclusively within the limits specified on the rating plate and according to the instructions and limits of use referred to in this manual.

Safe work conditions are as follows:

- use within the limits stated on the rating plate and in this manual;
- compliance with the user manual procedures;
- routine maintenance to be carried out when and how recommended;
- special maintenance to be carried out if required;
- do not tamper with and/or bypass the safety devices.

### 4.3.2 - REASONABLY FORESEEABLE MISUSE

Incorrect and reasonably foreseeable use means the use of the equipment in a way not foreseen in the phase but which can result from readily foreseeable human behaviour:

- corrosive fluids;
- fluids not properly treated upstream;
- liquids;
- instinctive reaction of an operator in the event of a malfunction, accident or breakdown while using the equipment;
- behaviour resulting from pressure to keep the machine running under all circumstances;
- behaviour resulting from carelessness;
- behaviour resulting from the use of the equipment by unauthorised and unsuitable people;
- using the equipment in a manner other than that referred to in paragraph "4.3.1 - Intended use".

Any use of the equipment other than the intended use must be previously approved in writing by PIETRO FIORENTINI S.p.A. If no written approval is provided, use shall be considered "improper".

In the event of improper use, PIETRO FIORENTINI S.p.A. shall not be held liable for any damage caused to people or property, and any type of warranty on the equipment shall be deemed void.

### 4.3.3 - TYPES OF FLUIDS

The equipment works with combustible gases used:

- in pressure control stations according to EN 12186 or EN 12279;
- in transmission and distribution networks.
- in commercial and industrial plants (after checking by contacting the Manufacturer).

#### NOTICE!

**The equipment may be also used with inert gases, subject to verification by contacting the manufacturer.**

#### 4.4 - TECHNICAL FEATURES/PERFORMANCE

The REFLUX 819/FO equipment is a medium and high pressure regulator.  
REFLUX 819/FO is a 'top entry' type regulator that can be easily serviced and equipped with on-site accessories.  
The main specifications for this regulator are:

Technical features	
Maximum allowable pressure	Up to 102 bar
Ambient temperature range	-20 °C + 60 °C
Inlet gas temperature range	-20 °C + 60 °C
Inlet pressure range (bpu)	3 ÷ 102 bar
Possible regulation range (Wd)	1 - 74 bar (depending on the pilot installed)
Minimum differential pressure	2 bar
Accuracy class (AC)	up to 2.5 (depending on operating conditions)
Lock up pressure class (SG)	up to 5 (depending on operating conditions)

Tab. 4.16

Cg and K1 coefficients								
Nominal diameter [mm]	25	50	80	100	150	200	250	300
Size [inches]	1"	2"	3"	4"	6"	8"	10"	12"
Coefficient Cg	575	2220	4937	8000	16607	25933	36535	55000
Coefficient K1	106.78	106.78	106.78	106.78	106.78	106.78	106.78	106.78

Tab. 4.17

In Tab. 4.18 the list of pilots installed on the equipment:

Equipment	Pilot type	Calibration range (bar)
REFLUX 819/FO	204/A/FO	1 ÷ 33
	205/A/FO	20 - 60
	207/A/FO	41 - 74
PM 819 MONITOR	204/A	0.3 ÷ 43
	205/A	20 - 60
	207/A	41 - 74

Tab. 4.18.

In Tab. 4.19 the list of springs for the R14/A/FO pre-reducer divided by size:

Size [inches]	Spring item code	Spring colour
1" 6" 12"	2700629	Yellow
2" 3" 4" 10"	2700645	Red
8"	2700775	Green

Tab. 4.19.

#### 4.5 - POSSIBLE CONFIGURATIONS

The REFLUX 819/FO equipment can have different configurations through the installation of the following accessories:

- Built-in silencer DB/819
- Built-in silencer LDB/171
- Incorporated monitor PM/819 (up to 10")
- Incorporated slam-shut valve SB/82 (up to 10")
- Incorporated slam-shut valve HB/97 (4" to 12")

The possible configurations are listed in Tab. 4.20:

REFLUX 819/FO	DB/819	LDB/171	PM/819	SB/82	HB/97
<b>DB/819</b>	-	No	Yes	Yes	Yes
<b>LDB/171</b>	No	-	Yes	Yes	Yes
<b>PM/819</b>	Yes	Yes	-	No	No
<b>SB/82</b>	Yes	Yes	No	-	No
<b>HB/97</b>	Yes	Yes	No	No	-

Tab. 4.20

The accessories can be installed directly at the factory or, at a later time, directly on site.

 **NOTICE!**

**The installation of accessories is described in the relevant chapter of this manual.**

## 4.5.1 - BUILT-IN SILENCER

### 4.5.1.1 - BUILT-IN SILENCER DB/819

The DB/819 silencer (1) is incorporated in the regulator (2).

The DB/819 silencer (1) attenuates the noise generated by the equipment during the rolling process. Noise is absorbed precisely where it is generated, which prevents it from propagating.

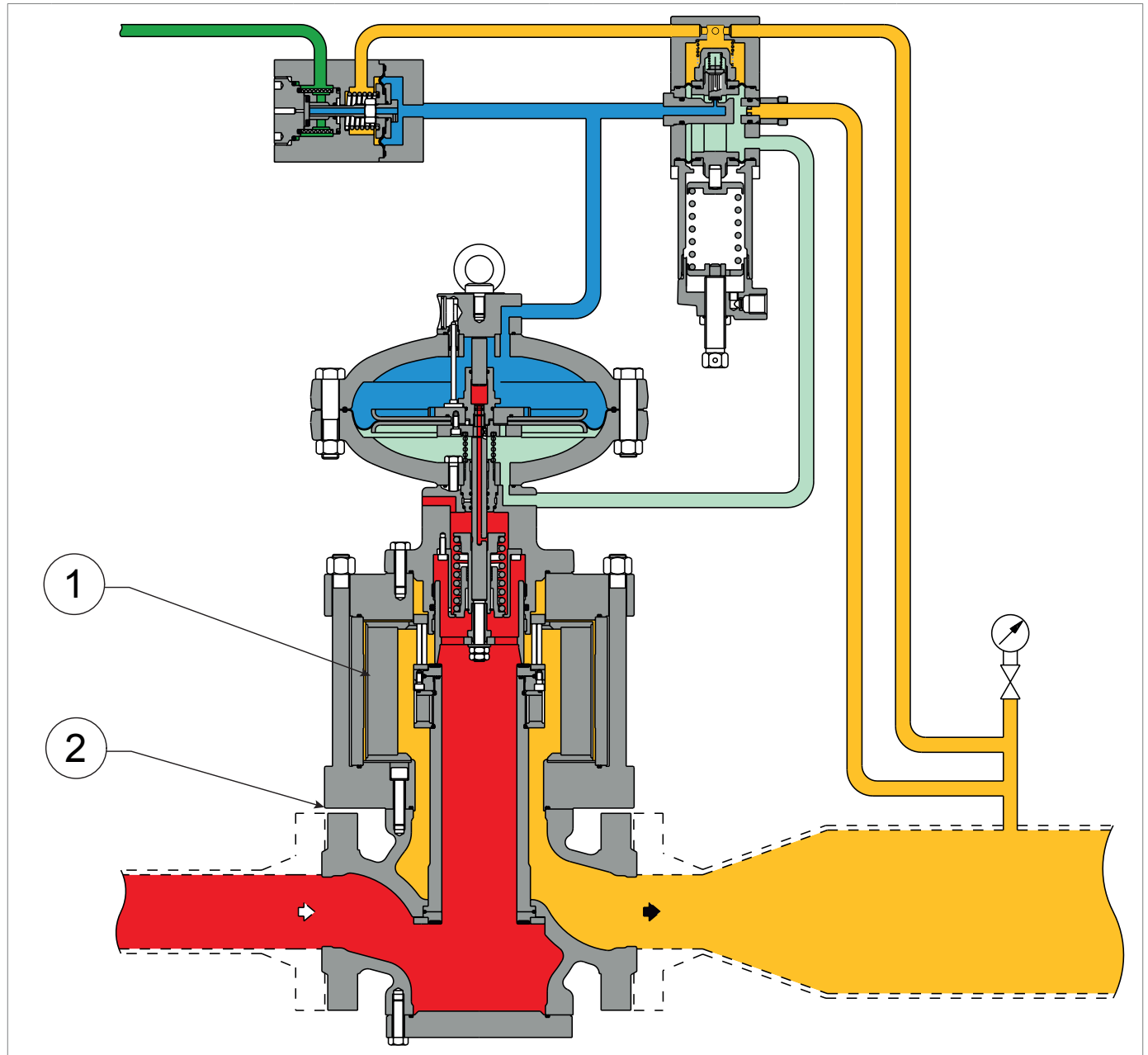

■ **UPSTREAM PRESSURE**    
 ■ **DOWNSTREAM PRESSURE**    
 ■ **LOADING PRESSURE**    
 ■ **PRE-REGULATOR PRESSURE**

Fig. 4.3. Incorporated DB/819 silencer

**4.5.1.2 - BUILT-IN SILENCER LDB/171**

The LDB/171 silencer (1) is incorporated in the regulator (2).

The LDB/171 silencer (1) reduces the noise generated by the equipment during the lamination process. Noise is absorbed precisely where it is generated, which prevents it from propagating.

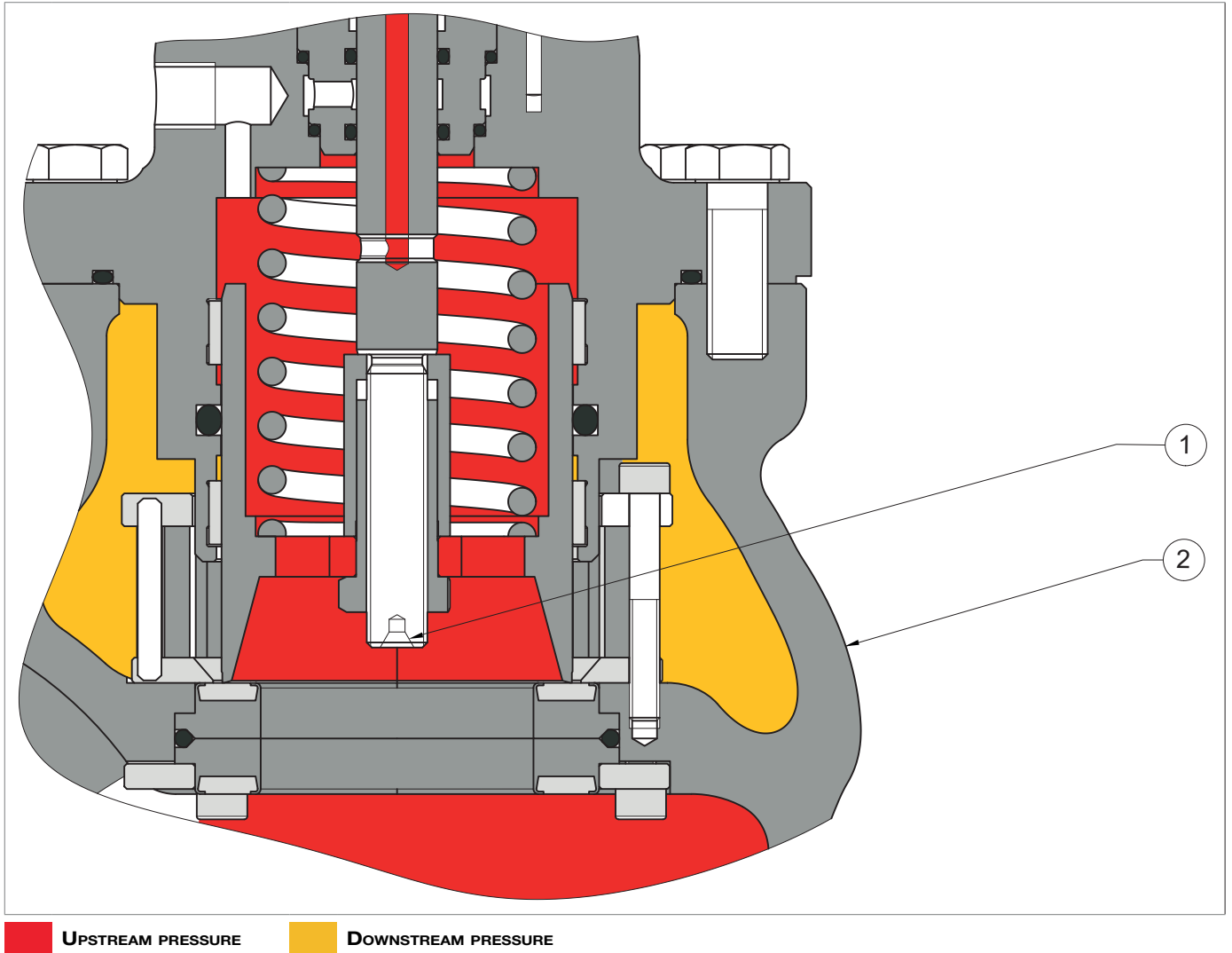

Fig. 4.4. Built-in silencer LDB/171

### 4.5.2 - PM/819 MONITOR

The PM/819 monitor (1) is installed upstream of the main pressure regulator (2).

The PM/819 monitor is used to keep the pressure value downstream of the main regulator within the preset limits in case of failure.

The PM/819 monitor (1) is assembled directly on the body of the main regulator (2), converting the equipment into two pressure regulators with a common valve body. The two regulators have the following characteristics:

- they are controlled by two distinct pilots and by independent servomotors;
- they work on independent valve seats.

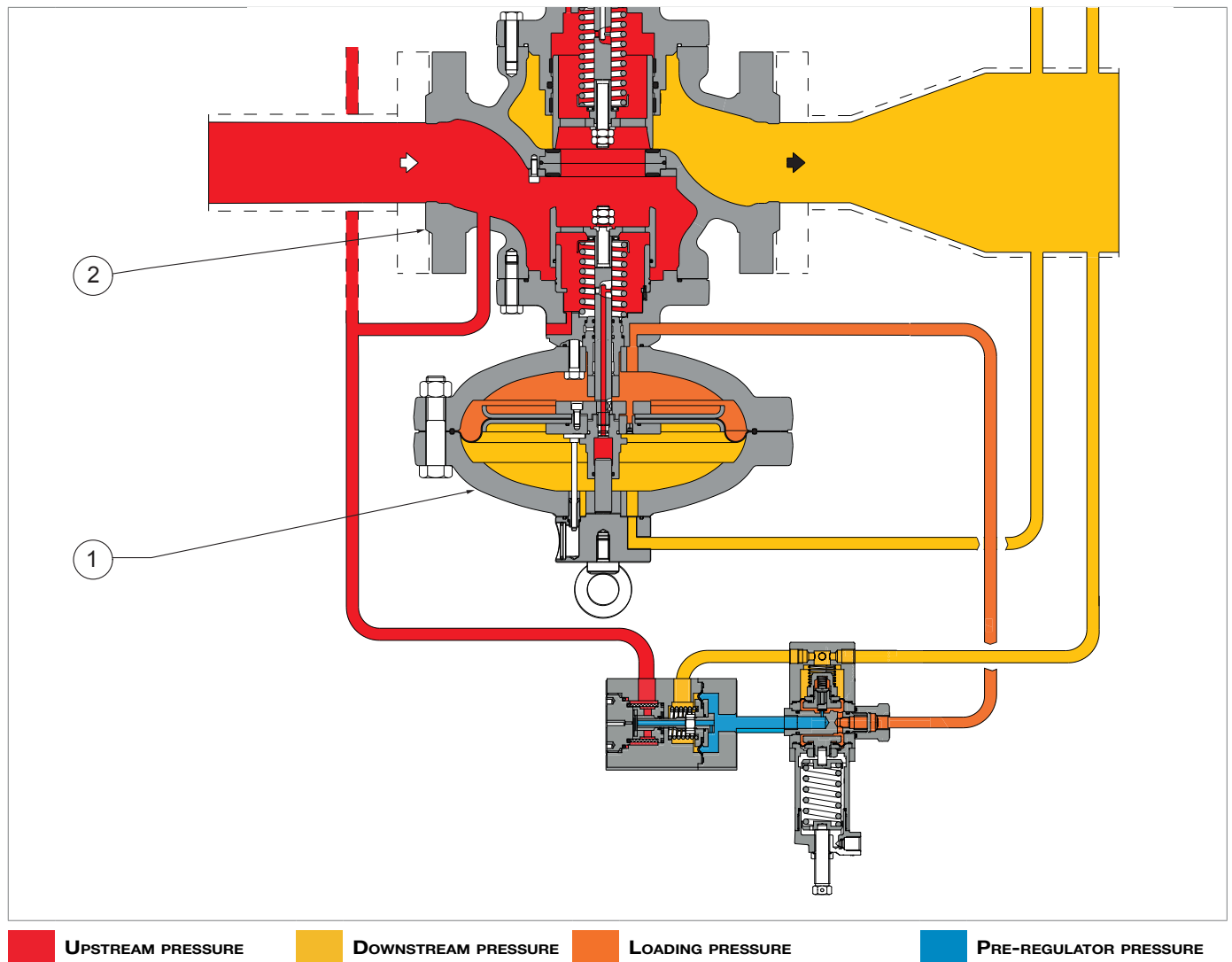

Fig. 4.5. REFLUX 819/FO with PM/819 monitor

## BUILT-IN MONITOR OPERATION

### ! NOTICE!

To check the position of the plug (3), look at the position of the stroke indicator rod (9) referring to the glass cover (10):

- open 100%;
- closed 0%.

In depressurised conditions, the plug (3) is kept in a closed position by the spring (4) and rests on the reinforced gasket (5).

The upstream pressure ( $U_p$ ), even if variable, does not change this position as the plug (3) is completely balanced, just like the stem (6), as a result of the upstream pressure ( $U_p$ ), through the hole (16), in the chamber (B).

The position of the plug (3) is controlled by the movements of the diaphragm (7) that the following act on:

- towards the closed position: the load of the spring (4) and the thrust resulting from the downstream pressure ( $P_d$ ) in the chamber (C),
- towards the open position: the thrust resulting from the loading pressure ( $P_m$ ) in the chamber (D), supplied by the pilot (8).

The weight of the mobile equipment acts towards the closed or open position depending on the installation position of the regulator (2) (see paragraph "6.4 - Regulator installation positions").

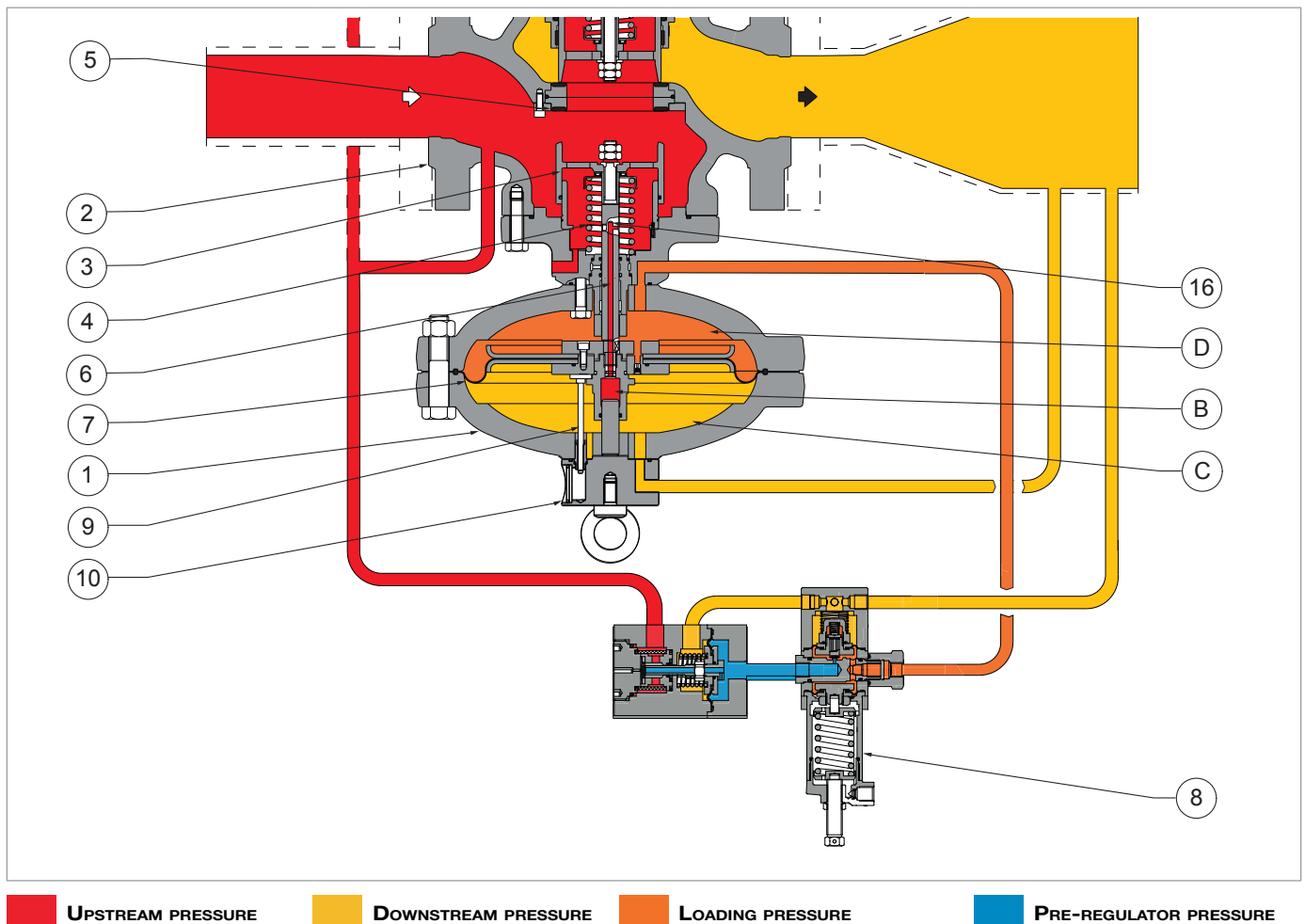

Fig. 4.6. Incorporated monitor operation

### OPERATION OF THE BUILT-IN MONITOR IN STAND-BY CONDITIONS:

The PM/819 built-in monitor (1) is normally open during standard operation as pilot (3) calibration is higher than that of the main regulator (2) pilot.

The passage of the pre-regulator pressure ( $P_{up}$ ) generated by the R14/A pre-regulator (4) through the fully open pilot (3) keeps the built-in monitor PM/819 (1) fully open.

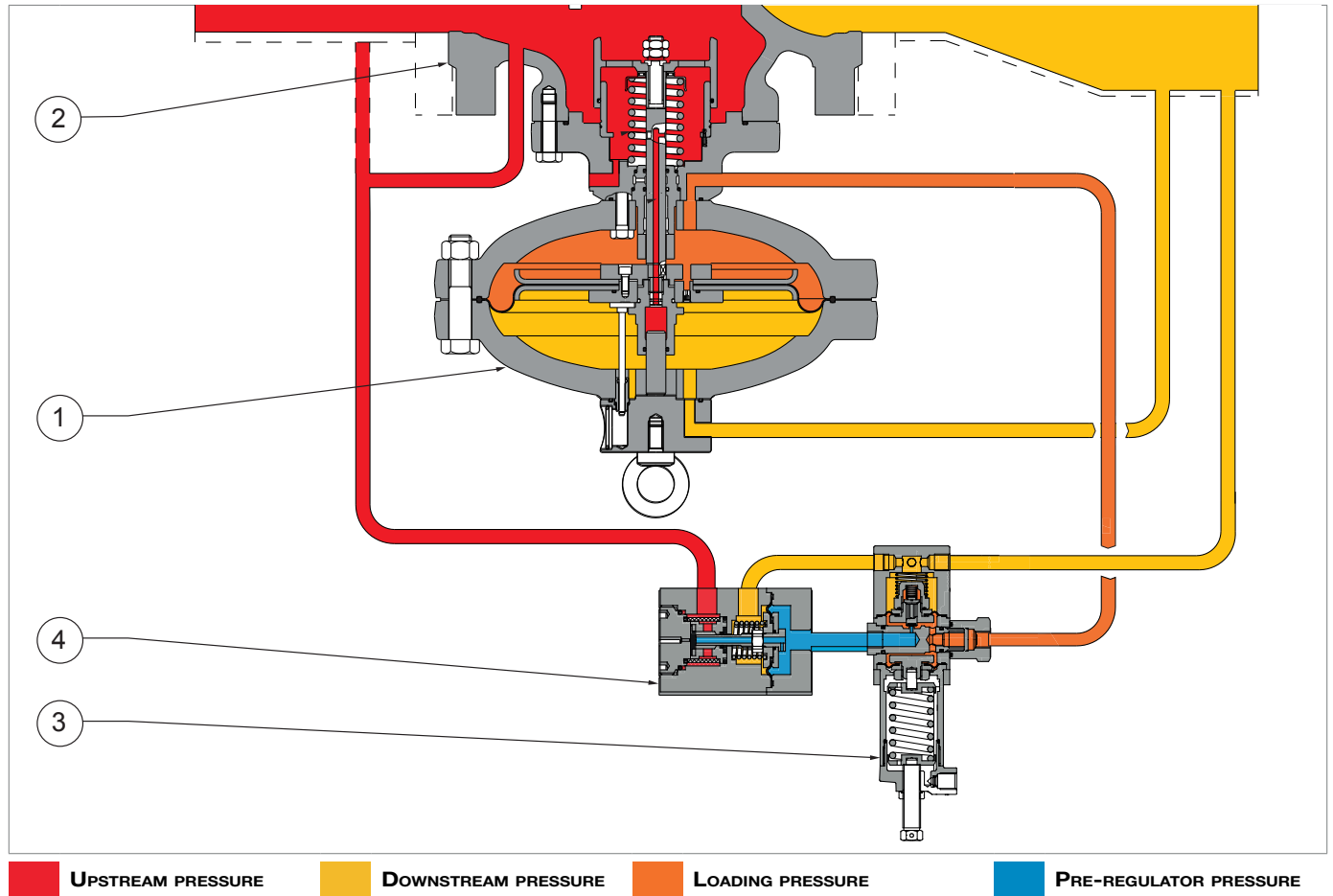

Fig. 4.7. Operation of the built-in monitor in stand-by conditions

**BUILT-IN MONITOR OPERATION IN THE EVENT OF FAILURE OF THE MAIN REGULATOR:**

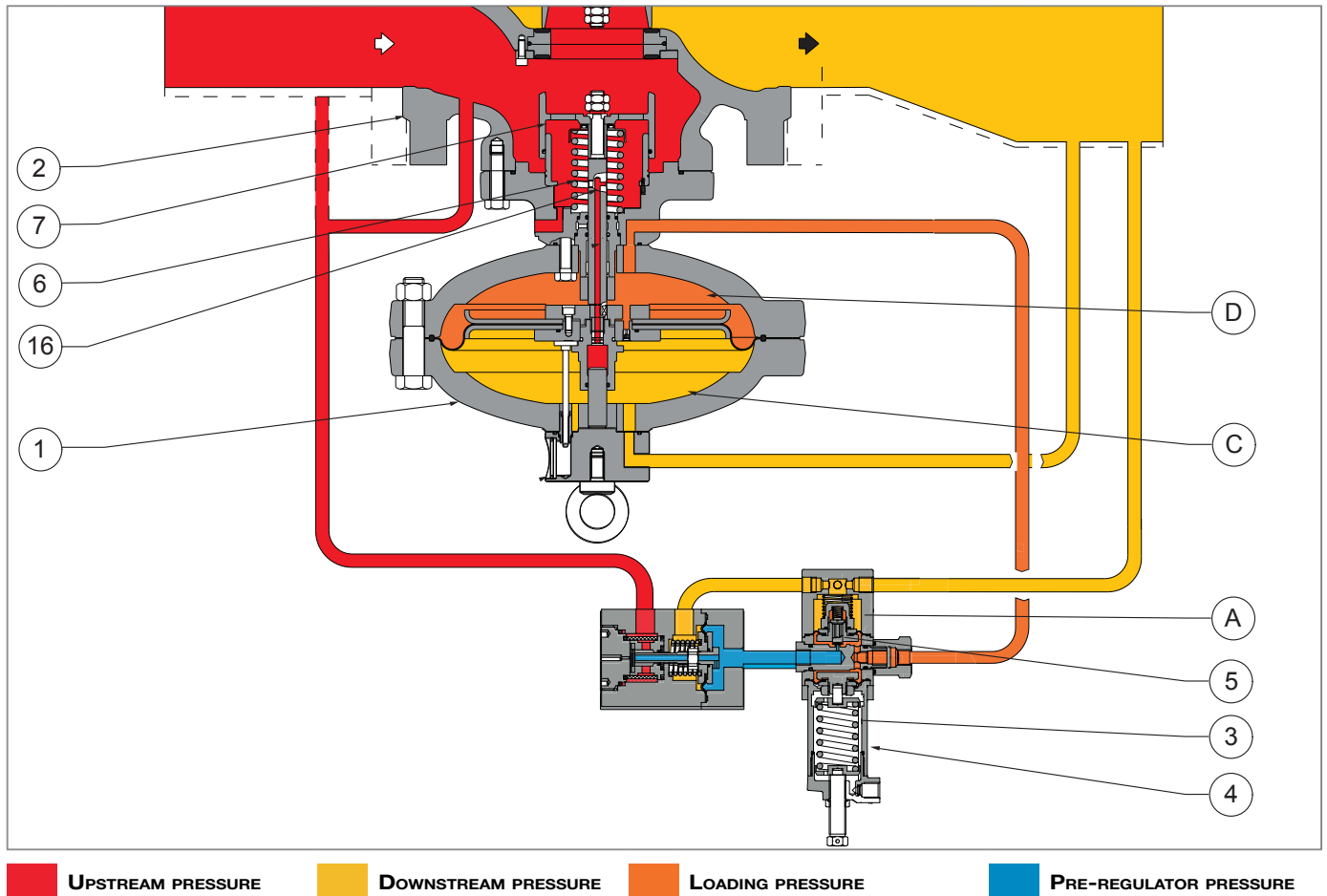

Fig. 4.8. Built-in monitor operation in the event of failure of the main regulator

Should the main regulator (2) fail, the PM/819 monitor (1) will trip until balanced adjustment is achieved. Therefore, should the following occur during operation:

Operating conditions	Operating consequences	Outcome
<b>Decrease in downstream pressure (Pd) due to:</b> <ul style="list-style-type: none"> <li>• rise in the requested flow rate;</li> <li>• decrease in upstream pressure (Up).</li> </ul>	Imbalance between the pressure force in the chamber (A) and the calibration spring (3) of the pilot (4) which causes: <ul style="list-style-type: none"> <li>• increased opening of the pilot (4) plug (5);</li> <li>• consequent increase in the value of the loading pressure (Pm), inside the chamber (D).</li> </ul>	Opening of the main regulator (2) plug (7) until forces between the downstream pressure (Pd) in the chamber (A) and the pilot (4) calibration spring (3) have been balanced again.
<b>Increased downstream pressure (Pd)</b>	Move the plug (7) of the PM/819 monitor (1) to the shut-off position for: <ul style="list-style-type: none"> <li>• the decrease in loading pressure (Pm) due to the transfer of this pressure between the chambers (D) and (C) of the PM/819 monitor (1) through the hole (16);</li> <li>• force applied by the spring (6).</li> </ul>	Return of the downstream pressure (Pd) to the predetermined value and to the balance of forces between the downstream pressure (Pd) in the chamber (A) and the calibration spring (3) of the pilot (4).

Tab. 4.21

#### 4.5.2.1 - M/A ACCELERATING VALVE

**NOTICE!**

**For the monitor to be used as a safety accessory according to “PED” Directive 2014/68/EU, installing the M/A accelerating valve is recommended.**

In the event of a malfunction of the main regulator (1), the M/A accelerating valve (3) is to be installed in order to facilitate the intervention of the built-in monitor PM/819 (2).

The M/A accelerating valve (3), based on a downstream pressure signal ( $P_d$ ), discharges the gas contained in the loading chamber of the monitor, thus enabling more rapid tripping.

Calibration is performed by turning the adjustment screw (4) clockwise or anti-clockwise to increase or decrease the value.

In Tab. 4.22 the operating range of the M/A accelerating valve:

Accelerator valve	Operating range (bar)
M/A	> 0.55

Tab. 4.22.

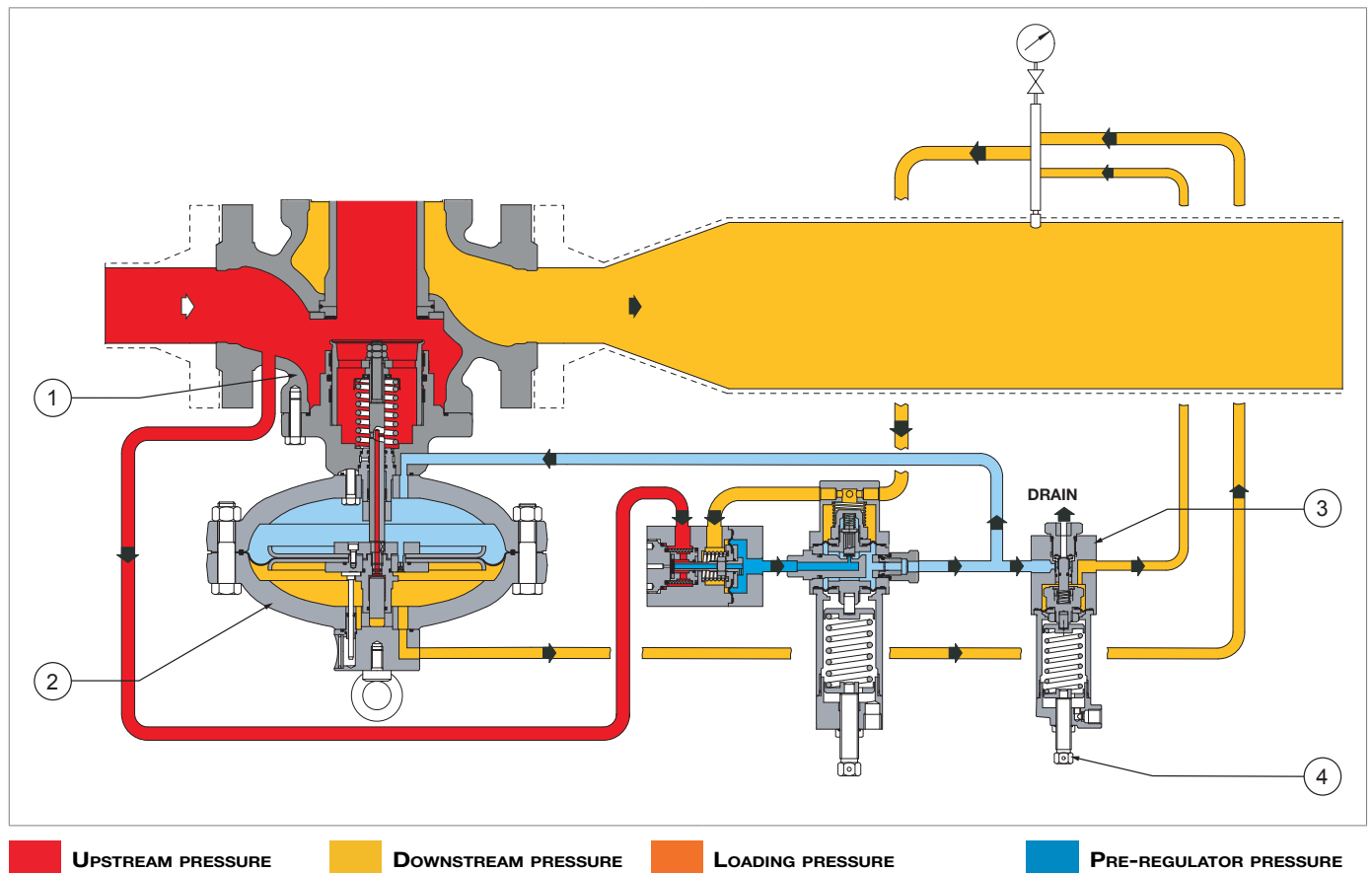

Fig. 4.9. M/A accelerating valve

### 4.5.3 - SLAM-SHUT VALVE

The slam-shut valve is a safety device is used to shut off the gas flow if the pressure value at the control point exceeds the calibration value of the valve itself.

The slam-shut valve is incorporated into the main body of the equipment and consists of:

- a control system;
- the slam-shut device mechanism.

In the event of triggering, the slam-shut valve shuts off power supply to the regulator and its control pilot.

#### 4.5.3.1 - SB/82 BUILT-IN SLAM-SHUT VALVE

The SB/82 built-in slam-shut valve can be operated:

- by the pressure switch;
- manually;
- with remote control (optional).

The main features of the SB/82 built-in slam-shut valve are:

- tripping due to downstream pressure increase and/or decrease;
- design pressure: 100 bar for all accessory components;
- local shut-off button;
- manual reset only with internal bypass activated by the reset lever.

Pressure switch type	Set	Operating range (bar)	AG
<b>Mod. 102M</b>	max	0.2 - 5.5	5
<b>Mod. 103M</b>	max	2 - 7	5
	max	7 - 22	2.5
<b>Mod. 104M</b>	max	15 - 45	2.5
<b>Mod. 105M</b>	max	30 - 90	2.5

Tab. 4.23.

\* For the calibration values of the minimum spring, please refer to chapter 13 'Calibration tables'

The SB/82 incorporated slam-shut valve consists of (see Fig. 4.10):

Pos.	Description
<b>1</b>	Plug
<b>2</b>	Control pressure switch
<b>3</b>	Reset system (manually operated through a lever)

Tab. 4.24

#### OPERATION:

The tripping pressure acts on the control element of the control pressure switch (2), which is solidly connected to the stem (5), and receives an antagonistic force through the springs due to maximum (7) and minimum (6) pressure tripping, calibrated to the pre-set values.

The translation of the stem (5) causes the control device (8) of the mobile system to be released and, through the action of the spring (9), the plug (1) to be shut off.

To reset the device, it is necessary to act on the lever (3) which:

- opens an internal bypass in the first section of the stroke allowing the upstream pressure to be transferred from the inlet chamber to the outlet chamber of the regulator body (4), thereby rebalancing the pressure on the plug (1);
- re-couples the control device (8) of the mobile system.

The release of the control device (8) of the mobile system can also be controlled manually by means of a button (10).

#### NOTICE!

**For the 10" version, bypassing must be performed using the HP2/2 bypass device (Fig. 4.11, ref.11).**

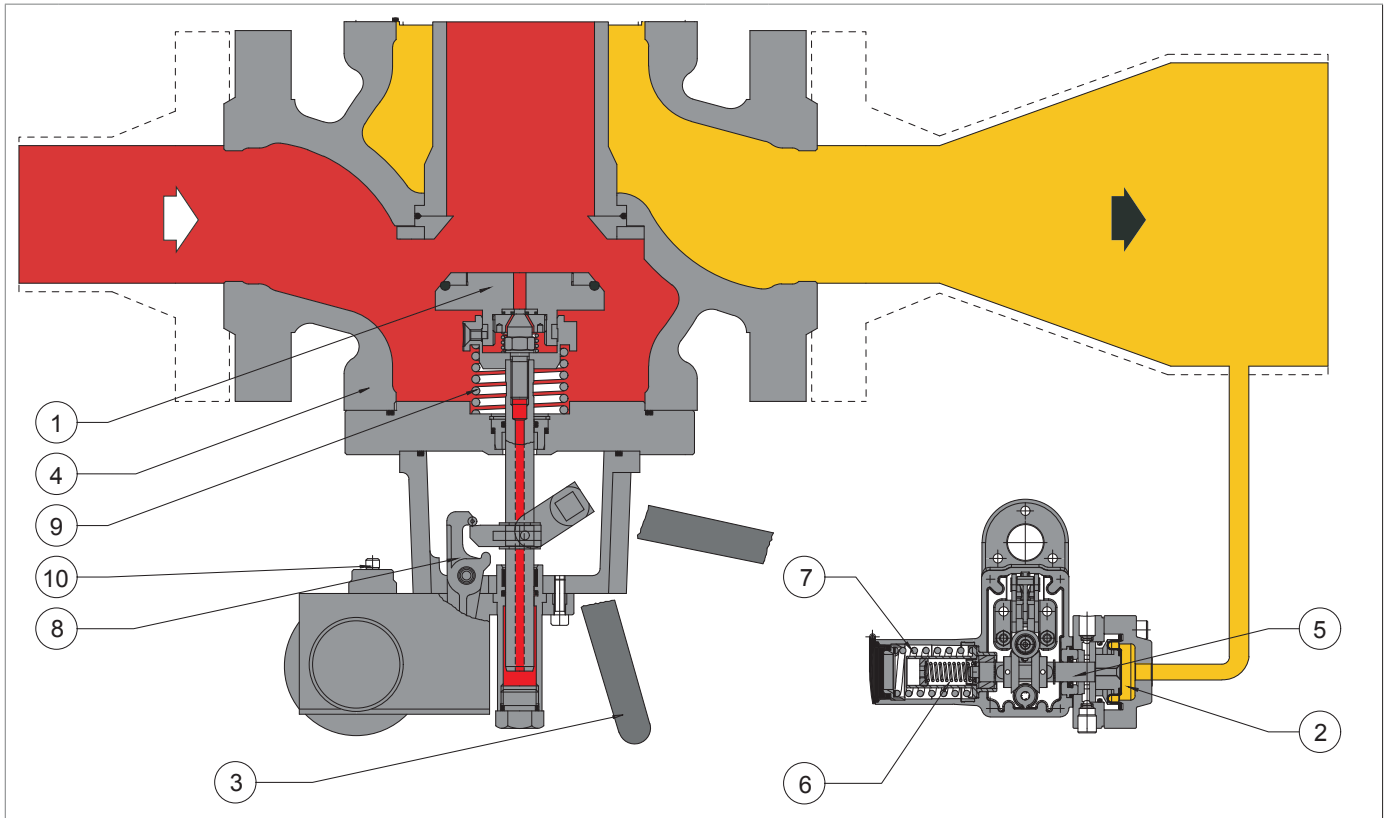

**UPSTREAM PRESSURE**

**DOWNSTREAM PRESSURE**

Fig. 4.10. REFLUX 819/FO with SB/82 incorporated slam-shut valve

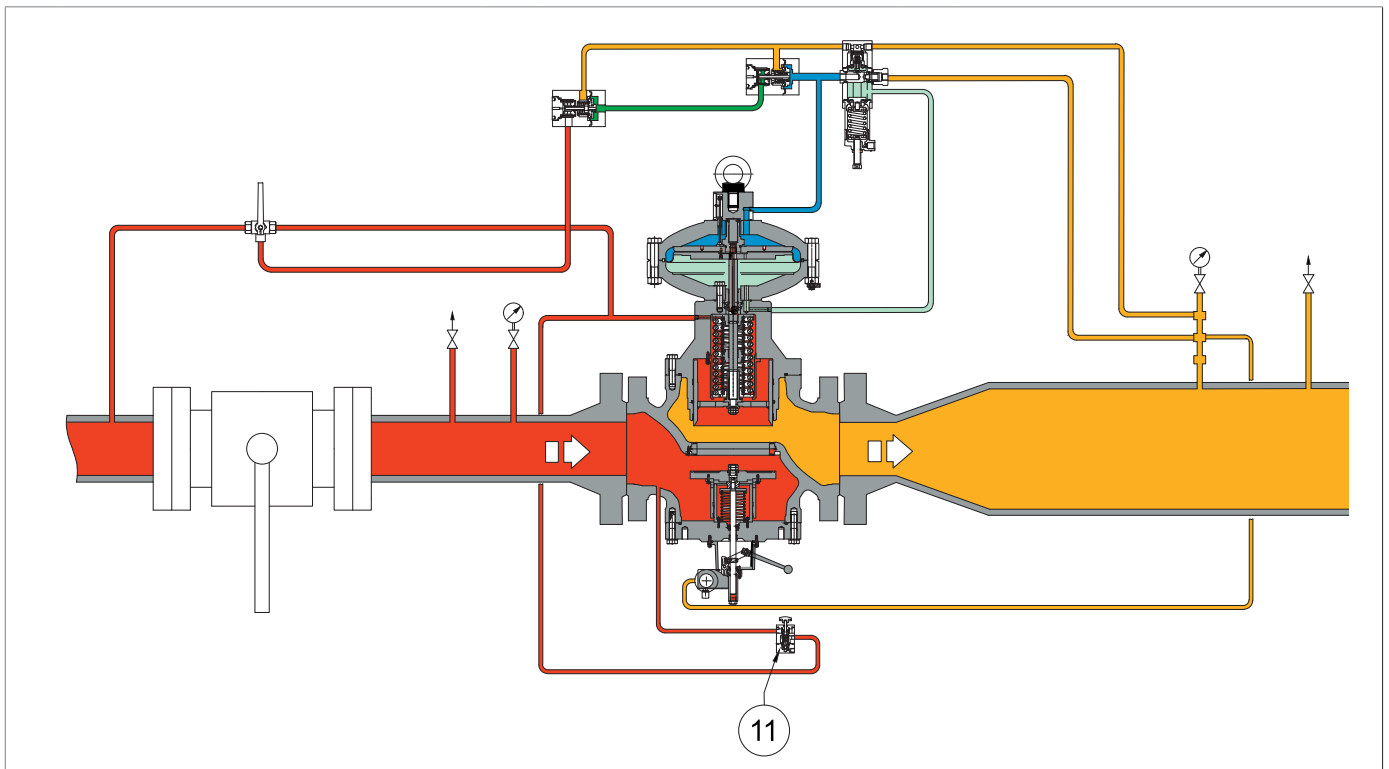

**UPSTREAM PRESSURE**

**DOWNSTREAM PRESSURE**

**LOADING PRESSURE**

Fig. 4.11. HP2/2 bypass detail for incorporated SBC 82 10" slam-shut valve

**REFLUX 819/FO**

#### 4.5.3.2 - HB/97 BUILT-IN SLAM-SHUT VALVE

The built-in HB/97 incorporated slam-shut valve can be operated:

- by the pressure switch;
- manually;
- with remote control.

The main features of the HB/97 built-in slam-shut valve are:

- balanced valve plug;
- local shut-off button;
- tripping due to downstream pressure increase and/or decrease;
- built-in bypass;
- manual resetting only.

Pressure switch type	Set	Operating range (bar)	AG
<b>Mod. 102M</b>	max	0.2 - 5.5	5
<b>Mod. 103M</b>	max	2 - 7	5
	max	7 - 22	2.5
<b>Mod. 104M</b>	max	15 - 45	2.5
<b>Mod. 105M</b>	max	30 - 90	2.5

Tab. 4.25.

\* For the calibration values of the minimum spring, please refer to chapter 13 'Calibration tables'

The HB/97 incorporated slam-shut valve consists of (see Fig. 4.12):

Pos.	Description
<b>1</b>	Balanced valve plug
<b>2</b>	LINE OFF 2.0 device

Tab. 4.26

The LINE OFF 2.0 device (3) consists of (see Fig. 4.12):

Pos.	Description
<b>3</b>	HP2/2: filtering device of the gas supplying the control circuit; it also acts as a bypass necessary for resetting the built-in slam-shut valve HB/97.
<b>4</b>	R44/SS: pressure regulator necessary to decrease the upstream pressure of the regulator to the loading pressure of the HB/97 incorporated slam-shut valve cylinder.
<b>5</b>	AR100: flow throttle valve to adjust the pressure loading speed in the pneumatic circuit and to filter the gas entering the R44/SS regulator (6).
	 <b>NOTICE!</b> <b>The load speed is adjusted by a screw (minimum value 1, maximum value 8).</b>
<b>6</b>	VS/FI: safety valve used to: <ul style="list-style-type: none"> <li>• discharge any overpressure generated by malfunction of the R44/SS pressure regulator into the atmosphere;</li> <li>• protect the entire circuit downstream of the R44/SS pressure regulator.</li> </ul>
<b>7</b>	3/2 valve used to pressurise and depressurise the cylinder of the HB/97 incorporated slam-shut valve.
<b>8</b>	Control pressure switch: through the control pressure switch head connected downstream, the HB/97 built-in slam-shut valve trips due to increased or decreased downstream pressure.

Tab. 4.27

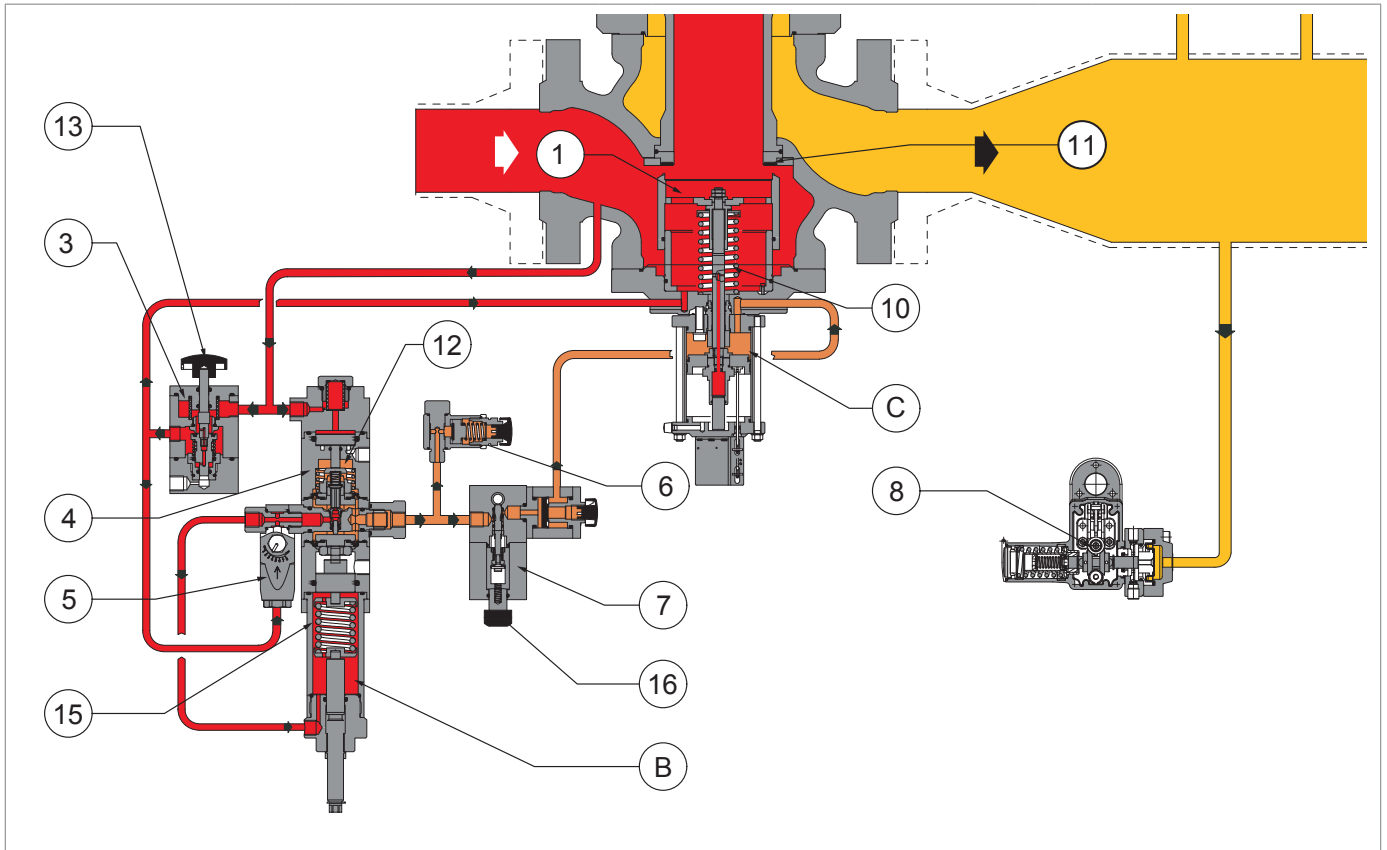

Fig. 4.12. REFLUX 819/FO with HB/97 incorporated slam-shut valve

### OPERATION:

At no pressure, the valve plug (1) is kept in the shut-off position by the spring (10) and rests on the reinforced gasket (11).

The upstream pressure ( $U_p$ ) reaches the HP2/2 bypass device (3) and the upper head (12) of the R44/SS regulator (4) to prevent inappropriate resetting of the valve. By adjusting the activation button (13) of the bypass, the pressurised gas is filtered and feeds the AR100 throttle valve (5), which in turn supplies:

- the chamber of the adjustment spring (B);
- the upstream of the R44/SS regulator (5), calibrated at a pressure of 4.5 bar to overcome the force of the closing spring (15) of the slam-shut valve.

Pressing the reset button (16) acts on the pressure switch coupling (8), so that the 3/2 valve (8) can be opened:

- pressurisation of the chamber (C) of the slam-shut valve by the R44/SS regulator (4);
- the plug opening (1).

In the event that the downstream pressure ( $P_d$ ) increases or decreases, the pressure switch coupling (8) moves to:

- discharge the pressure from the chamber (C) into the atmosphere through the 3/2 valve (7);
- allow the spring (10) to bring the plug (1) to the shut-off position.

#### 4.5.4 - SLAM-SHUT VALVE PRESSURE SWITCHES

The pressure switch is a control device consisting of (see Fig. 4.13):

Pos.	Description
1	Control element. <b>NOTICE!</b> <b>The control element can be a diaphragm or a piston.</b>
2	Stem.
3-4	Adjustment feeler gauges.
5	Spring for maximum pressure tripping.
6	Spring for minimum pressure tripping.
7	OPSO maximum spring adjustment nuts (5).
8	UPSO minimum spring adjustment nuts (6).
10	Manual release button.

Tab. 4.28

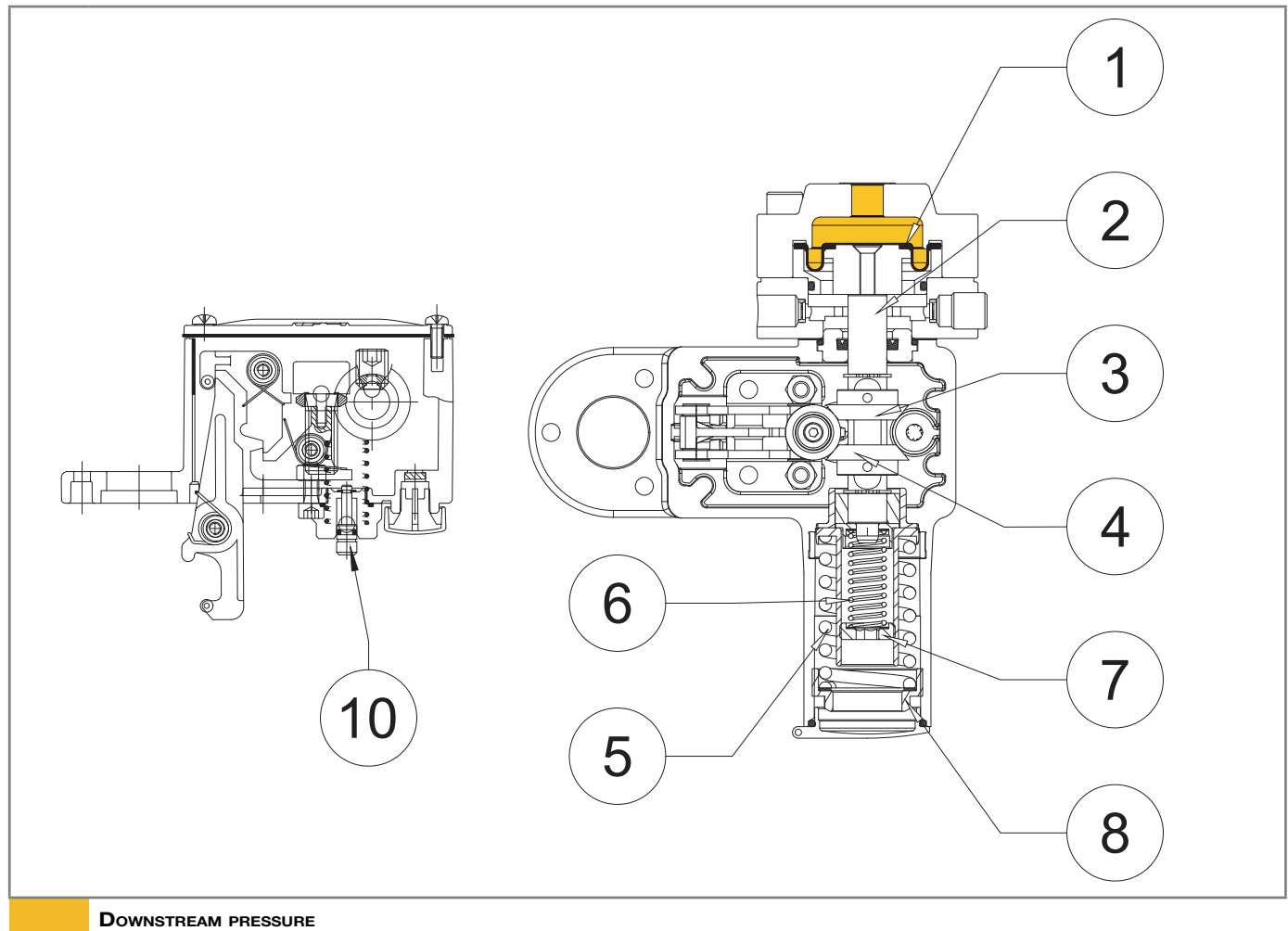

Fig. 4.13.

Slam-shut device pressure switch

Tab. 4.29 lists the models of possible pressure switches for this regulator:

<b>Model pressure switch</b>	<b>Max [bar]</b>	<b>Min [bar]</b>
<b>102M</b>	0.2 - 5.5	0.05 - 2.8
<b>102MH</b>	0.2 - 5.5	2.8 - 5.5
<b>103M</b>	2 - 22	0.2 - 8
<b>103MH</b>	2 - 22	8 - 19
<b>104M</b>	15 - 45	1.6 - 18
<b>104MH</b>	15 - 45	18 - 41
<b>105M</b>	30 - 90	3 - 44
<b>105MH</b>	30 - 90	44 - 90

*Tab. 4.29*

PAGE INTENTIONALLY LEFT BLANK

## 5 - TRANSPORT AND HANDLING

### 5.1 - SPECIFIC WARNINGS FOR TRANSPORT AND HANDLING

#### NOTICE!

Transport and handling must be carried out by personnel:

- qualified (specially trained);
- who are familiar with accident prevention and workplace safety regulations;
- authorised to use lifting equipment and means;
- in compliance with the regulations in force in the country of destination of the equipment.

#### Transport with forklift or crane

<b>Operator qualification</b>	Person in charge of transport, handling, unloading and placing on site
<b>PPE required</b>	 <p><b>WARNING!</b></p> <p>The PPE listed in this table is related to the risk associated with the equipment. For the required PPE to protect against risks associated with the workplace, installation or operating conditions, please refer to:</p> <ul style="list-style-type: none"> <li>• the regulations in force in the country of installation;</li> <li>• <u>any information provided by the Safety Manager at the installation facility.</u></li> </ul>
<b>Means of lifting</b>	Hoist crane, forklift truck or other suitable equipment.
<b>Weights and dimensions of the equipment</b>	For dimensions and weights please refer to “5.2 - Physical characteristics of the equipment”.

Tab. 5.30

### 5.1.1 - PACKAGING AND FASTENERS USED FOR TRANSPORT

The transport packaging has been designed and manufactured to avoid damage during normal transport, storage and handling.

The equipment and spare parts must be kept in their packaging until they are installed.



Upon receiving the equipment:

- make sure that no part of the packaging has been damaged during transport and/or handling;
- immediately report any damage found to PIETRO FIORENTINI S.p.A..

**! NOTICE!**

**PIETRO FIORENTINI S.p.A. shall not be liable for any damage to people or property caused by accidents due to failure to comply with the instructions provided in this manual.**

Tab. 5.31 shows the types of packaging used:

Ref.	Type of packaging	Image
A	Cardboard box	
B	Wooden box	
C	Pallet	

Tab. 5.31

PAGE INTENTIONALLY LEFT BLANK

**5.2 - PHYSICAL CHARACTERISTICS OF THE EQUIPMENT**

**5.2.1 - REFLUX 819/FO (+LDB/171)**

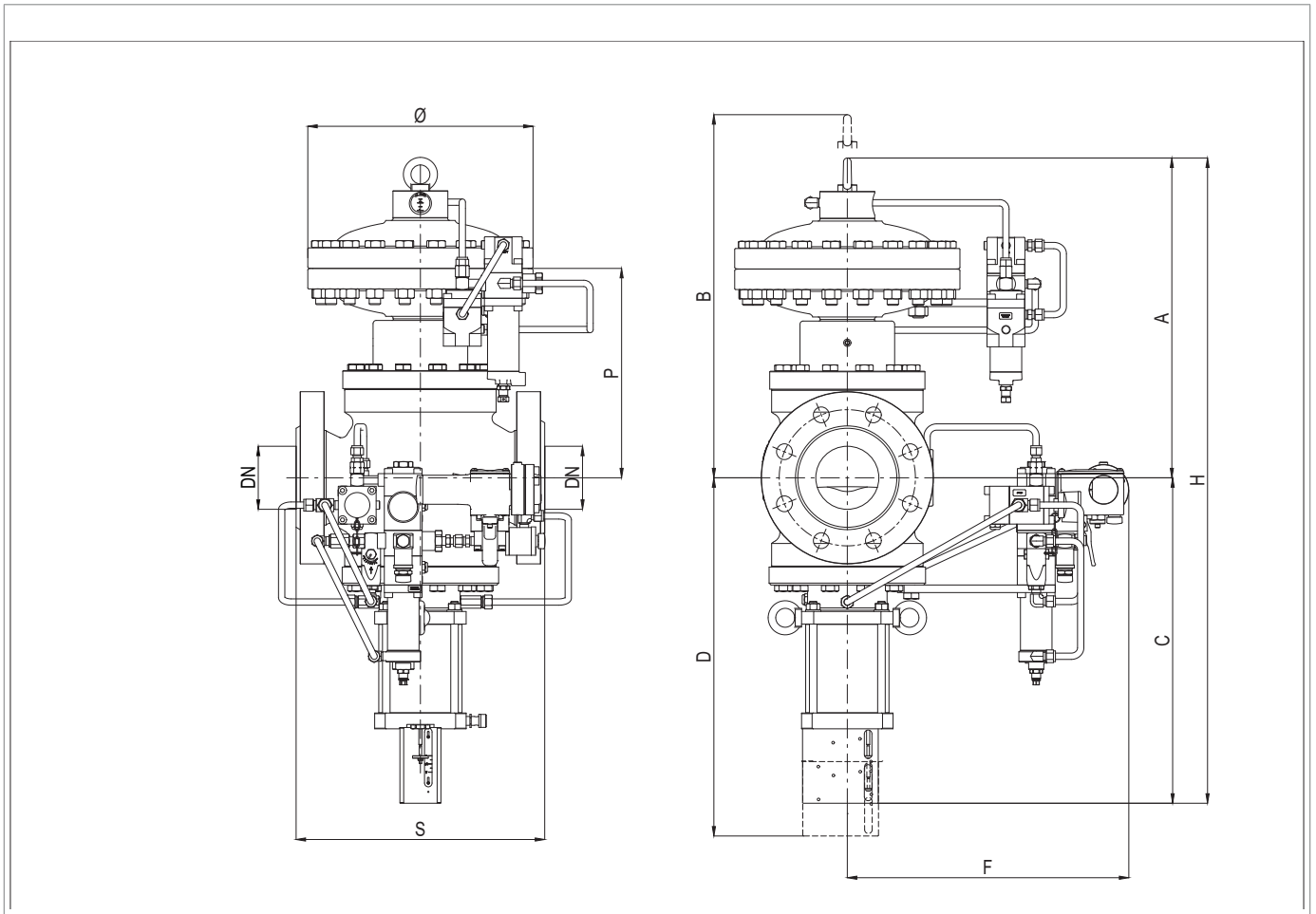

Fig. 5.14. Physical characteristics REFLUX 819/FO (+LDB/171)

Overall dimensions REFLUX 819/FO (+LDB/171)								
Nominal diameter [mm]	25	50	80	100	150	200	250	300
Size [inches]	1"	2"	3"	4"	6"	8"	10"	12"
<b>S - Ansi 150/PN 16</b>	184	254	298	352	451	543	673	737
<b>S - Ansi 300</b>	197	267	317	368	473	568	708	775
<b>S - Ansi 600</b>	210	286	336	394	508	609	752	819
<b>Ø</b>	278	278	360	360	510	510	610	718
<b>A</b>	371	435	490	532	789	750	1075	1060
<b>B</b>	461	515	590	642	874	460	1175	1330
<b>C</b>	100	130	150	190	225	265	340	375
<b>D</b>	130	160	200	250	275	420	440	475
<b>F</b>	310	310	320	320	420	460	470	500
<b>G</b>	311	375	410	422	549	1015	847	780
<b>H</b>	471	560	640	722	1014	370	1515	1435
<b>P</b>	220	285	320	332	459	460	775	762
<b>Pneumatic connections</b>	Øe 10mm x Øi 8mm							

Tab. 5.32

Weights [kgf]								
<b>Ansi 150/PN 16</b>	44	61	105	146	308	408	900	1433
<b>Ansi 300</b>	45	62	109	156	345	470	950	1450
<b>Ansi 600</b>	46	64	112	165	360	495	1000	1530

Tab. 5.33

**5.2.2 - REFLUX 819/FO + DB/819**

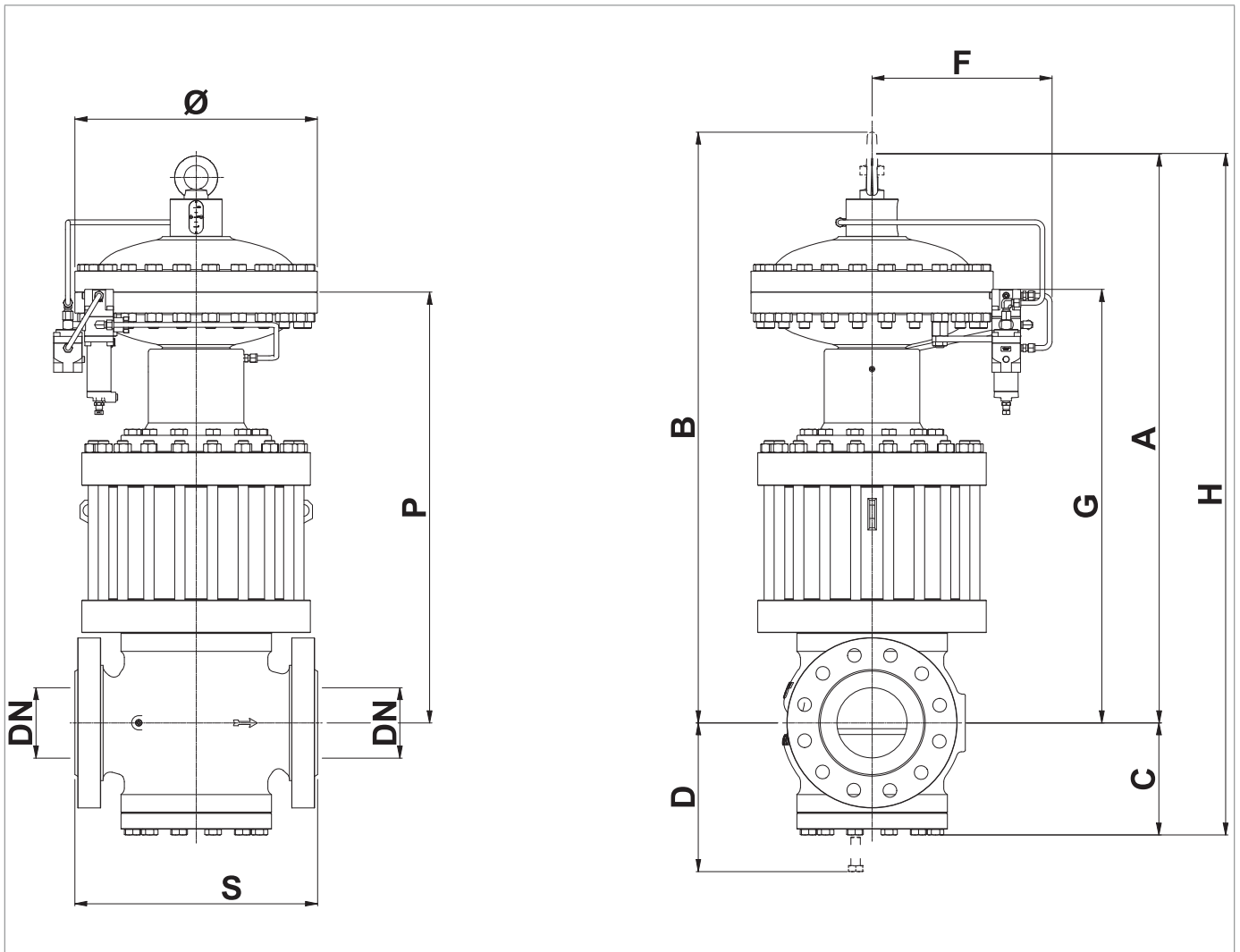

Fig. 5.15. REFLUX 819/FO + DB/819 physical characteristics

REFLUX 819/FO + DB/819 overall dimensions								
Nominal diameter [mm]	25	50	80	100	150	200	250	300
Size [inches]	1"	2"	3"	4"	6"	8"	10"	12"
<b>S - Ansi 150/PN 16</b>	184	254	298	352	451	543	673	737
<b>S - Ansi 300</b>	197	267	317	368	473	568	708	775
<b>S - Ansi 600</b>	210	286	336	394	508	609	752	819
<b>Ø</b>	278	278	360	360	510	510	610	718
<b>A</b>	571	660	760	842	1074	1222	1575	1640
<b>B</b>	661	725	505	937	1259	1387	1775	1905
<b>C</b>	100	130	150	190	225	265	340	375
<b>D</b>	130	160	200	250	275	320	440	475
<b>F</b>	310	310	320	320	420	420	470	500
<b>G</b>	476	580	675	812	394	1032	1375	1355
<b>H</b>	671	790	845	1032	1299	1487	1915	2015
<b>P</b>	220	300	330	390	480	595	695	745
<b>K</b>	421	485	565	627	829	907	1275	1337
<b>Pneumatic connections</b>	Øe 10mm x Øi 8mm							

Tab. 5.34

Weights [kgf]								
<b>Ansi 150/PN 16</b>	70	126	195	260	565	835	1280	2091
<b>Ansi 300</b>	72	128	204	289	608	925	1380	2286
<b>Ansi 600</b>	73	130	207	298	640	950	1430	2366

Tab. 5.35

5.2.3 - REFLUX 819/FO + PM/819

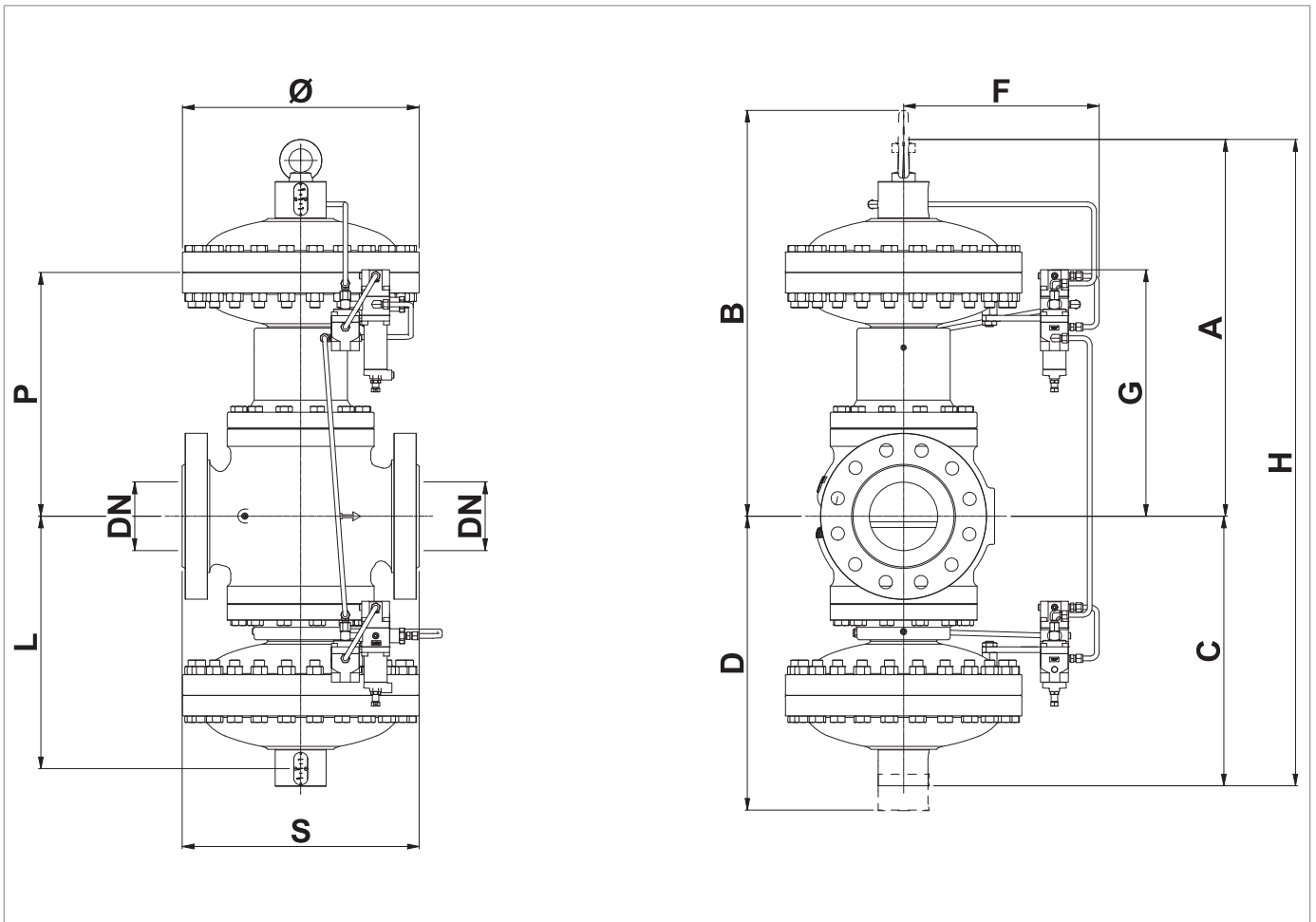

Fig. 5.16. REFLUX 819/FO + PM/819 physical characteristics

**REFLUX 819/FO + PM/819 overall dimensions**

<b>Nominal diameter [mm]</b>	25	50	80	100	150	200	250
<b>Size [inches]</b>	1"	2"	3"	4"	6"	8"	10"
<b>S - Ansi 150/PN 16</b>	184	254	298	352	451	543	673
<b>S - Ansi 300</b>	197	267	317	368	473	568	708
<b>S - Ansi 600</b>	210	286	336	394	508	609	752
<b>Ø</b>	278	278	360	360	510	510	610
<b>A</b>	371	435	490	532	789	887	1075
<b>B</b>	461	515	590	642	874	967	500
<b>C</b>	320	350	430	490	650	750	800
<b>D</b>	410	430	530	600	735	850	900
<b>F</b>	310	310	320	320	420	420	470
<b>G</b>	311	375	410	422	459	597	847
<b>H</b>	691	785	920	1022	1439	1637	1175
<b>L</b>	170	200	260	290	320	370	500
<b>P</b>	221	285	320	332	459	507	847
<b>Pneumatic connections</b>	Øe 10mm x Øi 8mm						

*Tab. 5.36*
**Weights [kgf]**

<b>Ansi 150/PN 16</b>	84	105	180	245	517	670	1400
<b>Ansi 300</b>	85	106	184	255	554	731	1450
<b>Ansi 600</b>	86	108	187	264	569	756	1500

*Tab. 5.37*

5.2.4 - REFLUX 819/FO + SB/82

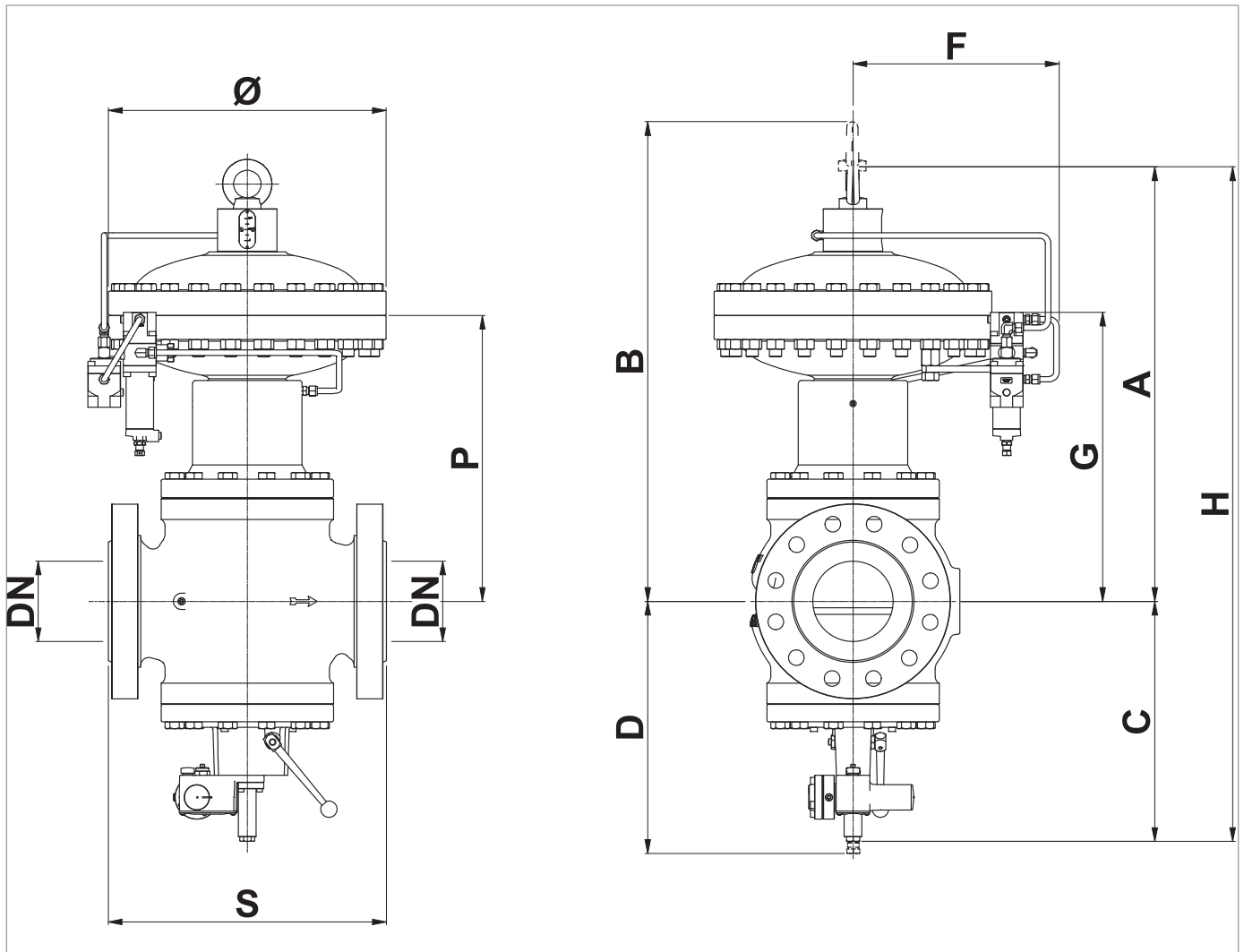

Fig. 5.17. Physical characteristics REFLUX 819/FO + SB/82

Overall dimensions REFLUX 819/FO + SB/82							
<b>Nominal diameter [mm]</b>	25	50	80	100	150	200	250
<b>Size [inches]</b>	1"	2"	3"	4"	6"	8"	10"
<b>S - Ansi 150/PN 16</b>	184	254	298	352	451	543	673
<b>S - Ansi 300</b>	197	267	317	368	473	568	708
<b>S - Ansi 600</b>	210	286	336	394	508	609	752
<b>Ø</b>	278	278	360	360	510	510	610
<b>A</b>	371	435	490	532	789	887	1075
<b>B</b>	461	515	590	642	874	987	1147
<b>C</b>	215	240	270	300	375	450	530
<b>D</b>	290	330	380	440	560	625	730
<b>F</b>	310	310	320	320	420	420	470
<b>G</b>	311	375	410	422	549	597	847
<b>H</b>	471	675	760	832	1164	1337	1515
<b>P</b>	221	285	320	332	459	507	775
<b>Pneumatic connections</b>	Øe 10mm x Øi 8mm						

Tab. 5.38

Weights [kgf]							
<b>Ansi 150/PN 16</b>	53	71	115	160	320	460	950
<b>Ansi 300</b>	55	73	122	171	365	525	1000
<b>Ansi 600</b>	56	75	125	180	380	550	1050

Tab. 5.39

**5.2.5 - REFLUX 819/FO + HB/97**

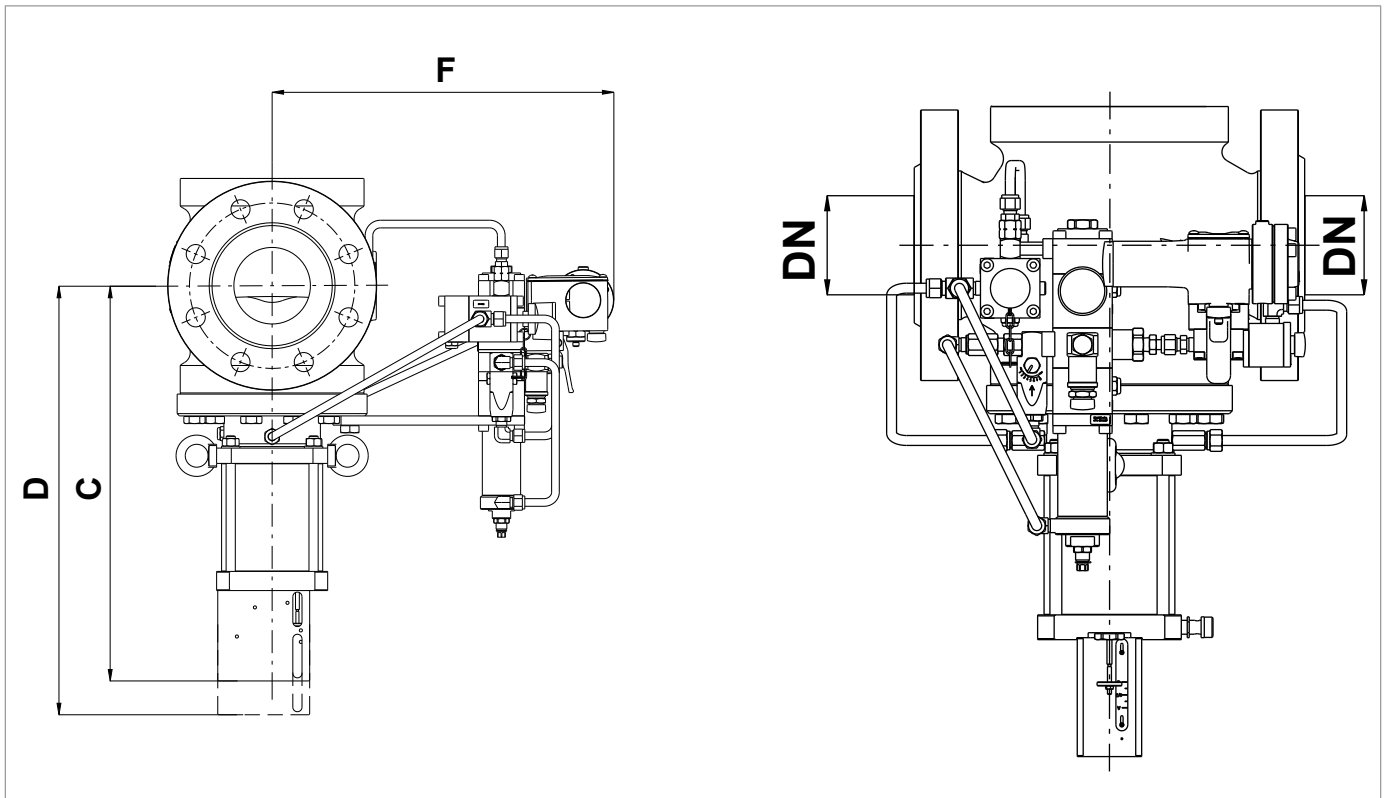

Fig. 5.18. Physical characteristics REFLUX 819/FO + HB/97

**Overall dimensions REFLUX 819/FO + HB/97**

Nominal diameter [mm]	100	150	200	250	300
Size [inches]	4"	6"	8"	10"	12"
<b>S - Ansi 150/PN 16</b>	352	451	543	673	737
<b>S - Ansi 300</b>	368	473	568	708	775
<b>S - Ansi 600</b>	394	508	609	752	819
<b>Ø</b>	-	-	900	-	718
<b>A</b>	532	789	887	1075	1060
<b>B</b>	642	874	987	1147	1330
<b>C</b>	518	645	687	796	940
<b>D</b>	650	835	445	1060	-
<b>F</b>	358	410	-	510	530
<b>G</b>	422	549	597	847	780
<b>H</b>	832	1164	1337	1515	2000
<b>P</b>	332	459	507	775	762
<b>Pneumatic connections</b>	Øe 10mm x Øi 8mm				

*Tab. 5.40*
**Weights [kgf]**

<b>Ansi 150/PN 16</b>	150	310	414	894	1655
<b>Ansi 300</b>	230	424	599	1090	1730
<b>Ansi 600</b>	276	476	684	1200	1810

*Tab. 5.41*

**5.2.6 - REFLUX 819/FO + DB/819 + PM/819**

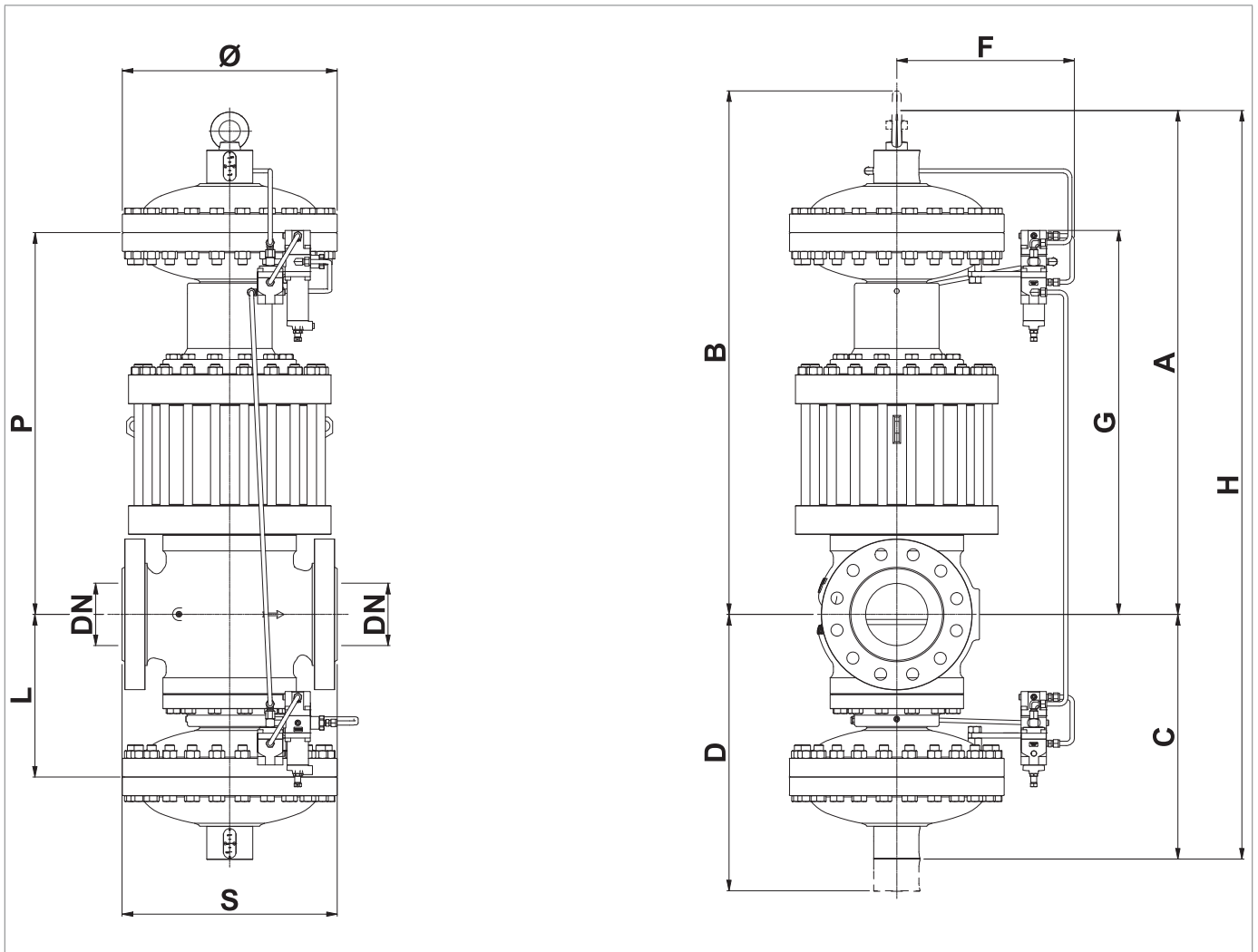

Fig. 5.19. REFLUX 819/FO + DB/819 + PM/819 physical characteristics

**REFLUX 819/FO + DB/819 + PM/819 overall dimensions**

<b>Nominal diameter [mm]</b>	25	50	80	100	150	200	250
<b>Size [inches]</b>	1"	2"	3"	4"	6"	8"	10"
<b>S - Ansi 150/PN 16</b>	184	254	298	352	451	543	673
<b>S - Ansi 300</b>	197	267	317	368	473	568	708
<b>S - Ansi 600</b>	210	286	336	394	508	609	752
<b>Ø</b>	278	278	360	360	510	510	610
<b>A</b>	571	660	760	842	1074	1222	1575
<b>B</b>	661	725	845	937	1259	1387	1775
<b>C</b>	320	350	430	490	650	750	800
<b>D</b>	410	430	530	600	735	850	900
<b>F</b>	310	310	320	320	420	420	470
<b>G</b>	476	580	675	812	934	1032	1375
<b>H</b>	891	1010	1195	1332	1724	1972	2375
<b>K</b>	220	300	330	390	480	595	695
<b>L</b>	221	200	260	290	320	370	500
<b>P</b>	421	485	320	617	827	907	1275
<b>Pneumatic connections</b>	Øe 10mm x Øi 8mm						

*Tab. 5.42*
**Weights [kgf]**

<b>Ansi 150/PN 16</b>	110	170	270	359	774	1097	1780
<b>Ansi 300</b>	112	172	267	388	783	1185	1880
<b>Ansi 600</b>	113	174	270	397	815	1210	1930

*Tab. 5.43*

**5.2.7 - REFLUX 819/FO + DB/819 + SB/82**

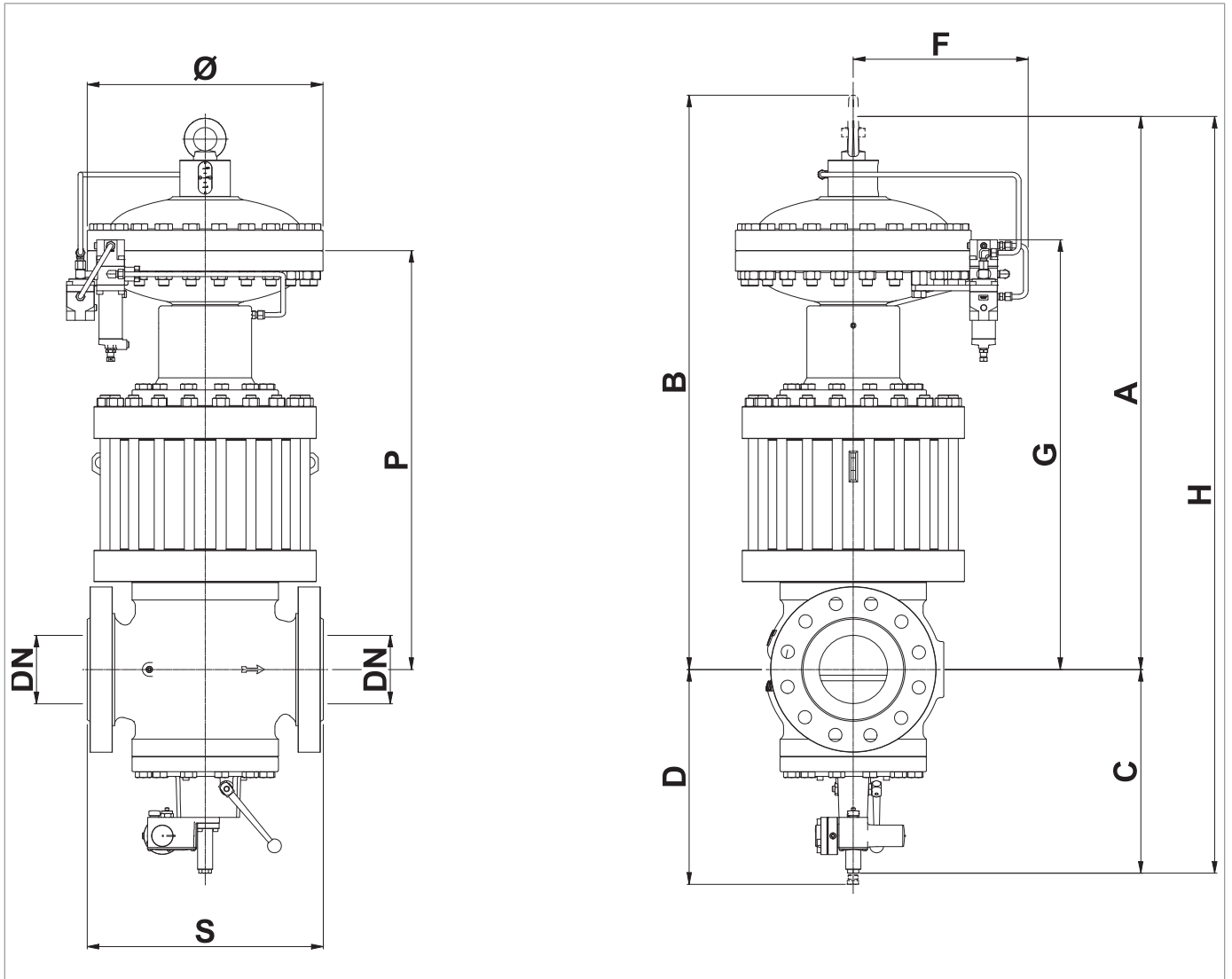

Fig. 5.20. Physical characteristics REFLUX 819/FO + DB/819 + SB/82

**Overall dimensions REFLUX 819/FO + DB/819 + SB/82**

<b>Nominal diameter [mm]</b>	25	50	80	100	150	200	250
<b>Size [inches]</b>	1"	2"	3"	4"	6"	8"	10"
<b>S - Ansi 150/PN 16</b>	184	254	298	352	451	543	673
<b>S - Ansi 300</b>	197	267	317	368	473	568	708
<b>S - Ansi 600</b>	210	286	336	394	508	609	752
<b>Ø</b>	278	278	360	360	510	510	610
<b>A</b>	571	660	760	842	1074	1222	1575
<b>B</b>	661	725	845	937	1259	1387	1775
<b>C</b>	215	240	270	300	375	450	530
<b>D</b>	280	330	380	440	560	625	730
<b>F</b>	310	310	320	320	420	420	470
<b>G</b>	476	580	675	812	934	1032	1375
<b>H</b>	796	900	1030	1142	1449	1672	2105
<b>K</b>	220	300	330	390	480	595	695
<b>P</b>	421	485	565	617	827	907	1275
<b>Pneumatic connections</b>	Øe 10mm x Øi 8mm						

*Tab. 5.44*
**Weights [kgf]**

<b>Ansi 150/PN 16</b>	79	136	205	274	577	887	1330
<b>Ansi 300</b>	82	139	217	304	628	980	1430
<b>Ansi 600</b>	83	141	220	313	660	1500	<b>1480</b>

*Tab. 5.45*

**5.2.8 - REFLUX 819/FO + DB/819 + HB/97**

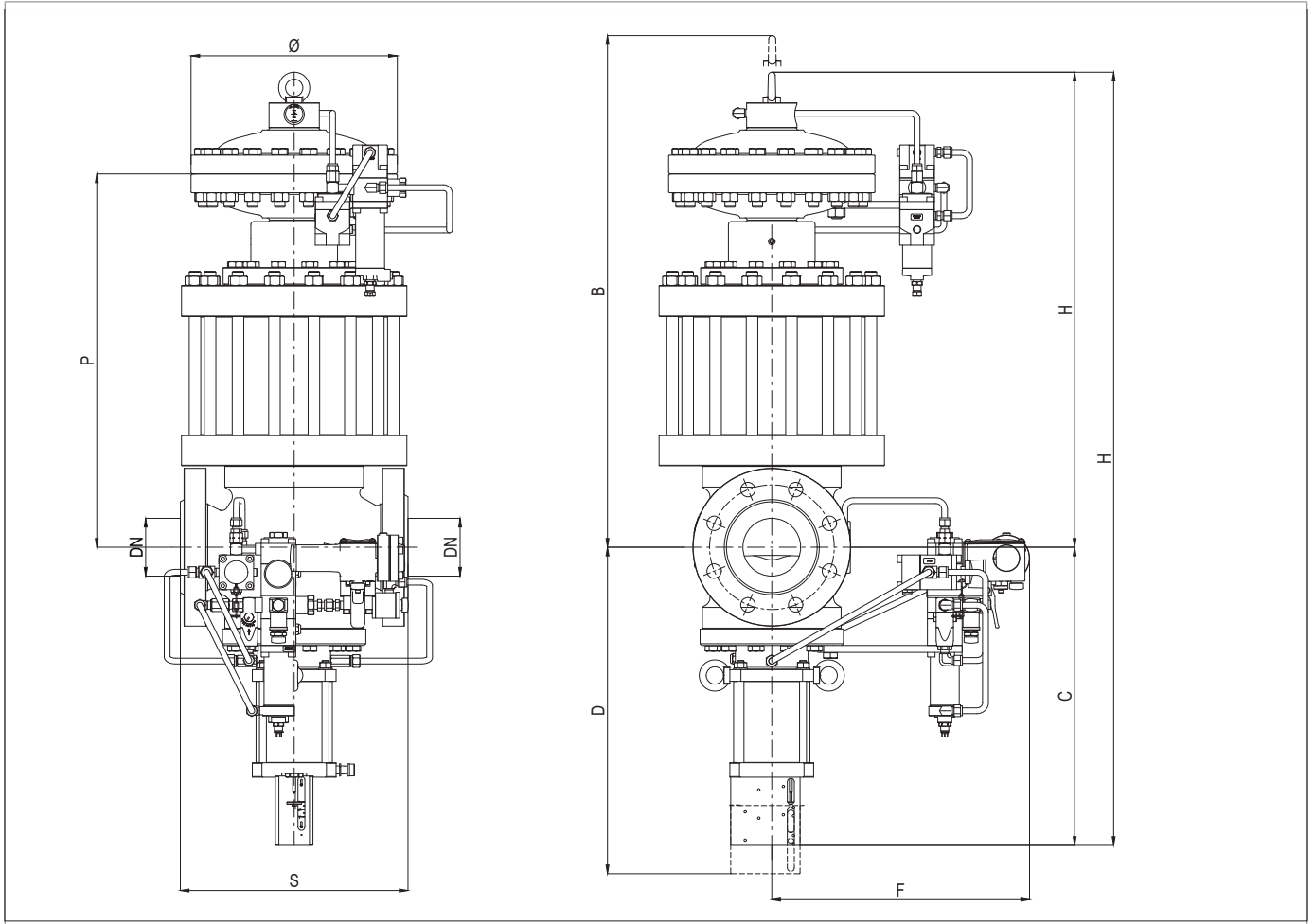

Fig. 5.21. Physical characteristics REFLUX 819/FO + DB/819 + HB/97

**Overall dimensions REFLUX 819/FO + DB/819 + HB/97**

Nominal diameter [mm]	100	150	200	250	300
Size [inches]	4"	6"	8"	10"	12"
<b>S - Ansi 150/PN 16</b>	352	451	543	673	737
<b>S - Ansi 300</b>	368	473	568	708	775
<b>S - Ansi 600</b>	394	508	609	752	819
<b>Ø</b>	360	510	510	610	718
<b>A</b>	842	1074	1222	1575	1640
<b>B</b>	937	1259	1387	1775	1905
<b>C</b>	518	645	687	796	940
<b>D</b>	650	835	900	1060	1250
<b>F</b>	358	410	445	510	530
<b>G</b>	812	934	1032	1375	1355
<b>H</b>	1142	1449	1672	2105	2580
<b>K</b>	390	480	595	695	745
<b>P</b>	617	827	907	1275	1337
<b>Pneumatic connections</b>	Øe 10mm x Øi 8mm				

*Tab. 5.46*
**Weights [kgf]**

<b>Ansi 150/PN 16</b>	266	569	569	569	2371
<b>Ansi 300</b>	318	661	1006	687	2560
<b>Ansi 600</b>	330	687	1022	756	2646

*Tab. 5.47*

### 5.3 - EQUIPMENT ANCHORING AND LIFTING METHOD

 **HAZARD!**

Before handling the equipment, make sure that the capacity of the lifting equipment is suitable for the load.

 **WARNING!**

Unloading, transport and handling activities must be carried out by operators qualified and specially trained:

- on accident prevention rules;
- on maximum safety in the workplace;
- on the use of lifting equipment.

 **ATTENTION!**

Before handling the equipment:

- remove any movable or hanging component or firmly secure it to the load;
- protect the most fragile equipment;
- check that the load is stable.

### 5.3.1 - FORKLIFT HANDLING METHOD

**HAZARD!**

It is forbidden to:

- transit under suspended loads;
- move the load over the personnel operating in the site/plant area.

**WARNING!**



The following is not allowed on forklifts:

- carrying passengers;
- lifting people.

**NOTICE!**

Packaging must be always handled in a vertical position

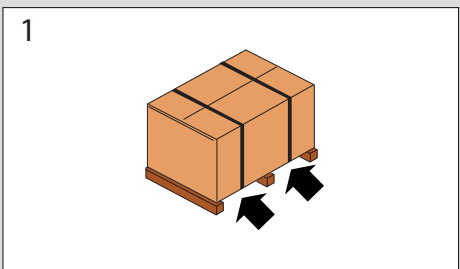
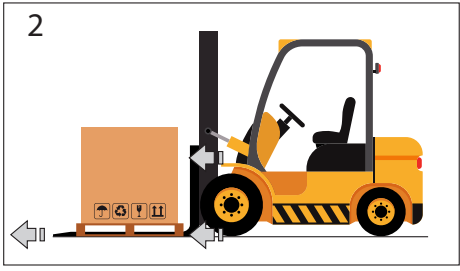
Proceed as described at Tab. 5.48:

Step	Action	Image
1	Place the forks of the forklift under the load surface.	
2	Make sure that the forks protrude from the front of the load (by at least 5 cm), far enough to eliminate any risk of the transported load tipping.	
3	Raise the forks until they are touching the load. <b>NOTICE!</b> <b>Fasten the load to the forks with clamps or similar devices if required.</b>	
4	Slowly lift the load by a few dozen centimetres and check its stability, making sure that the centre of gravity of the load is at the centre of the lifting forks.	

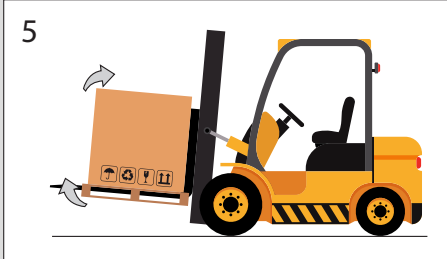
Step	Action	Image
5	Tilt the mast backwards (towards the driver's seat) to help the over-turning moment and to ensure greater load stability during transport.	
6	Adjust transport speed according to the type of floor and load, avoiding jerky movements. <b>⚠ WARNING!</b> <b>If:</b> <ul style="list-style-type: none"> <li>• <b>obstacles along the path;</b></li> <li>• <b>particular operating situations;</b></li> </ul> <b>hinder operator visibility, the assistance of a ground operator is required, standing outside the range of action of the lifting equipment, with the task of signalling.</b>	-
7	Place the load in the chosen installation area.	-

Tab. 5.48

### 5.3.2 - CRANE HANDLING METHOD

**⚠ WARNING!**

CE-marked chains, ropes and eyebolts must be used. Do not use chains connected to each other by bolts. Always check that:

- the safety catch of the hook returns to the initial position;
- the ropes are in excellent condition and have adequate sections.

It is forbidden to:

- drag the load on the ground;
- operate near power lines;
- stand within the range of action of the crane.

**⚠ NOTICE!**

**Packaging must be always handled in a vertical position.**

The equipment must be handled using the lifting points provided on the equipment itself. For proper transport, follow the procedure in Tab. 5.49:

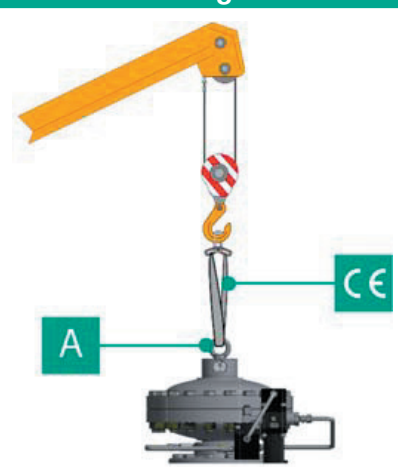
Step	Action	Image
1	Attach the lifting rope or chain to the appropriate supports (A). <b>⚠ WARNING!</b> <b>The lifting point is sized for lifting only the equipment, and not other parts of the system connected to it.</b>	
2	Slightly lift the load making sure the ropes or chains are secure. <b>⚠ NOTICE!</b> <b>Check whether the load is properly balanced.</b>	
3	Handle the load avoiding sudden movements.	
4	Place the load in the chosen installation area.	

Tab. 5.49

## 5.4 - PACKAGING REMOVAL

Packaging removal	
<b>Operator qualification</b>	<ul style="list-style-type: none"> <li>Person in charge of transport, handling, unloading and placing on site;</li> <li>Installer.</li> </ul>
<b>PPE required</b>	<div style="display: flex; align-items: center;">  </div> <div style="background-color: #f4a460; padding: 5px; margin-top: 5px;"> <b>⚠ WARNING!</b> </div> <p>The PPE listed in this table is related to the risk associated with the equipment. For the PPE necessary to protect against risks associated with the workplace or operating conditions, please refer to:</p> <ul style="list-style-type: none"> <li>the regulations in force in the country of installation;</li> <li><u>any information provided by the Safety Manager at the installation facility.</u></li> </ul>

Tab. 5.50

To unpack the equipment in a cardboard box, proceed as described in Tab. 5.51:

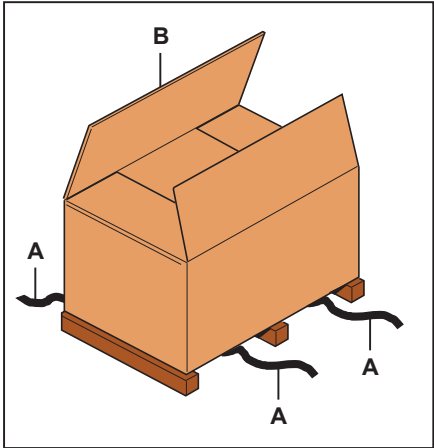
Step	Action	Image
1	Remove the straps (A).	
2	Remove the packaging cardboard (B).	
3	Remove the fasteners that secure the equipment to the base (if any).	
4	Move the equipment from the base to the place intended for it. <div style="border: 1px solid blue; padding: 5px; margin-top: 5px;"> <b>⚠ NOTICE!</b>  <b>Have at least 2 operators manually move the equipment, if required due to its dimensions/weight.</b> </div>	

Tab. 5.51

### ⚠ NOTICE!

After removing all packaging materials, check for any anomalies.

If there are anomalies:

- do not install the equipment;
- contact PIETRO FIORENTINI S.p.A. and specify the details provided on the equipment rating plate.

### 5.4.1 - PACKAGING DISPOSAL

### ⚠ NOTICE!

Sort the various materials making up the packaging and dispose of them in compliance with the regulations in force in the country of installation.

## 5.5 - STORAGE AND ENVIRONMENTAL CONDITIONS

If the equipment needs to be stored for an extended period, the minimum environmental conditions for the intended storage are provided. Only by complying with these requirements can the declared performance be guaranteed:

Conditions	Data
Maximum storage period	Maximum 3 years. <div style="border: 1px solid black; padding: 5px;">  <b>NOTICE!</b>  <b>For installations in later periods, see paragraph “5.5.1 - Pre-installation warnings after prolonged storage”.</b> </div>
Temperature	Not above 25°C
Humidity	Not above 70%
Radiation	Away from radiation sources according to UNI ISO 2230:2009

Tab. 5.52

### 5.5.1 - PRE-INSTALLATION WARNINGS AFTER PROLONGED STORAGE

For installations that have been stored for longer than 3 years, the condition of all rubber parts must be checked and, if found to be damaged, they must be replaced in order to ensure the correct functioning of the equipment.

For the replacement of the rubber parts of the equipment, please refer to chapter “9 - Maintenance and functional checks”.

<div style="border: 1px solid black; padding: 5px;">  <b>NOTICE!</b>  <b>PIETRO FIORENTINI S.p.A. recommends checking the condition of rubber parts in case of downtime or storage longer than 3 years.</b> </div>
--

PAGE INTENTIONALLY LEFT BLANK

## 6 - INSTALLATION

### 6.1 - INSTALLATION PRE-REQUISITES

#### 6.1.1 - ENVIRONMENTAL CONDITIONS ALLOWED

##### WARNING!

To safely use the equipment, in full respect of the allowed environmental conditions, follow the data shown on the regulator plate and on any accessories (refer to paragraph “6.1.1 - Environmental conditions allowed”).

The installation site must be suitable for the safe use of the equipment.

The equipment installation area must have lighting that guarantees the operator good visibility during the work phases on the equipment.

##### NOTICE!

The equipment must operate in places that are properly lit by artificial lighting suitable for the protection of the operator (in compliance with UNI EN 12464-1:2011 and UNI EN 12464-2:2014). If maintenance work is to be performed in areas and/or parts that are poorly lit, it is mandatory to:

- use all the light sources of the installation plant;
- be equipped with a lighting system handheld or connected to the power supply network, compliant with Directive 2014/34/EU (ATEX) for use in environments at risk of explosion;
- adhere to the temperature specified on the equipment nameplate.

## 6.1.2 - CHECKS BEFORE INSTALLATION

The device does not require any further upstream safety device for protection against any overpressure with respect to its **PS admissible pressure** when, for the upstream reduction station, the maximum incidental downstream pressure is:

$$\text{MIPd} \leq 1.1 \text{ PS}$$

**MIPd** = Maximum incidental downstream pressure value (for further information, see UNI EN 12186:2014).

### **ATTENTION!**



**If the installation of the equipment requires the application of compression fittings, these must be installed in accordance with the instructions of the Manufacturer of the fittings themselves.**

**The choice of fittings must be compatible with:**

- the use specified for the equipment;
- the plant specifications when required.

Before installation, it must be ensured that:

- the expected dimensions of the installation site are compatible with those of the equipment;
- there are no impediments for the workers in charge of maintenance;
- the upstream and downstream pipes are at the same level and can bear the weight of the equipment;
- the inlet and outlet connections of the pipes are aligned on the flanges;
- the inlet and outlet connections of the equipment are clean and intact;
- the inside of the upstream pipe is clean and free of processing residues such as welding slag, sand, paint residues, water, etc...

Installation	
<b>Operator qualification</b>	Installer
<b>PPE required</b>	<div style="display: flex; align-items: center;">  </div> <div style="background-color: #ff8c00; padding: 5px; margin-top: 5px;">  <b>WARNING!</b> </div> <p><b>The PPE listed in this table is related to the risk associated with the equipment. For the required PPE to protect against risks associated with the workplace, installation or operating conditions, please refer to:</b></p> <ul style="list-style-type: none"> <li>• the regulations in force in the country of installation;</li> <li>• any information provided by the Safety Manager at the installation facility.</li> </ul>
<b>Equipment required</b>	Please refer to the chapter "6.1.1 - Environmental conditions allowed".

Tab. 6.53

## 6.2 - SPECIFIC SAFETY INSTRUCTIONS FOR THE INSTALLATION PHASE

### **WARNING!**

Before proceeding with installation, make sure that the upstream and downstream valves installed on the line are shut off.

### **WARNING!**

Installation may also take place in areas where there is a risk of explosion, which implies that all necessary prevention and protection measures have to be taken.

For these measures, please refer to the regulations in force at the place of installation.

### 6.3 - GENERAL INFORMATION ON CONNECTIONS

The equipment must be installed in-line with an arrow on the body pointing to the gas flow direction. In line installation as well as in square installation, they must be present (see Fig. 6.22 and Fig. 6.23):

Pos.	Description
1	1 <b>slam shut valve</b> upstream of the equipment
2	2 <b>vent valves</b> set up one upstream and one downstream of the equipment.
3	2 <b>pressure gauges</b> set up one upstream and one downstream of the equipment.
4	1 <b>pressure regulator</b> .
5	1 <b>downstream shut-off valve</b> .

Tab. 6.54

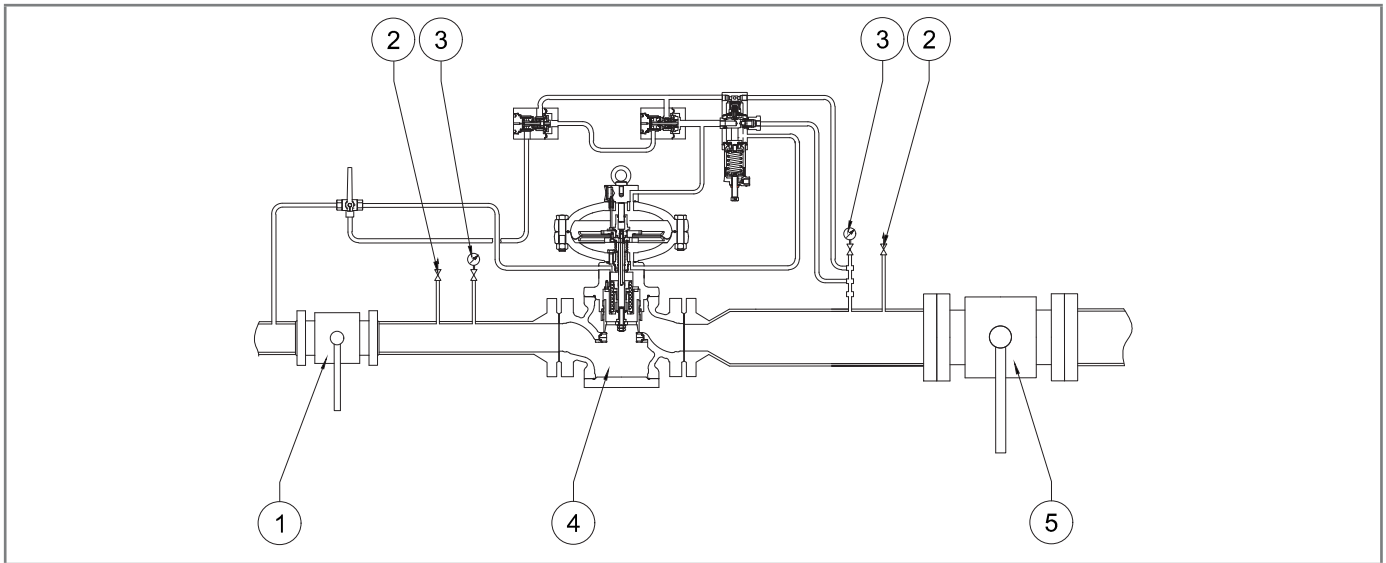

Fig. 6.22. Inline installation

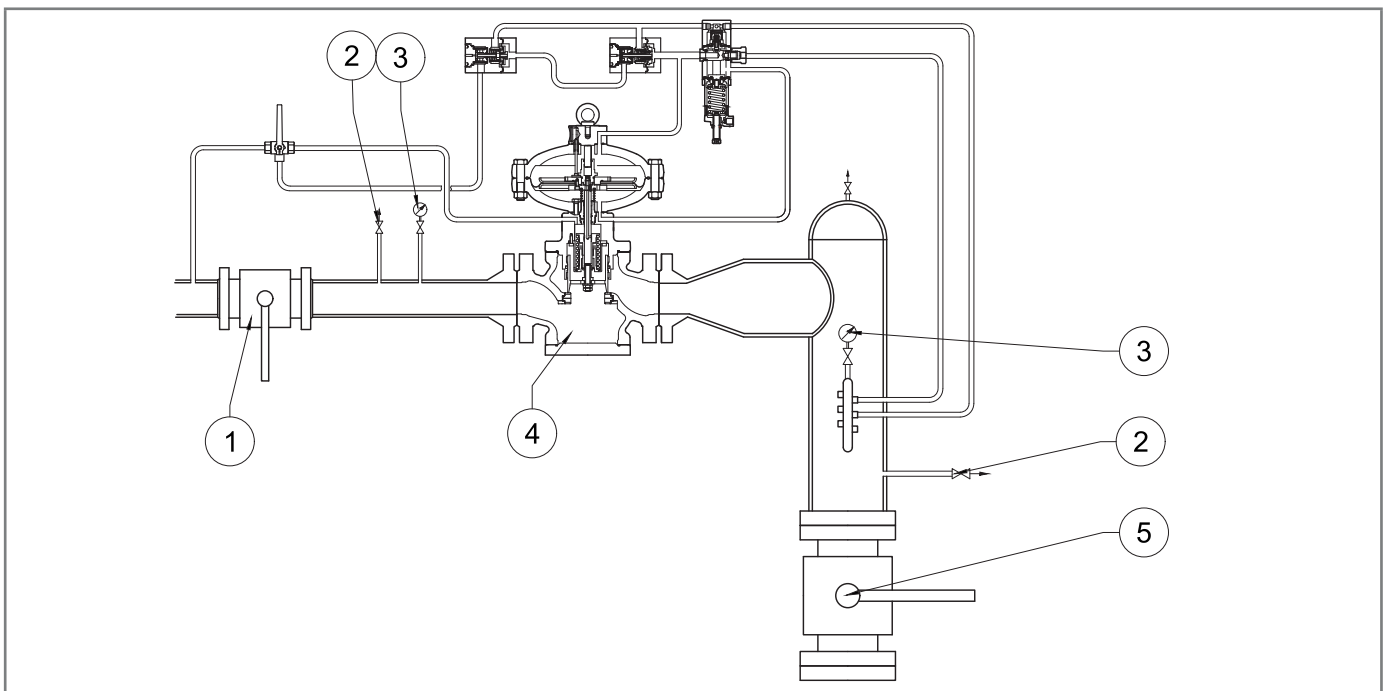

Fig. 6.23. Angle installation

**! NOTICE!**

When used in gas pressure reduction stations, the device must be installed at least according to the requirements of standards UNI EN 12186:2014 or UNI EN 12279:2007.

Equipment vents must be ducted in accordance with UNI EN 12186:2014 or UNI EN 12279:2007 or the standards in force at the place of installation of the equipment.

## 6.4 - REGULATOR INSTALLATION POSITIONS

Fig. 6.24 and Fig. 6.25 illustrate typical regulator arrangements:

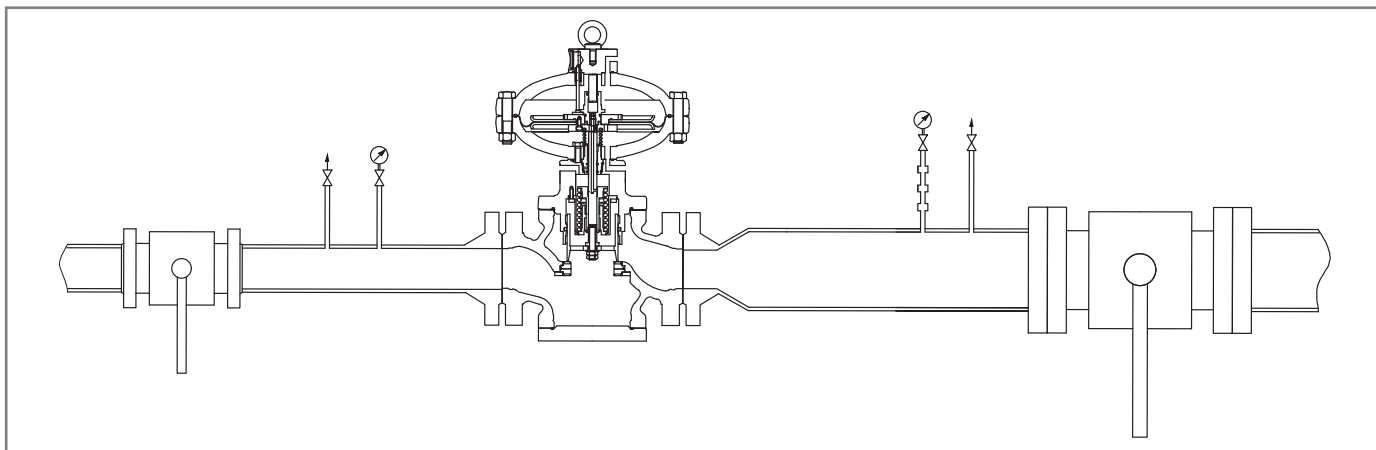

Fig. 6.24. Standard position

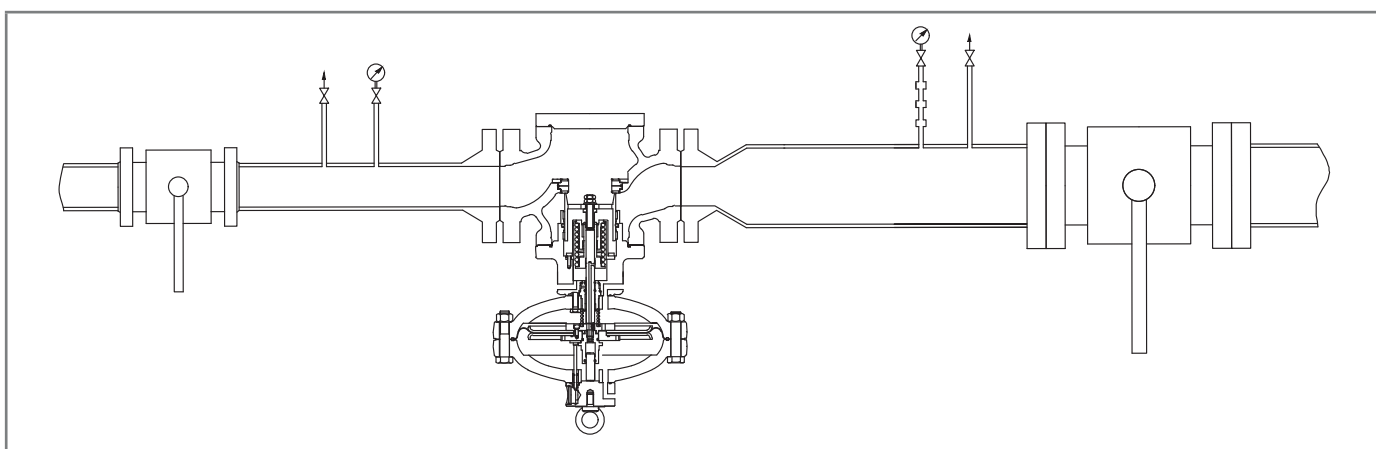

Fig. 6.25. Inverted position

## 6.5 - INSTALLATION PROCEDURE

### 6.5.1 - EQUIPMENT INSTALLATION PROCEDURE

Step	Action
1	Place the equipment in the section of the line designated for it.
2	Place the gaskets between the line flange and the regulator flange.
3	Insert the bolts into the appropriate holes of the connecting flanges.
4	Screw the bolts following the technical rules for tightening flanges.

Tab. 6.55

#### NOTICE!

For installation after maintenance, replace the seals.

### 6.5.2 - CONNECTION OF THE SENSING LINES TO THE DOWNSTREAM PIPING

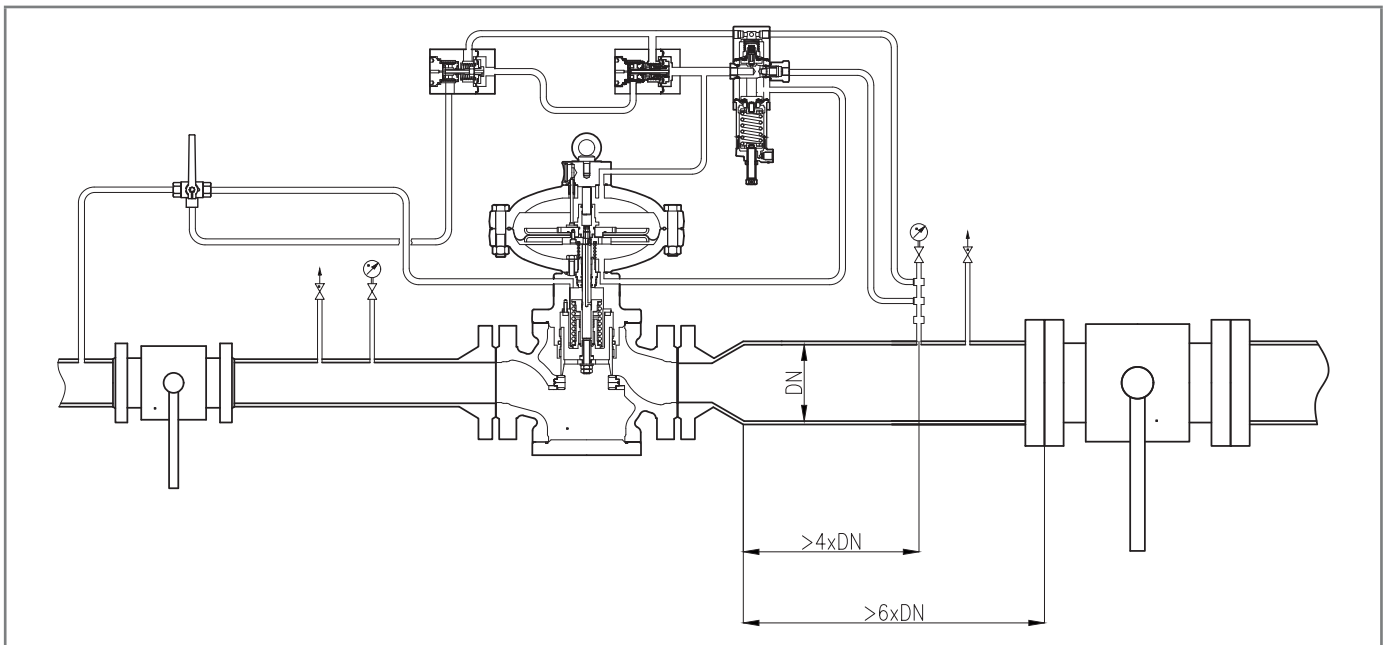

Fig. 6.26. Connection of sensing lines to the downstream piping

For proper adjustment, it is essential that:

- the downstream shut-off valve is placed at a distance of at least 6 times the nominal diameter of the pipe downstream of the regulator;
- the downstream sensing lines are placed on a straight section of pipe (with uniform diameter) having a length equal to at least 4 times the rated diameter of the pipe itself;

#### ATTENTION!

**The pilot drain must not be connected to the multi-socket switch.**

For optimum performance, the velocity of the pressurised fluid at the intake point should not exceed the following values:

$$V_{\max} = 30 \text{ m/s for } P_a > 5 \text{ bar}$$

$$V_{\max} = 25 \text{ m/s for } P_a < 5 \text{ bar}$$

As a limitation of use, the velocity of the pressurised fluid at the intake point does not exceed the following values:

$$V_{\max} = 40 \text{ m/s for } P_a > 5 \text{ bar}$$

To calculate the flow rate, use the following formula:

$$V = 345,92 \times \frac{Q}{DN^2} \times \frac{1 - 0,002 \times Pd}{1 + Pd}$$

**V** = gas velocity in m/sec

**Q** = gas flow rate in Sm<sup>3</sup>/h

**DN** = nominal pipe diameter in mm

**Pd** = regulator outlet pressure in barg

**! NOTICE!**

**All on-site pneumatic connections must have pipes with a minimum internal diameter of 8 mm.**

To prevent the sensing line pipes from collecting impurities and condensation, it is necessary that:

- the pipe connections are always welded on the upper part or at maximum 90 degrees on the axis of the pipe (refer to Fig. 6.27);
- the hole in the piping has no burrs or internal protrusions;
- the slope of the pipe is always 5-10% towards the downstream pipe connection.

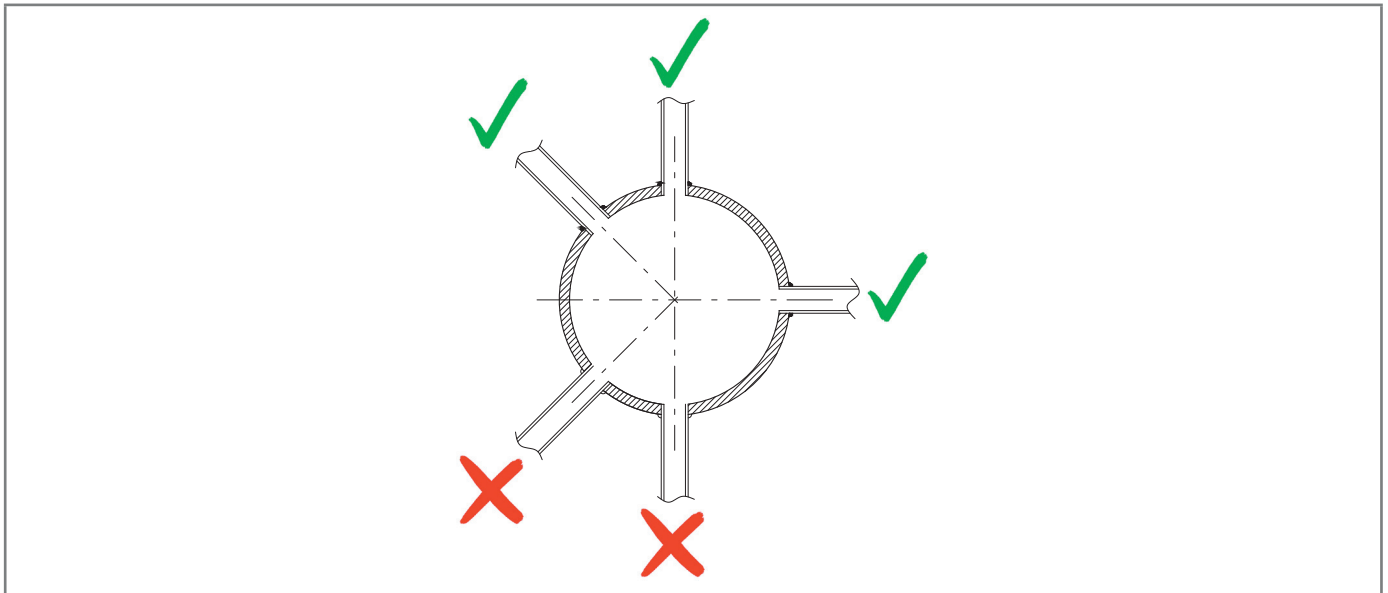

Fig. 6.27. Welded pipe connections

If there is a sensing line, connect the equipment connections as shown below:

- 1 and 2 to the discharge outlet of the control head of the PM/819 monitor, if any;
- 3 and 4 to the pilot sensing lines;
- 5 and 6 to the sensing lines of the block accelerating valve, when present.

**! NOTICE!**

**If there is a multiple sensing line, it is not recommended to place shut-off valves on sensing lines.  
In any case, follow the regulations in force in the place of installation and use of the equipment.**

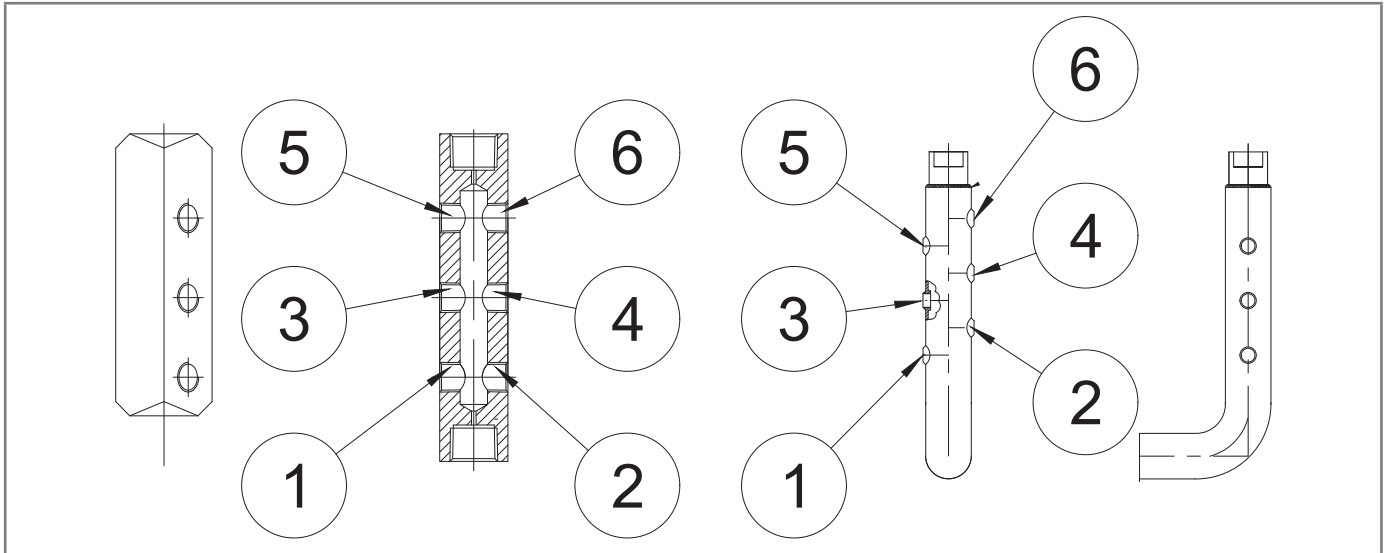

Fig. 6.28. Equipment connections

## 6.6 - POST-INSTALLATION AND PRE-COMMISSIONING CHECKS

When the equipment is operating, make sure that all connections are:

- properly secured/tightened to prevent any leakage during commissioning;
- connected correctly.







## 7 - COMMISSIONING/MAINTENANCE EQUIPMENT





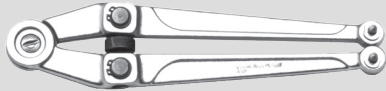

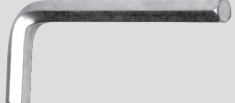

### 7.1 - LIST OF EQUIPMENT

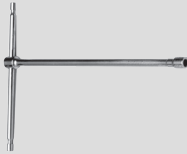
Use of commissioning/maintenance equipment	
<b>Operator qualification</b>	<ul style="list-style-type: none"> <li>• Mechanical maintenance technician;</li> <li>• Electrical maintenance technician;</li> <li>• Installer;</li> <li>• User technician.</li> </ul>
<b>PPE required</b>	<div style="display: flex; align-items: center;">  </div> <div style="background-color: #f4a460; padding: 5px; margin-top: 5px;"> <p><b>⚠ WARNING!</b></p> </div> <p>The PPE listed in this table is related to the risk associated with the equipment. For the required PPE to protect against risks associated with the workplace, installation or operating conditions, please refer to:</p> <ul style="list-style-type: none"> <li>• the regulations in force in the country of installation;</li> <li>• any information provided by the Safety Manager at the installation facility.</li> </ul>

Tab. 7.56

The types of equipment required to commission and service the equipment are described in Tab. 7.57:

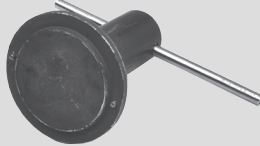
Ref.	Equipment type	Image
<b>A</b>	Combination wrench	
<b>B</b>	Adjustable wrench	
<b>C</b>	Compass wrench	
<b>D</b>	Double ended bi-hex tubular socket wrench	
<b>E</b>	Bent male hex wrench	
<b>F</b>	Male hex T-key	

Ref.	Equipment type	Image
<b>G</b>	T-handle hexagon socket spanner	
<b>H</b>	Phillips screwdriver	
<b>I</b>	Slotted screwdriver	
<b>L</b>	O-ring extraction tool	
<b>M</b>	Circlip pliers	
<b>N</b>	Fiorentini special key	
<b>O</b>	Fiorentini special key	
<b>P</b>	Fiorentini special tool	

Tab. 7.57

## 7.2 - EQUIPMENT NEEDED FOR THE DIFFERENT CONFIGURATIONS

Each table is distinguished by:

Term	Description
<b>K./Wr.</b>	Key, with reference to the equipment indicated in Tab. 7.57.
<b>Code</b>	Code, referring to the equipment.
<b>DN</b>	Indicates the Nominal Diameter of the reference configuration.
<b>L.</b>	Length, referring to the equipment.
<b>Ref.</b>	Reference to the equipment.
<b>Type</b>	Type (size) or code of the equipment.

Tab. 7.58.

REFLUX 819/FO								
Equipment		Size [inches]   DN [mm]						
Ref.	Type	25   1"	50   2"	80   3"	100   4"	150   6"	200   8"	250   10"
<b>A</b>	K./Wr.	13-15-17- 19-24-30	13-15-17- 19-24-30	13-15-17- 19-24-27- 30	13-15-17- 19-24-27- 30	13-15-17- 19-24-30- 32-41	13-15-17- 19-24-30- 32-41	13-15-17- 19-24-32- 46-50
<b>B</b>	L.	300						
<b>C</b>	Ø	4						
<b>D</b>	K./Wr.	-	-	-	-	27-41	27-41	30-55
<b>E</b>	K./Wr.	3-12	3-12	3-12	3-12	3-12	3-12	3-12
<b>F</b>	K./Wr.	5-6-8	5-6-10	5-6-10	5-6-14	5-6-17	5-6-17	5-6-17
<b>G</b>	K./Wr.	17-20	17-20	17-19-22	17-19-22	22	22	-
<b>L</b>	Code	7999099						

Tab. 7.59

REFLUX 819/FO + DB/819								
Equipment		Size [inches]   DN [mm]						
Ref.	Type	25   1"	50   2"	80   3"	100   4"	150   6"	200   8"	250   10"
<b>A</b>	K./Wr.	13-15-17- 19-22-24- 30	13-15-17- 19-24-27- 30	13-15-17- 19-24-27- 30	13-15-17- 19-24-27- 30	13-15-17- 19-24-30- 32-41	13-15-17- 19-24-30- 32-36-41	13-15-17- 19-24-32- 46-50
<b>B</b>	L.	300						
<b>C</b>	Ø	4						
<b>D</b>	K./Wr.	-	-	-	-	27-41	27-41	30-55
<b>E</b>	K./Wr.	3-12	3-12	3-12	3-12	3-12	3-12	3-12
<b>F</b>	K./Wr.	5-6-8	5-6-10	5-6-10	5-6-14	5-6-17	5-6-17	5-6-17
<b>G</b>	K./Wr.	17-20	17-20	17-19-22	17-19-22	22	22	-
<b>L</b>	Code	7999099						
<b>O</b>	Code	7999031	7999033	7999035	7999036	7999037	7999038	7999041

Tab. 7.60

REFLUX 819/FO + PM/819								
Equipment		Size [inches]   DN [mm]						
Ref.	Type	25   1"	50   2"	80   3"	100   4"	150   6"	200   8"	250   10"
<b>A</b>	K./Wr.	13-15-17- 19-24-30	13-15-17- 19-24-30	13-15-17- 19-24-27- 30	13-15-17- 19-24-27- 30	13-15-17- 19-24-30- 32-41	13-15-17- 19-24-30- 32-41	13-15-17- 19-24-32- 46-50
<b>B</b>	L.	300						
<b>C</b>	Ø	4						
<b>D</b>	K./Wr.	-	-	-	-	27-41	27-41	30-55
<b>E</b>	K./Wr.	3-12	3-12	3-12	3-12	3-12	3-12	3-12
<b>F</b>	K./Wr.	5-6-8	5-6-10	5-6-10	5-6-14	5-6-17	5-6-17	5-6-17
<b>G</b>	K./Wr.	17-20	17-20	17-19-22	17-19-22	22	22	-
<b>L</b>	Code	7999099						

Tab. 7.61

REFLUX 819/FO + SB/82								
Equipment		Size [inches]   DN [mm]						
Ref.	Type	25   1"	50   2"	80   3"	100   4"	150   6"	200   8"	250   10"
<b>A</b>	K./Wr.	8-13-14-15- 17-19-24- 27-30-32	8-13-14-15- 17-19-24- 27-30-32	8-13-14- 15-17-19- 24-30-32	8-13-14- 15-17-19- 24-27-30- 32	8-13-14- 15-17-19- 24-27-30- 32-41	8-13-14- 15-17-19- 24-27-30- 32-41	8-13-14- 15-17-19- 24-27-32- 46-50
<b>B</b>	L.	300						
<b>C</b>	Ø	4						
<b>D</b>	K./Wr.	10-15-24	10-15-24	10-15-24	10-15-24	9-10-15- 24-27-41	9-10-15- 24-27-41	9-10-15- 24-30-55
<b>E</b>	K./Wr.	2-3-4-8-12	2-3-4-10-12	2-3-12	2-3-4-5-12	2-3-4-5-12	2-3-4-5-12	2-3-4-5-12
<b>F</b>	K./Wr.	5-6	5-6	5-6	5-6	5-6	5-6	5-6
<b>G</b>	K./Wr.	17-20	17-20	17-19-22	17-19-22	22	22	-
<b>L</b>	Code	7999099						
<b>M</b>	Ø	19-60						
<b>N</b>	Code	7999019						

Tab. 7.62

REFLUX 819/FO + HB/97						
Equipment						
Ref.	Type	100   4"	150   6"	200   8"	250   10"	300   12"
<b>A</b>	K./Wr.	8-13-14-15-17-19-24-27-30-32	8-13-14-15-17-19-24-27-30-32-41	8-13-14-15-17-19-24-27-30-32-41	8-13-14-15-17-19-24-27-32-46-50	17-19-22-24-32-50-65
<b>B</b>	L.	300				
<b>C</b>	Ø	4				
<b>D</b>	K./Wr.	10-15-24	9-10-15-24-27-41	9-10-15-24-27-41	9-10-15-24-30-55	41-65-17
<b>E</b>	K./Wr.	2-3-4-5-12	2-3-4-5-12	2-3-4-5-12	2-3-4-5-12	3-6
<b>F</b>	K./Wr.	5-6	5-6	5-6	5-6	6
<b>G</b>	K./Wr.	17-19-22	22	22	-	-
<b>L</b>	Code	7999099				
<b>M</b>	Ø	19-60				
<b>N</b>	Code	7999019				
<b>P</b>	Code	7999097				

Tab. 7.63

PAGE INTENTIONALLY LEFT BLANK

## 8 - COMMISSIONING

### 8.1 - GENERAL WARNINGS

#### 8.1.1 - SAFETY REQUIREMENTS FOR COMMISSIONING

##### HAZARD!

During commissioning the risks associated with any discharges to the atmosphere of flammable or noxious gases must be evaluated.

##### HAZARD!

In case of installation on distribution networks for natural gas, consider the risk associated with explosive mixtures (gas/air) being formed inside the piping, if the line is not subjected to inerting.

##### WARNING!

During commissioning, any unauthorised personnel must keep away.  
The 'no entry' area has to be marked with signs and/or boundaries.

##### NOTICE!

Commissioning has to be carried out by authorised and qualified personnel.

The equipment is supplied with the pilot unit already calibrated.

Even if the PM/819 built-in monitor or the SB/82 and HB/97 built-in slam-shut valves are mounted on the equipment, and pressure switches present will be already calibrated.



##### NOTICE!

It is possible that for various reasons (e.g. vibrations during transport) the calibration of the equipment's accessories may vary, although within the values indicated on the identification plates.

Before commissioning the equipment, it is necessary to check that:

- all shut-off valves (inlet, outlet, any bypass) are closed;
- the gas is at a temperature within the limits specified on the data plate.

#### Commissioning

<b>Operator qualification</b>	<ul style="list-style-type: none"> <li>• Installer;</li> <li>• Qualified technician.</li> </ul>
<b>PPE required</b>	 <p> <b>WARNING!</b></p> <p>The PPE listed in this table is related to the risk associated with the equipment. For the required PPE to protect against risks associated with the workplace, installation or operating conditions, please refer to:</p> <ul style="list-style-type: none"> <li>• the regulations in force in the country of installation;</li> <li>• <u>any information provided by the Safety Manager at the installation facility.</u></li> </ul>
<b>Equipment required</b>	Please refer to the chapter "7 - Commissioning/maintenance equipment".

Tab. 8.64

## 8.2 - PRELIMINARY PROCEDURES FOR COMMISSIONING

### HAZARD!

Before commissioning the equipment, it must be ensured that any source of explosion has been eliminated if there is such a danger.

### WARNING!

Before commissioning, you need to make sure that the characteristics of the equipment are suitable for the conditions of use.

### ATTENTION!

To protect the equipment from damage, the following operations must never be carried out:

- pressurisation through a valve located downstream of the equipment;
- depressurise the equipment through a valve located upstream of it.

Commissioning can be carried out using two different procedures:

### Commissioning types

<b>Injection of an inert fluid</b>	Pressurising the equipment by injecting an inert fluid (e.g. nitrogen) to avoid potentially explosive mixtures for services with combustible gases. <div data-bbox="343 929 1476 1019" style="background-color: #f4a460; padding: 5px;"> <p> <b>WARNING!</b>  <b>During pressurisation, always check that the equipment has no leaks.</b></p> </div>
<b>Direct injection</b>	Direct injection of gas into pipes, keeping the gas velocity in the pipes as low as possible (maximum permitted value of 5 m/s).

Tab. 8.65

### 8.3 - PROPER COMMISSIONING CHECK

Completely sprinkle the equipment (or equivalent control system) with a foaming solution in order to check the tightness of the regulator's external surfaces and of the connections made during installation.

### 8.4 - CALIBRATION OF ANY ACCESSORIES

 **NOTICE!**

To properly calibrate the equipment and accessories present, refer to the accuracy class indicated on the nameplates (see "2.8 - Applied rating plates").

### 8.5 - REGULATOR COMMISSIONING PROCEDURE

In the application consisting of multiple pressure adjusting lines, it is advisable to commission one line at a time, starting with the line with the lowest set point.

The set point value is mentioned on the test certificate enclosed with each piece of equipment.

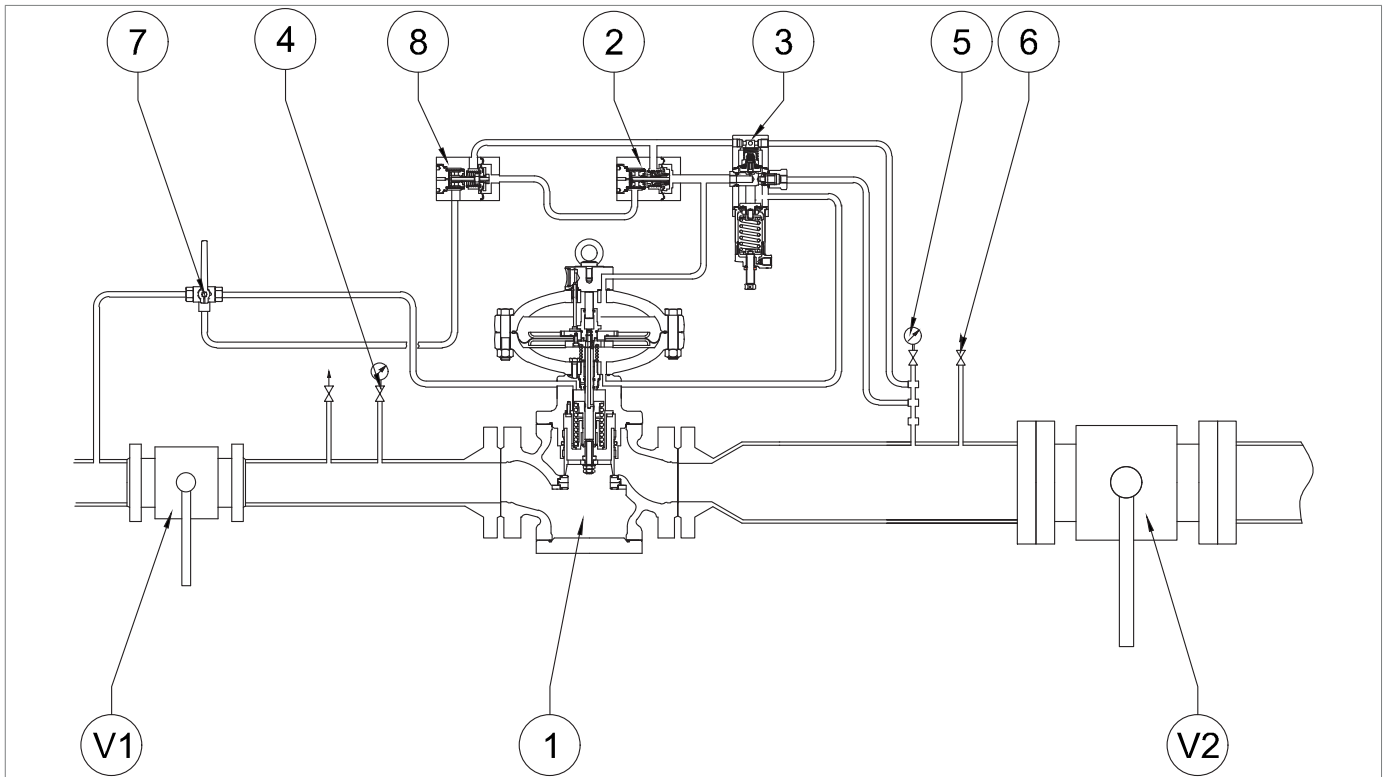

Fig. 8.29. Commissioning the regulator

Step	Action
1	Partially open the air vent valve (6).
2	Completely unscrew the fixing nut and adjusting screw (Fig. 8.37, ref.10) of the pilot (3) to relieve the spring.
3	Set the 3-way valve (7) to the by-pass position.
4	<p>Check that the regulator is fully shut off (0%) by checking the position of the stroke indicator rod (Fig. 4.1).</p> <p><b>! NOTICE!</b></p> <p><b>Check the pressure referring to the pressure gauge (5) located upstream.</b></p>
5	<p>Open the upstream shut-off valve (V1) very slowly.</p> <p><b>! NOTICE!</b></p> <p><b>Check the pressure by referring to the pressure gauge (4) located upstream.</b></p>
6	Set the 3-way valve (7) to the operating position.
7	<p>Turn the pilot adjusting screw (3) clockwise to load the calibration spring until the pre-set downstream pressure value has been reached.</p> <p><b>! NOTICE!</b></p> <p><b>Check the pressure referring to the pressure gauge (5) located upstream.</b></p>
8	Close the bleed cock (6).
9	<p>Check that the downstream pressure, after an increase phase, does not exceed the shut-off pressure value (refer to the SG value on the nameplate, see par. on page 108).</p> <p><b>! NOTICE!</b></p> <ul style="list-style-type: none"> <li>• <b>If the downstream pressure exceeds the closing pressure value, refer to chapter “10 - Troubleshooting” to clear the causes of the malfunctions.</b></li> <li>• <b>Check the pressure referring to the pressure gauge (5) located upstream.</b></li> </ul>
10	<p>Check the tightness of all the fittings between the shut-off valves (V1, V2).</p> <p><b>! NOTICE!</b></p> <p><b>Check for sealing with a foaming substance.</b></p>
11	<p>Open downstream shut-off valve (V2) very slowly until the pipeline fills completely.</p> <p><b>! NOTICE!</b></p> <p><b>If at the beginning of this operation, the pressure in the downstream pipeline is much lower than the calibration pressure, split the opening of this valve so as not to exceed the maximum flow rate of the system.</b></p>
12	Tighten the adjusting screw and fixing nut (Fig. 8.37, ref.10) of the pilot (3).

Tab. 8.66.

## 8.6 - COMMISSIONING PROCEDURE FOR THE REFLUX 819/FO REGULATOR WITH BUILT-IN MONITOR PM/819

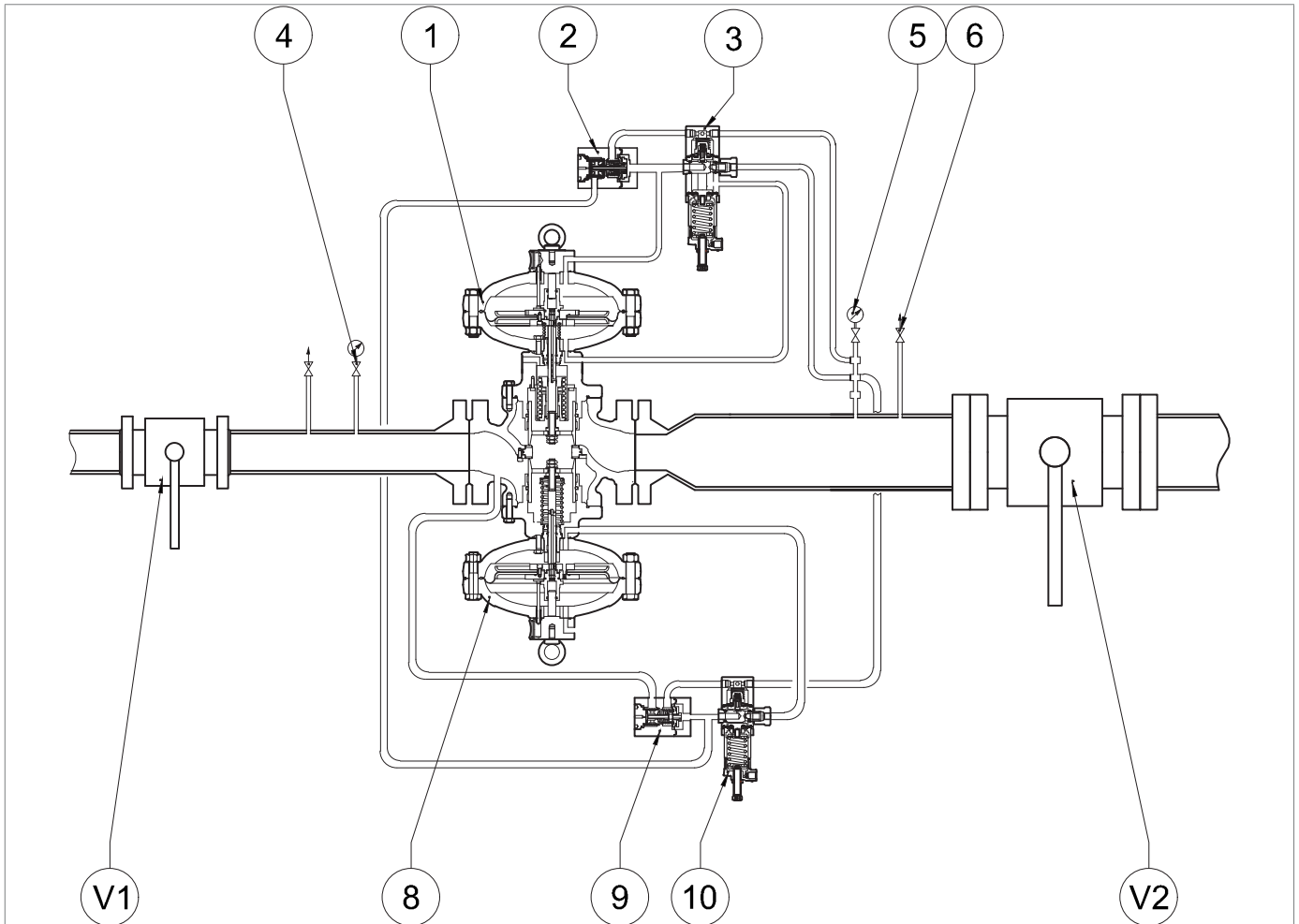

Fig. 8.30. Procedure for commissioning the regulator with PM/819 built-in monitor

Step	Action
1	Partially open the bleed cock (6).
2	Completely unscrew the fixing nut and adjusting screw (Fig. 8.37, ref 10)) of the pilots (3, 10) to relieve the springs.
3	Open the upstream shut-off valve (V1) very slowly. <b>NOTICE!</b> <b>Check the pressure by referring to the pressure gauge (4) located upstream.</b>
4	Completely compress the pilot spring (3) by turning the adjusting screw (Fig. 8.37, ref.10) clockwise.
5	Check that the PM/819 monitor (8) is in fully shut-off position (0%) and the regulator (1) is in fully open position (100%) by checking the position of the stroke indicator rods (Fig. 4.5).
6	Turn the adjustment screw (Fig. 8.37, ref.10) on the monitor pilot (10) clockwise to increase the downstream pressure value to the selected monitor operating value. <b>NOTICE!</b> <b>Check the pressure referring to the pressure gauge (5) located upstream.</b>

Step	Action
7	Turn the adjusting screw (,Fig. 8.37 ref.10) on the pilot (3) anti-clockwise to relieve the calibration spring until the pre-set downstream pressure value has been reached.
8	<p>Make sure that the PM/819 monitor (8) is fully open (100%) by checking the position of the stroke indicator rod (Fig. 4.5).</p> <div style="border: 1px solid black; padding: 5px;"> <p><b>! NOTICE!</b></p> <p><b>Check the pressure referring to the pressure gauge (5) located upstream.</b></p> </div>
9	Slowly close the bleed cock (6).
10	<p>Check that the downstream pressure, after an increase phase, does not exceed the monitor shut-off pressure value (refer to the SG value on the nameplate, see par. 2.8).</p> <div style="border: 1px solid black; padding: 5px;"> <p><b>! NOTICE!</b></p> <ul style="list-style-type: none"> <li>• <b>If the downstream pressure exceeds the closing pressure value, refer to chapter “10 - Troubleshooting” to clear the causes of the malfunctions;</b></li> <li>• <b>Check the pressure referring to the pressure gauge (5) located upstream.</b></li> </ul> </div>
11	<p>Check all joints between the shut-off valves (V1, V2) for sealing.</p> <div style="border: 1px solid black; padding: 5px;"> <p><b>! NOTICE!</b></p> <p><b>Check for sealing with a foaming substance.</b></p> </div>
12	<p>Open downstream shut-off valve (V2) very slowly until the pipeline fills completely.</p> <div style="border: 1px solid black; padding: 5px;"> <p><b>! NOTICE!</b></p> <ul style="list-style-type: none"> <li>• <b>If at the beginning of this operation, the pressure in the downstream pipeline is much lower than the calibration pressure, split the opening of this valve so as not to exceed the maximum flow rate of the system.</b></li> <li>• <b>Check the pressure referring to the pressure gauge (5) located upstream.</b></li> </ul> </div>
13	Secure the adjusting screws with the fixing nuts (Fig. 8.37, ref. 10) of the pilots (3, 10).

Tab. 8.67.

## 8.7 - COMMISSIONING PROCEDURE FOR THE REFLUX 819/FO REGULATOR WITH BUILT-IN PM/819 MONITOR AND M/A THROTTLE

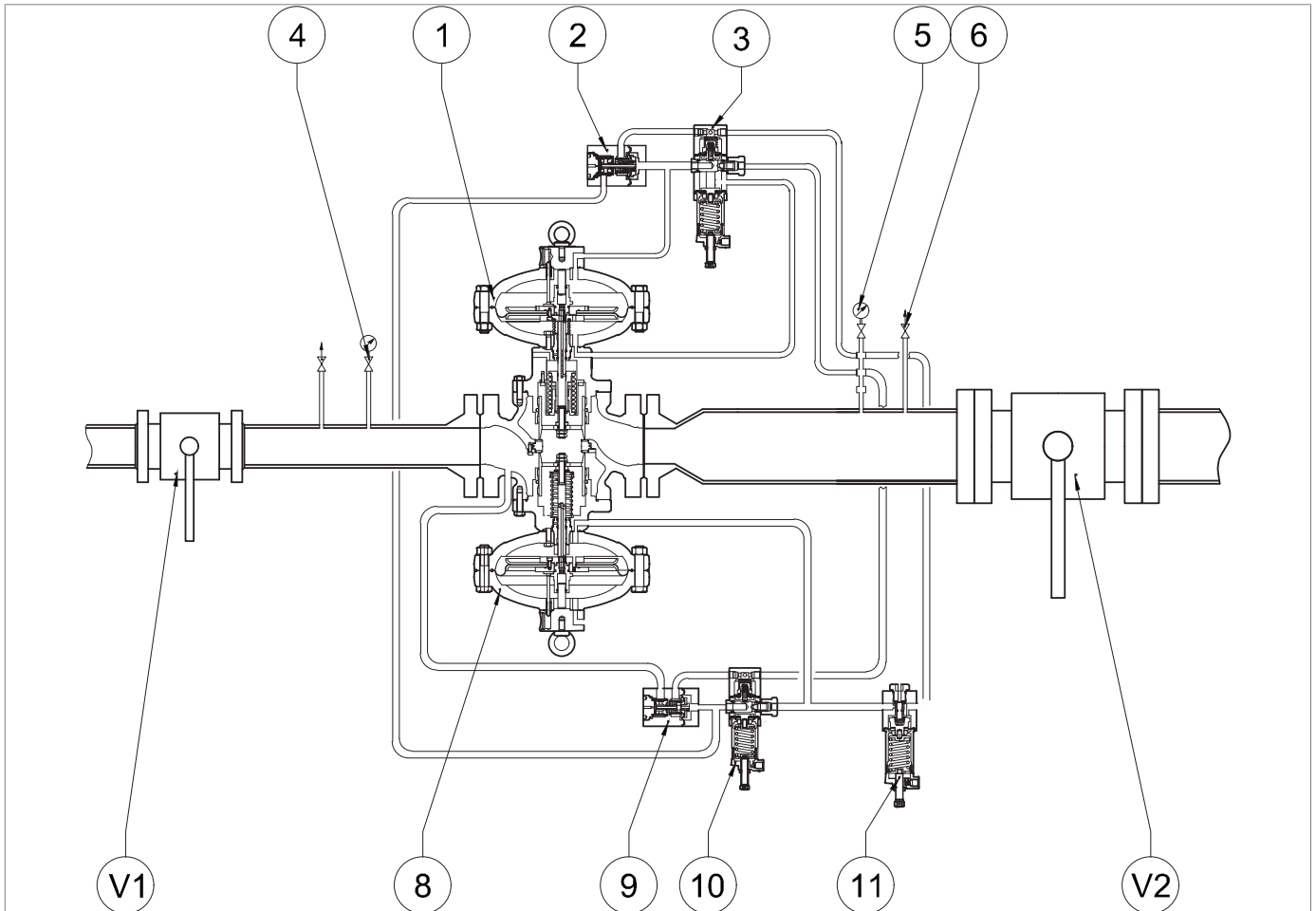

Fig. 8.31. Commissioning of the regulator with built-in PM/819 monitor and M/A accelerating valve

Step	Action
1	Partially open the bleed cock (6).
2	Completely unscrew the fixing nut (Fig. 8.37, ref. 10) and the pilot adjusting screw (3, 10).
3	Fully compress the M/A accelerating valve spring (11) by turning the adjusting screw clockwise.
4	Open the upstream shut-off valve (V1) very slowly. <div style="border: 1px solid black; padding: 5px; margin-top: 5px;"> <p><b>! NOTICE!</b> Check the pressure by referring to the pressure gauge (4) located upstream.</p> </div>
5	Completely compress the pilot spring (3) by turning the adjusting screw (Fig. 8.37, ref.10) clockwise.
6	Check that the PM/819 monitor (8) is in fully shut-off position (0%) and the regulator (1) is in fully open position (100%) by checking the position of the stroke indicator rods (fig. 4.5).
7	Slowly increase the downstream pressure by turning the adjusting screw (Fig. 8.37, ref.10) of the monitor pilot (10) clockwise until the setpoint pressure of the M/A throttle valve (11) is reached. <div style="border: 1px solid black; padding: 5px; margin-top: 5px;"> <p><b>! NOTICE!</b> Check the pressure referring to the pressure gauge (5) located upstream.</p> </div>

Step	Action
8	<p>Turn the adjusting screw of the M/A accelerating valve (11) anti-clockwise to decrease the calibration of the cut-in pressure value until gas is released from the gas outlet.</p> <div style="border: 1px solid black; padding: 5px;"> <p><b>! NOTICE!</b></p> <p><b>Check the gas outlet with a foaming substance.</b></p> </div>
9	<p>Turn the adjusting screw (Fig. 8.37 ref.10) on the monitor pilot (10) anti-clockwise to decrease the downstream pressure value to the selected monitor operating value.</p> <div style="border: 1px solid black; padding: 5px;"> <p><b>! NOTICE!</b></p> <ul style="list-style-type: none"> <li>• <b>Ensuring that the M/A accelerating valve (11) has interrupted the gas discharge;</b></li> <li>• <b>Check the pressure referring to the pressure gauge (5) located upstream.</b></li> </ul> </div>
10	<p>Turn the adjusting screw (Fig. 8.37 ref.10) on the pilot (3) anti-clockwise to relieve the calibration spring until the pre-set downstream pressure value has been reached.</p> <div style="border: 1px solid black; padding: 5px;"> <p><b>! NOTICE!</b></p> <p><b>Check the pressure referring to the pressure gauge (5) located upstream.</b></p> </div>
11	<p>Make sure that the PM/819 monitor (8) is fully open (100%) by checking the position of the stroke indicator rod (Fig. 4.5).</p>
12	<p>Slowly close the bleed cock (6).</p>
13	<p>Check that the downstream pressure, after an increase phase, does not exceed the monitor shut-off pressure value (refer to the SG value on the nameplate, see par. 2.8).</p> <div style="border: 1px solid black; padding: 5px;"> <p><b>! NOTICE!</b></p> <ul style="list-style-type: none"> <li>• <b>If the downstream pressure exceeds the closing pressure value, refer to chapter “10 - Troubleshooting” to clear the causes of the malfunctions.</b></li> <li>• <b>Check the pressure referring to the pressure gauge (5) located upstream.</b></li> </ul> </div>
14	<p>Check all joints between the shut-off valves (V1, V2) for sealing.</p> <div style="border: 1px solid black; padding: 5px;"> <p><b>! NOTICE!</b></p> <p><b>Check for sealing with a foaming substance.</b></p> </div>
15	<p>Open the downstream shut-off valve (V2) very slowly until the pipeline fills completely.</p> <div style="border: 1px solid black; padding: 5px;"> <p><b>! NOTICE!</b></p> <ul style="list-style-type: none"> <li>• <b>If at the beginning of this operation, the pressure in the downstream pipeline is much lower than the calibration pressure, split the opening of this valve so as not to exceed the maximum flow rate of the system.</b></li> <li>• <b>Check the pressure referring to the pressure gauge (5) located upstream.</b></li> </ul> </div>
16	<p>Tighten the adjusting screws (Fig. 8.37, ref.10) and fixing nuts of the pilots (3, 10) and the M/A accelerating valve (11).</p>

Tab. 8.68.

**8.8 - COMMISSIONING PROCEDURE FOR THE REFLUX 819/FO REGULATOR WITH BUILT-IN SLAM-SHUT VALVE SB/82**

**8.8.1 - CHECKING THE SB/82 SLAM-SHUT VALVE FOR PROPER SEALING WHEN CLOSING**

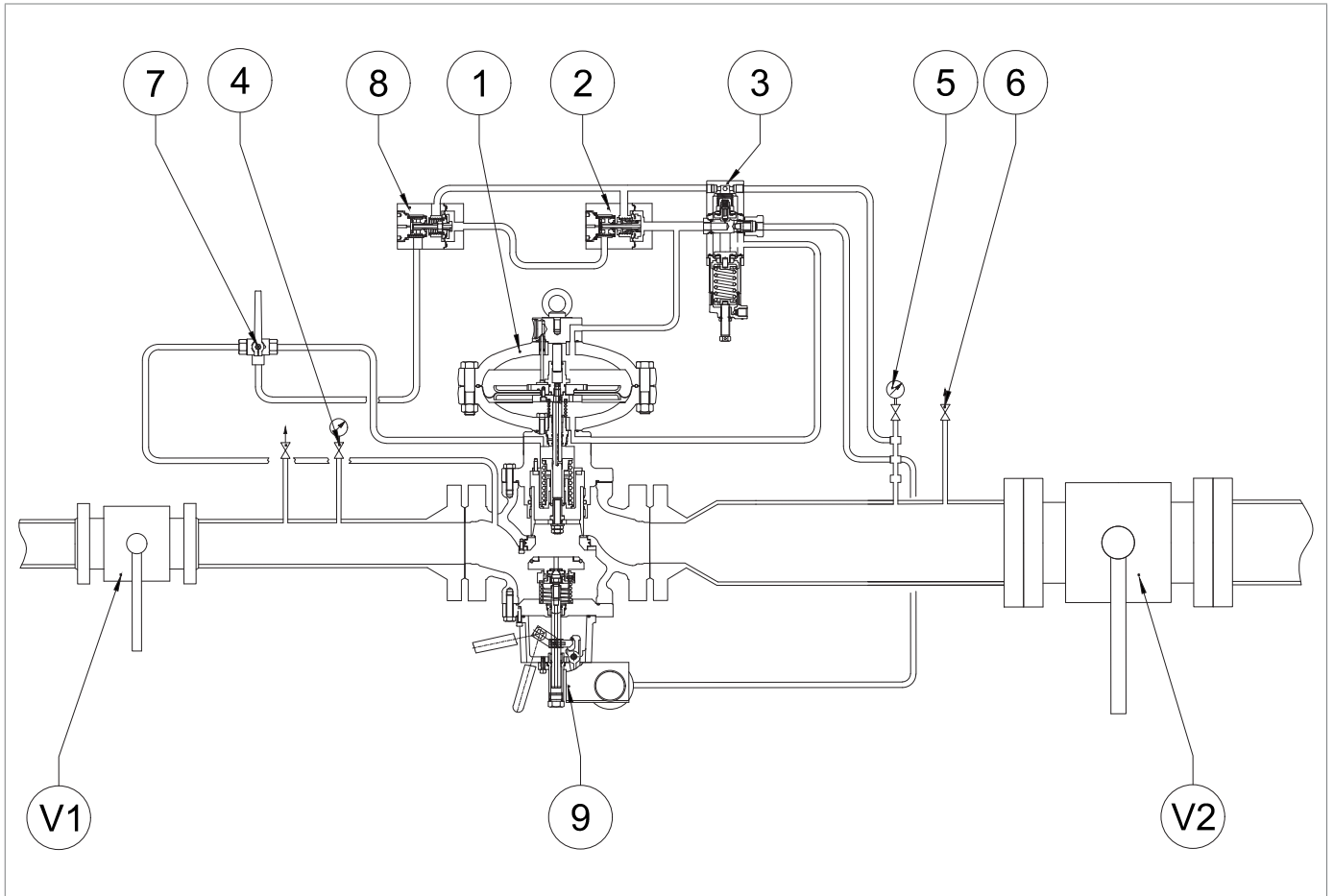

Fig. 8.32. Sealing of the SB/82 slam-shut valve when closing

Step	Action
1	Check that the slam-shut valve (3) is in the closed position.
2	Open the drain cock (6) and drain the downstream section completely.
3	Open the upstream valve (V1) very slowly.
4	<p>Check the tightness of the slam-shut valve (3) through the pilot unit's power connection (2) located under the main regulator's control head (1), disconnecting the connection from the regulator.</p> <div style="border: 1px solid blue; padding: 5px;"> <p><b>! NOTICE!</b></p> <ul style="list-style-type: none"> <li>• <b>Check the seal with a foaming substance;</b></li> <li>• <b>In case of leaks an action, please refer to the chapter “10 - Troubleshooting” to clear the causes of malfunctions.</b></li> </ul> </div>
5	<p>Reconnect the power connection of the drive unit (2) to the main regulator (1).</p> <div style="border: 1px solid blue; padding: 5px;"> <p><b>! NOTICE!</b></p> <p><b>Check whether to replace the fitting by referring to the fitting manufacturers instructions.</b></p> </div>

Tab. 8.69.

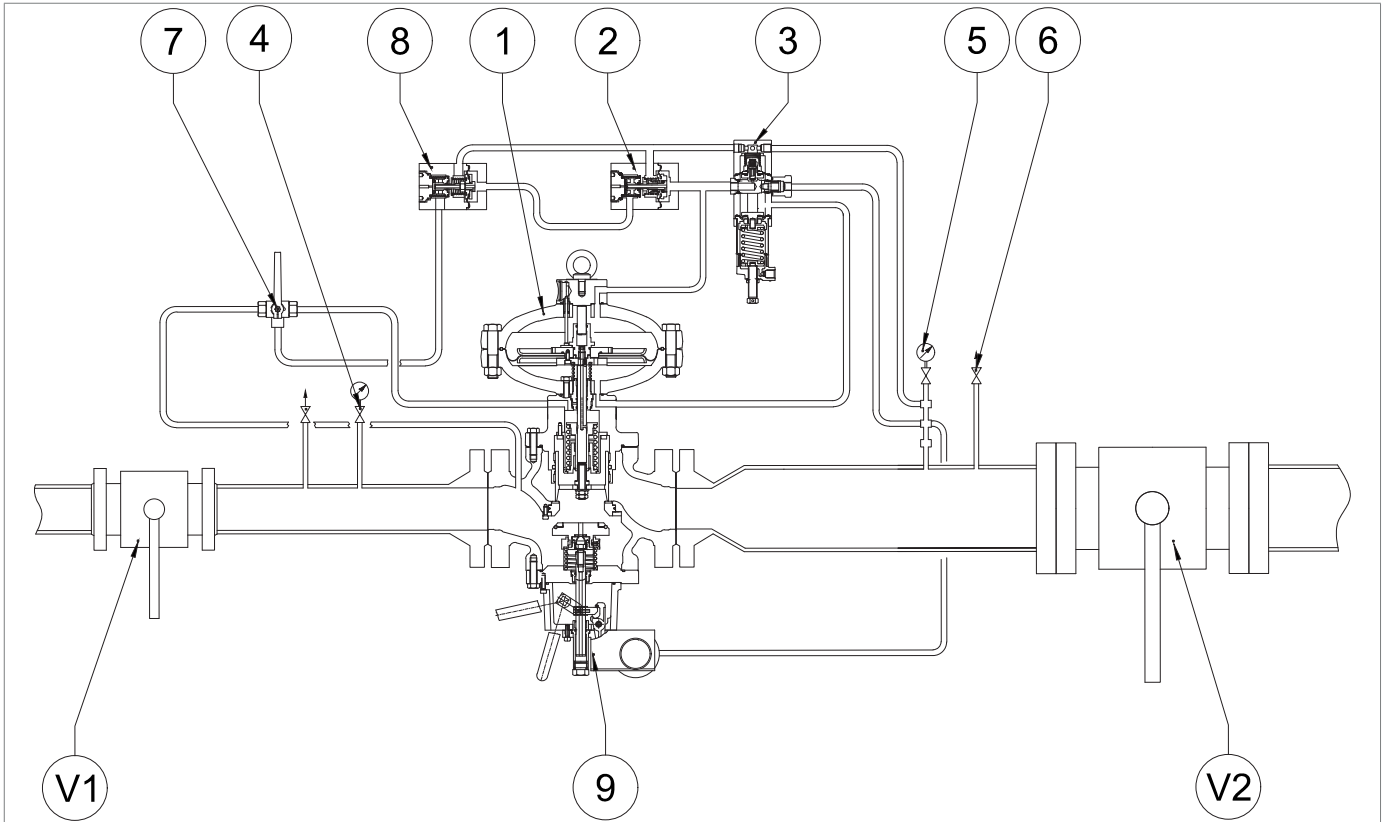

Fig. 8.32. Sealing of the SB/82 slam-shut valve when closing

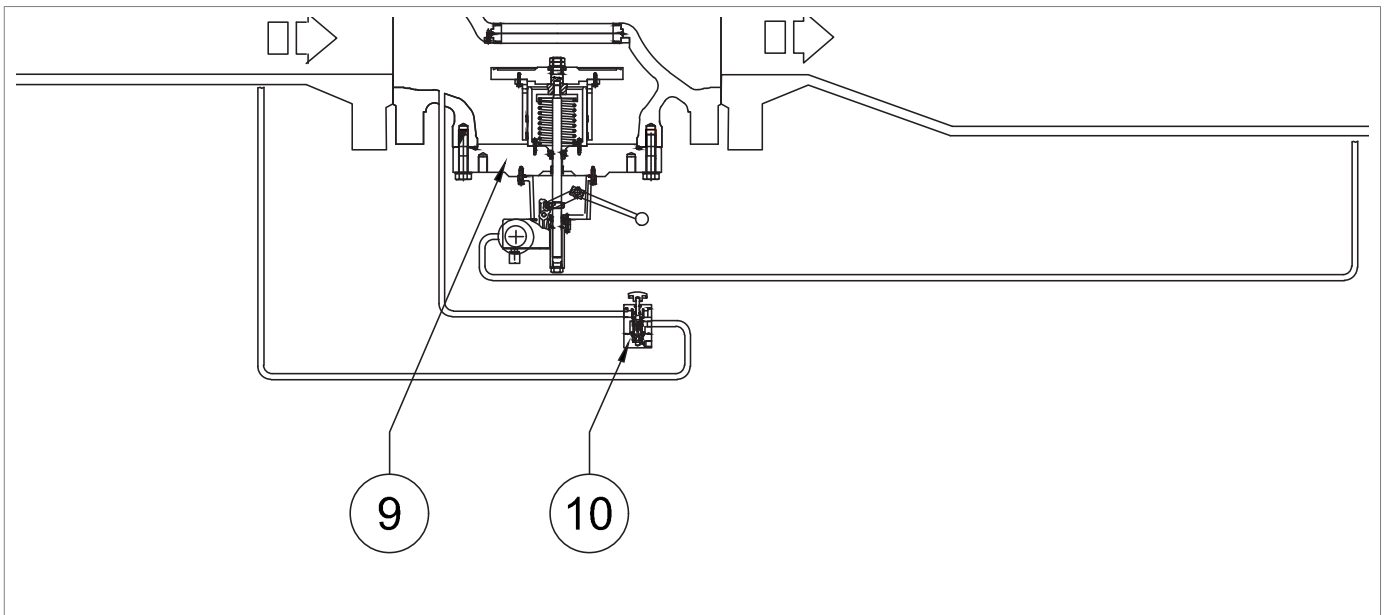





Fig. 8.33. HP2/2 bypass detail for incorporated SB/82 10" slam-shut valve

## 8.8.2 - COMMISSIONING OF THE REGULATOR REFLUX 819/FO WITH SLAM-SHUT VALVE SB/82

For the following procedure, please refer to Fig. 8.32 at “8.8.1 - Checking the SB/82 slam-shut valve for proper sealing when closing”:

Step	Action
1	Make sure that the bleed cock (6) is partially open.
2	<p>Check that the slam-shut valve (9) is in the closed position.</p> <div style="border: 1px solid black; padding: 5px;"> <p> <b>NOTICE!</b>  <b>If the slam-shut valve (9) is in the open position, close it using the manual button (Fig. 8.34, ref.10).</b></p> </div>
3	Set the 3-way valve (7) to the by-pass position.
4	<p>Check that the regulator is fully shut off (0%) by checking the position of the stroke indicator rod (Fig. 4.1).</p> <div style="border: 1px solid black; padding: 5px;"> <p> <b>NOTICE!</b>  <b>Check the pressure referring to the pressure gauge (5) located upstream.</b></p> </div>
5	Partially open the upstream shut-off valve (V1), checking the pressure indicated by the upstream pressure gauge (4).
6	Set the 3-way valve (7) to the operating position.
7	<p>Perform the internal tightness check of the slam-shut valve (9), referring to chapter 8.8.1</p> <div style="border: 1px solid black; padding: 5px;"> <p> <b>NOTICE!</b>  <b>In case of leaks, refer to chapter 10 “Troubleshooting” to clear the causes of the malfunctions.</b></p> </div>
8	<p><b>a- VALID FROM 1" ÷ 8"</b>            Slowly pressurize the regulation line by acting on the reset lever (16) of the slam shut valve (9) (refer to the “Operation” section of par. 4.5.3.1), checking that the downstream pressure (Pd) indicated on the downstream pressure gauge (5) does not exceed the required calibration value by over 50%.</p> <p><b>b- APPLICABLE TO 10" ONLY</b>            Slowly pressurize the regulation line by pressing the HP2/2 by-pass button (10) of the slam shut valve (9) (refer to the “Operation” section of par. 4.5.3.1), checking that the downstream pressure (Pd) indicated on the downstream pressure gauge (5) does not exceed the required calibration value by over 50%.</p>
9	<p>When the regulator is put into service, the pressure on the downstream pressure gauge (5) will be equal to the calibration value of the main regulator.</p> <div style="border: 1px solid black; padding: 5px;"> <p> <b>NOTICE!</b>  <b>In the first line pressurisation phase, the pressure on the downstream pressure gauge (5) could exceed the required calibration value, depending on the response time of the regulator.</b></p> </div>
10	Open the upstream shut-off valve (V1) completely.
11	Check calibrations of the pressure switch of the slam-shut valve (9) by referring to paragraph 8.8.3.

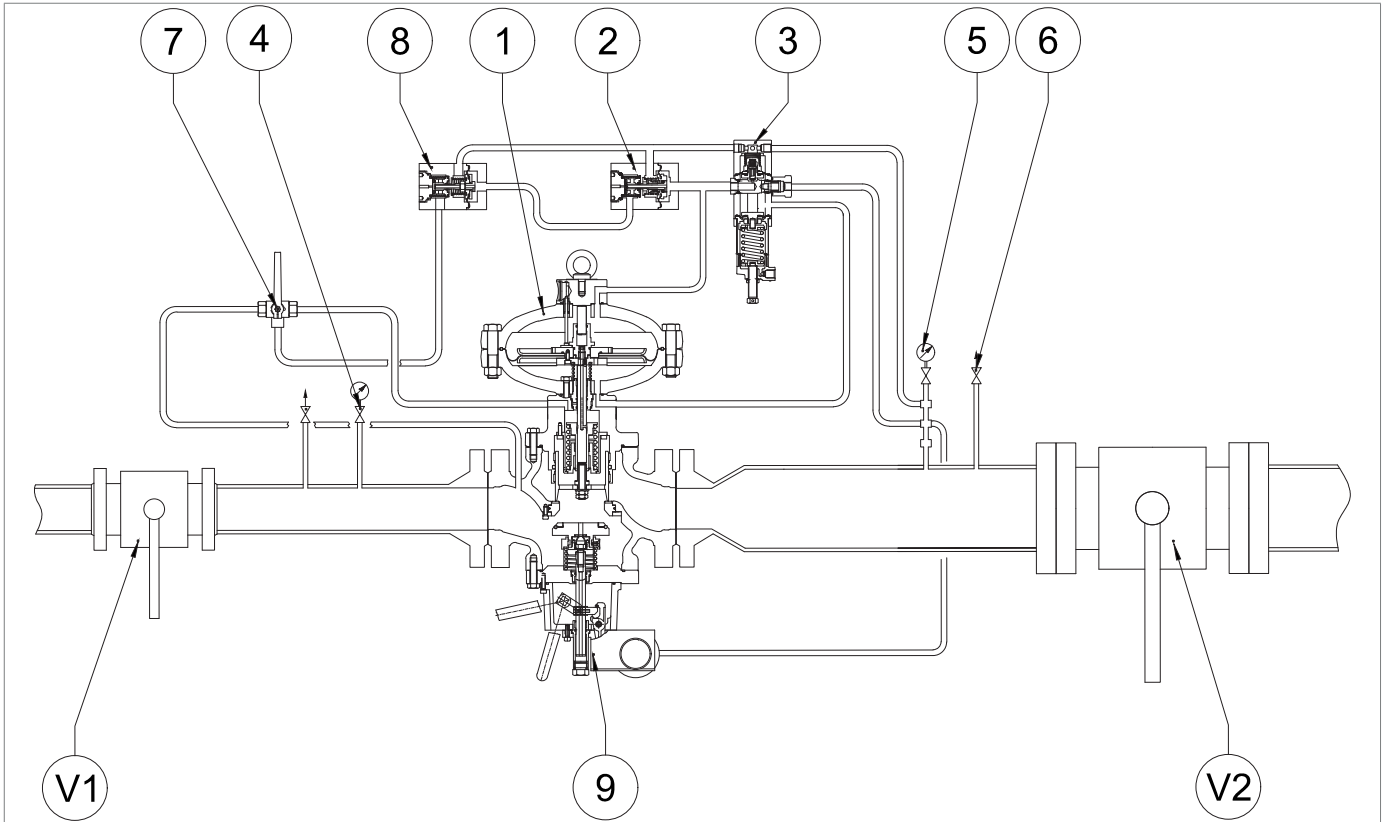

Fig. 8.32. Sealing of the SB/82 slam-shut valve when closing

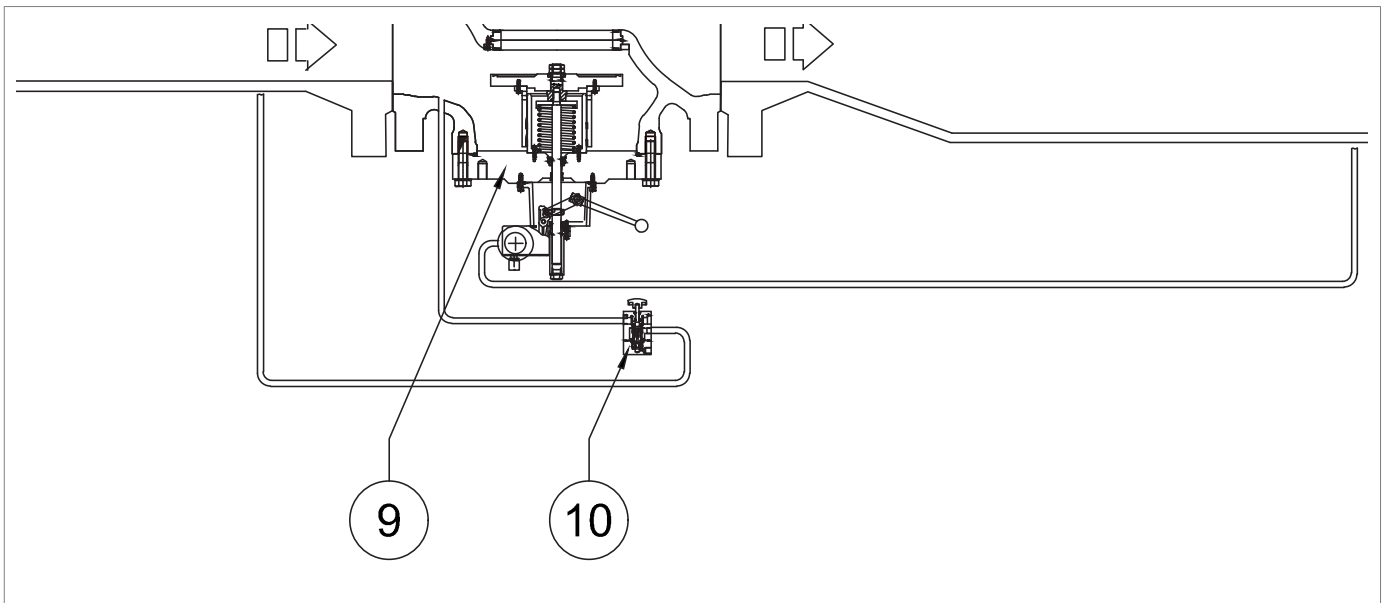

Fig. 8.33. HP2/2 bypass detail for incorporated SBC 82 10" slam-shut valve

Step	Action
12	<p><b>a - FOR INITIAL COMMISSIONING OF THE REGULATION LINE</b></p> <p>If the pressure downstream (Pd) is not at the required calibration value, proceed as follows:</p> <ul style="list-style-type: none"> <li>value of the downstream pressure (Pd) is lower than the required calibration value: load the pilot calibration spring (3) by turning the adjustment screw Fig. 8.37(, ref.10) clockwise</li> <li>value of the downstream pressure (Pd) is higher than the required calibration value: unload the pilot calibration spring (3) by turning the adjustment screw (Fig. 8.37, ref.10) clockwise</li> </ul>
	<p><b>b - AFTER MAINTENANCE OF THE REGULATION LINE</b></p> <ul style="list-style-type: none"> <li>load the pilot setting spring (3) by turning the adjustment screw, (Fig. 8.37, ref.10) clockwise to increase the regulator pressure value (1)</li> </ul>
13	Check the downstream pressure (Pd) referring to the downstream pressure gauge (5).
14	Close the bleed cock (6).
15	<p>Check that the downstream pressure (Pd), after an increment phase, does not exceed the closing pressure value (refer to the SG value displayed on the plate, see par. 2.8).</p>
	<p><b>! NOTICE!</b></p> <p><b>If the pressure in the pipe section between the regulator and the downstream shut-off valve (V2) exceeds the closing pressure value, consult chapter “10 - Troubleshooting” to clear the causes of the malfunctions.</b></p>
16	<p>Check the tightness of all the fittings between the shut-off valves (V1, V2).</p>
	<p><b>! NOTICE!</b></p> <p><b>Check for sealing with a foaming substance.</b></p>
17	If external leaks are found, eliminate the leak points and repeat the procedure from step 7.
18	<p>Open downstream shut-off valve (V2) very slowly until the pipeline fills completely.</p>
	<p><b>! NOTICE!</b></p> <p><b>If the pressure of the downstream pipeline is lower than the calibration pressure, partially open the downstream shut-off valve (V2) so as to not to exceed the maximum flow rate value of the installation.</b></p>

Tab. 8.70.

### 8.8.3 - CALIBRATION PROCEDURE FOR PRESSURE SWITCHES MODELS 102M/102MH ÷ 105M/105MH

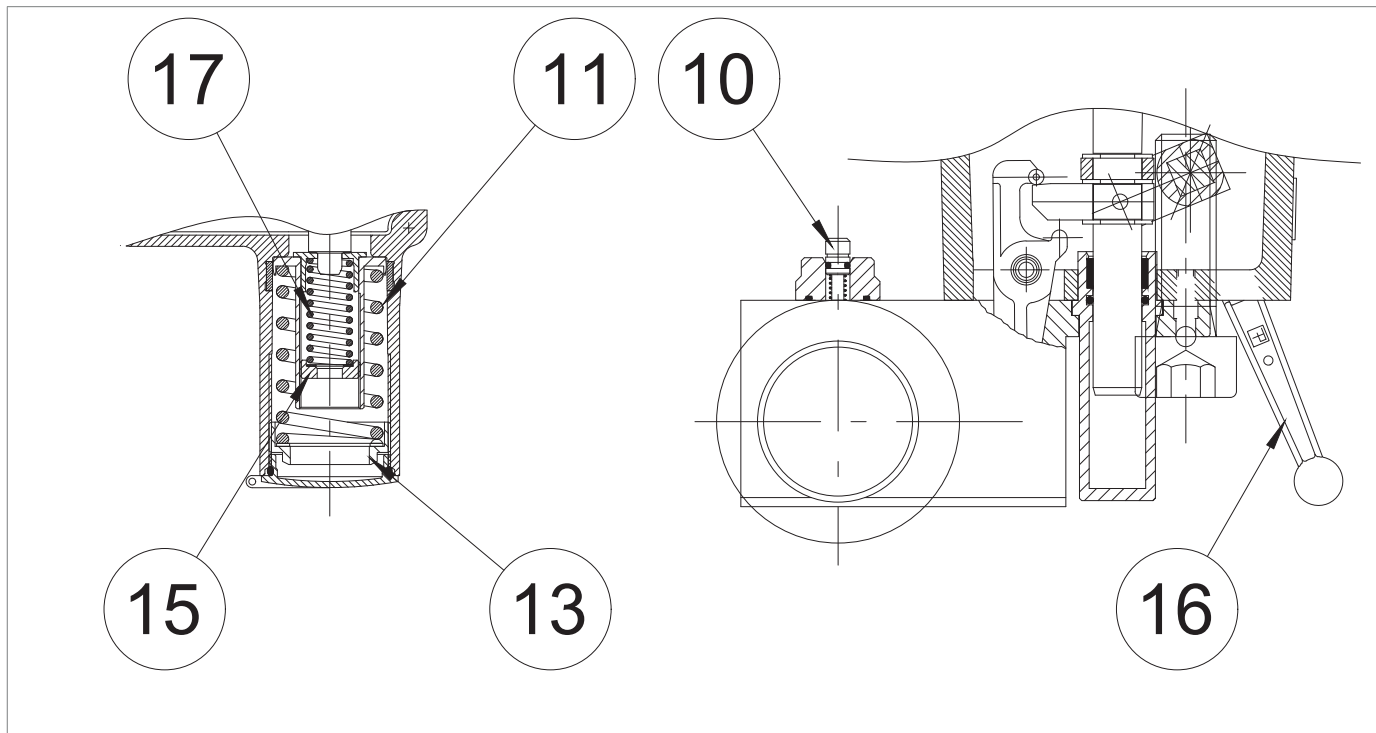



Fig. 8.34. Calibration of pressure switches models 102M/102MH ÷ 105M/105MH

#### SPRING SETTING FOR MAXIMUM PRESSURE TRIPPING

Step	Action
1	<p>Increase the downstream pressure up to the intervention value of the slam shut valve, acting on the adjustment screw (10) of the pilot (Fig. 8.29, ref. 3) of the main regulator (Fig. 8.29, ref. 1), to verify correct calibration.</p> <p><b>! NOTICE!</b></p> <p><b>Check the pressure referring to the pressure gauge (Fig. 8.29, ref.5) downstream of the main regulator.</b></p> <p><b>If the slam-shut valve:</b></p> <ul style="list-style-type: none"> <li>• <b>trips before the expected pressure value: screw in (clockwise) the adjustment ring nut (13) so as to further compress the spring (11);</b></li> <li>• <b>does not trip at the expected pressure value: unscrew (anti-clockwise) the adjustment ring nut (13) so as to relieve the spring (11).</b></li> </ul>
2	By opening the drain cock (Fig. 8.29, ref. 6), decrease the pressure in the downstream section to the calibration value of the main regulator.
3	Close the bleed cock (Fig. 8.29, ref.6).
4	<p>Reset the slam-shut valve by acting on the reset lever (16).</p> <p><b>! NOTICE!</b></p> <p><b>To reset the slam-shut valve, decrease the downstream pressure (Pd) to the normal working pressure of the line and below the pressure switch calibration value.</b></p>
5	<p>Repeat steps 2-3-4 at least three times.</p> <p><b>! NOTICE!</b></p> <p><b>The calibration value must comply with the operating limits specified on the plate.</b></p>

Tab. 8.71.

**SPRING SETTING FOR MINIMUM PRESSURE TRIPPING (IF PRESENT)**

Step	Action
1	Partially open the drain cock (Fig. 8.29, ref.6) to the atmosphere and keep it open for the next steps.
	Decrease the downstream pressure to the minimum required slam-shut device pressure by turning the main regulator's pilot adjustment screw.
2	<div style="border: 1px solid black; padding: 5px;">  <b>NOTICE!</b> </div> <p><b>Check the pressure referring to the downstream pressure gauge (Fig. 8.29, ref. 5).</b>  <b>If the slam-shut valve:</b></p> <ul style="list-style-type: none"> <li>• <b>trips before the expected pressure value: unscrew (anti-clockwise) the adjustment ring nut (15) so as to relieve the spring (17);</b></li> <li>• <b>does not trip before the expected pressure value, screw in (clockwise) the adjustment ring nut (15) so as to further compress the spring (17).</b></li> </ul>
3	Move the lock into the open position by means of the reset lever (16) and keep it open manually.
4	Increase the downstream pressure up to the regulator setting value by acting on the pilot adjustment screw (10) (Fig. 8.29, ref. 3) of the main regulator (Fig. 8.29, ref. 1).
5	Reset the slam-shut valve.
6	Check the minimum pressure spring for proper calibration by repeating steps 1-2-3-4 at least three times.
7	Close the bleed cock (Fig. 8.29, ref.6).

*Tab. 8.72.*

## 8.9 - COMMISSIONING PROCEDURE FOR THE REFLUX 819/FO REGULATOR WITH INCORPORATED SLAM-SHUT VALVE SB/97

### 8.9.1 - CHECKING THE HB/97 INCORPORATED SLAM-SHUT VALVE FOR SEALING WHEN CLOSING

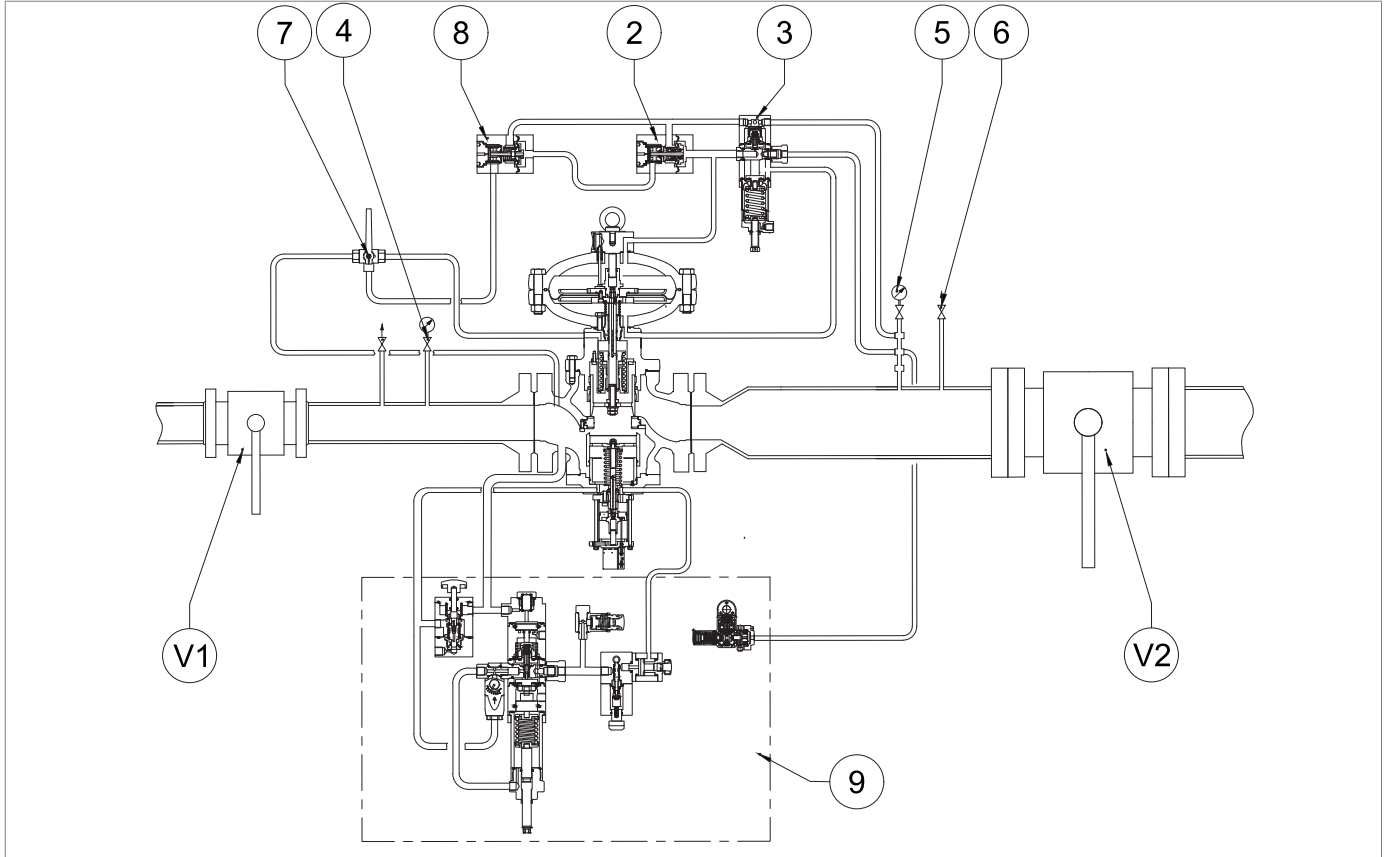

Fig. 8.35. Sealing of the HB/97 slam-shut valve when closing

Step	Action
1	Check that the slam-shut valve (3) is in the closed position.
2	Open the drain cock (6) and drain the downstream section completely.
3	Open the upstream valve (V1) very slowly.
4	Check the tightness of the slam-shut valve (3) through the pilot unit's power connection (2) located under the main regulator's control head (1), disconnecting the connection from the regulator. <div style="border: 1px solid blue; padding: 5px; margin-top: 5px;"> <p><b>! NOTICE!</b></p> <ul style="list-style-type: none"> <li>• Check the seal with a foaming substance;</li> <li>• In case of leaks an action, please refer to the chapter "10 - Troubleshooting" to clear the causes of malfunctions.</li> </ul> </div>
5	Reconnect the power connection of the drive unit (2). <div style="border: 1px solid blue; padding: 5px; margin-top: 5px;"> <p><b>! NOTICE!</b></p> <p><b>Check whether to replace the fitting by referring to the fitting manufacturers instructions.</b></p> </div>

Tab. 8.73.

## 8.9.2 - COMMISSIONING OF THE REFLUX 819/FO REGULATOR WITH HB/97 SLAM-SHUT VALVE

For the following procedure, please refer to Fig. 8.35 at “8.9.1 - Checking the HB/97 incorporated slam-shut valve for sealing when closing”:

Step	Action
1	Make sure that the bleed cock (6) is partially open.
2	<p>Check that the slam-shut valve is in the shut-off position.</p> <p><b>! NOTICE!</b>  <b>If the slam-shut valve is in the open position, close it using the manual button (Fig. 8.38, ref.10).</b></p>
3	Set the 3-way valve (7) to the by-pass position.
4	<p>Check that the regulator is fully shut off (0%) by checking the position of the stroke indicator rod (Fig. 4.1).</p> <p><b>! NOTICE!</b>  <b>Check the pressure referring to the pressure gauge (5) located upstream.</b></p>
5	Partially open the upstream shut-off valve (V1), checking the pressure indicated by the upstream pressure gauge (4).
6	Set the 3-way valve (7) to the operating position.
7	<p>Perform the internal tightness check of the LA slam-shut valve, referring to chapter 8.9.1.</p> <p><b>! NOTICE!</b>  <b>In case of leaks, refer to chapter 10 “Troubleshooting” to clear the causes of the malfunctions.</b></p>
8	Slowly pressurise the control line by pressing the HP2/2 by-pass button (7.1) on the slam-shut valve, checking that the downstream pressure (Pd) indicated by the downstream pressure gauge (5) does not exceed the required calibration value by more than 50%.
9	<p>When the regulator is put into service, the pressure on the downstream pressure gauge (5) will be equal to the calibration value of the main regulator.</p> <p><b>! NOTICE!</b>  <b>In the first line pressurisation phase, the pressure on the downstream pressure gauge (5) could exceed the required calibration value, depending on the response time of the regulator.</b></p>
10	Open the upstream shut-off valve (V1) completely.
11	Check the calibrations of the LINE-OFF 2.0 slam-shut valve by referring to section 8.9.3.
12	<p><b>a - FOR INITIAL COMMISSIONING OF THE REGULATION LINE</b>            If the pressure downstream (Pd) is not at the required calibration value, proceed as follows:</p> <ul style="list-style-type: none"> <li>• value of the downstream pressure (Pd) is lower than the required calibration value: load the pilot calibration spring (3) by turning the adjustment screw Fig. 8.37(, ref.10) clockwise</li> <li>• value of the downstream pressure (Pd) is higher than the required calibration value: unload the pilot calibration spring (3) by turning the adjustment screw (Fig. 8.37, ref.10) clockwise</li> </ul> <p><b>b - AFTER MAINTENANCE OF THE REGULATION LINE</b></p> <ul style="list-style-type: none"> <li>• load the pilot setting spring (3) by turning the adjustment screw, (Fig. 8.37, ref.10) clockwise to increase the regulator pressure value (1)</li> </ul>
13	Check the downstream pressure (Pd) referring to the downstream pressure gauge (5).
14	Close the bleed cock (6).

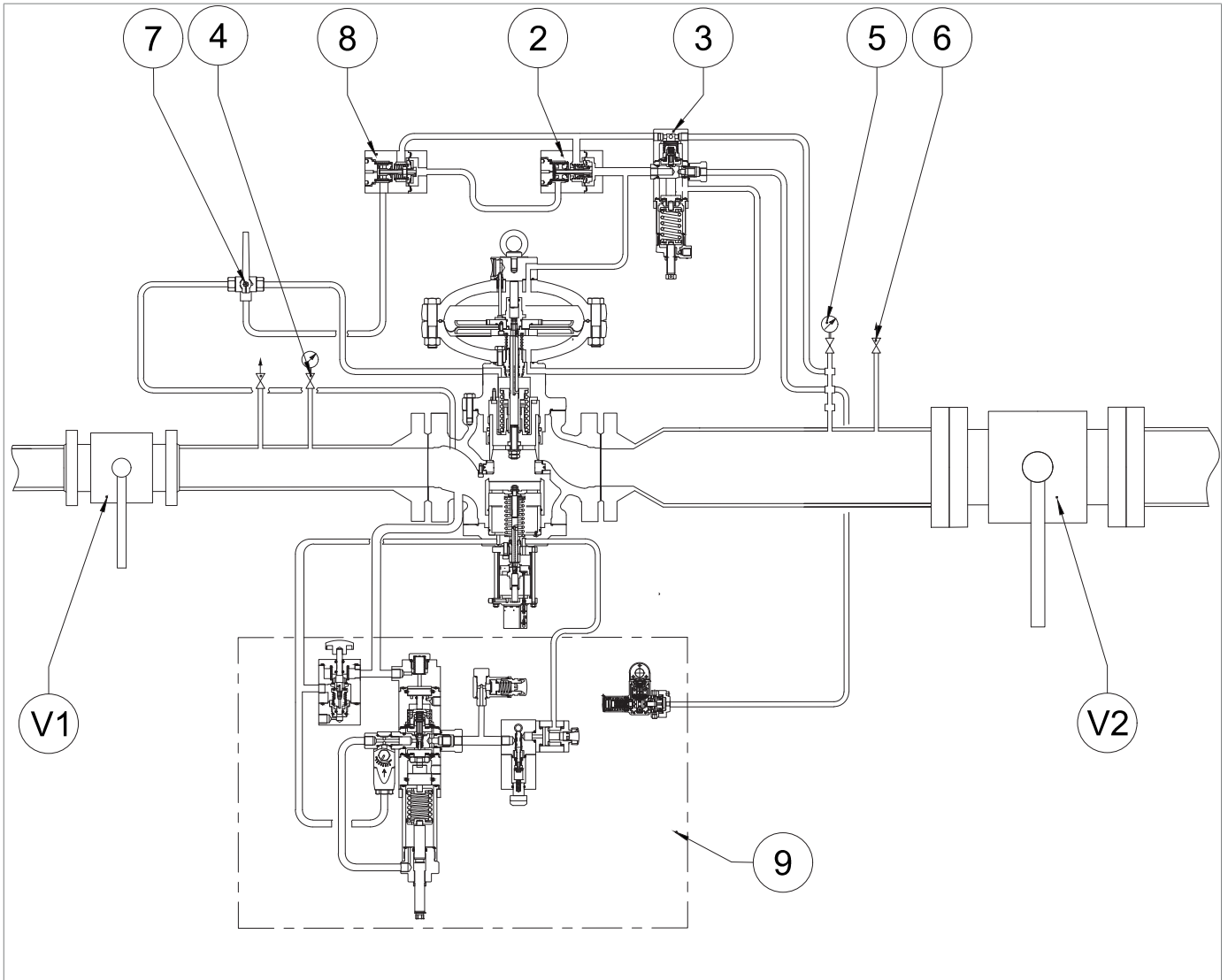

Fig. 8.35. Sealing of the HB/97 slam-shut valve when closing

Step	Action
15	<p>Check that the downstream pressure (Pd), after an increment phase, does not exceed the closing pressure value (refer to the SG value displayed on the plate, see par. 2.8).</p> <p><b>! NOTICE!</b></p> <p><b>If the pressure in the pipe section between the regulator and the downstream shut-off valve (V2) exceeds the closing pressure value, consult chapter “10 - Troubleshooting” to clear the causes of the malfunctions.</b></p>
16	<p>Check the tightness of all the fittings between the shut-off valves (V1, V2).</p> <p><b>! NOTICE!</b></p> <p><b>Check for sealing with a foaming substance.</b></p>
17	<p>If external leaks are found, eliminate the leak points and repeat the procedure from step 7.</p>
18	<p>Open downstream shut-off valve (V2) very slowly until the pipeline fills completely.</p> <p><b>! NOTICE!</b></p> <p><b>If the pressure of the downstream pipeline is lower than the calibration pressure, partially open the downstream shut-off valve (V2) so as to not to exceed the maximum flow rate value of the installation.</b></p>

Tab. 8.74.

**8.9.3 - LINE OFF 2.0 COMMISSIONING AND CALIBRATION PROCEDURE FOR HB/97 BUILT-IN SLAM-SHUT VALVE**

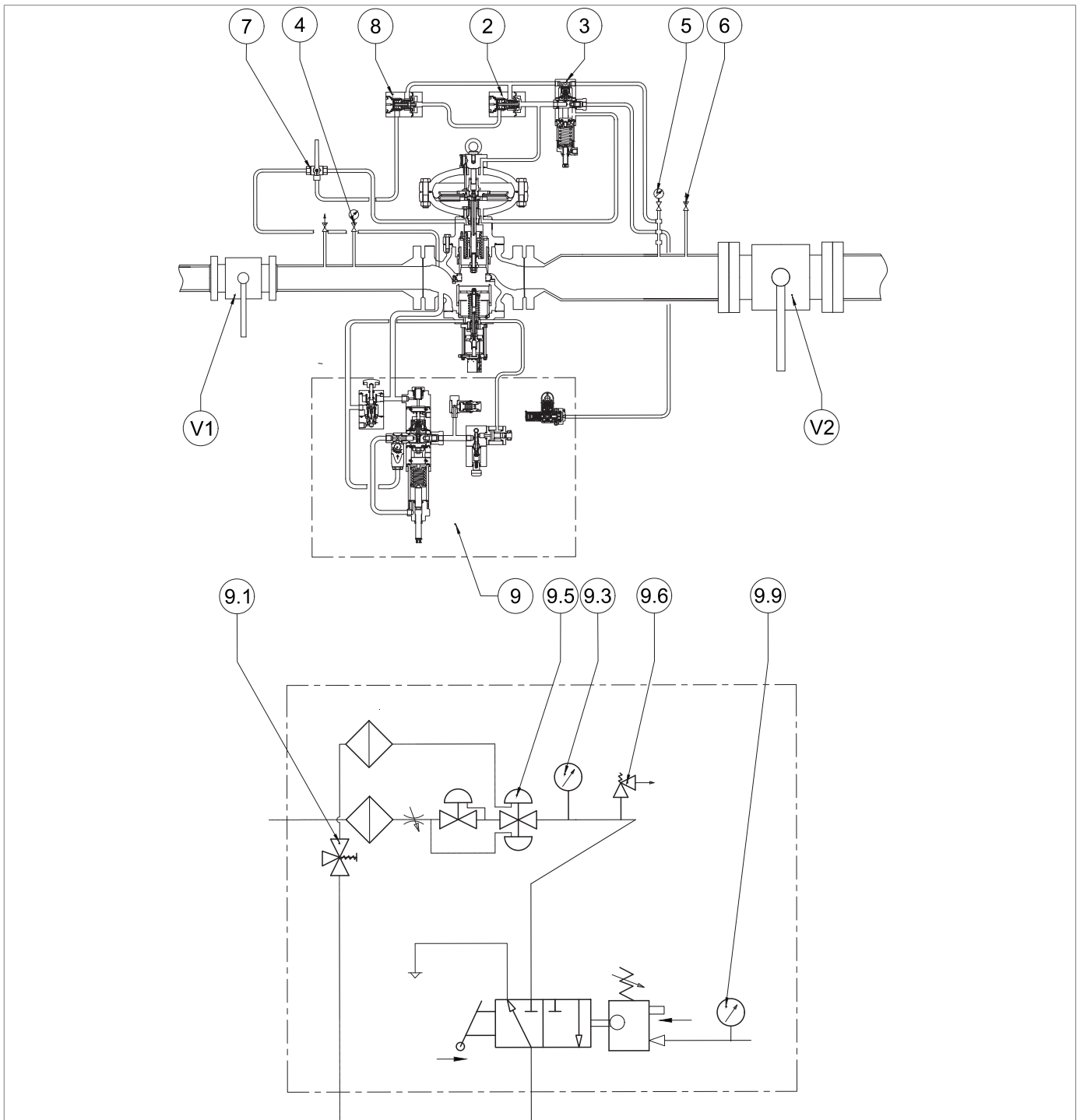



Fig. 8.36. LINE OFF 2.0 commissioning and calibration for the HB/97 built-in slam-shut valve

Step	Action
1	Press and hold the button of the bypass valve HP2/2 (9.1) to: <ul style="list-style-type: none"> <li>bring the upstream pressure to the power supply unit of the LINE-OFF 2.0 device;</li> <li>balance the pressure of the HB/97 built-in slam-shut valve plug.</li> </ul>
2	Release the button of bypass valve HP2/2 (9.1) after checking that the upstream and downstream pressure of the slam-shut valve is balanced.
3	Turn the adjusting screw of the R44/SS regulator (9.5) clockwise and tighten it until reaching the tripping value (6 bar) of the safety valve VS/FI (9.6). <div style="border: 1px solid blue; padding: 5px; margin-top: 10px;">  <b>NOTICE!</b>  <b>Check the pressure, referring to the pressure gauge (9.3) connected to the R44/SS regulator.</b> </div>
4	If the safety valve VS/FI (7.6): <ul style="list-style-type: none"> <li>opens before the expected pressure value, unscrew the shaft collar nut and tighten (clockwise) the adjustment plug so that the spring inside it is further compressed;</li> <li>does not open at the expected pressure value, unscrew the shaft collar nut and loosen the adjustment plug anti-clockwise, so as to release the spring inside.</li> </ul>
5	Check the VS/FI valve (9.6) for correct calibration: <ul style="list-style-type: none"> <li>decreasing the pressure by adjusting the adjusting screw of the R44/SS regulator (9.5);</li> <li>increasing the pressure until the VS/FI valve (9.6) trips by turning the adjusting screw of the R44/SS regulator (9.5).</li> </ul> <div style="border: 1px solid blue; padding: 5px; margin-top: 10px;">  <b>NOTICE!</b>  <b>Repeat the step at least three times.</b> </div>
7	By turning the adjusting screw, calibrate the R44/SS regulator (9.5) to the required pressure value (min. 4 bar, max. 5 bar) referring to the connected pressure gauge (9.3), then: <ul style="list-style-type: none"> <li>if the pressure value on the pressure gauge is lower than the set value of the R44/SS regulator (9.5): tighten the adjusting screw clockwise so as to further compress the spring inside it;</li> <li>if the pressure value on the pressure gauge is higher than the calibration value of the R44/SS regulator (9.5): unscrew the adjusting screw anti-clockwise so as to further release the spring inside.</li> </ul>
8	Press the button of bypass valve HP2/2 (9.1) and check that the upstream and downstream pressure is balanced.
9	Release the HP2/2 bypass valve button (9.1).
10	Reset the HB/97 slam-shut valve by operating the lever (9.9).

Tab. 8.75.

## COMMISSIONING THE REGULATOR

 **NOTICE!**

Refer to paragraph “8.5 - Regulator commissioning procedure”.

### 8.10 - CALIBRATION OF THE PRESSURE SWITCH FOR LINE OFF 2.0

 **NOTICE!**

For the pressure switch calibration procedure, please refer to “8.8.3 - Calibration procedure for pressure switches Models 102M/102MH ÷ 105M/105MH”.

## 8.11 - DEVICE CALIBRATION

### 8.11.1 - 200/A/FO AND 200/A SERIES PILOTS AND THE M/A THROTTLE VALVE

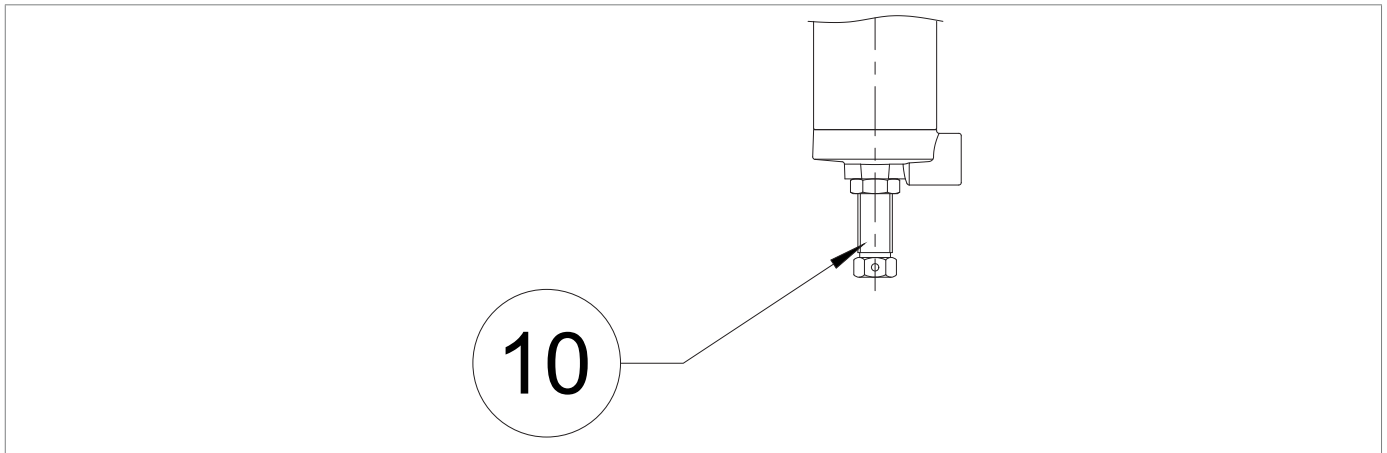

Fig. 8.37. 200/A/FO and 200/A series pilots

Turn the adjusting screw (10):

- anticlockwise to decrease the adjusted pressure;
- clockwise to increase the adjusted pressure.

### 8.11.2 - PRESSURE SWITCHES MODELS 102M/102MH - 105M/105MH

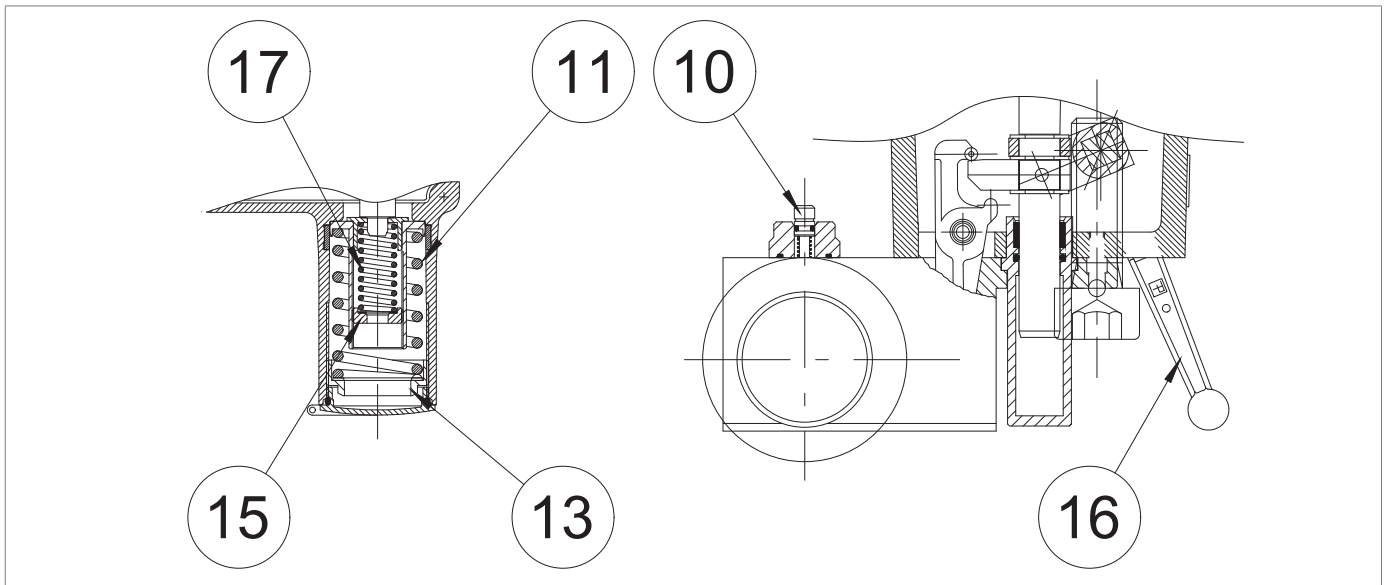

Fig. 8.38. Pressure switches models 102M/102MH - 105M/105MH

Turn on the maximum ring nut (13):

- anti-clockwise to decrease the slam-shut device tripping pressure;
- clockwise to increase the slam-shut device tripping pressure.

Turn the minimum ring nut (15):

- anti-clockwise to decrease the slam-shut device tripping pressure;
- clockwise to increase the slam-shut device tripping pressure.

**! NOTICE!**

**For calibration ranges, please refer to chapter "13 - Calibration tables".**

## 9 - MAINTENANCE AND FUNCTIONAL CHECKS

### 9.1 - GENERAL WARNINGS

#### HAZARD!

- Maintenance work must be carried out by qualified personnel trained on safety in the workplace and authorised to carry out equipment-related activities.
- Repair or maintenance work not provided for in this manual may be carried out only if approved by PIETRO FIORENTINI S.p.A.. No liability for personal injury or damage to property can be attributed to PIETRO FIORENTINI S.p.A. for work other than that described or performed in a manner other than indicated.

#### WARNING!

Before any intervention, it is necessary:

- to ensure that the line on which the equipment is installed is shut off upstream and downstream;
  - to operate the slam shut valve in manual mode by pressing the release button (Pos. 10 - Figure 4.13.).
- Next, check that the pressure indicated by the pressure gauge installed on the LINE OFF 2.0 device (Pos. 9.3 - Figure 8.36.) is 0 bar, ensuring complete depressurisation of the line.

#### WARNING!

In case of doubt, do not perform any work. Contact PIETRO FIORENTINI S.p.A. for the necessary clarifications.

The management and/or use of the equipment includes interventions that are necessary as a result of normal use such as:

- inspection and checks;
- functional checks;
- routine maintenance;
- special maintenance.

#### NOTICE!

Maintenance work is strictly related to:

- the quality of the conveyed gas (impurities, humidity, gasoline, corrosive substances);
- the effectiveness of filtration;
- the conditions of use of the equipment.

To properly run the equipment, one should:

- follow the service frequency referred to in the manual for functional checks and routine maintenance.
- not exceed the time interval between one service and the next. The time interval is to be understood as the maximum acceptable; it can, however, be shortened;
- promptly check the causes of any anomalies such as excessive noise, leakage of fluids or similar and remedy them. The timely removal of any causes of anomaly and/or malfunction prevents further damage to the equipment and ensures operator safety;

Before beginning disassembly of the equipment, make sure that:

- the spare parts and parts used in replacements have adequate requirements to ensure the original performance of the equipment. Use recommended original spare parts;
- the operator must have the necessary equipment (see chapter “7 - Commissioning/maintenance equipment”).

 **NOTICE!**

**The recommended spare parts are unambiguously identified with tags indicating:**

- **the assembly drawing number of the equipment in which they are to be used (see chapter “12 - Recommended spare parts”);**
- **the position shown in the assembly drawing of the equipment.**

The equipment maintenance operations are divided, from an operational point of view, into three main categories:

Commissioning and maintenance operations	
<b>Periodic checks and inspections</b>	All those checks that the operator must carry out on a regular basis to ensure that the equipment is in proper working order.
<b>Routine maintenance</b>	<p>All those operations that the operator must preventively carry out to ensure proper operation of the device over time. Routine maintenance includes:</p> <ul style="list-style-type: none"> <li>• inspection;</li> <li>• control;</li> <li>• adjustment;</li> <li>• cleaning;</li> <li>• lubrication;</li> <li>• replacement;</li> </ul> <p>of all spare parts.</p>
<b>Special maintenance</b>	<p>All those operations to be carried out by the operator when the equipment requires them.</p> <div style="background-color: #c00000; color: white; padding: 5px; display: flex; align-items: center;">  <b>HAZARD!</b> </div> <p><b>Special maintenance:</b></p> <ul style="list-style-type: none"> <li>• <b>requires extensive and specialised knowledge of the machines, operations required, risks involved and correct procedures to operate safely;</b></li> <li>• <b>must be provided by qualified, trained and authorised technicians.</b></li> </ul>

Tab. 9.76

## 9.2 - PERIODICALLY CHECKING AND INSPECTING THE EQUIPMENT FOR PROPER OPERATION

Periodic checks and inspections	
<b>Operator qualification</b>	Mechanical maintenance technician
<b>PPE required</b>	 <div style="background-color: orange; padding: 5px; margin-top: 10px;"> <p><b>⚠ WARNING!</b></p> <p>The PPE listed in this table is related to the risk associated with the equipment. For the required PPE to protect against risks associated with the workplace, installation or operating conditions, please refer to:</p> <ul style="list-style-type: none"> <li>the regulations in force in the country of installation;</li> <li>any information provided by the Safety Manager at the installation facility.</li> </ul> </div>

Tab. 9.77

Tab. 9.78 lists the checks and inspections, i.e. the operations that do not require any manual service on the equipment. Some items thereof can be replaced remotely using suitable remote control tools:

Activity description	Equipment/accessories involved	Evaluation criterion	Minimum frequency
<b>Control of significant performance*</b>	Pressure regulators	<ul style="list-style-type: none"> <li>No fluctuations in the adjusted pressure.</li> <li>Significant pressure values within pre-set limits.</li> </ul>	Monthly
	Gas flow slam-shut type safety devices (external position indicator)	<ul style="list-style-type: none"> <li>Fully open position.</li> </ul>	
	Stand-by monitor (external position indicator)	<ul style="list-style-type: none"> <li>Fully open position.</li> </ul>	
<b>Visual inspection of external status of the equipment</b>	All	<ul style="list-style-type: none"> <li>No visible damage.</li> <li>External surface protection as per UNI 9571-1:2012.</li> </ul>	Half-yearly

Tab. 9.78

\* These checks may be carried out remotely if there is a remote control system capable of analysing the significant performance of the equipment and of sending alerts/alarms when pre-set thresholds are reached.

## 9.3 - ROUTINE MAINTENANCE

### 9.3.1 - GENERAL SAFETY WARNINGS

#### **HAZARD!**

- Put the equipment in a safe condition (close the downstream and then the upstream shut-off valve, drain the equipment completely and lastly drain the line);
- Ensure that the pressure upstream and downstream of the equipment is 0.

#### **WARNING!**

Before any intervention, it is necessary:

- to ensure that the line on which the equipment is installed is shut off upstream and downstream;
  - to operate the slam shut valve in manual mode by pressing the release button (Pos. 10 - Figure 4.13.).
- Next, check that the pressure indicated by the pressure gauge installed on the LINE OFF 2.0 device (Pos. 9.3 - Figure 8.36.) is 0 bar, ensuring complete depressurisation of the line.

#### **NOTICE!**

Before installing new sealing elements (o-rings, diaphragm, etc.), their integrity must be checked.

### 9.3.2 - REPLACEMENT FREQUENCY FOR COMPONENTS SUBJECT TO WEAR

**NOTICE!**

The following provisions shall apply to equipment components only.

The non-metallic parts of the equipment concerned are divided into the following two categories:

Preventive maintenance work	
<b>Category 1</b>	Covers parts subject to wear and/or abrasion, where: <ul style="list-style-type: none"> <li>wear and tear means the normal degradation of a part after prolonged use under normal operating conditions;</li> <li>abrasion is the mechanical action on the surface of the affected part resulting from the passage of gas under normal operating conditions.</li> </ul>
<b>Category 2</b>	takes into account parts subject to aging only, including parts that also require lubrication and/or cleaning.

Tab. 9.79

**NOTICE!**







Check, within the minimum frequency specified in “Tab. 9.80”, the available components for wear/abrasion/aging.

Category	Part description	Evaluation criterion	Minimum replacement frequency
1	Valve seat sealing rings and non-metallic plugs	Pressure regulators	6 years
		Safety devices	
		Pressure safety system equipment	
1	Non-metallic parts with internal sealing function of valve seats and accessories of individual equipment	Pilots	6 years
		Pre-regulators	
		Accelerators	
1	Non-metallic parts with a sealing function between parts, at least one of which is in motion under normal working/operating conditions	Any others	6 years
		Pressure regulators	
		Gas flow slam-shut type safety devices	
1	Non-metallic parts with sealing function involved in disassembly operations during maintenance	Relief devices with discharge to atmosphere	6 years
		Equipment subject to maintenance	
2	Non-metallic parts providing feedback (sensing elements) of the controlled pressure of safety equipment.	Safety equipment and/or accessories	6 years
2	Non-metallic parts with sealing and performance functions (diaphragms) of equipment	Pressure regulators and accessories	6 years
		Gas flow slam-shut type safety devices	6 years
		Relief device with discharge to atmosphere	6 years
2	Non-metallic parts of equipment with an internal sealing function: under normal operating conditions during maintenance	Relief valves	6 years
		Regulation lines disconnection equipment	In the presence of ascertained leaks

Category	Part description	Evaluation criterion	Minimum replacement frequency
2	Non-metallic parts with a static sealing function only	Various equipment	In the presence of ascertained leaks
2	Lubricating parts	Shut-off valves	Yearly
		Other equipment	Yearly
2	Filter elements	Filters	As needed

Tab. 9.80

## 9.4 - ROUTINE MAINTENANCE PROCEDURES

Routine maintenance	
<b>Operator qualification</b>	Mechanical maintenance technician
<b>PPE required</b>	<div style="display: flex; justify-content: space-around; align-items: center;">      </div> <div style="background-color: #f4a460; padding: 5px; margin-top: 5px;">  <b>WARNING!</b> </div> <p>The PPE listed in this table is related to the risk associated with the equipment. For the required PPE to protect against risks associated with the workplace, installation or operating conditions, please refer to:</p> <ul style="list-style-type: none"> <li>the regulations in force in the country of installation;</li> <li><u>any information provided by the Safety Manager at the installation facility.</u></li> </ul>
<b>Equipment required</b>	Please refer to the chapter “7 - Commissioning/maintenance equipment”.

Tab. 9.81

**9.4.1 - TIGHTENING TORQUES REFLUX 819/FO**

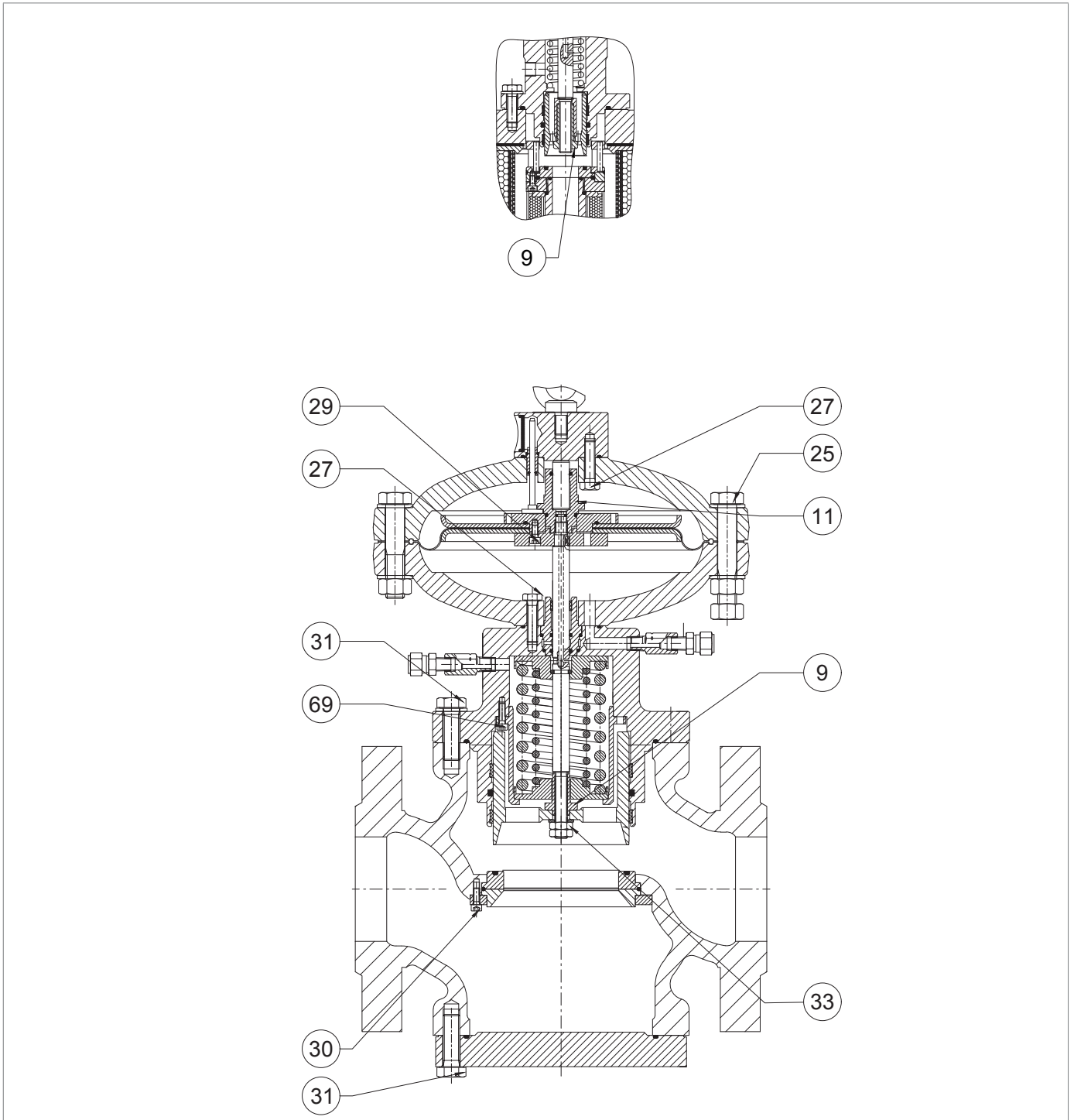

*Fig. 9.39. Tightening torques REFLUX 819/FO*

**REFLUX 819/FO (+LDB/171) 1"**

Pos.	Description	Torque (nm)	Torque (ft - lb)
9	Locking nut M12	35	25
11	M12 piston guide	35	25
25	Screw M16X70 UNI 5737	60	44
27	Screw M10X35 UNI 5739	45	33
29	Screw M6X14 UNI 5931	10	7
30	Screw M6X12 UNI 5931	10	7
31	Screw M10X30 UNI 5739	45	33

*Tab. 9.82*
**REFLUX 819/FO (+LDB/171) 2"**

Pos.	Description	Torque (nm)	Torque (ft - lb)
9	Locking nut M12	35	25
11	M1225 piston guide	35	25
25	Screw M16X70 UNI 5737	60	44
27	Screw M10X35 UNI 5739	45	33
29	Screw M6X14 UNI 5931	10	7
30	Screw M6X12 UNI 5931	10	7
31	Screw M12X35 UNI 5739	80	59

*Tab. 9.83*
**REFLUX 819/FO (+LDB/171) 3"**

Pos.	Description	Torque (nm)	Torque (ft - lb)
9	Locking nut M12	35	25
11	M12 piston guide	35	25
25	Screw M18X90 UNI 5737	70	44
27	Screw M10X35 UNI 5737	45	33
29	Screw M6X14 UNI 5931	10	7
30	Screw M6X16 UNI 5931	10	7
31	Screw M12X40 UNI 5739	80	59
33	Nut M12 UNI 5589	35	25

*Tab. 9.84*

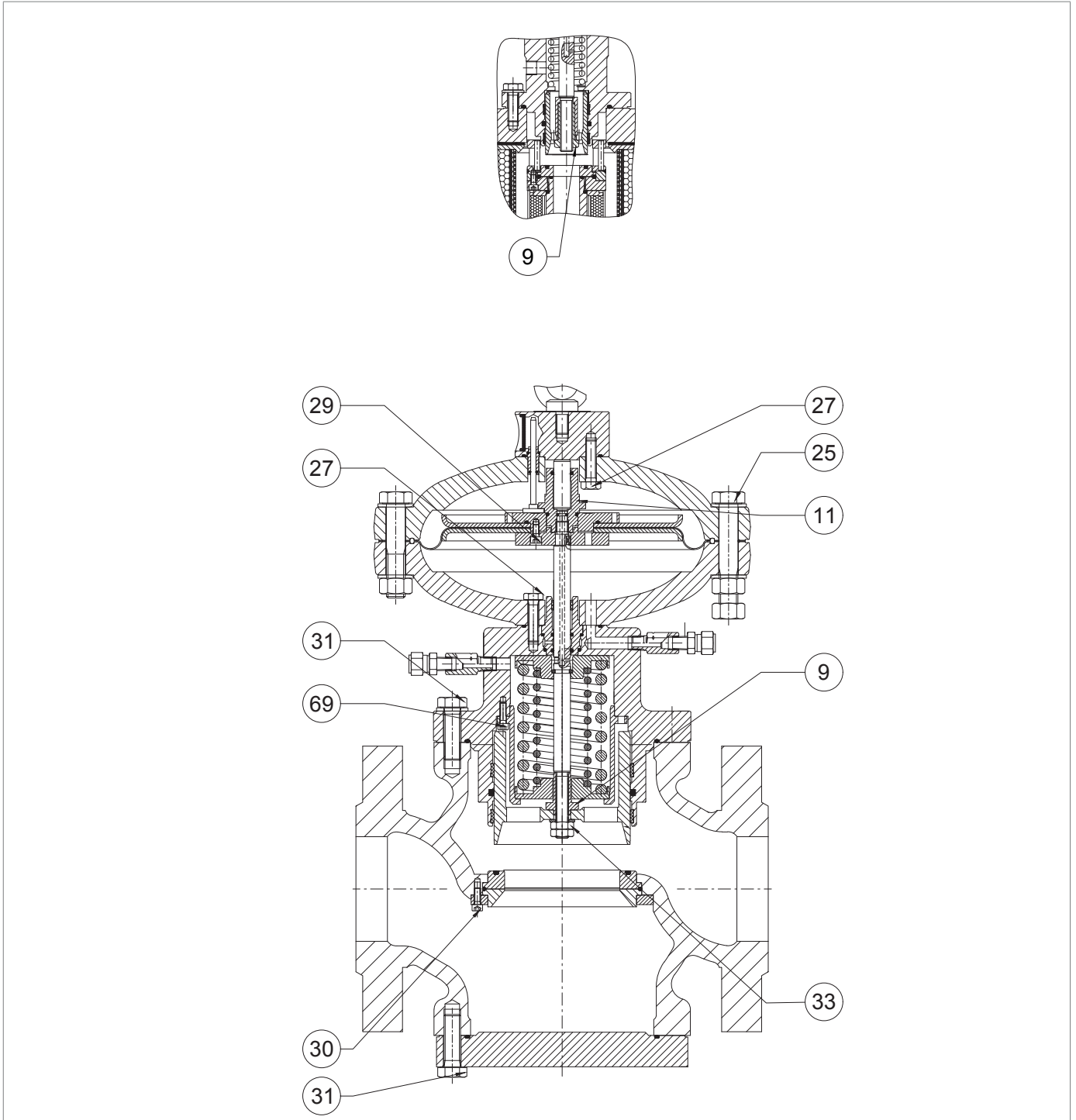

*Tightening torques REFLUX 819/FO*

**REFLUX 819/FO**

**REFLUX 819/FO (+LDB/171) 4"**

Pos.	Description	Torque (nm)	Torque (ft - lb)
9	Locking nut M12	35	25
11	M12 piston guide	35	25
25	Screw M16X70 UNI 5737	70	44
27	Screw M10X40 UNI 5739	45	33
29	Screw M6X14 UNI 5931	10	7
30	Screw M6X16 UNI 5931	10	7
31	Screw M16X50 UNI 5737	150	110
33	Nut M12 UNI 5589	35	25

*Tab. 9.85*
**REFLUX 819/FO (+LDB/171) 6"**

Pos.	Description	Torque (nm)	Torque (ft - lb)
9	Locking nut M24	110	81
11	Piston guide M18	110	81
25	Screw M22X120 UNI 5737	140	103
27	Screw M14X50 UNI 5931	115	84
29	Screw M6X16 UNI 5931	10	7
30	Screw M6X16 UNI 5931	10	7
31	Screw M20X70 UNI 5737	250	184
33	Nut M18 UNI 5589	110	81

*Tab. 9.86*
**REFLUX 819/FO (+LDB/171) 8"**

Pos.	Description	Torque (nm)	Torque (ft - lb)
9	Locking nut M24	110	81
11	Piston guide M18	110	81
25	Screw M22X120 UNI 5737	140	103
27	Screw M14X50 UNI 5737	115	84
29	Screw M6X16 UNI 5931	10	7
30	Screw M6X16 UNI 5931	10	7
31	Screw M22X70 UNI 5737	280	206
33	Nut M18 UNI 5589	110	81

*Tab. 9.87*

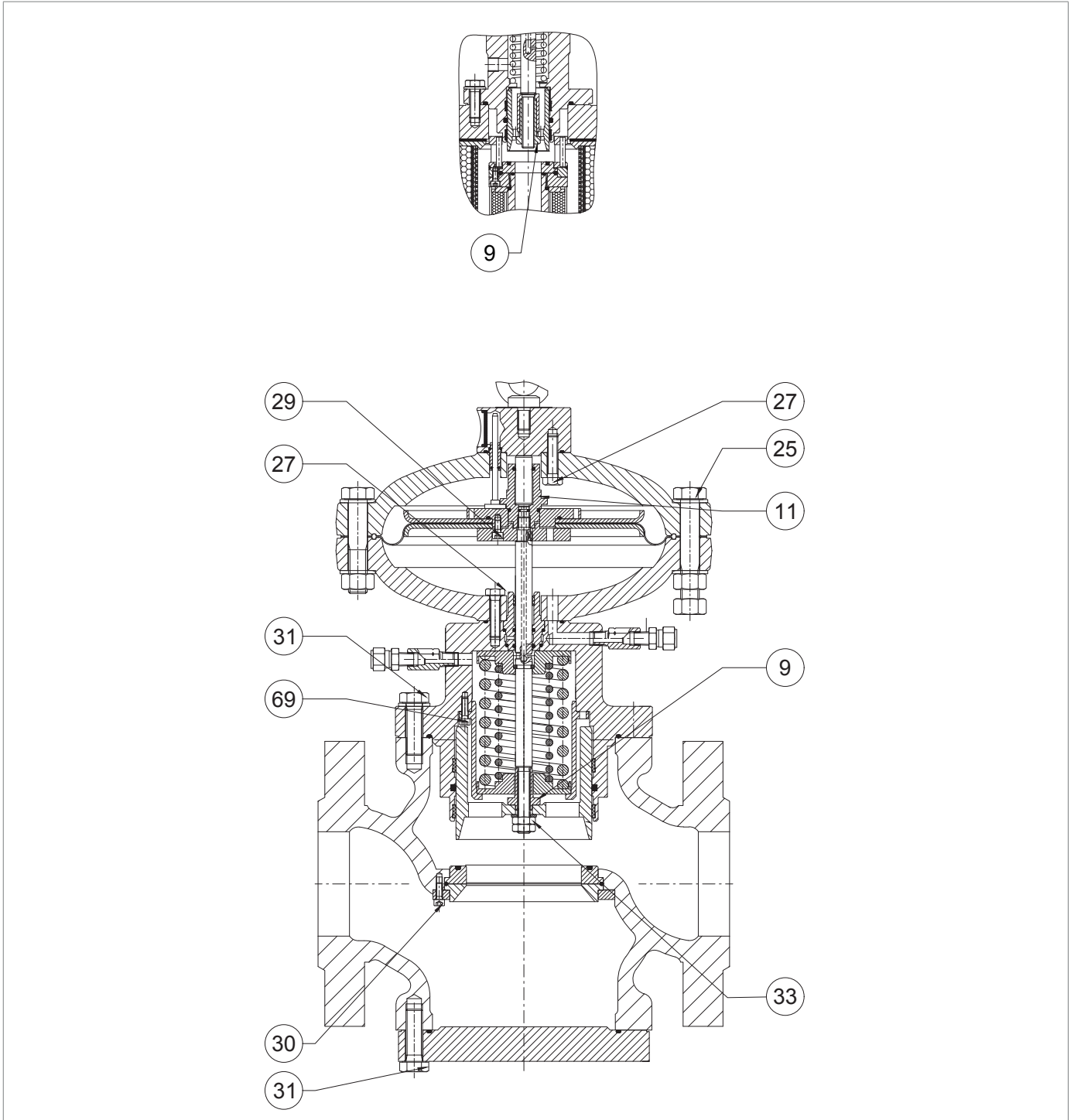

Tightening torques REFLUX 819/FO

**REFLUX 819/FO (+LDB/171) 10"**

Pos.	Description	Torque (nm)	Torque (ft - lb)
9	Locking nut M30	150	110
11	M22 piston guide	150	110
25	Screw M27X150 UNI 5737	220	162
27	Screw M20X80 UNI 5737	250	184
29	Screw M6X16 UNI 5931	10	7
30	Screw M6X16 UNI 5931	10	7
31	Screw M22X70 UNI 5737	280	206
33	Nut M20 UNI 5589	150	110

*Tab. 9.88*
**REFLUX 819/FO (+LDB/171) 12"**

Pos.	Description	Torque (nm)	Torque (ft - lb)
9	Locking nut M36	180	132
11	M27 piston guide	180	132
25	Screw M27X130 UNI 5737	220	162
27	Screw M20X80 UNI 5737	250	184
27.1	Screw M20X160 UNI 5737	250	184
29	Screw M8X20 UNI 5931	20	14
30	Screw M8X20 UNI 5931	20	14
31	Screw M22x100 UNI 5737	280	206
33	Nut M27 UNI 5589	180	132

*Tab. 9.89*

9.4.1.1 - TIGHTENING TORQUES REFLUX 819/FO + SILENCER DB/819

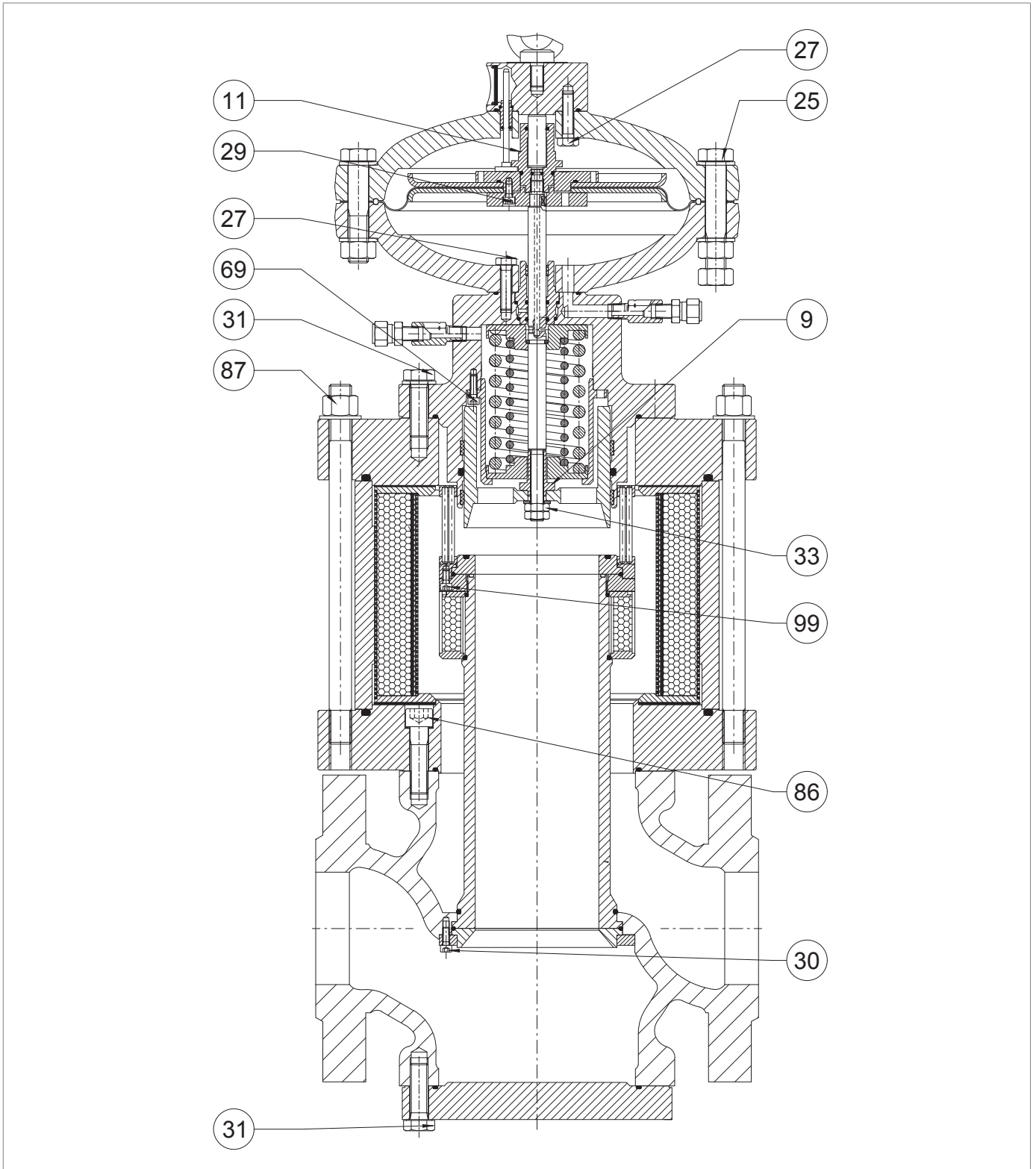

Fig. 9.40. Tightening torques REFLUX 819/FO + Silencer DB/819

**REFLUX 819/FO + DB/819 1"**

Pos.	Description	Torque (nm)	Torque (ft - lb)
9	Locking nut M12	35	25
11	M12 piston guide	35	25
25	Screw M16X70 UNI 5737	60	44
27	Screw M10X35 UNI 5739	45	33
29	Screw M6X14 UNI 5931	10	7
30	Screw M6X16 UNI 5931	10	7
31	Screw M10X30 UNI 5739	45	33
86	Screw M10X35 UNI 5931	45	33
87	Nut M14 UNI 5587	115	84
99	Screw M5X10 UNI 5931	6	4

*Tab. 9.90*
**REFLUX 819/FO + DB/819 2"**

Pos.	Description	Torque (nm)	Torque (ft - lb)
9	Locking nut M12	35	25
11	M1225 piston guide	35	25
25	Screw M16X70 UNI 5737	60	44
27	Screw M10X35 UNI 5739	45	33
29	Screw M6X14 UNI 5931	10	7
30	Screw M6X16 UNI 5931	10	7
31	Screw M10X30 UNI 5739	80	59
86	Screw M10X35 UNI 5931	80	59
87	Nut M18 UNI 5587	200	147
99	Screw M5X10 UNI 5931	10	7

*Tab. 9.91*
**REFLUX 819/FO + DB/819 3"**

Pos.	Description	Torque (nm)	Torque (ft - lb)
9	Locking nut M12	35	25
11	M12 piston guide	35	25
25	Screw M18X90 UNI 5737	70	44
27	Screw M10X35 UNI 5737	45	33
29	Screw M6X14 UNI 5931	10	7
30	Screw M6X16 UNI 5931	10	7
31	Screw M12X40 UNI 5739	80	59
33	Nut M12 UNI 5589	35	25
86	Screw M12X50 UNI 5931	80	59
87	Nut M14 UNI 5587	200	147
99	Screw M6X12 UNI 5931	10	7

*Tab. 9.92*

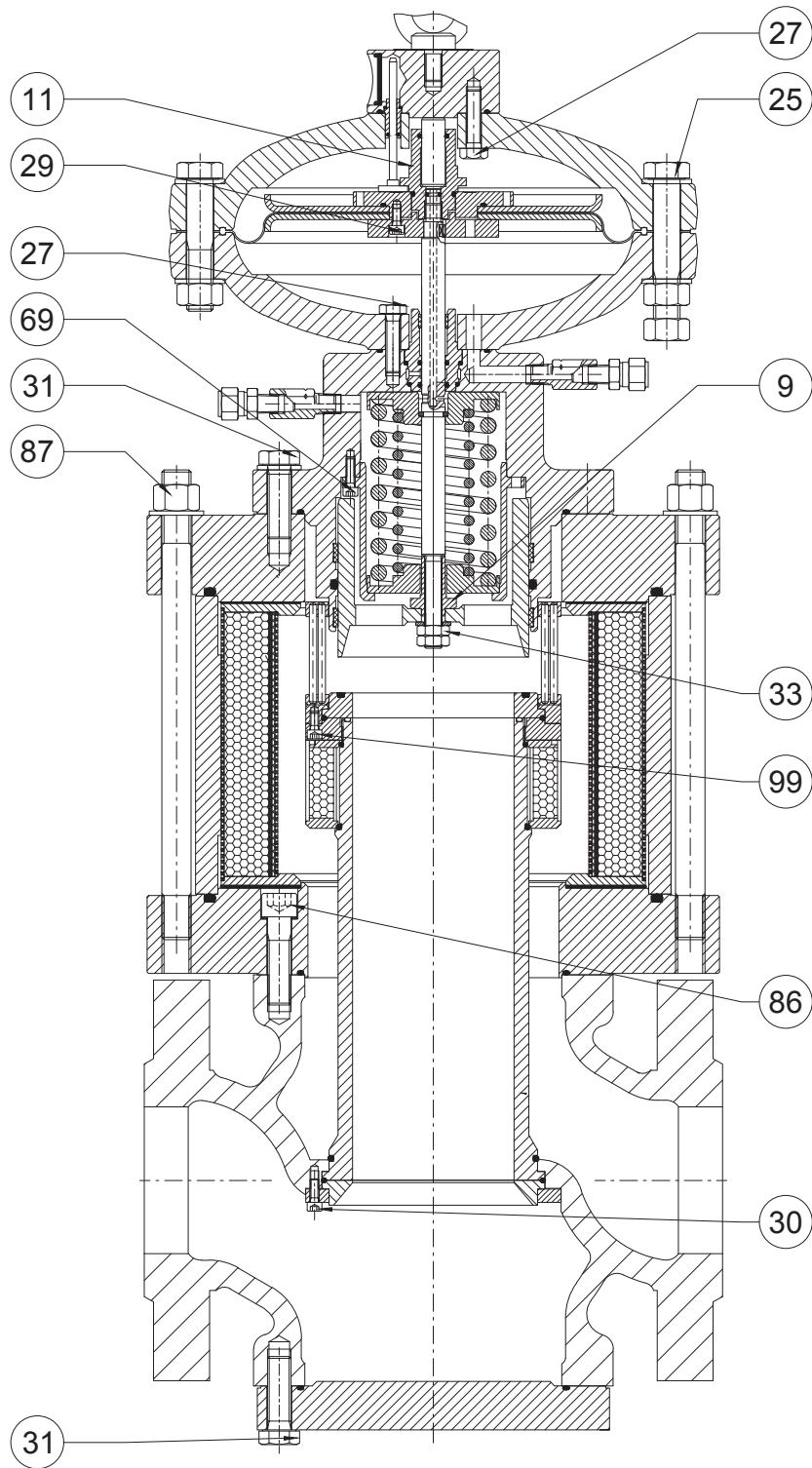

*Tightening torques REFLUX 819/FO + Silencer DB/819*

**REFLUX 819/FO + DB/819 4"**

Pos.	Description	Torque (nm)	Torque (ft - lb)
9	Locking nut M12	35	25
11	M12 piston guide	35	25
25	Screw M16X70 UNI 5737	70	44
27	Screw M10X40 UNI 5739	45	33
29	Screw M6X14 UNI 5931	10	7
30	Screw M6X16 UNI 5931	10	7
31	Screw M16X50 UNI 5737	150	110
33	Nut M12 UNI 5589	35	25
86	Screw M16X60 UNI 5931	200	147
87	Nut M20 UNI 5588	150	110
99	Screw M6X12 UNI 5931	10	7

*Tab. 9.93*
**REFLUX 819/FO + DB/819 6"**

Pos.	Description	Torque (nm)	Torque (ft - lb)
9	Locking nut M24	110	81
11	Piston guide M18	110	81
25	Screw M22X120 UNI 5737	100	73
27	Screw M14X50 UNI 5931	115	84
29	Screw M6X16 UNI 5931	10	7
30	Screw M6X16 UNI 5931	10	7
31	Screw M20X70 UNI 5737	250	184
33	Nut M18 UNI 5589	110	81
86	Screw M20X70 UNI 5931	250	184
87	Nut M22 UNI 5588	220	162
99	Screw M6X12 UNI 5931	10	7

*Tab. 9.94*
**REFLUX 819/FO + DB/819 8"**

Pos.	Description	Torque (nm)	Torque (ft - lb)
9	Locking nut M24	110	81
11	Piston guide M18	110	81
25	Screw M22X120 UNI 5737	100	73
27	Screw M14X50 UNI 5737	115	84
29	Screw M6X16 UNI 5931	10	7
30	Screw M6X16 UNI 5931	10	7
31	Screw M22X70 UNI 5737	280	206
33	Nut M18 UNI 5589	110	81
86	Screw M22X80 UNI 5931	280	206
87	Nut M24 UNI 5587	220	162
99	Screw M6X10 UNI 5931	10	7

*Tab. 9.95*

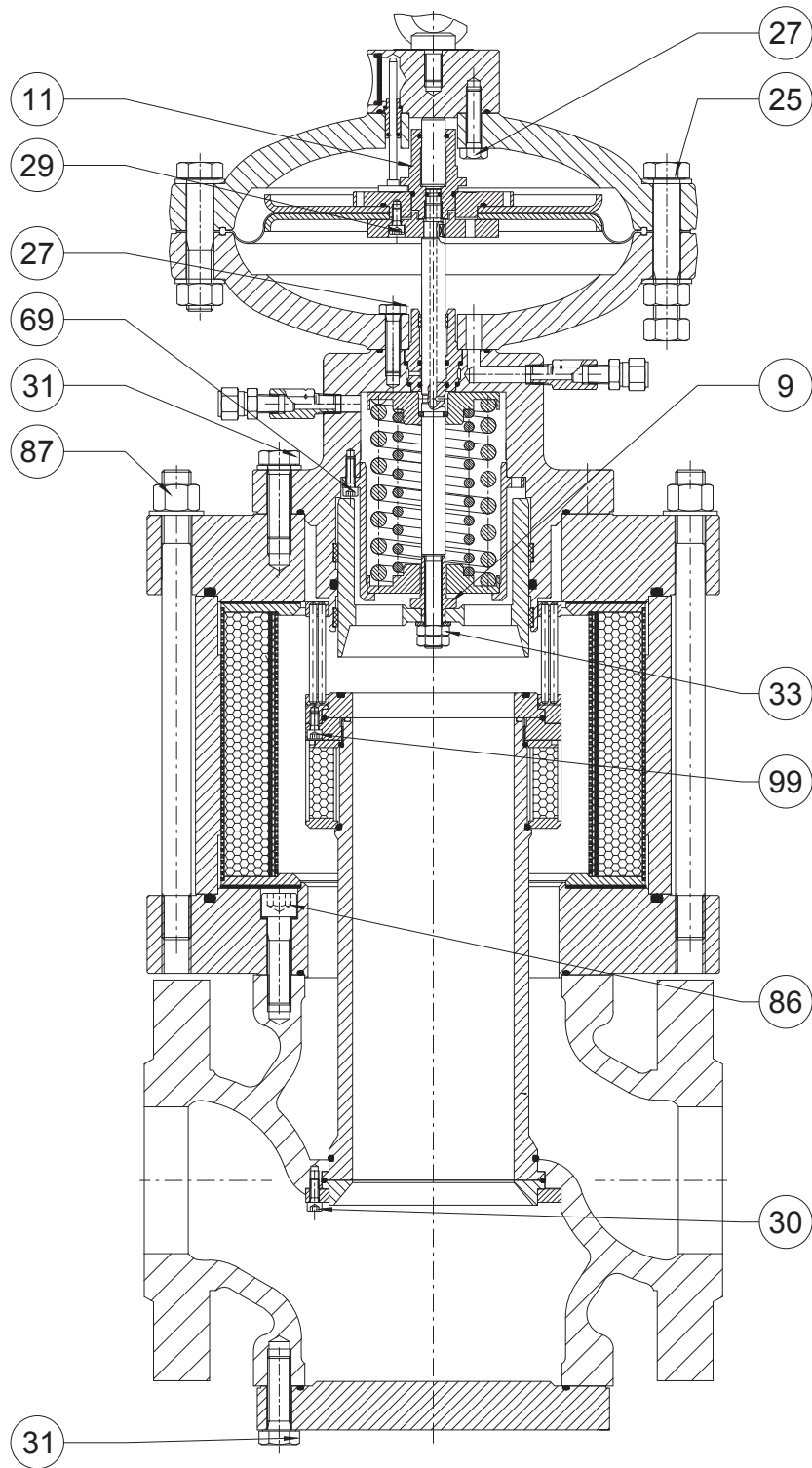

*Tightening torques REFLUX 819/FO + Silencer DB/819*

**REFLUX 819/FO + DB/819 10"**

Pos.	Description	Torque (nm)	Torque (ft - lb)
9	Locking nut M30	150	110
11	M22 piston guide	150	110
25	Screw M27X150 UNI 5737	220	162
27	Screw M20X80 UNI 5737	250	184
29	Screw M6X16 UNI 5931	10	7
30	Screw M6X16 UNI 5931	10	7
31	Screw M22X70 UNI 5737	280	206
33	Nut M20 UNI 5589	150	110
86	Screw M22X80 UNI 5931	280	206
87	Nut M24 UNI 5587	300	221
99	Screw M6X10 UNI 5931	10	7

*Tab. 9.96*
**REFLUX 819/FO + DB/819 12"**

Pos.	Description	Torque (nm)	Torque (ft - lb)
9	Locking nut M36	180	132
11	M27 piston guide	180	132
25	Screw M27X130 UNI 5737	220	162
27	Screw M20X80 UNI 5737	250	184
27.1	Screw M20X160 UNI 5737	250	184
29	Screw M8X20 UNI 5931	20	14
30	Screw M8X20 UNI 5931	20	14
31	Screw M22x100 UNI 5737	280	206
33	Nut M27 UNI 5589	180	132
86	Screw M22X110 UNI 5931	280	206
87	Nut M24 UNI 5588	300	221
99	Screw M8X20 UNI 5931	20	14

*Tab. 9.97*

### 9.4.1.2 - TIGHTENING TORQUES FOR PM/819 BUILT-IN MONITOR

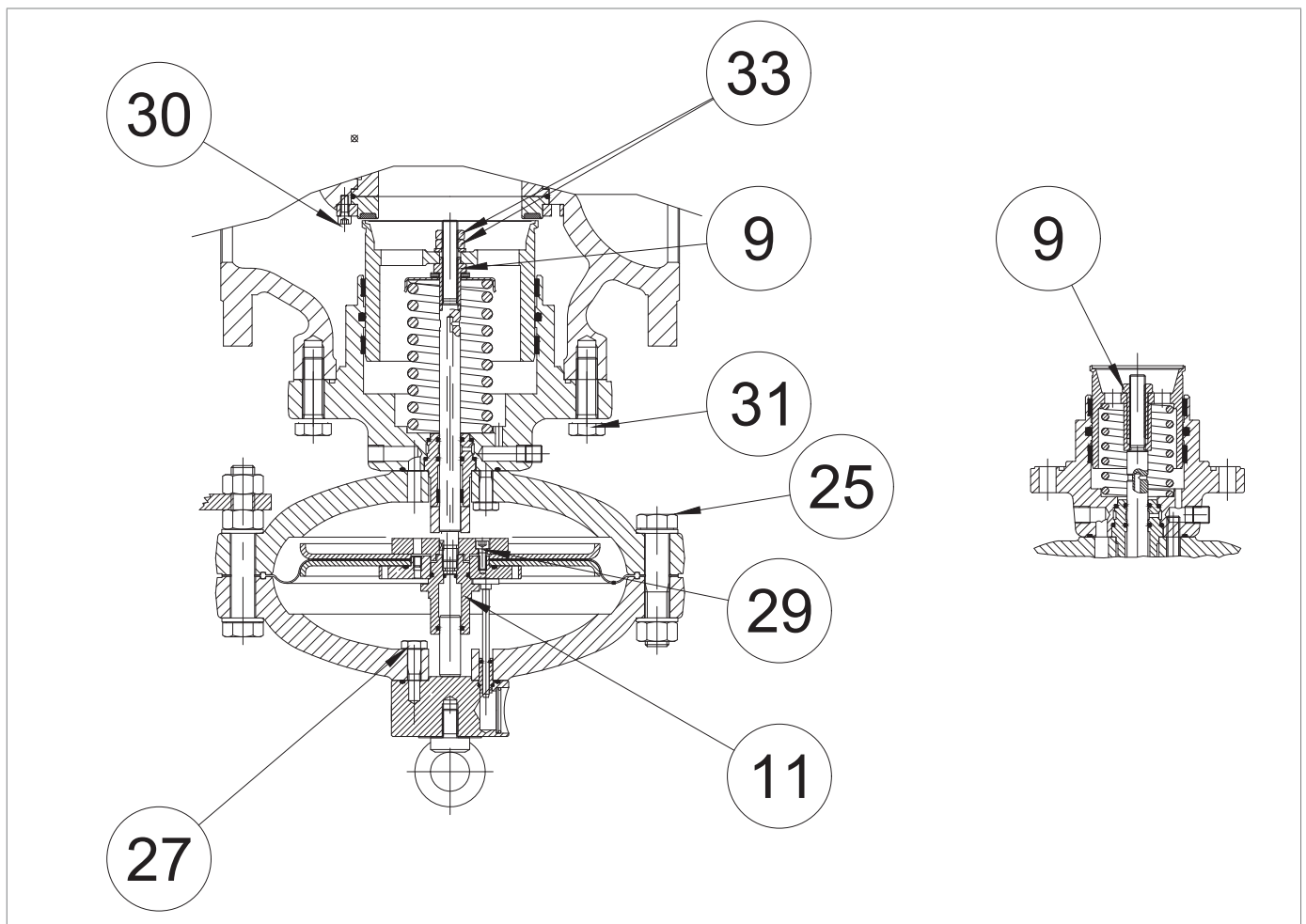

Fig. 9.41. Tightening torques for PM/819 built-in monitor

PM/819 1"			
Pos.	Description	Torque (nm)	Torque (ft - lb)
9	Nut M12	35	25
11	M12 balancing piston guide	35	25
25	Screw M16X70 UNI 5737	60	44
27	Screw M10X35 5739	45	33
29	Screw M6X14 UNI 5931	10	7
30	Screw M6X12 UNI 5931	10	7
31	Screw M10X30 UNI 5739	45	33

Tab. 9.98

**PM/819 2"**

Pos.	Description	Torque (nm)	Torque (ft - lb)
9	Nut M12	35	25
11	M12 balancing piston guide	35	25
25	Screw M16X70 UNI 5737	60	44
27	Screw M10X35 5739	45	33
29	Screw M6X14 UNI 5931	10	7
30	Screw M6X12 UNI 5931	10	7
31	Screw M12X35 UNI 5739	80	59

*Tab. 9.99*
**PM/819 3"**

Pos.	Description	Torque (nm)	Torque (ft - lb)
9	Nut M12	35	25
11	M12 balancing piston guide	35	25
25	Screw M18X90 UNI 5737	70	51
27	Screw M10X40 UNI 5737	45	33
29	Screw M6X14 UNI 5931	10	7
30	Screw M6X16 UNI 5931	10	7
31	Screw M12X40 UNI 5739	80	59
33	Nut M12 UNI 5589	35	25

*Tab. 9.100*
**PM/819 4"**

Pos.	Description	Torque (nm)	Torque (ft - lb)
9	Nut M12	35	25
11	M12 piston guide	35	25
25	Screw M18X90 UNI 5737	70	51
27	Screw M10X40 UNI 5737	45	33
29	Screw M6X14 UNI 5931	10	7
30	Screw M6X16 UNI 5931	10	7
31	Screw M16X50 UNI 5737	150	110
33	Nut M12 UNI 5589	35	25

*Tab. 9.101*

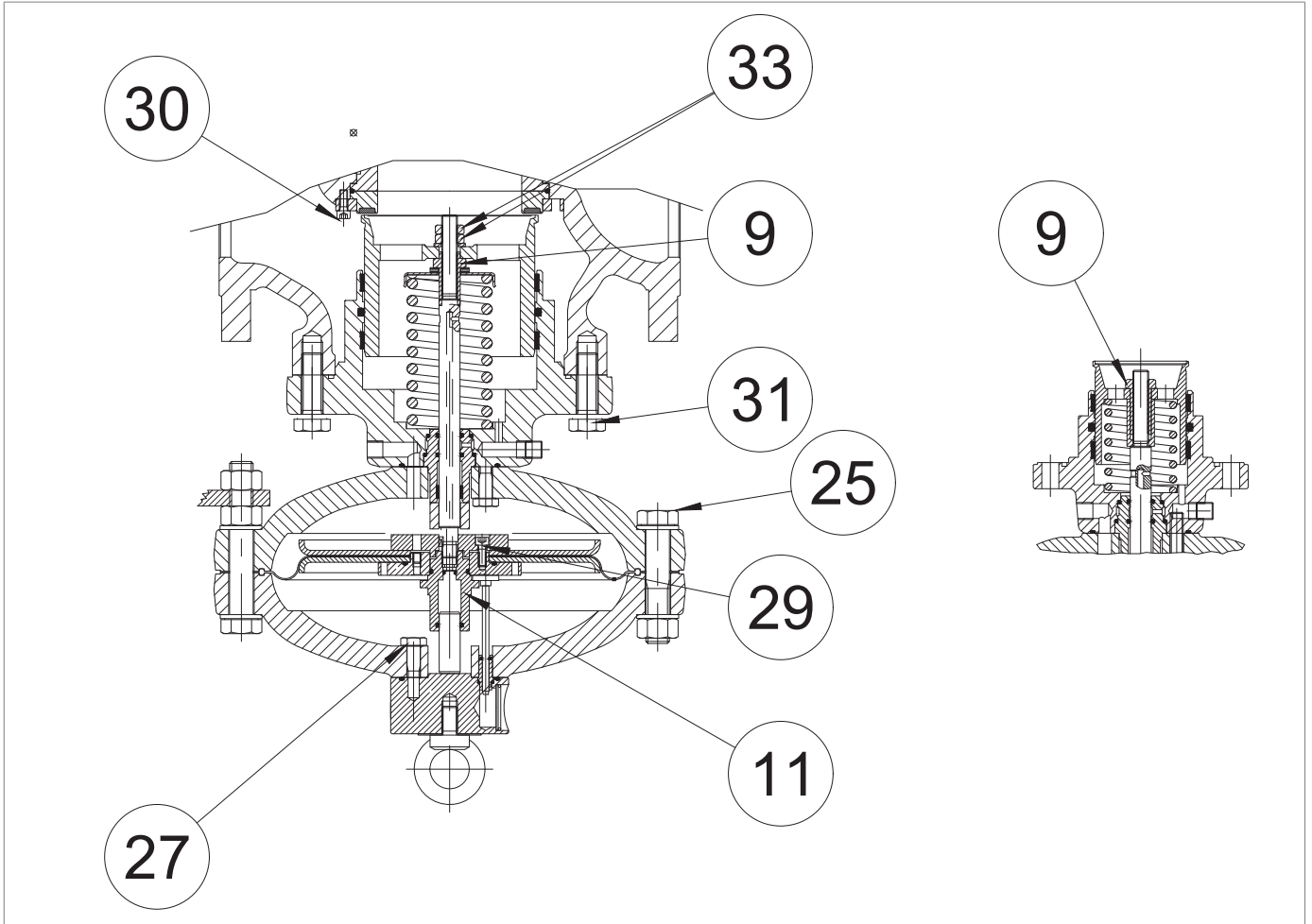

*Tightening torques for PM/819 built-in monitor*

**PM/819 6"**

Pos.	Description	Torque (nm)	Torque (ft - lb)
9	Nut M24	110	81
11	M18 balancing piston guide	110	81
25	Screw M22X120 UNI 5737	100	73
27	Screw M14X50 UNI 5737	115	84
29	Screw M6X16 UNI 5931	10	7
30	Screw M6X16 UNI 5931	10	7
31	Screw M20X60 UNI 5737	250	184
33	Nut M18 UNI 5589	110	81

*Tab. 9.102*
**PM/819 8"**

Pos.	Description	Torque (nm)	Torque (ft - lb)
9	Nut M24	110	81
11	M18 balancing piston guide	110	81
25	Screw M22X120 UNI 5737	100	73
27	Screw M14X50 UNI 5737	115	84
29	Screw M6X16 UNI 5931	10	7
30	Screw M6X16 UNI 5931	10	7
31	Screw M22X70 UNI 5737	280	206
33	Nut M18 UNI 5589	110	81

*Tab. 9.103*
**PM/819 10"**

Pos.	Description	Torque (nm)	Torque (ft - lb)
9	Nut M30	150	110
11	M18 balancing piston guide	150	110
25	Screw M27X150 UNI 5737	220	162
27	Screw M20X80 UNI 5737	250	184
29	Screw M6X16 UNI 5737	10	7
30	Screw M6X16 UNI 5931	10	7
31	Screw M22X70 UNI 5737	280	206
33	Nut M20 UNI 5589	150	110

*Tab. 9.104*

### 9.4.1.3 - PILOT TORQUES 200/A AND 200/A/FO SERIES

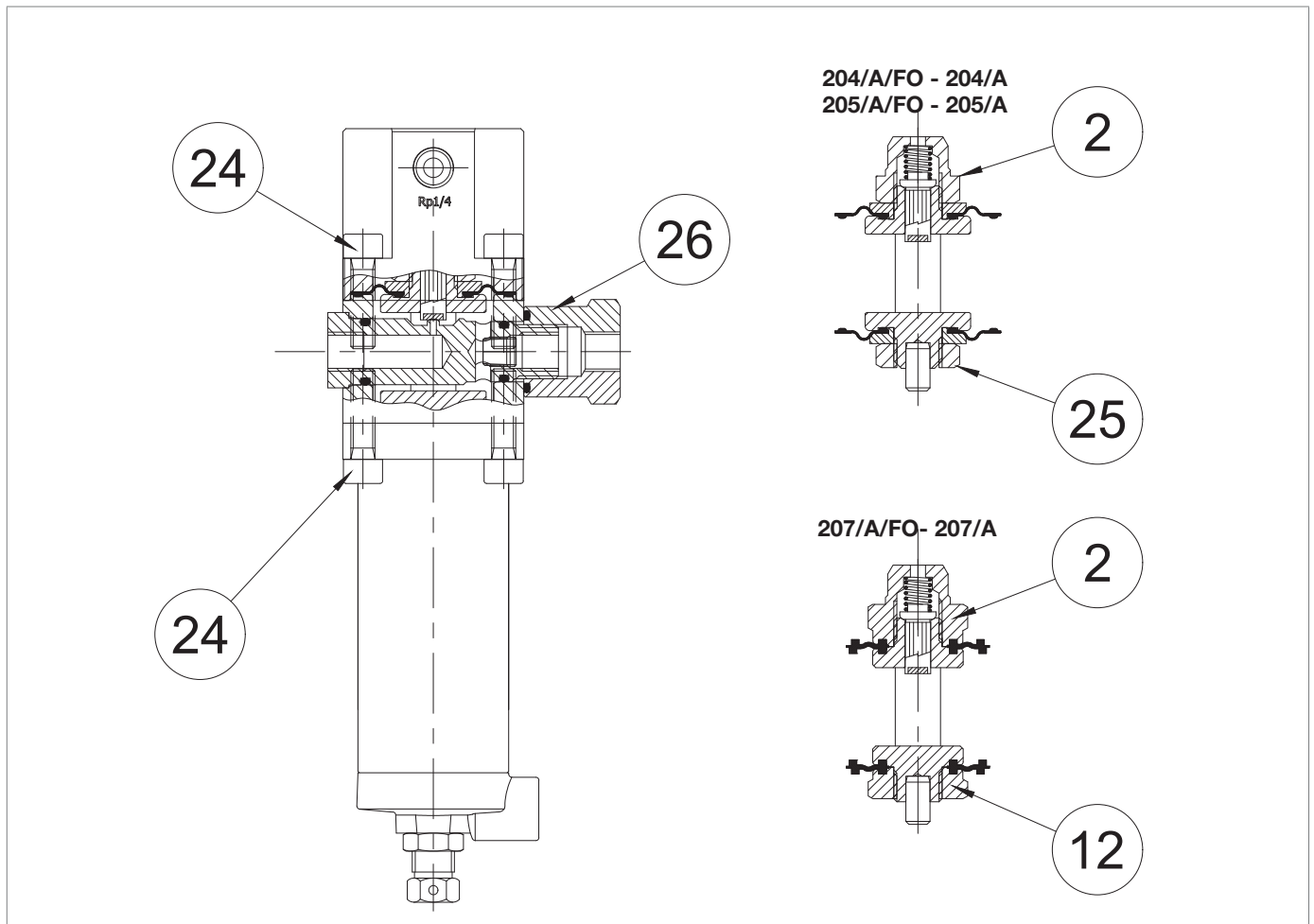

Fig. 9.42. Tightening torques 200/A and 200/A/FO series pilots

#### PILOTS 204/A/FO-204/A and 205/A/FO-205/A

Pos.	Description	Torque (Nm)	Torque (ft - lb)
2	Nut M16X1	25	18
24	Screw M8X30 UNI 5931	20	14
25	Nut M16X1.5	25	18
26	Nut M18X1.5	20	14

Tab. 9.105.

#### PILOT 207/A/FO and 207/A

Pos.	Description	Torque (Nm)	Torque (ft - lb)
2	Nut M16X1	25	18
12	Nut M16X1	25	18
24	Screw M8X30 UNI 5931 AISI	20	14
26	Nut M18X1.5	20	14

Tab. 9.106.

#### 9.4.1.4 - R14/A/FO AND R14/A PRE-REGULATOR TORQUES

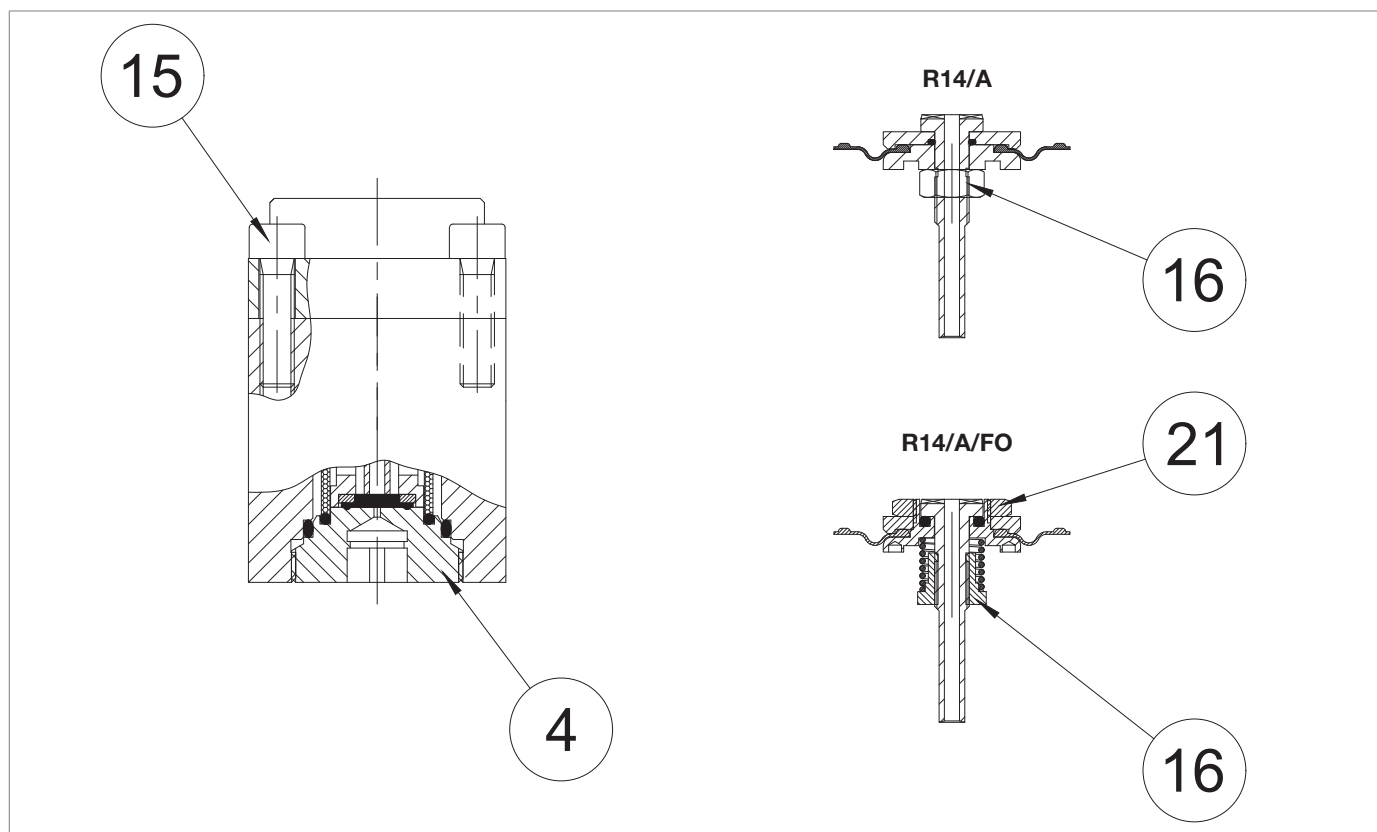

Fig. 9.43. R14/A/FO and R14/A pre-regulator tightening torques

R14/A/FO and R14/A PRE-REGULATOR			
Pos.	Description	Torque (Nm)	Torque (ft - lb)
4	Cap	35	25
15	Nut M8X30 UNI 5931	20	14
16	Nut M8 UNI 5588	8	5
21	Nut M18X1	8	5

Tab. 9.107.

**9.4.1.5 - TIGHTENING TORQUES FOR SB/82 BUILT-IN SLAM-SHUT VALVE**

Fig. 9.44. Tightening torques for SB/82 1" built-in slam-shut valve

SB/82 1"			
Pos.	Description	Torque (nm)	Torque (ft - lb)
5	Safety valve screw M10	40	29
11	Screw M6X12 UNI 5931	10	7
34	Screw M6X20 UNI 5931	10	7
35	Screw M6X20 UNI 5931	10	7
36	Screw M12X45 UNI 5931	80	59
37	Screw M10X25 UNI 5931	45	33
39	Screw M6X20 UNI 5931	10	7

Tab. 9.108

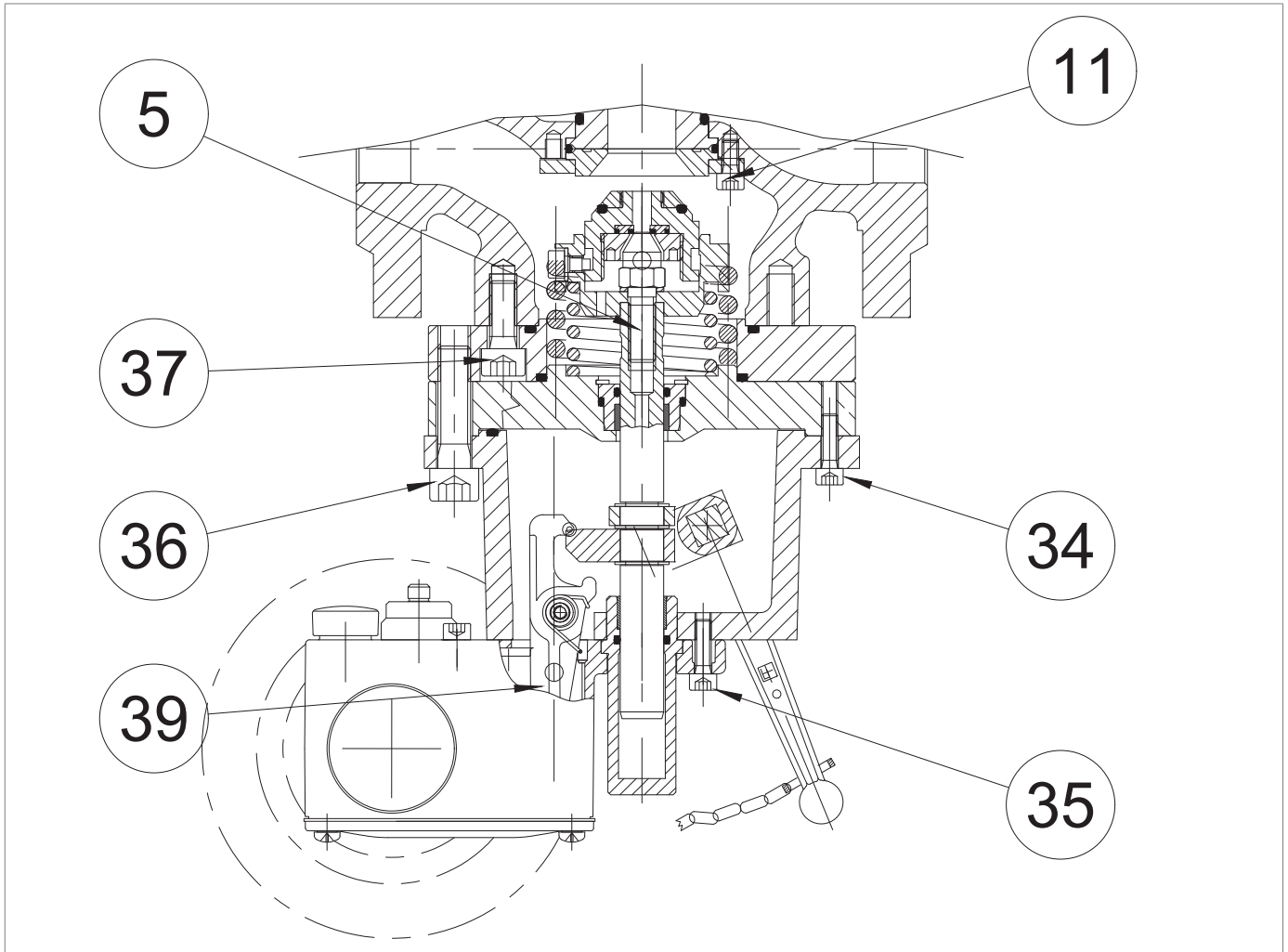
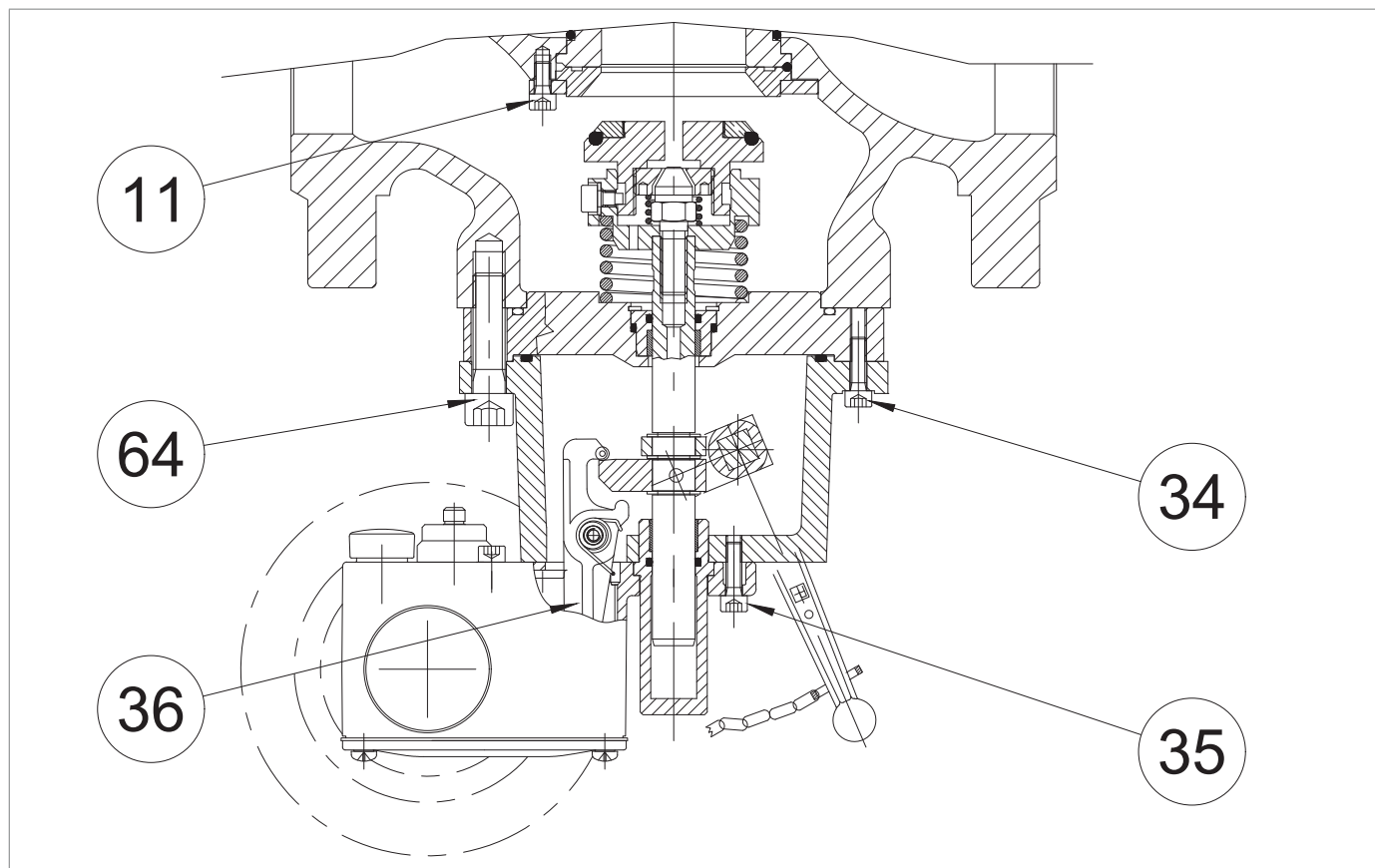

Fig. 9.45. Tightening torques for SB/82 2" built-in slam-shut valve

SB/82 2"			
Pos.	Description	Torque (nm)	Torque (ft - lb)
5	Safety valve screw M10	40	29
11	Screw M6X12 UNI 5931	10	5
34	Screw M6X20 UNI 5931	10	5
35	Screw M6X20 UNI 5931	10	5
36	Screw M6X20 UNI 5931	10	5
64	Screw M12X45 UNI 5931	80	59

Tab. 9.109

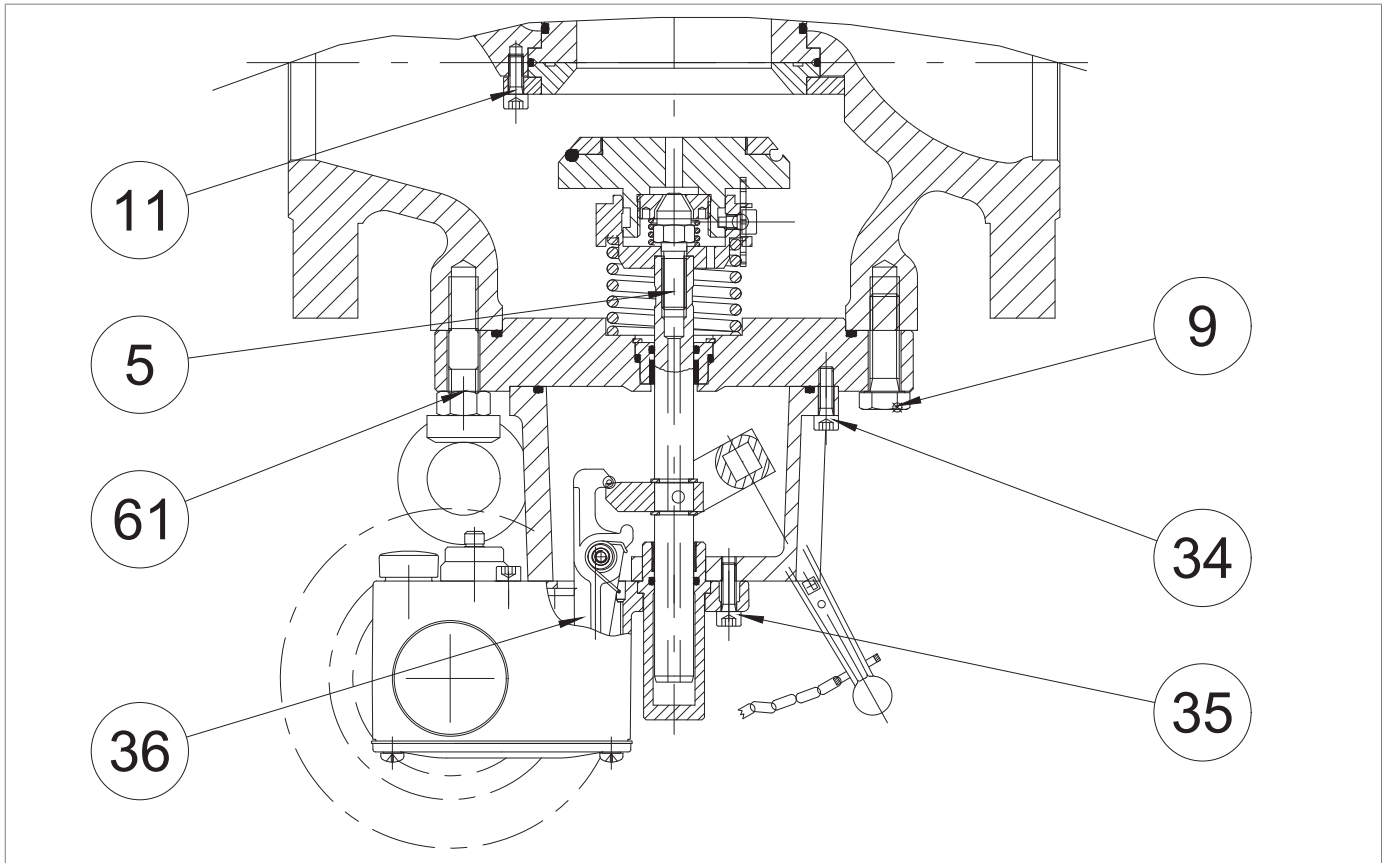

Fig. 9.46. Tightening torques for SB/82 3"-4" built-in slam-shut valve

SB/82 3"			
Pos.	Description	Torque (nm)	Torque (ft - lb)
5	Safety valve screw M10	40	29
9	Screw M12X40 UNI 5739	80	59
11	Screw M6X12 UNI 5931	10	5
34	Screw M6X20 UNI 5931	10	5
35	Screw M6X20 UNI 5931	10	5
36	Screw M6X20 UNI 5931	10	5
61	Nut M12 UNI 5588	80	59

Tab. 9.110

SB/82 4"			
Pos.	Description	Torque (nm)	Torque (ft - lb)
5	Safety valve screw M10	40	29
9	Screw M16X50 UNI 5737	150	110
11	Screw M6X16 UNI 5931	10	5
33	Screw M6X14 UNI 5934	10	5
34	Screw M6X20 UNI 5931	10	5
35	Screw M6X14 UNI 5933	10	5
36	Screw M6X20 UNI 5931	10	5

Tab. 9.111

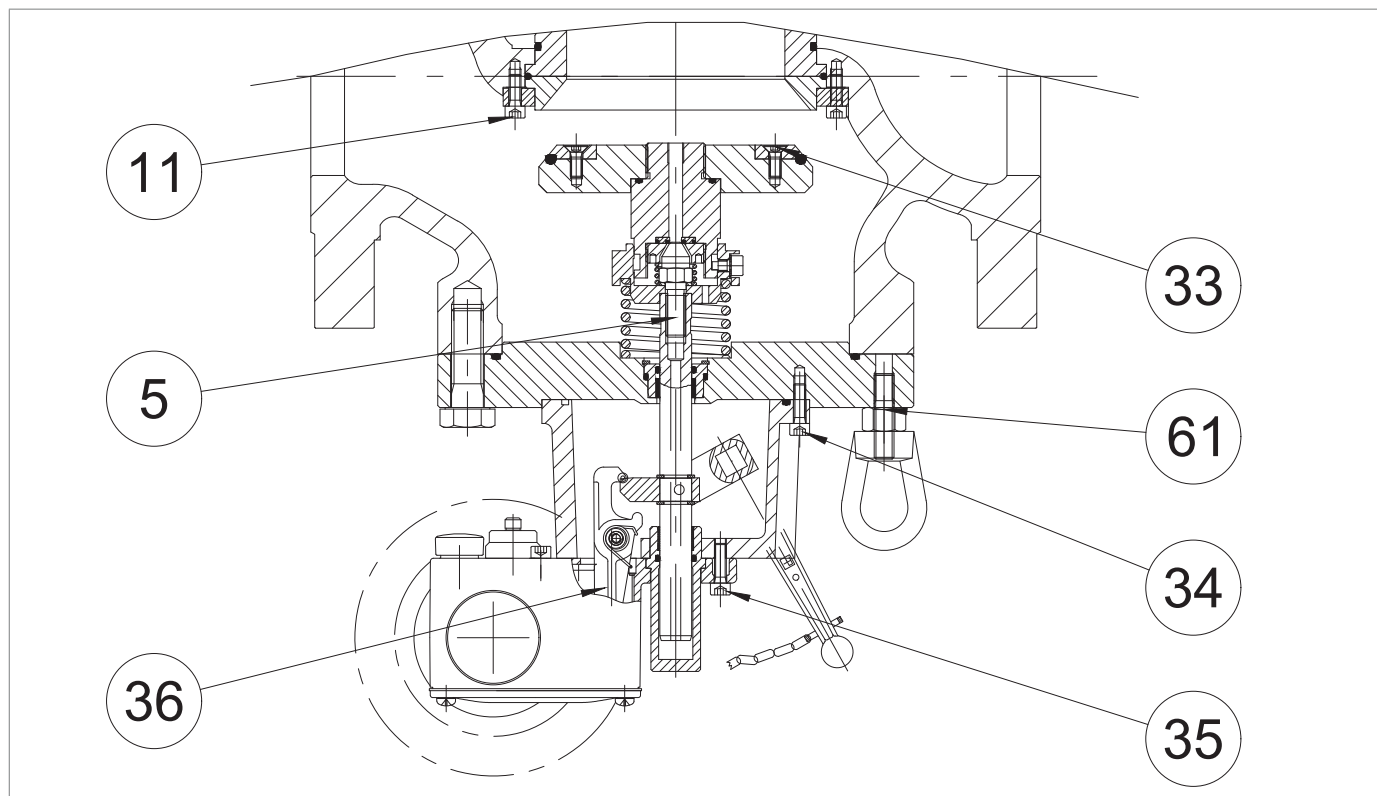

Fig. 9.47. Tightening torques for SB/82 6"-8" built-in slam-shut valve

SB/82 6"			
Pos.	Description	Torque (nm)	Torque (ft - lb)
5	Safety valve screw	40	29
10	Screw M14X50 UNI 5737	115	84
11	Screw M6X16 UNI 5931	10	5
33	Screw M6X10 UNI 5931	10	5
34	Screw M8X25 UNI 5931	20	14
35	Screw M6X40 UNI 5931	10	5
36	Screw M6X20 UNI 5931	10	5
61	Nut M14 UNI 5588	115	84

Tab. 9.112

SB/82 8"			
Pos.	Description	Torque (nm)	Torque (ft - lb)
5	Safety valve screw M10	40	29
10	Screw M14X50 UNI 5737	115	84
11	Screw M6X16 UNI 5931	10	5
33	Screw M6X10 UNI 5931	10	5
34	Screw M8X25 UNI 5931	20	14
35	Screw M6X40 UNI 5931	10	5
36	Screw M6X20 UNI 5931	10	5
61	Nut M14 UNI 5588	115	84

Tab. 9.113

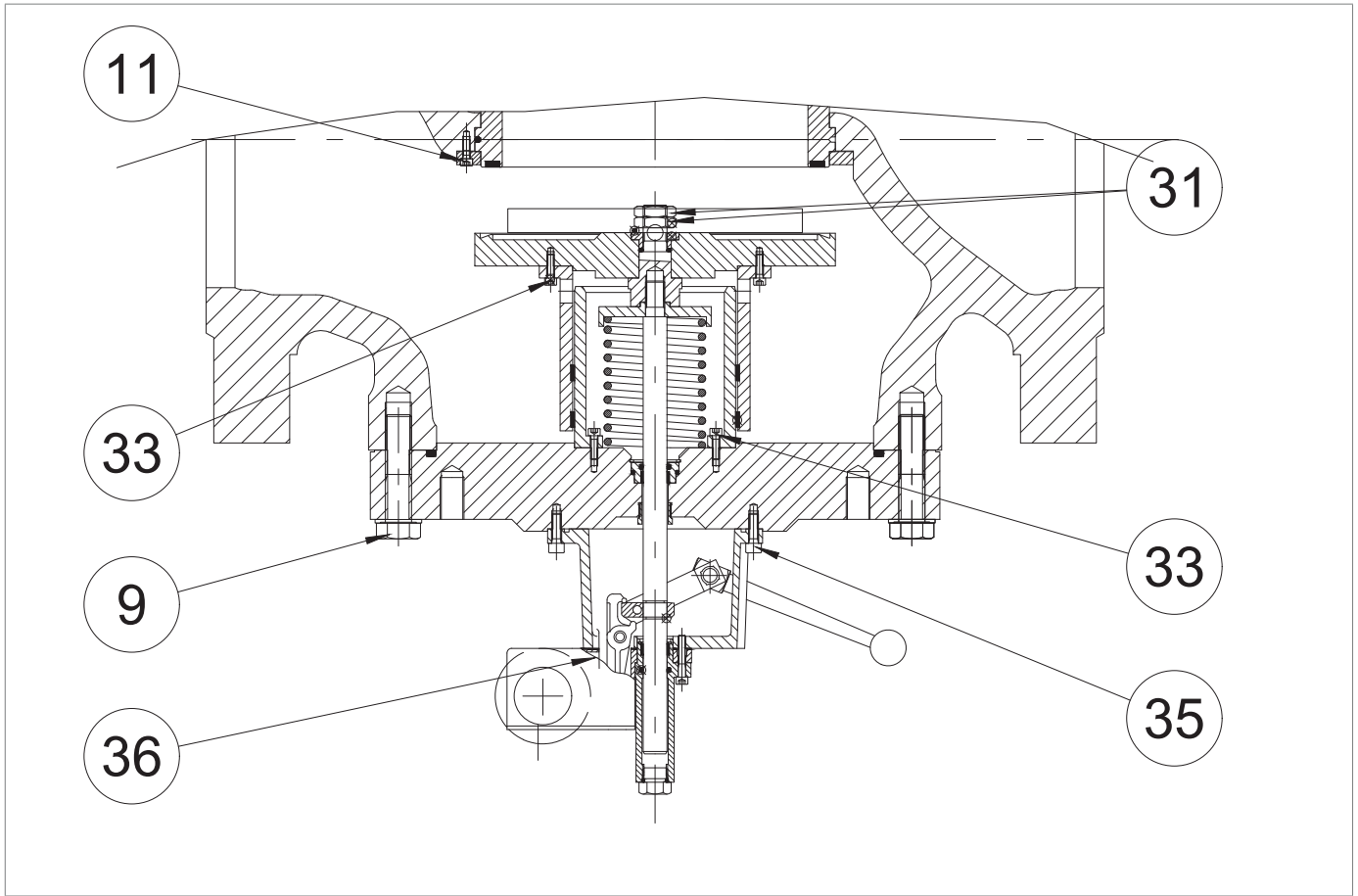

Fig. 9.48. Tightening torques for SB/82 10" built-in slam-shut valve

SB/82 10"			
Pos.	Description	Torque (nm)	Torque (ft - lb)
9	Screw M16X90 UNI 5737	150	110
11	Screw M6X16 UNI 5931	10	5
31	Nut M20 UNI 5589	250	184
33	Screw M6X20 UNI 5931	10	5
35	Screw M8X25 UNI 5931	20	14
36	Screw M6X35 UNI 5931	10	5
137	Screw M6X20 UNI 5931	10	5

Tab. 9.114

PAGE INTENTIONALLY LEFT BLANK

**9.4.1.6 - TIGHTENING TORQUES FOR PRESSURE SWITCHES MODELS 102M/102MH - 105M/105MH**

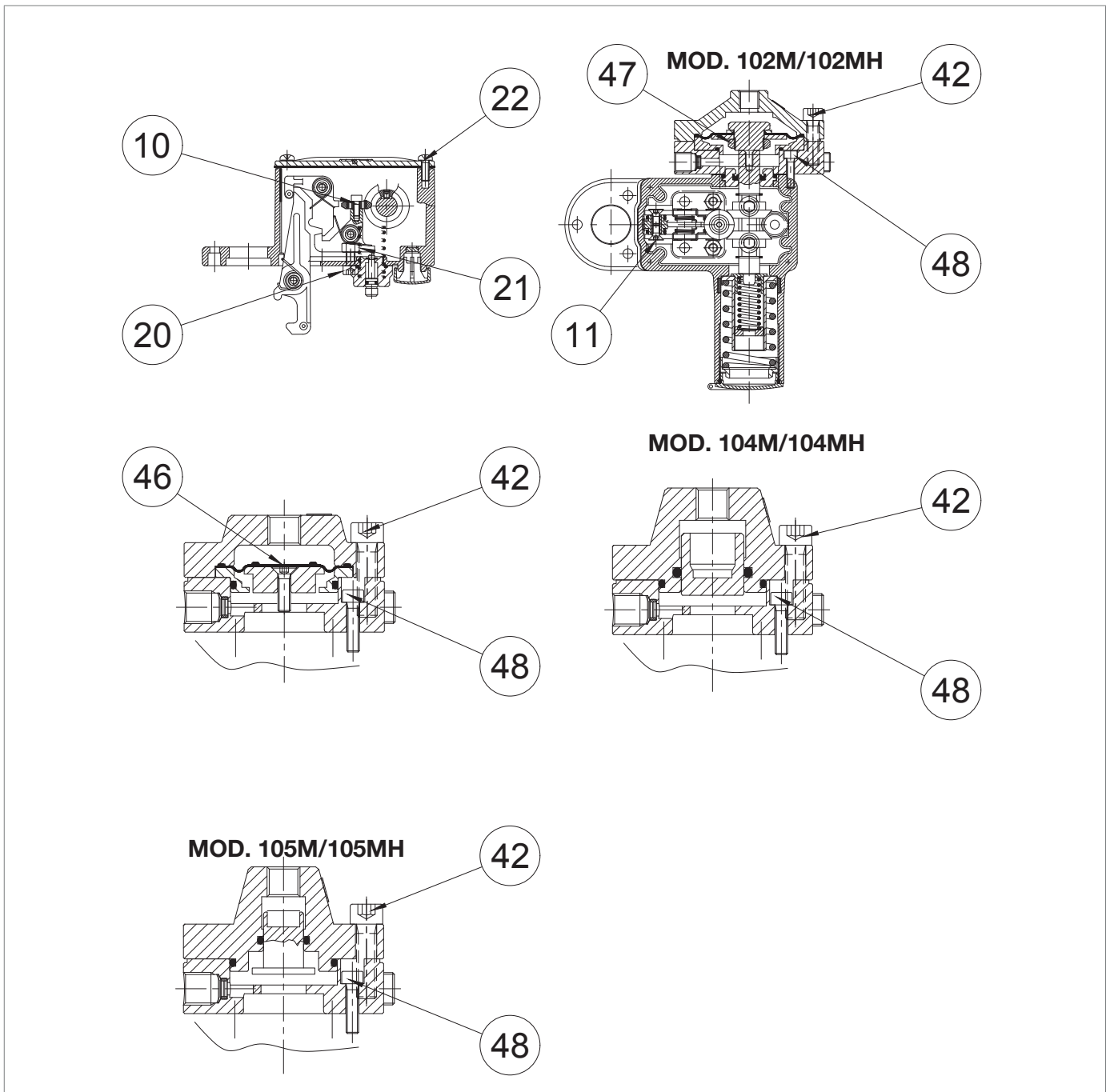

Fig. 9.49. Tightening torques for pressure switches models 102M/102MH - 105M/105MH

**MOD. 102M/102MH**

Pos.	Description	Torque (nm)	Torque (ft - lb)
10	Screw M4X10 UNI 5931	3	2.21
11	Screw M5X10 UNI 5933	5	3.68
20	Screw M6X16 UNI 5931	10	7.37
21	Nut M6 UNI 5588	10	7.37
22	Screw M5X15 UNI 8112	5	3.68
42	Screw M6X25 UNI 5931	16	11.80
47	Nut M20X1	8	5.90
48	Screw M5X16 UNI 5931	5	3.68

*Tab. 9.115*
**MOD. 103M/103MH**

Pos.	Description	Torque (nm)	Torque (ft - lb)
10	Screw M4X10 UNI 5931	3	2.21
11	Screw M5X10 UNI 5933	5	3.68
20	Screw M6X16 UNI 5931	10	7.37
21	Nut M6 UNI 5588	10	7.37
22	Screw M5X15 UNI 8112	5	3.68
42	Screw M8X30 UNI 5931	16	11.80
46	Screw M5X18 UNI 5931	8	5.90
48	Screw M5X20 UNI 5931	5	3.68

*Tab. 9.116*
**MOD. 104M/104MH - 105M/105MH**

Pos.	Description	Torque (nm)	Torque (ft - lb)
10	Screw M4X10 UNI 5931	3	2.21
11	Screw M5X10 UNI 5933	5	3.68
20	Screw M6X16 UNI 5931	10	7.37
21	Nut M6 UNI 5588	10	7.37
22	Screw M5X15 UNI 8112	5	3.68
42	Screw M8X30 UNI 5931	16	11.80
48	Screw M5X20 UNI 5931	5	3.68

*Tab. 9.117*

#### 9.4.1.7 - TIGHTENING TORQUES FOR HB/97 BUILT-IN SLAM-SHUT VALVE WITH LINE-OFF

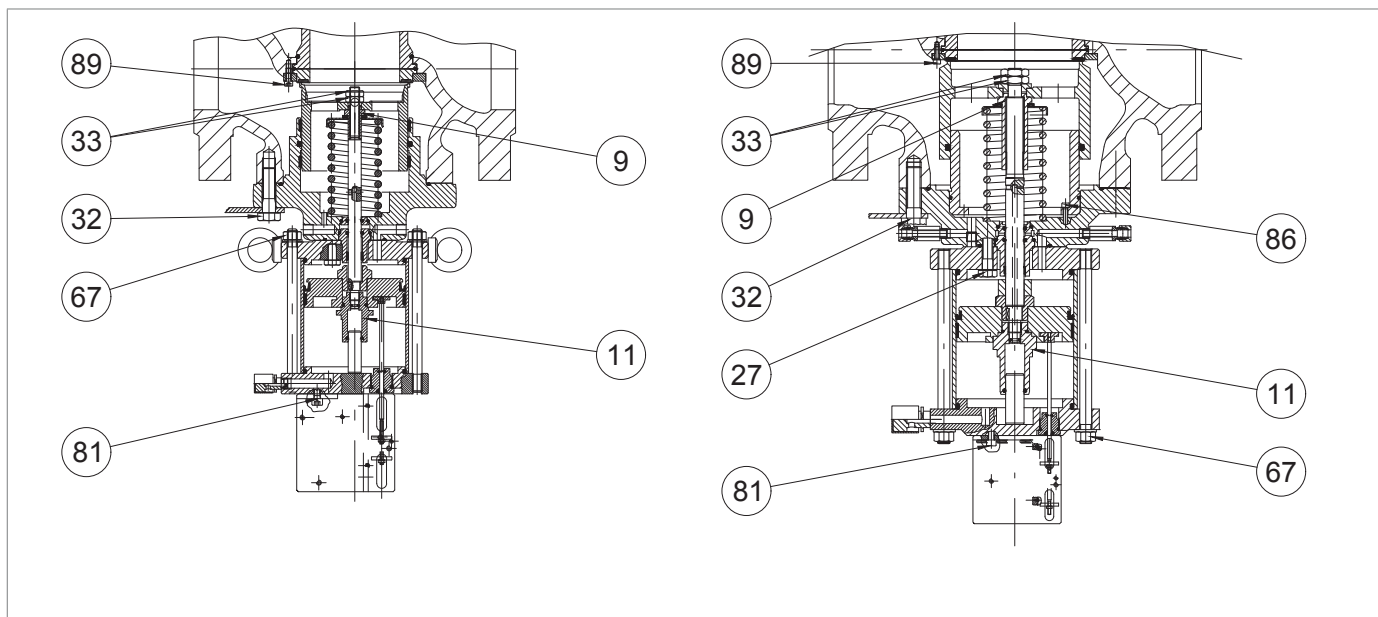

Fig. 9.50. Tightening torques for HB/97 built-in slam-shut valve with LINE OFF

HB/97 4"			
Pos.	Description	Torque (nm)	Torque (ft - lb)
9	Locking nut M12X1.25	35	25
11	M12X1.25 balancing piston guide	35	25
27	Screw M10X40 UNI 5737	45	33
33	Nut M12X1.25 UNI 5589	35	25
67	Nut M12 UNI 5588	80	59
81	Screw M8X16 UNI 5931	20	14
87	Screw M6X16 UNI 5931	10	7

Tab. 9.118

HB/97 6"			
Pos.	Description	Torque (nm)	Torque (ft - lb)
9	Locking nut M24X1.5	110	81
11	M18X1.5 balancing piston guide	110	81
27	Screw M14X50 UNI 5737	115	84
33	Nut M18X1.5 UNI 5589	110	81
67	Nut M16 UNI 5588	200	147
81	Screw M8X20 UNI 5931	20	14
86	Screw M6X25 UNI 5931	10	7
89	Screw M6X16 UNI 5931	10	7

Tab. 9.119

**HB/97 8"**

Pos.	Description	Torque (nm)	Torque (ft - lb)
9	Locking nut M24X1.5	110	81
11	M18X1.5 balancing piston guide	110	81
27	Screw M14X50 UNI 5737	115	84
33	Nut M18X1.5 UNI 5589	110	81
67	Nut M16 UNI 5588	200	147
81	Screw M8X20 UNI 5931	20	14
86	Screw M6X25 UNI 5931	10	7
89	Screw M6X16 UNI 5931	10	7

*Tab. 9.120*
**HB/97 10"**

Pos.	Description	Torque (nm)	Torque (ft - lb)
9	Locking nut M30X1.5	150	110
11	M22X1.5 balancing piston guide	150	110
27	Screw M20X70 UNI 5931	250	184
33	Nut M20X1.5 UNI 5589	150	110
67	Nut M16 UNI 5588	200	147
81	Screw M8X20 UNI 5931	20	14
86	Screw M6X25 UNI 5931	10	7
89	Screw M6X16 UNI 5931	10	7

*Tab. 9.121*
**HB/97 12"**

Pos.	Description	Torque (nm)	Torque (ft - lb)
9	Locking nut M30X1.5	150	110
11	M22X1.5 balancing piston guide	150	110
27	Screw M20X70 UNI 5931	250	184
33	Nut M20X1.5 UNI 5589	150	110
67	Nut M16 UNI 5588	200	147
81	Screw M8X20 UNI 5931	20	14
86	Screw M6X25 UNI 5931	10	7
89	Screw M6X16 UNI 5931	10	7

*Tab. 9.122*

**9.4.1.8 - TIGHTENING TORQUES FOR HP2/2 BYPASS DEVICE**

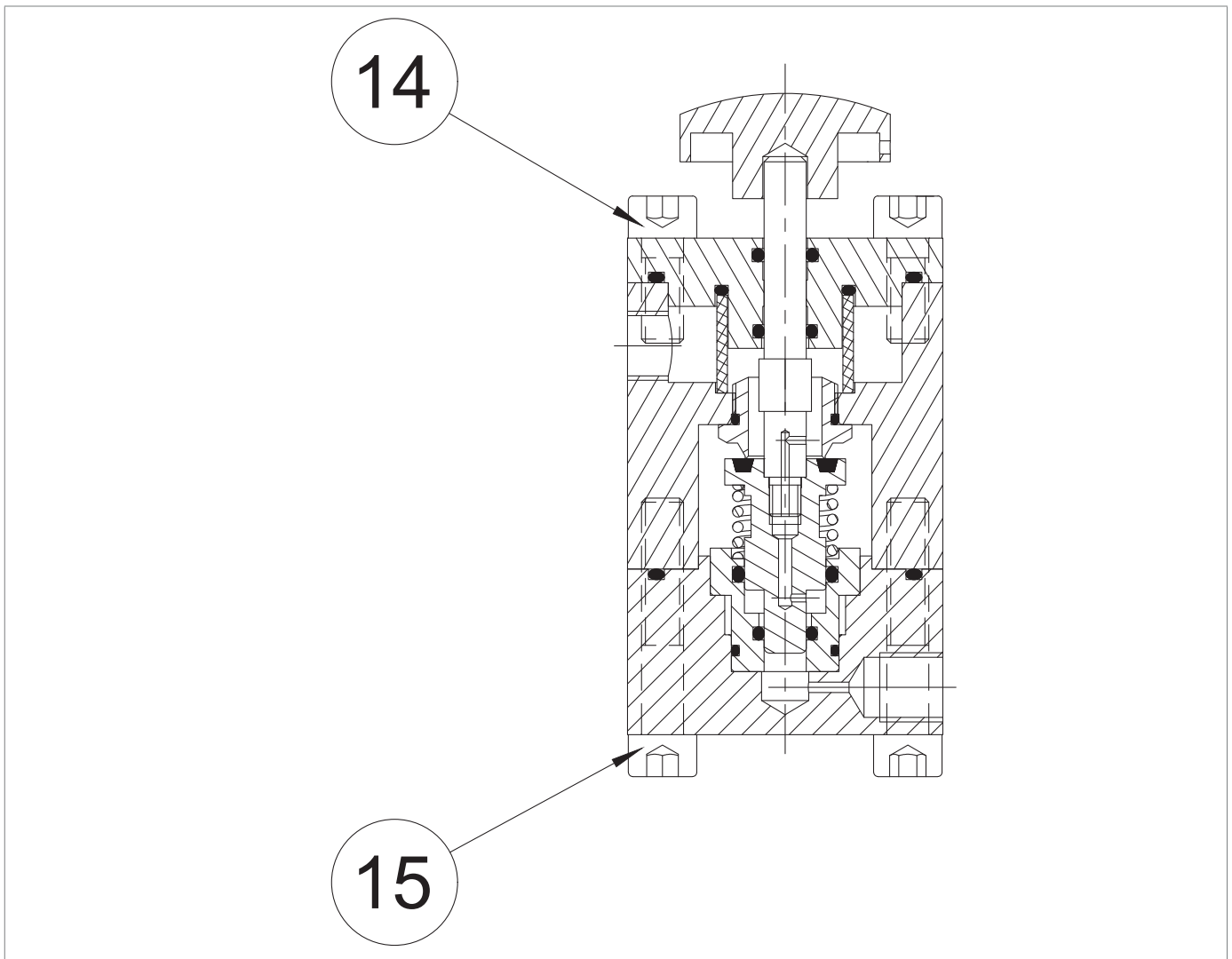

Fig. 9.51. Tightening torques for HP2/2 bypass device

HP/22			
Pos.	Description	Torque (nm)	Torque (ft - lb)
14	Screw M8X20 UNI 5931	16	11
15	Screw M8X45 UNI 5931	16	11

Tab. 9.123

### 9.4.1.9 - TIGHTENING TORQUES FOR THROTTLE VALVE AR100

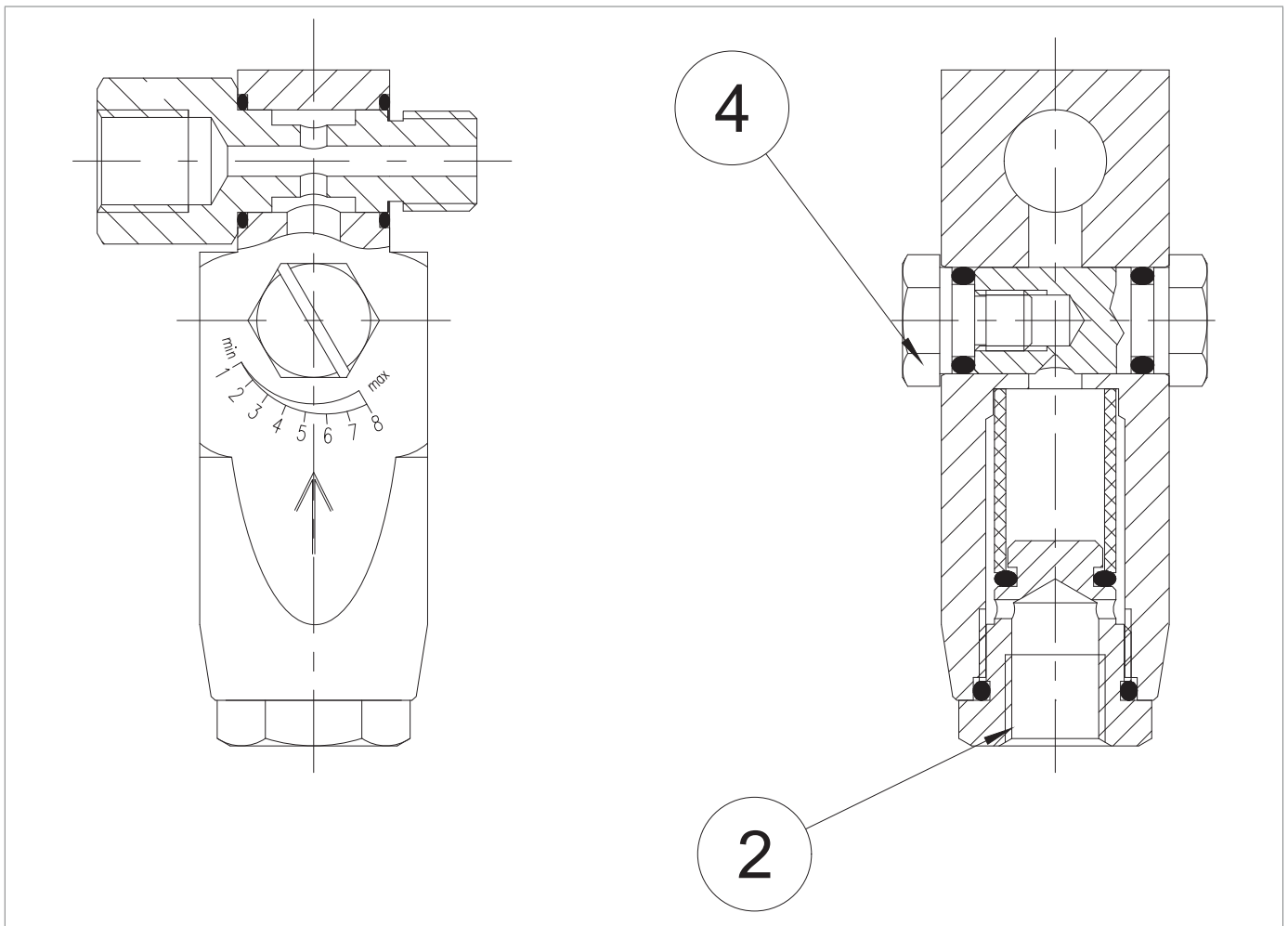

Fig. 9.52. Tightening torques for throttle valve AR100

LAMINATION VALVE AR100			
Pos.	Description	Torque (nm)	Torque (ft - lb)
2	Cap M20X1.5	20	14
4	Screw M8 AISI	4	2

Tab. 9.124

**9.4.1.10 - TIGHTENING TORQUES FOR R44/SS REGULATOR**

Fig. 9.53. Tightening torques for R44/SS regulator

R44/SS			
Pos.	Description	Torque (nm)	Torque (ft - lb)
2	Nut M16X1	25	18
24	Screw M8X110 UNI 5931	16	11
24.1	Screw M8X70 UNI 5931	16	11
25	Nut M16X1.5	25	18
26	Nut M18X1.5	20	14

Tab. 9.125

## 9.4.2 - REPLACING ELEMENTS SUBJECT TO WEAR AND ABRASION

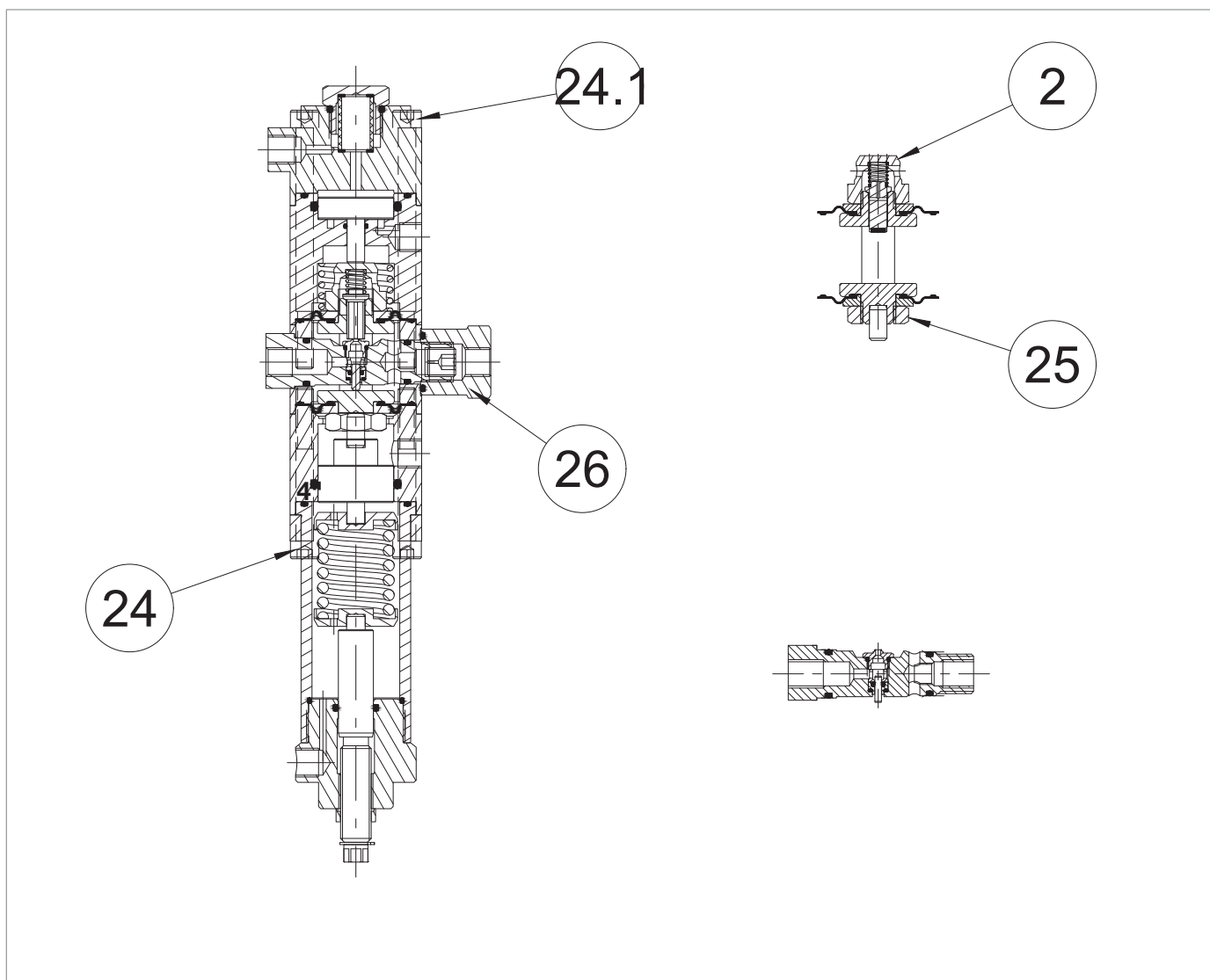
### 9.4.2.1 - INITIAL OPERATIONS

#### WARNING!

Before any intervention, it is necessary:

- to ensure that the line on which the equipment is installed is shut off upstream and downstream;
  - to operate the slam shut valve in manual mode by pressing the release button (Pos. 10 - Figure 4.13.).
- Next, check that the pressure indicated by the pressure gauge installed on the LINE OFF 2.0 device (Pos. 9.3 - Figure 8.36.) is 0 bar, ensuring complete depressurisation of the line.

#### ATTENTION!

During assembly, make sure to tighten the screws as per the tables (tightening torques), according to the size for which maintenance is being carried out.

Proceed as follows:

Step	Action
1	Unscrew the conical seal fittings to disconnect all power outlets and sensing lines for the pilot and regulator.
2	Loosen the nut securing the pilot support bracket to the regulator.
3	Remove the 200/A/FO series pilot present with the R14/A/FO pre-regulator from the regulator.
	<div style="border: 1px solid black; padding: 5px;">  <b>NOTICE!</b>            For replacement and pilot disconnection procedures for the 200/A/FO series and the R14/A/FO pre-regulator, please refer to section 9.4.6.         </div>

Tab. 9.126

### 9.4.2.2 - CROSS DIAGRAM FOR TIGHTENING SCREWS

When indicated by the maintenance procedure, refer to the following diagram to tighten the screws:

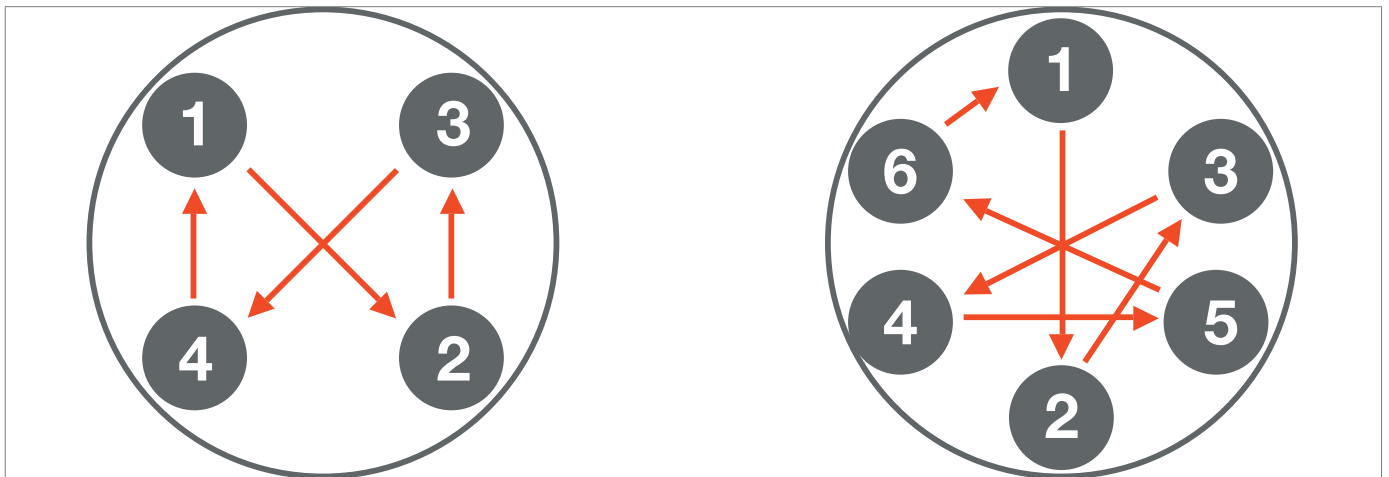

Fig. 9.54. Cross diagram

**9.4.3 - REGULATOR MAINTENANCE PROCEDURE REFLUX 819/FO**

**9.4.3.1 - REGULATOR REFLUX 819/FO 1"**

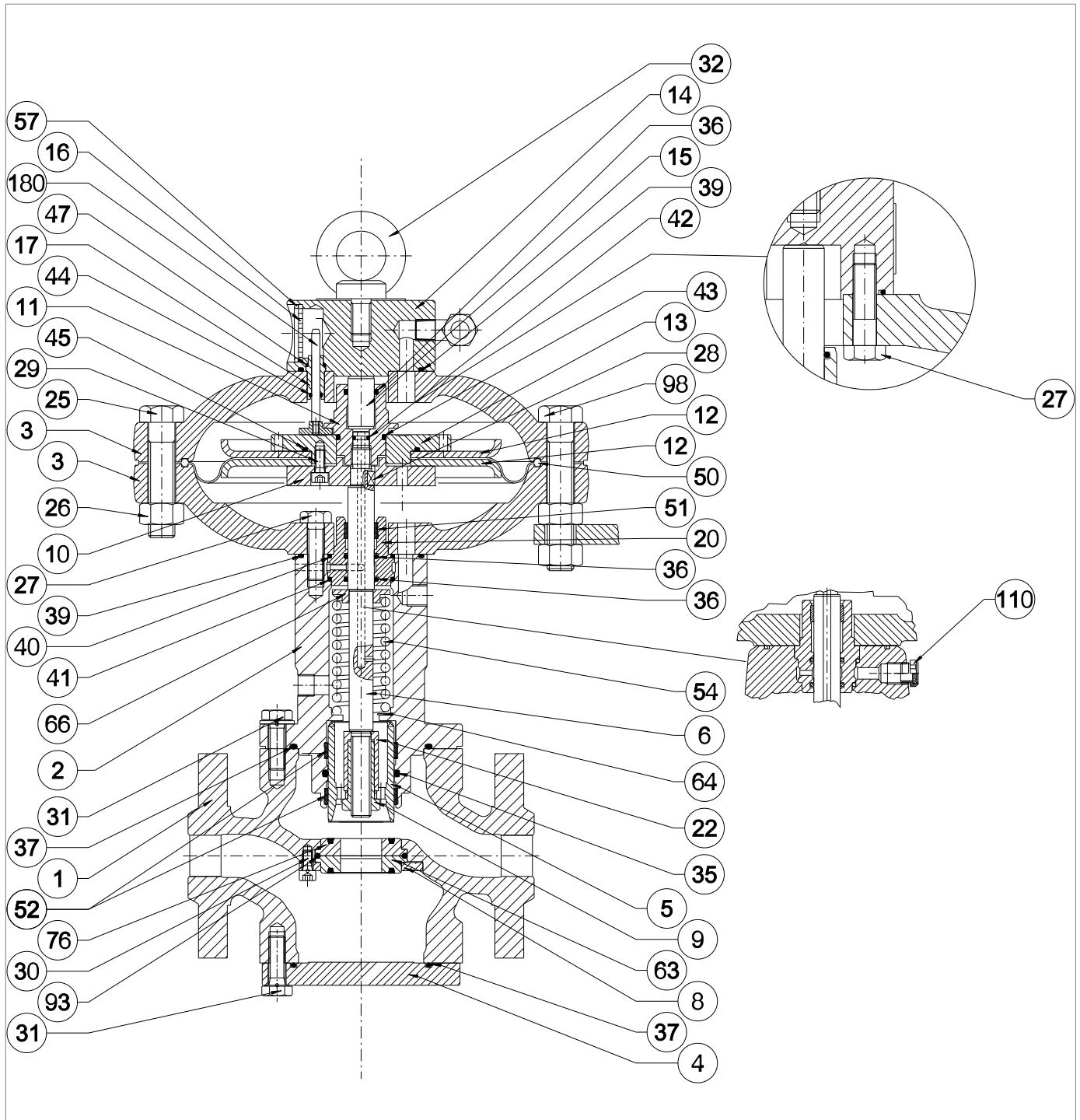
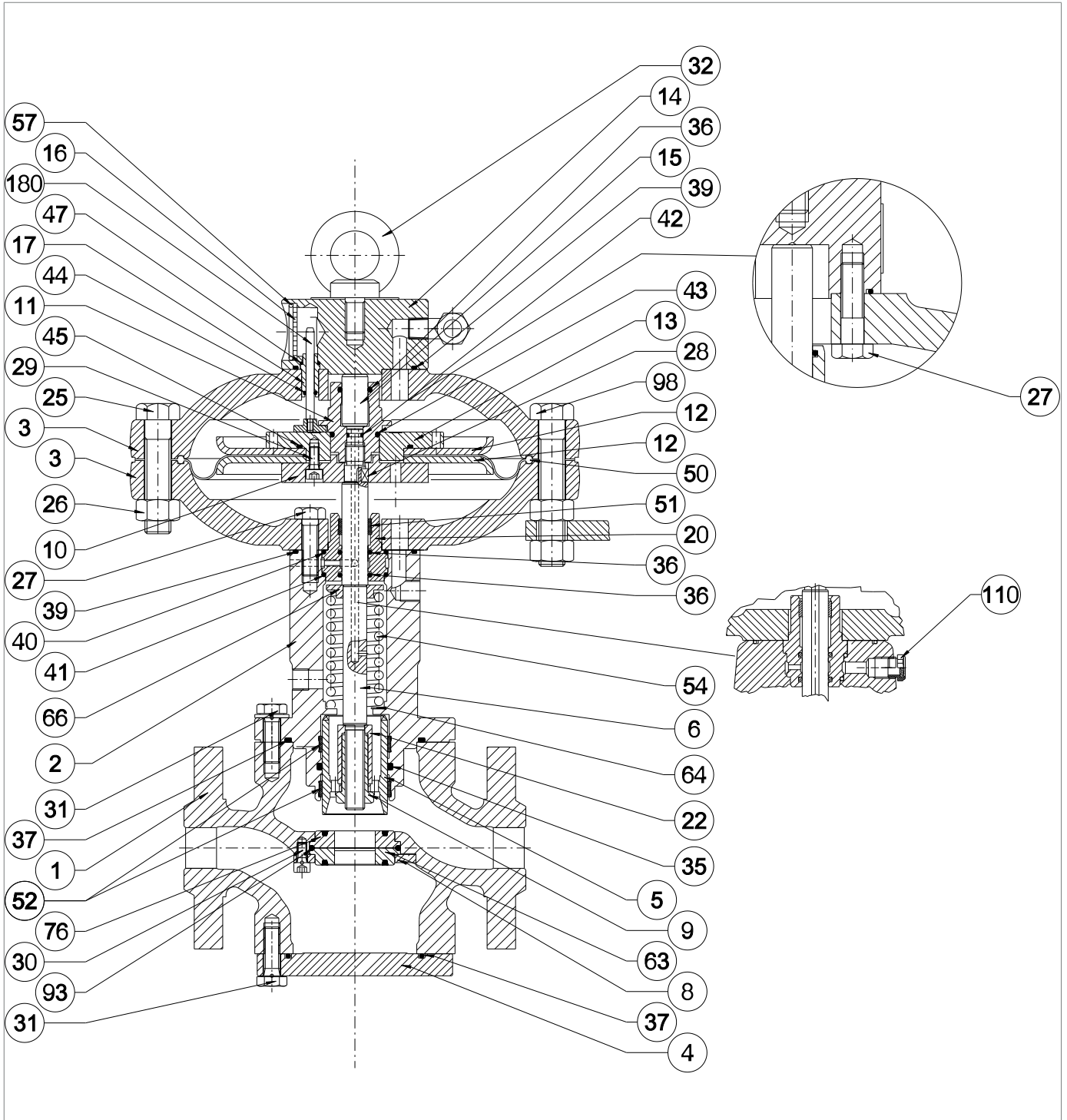

Fig. 9.55. Regulator REFLUX 819/FO 1"

Step	Action
1	<p>Unscrew and remove the upper screws (31) that secure the control head to the regulator body (1).</p> <p><b>! NOTICE!</b></p> <p><b>Support the head assembly during this step to avoid falls.</b></p>
2	<p>Remove the control head and place it on its side on a plane with an impact-resistant surface.</p> <p><b>! NOTICE!</b></p> <p><b>Take care not to damage the plug profile (5).</b></p>
3	<p>Remove the O-ring (37) from the plug guide (2) and replace it, lubricating it with synthetic grease.</p> <p><b>! NOTICE!</b></p> <p><b>Before inserting the replacement O-ring, clean the retaining slots with a cleaning solution.</b></p>
4	<p>Unscrew the lock nut (9).</p> <p><b>! NOTICE!</b></p> <p><b>Take care not to damage the plug profile (5).</b></p>
5	<p>Remove the plug (5) from the plug guide (2) and place it on a table with an impact-resistant surface.</p> <p><b>! NOTICE!</b></p> <p><b>Take care not to damage the plug profile (5).</b></p>
6	<p>Remove the O-ring (35) from the plug guide (2) and replace it, lubricating it with synthetic grease.</p> <p><b>! NOTICE!</b></p> <p><b>Before inserting the replacement O-ring, clean the retaining slots with a cleaning solution.</b></p>
7	<p>Remove the I/DWR rings (52) from the plug guide (2) and replace it, taking care to lubricate it with synthetic grease.</p> <p><b>! NOTICE!</b></p> <p><b>Before inserting the replacement I/DWR rings, clean the retaining slots with a cleaning solution.</b></p>
8	<p>Remove the spacer (22).</p>
9	<p>Unscrew and remove the screws (25, 98) together with the nuts (26).</p> <p><b>! NOTICE!</b></p> <p><b>During this phase, the spring (54) pushes the stem (6) upwards.</b></p>
10	<p>Remove the upper cover (3) together with the eyebolt flange (14).</p>
11	<p>Remove the indicator rod (180).</p>
12	<p>Undo and remove the upper screws (27).</p>
13	<p>Remove the eyebolt flange (14).</p>
14	<p>Remove the O-rings (39, 47) from the eyebolt flange (14) and replace them, lubricating them with synthetic grease.</p> <p><b>! NOTICE!</b></p> <p><b>Before inserting the replacement O-rings, clean the retaining slots with a cleaning solution.</b></p>
15	<p>Remove the rod guide (17) from the upper cover (3).</p>



Regulator REFLUX 819/FO 1"

REFLUX 819/FO

Step	Action
16	Remove the O-ring (44) from the rod guide (17) and replace it, lubricating it with synthetic grease. <b>NOTICE!</b> <b>Before inserting the replacement O-ring, clean the retaining slots with a cleaning solution.</b>
17	Place the rod guide (17) in the upper cover (3).
18	Position the eyebolt flange (14) on the upper cover (3).
19	Insert and fix the upper screws (27) according to the following tightening torque: • 1": Tab. 9.82 <b>NOTICE!</b> <b>Tighten the screws according to the cross diagram in paragraph 9.4.2.2.</b>
20	Insert the indicator rod (180) into the rod guide (17).
21	Unscrew and remove the balancing piston guide (11). <b>NOTICE!</b> <b>In this step, keep the diaphragm unit still, fitting the compass wrench into the holes in the upper diaphragm support (13).</b>
22	Remove the balancing piston (15) from the balancing piston guide (11). <b>NOTICE!</b> <b>Take care not to damage the surface of the balancing plunger (15).</b>
23	Remove the O-rings (36, 43) from the balancing piston guide (11) and replace them, taking care to lubricate them with synthetic grease. <b>NOTICE!</b> <b>Before inserting the replacement O-rings, clean the retaining slots with a cleaning solution.</b>
24	Insert the balancing piston (15) on the balancing piston guide (11). <b>NOTICE!</b> <b>Before inserting the balancing piston (15), clean and grease the surface with silicone grease.</b>
25	Remove the diaphragm assembly (13, 12, 45, 29, 10, 50). <b>NOTICE!</b> <b>Take care not to lose the key (28).</b>
26	Undo and remove the screws (29).
27	Remove the lower diaphragm support (10).
28	Remove the lower diaphragm protection disc (12).
29	Remove the diaphragm (50).
30	Remove the upper diaphragm protection disc (12).
31	Replace the O-ring (45) from the upper diaphragm support (13), lubricating it with synthetic grease. <b>NOTICE!</b> <b>Before inserting the replacement O-ring, clean the retaining slots with a cleaning solution.</b>

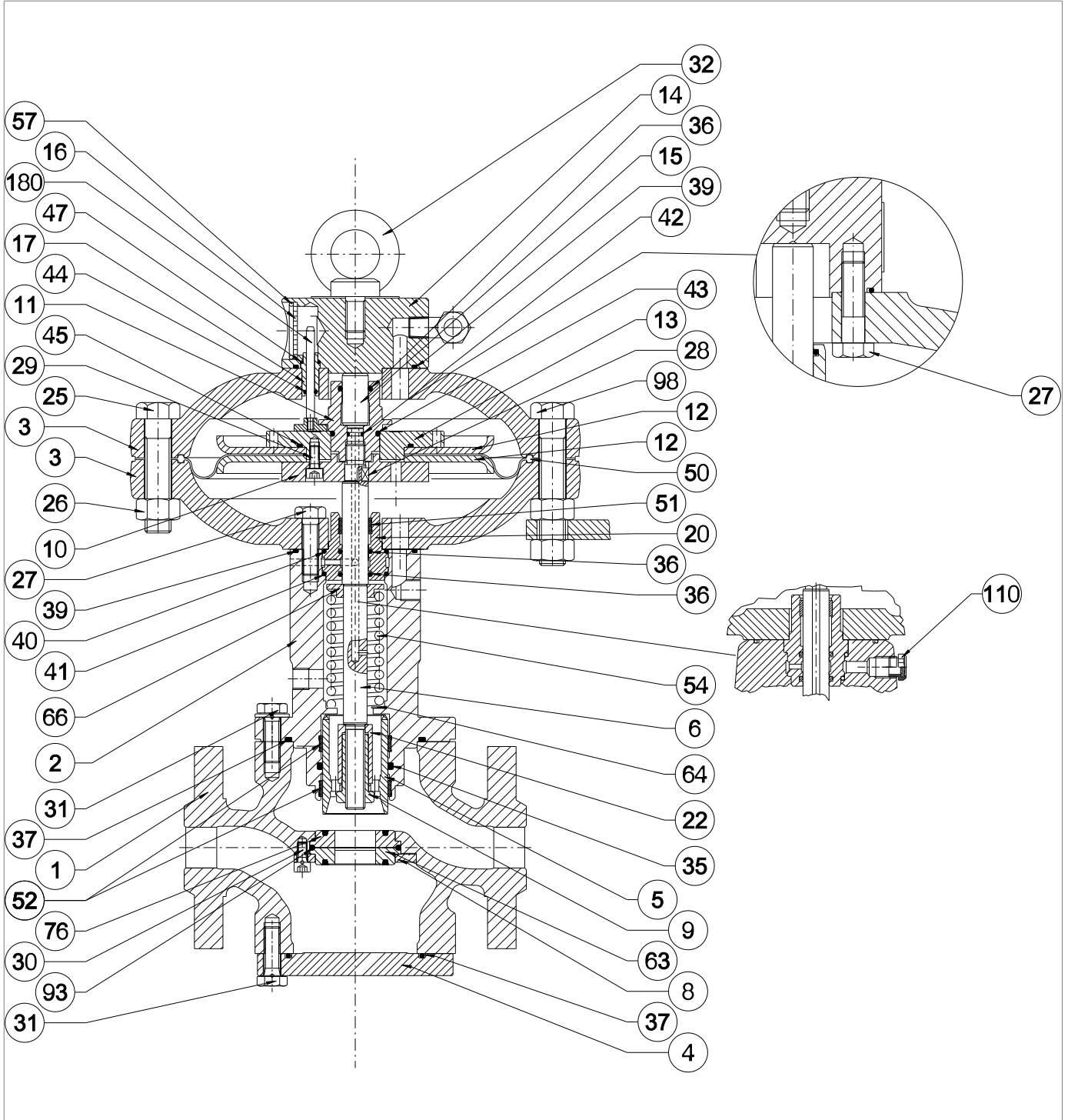

Regulator REFLUX 819/FO 1"

REFLUX 819/FO

Step	Action
32	Position the upper diaphragm protection disc (12).
33	Position the replacement diaphragm (50). <b>NOTICE!</b> <b>The concave part of the diaphragm must face the closing pressure chamber (pos. B, fig. 4.2).</b>
34	Position the lower diaphragm protection disc (12).
35	Position the lower diaphragm support (10).
36	Apply thread locking glue to insert and fix the screws (29) according to the following tightening torque: • 1": Tab. 9.82 <b>NOTICE!</b> <b>Tighten the screws according to the cross diagram in paragraph 9.4.2.2.</b>
37	Undo and remove the lower screws (27). <b>NOTICE!</b> <b>During this phase, the spring (54) pushes the stem (6) upwards.</b>
38	Remove the lower cover (3).
39	Remove the O-ring (39) from the plug guide (2) and replace it, lubricating it with synthetic grease. <b>NOTICE!</b> <b>Before inserting the replacement O-ring, clean the retaining slots with a cleaning solution.</b>
40	Remove the stem (6). <b>NOTICE!</b> <b>Take care not to damage the surface of the stem (6).</b>
41	Remove the O-ring (42) from the stem (6) and replace it, lubricating it with synthetic grease. <b>NOTICE!</b> <b>Before inserting the replacement O-ring, clean the retaining slots with a cleaning solution.</b>
42	Remove the stem guide (20) from the plug guide (2).
43	Remove and replace the O-ring (36) from the stem guide (20), lubricating it with silicone grease. <b>NOTICE!</b> <b>Before inserting the replacement O-ring, clean the retaining slots with a cleaning solution.</b>
44	Remove the O-rings (40, 41) from the stem guide (20) and replace them, lubricating them with synthetic grease. <b>NOTICE!</b> <b>Before inserting the replacement O-rings, clean the retaining slots with a cleaning solution.</b>
45	Remove the I/DWR ring (51) from the stem guide (20) and replace it, lubricating it with synthetic grease. <b>NOTICE!</b> <b>Before inserting the replacement I/DWR ring, clean the retaining slots with a cleaning solution.</b>

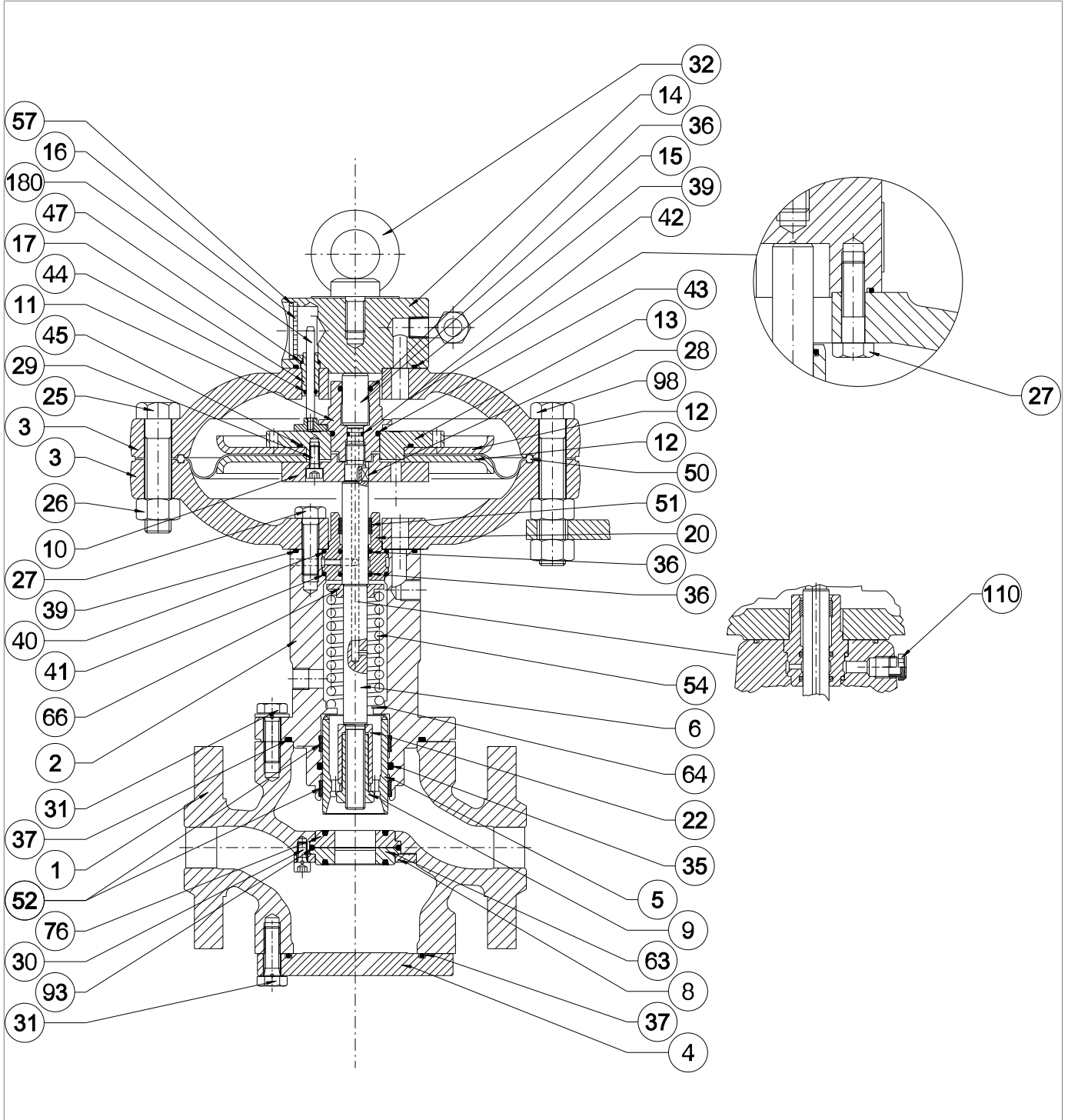

Regulator REFLUX 819/FO 1"

REFLUX 819/FO

Step	Action
46	<p>Insert the stem (6) into the stem guide (20).</p> <p><b>NOTICE!</b> Before inserting the stem (6), clean and lubricate the surface with silicone grease.</p>
47	Position the stem guide (20), stem (6) in the plug guide (2).
48	<p>Place the lower cover (3) on the plug guide (2).</p> <p><b>NOTICE!</b> The hole for the passage of the loading pressure must match the similar one on the plug guide.</p>
49	<p>Insert and fasten the lower screws (27) according to the tightening torque:</p> <ul style="list-style-type: none"> <li>• 1": Tab. 9.82</li> </ul> <p><b>NOTICE!</b> Tighten the screws according to the cross diagram in paragraph 9.4.2.2.</p>
50	<p>Fit the diaphragm assembly (13, 12, 45, 29, 10, 50).</p> <p><b>NOTICE!</b> Take care not to lose the key (28).</p>
51	<p>Insert and secure the balancing piston guide (11) according to the tightening torque:</p> <ul style="list-style-type: none"> <li>• 1": Tab. 9.82</li> </ul> <p><b>NOTICE!</b> Hold the diaphragm assembly in place by positioning the spanner in the holes in the upper diaphragm support (13).</p>
52	Position the upper cover (3) together with the eyebolt flange (14).
53	<p>Insert and fasten screws (25, 98) together with nuts (26).</p> <ul style="list-style-type: none"> <li>• 1": Tab. 9.82</li> </ul> <p><b>NOTICE!</b> Tighten the screws according to the cross diagram in paragraph 9.4.2.2.</p>
54	<p>Insert the spacer (22).</p> <p><b>NOTICE!</b> Fit the spacer (22) so that the stop with the narrower hole rests on the surface of the stem (6).</p>
55	<p>Insert the plug (5) into the plug guide (2).</p> <p><b>NOTICE!</b> Before inserting the plug (2), clean and lubricate the surface with silicone grease.</p>
56	<p>Insert and secure the locking nut (9) according to the tightening torque:</p> <ul style="list-style-type: none"> <li>• 1": Tab. 9.82</li> </ul>
57	Undo and remove the lower screws (31).
58	Remove the blind flange (4) or any accessories.
59	<p>Remove the O-ring (37) from the blind flange (4) and replace it, lubricating it with synthetic grease.</p> <p><b>NOTICE!</b> Before inserting the replacement O-ring, clean the retaining slots with a cleaning solution.</p>

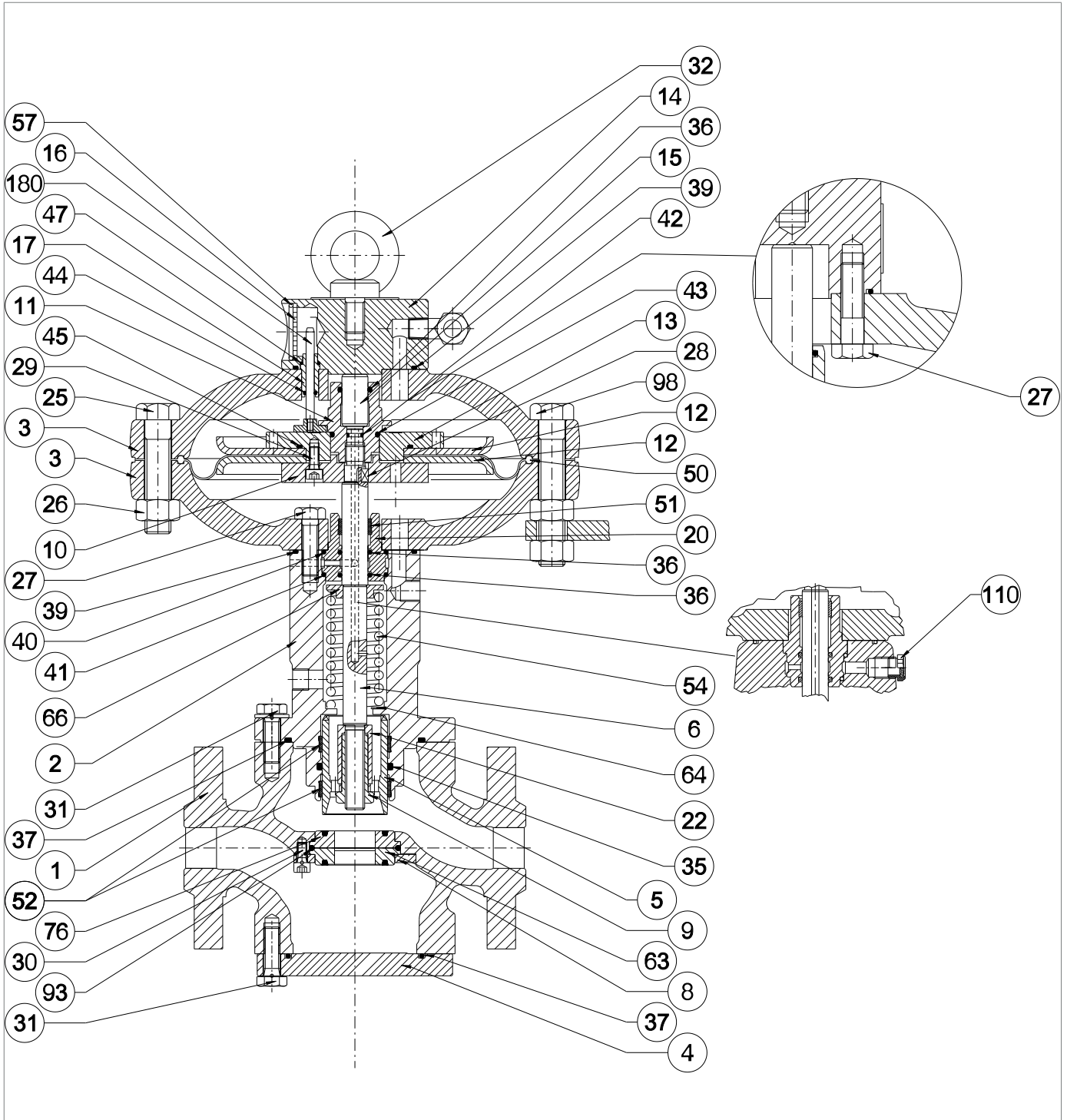

Regulator REFLUX 819/FO 1"

REFLUX 819/FO

Step	Action
60	Undo and remove the screws (30).
61	Remove the shaft collar (8).
62	Remove the reinforced gasket (7). <b>NOTICE!</b> <b>If the SB/82 slam-shut valve is present, remove and replace the conical seat (63).</b>
63	Remove and replace the reinforced gasket (76).
64	Remove the O-ring (93) from the reinforced gasket (76) and replace it, lubricating it with synthetic grease. <b>NOTICE!</b> <b>Before inserting the replacement O-ring, clean the retaining slots with a cleaning solution.</b>
65	Clean the upper and lower supporting surfaces of the body, the flanges, the contact surfaces between the reinforced gasket (76) and the regulator body (1), and between the conical seat (63) and the regulator body (1).
66	Fit the conical seat (63). <b>NOTICE!</b> <b>If the PM/819 monitor is present, position the reinforced gasket (7).</b>
67	Fit the shaft collar (8).
68	Insert and fix the screws (30) according to the following tightening torque: • 1": Tab. 9.82 <b>NOTICE!</b> <b>Tighten the screws according to the cross diagram in paragraph 9.4.2.2.</b>
69	Fit the blind flange (4) or any accessory.
70	Insert and fix the lower screws (31) according to the following tightening torques: • 1": Tab. 9.82 <b>NOTICE!</b> <b>Tighten the screws according to the cross diagram in paragraph 9.4.2.2.</b>
71	Position the control head on the regulator body (1).
72	Insert and fix the upper screws (31) according to the following tightening torques: • 1": Tab. 9.82 <b>NOTICE!</b> <b>Tighten the screws according to the cross diagram in paragraph 9.4.2.2.</b>
73	Check that the indicator rod (180) is in the 100% position in relation to the indicator slide (16).

Tab. 9.127

**WARNING!**

**Ensure that all parts have been fitted correctly.**

9.4.3.2 - REGULATOR REFLUX 819/FO 2" - 3"

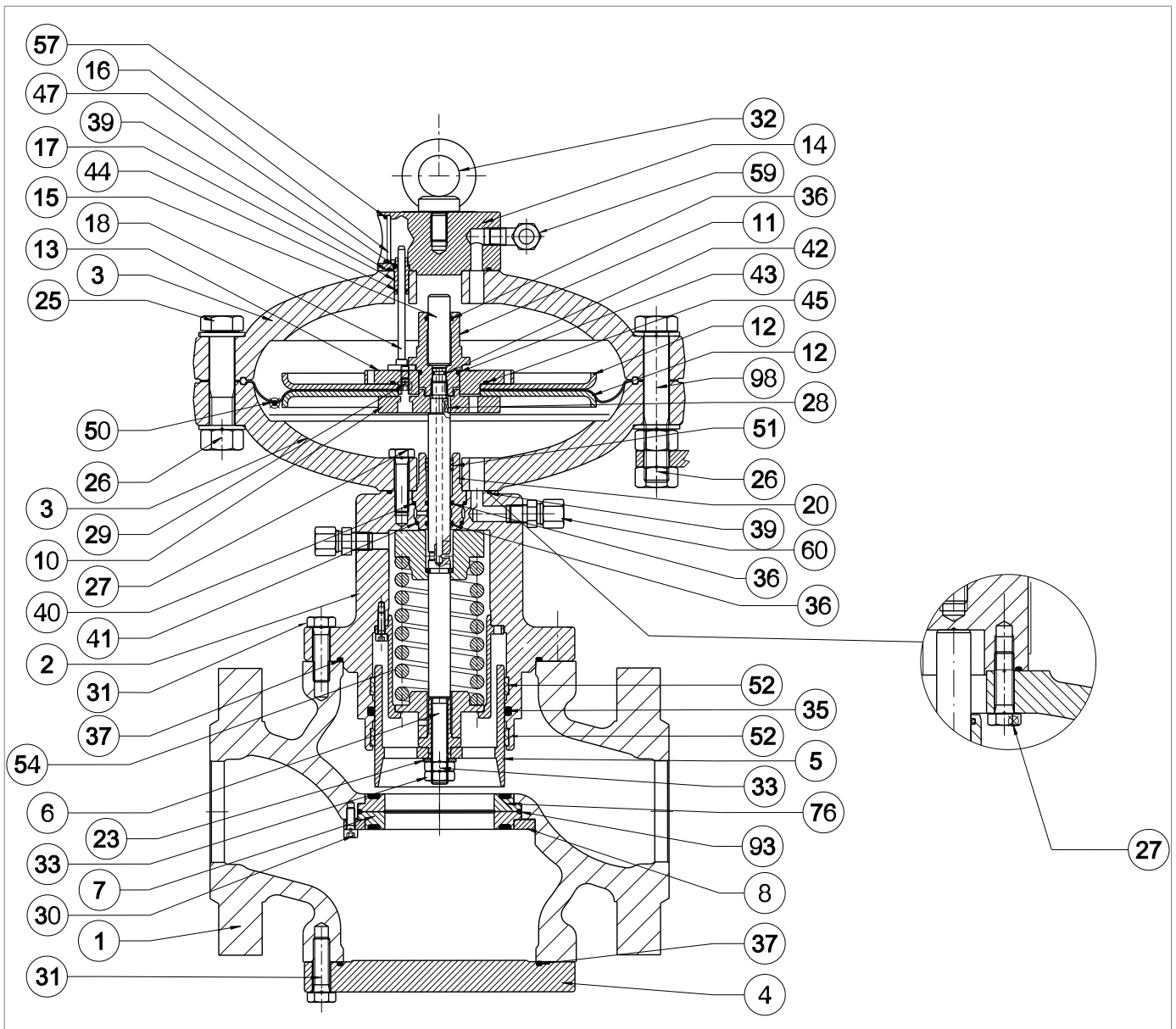
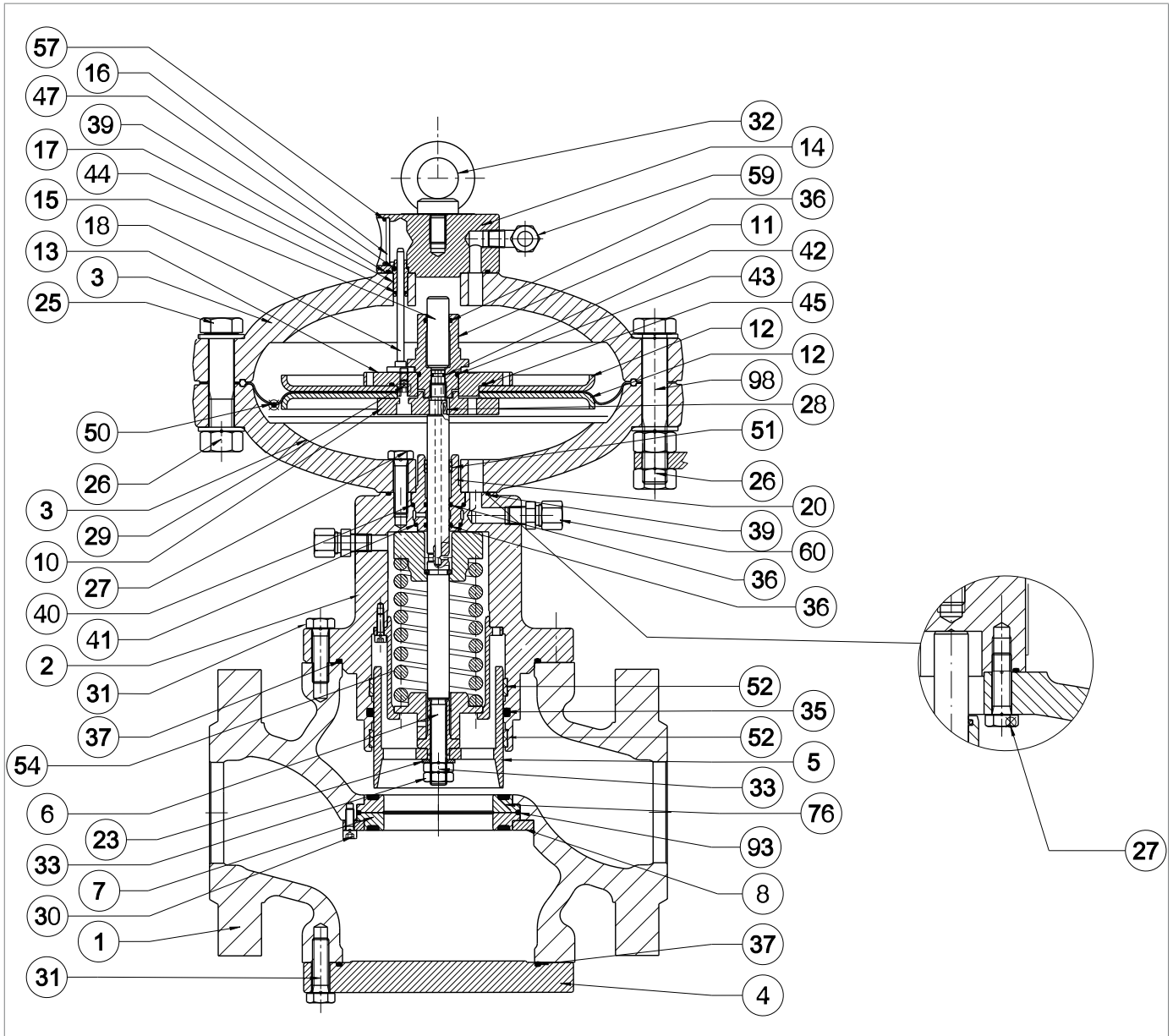

Fig. 9.56. Regulator REFLUX 819/FO 2" - 3"

Step	Action
1	<p>Unscrew and remove the upper screws (31) that secure the control head to the regulator body (1).</p> <p><b>! NOTICE!</b> <b>Support the head assembly during this step to avoid falls.</b></p>
2	<p>Remove the control head and place it on its side in a plane with an impact-resistant surface.</p> <p><b>! NOTICE!</b> <b>Take care not to damage the plug profile (5).</b></p>
3	<p>Remove the O-ring (37) from the plug guide (2) and replace it, lubricating it with synthetic grease.</p> <p><b>! NOTICE!</b> <b>Before inserting the replacement O-ring, clean the retaining slots with a cleaning solution.</b></p>
4	<p>Unscrew and remove the nuts (33) together with the washer (23).</p> <p><b>! NOTICE!</b> <b>During this phase, the spring (54) decompresses and pushes the plug (5) outwards.</b></p>
5	<p>Remove the plug (5) from the plug guide (2) and place it on a table with an impact-resistant surface.</p> <p><b>! NOTICE!</b> <b>Take care not to damage the plug profile (5).</b></p>
6	<p>Remove the O-rings (36) from the stem guide (20) and replace them, lubricating them with silicon grease.</p> <p><b>! NOTICE!</b> <b>Before inserting the replacement O-rings, clean the retaining slots with a cleaning solution.</b></p>
7	<p>Remove the O-rings (40, 41) from the stem guide (20) and replace them, lubricating them with synthetic grease.</p> <p><b>! NOTICE!</b> <b>Before inserting the replacement O-rings, clean the retaining slots with a cleaning solution.</b></p>
8	<p>Remove and replace the I/DWR rings (52) from the plug guide (2).</p> <p><b>! NOTICE!</b> <b>Before inserting the replacement I/DWR rings, clean the retaining slots with a cleaning solution.</b></p>
9	<p>Remove the O-ring (35) from the plug guide (2) and replace it, lubricating it with synthetic grease.</p> <p><b>! NOTICE!</b> <b>Before inserting the replacement O-ring, clean the retaining slots with a cleaning solution.</b></p>
10	Unscrew and remove the screws (25, 98) together with the nuts (26).
11	Remove the upper cover (3) together with the eyebolt flange (14).
12	Remove the indicator rod (18) from the rod guide (17).
13	Unscrew and remove the screws (27) from the top cover (3).
14	Separate the upper cover (3) from the eyebolt flange (14).
15	Take out the rod guide (17).







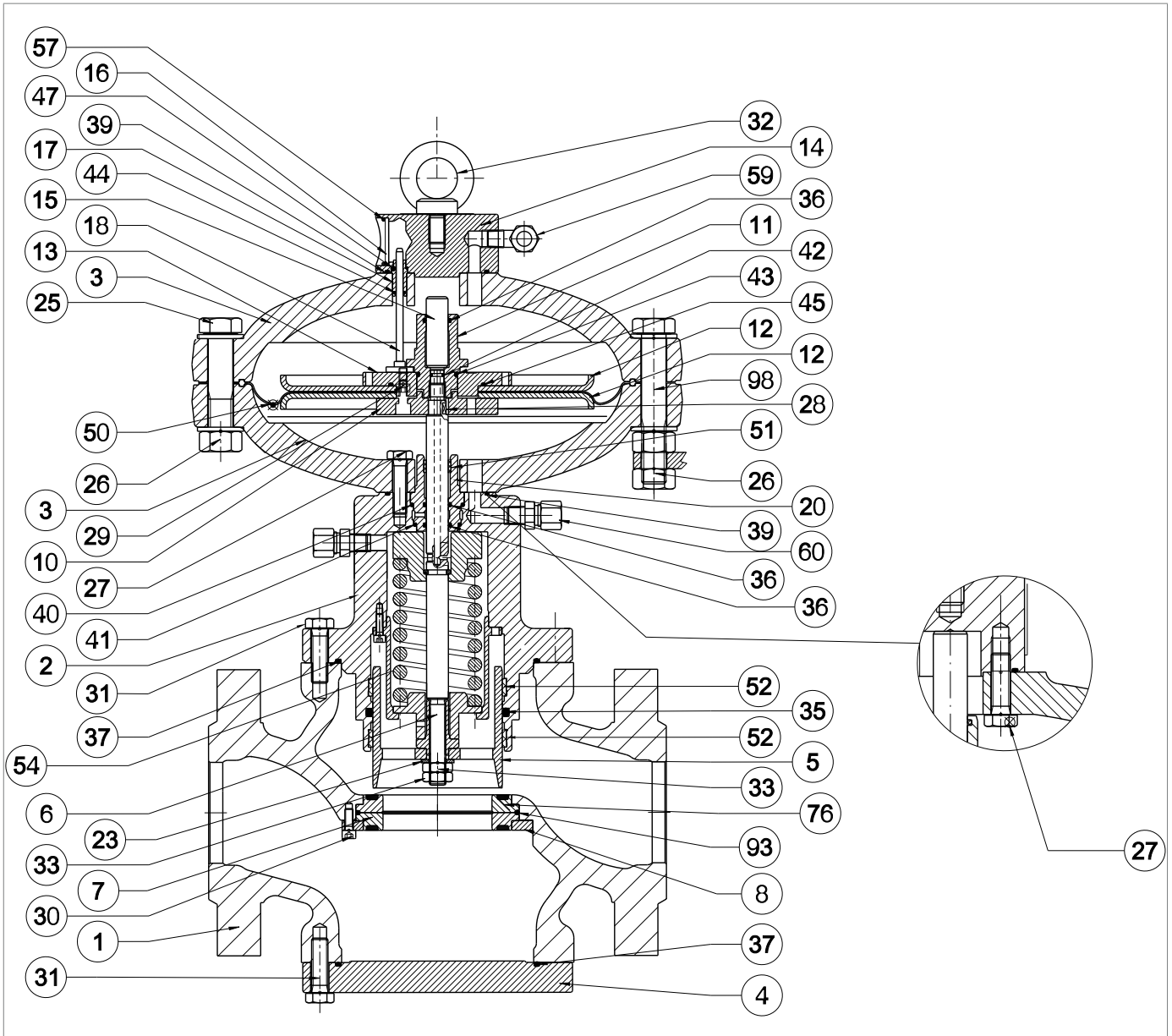



Regulator REFLUX 819/FO 2" - 3"

Step	Action
16	<p>Remove the O-rings (39, 47) from the eyebolt flange (14) and replace them, lubricating them with synthetic grease.</p> <div style="border: 1px solid black; padding: 5px;"> <p><b>NOTICE!</b></p> <p><b>Before inserting the replacement O-ring, clean the retaining slots with a cleaning solution.</b></p> </div>
17	<p>Remove the O-ring (44) from the rod guide (17) and replace it, lubricating it with synthetic grease.</p> <div style="border: 1px solid black; padding: 5px;"> <p><b>NOTICE!</b></p> <p><b>Before inserting the replacement O-ring, clean the retaining slots with a cleaning solution.</b></p> </div>
18	Place the rod guide (17) in the eyebolt flange (14).
19	Assemble the eyebolt flange (14) with the upper lid (3).
20	<p>Insert and fasten the screws (27) in the upper cover (3) according to the tightening torque:</p> <ul style="list-style-type: none"> <li>• 2": Tab. 9.83</li> <li>• 3": Tab. 9.84</li> </ul> <div style="border: 1px solid black; padding: 5px;"> <p><b>NOTICE!</b></p> <p><b>Tighten the screws according to the cross diagram in paragraph 9.4.2.2.</b></p> </div>
21	Insert the indicator rod (18) into the rod guide (17).
22	<p>Unscrew and remove the balancing stem guide (11).</p> <div style="border: 1px solid black; padding: 5px;"> <p><b>NOTICE!</b></p> <p><b>Hold the diaphragm assembly in place by positioning the spanner in the holes in the upper diaphragm support (13).</b></p> </div>
23	<p>Remove the balancing piston (15) from the balancing stem guide (11).</p> <div style="border: 1px solid black; padding: 5px;"> <p><b>NOTICE!</b></p> <p><b>Take care not to damage the surface of the balancing plunger (15).</b></p> </div>
24	<p>Remove and replace the O-rings (36, 43) from the balancing stem guide (11), lubricating them with synthetic grease.</p> <div style="border: 1px solid black; padding: 5px;"> <p><b>NOTICE!</b></p> <p><b>Before inserting the replacement O-rings, clean the retaining slots with a cleaning solution.</b></p> </div>
25	<p>Position the balancing piston (15) in the balancing stem guide (11).</p> <div style="border: 1px solid black; padding: 5px;"> <p><b>NOTICE!</b></p> <ul style="list-style-type: none"> <li>• <b>Clean and lubricate the surface of the balance plunger (15) before insertion</b></li> <li>• <b>Take care not to damage the surface of the balance plunger (15)</b></li> </ul> </div>
26	Take out the diaphragm unit (10, 12, 13, 29, 45, 50).
27	Undo and remove the screws (29) from the lower diaphragm support (10).
28	Remove the lower diaphragm support (10) and the lower diaphragm protection disc (12).
29	Remove the diaphragm (50).
30	Remove the upper diaphragm protection disc (12) from the upper diaphragm holder (13).



Regulator REFLUX 819/FO 2" - 3"

Step	Action
31	Remove and replace the O-ring (45) from the upper diaphragm support (13), lubricating it with synthetic grease. <div style="border: 1px solid black; padding: 5px;">  <b>WARNING!</b>  <b>Before inserting the replacement O-ring, clean the retaining slots with a cleaning solution.</b> </div>
32	Place the upper diaphragm protection disc (12) in the upper diaphragm holder (13).
33	Position the replacement diaphragm (50). <div style="border: 1px solid black; padding: 5px;">  <b>NOTICE!</b>  <b>The concave part of the diaphragm must face the closing pressure chamber (pos. B, fig. 4.2).</b> </div>
34	Put the lower diaphragm protection disc (12) and the lower diaphragm support (10) in place.
35	Apply thread locking glue to insert and fix the screws (29) according to the following tightening torque: <ul style="list-style-type: none"> <li>• 2": Tab. 9.83</li> <li>• 3": Tab. 9.84</li> </ul> <div style="border: 1px solid black; padding: 5px;">  <b>NOTICE!</b>  <b>Tighten the screws according to the cross diagram in paragraph 9.4.2.2.</b> </div>
36	Unscrew and remove the screws (27) from the lower cover (3).
37	Remove the lower cover (3).
38	Remove the O-ring (39) from the plug guide (2) and replace it, lubricating it with synthetic grease. <div style="border: 1px solid black; padding: 5px;">  <b>NOTICE!</b>  <b>Before inserting the replacement O-ring, clean the retaining slots with a cleaning solution.</b> </div>
39	Remove stem guide (20).
40	Remove and replace the I/DWR rings (51) from the stem guide (20). <div style="border: 1px solid black; padding: 5px;">  <b>NOTICE!</b>  <b>Before inserting the replacement I/DWR, clean the retaining slots with a cleaning solution.</b> </div>
41	Remove the O-ring (42) from the stem (6) and replace it, lubricating it with synthetic grease. <div style="border: 1px solid black; padding: 5px;">  <b>NOTICE!</b>  <b>Before inserting the replacement O-ring, clean the retaining slots with a cleaning solution.</b> </div>
42	Position the stem guide (20). <div style="border: 1px solid black; padding: 5px;">  <b>NOTICE!</b> <ul style="list-style-type: none"> <li>• <b>Lubricate the stem surface (6) with silicone grease</b></li> <li>• <b>The key (28) must be in the correct position in the stem (6)</b></li> </ul> </div>
43	Place the lower cover (3) on the plug guide (2). <div style="border: 1px solid black; padding: 5px;">  <b>NOTICE!</b>  <b>Match the hole for the passage of the loading pressure to the similar one on the plug guide.</b> </div>

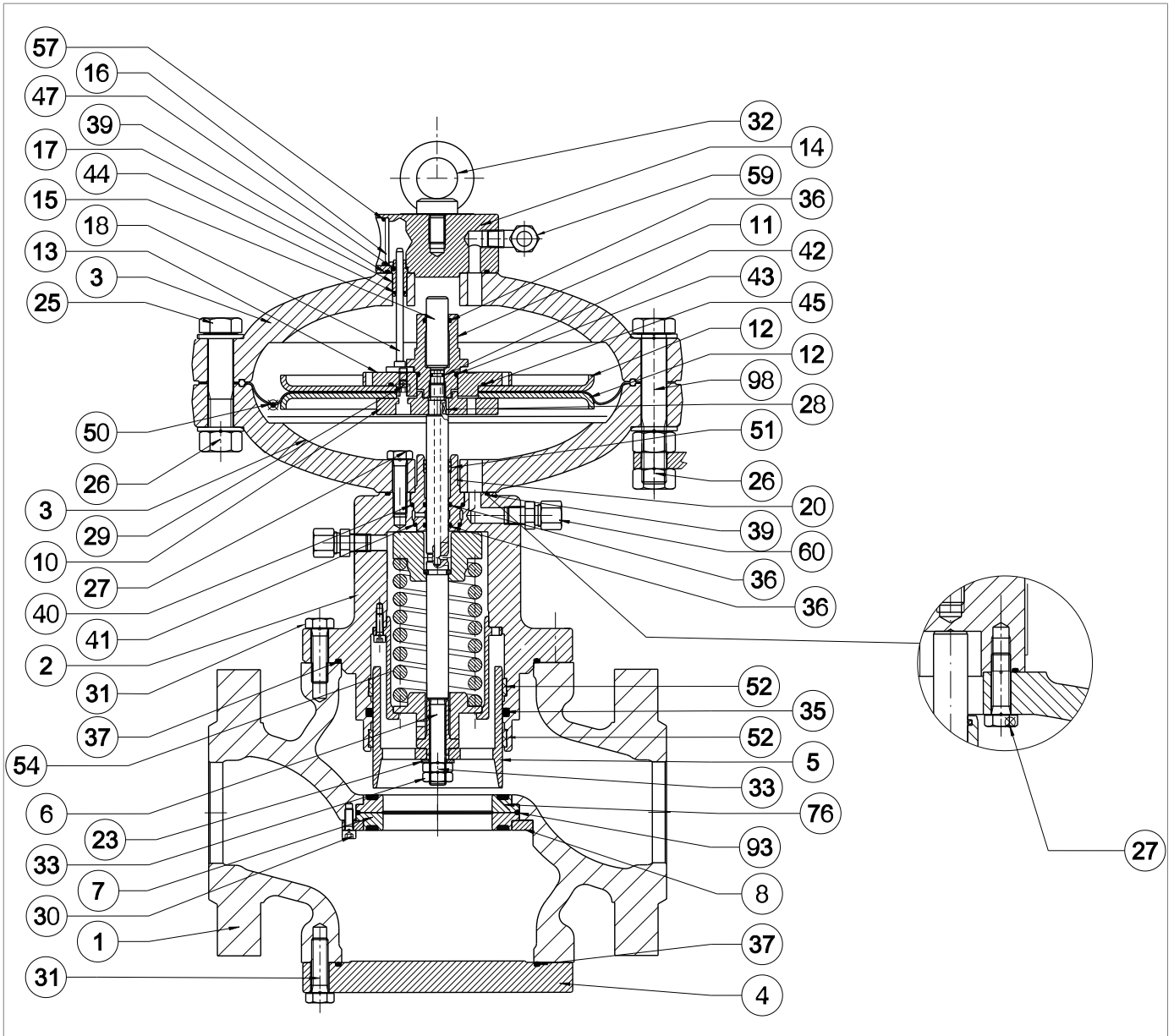

Regulator REFLUX 819/FO 2" - 3"

Step	Action
44	<p>Insert and fasten the lower screws (27) in the lower cover (3), according to the tightening torque:</p> <ul style="list-style-type: none"> <li>• 2": Tab. 9.83</li> <li>• 3": Tab. 9.84</li> </ul> <p><b>NOTICE!</b></p> <p><b>Tighten the screws according to the cross diagram in paragraph 9.4.2.2.</b></p>
45	Put the diaphragm unit in place (10, 12, 13, 21, 29, 45, 50).
46	<p>Insert and secure the balancing stem guide (11) according to the tightening torque:</p> <ul style="list-style-type: none"> <li>• 2": Tab. 9.83</li> <li>• 3": Tab. 9.84</li> </ul> <p><b>NOTICE!</b></p> <p><b>Hold the diaphragm assembly in place by positioning the spanner in the holes in the upper diaphragm support (13).</b></p>
47	<p>Position the upper cover (3), taking care to position the indicator stem (18) in the space between the upper diaphragm support (13) and the balance stem guide (11).</p> <p><b>NOTICE!</b></p> <p><b>The flange travel indicator must be visible and perpendicular to the gas flow</b></p>
48	<p>Insert and fasten the screws (25, 98) with the nuts (26) according to the tightening torque:</p> <ul style="list-style-type: none"> <li>• 2": Tab. 9.83</li> <li>• 3": Tab. 9.84</li> </ul> <p><b>NOTICE!</b></p> <p><b>Tighten the screws according to the cross diagram in paragraph 9.4.2.2.</b></p>
49	<p>Insert the plug (5) into the plug guide (2).</p> <p><b>NOTICE!</b></p> <p><b>Before inserting the plug (5), clean and lubricate the surface with silicone grease.</b></p>
50	Insert the washer (23).
51	<p>Insert and secure the locking nuts (33), applying threadlocking glue, according to the tightening torque:</p> <ul style="list-style-type: none"> <li>• 2": Tab. 9.83</li> <li>• 3": Tab. 9.84</li> </ul> <p><b>NOTICE!</b></p> <p><b>During this phase, manually compress the spring (54).</b></p>
52	<p>Undo and remove the lower screws (31).</p> <p><b>NOTICE!</b></p> <p><b>During this step, take care to support the blind flange (4).</b></p>
53	<p>Remove the blind flange (4) or any accessories.</p> <p><b>NOTICE!</b></p> <p><b>During this step, take care to support the blind flange (4).</b></p>
54	<p>Remove the O-ring (37) from the blind flange (4) and replace it, lubricating it with synthetic grease.</p> <p><b>NOTICE!</b></p> <p><b>Before inserting the replacement O-ring, clean the retaining slots with a cleaning solution.</b></p>

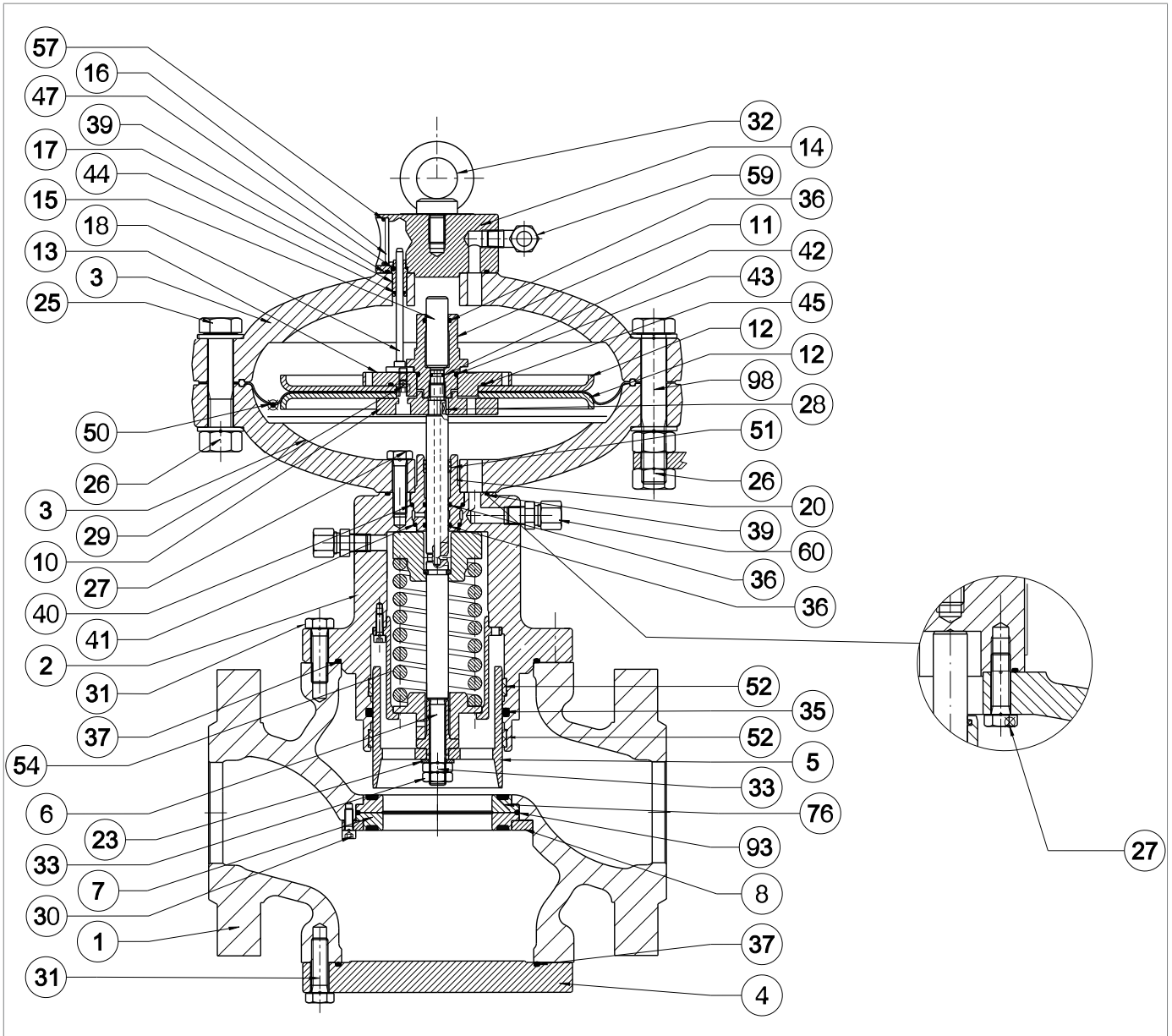

Regulator REFLUX 819/FO 2" - 3"

Step	Action
55	<p>Unscrew and remove screws (30), shaft collar (8), reinforced gasket (76), conical seat (63) and O-ring (93).</p> <p><b>! NOTICE!</b></p> <ul style="list-style-type: none"> <li>• <b>Take care that the upper seal does not fall off.</b></li> <li>• <b>If the SB/82 slam-shut valve is fitted, the conical seat replaces the reinforced gasket (63).</b></li> </ul>
56	<p>Remove the O-ring (93) from the reinforced gasket (76) and replace it, lubricating it with synthetic grease.</p> <p><b>! NOTICE!</b></p> <p><b>Before inserting the replacement O-ring, clean the retaining slots with a cleaning solution.</b></p>
57	<p>Clean the upper and lower supporting surfaces of the body, the flanges, the contact surfaces between the reinforced gasket (76) and the regulator body (1), and between the conical seat (63) and the regulator body (1).</p>
58	<p>Position the reinforced gaskets (7, 76) and the shaft collar (8).</p> <p><b>! NOTICE!</b></p> <p><b>If the SB/82 slam-shut valve is fitted, the conical seat (63) replaces the reinforced gasket (7).</b></p>
59	<p>Insert and fix the screws (30) according to the following tightening torque:</p> <ul style="list-style-type: none"> <li>• 2": Tab. 9.83</li> <li>• 3": Tab. 9.84</li> </ul> <p><b>! NOTICE!</b></p> <p><b>Tighten the screws according to the cross diagram in paragraph 9.4.2.2.</b></p>
60	<p>Fit the blind flange (4) or any accessory.</p> <p><b>! NOTICE!</b></p> <p><b>During this step, take care to support the flange (4) or any accessory.</b></p>
61	<p>Insert and fasten the lower screws (31) in the blind flange (4) according to the tightening torque:</p> <ul style="list-style-type: none"> <li>• 2": Tab. 9.83</li> <li>• 3": Tab. 9.84</li> </ul> <p><b>! NOTICE!</b></p> <p><b>Tighten the screws according to the cross diagram in paragraph 9.4.2.2.</b></p>
62	<p>Insert and fasten the upper screws (31) that secure the control head to the regulator body (1), according to the tightening torque:</p> <ul style="list-style-type: none"> <li>• 2": Tab. 9.83</li> <li>• 3": Tab. 9.84</li> </ul> <p><b>! NOTICE!</b></p> <p><b>Tighten the screws according to the cross diagram in paragraph 9.4.2.2.</b></p>
63	<p>Check that the indicator rod (180) is in the 100% position in relation to the indicator slide (16).</p>

Tab. 9.128

**! WARNING!**

**Ensure that all parts have been fitted correctly.**

9.4.3.3 - REGULATOR REFLUX 819/FO 4" - 8"

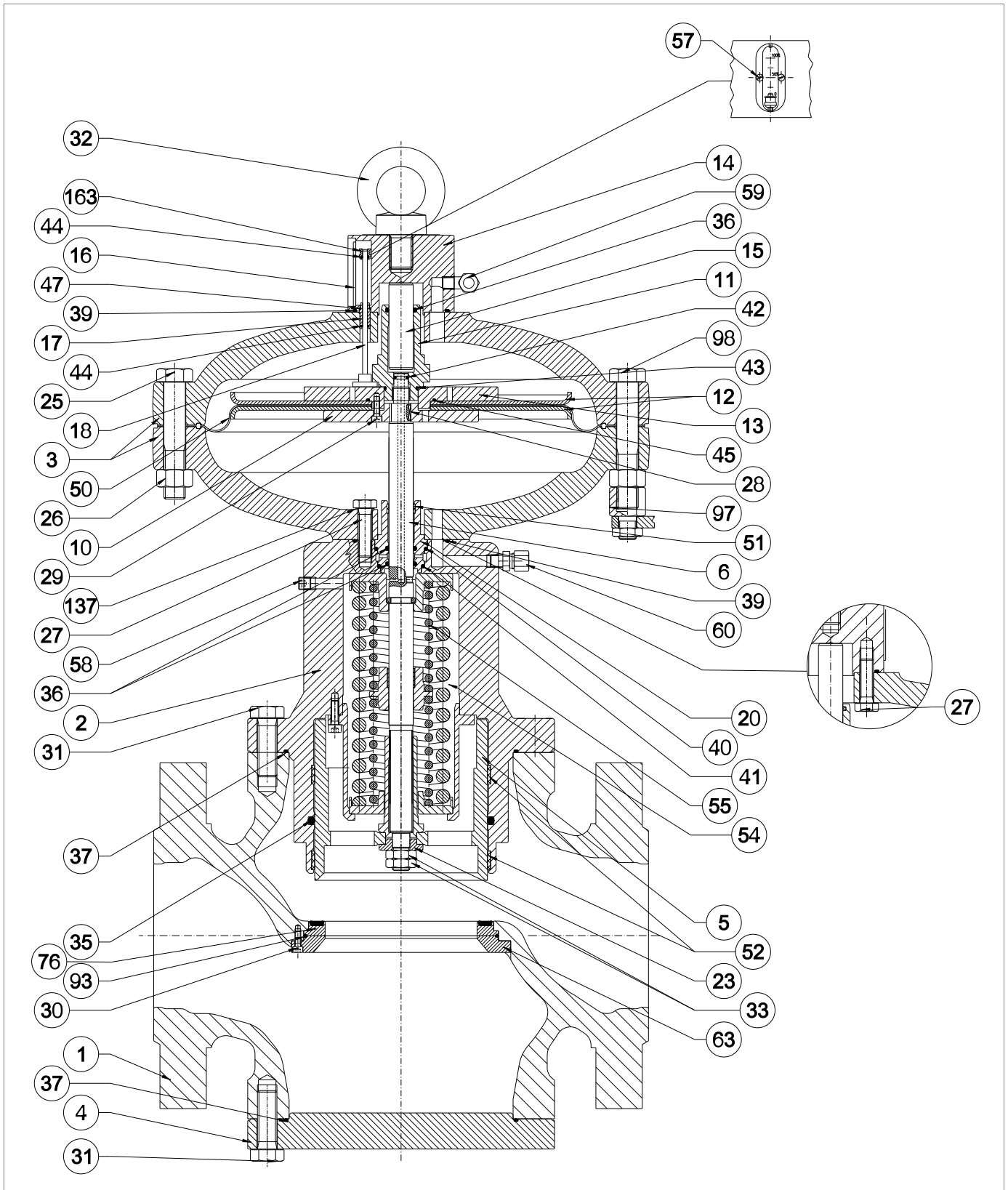
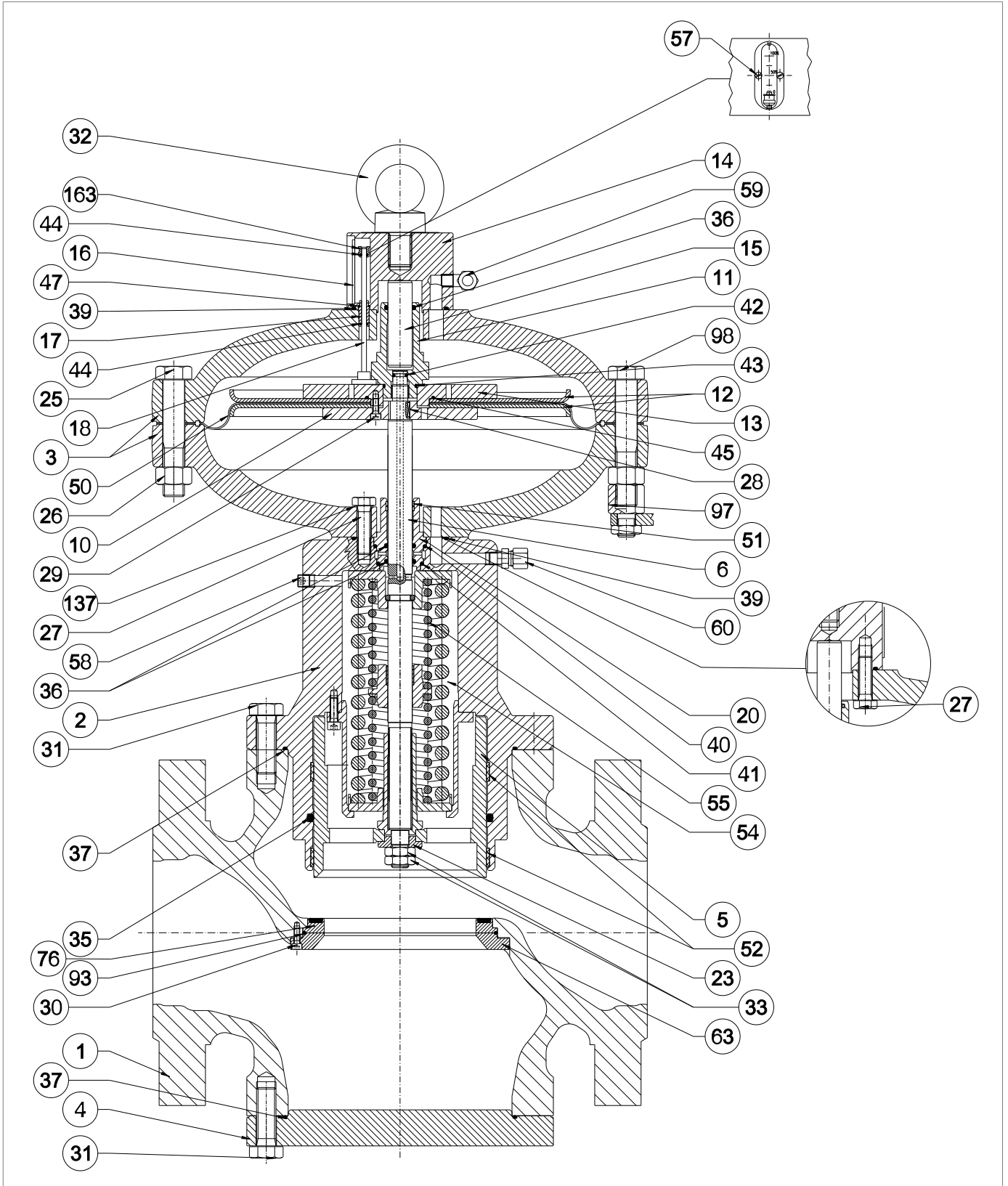

Fig. 9.57. Regulator REFLUX 819/FO 4" - 8"

Step	Action
1	<b>VALID ONLY FOR 6"-8"</b> Unscrew the screws (57) from the eyebolt flange (14).
2	<b>VALID ONLY FOR 6"-8"</b> Remove the indicator slide (16)
3	<b>VALID ONLY FOR 6"-8"</b> Remove the pawl (163).
4	<b>VALID ONLY FOR 6"-8"</b> Remove and replace the O-ring (44) from the pawl (163), lubricating it with synthetic grease. <b>NOTICE!</b> <b>Before inserting the replacement O-ring, clean the retaining slots with a cleaning solution.</b>
5	Unscrew and remove the upper screws (31) that secure the control head to the regulator body (1). <b>NOTICE!</b> <b>Support the head assembly during this step to avoid falls.</b>
6	Remove the control head and place it on its side in a plane with an impact-resistant surface. <b>NOTICE!</b> <b>Take care not to damage the plug profile (5).</b>
7	Remove the O-ring (37) from the plug guide (2) and replace it, lubricating it with synthetic grease. <b>NOTICE!</b> <b>Before inserting the replacement O-ring, clean the retaining slots with a cleaning solution.</b>
8	Unscrew and remove the nuts (33) together with the washer (23).
9	Remove the plug (5) from the plug guide (2) and place it on a table with an impact-resistant surface. <b>NOTICE!</b> <b>Take care not to damage the plug profile (5).</b>
10	Remove and replace the I/DWR rings (52) from the plug guide (2). <b>NOTICE!</b> <b>Before inserting the replacement I/DWR rings, clean the retaining slots with a cleaning solution.</b>
11	Remove the O-ring (35) from the plug guide (2) and replace it, lubricating it with synthetic grease. <b>NOTICE!</b> <b>Before inserting the replacement O-ring, clean the retaining slots with a cleaning solution.</b>
12	Unscrew and remove the screws (25, 98) together with the nuts (26). <b>NOTICE!</b> <b>During this phase, the springs (54, 55) push the stem (6) upwards.</b>
13	Remove the upper lid (3).
14	Remove the indicator rod (18) from the rod guide (17).



Regulator REFLUX 819/FO 4" - 8"





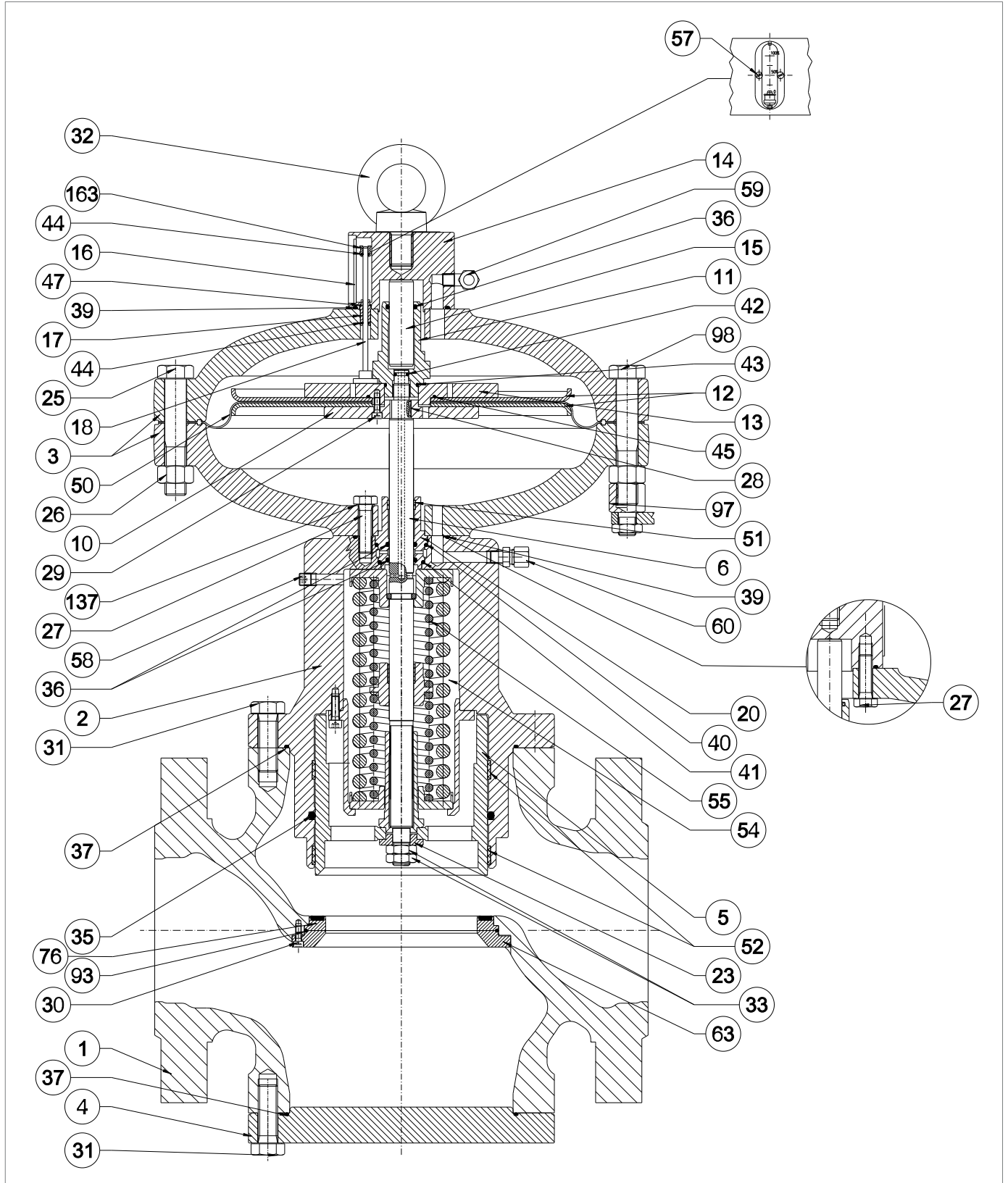

REFLUX 819/FO

Step	Action
15	<p><b>a- ONLY VALID FOR 4"</b> Unscrew and remove the screws (27) from the top cover (3).</p> <p><b>b- ONLY VALID FOR 6", 8"</b> Unscrew and remove the screws (27) together with the washers (137) from the top cover (3).</p>
16	Separate the upper cover (3) from the eyebolt flange (14).
17	Take out the rod guide (17).
18	<p>Remove the O-rings (39, 47) from the eyebolt flange (14) and replace them, lubricating them with synthetic grease.</p> <div style="border: 1px solid blue; padding: 5px;"> <p><b>! NOTICE!</b> <b>Before inserting the replacement O-ring, clean the retaining slots with a cleaning solution.</b></p> </div>
19	<p>Remove the O-ring (44) from the rod guide (17) and replace it, lubricating it with synthetic grease.</p> <div style="border: 1px solid blue; padding: 5px;"> <p><b>! NOTICE!</b> <b>Before inserting the replacement O-ring, clean the retaining slots with a cleaning solution.</b></p> </div>
20	Place the rod guide (17) in the eyebolt flange (14).
21	Assemble the eyebolt flange (14) with the upper lid (3).
22	<p><b>a- ONLY VALID FOR 4"</b> Insert and fasten the screws (27) in the upper cover (3) according to the tightening torque:</p> <ul style="list-style-type: none"> <li>• 4": Tab. 9.85</li> </ul> <p><b>b- ONLY VALID FOR 6", 8"</b> Insert and secure the screws (27) together with the washers (137) in the upper cover (3), according to the tightening torque:</p> <ul style="list-style-type: none"> <li>• 6": Tab. 9.86</li> <li>• 8": Tab. 9.87</li> </ul> <div style="border: 1px solid blue; padding: 5px;"> <p><b>! NOTICE!</b> <b>Tighten the screws according to the cross diagram in paragraph 9.4.2.2.</b></p> </div>
23	Insert the indicator rod (18) into the rod guide (17).
24	<p>Unscrew and remove the balancing stem guide (11).</p> <div style="border: 1px solid blue; padding: 5px;"> <p><b>! NOTICE!</b> <b>Hold the diaphragm assembly in place by positioning the spanner in the holes in the upper diaphragm support (13).</b></p> </div>
25	<p>Remove the balancing piston (15) from the balancing stem guide (11).</p> <div style="border: 1px solid blue; padding: 5px;"> <p><b>! NOTICE!</b> <b>Take care not to damage the surface of the balancing plunger (15).</b></p> </div>
26	<p>Remove and replace the O-rings (36, 43) from the balancing stem guide (11), lubricating them with synthetic grease.</p> <div style="border: 1px solid blue; padding: 5px;"> <p><b>! NOTICE!</b> <b>Before inserting the replacement O-rings, clean the retaining slots with a cleaning solution.</b></p> </div>



Regulator REFLUX 819/FO 4" - 8"

REFLUX 819/FO

Step	Action
27	Position the balancing piston (15) in the balancing stem guide (11). <div style="border: 1px solid black; padding: 5px;">  <b>NOTICE!</b>  <ul style="list-style-type: none"> <li>• <b>Clean and lubricate the surface of the balance plunger (15) before insertion</b></li> <li>• <b>Take care not to damage the surface of the balance plunger (15)</b></li> </ul> </div>
28	Take out the diaphragm unit (10, 12, 13, 29, 45, 50). <div style="border: 1px solid black; padding: 5px;">  <b>NOTICE!</b>  <b>Take care not to lose the key (28).</b> </div>
29	Undo and remove the screws (29) from the lower diaphragm support (10).
30	Remove the lower diaphragm support (10) and the lower diaphragm protection disc (12).
31	Remove the diaphragm (50).
32	Remove the upper diaphragm protection disc (12) from the upper diaphragm holder (13).
33	Remove and replace the O-ring (45) from the upper diaphragm support (13), lubricating it with synthetic grease. <div style="border: 1px solid black; padding: 5px;">  <b>NOTICE!</b>  <b>Before inserting the replacement O-ring, clean the retaining slots with a cleaning solution.</b> </div>
34	Place the upper diaphragm protection disc (12) in the upper diaphragm holder (13).
35	Position the replacement diaphragm (50). <div style="border: 1px solid black; padding: 5px;">  <b>NOTICE!</b>  <b>The concave part of the diaphragm must face the closing pressure chamber (pos. B, fig. 4.2).</b> </div>
36	Put the lower diaphragm protection disc (12) and the lower diaphragm support (10) in place.
37	Apply thread locking glue to insert and fix the screws (29) according to the following tightening torque: <ul style="list-style-type: none"> <li>• 4": Tab. 9.85</li> <li>• 6": Tab. 9.86</li> <li>• 8": Tab. 9.87</li> </ul> <div style="border: 1px solid black; padding: 5px;">  <b>NOTICE!</b>  <b>Tighten the screws according to the cross diagram in paragraph 9.4.2.2.</b> </div>
38	<b>a- ONLY VALID FOR 4"</b> Unscrew and remove the lower part screws (27) from the lower cover (3).  <b>b- ONLY VALID FOR 6", 8"</b> Unscrew and remove the lower part screws (27) together with the washers (137) from the lower cover (3).
39	Remove the lower cover (3).
40	Remove the O-ring (39) from the plug guide (2) and replace it, lubricating it with synthetic grease. <div style="border: 1px solid black; padding: 5px;">  <b>NOTICE!</b>  <b>Before inserting the replacement O-ring, clean the retaining slots with a cleaning solution.</b> </div>
41	Remove stem guide (20).
42	Remove the O-rings (36) from the stem guide (20) and replace them, lubricating them with silicon grease. <div style="border: 1px solid black; padding: 5px;">  <b>NOTICE!</b>  <b>Before inserting the replacement O-rings, clean the retaining slots with a cleaning solution.</b> </div>

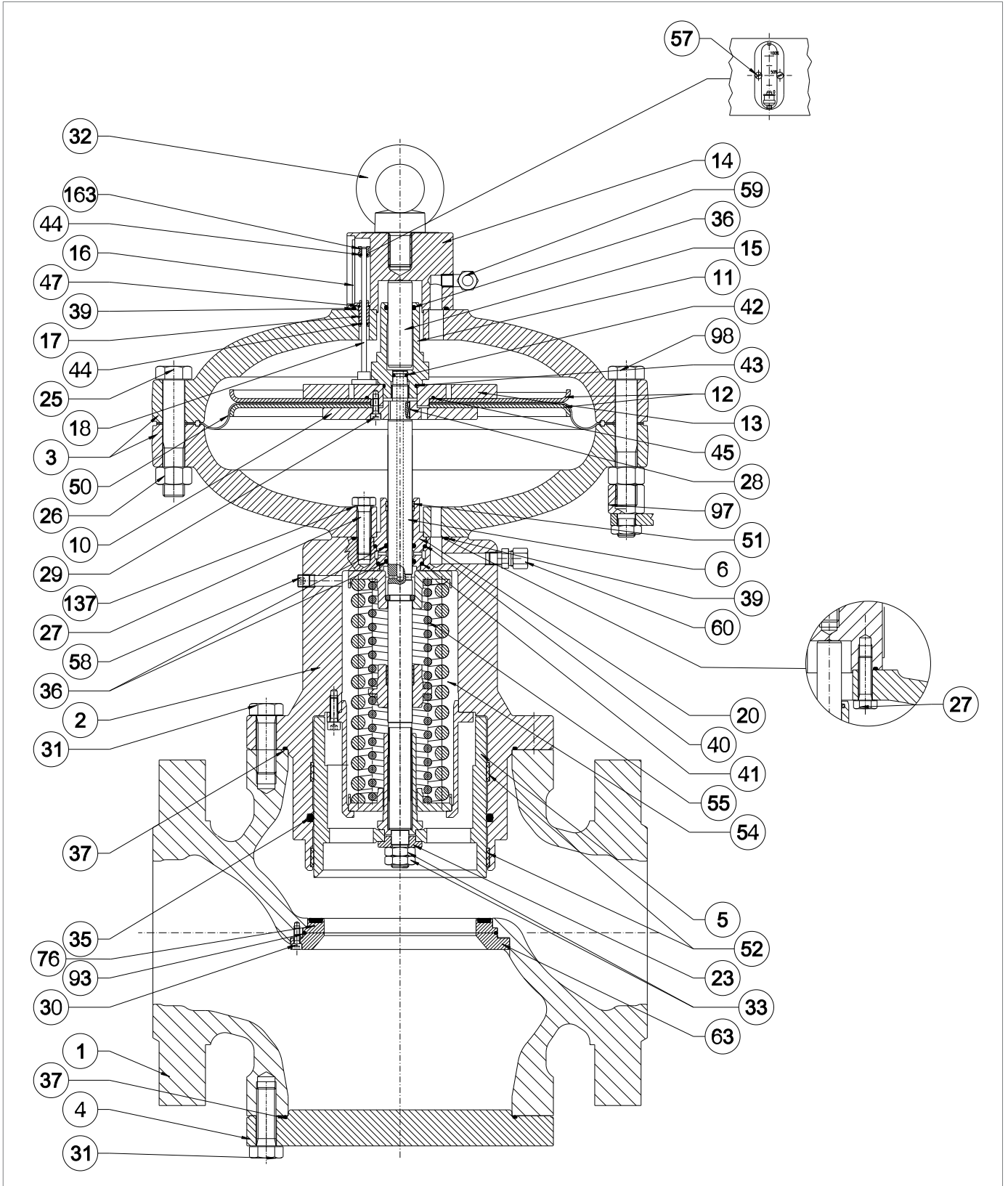

Regulator REFLUX 819/FO 4" - 8"

Step	Action
43	<p>Remove the O-rings (40, 41) from the stem guide (20) and replace them, lubricating them with synthetic grease.</p> <p><b>NOTICE!</b></p> <p><b>Before inserting the replacement O-rings, clean the retaining slots with a cleaning solution.</b></p>
44	<p>Remove and replace the I/DWR rings (51) from the stem guide (20).</p> <p><b>NOTICE!</b></p> <p><b>Before inserting the replacement I/DWR, clean the retaining slots with a cleaning solution.</b></p>
45	<p>Remove the O-ring (42) from the stem (6) and replace it, lubricating it with synthetic grease.</p> <p><b>NOTICE!</b></p> <p><b>Before inserting the replacement O-ring, clean the retaining slots with a cleaning solution.</b></p>
46	<p>Position the stem guide (20).</p> <p><b>NOTICE!</b></p> <ul style="list-style-type: none"> <li>• <b>Lubricate the stem surface (6) with silicone grease</b></li> <li>• <b>The key (28) must be in the correct position in the stem (6)</b></li> </ul>
47	<p>Place the lower cover (3) on the plug guide (2).</p> <p><b>NOTICE!</b></p> <p><b>Match the hole for the passage of the loading pressure to the similar one on the plug guide.</b></p>
48	<p>Insert and fasten the screws (27) in the lower cover (3), according to the tightening torque:</p> <ul style="list-style-type: none"> <li>• 4": Tab. 9.85</li> <li>• 6": Tab. 9.86</li> <li>• 8": Tab. 9.87</li> </ul> <p><b>NOTICE!</b></p> <p><b>Tighten the screws according to the cross diagram in paragraph 9.4.2.2.</b></p>
49	<p>Put the diaphragm unit in place (10, 12, 13, 21, 29, 45, 50).</p>
50	<p>Insert and secure the balancing stem guide (11) according to the tightening torque:</p> <ul style="list-style-type: none"> <li>• 4": Tab. 9.85</li> <li>• 6": Tab. 9.86</li> <li>• 8": Tab. 9.87</li> </ul> <p><b>NOTICE!</b></p> <p><b>Hold the diaphragm assembly in place by positioning the spanner in the holes in the upper diaphragm support (13).</b></p>
51	<p>Position the upper cover (3), taking care to position the indicator stem (18) in the space between the upper diaphragm support (13) and the balance stem guide (11).</p> <p><b>NOTICE!</b></p> <ul style="list-style-type: none"> <li>• <b>The flange travel indicator must be visible and perpendicular to the gas flow</b></li> <li>• <b>During this phase, the springs (54, 55) push the stem (6) upwards</b></li> </ul>

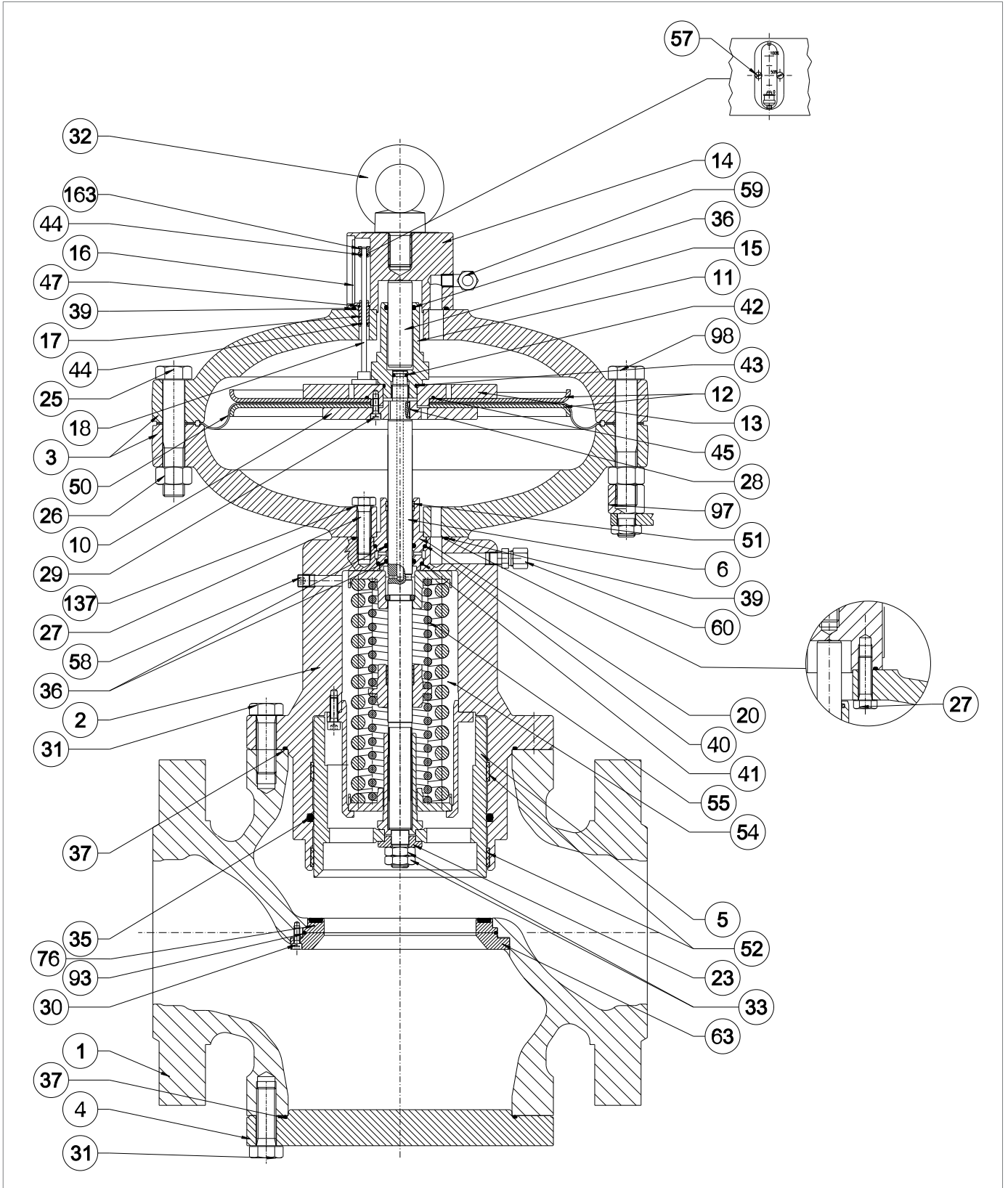

Regulator REFLUX 819/FO 4" - 8"

REFLUX 819/FO

Step	Action
52	<p>Insert and fasten the screws (25, 98) with the nuts (26) according to the tightening torque:</p> <ul style="list-style-type: none"> <li>• 4": Tab. 9.85</li> <li>• 6": Tab. 9.86</li> <li>• 8": Tab. 9.87</li> </ul> <div style="border: 1px solid black; padding: 5px;"> <p><b>! NOTICE!</b></p> <p><b>Tighten the screws according to the cross diagram in paragraph 9.4.2.2.</b></p> </div>
53	Insert the plug (5) into the plug guide (2).
54	Insert the washer (23).
55	<p>Insert and secure the locking nuts (33), applying threadlocking glue, according to the tightening torque:</p> <ul style="list-style-type: none"> <li>• 4": Tab. 9.85</li> <li>• 6": Tab. 9.86</li> <li>• 8": Tab. 9.87</li> </ul>
56	<p>Undo and remove the lower screws (31).</p> <div style="border: 1px solid black; padding: 5px;"> <p><b>! NOTICE!</b></p> <p><b>During this step, take care to support the flange (4) or any accessory.</b></p> </div>
57	<p>Remove the blind flange (4) or any accessories.</p> <div style="border: 1px solid black; padding: 5px;"> <p><b>! NOTICE!</b></p> <p><b>During this step, take care to support the flange (4) or any accessory.</b></p> </div>
58	<p>Remove the O-ring (37) and replace it, lubricating it with synthetic grease.</p> <div style="border: 1px solid black; padding: 5px;"> <p><b>! NOTICE!</b></p> <p><b>Before inserting the replacement O-ring, clean the retaining slots with a cleaning solution.</b></p> </div>
59	<p>Unscrew and remove screws (30), conical seat (63), reinforced gasket (76) and O-ring (93).</p> <div style="border: 1px solid black; padding: 5px;"> <p><b>! NOTICE!</b></p> <ul style="list-style-type: none"> <li>• <b>Take care that the upper seal does not fall off</b></li> <li>• <b>If monitor PM/819 or HB/97 slam-shut valve is fitted, the reinforced gasket (7) replaces the conical seat (63).</b></li> </ul> </div>
60	<p>Remove the O-ring (93) from the reinforced gasket (76) and replace it, lubricating it with synthetic grease.</p> <div style="border: 1px solid black; padding: 5px;"> <p><b>! NOTICE!</b></p> <p><b>Before inserting the replacement O-ring, clean the retaining slots with a cleaning solution.</b></p> </div>
61	Clean the upper and lower supporting surfaces of the body, the flanges, the contact surfaces between the reinforced gasket (76) and the regulator body (1), and between the conical seat (63) and the regulator body (1).
62	<p>Fit the conical seat (63).</p> <div style="border: 1px solid black; padding: 5px;"> <p><b>! NOTICE!</b></p> <p><b>If monitor PM/819 or HB/97 slam-shut valve is fitted, the reinforced gasket (7) replaces the conical seat (63).</b></p> </div>

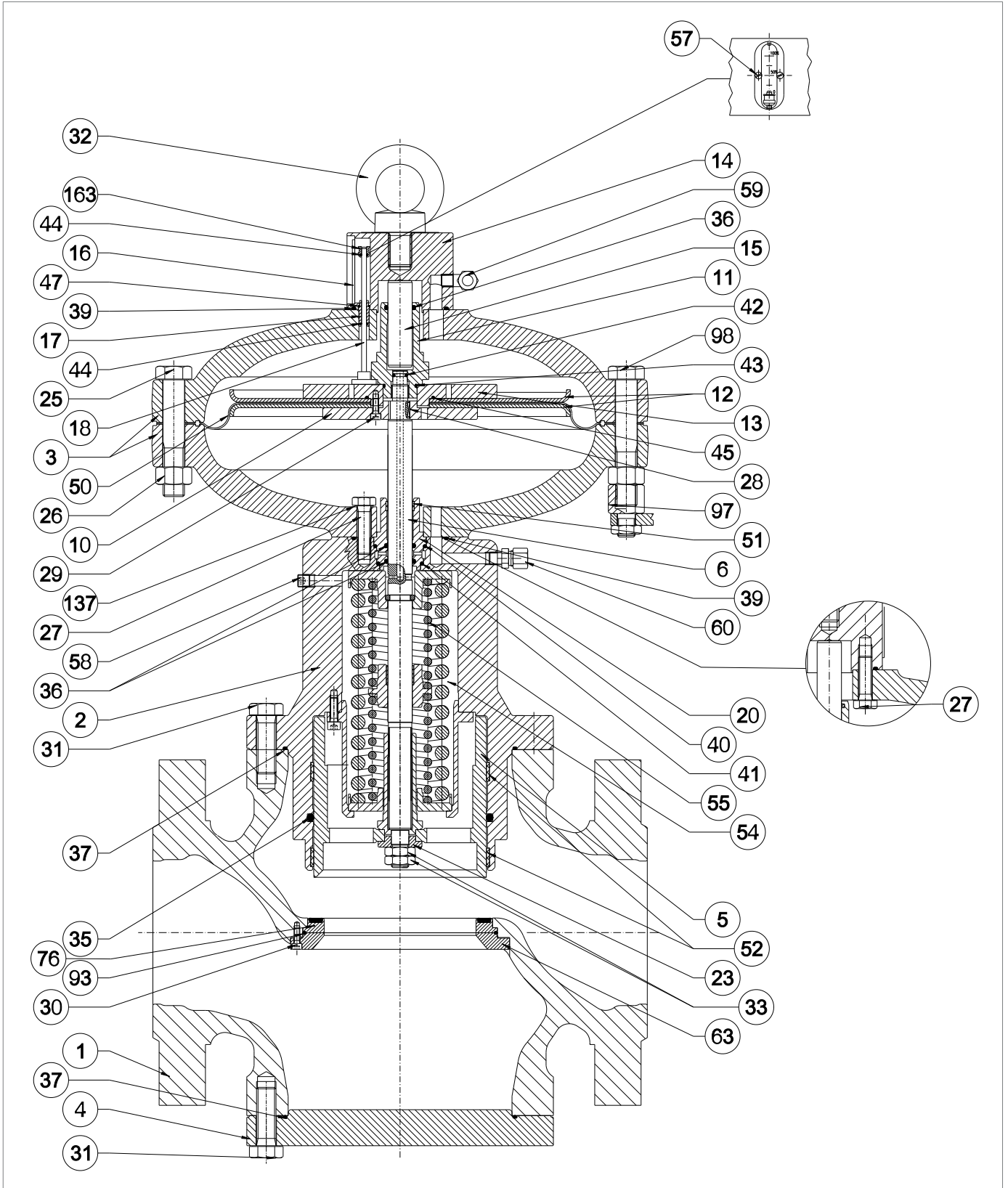

Regulator REFLUX 819/FO 4" - 8"

REFLUX 819/FO

Step	Action
63	<p>Insert and fix the screws (30) according to the following tightening torque:</p> <ul style="list-style-type: none"> <li>• 4": Tab. 9.85</li> <li>• 6": Tab. 9.86</li> <li>• 8": Tab. 9.87</li> </ul> <p><b>NOTICE!</b></p> <p><b>Tighten the screws according to the cross diagram in paragraph 9.4.2.2.</b></p>
64	<p>Fit the blind flange (4) or any accessory.</p> <p><b>NOTICE!</b></p> <p><b>During this step, take care to support the flange (4) or any accessory.</b></p>
65	<p>Insert and fasten the lower screws (31) in the blind flange (4) according to the tightening torque:</p> <ul style="list-style-type: none"> <li>• 4": Tab. 9.85</li> <li>• 6": Tab. 9.86</li> <li>• 8": Tab. 9.87</li> </ul> <p><b>NOTICE!</b></p> <p><b>Tighten the screws according to the cross diagram in paragraph 9.4.2.2.</b></p>
66	<p>Position the control head inside the regulator body (1) with the indicator slide (16) visible and on axis with the gas flow direction.</p> <p><b>NOTICE!</b></p> <p><b>Take care not to damage the plug profile (5).</b></p>
67	<p>Insert and fasten the upper screws (31) that secure the control head to the regulator body (1), according to the tightening torque:</p> <ul style="list-style-type: none"> <li>• 4": Tab. 9.85</li> <li>• 6": Tab. 9.86</li> <li>• 8": Tab. 9.87</li> </ul> <p><b>NOTICE!</b></p> <p><b>Tighten the screws according to the cross diagram in paragraph 9.4.2.2.</b></p>
68	<p><b>VALID ONLY FOR 6"-8"</b></p> <p>Insert the pawl (163) into the rod (18).</p>
69	<p><b>VALID ONLY FOR 6"-8"</b></p> <p>Place the indicator slide (16) in the eyebolt flange (14).</p> <p><b>NOTICE!</b></p> <p><b>Check that the pawl (163) is in position 100% in relation to the indicator slide (16).</b></p>
70	<p><b>VALID ONLY FOR 6"-8"</b></p> <p>Insert and secure the screws (57) in the eyebolt flange (14).</p>
71	<p><b>ONLY VALID FOR 4"</b></p> <p>Check that the indicator rod (18) is in the 100% position in relation to the indicator slide (16).</p>

Tab. 9.129

**WARNING!**

**Ensure that all parts have been fitted correctly.**

9.4.3.4 - REGULATOR REFLUX 819/FO 10"

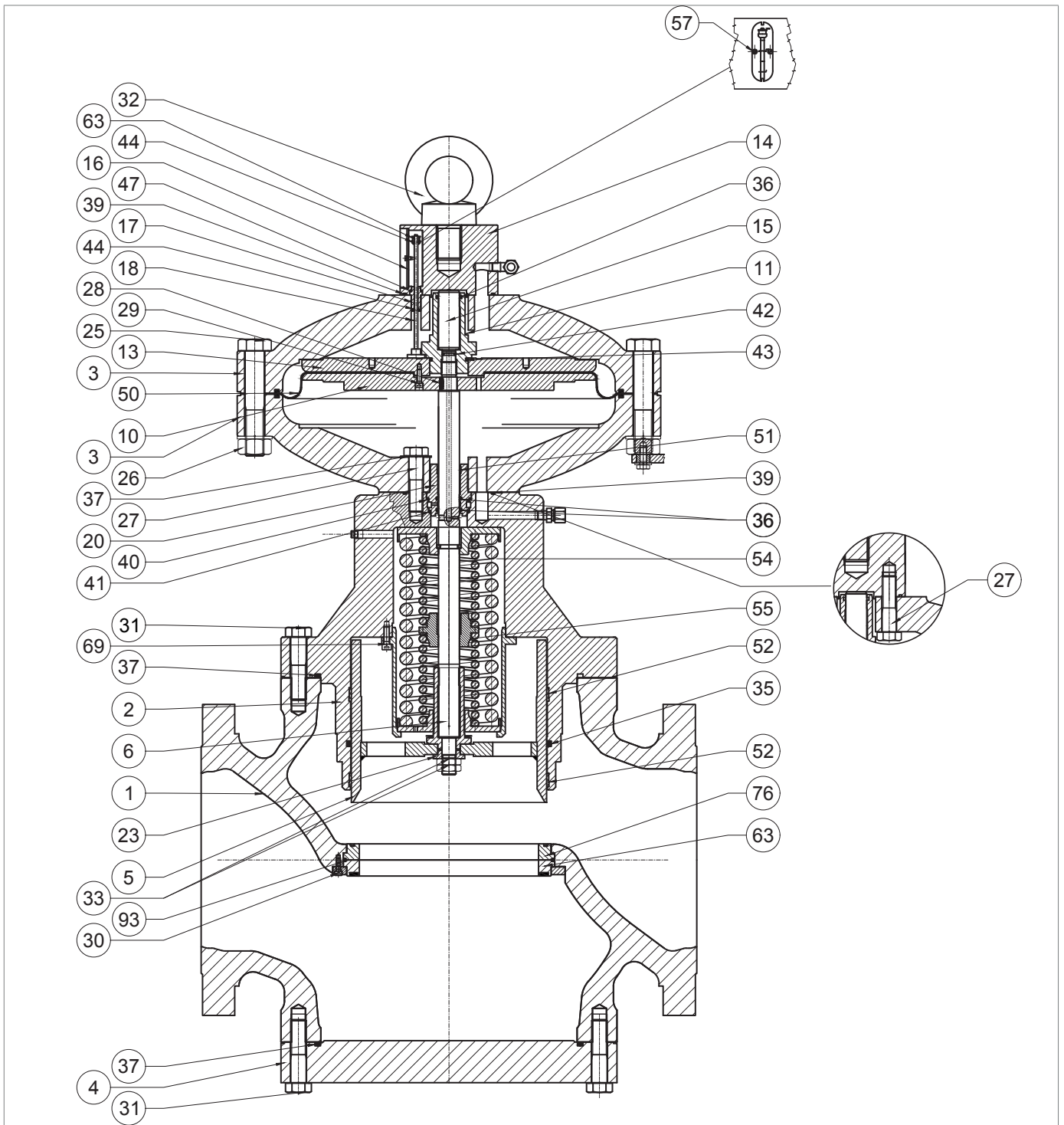
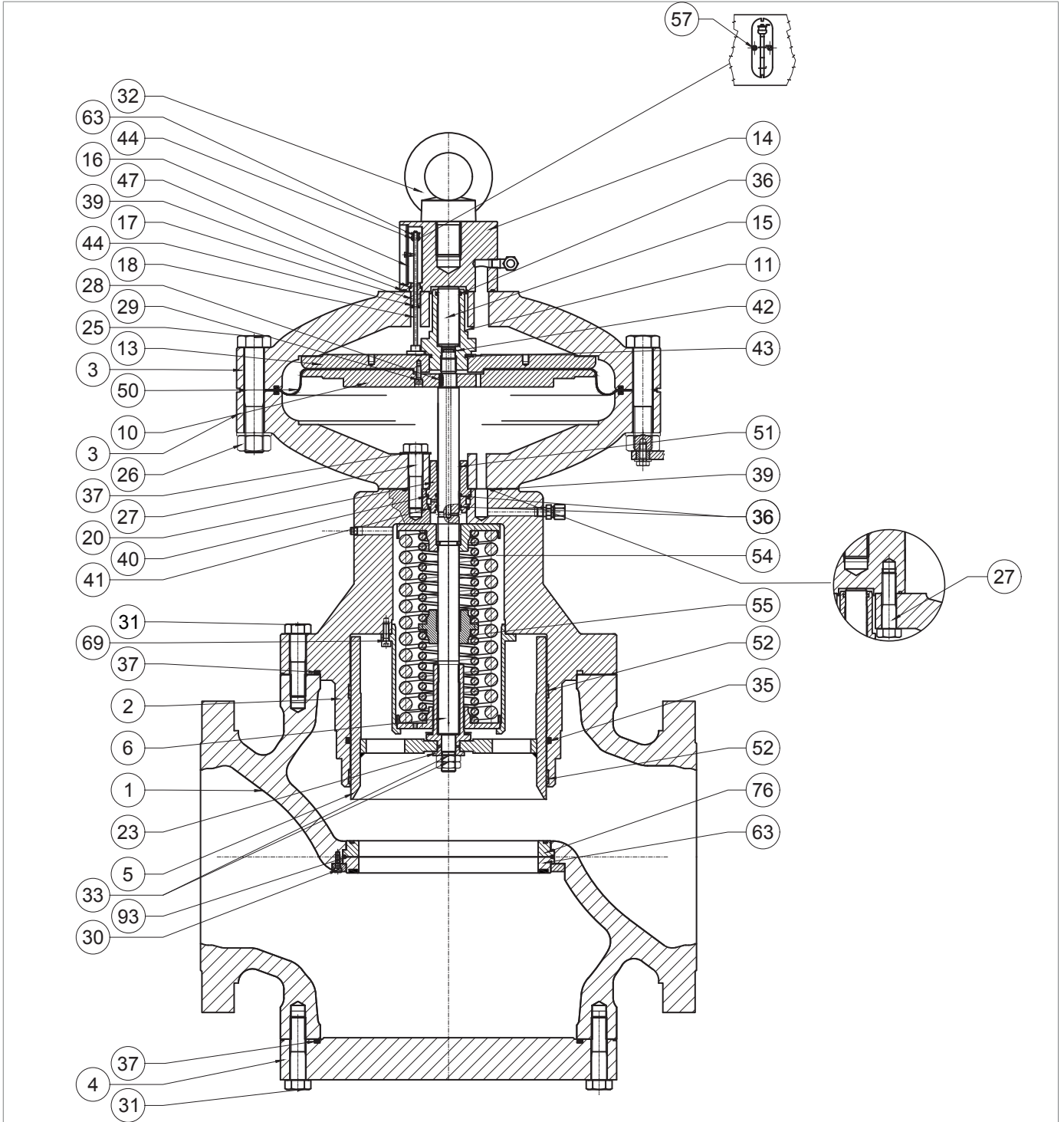

Fig. 9.58. Regulator REFLUX 819/FO 10"

REFLUX 819/FO

Step	Action
1	Unscrew the screws (57) from the eyebolt flange (14).
2	Remove the indicator slide (16)
3	Remove the pawl (163).
4	Remove and replace the O-ring (44) from the pawl (163), lubricating it with synthetic grease. <b>! NOTICE!</b> <b>Before inserting the replacement O-ring, clean the retaining slots with a cleaning solution.</b>
5	Unscrew and remove the upper screws (31) that secure the control head to the regulator body (1). <b>! NOTICE!</b> <b>Support the head assembly during this step to avoid falls.</b>
6	Remove the control head and place it on its side in a plane with an impact-resistant surface. <b>! NOTICE!</b> <b>Take care not to damage the plug profile (5).</b>
7	Remove the O-ring (37) from the plug guide (2) and replace it, lubricating it with synthetic grease. <b>! NOTICE!</b> <b>Before inserting the replacement O-ring, clean the retaining slots with a cleaning solution.</b>
8	Unscrew and remove the locknuts (33) together with the washer (23).
9	Remove the plug (5) and place it on an anti-shock surface. <b>! NOTICE!</b> <b>Do not damage the plug profile (5).</b>
10	Remove and replace the I/DWR rings (52) from the plug guide (2). <b>! NOTICE!</b> <b>Before inserting the replacement I/DWR rings, clean the retaining slots with a cleaning solution.</b>
11	Remove the O-ring (35) from the plug guide (2) and replace it, lubricating it with synthetic grease. <b>! NOTICE!</b> <b>Before inserting the replacement O-ring, clean the retaining slots with a cleaning solution.</b>
12	Unscrew and remove the screws (25) together with the nuts (26). <b>! NOTICE!</b> <b>During this phase, the springs (54, 55) push the stem (6) upwards.</b>
13	Remove the upper cover (3) together with the eyebolt flange (14).
14	Remove the indicator rod (18) from the rod guide (17).
15	Unscrew and remove the screws (27) from the top cover (3).
16	Separate the upper cover (3) from the eyebolt flange (14).
17	Take out the rod guide (17).







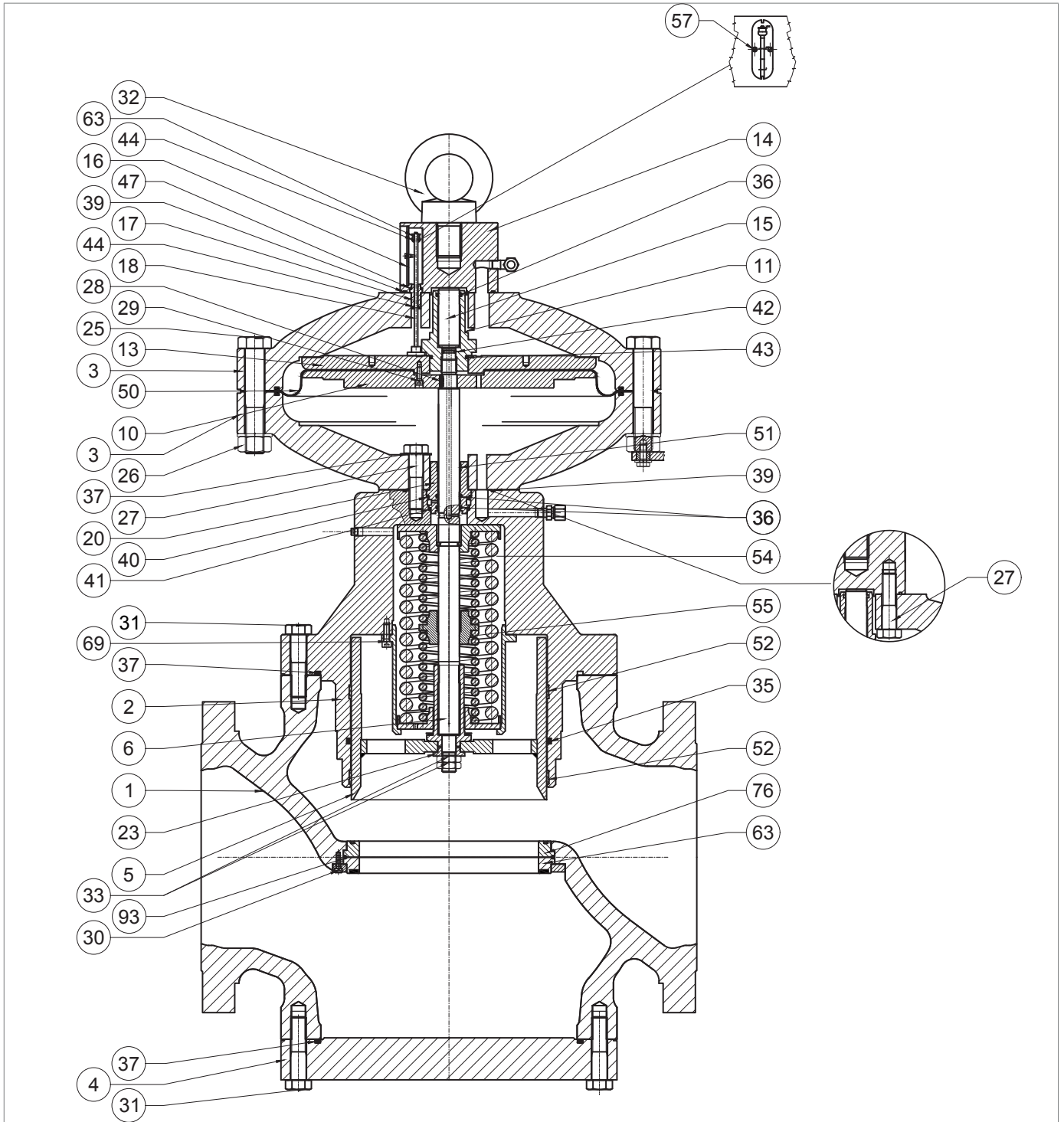



Regulator REFLUX 819/FO 10"

Step	Action
18	<p>Remove the O-rings (39, 47) from the eyebolt flange (14) and replace them, lubricating them with synthetic grease.</p> <div style="border: 1px solid black; padding: 5px;"> <p><b>! NOTICE!</b></p> <p><b>Before inserting the replacement O-ring, clean the retaining slots with a cleaning solution.</b></p> </div>
19	<p>Remove the O-ring (44) from the rod guide (17) and replace it, lubricating it with synthetic grease.</p> <div style="border: 1px solid black; padding: 5px;"> <p><b>! NOTICE!</b></p> <p><b>Before inserting the replacement O-ring, clean the retaining slots with a cleaning solution.</b></p> </div>
20	Place the rod guide (17) in the eyebolt flange (14).
21	Assemble the eyebolt flange (14) with the upper lid (3).
22	<p>Insert and fasten the screws (27) in the upper cover (3) according to the tightening torque:</p> <ul style="list-style-type: none"> <li>• 10": Tab. 9.88</li> </ul> <div style="border: 1px solid black; padding: 5px;"> <p><b>! NOTICE!</b></p> <p><b>Tighten the screws according to the cross diagram in paragraph 9.4.2.2.</b></p> </div>
23	Insert the indicator rod (18) into the rod guide (17).
24	<p>Unscrew and remove the balancing piston guide (11).</p> <div style="border: 1px solid black; padding: 5px;"> <p><b>! NOTICE!</b></p> <p><b>In this step, keep the diaphragm unit still, fitting the compass wrench into the holes in the upper diaphragm support (13).</b></p> </div>
25	<p>Remove the balancing piston (15) from the balancing piston guide (11).</p> <div style="border: 1px solid black; padding: 5px;"> <p><b>! NOTICE!</b></p> <p><b>Take care not to damage the surface of the balancing plunger (15).</b></p> </div>
26	<p>Remove and replace the O-rings (36, 43) from the balancing stem guide (11), lubricating them with synthetic grease.</p> <div style="border: 1px solid black; padding: 5px;"> <p><b>! NOTICE!</b></p> <p><b>Before inserting the replacement O-rings, clean the retaining slots with a cleaning solution.</b></p> </div>
27	<p>Fit the balancing piston (15) from the balancing piston guide (11).</p> <div style="border: 1px solid black; padding: 5px;"> <p><b>! NOTICE!</b></p> <ul style="list-style-type: none"> <li>• <b>Clean and lubricate the surface of the balance plunger (15) before insertion</b></li> <li>• <b>Take care not to damage the surface of the balance plunger (15)</b></li> </ul> </div>
28	<p>Take out the diaphragm unit (10, 12, 13, 21, 29, 45, 50).</p> <div style="border: 1px solid black; padding: 5px;"> <p><b>! NOTICE!</b></p> <p><b>Take care not to lose the key (28).</b></p> </div>
29	Undo and remove the screws (29) from the lower diaphragm support (10).
30	Remove the lower diaphragm support (10).
31	Remove the diaphragm (50).



Regulator REFLUX 819/FO 10"

Step	Action
32	Position the replacement diaphragm (50). <div style="border: 1px solid black; padding: 5px;">  <b>NOTICE!</b>  <b>The concave part of the diaphragm must face the closing pressure chamber (pos. B, fig. 4.2).</b> </div>
33	Position the lower diaphragm holder (10).
34	Apply thread locking glue to insert and fix the screws (29) according to the following tightening torque: <ul style="list-style-type: none"> <li>• 10": Tab. 9.88</li> </ul> <div style="border: 1px solid black; padding: 5px;">  <b>NOTICE!</b>  <b>Tighten the screws according to the cross diagram in paragraph 9.4.2.2.</b> </div>
35	Unscrew and remove the screws (27) together with the serrated washers (37) from the lower cover (3).
36	Remove the lower cover (3).
37	Remove the O-ring (39) from the plug guide (2) and replace it, lubricating it with synthetic grease. <div style="border: 1px solid black; padding: 5px;">  <b>NOTICE!</b>  <b>Before inserting the replacement O-ring, clean the retaining slots with a cleaning solution.</b> </div>
38	Remove the stem guide (20) from the plug guide (2).
39	Remove and replace the I/DWR rings (51) from the stem guide (20). <div style="border: 1px solid black; padding: 5px;">  <b>NOTICE!</b>  <b>Before inserting the replacement I/DWR ring, clean the retaining slots with a cleaning solution.</b> </div>
40	Remove and replace the O-ring (36) from the stem guide (20), lubricating it with silicone grease. <div style="border: 1px solid black; padding: 5px;">  <b>NOTICE!</b>  <b>Before inserting the replacement O-ring, clean the retaining slots with a cleaning solution.</b> </div>
41	Remove the O-rings (40, 41) from the stem guide (20) and replace them, taking care to lubricate them with silicon grease. <div style="border: 1px solid black; padding: 5px;">  <b>NOTICE!</b>  <b>Before inserting the replacement O-rings, clean the retaining slots with a cleaning solution.</b> </div>
42	Remove the O-ring (42) from the stem (6) and replace it, lubricating it with synthetic grease. <div style="border: 1px solid black; padding: 5px;">  <b>NOTICE!</b>  <b>Before inserting the replacement O-ring, clean the retaining slots with a cleaning solution.</b> </div>
43	Position the stem guide (20) in the plug guide (2). <div style="border: 1px solid black; padding: 5px;">  <b>NOTICE!</b>  <ul style="list-style-type: none"> <li>• <b>Lubricate the stem surface (6) with silicone grease</b></li> <li>• <b>The key (28) must be in the correct position in the stem (6)</b></li> </ul> </div>
44	Place the lower cover (3) on the plug guide (2). <div style="border: 1px solid black; padding: 5px;">  <b>NOTICE!</b>  <b>The hole for the passage of the loading pressure must match the similar one on the plug guide.</b> </div>

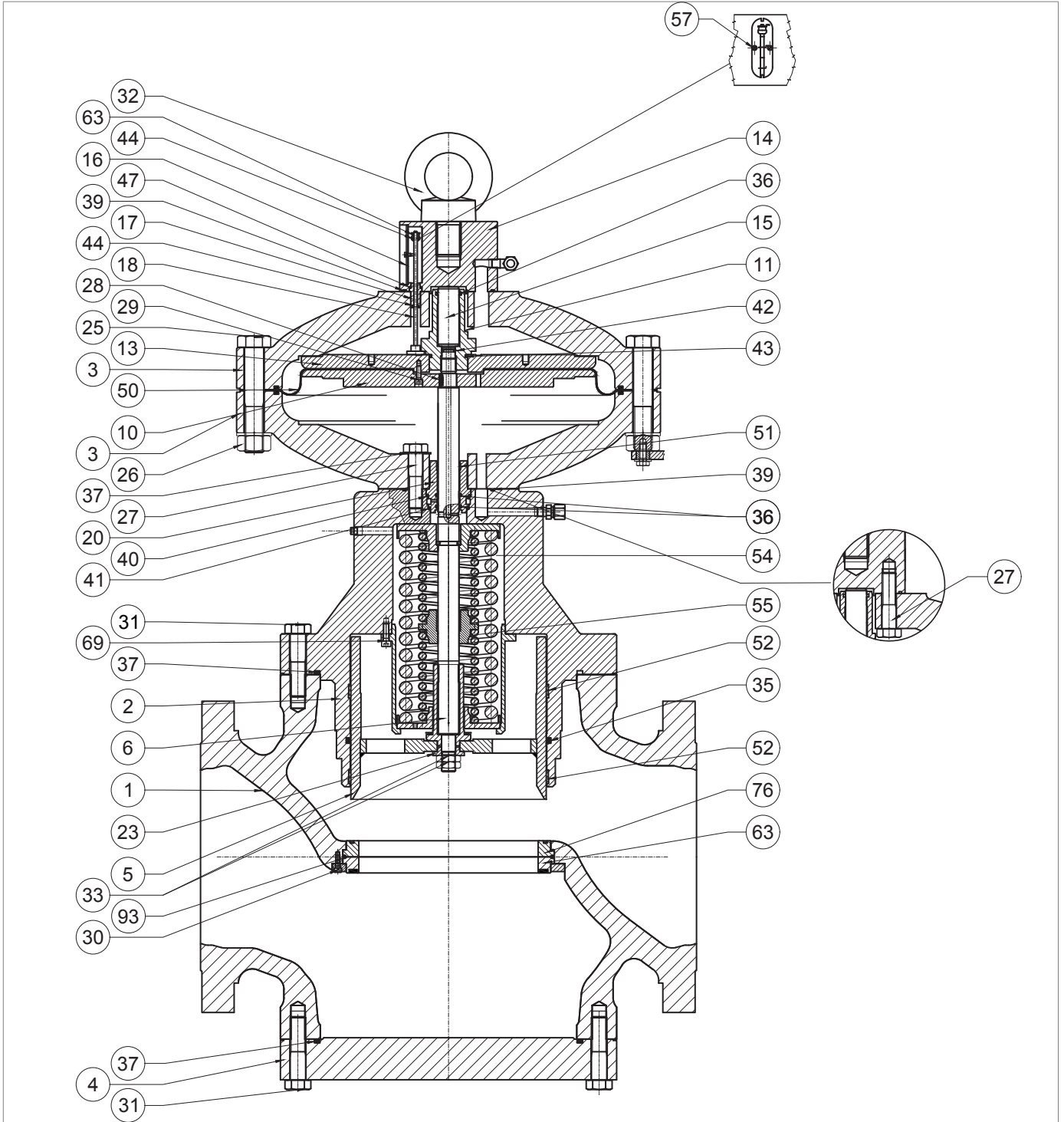

Regulator REFLUX 819/FO 10"

Step	Action
45	<p>Insert and secure the screws (27) together with the washers (37) in the lower cover (3), according to the tightening torque:</p> <ul style="list-style-type: none"> <li>• 10": Tab. 9.88</li> </ul> <p><b>NOTICE!</b></p> <p><b>Tighten the screws according to the cross diagram in paragraph 9.4.2.2.</b></p>
46	<p>Put the diaphragm unit in place (10, 12, 13, 21, 29, 45, 50).</p> <p><b>NOTICE!</b></p> <p><b>Take care not to lose the key (28).</b></p>
47	<p>Insert and secure the balancing stem guide (11) according to the tightening torque:</p> <ul style="list-style-type: none"> <li>• 10": Tab. 9.88</li> </ul> <p><b>NOTICE!</b></p> <p><b>Hold the diaphragm assembly in place and position the spanner in the holes in the upper diaphragm support (13).</b></p>
48	<p>Position the upper cover (3), taking care to position the indicator stem (18) in the space between the upper diaphragm support (13) and the balancing piston guide (11).</p> <p><b>NOTICE!</b></p> <p><b>The flange travel indicator must be visible and perpendicular to the gas flow</b></p>
49	<p>Insert and fasten the screws (25) with the nuts (26) according to the tightening torque:</p> <ul style="list-style-type: none"> <li>• 10": Tab. 9.88</li> </ul> <p><b>NOTICE!</b></p> <ul style="list-style-type: none"> <li>• <b>Tighten the screws according to the cross diagram in paragraph 9.4.2.2</b></li> <li>• <b>During this phase, the springs (54, 55) push the stem (6) upwards.</b></li> </ul>
50	<p>Insert the plug (5) into the plug guide (2).</p> <p><b>NOTICE!</b></p> <p><b>Before inserting the plug (5), clean and lubricate the surface with silicone grease.</b></p>
51	<p>Insert the washer (23).</p>
52	<p>Insert and secure the locking nuts (33), applying threadlocking glue, according to the tightening torque:</p> <ul style="list-style-type: none"> <li>• 10": Tab. 9.88</li> </ul>
53	<p>Unscrew and remove the lower screws (31) from the blind flange (4).</p> <p><b>NOTICE!</b></p> <p><b>During this step, take care to support the flange (4) or any accessory.</b></p>
54	<p>Remove the blind flange (4) or any accessories.</p> <p><b>NOTICE!</b></p> <p><b>During this step, take care to support the flange (4) or any accessory.</b></p>
55	<p>Remove the O-ring (37) from the blind flange (4) and replace it, lubricating it with synthetic grease.</p> <p><b>NOTICE!</b></p> <p><b>Before inserting the replacement O-ring, clean the retaining slots with a cleaning solution.</b></p>

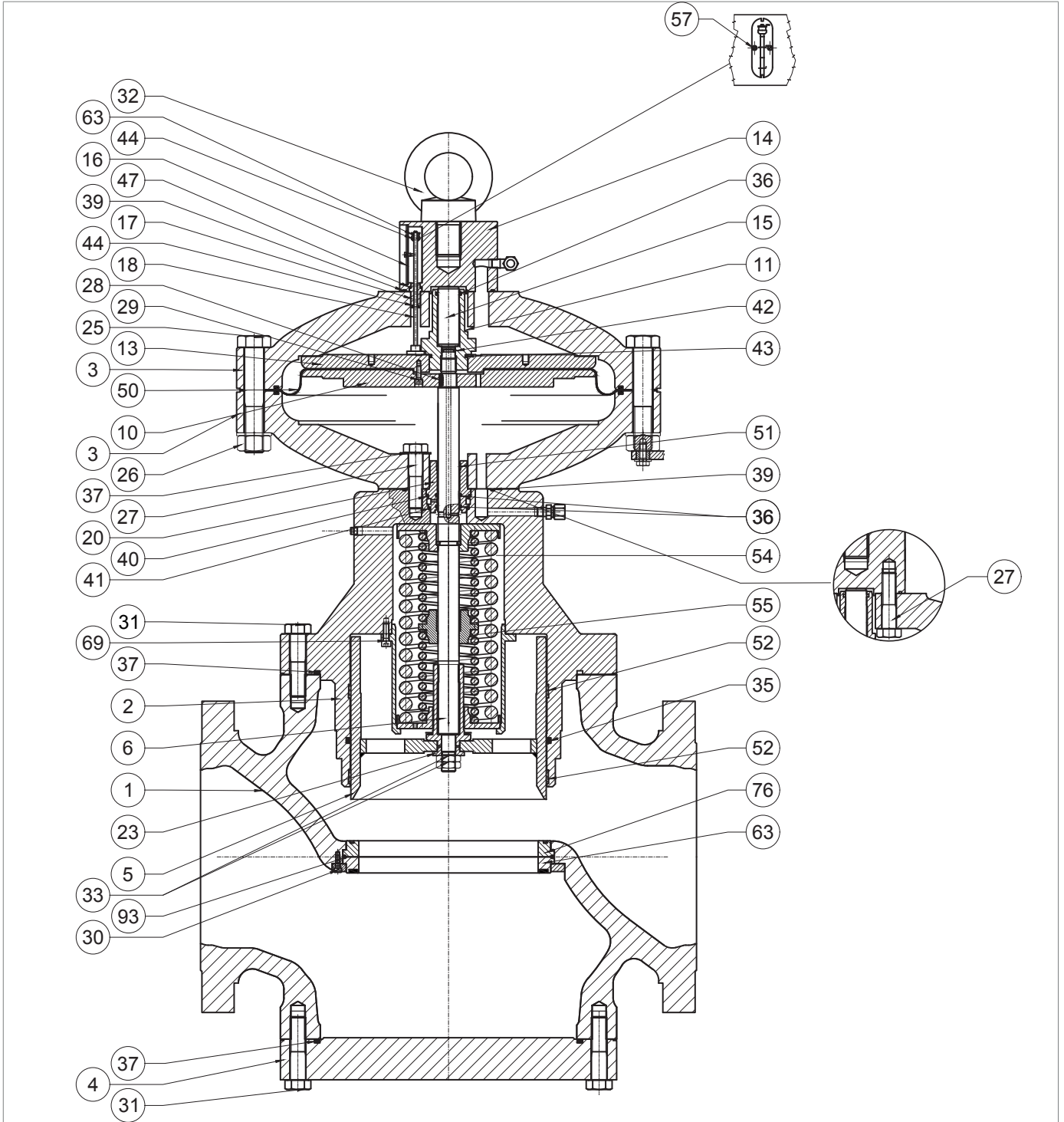

Regulator REFLUX 819/FO 10"

Step	Action
56	<p>Unscrew and remove screws (30), shaft collar (8), reinforced gaskets (7, 76) and O-ring (93).</p> <p><b>NOTICE!</b> Take care that the upper seal does not fall off.</p>
57	<p>Remove the O-ring (93) from the reinforced gasket (7, 76) and replace it, lubricating it with synthetic grease.</p> <p><b>NOTICE!</b> Before inserting the replacement O-ring, clean the retaining slots with a cleaning solution.</p>
58	<p>Clean the upper and lower supporting surfaces of the body, the flanges, the contact surfaces between the reinforced gasket (7) and the regulator body (1), and between the reinforced gasket (76) and the body (1).</p>
59	<p>Position the reinforced gasket (7, 76) and the shaft collar (8).</p>
60	<p>Insert and fix the screws (30) according to the following tightening torque:</p> <ul style="list-style-type: none"> <li>10": Tab. 9.88</li> </ul> <p><b>NOTICE!</b> Tighten the screws according to the cross diagram in paragraph 9.4.2.2.</p>
61	<p>Fit the blind flange (4) or any accessory.</p> <p><b>NOTICE!</b> During this step, take care to support the flange (4) or any accessory.</p>
62	<p>Insert and fasten the lower screws (31) in the blind flange (4) according to the tightening torque:</p> <ul style="list-style-type: none"> <li>10": Tab. 9.88</li> </ul> <p><b>NOTICE!</b> Tighten the screws according to the cross diagram in paragraph 9.4.2.2.</p>
63	<p>Position the control head inside the regulator body (1) with the indicator slide housing (16) visible and perpendicular to the gas flow.</p> <p><b>NOTICE!</b> Take care not to damage the plug profile (5).</p>
64	<p>Insert and fasten the upper screws (31) that secure the control head to the regulator body (1), according to the tightening torque:</p> <ul style="list-style-type: none"> <li>10": Tab. 9.88</li> </ul> <p><b>NOTICE!</b> Tighten the screws according to the cross diagram in paragraph 9.4.2.2.</p>
65	<p>Insert the pawl (163) into the rod (18).</p>
66	<p>Place the indicator slide (16) in the eyebolt flange (14).</p> <p><b>NOTICE!</b> Check that the pawl (163) is in position 100% in relation to the indicator slide (16).</p>
67	<p>Insert and secure the screws (57) in the eyebolt flange (14).</p>

Tab. 9.130

**WARNING!**

Ensure that all parts have been fitted correctly.

9.4.3.5 - REGULATOR REFLUX 819/FO 12"

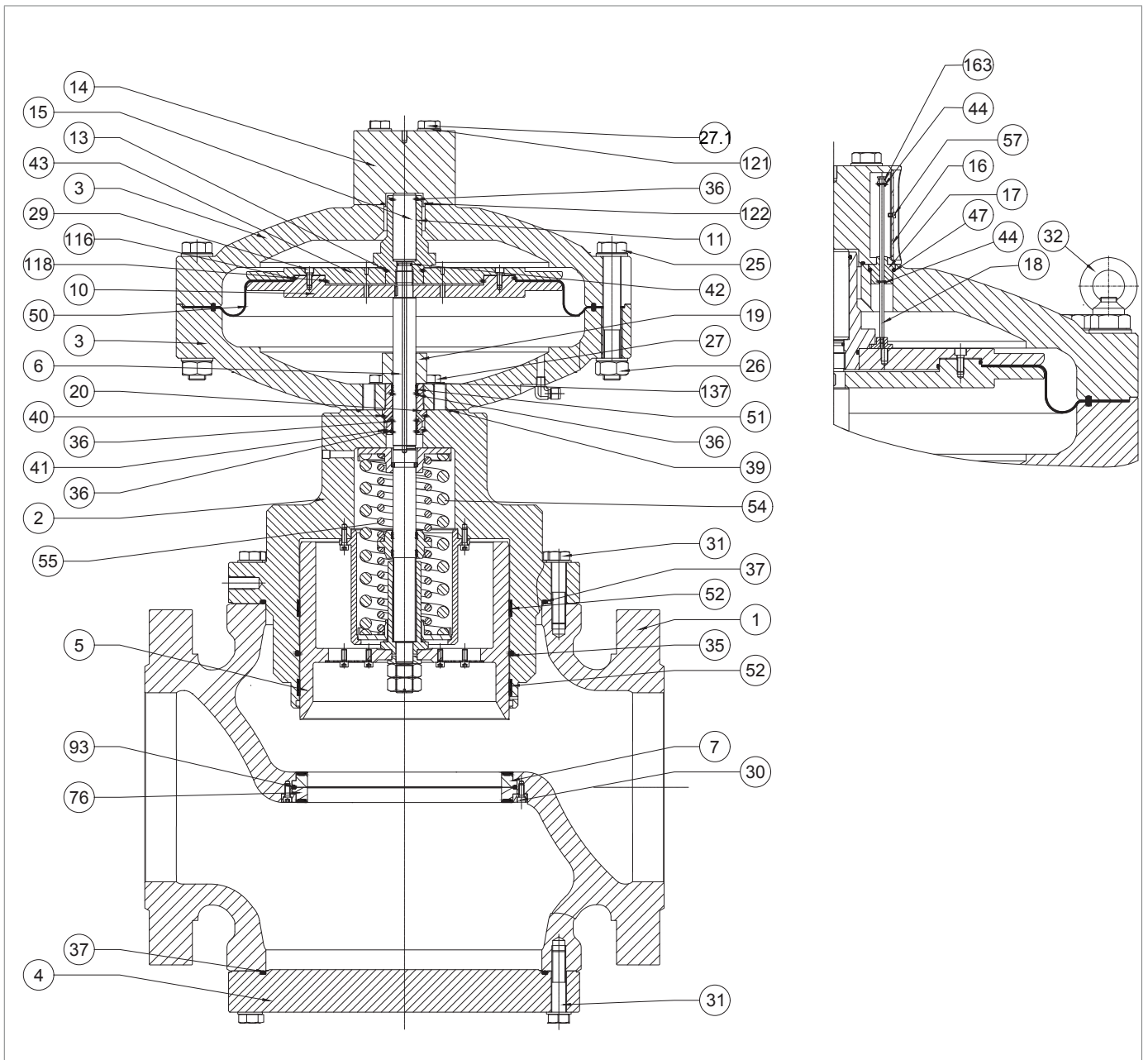







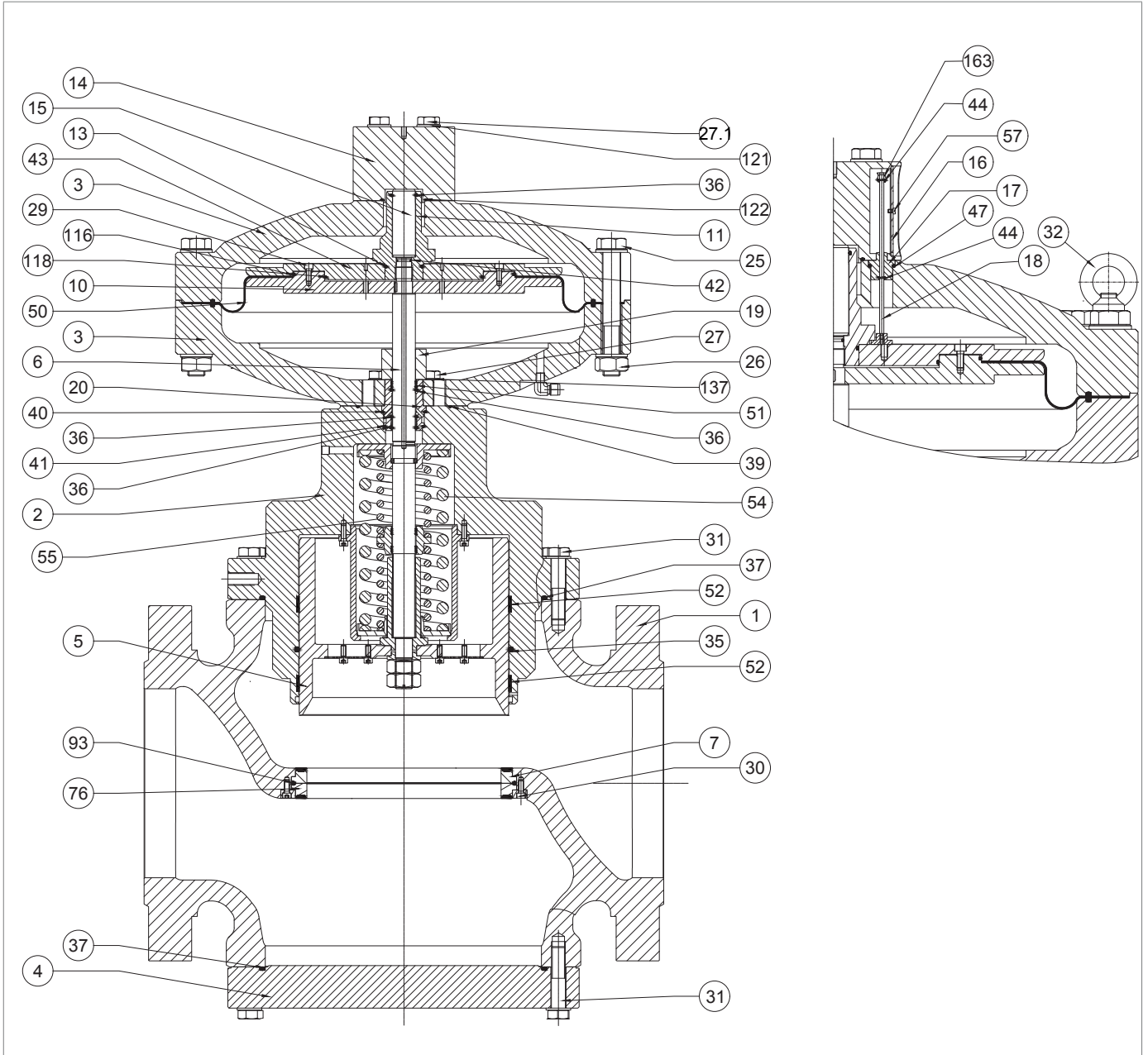

Fig. 9.59. Regulator REFLUX 819/FO 12"









Step	Action
1	Unscrew and remove the screws (57) from the eyebolt flange (14).
2	Remove the indicator slide (16).
3	Remove the pawl (163).
4	Remove and replace the O-ring (44) from the pawl (163), lubricating it with synthetic grease. <div style="border: 1px solid blue; padding: 5px;">  <b>NOTICE!</b>  <b>Before inserting the replacement O-ring, clean the retaining slots with a cleaning solution.</b> </div>
5	Unscrew and remove the screws (27.1) together with the washers (121) from the eyebolt flange (14).
6	Remove the eyebolt flange (14) from the top cover (3).
7	Remove and replace the O-ring (122) from the eyebolt flange (14), lubricating it with synthetic grease. <div style="border: 1px solid blue; padding: 5px;">  <b>NOTICE!</b>  <b>Before inserting the replacement O-ring, clean the retaining slots with a cleaning solution.</b> </div>
8	Pull the rod guide (17) out of the upper cover (3).
9	Remove the indicator rod (18).
10	Remove and replace the O-rings (44, 47) from the rod guide (17), lubricating them with synthetic grease. <div style="border: 1px solid blue; padding: 5px;">  <b>NOTICE!</b>  <b>Before inserting the replacement O-rings, clean the retaining slots with a cleaning solution.</b> </div>
11	Place the rod guide (17) in the upper cover (3).
12	Unscrew and remove the screws (31) securing the control head to the regulator body (1). <div style="border: 1px solid blue; padding: 5px;">  <b>NOTICE!</b>  <b>Support the head assembly during this step to avoid falls.</b> </div>
13	Remove the control head and place it on its side in a plane with an impact-resistant surface. <div style="border: 1px solid blue; padding: 5px;">  <b>NOTICE!</b>  <b>Take care not to damage the plug profile (5).</b> </div>
14	Remove the O-ring (37) from the plug guide (2) and replace it, lubricating it with synthetic grease. <div style="border: 1px solid blue; padding: 5px;">  <b>NOTICE!</b>  <b>Before inserting the replacement O-ring, clean the retaining slots with a cleaning solution.</b> </div>
15	Unscrew and remove the locknuts (33) together with the washer (23).
16	Remove the plug (5) from the plug guide (2) and place it on a table with an impact-resistant surface.
17	Remove and replace the I/DWR rings (52) from the plug guide (2). <div style="border: 1px solid blue; padding: 5px;">  <b>NOTICE!</b>  <b>Before inserting the replacement I/DWR rings, clean the retaining slots with a cleaning solution.</b> </div>



Step	Action
18	<p>Remove the O-ring (35) from the plug guide (2) and replace it, lubricating it with synthetic grease.</p> <p><b>! NOTICE!</b>  <b>Before inserting the replacement O-ring, clean the retaining slots with a cleaning solution.</b></p>
19	<p>Unscrew and remove the nuts (26) together with the screws (25) and the eyebolts (32).</p> <p><b>! NOTICE!</b>  <b>During this phase, the springs (54, 55) push the stem (6) upwards.</b></p>
20	<p>Remove the upper lid (3).</p>
21	<p>Unscrew and remove the balancing piston guide (11).</p> <p><b>! NOTICE!</b>  <b>In this step, keep the diaphragm unit still, fitting the compass wrench into the holes in the upper diaphragm support (13).</b></p>
22	<p>Remove the balancing piston (15) from the balancing piston guide (11).</p> <p><b>! NOTICE!</b>  <b>Take care not to damage the surface of the balancing plunger (15).</b></p>
23	<p>Remove the O-rings (36, 43) from the balancing piston guide (11) and replace them, lubricating them with synthetic grease.</p> <p><b>! NOTICE!</b>  <b>Before inserting the replacement O-rings, clean the retaining slots with a cleaning solution.</b></p>
24	<p>Fit the balancing piston (15) from the balancing piston guide (11).</p> <p><b>! NOTICE!</b></p> <ul style="list-style-type: none"> <li>• <b>Clean and lubricate the surface of the balance plunger (15) before insertion</b></li> <li>• <b>Take care not to damage the surface of the balance plunger (15)</b></li> </ul>
25	<p>Take out the diaphragm unit (10, 13, 21, 29, 50, 116, 118).</p> <p><b>! NOTICE!</b>  <b>Take care not to lose the key (28).</b></p>
26	<p>Unscrew and remove the screws (29) from the upper diaphragm holder (13).</p>
27	<p>Remove the upper membrane support (13).</p>
28	<p>Remove and replace the O-ring (118) from the upper diaphragm support (13), lubricating it with synthetic grease.</p> <p><b>! NOTICE!</b>  <b>Before inserting the replacement O-ring, clean the retaining slots with a cleaning solution.</b></p>
29	<p>Remove the diaphragm (50).</p>
30	<p>Remove and replace the O-ring (116) from the lower diaphragm support (10), lubricating it with synthetic grease.</p> <p><b>! NOTICE!</b>  <b>Before inserting the replacement O-ring, clean the retaining slots with a cleaning solution.</b></p>



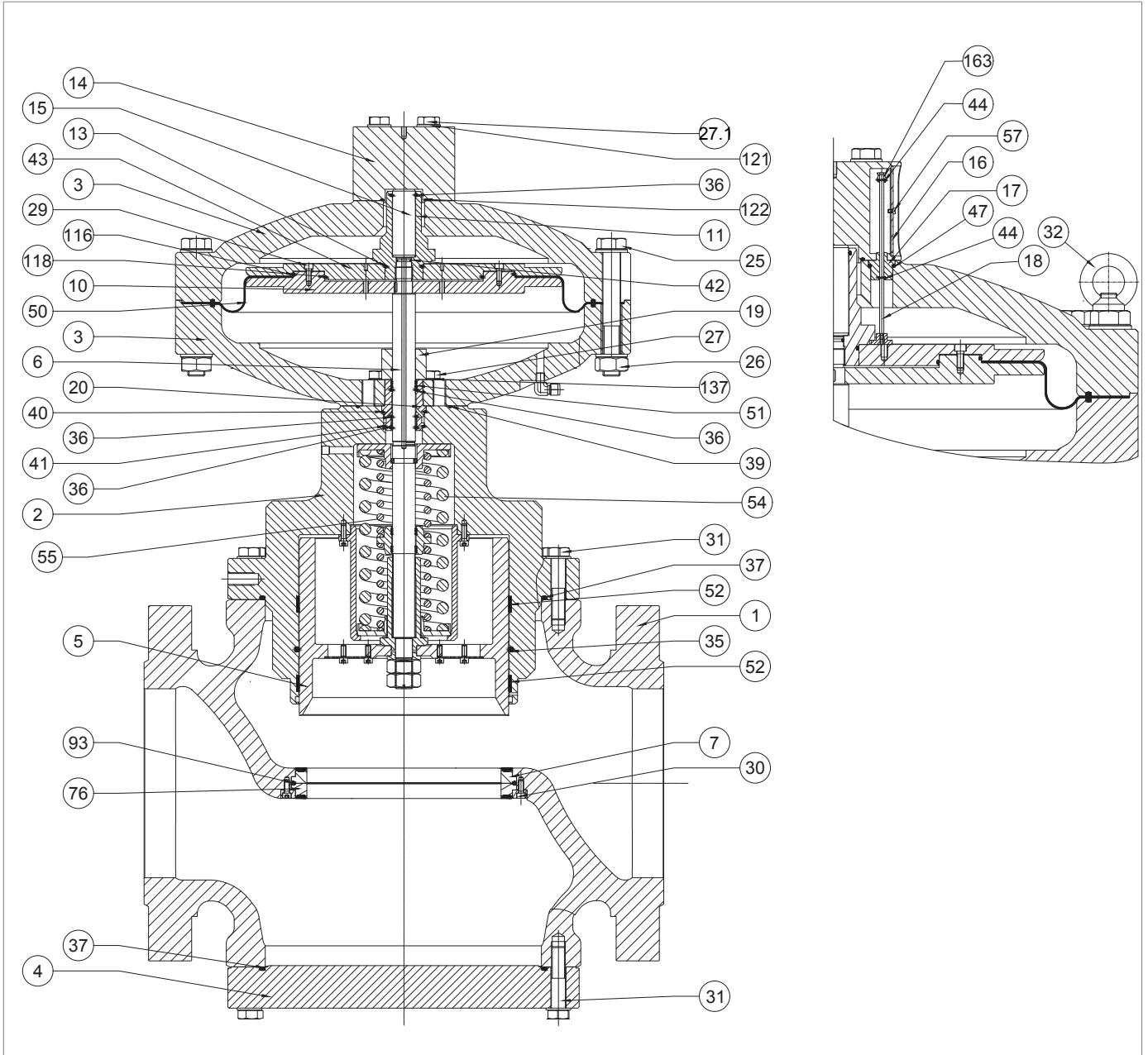

Regulator REFLUX 819/FO 12"

Step	Action
31	Position the replacement diaphragm (50). <div style="border: 1px solid black; padding: 5px;">  <b>NOTICE!</b>  <b>The concave part of the diaphragm must face the closing pressure chamber (pos. B, fig. 4.2).</b> </div>
32	Apply thread locking glue to insert and fix the screws (29) according to the following tightening torque: <ul style="list-style-type: none"> <li>• 12": Tab. 9.89</li> </ul> <div style="border: 1px solid black; padding: 5px;">  <b>NOTICE!</b>  <b>Tighten the screws according to the cross diagram in paragraph 9.4.2.2.</b> </div>
33	Remove the spacer (19).
34	Unscrew and remove the screws (27) together with the serrated washers (137) from the lower cover (3).
35	Remove the lower cover (3).
36	Remove the O-ring (39) from the plug guide (2) and replace it, lubricating it with synthetic grease. <div style="border: 1px solid black; padding: 5px;">  <b>NOTICE!</b>  <b>Before inserting the replacement O-ring, clean the retaining slots with a cleaning solution.</b> </div>
37	Remove stem guide (20).
38	Remove and replace the I/DWR rings (51) from the stem guide (20). <div style="border: 1px solid black; padding: 5px;">  <b>NOTICE!</b>  <b>Before inserting the replacement I/DWR rings, clean the retaining slots with a cleaning solution.</b> </div>
39	Remove and replace the O-ring (36) from the stem guide (20), lubricating it with silicone grease. <div style="border: 1px solid black; padding: 5px;">  <b>NOTICE!</b>  <b>Before inserting the replacement O-ring, clean the retaining slots with a cleaning solution.</b> </div>
40	Remove the O-rings (40, 41) from the stem guide (20) and replace them, lubricating them with synthetic grease. <div style="border: 1px solid black; padding: 5px;">  <b>NOTICE!</b>  <b>Before inserting the replacement O-rings, clean the retaining slots with a cleaning solution.</b> </div>
41	Remove the O-ring (42) from the stem (6) and replace it, lubricating it with synthetic grease. <div style="border: 1px solid black; padding: 5px;">  <b>NOTICE!</b>  <b>Before inserting the replacement O-ring, clean the retaining slots with a cleaning solution.</b> </div>
42	Position the stem guide (20). <div style="border: 1px solid black; padding: 5px;">  <b>NOTICE!</b>  <ul style="list-style-type: none"> <li>• <b>Lubricate the stem surface (6) with silicone grease</b></li> <li>• <b>The key (28) must be in the correct position in the stem (6)</b></li> </ul> </div>



Regulator REFLUX 819/FO 12"

Step	Action
43	Put the lower cover (3) in place and fix it on the plug guide (2).  <b>NOTICE!</b> <b>The hole for the passage of the loading pressure must match the similar one on the plug guide.</b>
44	Insert and secure the screws (27) together with the washers (137) in the lower cover (3), according to the tightening torque: <ul style="list-style-type: none"> <li>12": Tab. 9.89</li> </ul>  <b>NOTICE!</b> <b>Tighten the screws according to the cross diagram in paragraph 9.4.2.2.</b>
45	Put the diaphragm unit in place (10, 13, 21, 29, 50, 116, 118).  <b>NOTICE!</b> <b>Take care not to lose the key (28).</b>
46	Insert and secure the balancing stem guide (11) according to the tightening torque: <ul style="list-style-type: none"> <li>12": Tab. 9.89</li> </ul>  <b>NOTICE!</b> <b>Hold the diaphragm assembly in place and position the spanner in the holes in the upper diaphragm support (13).</b>
47	Fit the upper cover (3).
48	Insert and fasten the screws (25) with the nuts (26) according to the tightening torque: <ul style="list-style-type: none"> <li>12": Tab. 9.89</li> </ul>  <b>NOTICE!</b> <ul style="list-style-type: none"> <li><b>Tighten the screws according to the cross diagram in paragraph 9.4.2.2</b></li> <li><b>During this phase, the springs (54, 55) push the stem (6) upwards</b></li> </ul>
49	Insert the plug (5) into the plug guide (2).  <b>NOTICE!</b> <b>Before inserting the plug (5), clean and lubricate the surface with silicone grease.</b>
50	Insert the washer (23).
51	Insert and secure the locking nuts (33), applying threadlocking glue, according to the tightening torque: <ul style="list-style-type: none"> <li>12": Tab. 9.89</li> </ul>
52	Unscrew and remove the lower screws (31) from the blind flange (4) or any accessories.  <b>NOTICE!</b> <b>During this step, take care to support the flange (4) or any accessory.</b>
53	Remove the blind flange (4) or any accessories.  <b>NOTICE!</b> <b>During this step, take care to support the flange (4) or any accessory.</b>

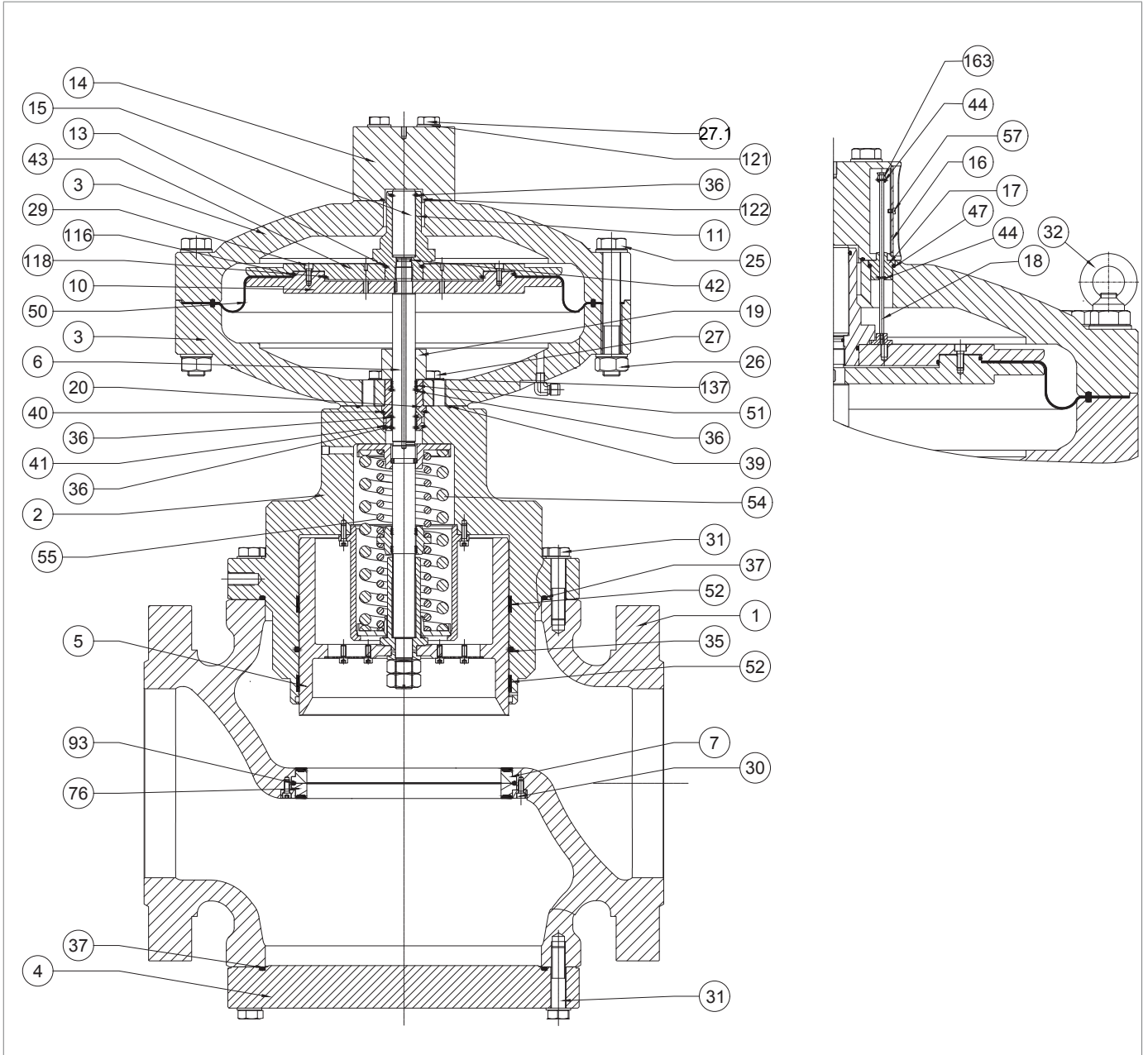



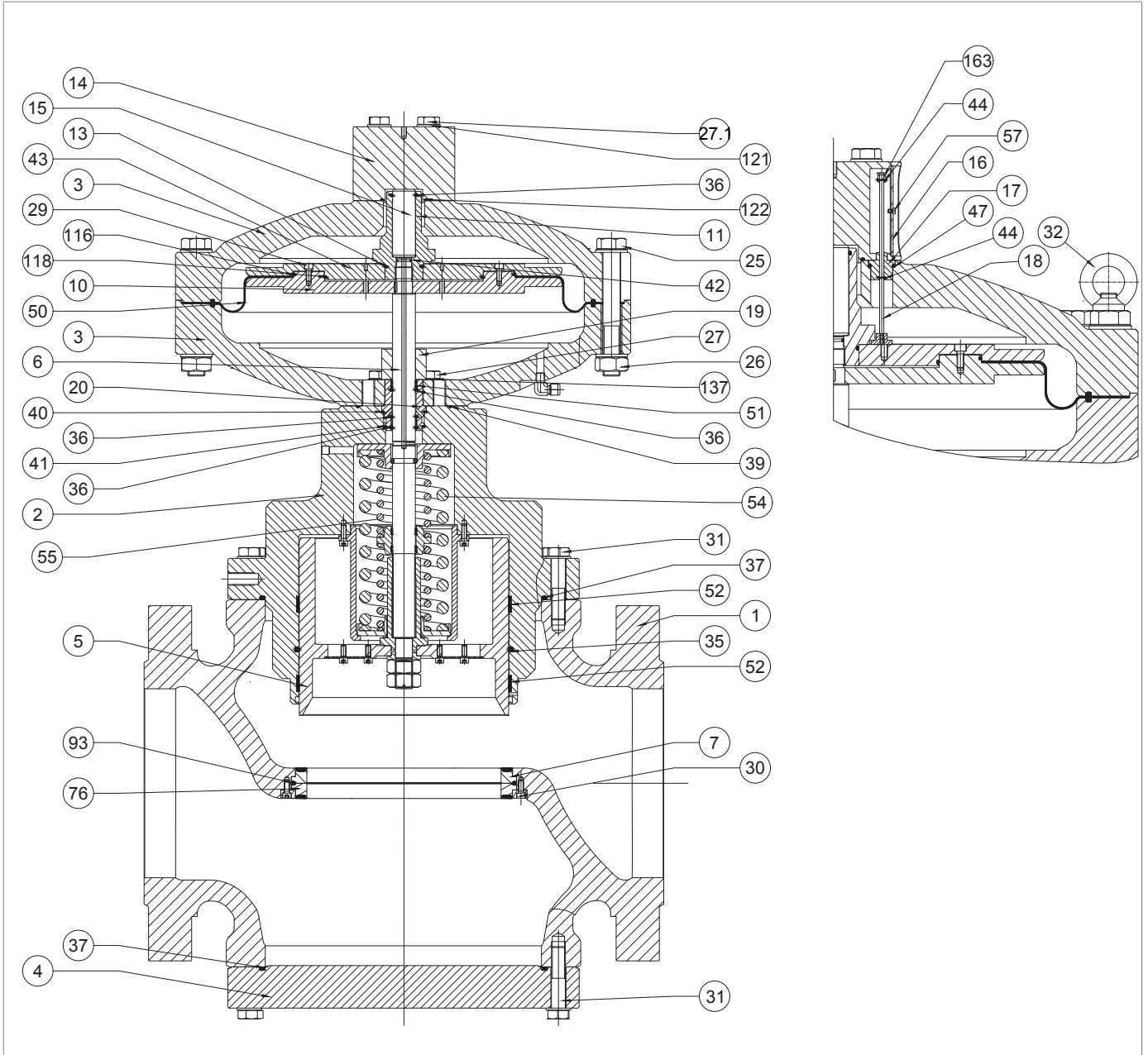

Regulator REFLUX 819/FO 12"

Step	Action
54	<p>Remove the O-ring (37) from the blind flange (4) and replace it, lubricating it with synthetic grease.</p> <p><b>! NOTICE!</b></p> <p><b>Before inserting the replacement O-ring, clean the retaining slots with a cleaning solution.</b></p>
55	<p>Unscrew and remove screws (30), shaft collar (8), reinforced gaskets (7, 76) and O-ring (93).</p> <p><b>! NOTICE!</b></p> <p><b>Take care that the upper seal does not fall off.</b></p>
56	<p>Remove and replace the O-ring (93) from the reinforced gaskets (7, 76), lubricating it with synthetic grease.</p> <p><b>! NOTICE!</b></p> <p><b>Before inserting the replacement O-ring, clean the retaining slots with a cleaning solution.</b></p>
57	<p>Clean the upper and lower supporting surfaces of the body, the flanges, the contact surfaces between the reinforced gasket (7) and the regulator body (1), and between the reinforced gasket (76) and the body (1).</p>
58	<p>Position the reinforced gaskets (7, 76) and the shaft collar (8).</p>
59	<p>Insert and fix the screws (30) according to the following tightening torque:</p> <ul style="list-style-type: none"> <li>• 12": Tab. 9.89</li> </ul> <p><b>! NOTICE!</b></p> <p><b>Tighten the screws according to the cross diagram in paragraph 9.4.2.2.</b></p>
60	<p>Fit the blind flange (4) or any accessory.</p> <p><b>! NOTICE!</b></p> <p><b>During this step, take care to support the flange (4) or any accessory.</b></p>
61	<p>Insert and fasten the lower screws (31) in the blind flange (4) according to the tightening torque:</p> <ul style="list-style-type: none"> <li>• 12": Tab. 9.89</li> </ul> <p><b>! NOTICE!</b></p> <p><b>Tighten the screws according to the cross diagram in paragraph 9.4.2.2.</b></p>
62	<p>Position the control head inside the regulator body (1).</p> <p><b>! NOTICE!</b></p> <p><b>Take care not to damage the plug profile (5).</b></p>
63	<p>Insert and fasten the upper screws (31) that secure the control head to the regulator body (1), according to the tightening torque:</p> <ul style="list-style-type: none"> <li>• 12": Tab. 9.89</li> </ul> <p><b>! NOTICE!</b></p> <p><b>Tighten the screws according to the cross diagram in paragraph 9.4.2.2.</b></p>
64	<p>Insert the indicator rod (18) into the upper cover (3).</p> <p><b>! NOTICE!</b></p> <p><b>Hook the indicator rod (18) between the balancing piston guide (11) and the upper diaphragm holder (13).</b></p>



Regulator REFLUX 819/FO 12"

Step	Action
65	Insert the indicator rod guide (17) into the indicator rod (18).  <b>NOTICE!</b> <b>Position the indicator rod guide (17) in the hole in the top cover (3).</b>
66	Position the eyebolt flange (14) with the upper lid (3).  <b>NOTICE!</b> <b>The eyebolt flange stroke indicator (14) must be perpendicular to the gas flow and visible.</b>
67	Insert and secure the screws (27.1) together with the washers (121) in the upper cover (3), according to the tightening torque: <ul style="list-style-type: none"> <li>• 12": Tab. 9.89</li> </ul>  <b>NOTICE!</b> <b>Tighten the screws according to the cross diagram in paragraph 9.4.2.2.</b>
68	Insert the pawl (163) into the indicator rod (18).
69	Place the indicator slide (16) in the eyebolt flange (14).  <b>NOTICE!</b> <b>Check that the pawl (163) is in position 100% in relation to the indicator slide (16).</b>
70	Insert and fasten the screws (57).

Tab. 9.131

 **WARNING!**

**Ensure that all parts have been fitted correctly.**

9.4.4 - DB/819 SILENCER MAINTENANCE PROCEDURE

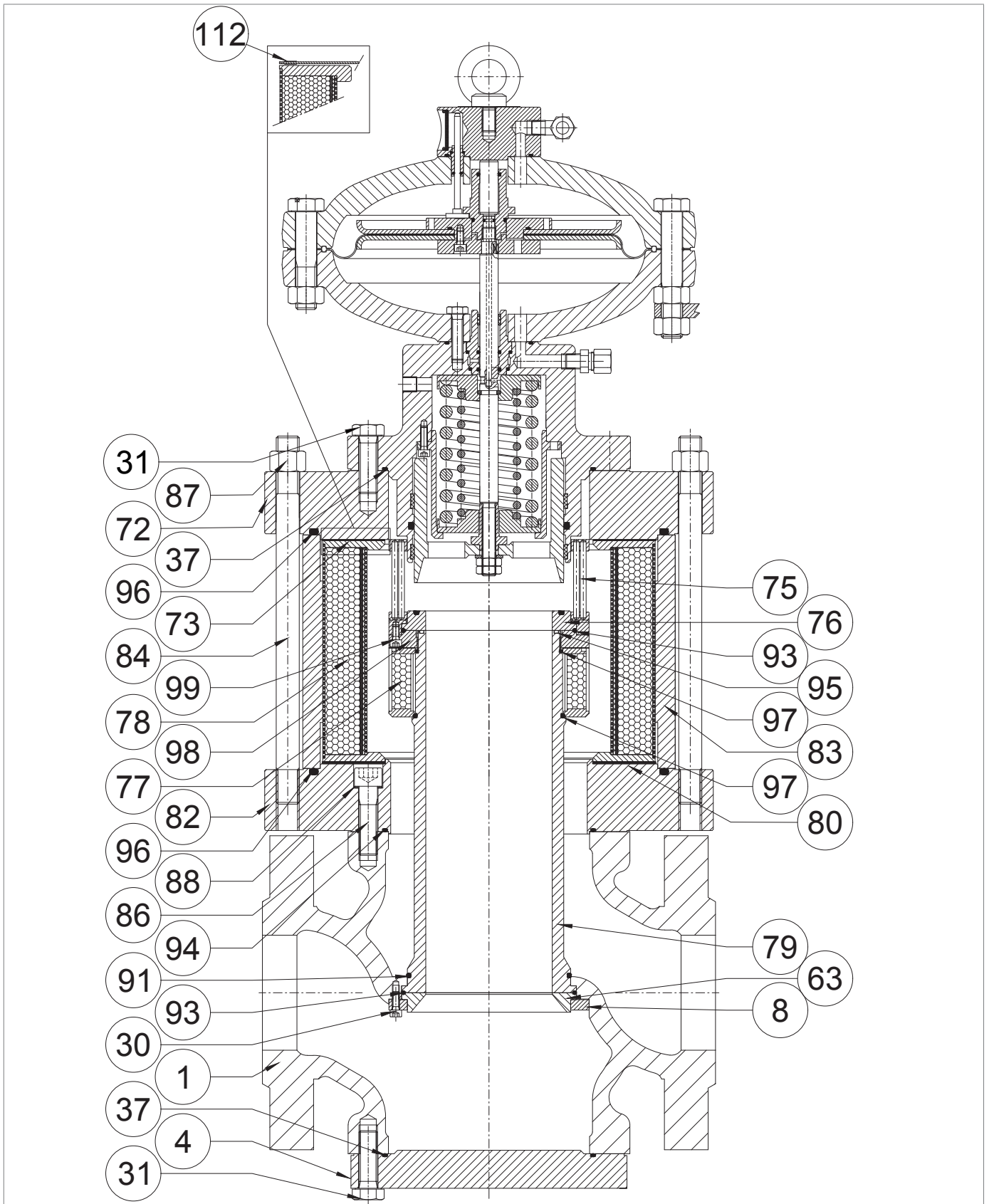
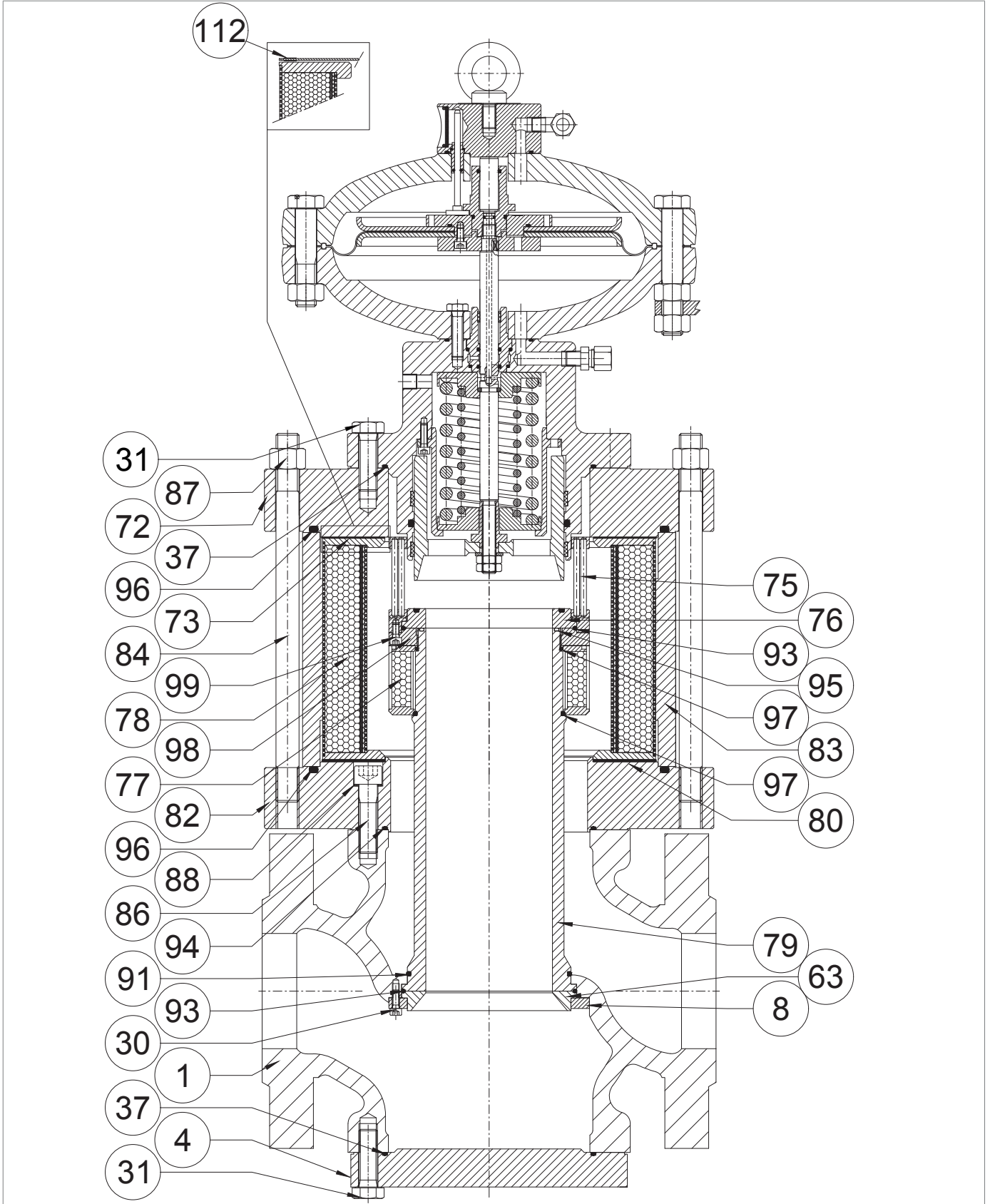

Fig. 9.60. DB/819 silencer

Step	Action
1	<p>Unscrew and remove the screws (31) that secure the control head to the upper flange (72) of the silencer.</p> <p><b>! NOTICE!</b></p> <p><b>Support the head assembly during this step to avoid falls.</b></p>
2	<p>Remove the control head and place it on its side in a plane with an impact-resistant surface.</p> <p><b>! NOTICE!</b></p> <p><b>Take care not to damage the plug profile (5).</b></p>
3	<p>Remove the O-ring (37) from the plug guide (2) and replace it, lubricating it with synthetic grease.</p> <p><b>! NOTICE!</b></p> <p><b>Before inserting the replacement O-ring, clean the retaining slots with a cleaning solution.</b></p>
4	<p>Unscrew and remove the grid assembly (76, 93, 98, 99).</p> <p><b>! NOTICE!</b></p> <p><b>To do so, use tool ref.O, tab.48 of paragraph 7.1 "List of equipment".</b></p>
5	Unscrew and remove the nuts (87).
6	Remove the upper flange (72).
7	<p>Remove the O-ring (96) from the upper flange (72) and replace it, lubricating it with synthetic grease.</p> <p><b>! NOTICE!</b></p> <p><b>Before inserting the replacement O-ring, clean the retaining slots with a cleaning solution.</b></p>
8	Remove the upper anti-oil gasket (73).
9	Remove the external basket (78).
10	Remove the plating (83).
11	Remove the internal basket (77).
12	<p>Remove the O-ring (95) from the sleeve (79) and replace it, lubricating it with synthetic grease.</p> <p><b>! NOTICE!</b></p> <p><b>Before inserting the replacement O-ring, clean the retaining slots with a cleaning solution.</b></p>
13	Remove and replace the lower anti-oil gasket (80).
14	<p>Remove the O-ring (96) from the lower flange (82) and replace it, lubricating it with synthetic grease.</p> <p><b>! NOTICE!</b></p> <p><b>Before inserting the replacement O-ring, clean the retaining slots with a cleaning solution.</b></p>
15	<p><b>a- ONLY VALID FOR 1"- 8"</b> Undo and remove the screws (86) and the washers (88).</p> <p><b>b- ONLY VALID FOR 10", 12"</b> Undo and remove the screws (86).</p>
16	Remove the lower flange (82) together with the tie rods (84).



DB/819 silencer

REFLUX 819/FO

Step	Action
17	<p><b>a- ONLY VALID FOR 1" ÷ 8"</b> Remove the O-ring (94) from the lower flange (82) and replace it, lubricating it with synthetic grease.</p> <p><b>! NOTICE!</b> <b>Before inserting the replacement O-ring, clean the retaining slots with a cleaning solution.</b></p>
	<p><b>b- APPLICABLE TO 10" ONLY</b> Remove the O-ring (92, 94) from the lower flange (82) and replace it, lubricating it with synthetic grease.</p> <p><b>! NOTICE!</b> <b>Before inserting the replacement O-ring, clean the retaining slots with a cleaning solution.</b></p>
	<p><b>c- ONLY VALID FOR 12"</b> Remove the O-ring (92) from the lower flange (82) and replace it, lubricating it with synthetic grease.</p> <p><b>! NOTICE!</b> <b>Before inserting the replacement O-ring, clean the retaining slots with a cleaning solution.</b></p>
18	<p><b>! WARNING!</b> <b>Support the flange or any accessory to prevent it from falling</b></p>
19	Undo and remove the screws (64).
20	Remove the blind flange (4) or any built-in accessory (monitor PM/819 or built-in slam-shut valve SB/82 or HB/97).
21	Remove the O-ring (37) from the blind flange (4) and replace it, lubricating it with synthetic grease.
	<p><b>! NOTICE!</b> <b>Before inserting the replacement O-ring, clean the retaining slots with a cleaning solution.</b></p>
22	<p><b>! WARNING!</b> <b>Support the sleeve (79) during the next steps to prevent it from falling.</b></p>
23	Undo and remove the screws (30), the shaft collar (8) and the conical seat (63).
	<p><b>! NOTICE!</b> <b>As an alternative to the conical seat (63), a reinforced gasket may be installed, based on the built-in accessory.</b></p>
24	Remove the sleeve (79) from the top downwards.
25	Remove the O-ring (91, 97) from the sleeve (79) and replace it, lubricating it with synthetic grease.
	<p><b>! NOTICE!</b> <b>Before inserting the replacement O-ring, clean the retaining slots with a cleaning solution.</b></p>

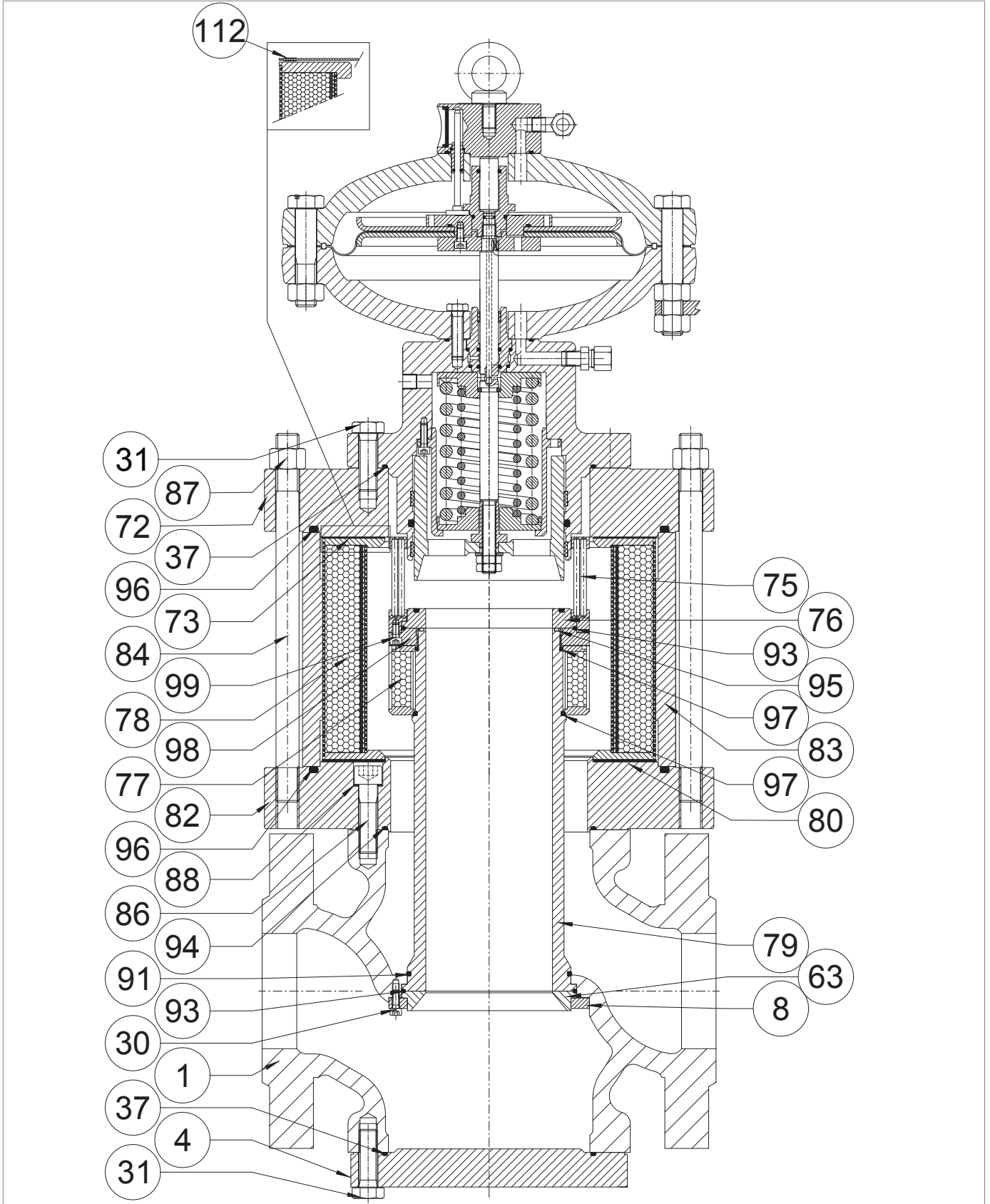

DB/819 silencer

REFLUX 819/FO

Step	Action
26	<p>Remove the O-ring (93) from the conical seat (63) and replace it, lubricating it with synthetic grease.</p> <div style="border: 1px solid black; padding: 5px;"> <p><b>! NOTICE!</b>  <b>Before inserting the replacement O-ring, clean the retaining slots with a cleaning solution.</b></p> </div>
27	<p>Clean the upper and lower bearing surfaces of the body (1) and the flanges (72, 82), the contact surfaces between the sleeve (79), conical seat (63) and the body.</p>
28	<p>Put the sleeve (79) back in place into the body from the bottom upwards.</p>
29	<p>Put the conical seat (63) back in place together with the O-ring (93) and the shaft collar (8).</p> <div style="border: 1px solid black; padding: 5px;"> <p><b>! NOTICE!</b>  <b>As an alternative to the conical seat (63), a reinforced gasket may be installed, based on the built-in accessory.</b></p> </div>
30	<p>Insert and fix the screws (30) according to the following tightening torques:</p> <ul style="list-style-type: none"> <li>• 1": Tab. 9.90</li> <li>• 2": Tab. 9.91</li> <li>• 3": Tab. 9.92</li> <li>• 4": Tab. 9.93</li> <li>• 6": Tab. 9.94</li> <li>• 8": Tab. 9.95</li> <li>• 10": Tab. 9.96</li> <li>• 12": Tab. 9.97</li> </ul> <div style="border: 1px solid black; padding: 5px;"> <p><b>! NOTICE!</b>  <b>Tighten the screws according to the cross diagram in paragraph 9.4.2.2.</b></p> </div>
31	<p><b>! WARNING!</b>  <b>Support the flange or any accessory to prevent it from falling</b></p>
32	<p>Position the blind flange (4) or any built-in accessory (monitor PM/819 or built-in slam-shut valve SB/82, HB/97).</p>
33	<p>Insert and fasten the screws (64) in the blank flange (4) according to the tightening torques:</p> <ul style="list-style-type: none"> <li>• 1": Tab. 9.90</li> <li>• 2": Tab. 9.91</li> <li>• 3": Tab. 9.92</li> <li>• 4": Tab. 9.93</li> <li>• 6": Tab. 9.94</li> <li>• 8": Tab. 9.95</li> <li>• 10": Tab. 9.96</li> <li>• 12": Tab. 9.97</li> </ul> <div style="border: 1px solid black; padding: 5px;"> <p><b>! NOTICE!</b>  <b>Tighten the screws according to the cross diagram in paragraph 9.4.2.2.</b></p> </div>
34	<p>Fit the lower flange (82) together with the tie rods (84).</p>
35	<p><b>ONLY VALID FOR 1" ÷ 8"</b>          Replace the washers (88).</p>
36	<p>Insert and fix the screws (86) according to the following tightening torques:</p> <ul style="list-style-type: none"> <li>• 1": Tab. 9.90</li> <li>• 2": Tab. 9.91</li> <li>• 3": Tab. 9.92</li> <li>• 4": Tab. 9.93</li> <li>• 6": Tab. 9.94</li> <li>• 8": Tab. 9.95</li> <li>• 10": Tab. 9.96</li> <li>• 12": Tab. 9.97</li> </ul> <div style="border: 1px solid black; padding: 5px;"> <p><b>! NOTICE!</b>  <b>Tighten the screws according to the cross diagram in paragraph 9.4.2.2.</b></p> </div>

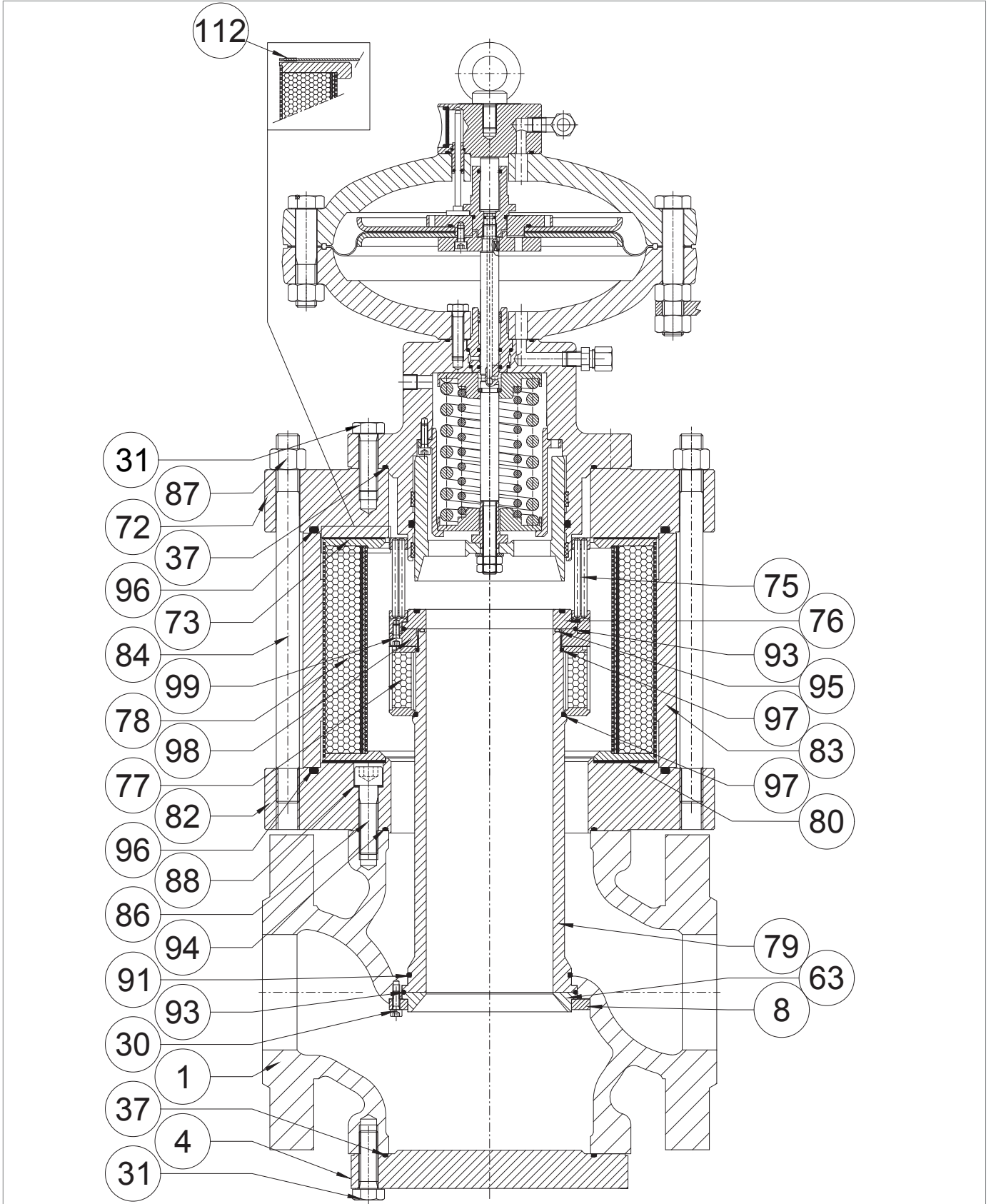

DB/819 silencer

REFLUX 819/FO

Step	Action
37	Position the replacement lower oil seal (80).
38	Fit the plating (83).
39	Fit the external basket (78).
40	Fit the internal basket (77).
41	Position the replacement upper oil seal (73).
42	Fit the upper flange (72).
43	<p>Insert and fix the nuts (87) according to the following tightening torques:</p> <ul style="list-style-type: none"> <li>• 1": Tab. 9.90</li> <li>• 2": Tab. 9.91</li> <li>• 3": Tab. 9.92</li> <li>• 4": Tab. 9.93</li> <li>• 6": Tab. 9.94</li> <li>• 8": Tab. 9.95</li> <li>• 10": Tab. 9.96</li> <li>• 12": Tab. 9.97</li> </ul>
	<p><b>NOTICE!</b></p> <p><b>Tighten the screws according to the cross diagram in paragraph 9.4.2.2.</b></p>
44	Unscrew and remove the screws (99).
45	Remove the shaft collar nut (98).
46	<p>Remove the O-ring (93) and replace it, taking care to lubricate it with synthetic grease.</p> <p><b>NOTICE!</b></p> <p><b>Before inserting the replacement O-ring, clean the retaining slots with a cleaning solution.</b></p>
47	<p>Remove and replace the reinforced gasket (76).</p> <p><b>NOTICE!</b></p> <p><b>Before inserting the replacement reinforced gasket, clean the retaining grooves with a cleaning solution.</b></p>
48	Position the shaft collar nut (98).
49	Insert and fasten the screws (99).
50	<p>Insert and secure the grid assembly (76, 93, 98, 99) to the sleeve (79).</p> <p><b>NOTICE!</b></p> <p><b>To do so, use tool ref.O, tab.7.62 of paragraph 7.1 "List of equipment".</b></p>
51	Position control header.
52	<p>Insert and fasten the nuts (31) that secure the control head to the upper flange (72) of the silencer, according to the tightening torques:</p> <ul style="list-style-type: none"> <li>• 1": Tab. 9.90</li> <li>• 2": Tab. 9.91</li> <li>• 3": Tab. 9.92</li> <li>• 4": Tab. 9.93</li> <li>• 6": Tab. 9.94</li> <li>• 8": Tab. 9.95</li> <li>• 10": Tab. 9.96</li> <li>• 12": Tab. 9.97</li> </ul>
	<p><b>NOTICE!</b></p> <p><b>Tighten the screws according to the cross diagram in paragraph 9.4.2.2.</b></p>

Tab. 9.132

**WARNING!**

Ensure that all parts have been fitted correctly.

**9.4.5 - PM/819 BUILT-IN MONITOR MAINTENANCE PROCEDURE**

**9.4.5.1 - BUILT-IN MONITOR PM/819 1"÷ 2"**

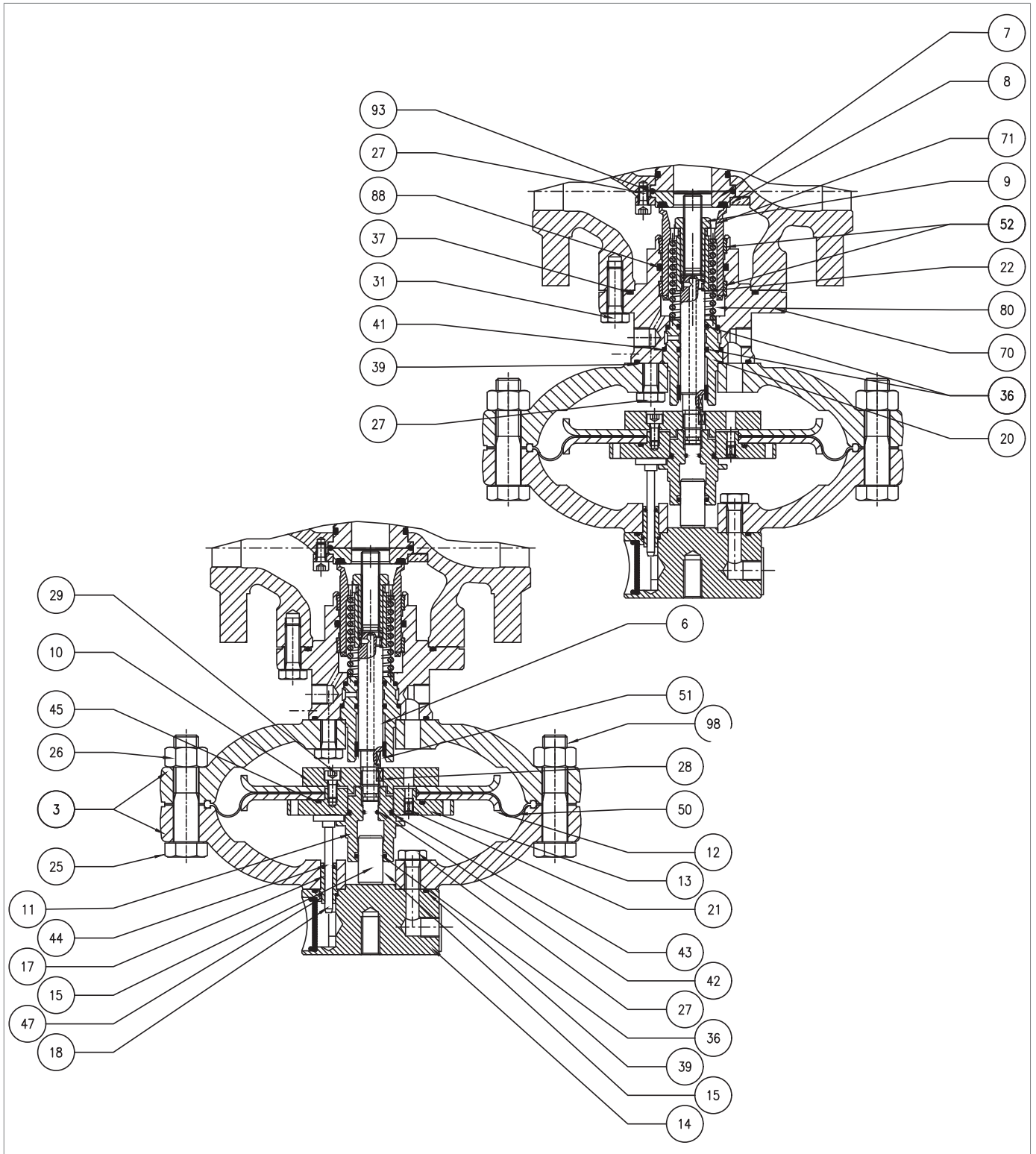
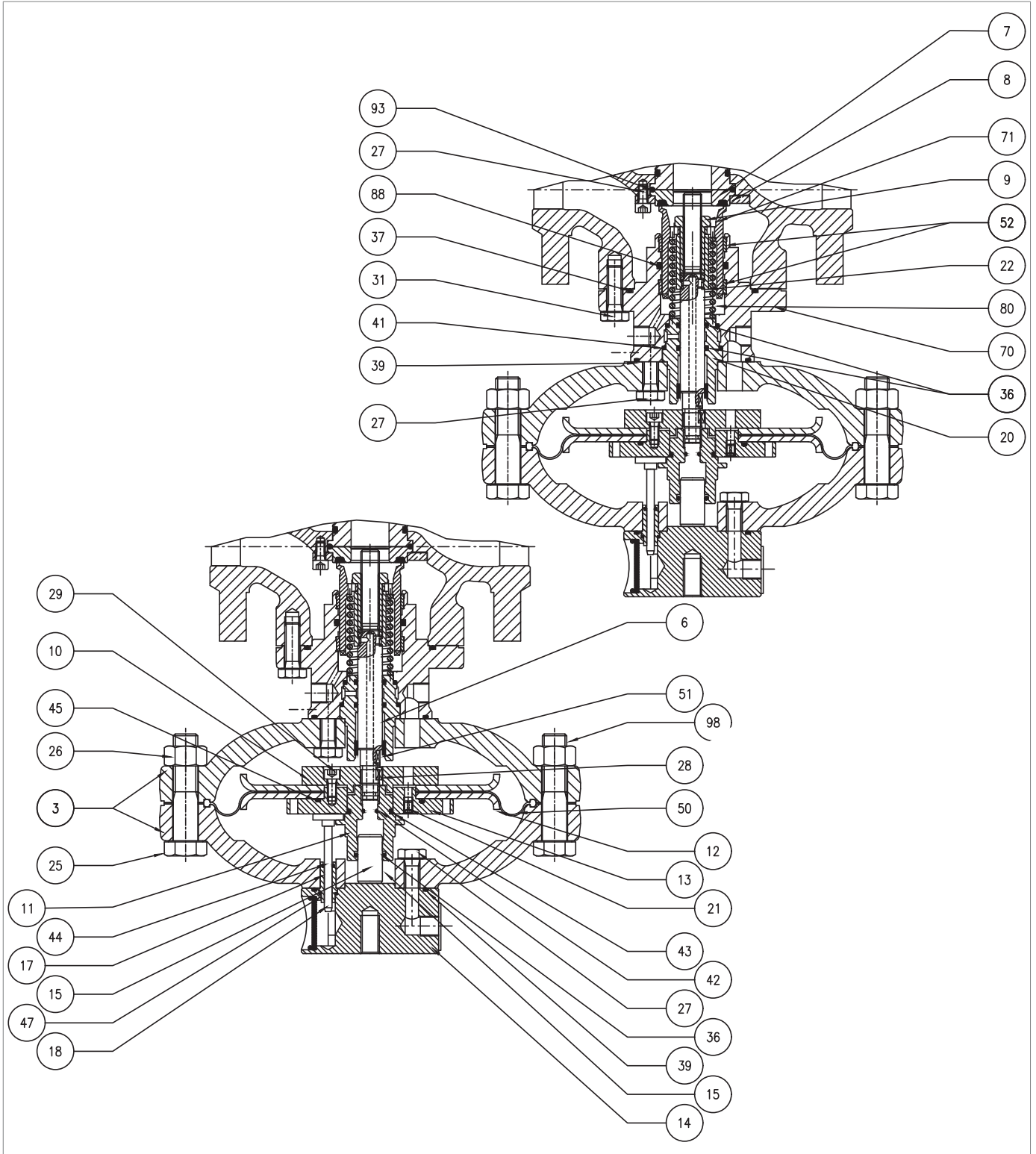

Fig. 9.61. Built-in monitor PM/819 1"÷ 2"

Step	Action
1	Undo and remove the screws (31). <b>NOTICE!</b> <b>Support the head assembly during this step to avoid falls.</b>
2	Remove the reduction unit and place it on its side, on an anti-shock surface. <b>NOTICE!</b> <b>Take care not to damage the plug profile (71).</b>
3	Remove the O-ring (37) from the plug guide (70) and replace it, lubricating it with synthetic grease. <b>NOTICE!</b> <b>Before inserting the replacement O-ring, clean the retaining slots with a cleaning solution.</b>
4	Undo and remove the screws (30), the shaft collar (8), the reinforced gasket (7) and the O-ring (39), preventing them from falling. <b>NOTICE!</b> <b>Make sure that the sleeve does not fall (only for aperflux and app. with DB).</b>
5	Remove the O-ring (39) from the reinforced gasket (7) and replace it, lubricating it with synthetic grease. <b>NOTICE!</b> <b>Before inserting the replacement O-ring, clean the retaining slots with a cleaning solution.</b>
6	Position the reinforced gasket (7) and the shaft collar (8).
7	Insert and fix the screws (30) according to the following tightening torque: <ul style="list-style-type: none"> <li>1": Tab. 9.98</li> <li>2": Tab. 9.99</li> </ul> <b>NOTICE!</b> <b>Tighten the screws as shown in the diagram at "9.4.2.2 - Cross diagram for tightening screws".</b>
8	Unscrew the lock nut (9). <b>NOTICE!</b> <b>Take care not to damage the plug profile (71).</b>
9	Remove the plug (71) and place it on an anti-shock surface.
10	Remove the spring (80) and the spacer (22).
11	Remove and replace the I/DWR rings (52) from the plug guide (70). <b>NOTICE!</b> <b>Before inserting the replacement I/DWR rings, clean the retaining slots with a cleaning solution.</b>
12	Remove the O-ring (88) from the plug (70) and replace it, lubricating it with synthetic grease. <b>NOTICE!</b> <b>Before inserting the replacement O-ring, clean the retaining slots with a cleaning solution.</b>



Built-in monitor PM/819 1"÷ 2"

Step	Action
13	Clean the plug (71) and the plug guide (70) lubricating with silicone grease.
14	Unscrew and remove the nuts (26) together with the screws (25, 98).
15	Remove the upper lid (3).
16	Remove the indicator rod (18) from the rod guide (17).
17	Undo and remove the screws of the upper section (27).
18	Separate the upper cover (3) from the eyebolt flange (14).
19	Take out the rod guide (17).
20	Remove the O-rings (39, 47) from the eyebolt flange (14) and replace them, lubricating them with synthetic grease. <b>NOTICE!</b> <b>Before inserting the replacement O-ring, clean the retaining slots with a cleaning solution.</b>
21	Remove the O-ring (44) from the rod guide (17) and replace it, lubricating it with synthetic grease. <b>NOTICE!</b> <b>Before inserting the replacement O-ring, clean the retaining slots with a cleaning solution.</b>
22	Place the rod guide (17) in the eyebolt flange (14).
23	Assemble the eyebolt flange (14) with the upper lid (3).
24	Insert and fix the screws of the upper section (27) according to the following tightening torque: • 1": Tab. 9.98 • 2": Tab. 9.99 <b>NOTICE!</b> <b>Tighten the screws as shown in the diagram at "9.4.2.2 - Cross diagram for tightening screws".</b>
25	Insert the indicator rod (18) into the rod guide (17).
26	Unscrew and remove the piston guide (11). <b>NOTICE!</b> <b>In this step, keep the diaphragm unit still, fitting the compass wrench into the holes in the upper diaphragm support (13).</b>
27	Remove the balancing piston (15) from the piston guide (11).
28	Remove the O-rings (36, 43) from the eyebolt flange (11) and replace them, lubricating them with synthetic grease. <b>NOTICE!</b> <b>Before inserting the replacement O-rings, clean the retaining slots with a cleaning solution.</b>
29	Place the balancing piston (15) in the piston guide (11).
30	Take out the diaphragm unit.
31	Unscrew and remove the screws (29) from the lower diaphragm support (10).
32	Remove the diaphragm support (10) and the lower diaphragm protection disc (12).
33	Remove the diaphragm (50).
34	Remove the upper diaphragm support (13) from the lower diaphragm protection disc (12).

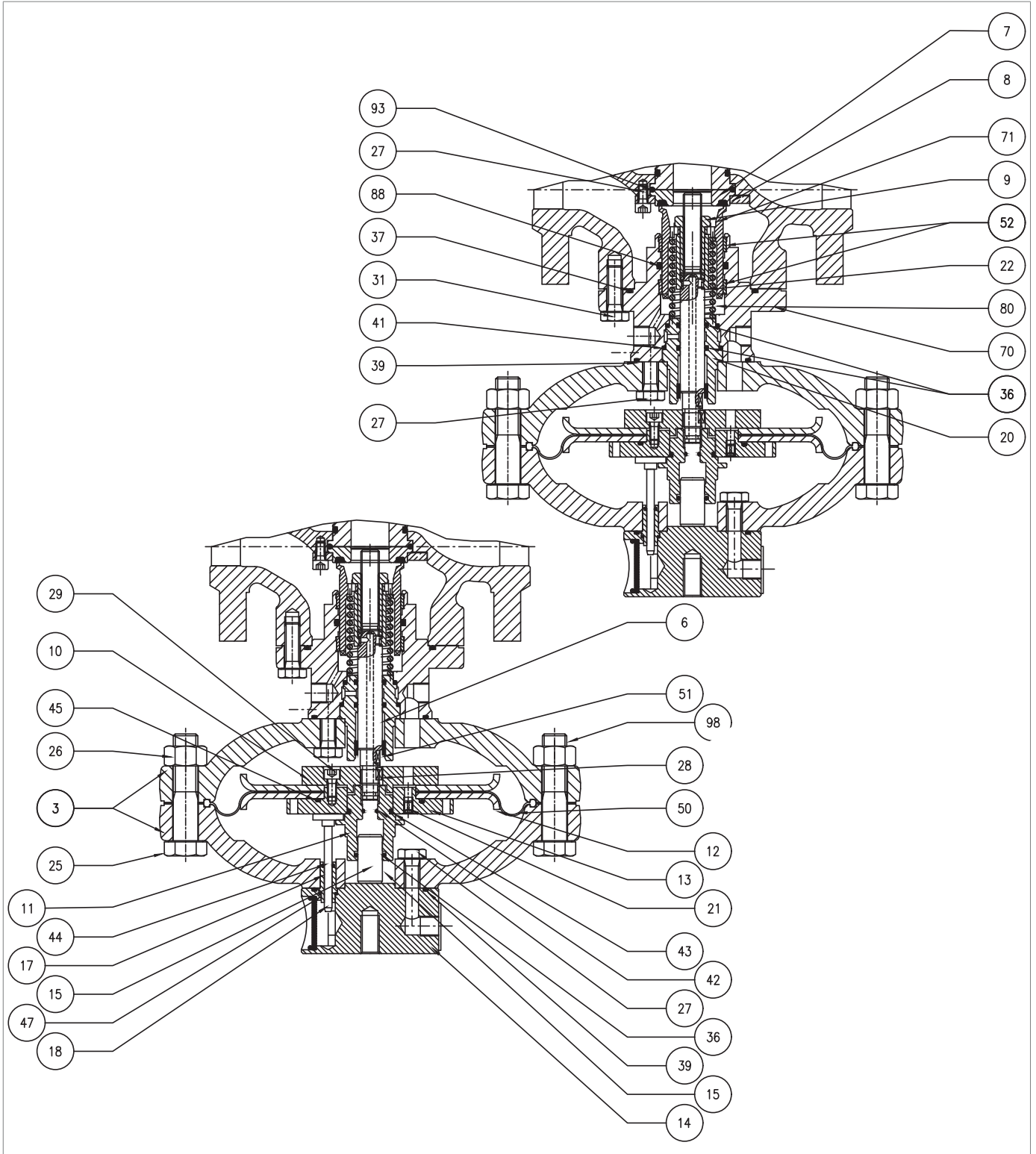

Built-in monitor PM/819 1"÷ 2"

Step	Action
35	<p>Remove and replace the O-ring (45) from the upper diaphragm support (13), lubricating it with synthetic grease.</p> <p><b>! NOTICE!</b> <b>Before inserting the replacement O-ring, clean the retaining slots with a cleaning solution.</b></p>
36	<p>Put the upper diaphragm support (13) back in place into the upper diaphragm protection disc (12).</p> <p><b>! NOTICE!</b> <b>Check that the transfer hole (21) is free of dirt or foreign bodies.</b></p>
37	<p>Fit the new diaphragm (50).</p> <p><b>! NOTICE!</b> <b>Fit the diaphragm so that its convulsion is oriented towards the loading chamber.</b></p>
38	<p>Put the diaphragm protection disc (12) and the lower diaphragm support (10) in place.</p> <p><b>! NOTICE!</b> <b>Check that the nozzle hole on the upper diaphragm support (13) is aligned with the hole on the lower diaphragm support (10).</b></p>
39	<p>Apply thread locking glue to insert and fix the screws (29) according to the following tightening torque:</p> <ul style="list-style-type: none"> <li>• 1": Tab. 9.98</li> <li>• 2": Tab. 9.99</li> </ul> <p><b>! NOTICE!</b> <b>Tighten the screws as shown in the diagram at "9.4.2.2 - Cross diagram for tightening screws".</b></p>
40	Undo and remove the screws of the lower section (27).
41	Remove the lower cover (3).
42	<p>Remove the O-ring (39) from the plug guide (70) and replace it, lubricating it with synthetic grease.</p> <p><b>! NOTICE!</b> <b>Before inserting the replacement O-ring, clean the retaining slots with a cleaning solution.</b></p>
43	Remove the stem guide (20), the stem (6) and the key (28).
44	<p>Remove and replace the I/DWR rings (51) from the stem guide (20).</p> <p><b>! NOTICE!</b> <b>Before inserting the replacement O-ring, clean the retaining slots with a cleaning solution.</b></p>
45	<p>Remove the O-rings (36) from the stem guide (20) and replace them, lubricating them with synthetic grease.</p> <p><b>! NOTICE!</b> <b>Before inserting the replacement O-ring, clean the retaining slots with a cleaning solution.</b></p>
46	<p>Remove the O-rings (40, 41) from the stem guide (20) and replace them, lubricating them with synthetic grease.</p> <p><b>! NOTICE!</b> <b>Before inserting the replacement O-rings, clean the retaining slots with a cleaning solution.</b></p>

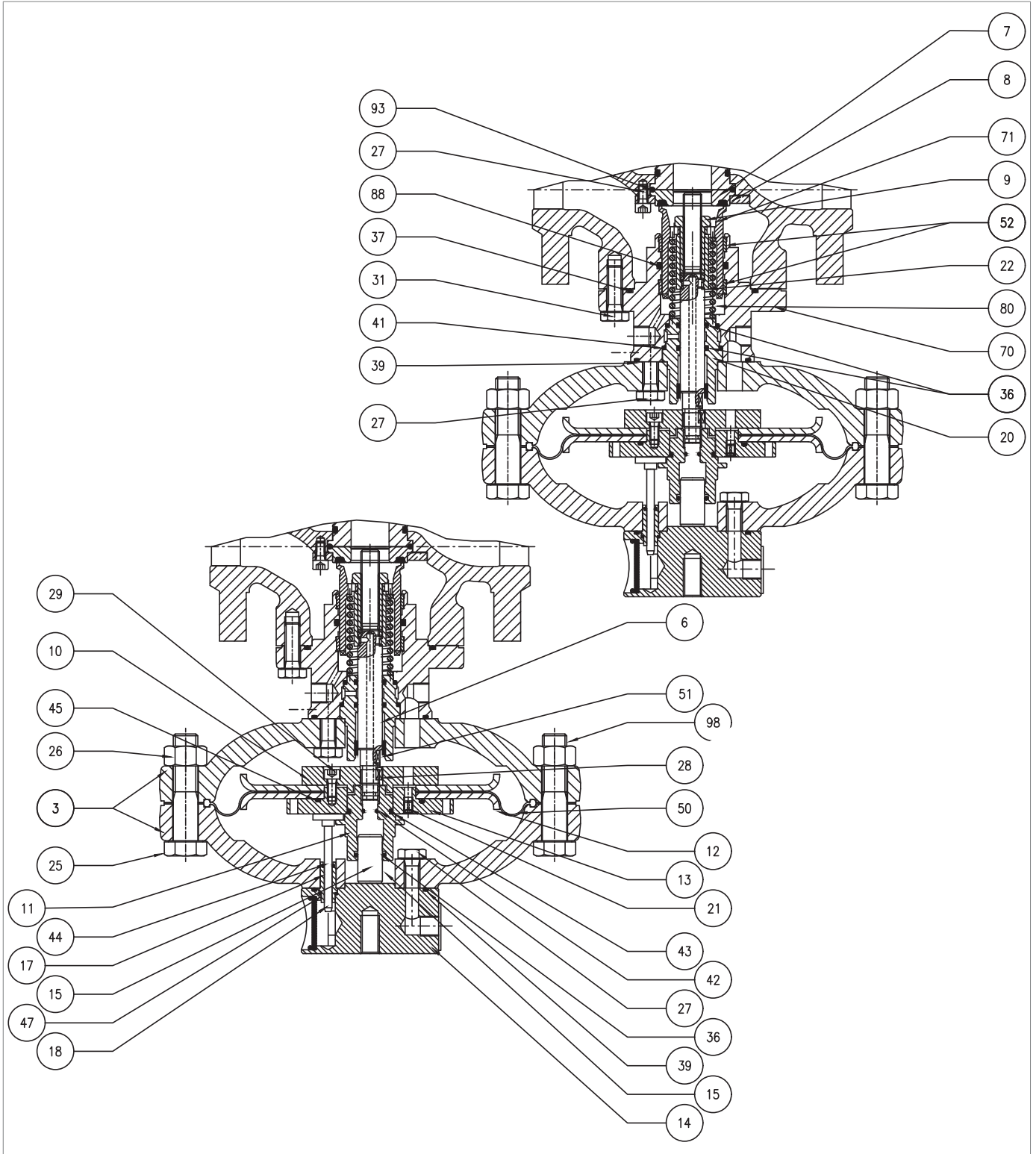

Built-in monitor PM/819 1"÷ 2"

Step	Action
47	<p>Remove the O-ring (42) from the stem (6) and replace it, lubricating it with synthetic grease.</p> <p><b>NOTICE!</b> Before inserting the replacement O-ring, clean the retaining slots with a cleaning solution.</p>
48	<p>Remove the stem guide (20), the stem (6) and the key (28).</p> <p><b>NOTICE!</b> Lubricate the stem surface with silicone grease; make sure that the key (28) is in the correct position in the stem (6).</p>
49	<p>Put the lower lid (3) in place and fix it on the plug guide (70).</p> <p><b>NOTICE!</b> Match the hole for the passage of the loading pressure to the similar one on the plug guide.</p>
50	<p>Insert and fix the screws of the lower section (27) according to the following tightening torque:</p> <ul style="list-style-type: none"> <li>• 1": Tab. 9.98</li> <li>• 2": Tab. 9.99</li> </ul> <p><b>NOTICE!</b> Tighten the screws as shown in the diagram at "9.4.2.2 - Cross diagram for tightening screws".</p>
51	Put the diaphragm unit in place.
52	<p>Insert and fix the piston guide (11) according to the following tightening torques:</p> <ul style="list-style-type: none"> <li>• 1": Tab. 9.98</li> <li>• 2": Tab. 9.99</li> </ul> <p><b>NOTICE!</b> In this step, keep the diaphragm unit still, fitting the compass wrench into the holes in the upper diaphragm support (13).</p>
53	<p>Put the upper lid (3) in place, taking care to fit the indicator rod (18) into the gap between the upper diaphragm support (13) and the piston guide (11).</p> <p><b>NOTICE!</b></p> <ul style="list-style-type: none"> <li>• The indicator rod (18) must not obstruct the hole on the upper diaphragm support (13);</li> <li>• The flange stroke indicator is perpendicular to the gas flow and is visible.</li> </ul>
54	Place the pilot support screw (98).
55	Fix the nut (26).
56	<p>Insert and fix the screws (25) with the nuts (26) according to the following tightening torques:</p> <ul style="list-style-type: none"> <li>• 1": Tab. 9.98</li> <li>• 2": Tab. 9.99</li> </ul>
57	<p>Put the spacer (22) and the spring (80) in place.</p> <p><b>NOTICE!</b> Fit the spacer (22) so that the stop with the narrower hole rests on the surface of the stem (6).</p>
58	Insert the plug (71).

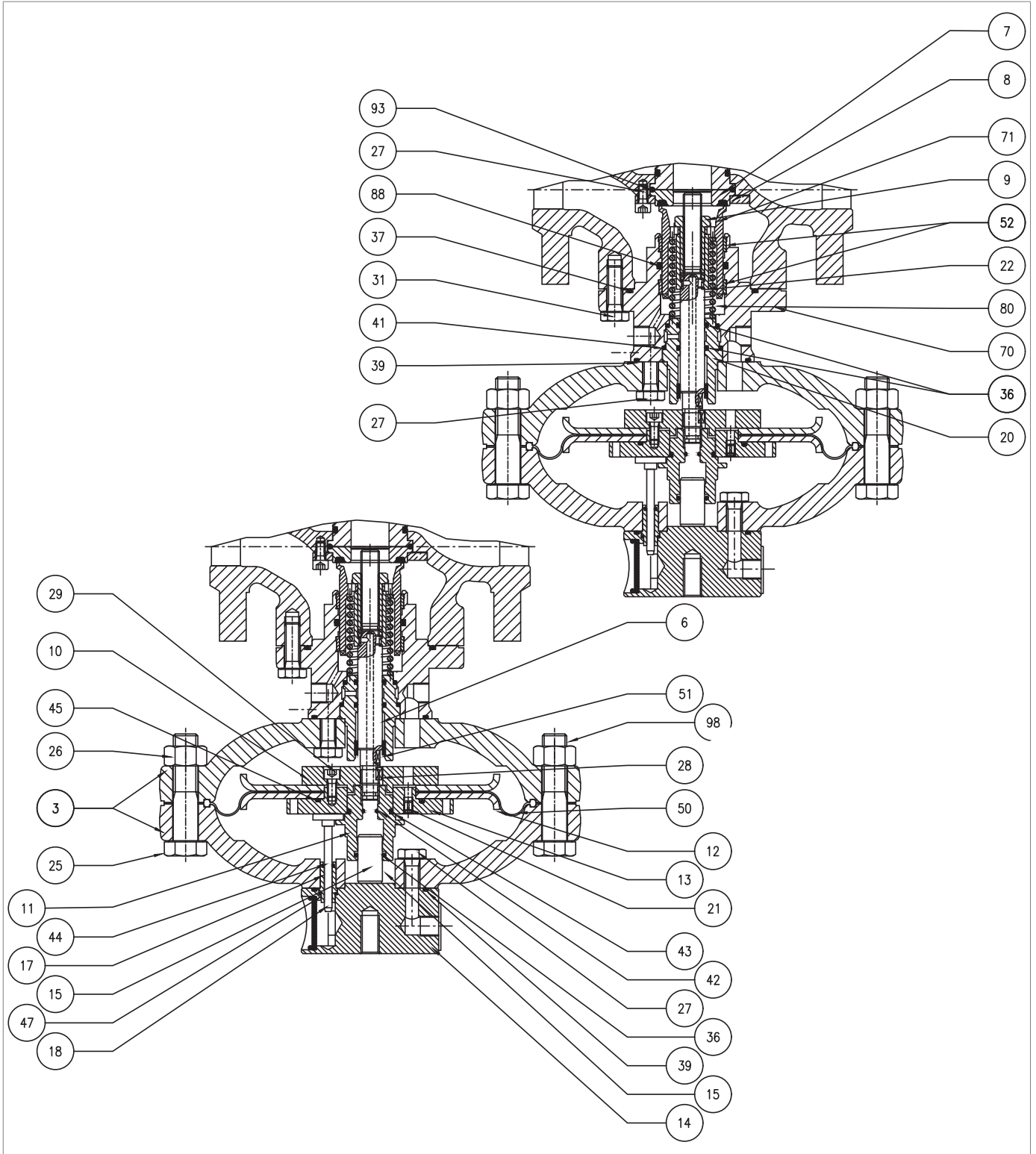

Built-in monitor PM/819 1"÷ 2"

Step	Action
59	<p>Insert the locking nut (9) according to the following tightening torques:</p> <ul style="list-style-type: none"> <li>• 1": Tab. 9.98</li> <li>• 2": Tab. 9.99</li> </ul> <p><b>! NOTICE!</b></p> <p><b>Before fixing the lock nut (9), check that the spring (80) is well seated in the appropriate centring stop on the plug guide (70).</b></p>
60	<p>Position the reduction unit, supporting it carefully.</p> <p><b>! NOTICE!</b></p> <p><b>Lubricate the stem surface with silicone grease; make sure that the key (28) is in the correct position in the stem (6).</b></p>
61	<p>Fit and fix the screws (31) according to the following tightening torques:</p> <ul style="list-style-type: none"> <li>• 1": Tab. 9.98</li> <li>• 2": Tab. 9.99</li> </ul> <p><b>! NOTICE!</b></p> <p><b>Tighten the screws as shown in the diagram at "9.4.2.2 - Cross diagram for tightening screws".</b></p>

Tab. 9.133

**! WARNING!**

**Ensure that all parts have been fitted correctly.**

**9.4.5.2 - BUILT-IN MONITOR PM/819 3"÷ 4"**

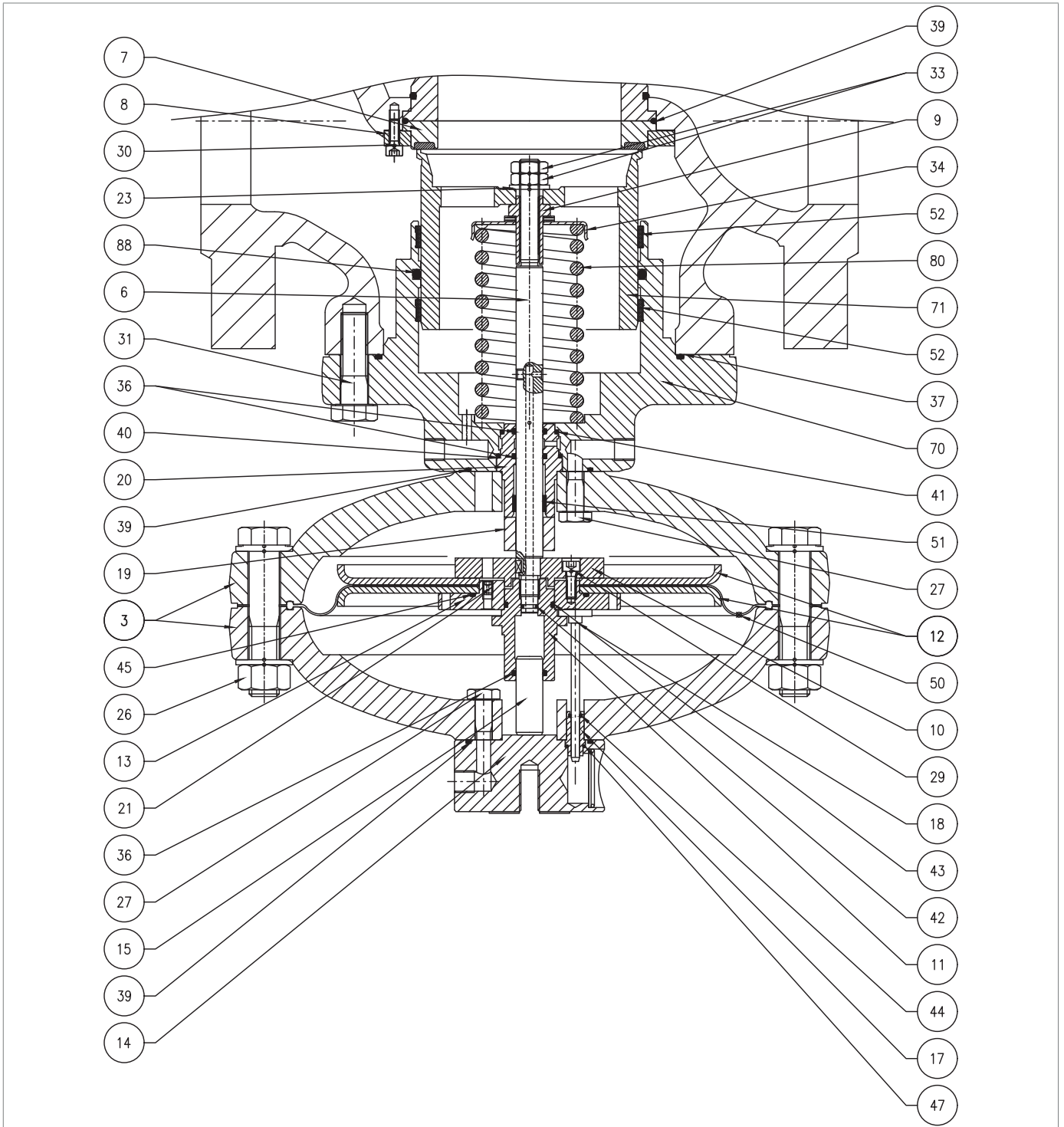
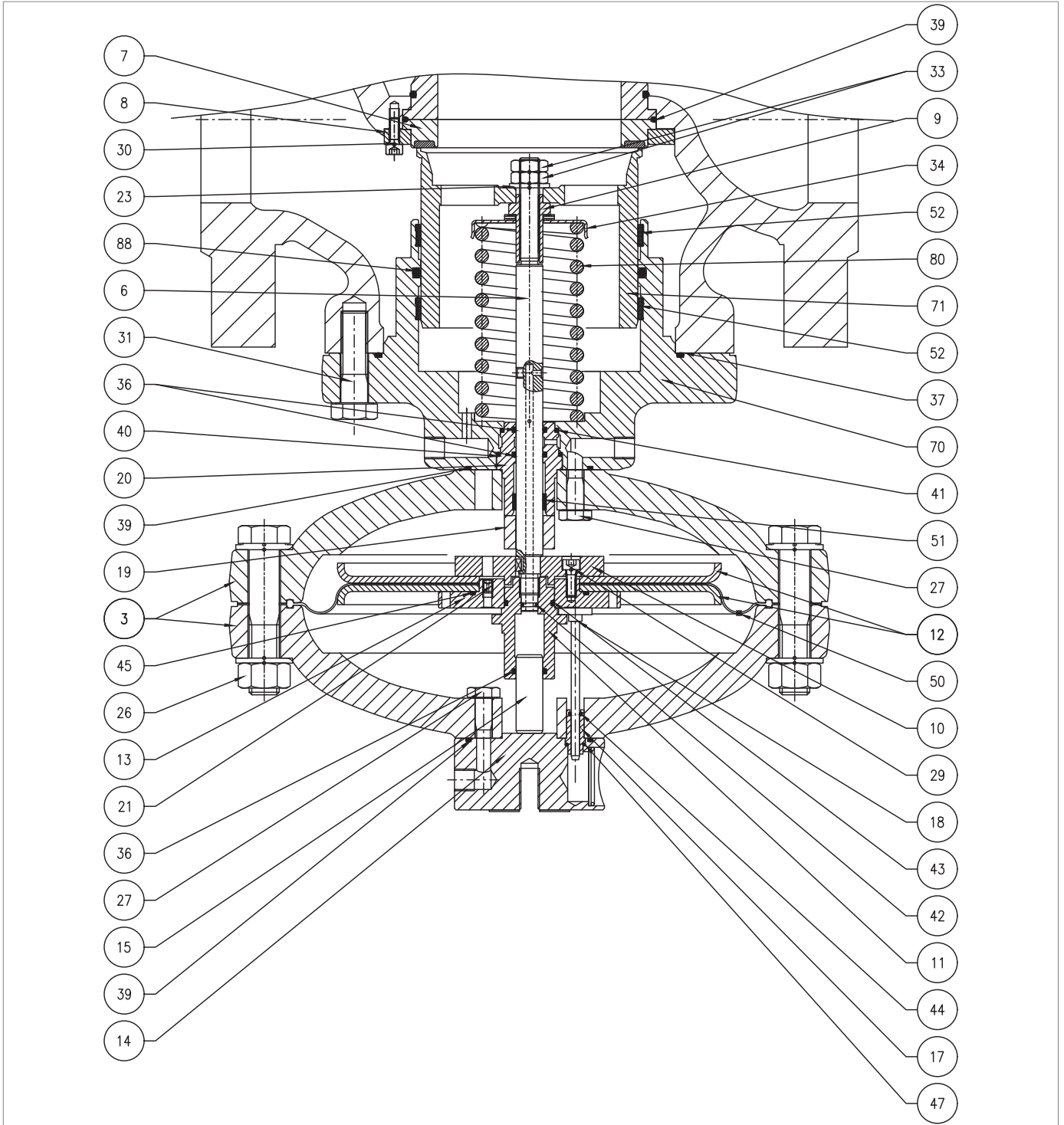

Fig. 9.62. Built-in monitor PM/819 3"÷ 4"

Step	Action
1	Undo and remove the screws (31). <b>NOTICE!</b> <b>Support the head assembly during this step to avoid falls.</b>
2	Remove the reduction unit and place it on its side, on an anti-shock surface. <b>NOTICE!</b> <b>Take care not to damage the plug profile (71).</b>
3	Remove the O-ring (37) from the plug guide (70) and replace it, lubricating it with synthetic grease. <b>NOTICE!</b> <b>Before inserting the replacement O-ring, clean the retaining slots with a cleaning solution.</b>
4	Unscrew and remove the screws (30), the shaft collar (8) and the reinforced gasket (7), preventing them from falling. <b>NOTICE!</b> <b>Carefully prevent the sleeve from falling.</b>
5	Remove the O-ring (39) from the reinforced gasket (7) and replace it, lubricating it with synthetic grease. <b>NOTICE!</b> <b>Before inserting the replacement O-ring, clean the retaining slots with a cleaning solution.</b>
6	Position the reinforced gasket (7) and the shaft collar (8).
7	Insert and fix the screws (30) according to the following tightening torques: <ul style="list-style-type: none"> <li>• 3": Tab. 9.100</li> <li>• 4": Tab. 9.101</li> </ul> <b>NOTICE!</b> <b>Tighten the screws as shown in the diagram at "9.4.2.2 - Cross diagram for tightening screws".</b>
8	Unscrew and remove the nuts (33) together with the washer (23).
9	Remove the plug (71) and place it on an anti-shock surface.
10	Unscrew the lock nut (9).
11	Remove the spring (80) and the spring support (34).
12	Remove and replace the I/DWR rings (52) from the plug guide (70). <b>NOTICE!</b> <b>Before inserting the replacement I/DWR rings, clean the retaining slots with a cleaning solution.</b>
13	Remove the O-ring (88) from the plug (70) and replace it, lubricating it with synthetic grease. <b>NOTICE!</b> <b>Before inserting the replacement O-ring, clean the retaining slots with a cleaning solution.</b>
14	Clean the plug (70) and the plug guide (71), lubricating with silicone grease.
15	Unscrew and remove the nuts (26) together with the screws (25, 98).
16	Remove the upper lid (3).



*Built-in monitor PM/819 3"÷ 4"*

Step	Action
17	Remove the indicator rod (18) from the rod guide (17).
18	Undo and remove the upper screws (27).
19	Separate the upper cover (3) from the eyebolt flange (14).
20	Take out the rod guide (17).
21	Remove the O-rings (39, 47) from the eyebolt flange (14) and replace them, lubricating them with synthetic grease. <div style="border: 1px solid black; padding: 5px;"><b>! NOTICE!</b>  <b>Before inserting the replacement O-rings, clean the retaining slots with a cleaning solution.</b></div>
22	Remove the O-ring (44) from the rod guide (17) and replace it, lubricating it with synthetic grease. <div style="border: 1px solid black; padding: 5px;"><b>! NOTICE!</b>  <b>Before inserting the replacement O-ring, clean the retaining slots with a cleaning solution.</b></div>
23	Place the rod guide (17) in the eyebolt flange (14).
24	Assemble the eyebolt flange (14) with the upper lid (3).
25	Insert and fix the upper screws (27) according to the following tightening torques: <ul style="list-style-type: none"> <li>• 3": Tab. 9.100</li> <li>• 4": Tab. 9.101</li> </ul> <div style="border: 1px solid black; padding: 5px;"><b>! NOTICE!</b>  <b>Tighten the screws as shown in the diagram at "9.4.2.2 - Cross diagram for tightening screws".</b></div>
26	Insert the indicator rod (18) into the rod guide (17).
27	Unscrew and remove the piston guide (11). <div style="border: 1px solid black; padding: 5px;"><b>! NOTICE!</b>  <b>In this step, keep the diaphragm unit still, fitting the compass wrench into the holes in the upper diaphragm support (13).</b></div>
28	Remove the balancing piston (15) from the piston guide (11).
29	Remove the O-rings (36, 43) from the eyebolt flange (11) and replace them, lubricating them with synthetic grease. <div style="border: 1px solid black; padding: 5px;"><b>! NOTICE!</b>  <b>Before inserting the replacement O-rings, clean the retaining slots with a cleaning solution.</b></div>
30	Place the balancing piston (15) in the piston guide (11).
31	Take out the diaphragm unit.
32	Undo and remove the screws (29) from the lower diaphragm support (10).
33	Remove the diaphragm support (10) and the lower diaphragm protection disc (12).
34	Remove the diaphragm (50).
35	Remove the upper diaphragm support (13) from the upper diaphragm protection disc (12).
36	Remove and replace the O-ring (45) from the upper diaphragm support (13), lubricating it with synthetic grease. <div style="border: 1px solid black; padding: 5px;"><b>! NOTICE!</b>  <b>Before inserting the replacement O-ring, clean the retaining slots with a cleaning solution.</b></div>

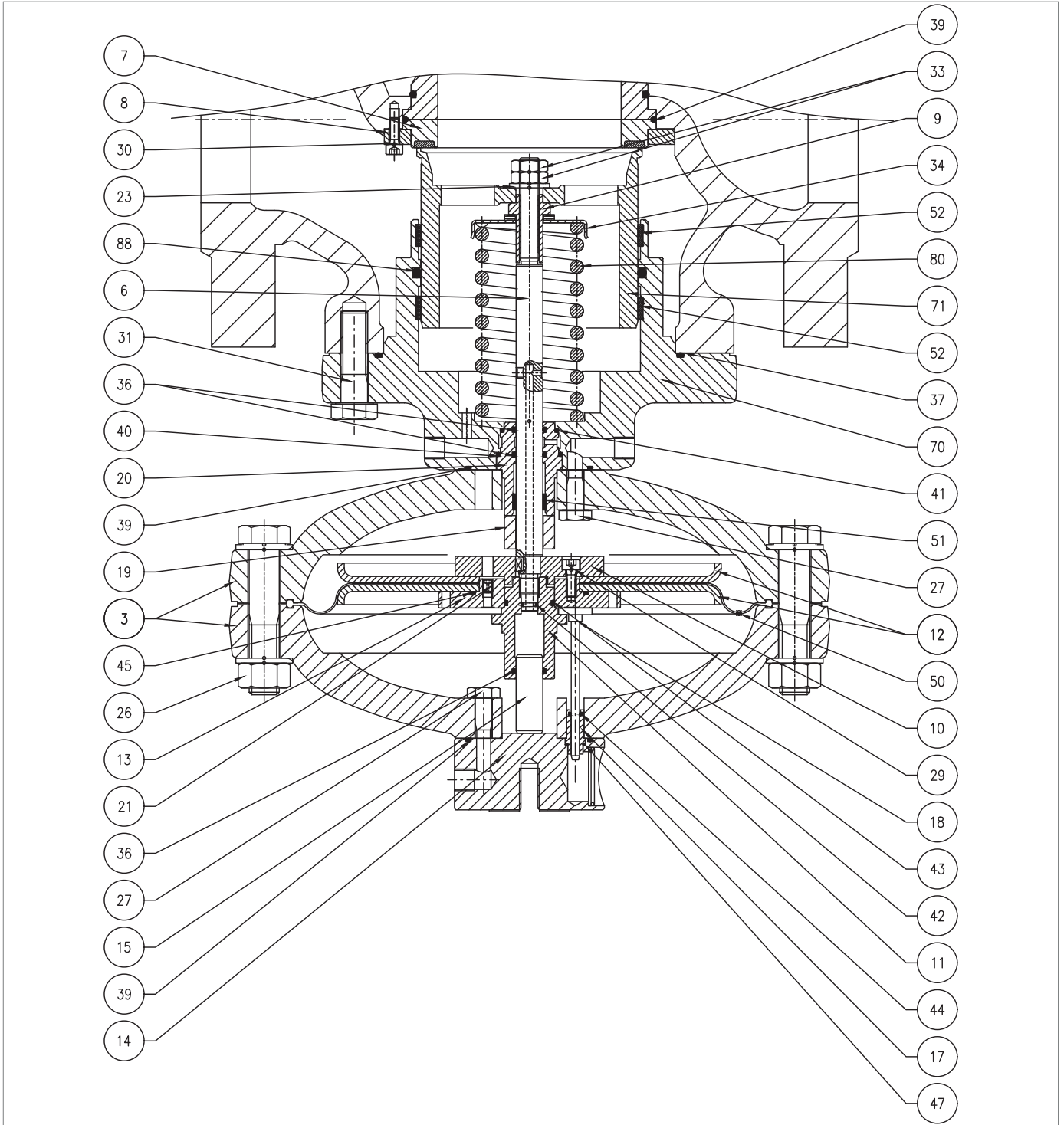

*Built-in monitor PM/819 3"÷ 4"*

Step	Action
37	<p>Put the upper diaphragm support (13) back in place into the upper diaphragm protection disc (12).</p> <p><b>! NOTICE!</b></p> <p><b>Check that the transfer hole (21) is free of dirt or foreign bodies.</b></p>
38	<p>Fit the new diaphragm (50).</p> <p><b>! NOTICE!</b></p> <p><b>Fit the diaphragm so that its convulsion is oriented towards the loading chamber.</b></p>
39	<p>Put the lower diaphragm protection disc (12) and the lower diaphragm support (10) in place.</p> <p><b>! NOTICE!</b></p> <p><b>Check that the nozzle hole on the upper diaphragm support (13) is aligned with the hole on the lower diaphragm support (10).</b></p>
40	<p>Apply thread locking glue to insert and fix the screws (29) according to the following tightening torques:</p> <ul style="list-style-type: none"> <li>• 3": Tab. 9.100</li> <li>• 4": Tab. 9.101</li> </ul> <p><b>! NOTICE!</b></p> <p><b>Tighten the screws as shown in the diagram at "9.4.2.2 - Cross diagram for tightening screws".</b></p>
41	Undo and remove the lower screws (27).
42	Remove the lower cover (3).
43	<p>Remove the O-ring (39) from the plug guide (70) and replace it, lubricating it with synthetic grease.</p> <p><b>! NOTICE!</b></p> <p><b>Before inserting the replacement O-ring, clean the retaining slots with a cleaning solution.</b></p>
44	Remove the spacer (19), the stem guide (20) the stem (6) and the key (28).
45	<p>Remove and replace the I/DWR rings (51) from the stem guide (20).</p> <p><b>! NOTICE!</b></p> <p><b>Before inserting the replacement I/DWR, clean the retaining slots with a cleaning solution.</b></p>
46	<p>Remove the O-rings (36) from the stem guide (20) and replace them, lubricating them with synthetic grease.</p> <p><b>! NOTICE!</b></p> <p><b>Before inserting the replacement O-rings, clean the retaining slots with a cleaning solution.</b></p>
47	<p>Remove the O-rings (40, 41) from the stem guide (20) and replace them, lubricating them with synthetic grease.</p> <p><b>! NOTICE!</b></p> <p><b>Before inserting the replacement O-rings, clean the retaining slots with a cleaning solution.</b></p>

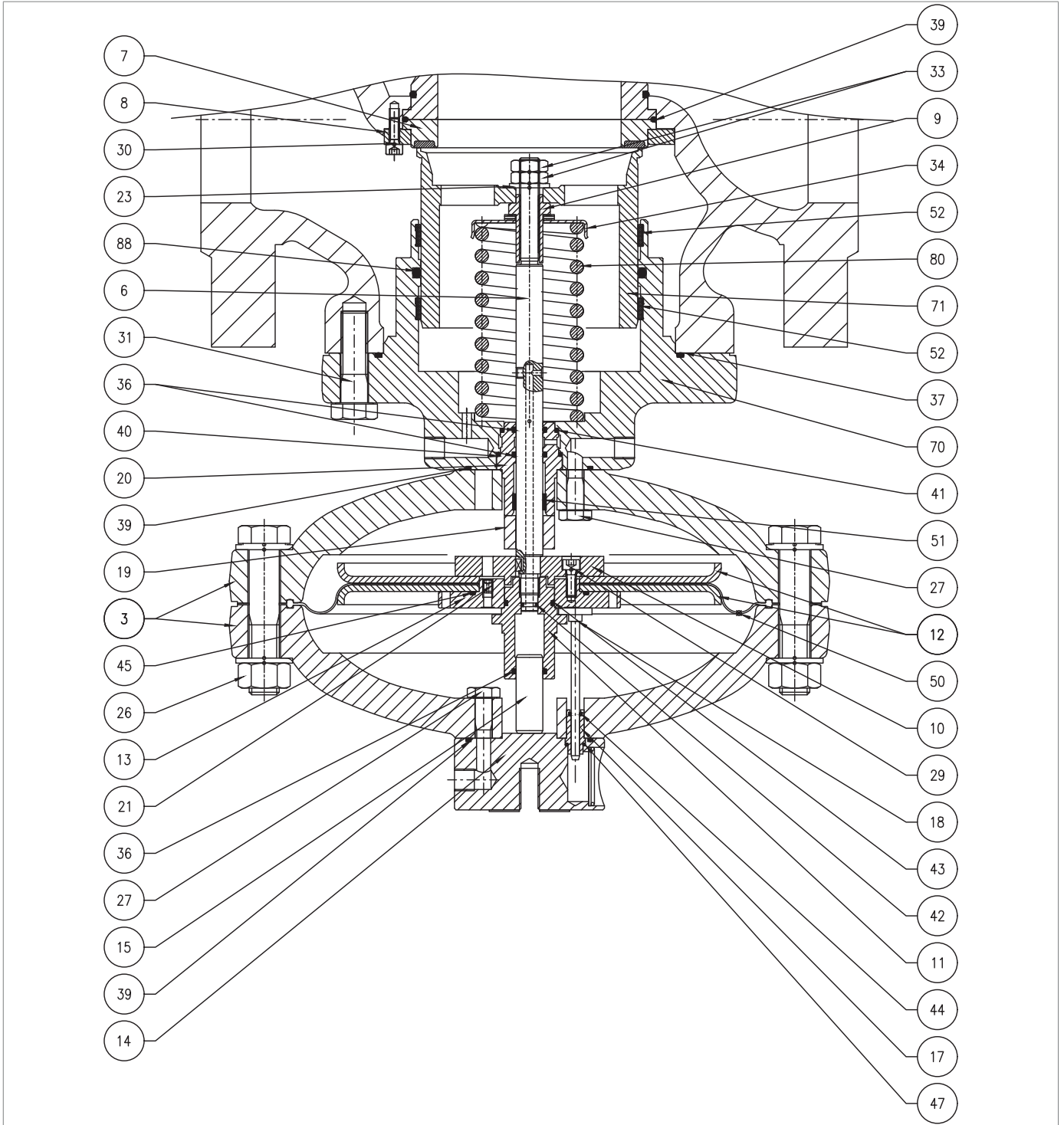

*Built-in monitor PM/819 3"÷ 4"*

Step	Action
48	<p>Remove the O-ring (42) from the stem (6) and replace it, lubricating it with synthetic grease.</p> <p><b>! NOTICE!</b></p> <p><b>Before inserting the replacement O-ring, clean the retaining slots with a cleaning solution.</b></p>
49	<p>Remove the stem guide (20), the stem (6) the spacer (19) and the key (28).</p> <p><b>! NOTICE!</b></p> <ul style="list-style-type: none"> <li>• <b>Lubricate the rod surface with silicone grease;</b></li> <li>• <b>Make sure that the key (28) is in the correct position in the stem (6).</b></li> </ul>
50	<p>Put the lower lid (3) in place and fix it on the plug guide (70).</p> <p><b>! NOTICE!</b></p> <p><b>The hole for the passage of the loading pressure must match the similar one on the plug guide.</b></p>
51	<p>Insert and fix the lower screws (27) according to the following tightening torques:</p> <ul style="list-style-type: none"> <li>• 3": Tab. 9.100</li> <li>• 4": Tab. 9.101</li> </ul> <p><b>! NOTICE!</b></p> <p><b>Tighten the screws as shown in the diagram at "9.4.2.2 - Cross diagram for tightening screws".</b></p>
52	<p>Put the diaphragm unit in place.</p> <p><b>! NOTICE!</b></p> <p><b>Before inserting the diaphragm unit, clean the retaining slots of the lids (3) with a cleaning solution.</b></p>
53	<p>Insert and fix the piston guide (11) according to the following tightening torques:</p> <ul style="list-style-type: none"> <li>• 3": Tab. 9.100</li> <li>• 4": Tab. 9.101</li> </ul> <p><b>! NOTICE!</b></p> <p><b>In this step, keep the diaphragm unit still, fitting the compass wrench into the holes in the upper diaphragm support (13).</b></p>
54	<p>Put the upper lid (3) in place, taking care to fit the indicator rod (18) into the gap between the upper diaphragm support (13) and the piston guide (11).</p> <p><b>! NOTICE!</b></p> <ul style="list-style-type: none"> <li>• <b>The indicator rod (18) must not obstruct the hole on the upper diaphragm support (13);</b></li> <li>• <b>The eyebolt flange stroke indicator (14) must be perpendicular to the gas flow and visible.</b></li> </ul>
55	<p>Insert and fix the screws (25, 98) with the nuts (26) according to the following tightening torques:</p> <ul style="list-style-type: none"> <li>• 3": Tab. 9.100</li> <li>• 4": Tab. 9.101</li> </ul> <p><b>! NOTICE!</b></p> <p><b>Tighten the screws as shown in the diagram at "9.4.2.2 - Cross diagram for tightening screws".</b></p>
56	<p>Put the spring (80) and spring support back (34) back in place.</p>

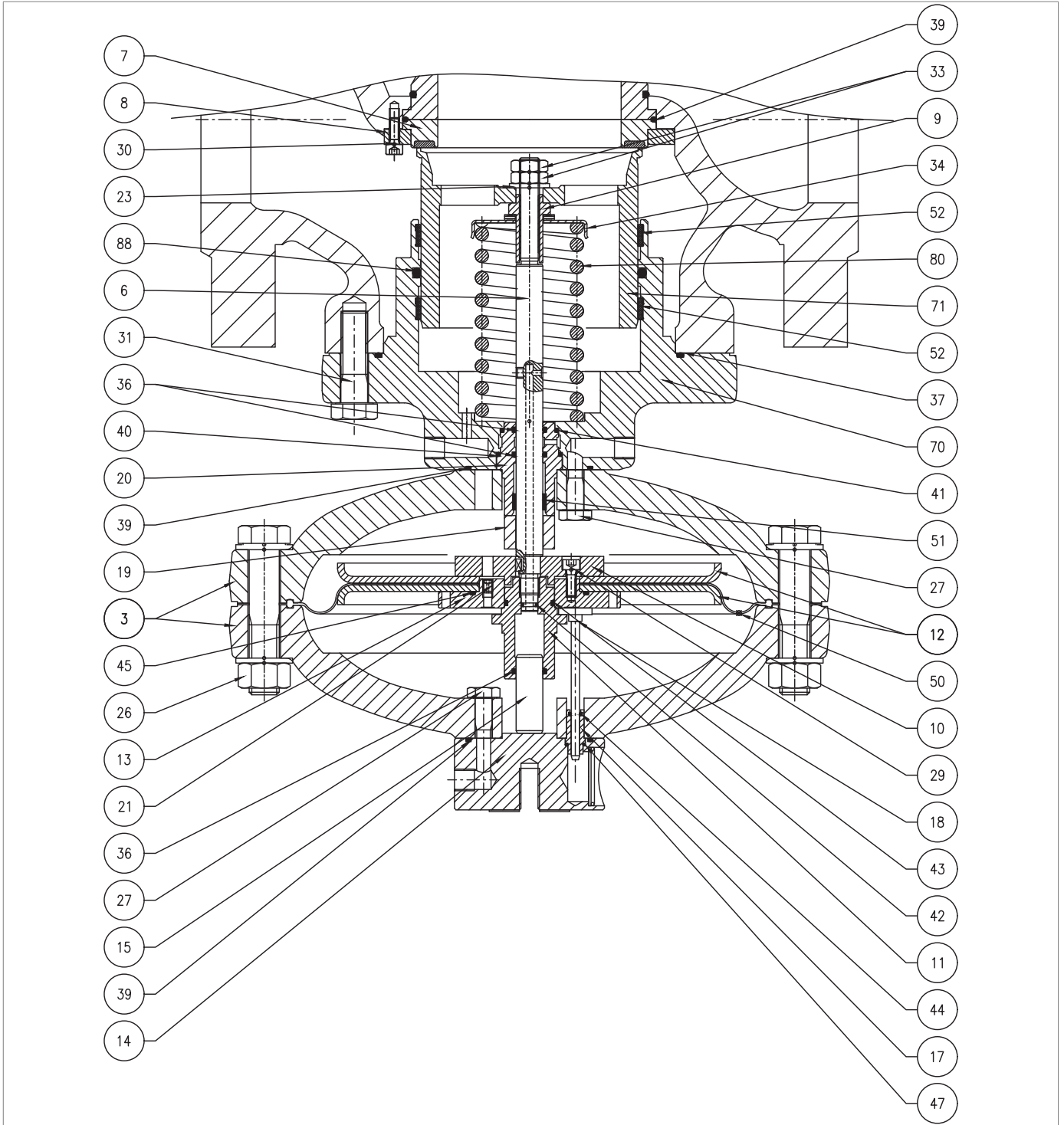

*Built-in monitor PM/819 3"÷ 4"*

Step	Action
57	<p>Insert the lock nut (9) together with the radial bearing (30) according to the tightening torques:</p> <ul style="list-style-type: none"> <li>• 3": Tab. 9.100</li> <li>• 4": Tab. 9.101</li> </ul> <p><b>NOTICE!</b></p> <p><b>Before fixing the lock nut (9), check that the spring (80) is well seated in the appropriate centring stop on the plug guide (70).</b></p>
58	Put the plug (71) in place lubricating the surface with silicone grease.
59	<p>Position the washer (23) and the nuts (33), fixing them to the tightening torque indicated in the relative table.</p> <p><b>NOTICE!</b></p> <p><b>Before fitting the external nut (33), apply thread locking glue.</b></p>
60	Position the reduction unit, supporting it carefully.
61	<p>Fit and fix the screws (31) according to the following tightening torques:</p> <ul style="list-style-type: none"> <li>• 3": Tab. 9.100</li> <li>• 4": Tab. 9.101</li> </ul> <p><b>NOTICE!</b></p> <p><b>Tighten the screws as shown in the diagram at "9.4.2.2 - Cross diagram for tightening screws".</b></p>

Tab. 9.134

**! WARNING!**

**Ensure that all parts have been fitted correctly.**

9.4.5.3 - BUILT-IN MONITOR PM/819 6"÷ 10"

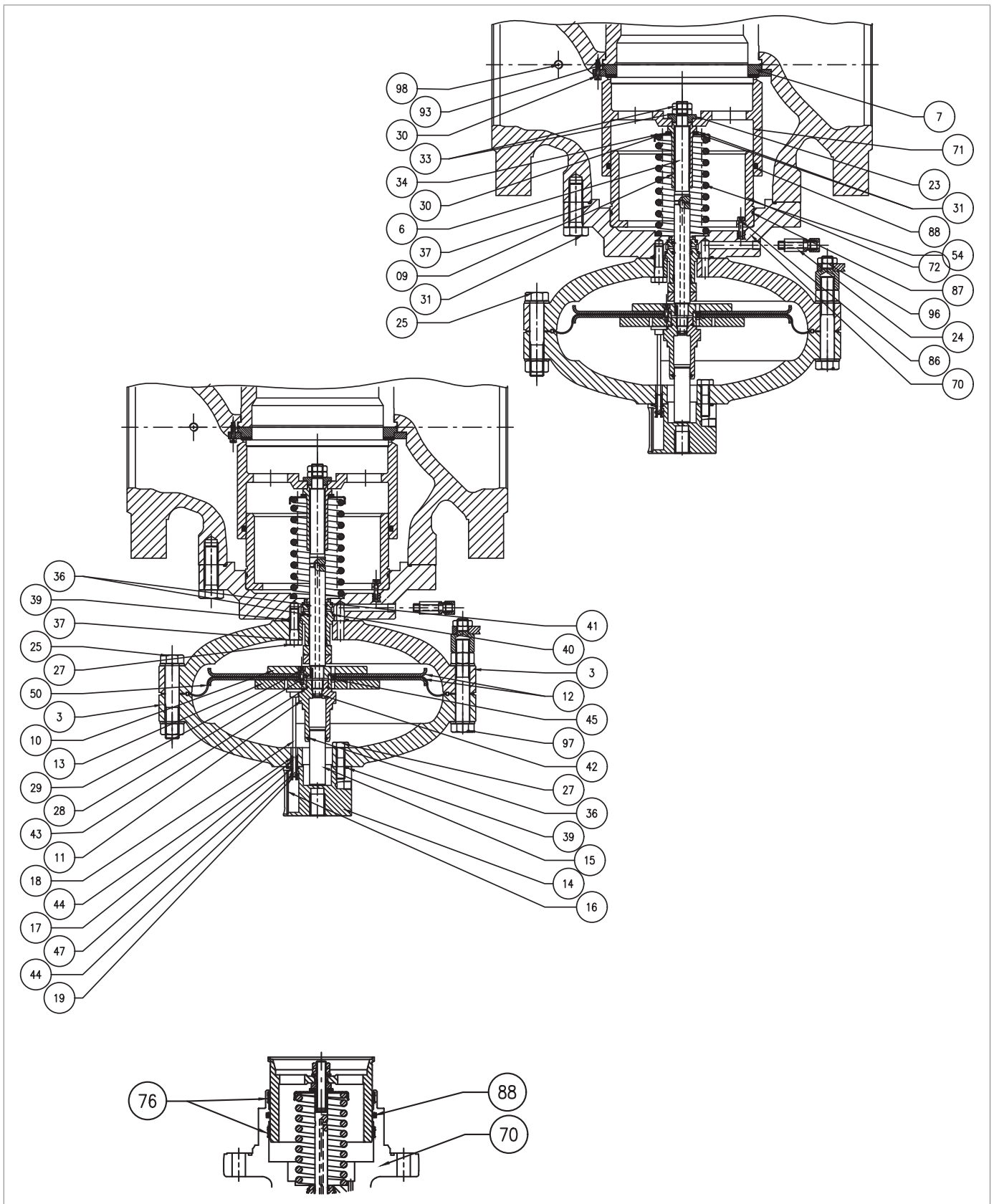
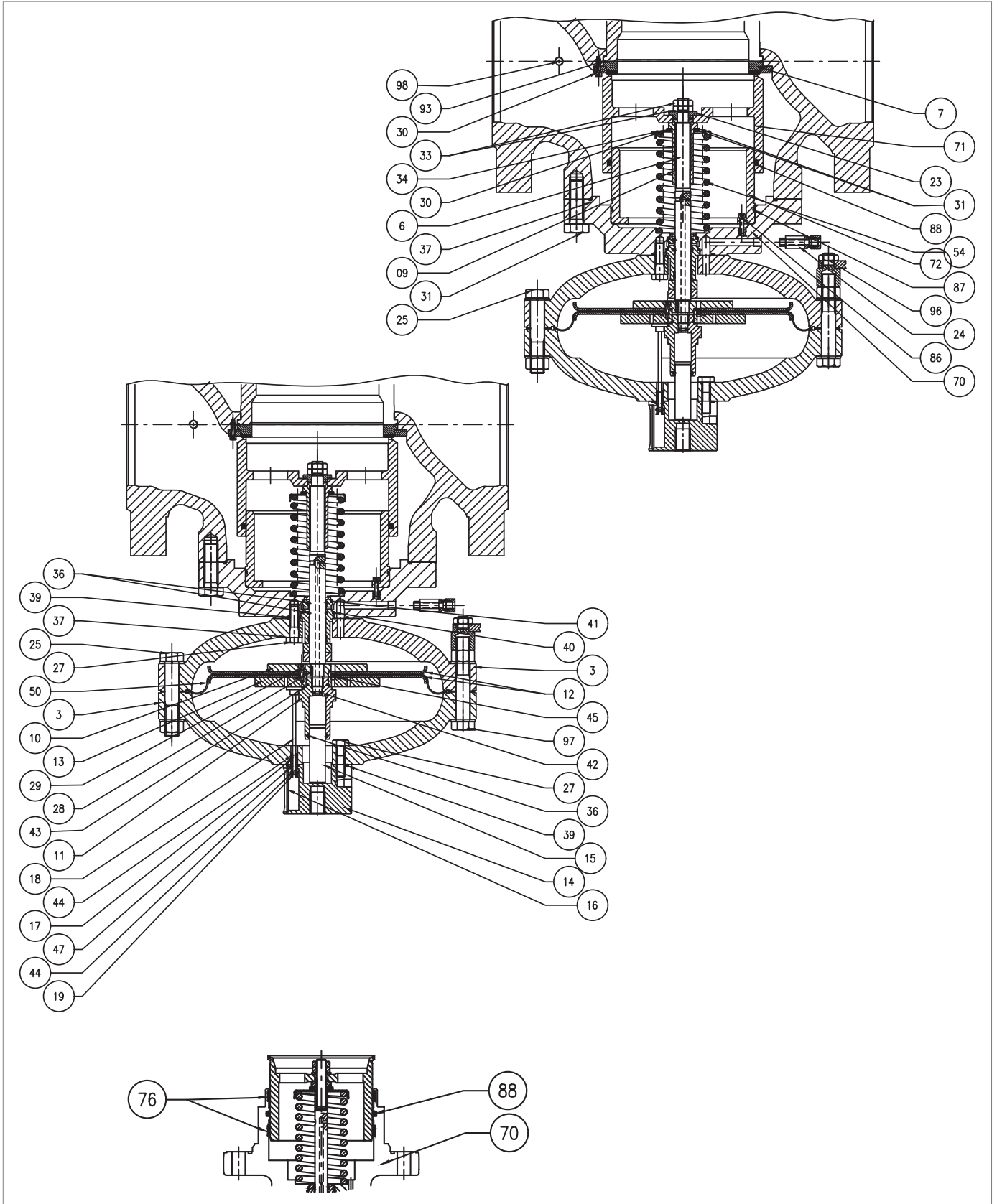

Fig. 9.63. Built-in monitor PM/819 6"÷ 10"

Step	Action
1	Undo and remove the screws (31). <b>NOTICE!</b> <b>Support the head assembly during this step to avoid falls.</b>
2	Remove the reduction unit and place it on its side and on an anti-shock surface. <b>NOTICE!</b> <b>Take care not to damage the plug profile (71).</b>
3	Remove the O-ring (37) from the plug guide (70) and replace it, lubricating it with synthetic grease. <b>NOTICE!</b> <b>Before inserting the replacement O-ring, clean the retaining slots with a cleaning solution.</b>
4	Unscrew and remove the screws (30), the shaft collar (8) and the reinforced gasket (7), preventing them from falling. <b>NOTICE!</b> <b>Carefully prevent the sleeve from falling.</b>
5	Remove the O-ring (39) from the reinforced gasket (7) and replace it, lubricating it with synthetic grease. <b>NOTICE!</b> <b>Before inserting the replacement O-ring, clean the retaining slots with a cleaning solution.</b>
6	Position the reinforced gasket (7) and the shaft collar (8).
7	Insert and fix the screws (30) according to the following tightening torques: <ul style="list-style-type: none"> <li>• 6": Tab. 9.102</li> <li>• 8": Tab. 9.103</li> <li>• 10": Tab. 9.104</li> </ul> <b>NOTICE!</b> <b>Tighten the screws as shown in the diagram at "9.4.2.2 - Cross diagram for tightening screws".</b>
8	Unscrew and remove the nuts (33) and the washer (23).
9	Remove the plug (71) and place it on an anti-shock surface.
10	Remove the O-ring (88) from the plug guide (71) and replace it, lubricating it with synthetic grease. <b>NOTICE!</b> <b>Before inserting the replacement O-ring, clean the retaining slots with a cleaning solution.</b>
11	Unscrew and remove the locking nut (9).
12	Remove the radial bearing (130), the spring support (34) and the spring (80).
13	Undo and remove the screws (86).
14	Take out the plug guide (72). <b>NOTICE!</b> <b>In this step, tighten some M6x50 screws into the threaded holes of the plug guide. Then screw them for vertical extraction, so that the plug guide always remains aligned.</b>
15	Remove the screws M6x50.



Built-in monitor PM/819 6"÷ 10"

REFLUX 819/FO

Step	Action
16	Remove the O-ring (87) from the plug guide (72) and replace it, lubricating it with synthetic grease. <b>NOTICE!</b> <b>Before inserting the replacement O-ring, clean the retaining slots with a cleaning solution.</b>
17	Put the plug guide (72) back in place.
18	Insert and fix the screws (86).
19	Remove the screws (57) together with the sight glass (16).
20	Remove the bush (63).
21	Remove the O-ring (44) from the bush (63) and replace it, lubricating it with synthetic grease. <b>NOTICE!</b> <b>Before inserting the replacement O-ring, clean the retaining slots with a cleaning solution.</b>
22	Unscrew and remove the nuts (26) together with the screws (25, 98).
23	Remove the upper lid (3).
24	Remove the indicator rod (18) from the rod guide (17).
25	Undo and remove the screws of the upper section (27).
26	Separate the upper cover (3) from the eyebolt flange (14).
27	Take out the rod guide (17).
28	Remove the O-rings (39, 47) from the eyebolt flange (14) and replace them, lubricating them with synthetic grease. <b>NOTICE!</b> <b>Before inserting the replacement O-rings, clean the retaining slots with a cleaning solution.</b>
29	Remove the O-ring (44) from the rod guide (17) and replace it, lubricating it with synthetic grease. <b>NOTICE!</b> <b>Before inserting the replacement O-ring, clean the retaining slots with a cleaning solution.</b>
30	Place the rod guide (17) in the eyebolt flange (14).
31	Assemble the eyebolt flange (14) with the upper lid (3).
32	Insert and fix the screws of the upper section (27) according to the following tightening torques: <ul style="list-style-type: none"> <li>6": Tab. 9.102</li> <li>8": Tab. 9.103</li> <li>10": Tab. 9.104</li> </ul> <b>NOTICE!</b> <b>Tighten the screws as shown in the diagram at "9.4.2.2 - Cross diagram for tightening screws".</b>
33	Insert the indicator rod (18) into the rod guide (17).
34	Unscrew and remove the piston guide (11). <b>NOTICE!</b> <b>In this step, keep the diaphragm unit still, fitting the compass wrench into the holes in the upper diaphragm support (13).</b>
35	Remove the balancing piston (15) from the piston guide (11).

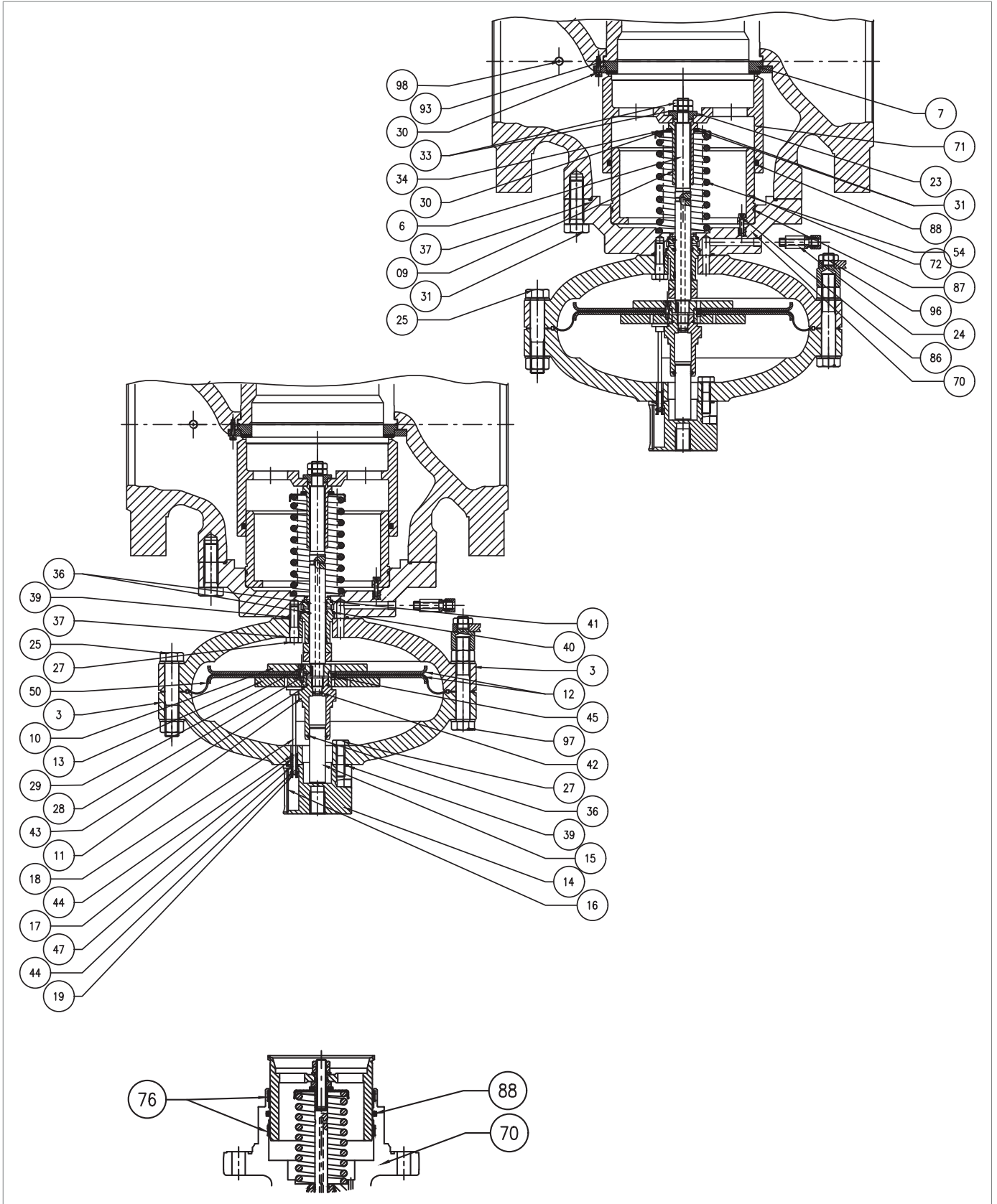

Built-in monitor PM/819 6"÷ 10"

REFLUX 819/FO

Step	Action
36	Remove the O-rings (36, 43) from the eyebolt flange (11) and replace them, lubricating them with synthetic grease. <div style="border: 1px solid black; padding: 5px;">  <b>NOTICE!</b>  <b>Before inserting the replacement O-rings, clean the retaining slots with a cleaning solution.</b> </div>
37	Place the balancing piston (15) in the piston guide (11).
38	Take out the diaphragm unit.
39	Undo and remove the screws (29) from the lower diaphragm support (10).
40	Remove the lower diaphragm support (10) and the lower diaphragm protection disc (12).
41	Remove the diaphragm (50).
42	Remove the upper diaphragm support (13) from the upper diaphragm protection disc (12).
43	Remove and replace the O-ring (45) from the upper diaphragm support (13), lubricating it with synthetic grease. <div style="border: 1px solid black; padding: 5px;">  <b>NOTICE!</b>  <b>Before inserting the replacement O-ring, clean the retaining slots with a cleaning solution.</b> </div>
44	Put the upper diaphragm support (13) back in place into the upper diaphragm protection disc (12). <div style="border: 1px solid black; padding: 5px;">  <b>NOTICE!</b>  <b>Check that the transfer hole (21) is free of dirt or foreign bodies.</b> </div>
45	Fit the new diaphragm (50). <div style="border: 1px solid black; padding: 5px;">  <b>NOTICE!</b>  <b>Fit the diaphragm so that its convulsion is oriented towards the loading chamber.</b> </div>
46	Put the lower diaphragm protection disc (12) and the lower diaphragm support (10) in place. <div style="border: 1px solid black; padding: 5px;">  <b>NOTICE!</b>  <b>Check that the nozzle hole on the upper diaphragm support (13) is aligned with the hole on the lower diaphragm support (10).</b> </div>
47	Apply thread locking glue to insert and fix the screws (29) according to the following tightening torques: <ul style="list-style-type: none"> <li>• 6": Tab. 9.102</li> <li>• 8": Tab. 9.103</li> <li>• 10": Tab. 9.104</li> </ul> <div style="border: 1px solid black; padding: 5px;">  <b>NOTICE!</b>  <b>Tighten the screws as shown in the diagram at "9.4.2.2 - Cross diagram for tightening screws".</b> </div>
48	Remove the spacers (19, 64).
49	Undo and remove the screws of the lower section (27).
50	Remove the lower cover (3).
51	Remove the O-ring (39) from the plug guide (70) and replace it, lubricating it with synthetic grease. <div style="border: 1px solid black; padding: 5px;">  <b>NOTICE!</b>  <b>Before inserting the replacement O-ring, clean the retaining slots with a cleaning solution.</b> </div>
52	Remove the stem guide (20), the stem (6) and the key (28).

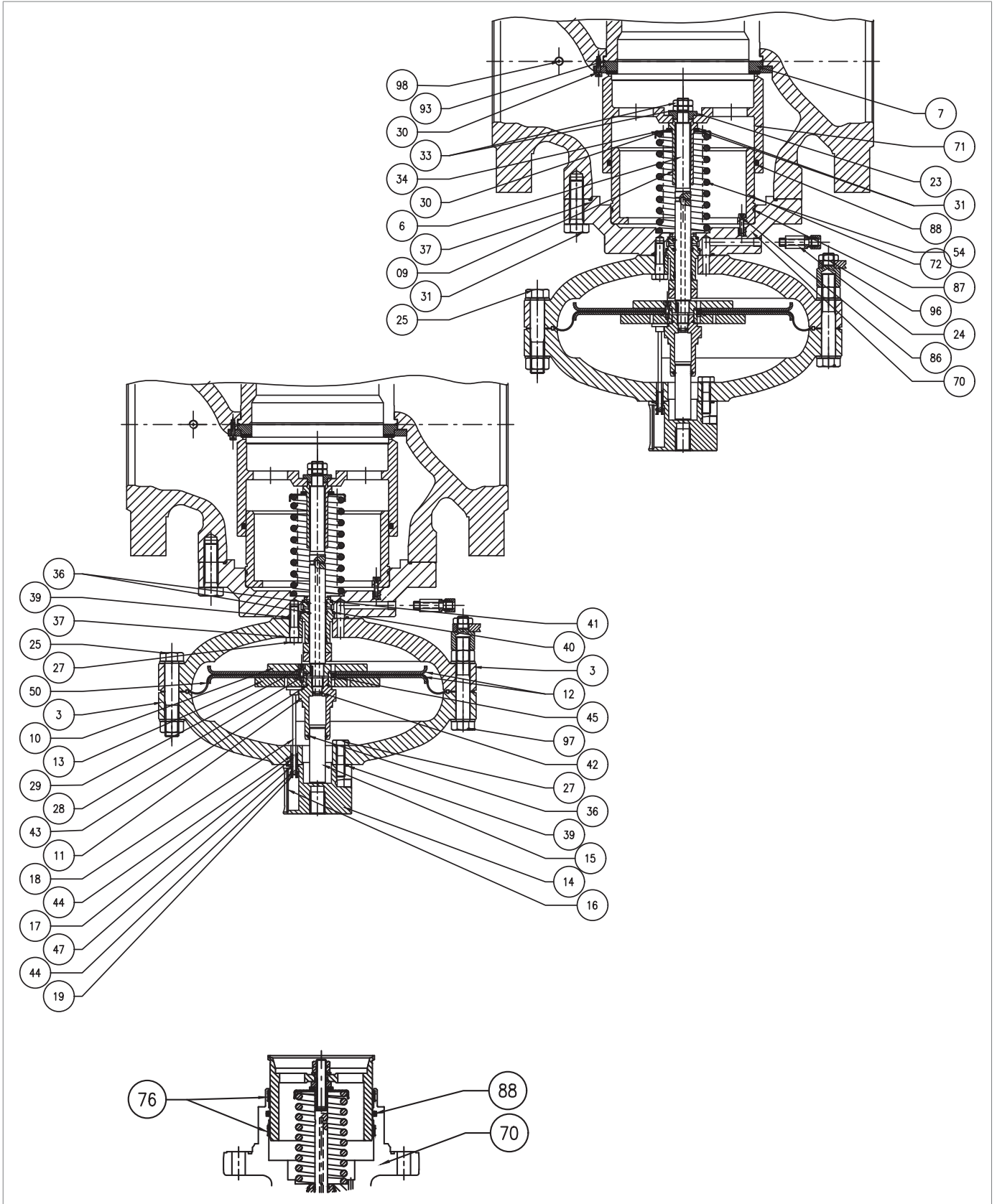

Built-in monitor PM/819 6"÷ 10"

Step	Action
53	<p>Remove the O-ring (41) from the plug guide (70) and replace it, lubricating it with synthetic grease.</p> <p><b>! NOTICE!</b>  <b>Before inserting the replacement O-ring, clean the retaining slots with a cleaning solution.</b></p>
54	<p>Remove the O-rings (40) from the stem guide (20) and replace them, lubricating them with synthetic grease.</p> <p><b>! NOTICE!</b>  <b>Before inserting the replacement O-ring, clean the retaining slots with a cleaning solution.</b></p>
55	<p>Remove and replace the I/DWR rings (51) from the stem guide (20).</p> <p><b>! NOTICE!</b>  <b>Before inserting the replacement I/DWR, clean the retaining slots with a cleaning solution.</b></p>
56	<p>Remove the O-rings (36) from the stem guide (20) and replace them, lubricating them with synthetic grease.</p> <p><b>! NOTICE!</b>  <b>Before inserting the replacement O-rings, clean the retaining slots with a cleaning solution.</b></p>
57	<p>Remove the O-ring (42) from the stem (6) and replace it, lubricating it with synthetic grease.</p> <p><b>! NOTICE!</b>  <b>Before inserting the replacement O-ring, clean the retaining slots with a cleaning solution.</b></p>
58	<p>Remove the stem guide (20), the stem (6) and the key (28).</p> <p><b>! NOTICE!</b></p> <ul style="list-style-type: none"> <li>• Lubricate the rod surface with silicone grease;</li> <li>• Make sure that the key (28) is in the correct position in the stem (6).</li> </ul>
59	<p>Put the lower lid (3) in place and fix it on the plug guide (70).</p> <p><b>! NOTICE!</b>  <b>The hole for the passage of the loading pressure must match the similar one on the plug guide.</b></p>
60	<p>Insert and fix the screws of the lower section (27) according to the following tightening torque:</p> <ul style="list-style-type: none"> <li>• 6": Tab. 9.102</li> <li>• 8": Tab. 9.103</li> <li>• 10": Tab. 9.104</li> </ul> <p><b>! NOTICE!</b>  <b>Tighten the screws as shown in the diagram at "9.4.2.2 - Cross diagram for tightening screws".</b></p>
61	<p>Place the spacers (19, 64).</p>
62	<p>Put the diaphragm unit in place.</p> <p><b>! NOTICE!</b>  <b>Before inserting the diaphragm unit, clean the retaining slots with a cleaning solution.</b></p>

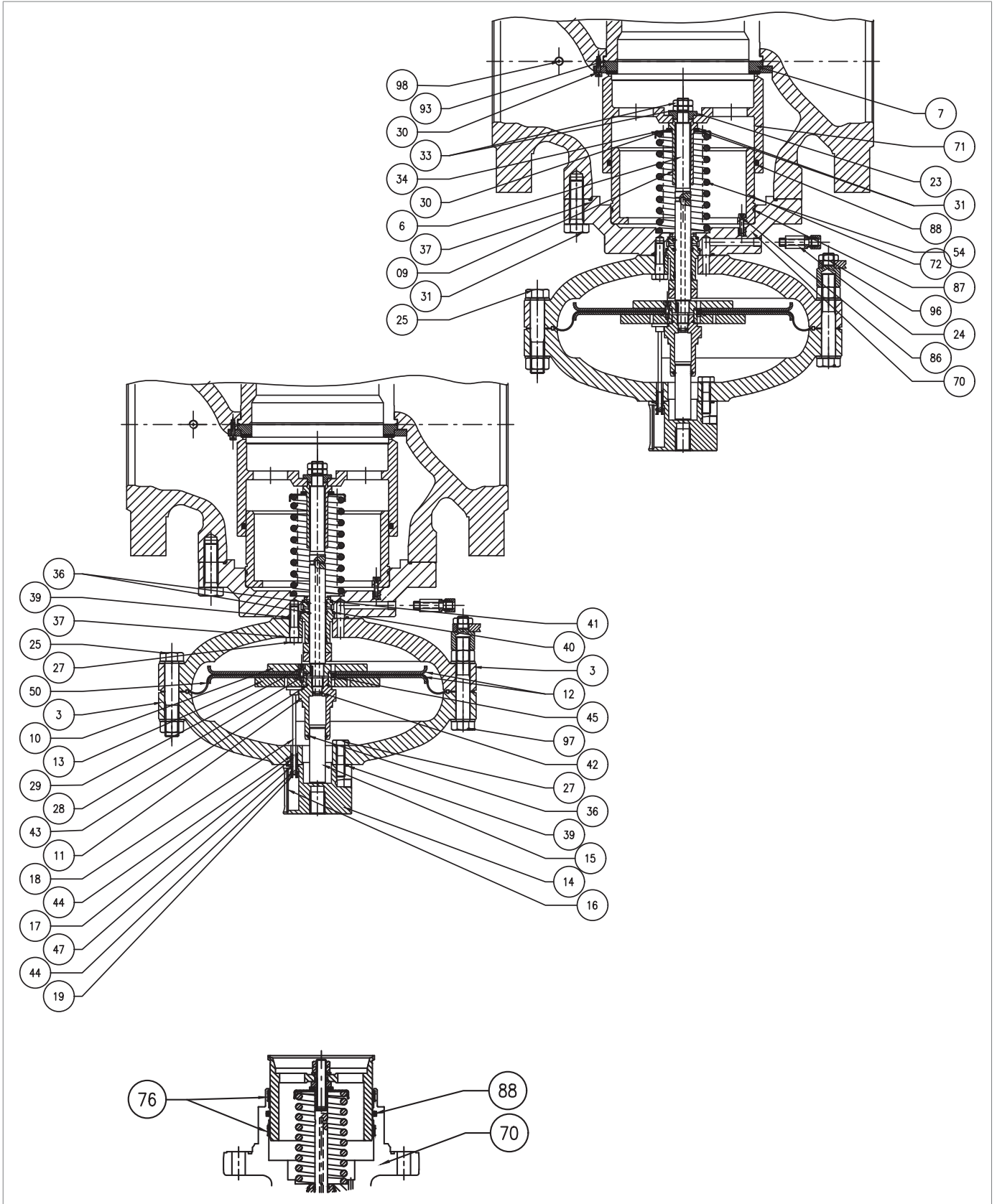

Built-in monitor PM/819 6"÷ 10"

REFLUX 819/FO

Step	Action
63	<p>Insert and fix the piston guide (11) according to the following tightening torques:</p> <ul style="list-style-type: none"> <li>• 6": Tab. 9.102</li> <li>• 8": Tab. 9.103</li> <li>• 10": Tab. 9.104</li> </ul> <p><b>NOTICE!</b></p> <p><b>In this step, keep the diaphragm unit still, fitting the compass wrench into the holes in the upper diaphragm support (13).</b></p>
64	<p>Put the upper lid (3) in place, taking care to fit the indicator rod (18) into the gap between the upper diaphragm support (13) and the piston guide (11).</p> <p><b>NOTICE!</b></p> <ul style="list-style-type: none"> <li>• <b>The indicator rod (18) must not obstruct the hole on the upper diaphragm support (13);</b></li> <li>• <b>The eyebolt flange stroke indicator (14) must be perpendicular to the gas flow and visible.</b></li> </ul>
65	<p>Insert and fix the screws (25, 98) with the nuts (26) according to the following tightening torques:</p> <ul style="list-style-type: none"> <li>• 6": Tab. 9.102</li> <li>• 8": Tab. 9.103</li> <li>• 10": Tab. 9.104</li> </ul> <p><b>NOTICE!</b></p> <p><b>Tighten the screws as shown in the diagram at "9.4.2.2 - Cross diagram for tightening screws".</b></p>
66	Put the spring (80) and spring support back (34) back in place.
67	<p>Insert and fix the lock nut (9) together with the radial bearing (130) according to the tightening torques:</p> <ul style="list-style-type: none"> <li>• 6": Tab. 9.102</li> <li>• 8": Tab. 9.103</li> <li>• 10": Tab. 9.104</li> </ul> <p><b>NOTICE!</b></p> <p><b>Before fixing the lock nut (9), check that the spring (80) is well seated in the appropriate centring stop on the plug guide (70).</b></p>
68	Put the plug (71) in place lubricating the surface with silicone grease.
69	<p>Apply thread locking glue to insert and fix the washer (23) and the nuts (33) according to the following tightening torques:</p> <ul style="list-style-type: none"> <li>• 6": Tab. 9.102</li> <li>• 8": Tab. 9.103</li> <li>• 10": Tab. 9.104</li> </ul>
70	Position the reduction unit, supporting it carefully.
71	<p>Fit and fix the screws (31) according to the following tightening torques:</p> <ul style="list-style-type: none"> <li>• 6": Tab. 9.102</li> <li>• 8": Tab. 9.103</li> <li>• 10": Tab. 9.104</li> </ul> <p><b>NOTICE!</b></p> <p><b>Tighten the screws as shown in the diagram at "9.4.2.2 - Cross diagram for tightening screws".</b></p>
72	Connect the connection pipes between the regulator, the monitor and their pilot units, including the down-stream pressure outlets.

Tab. 9.135

**WARNING!**

**Ensure that all parts have been fitted correctly.**

**9.4.6 - PILOT MAINTENANCE PROCEDURE 200/A/FO AND 200/A SERIES + R14/A/FO AND R14/A PRE-REGULATOR**

**9.4.6.1 - 200/A/FO AND 200/A SERIES PILOT DISCONNECTION + R14/A/FO AND R14/A PRE-REGULATOR**

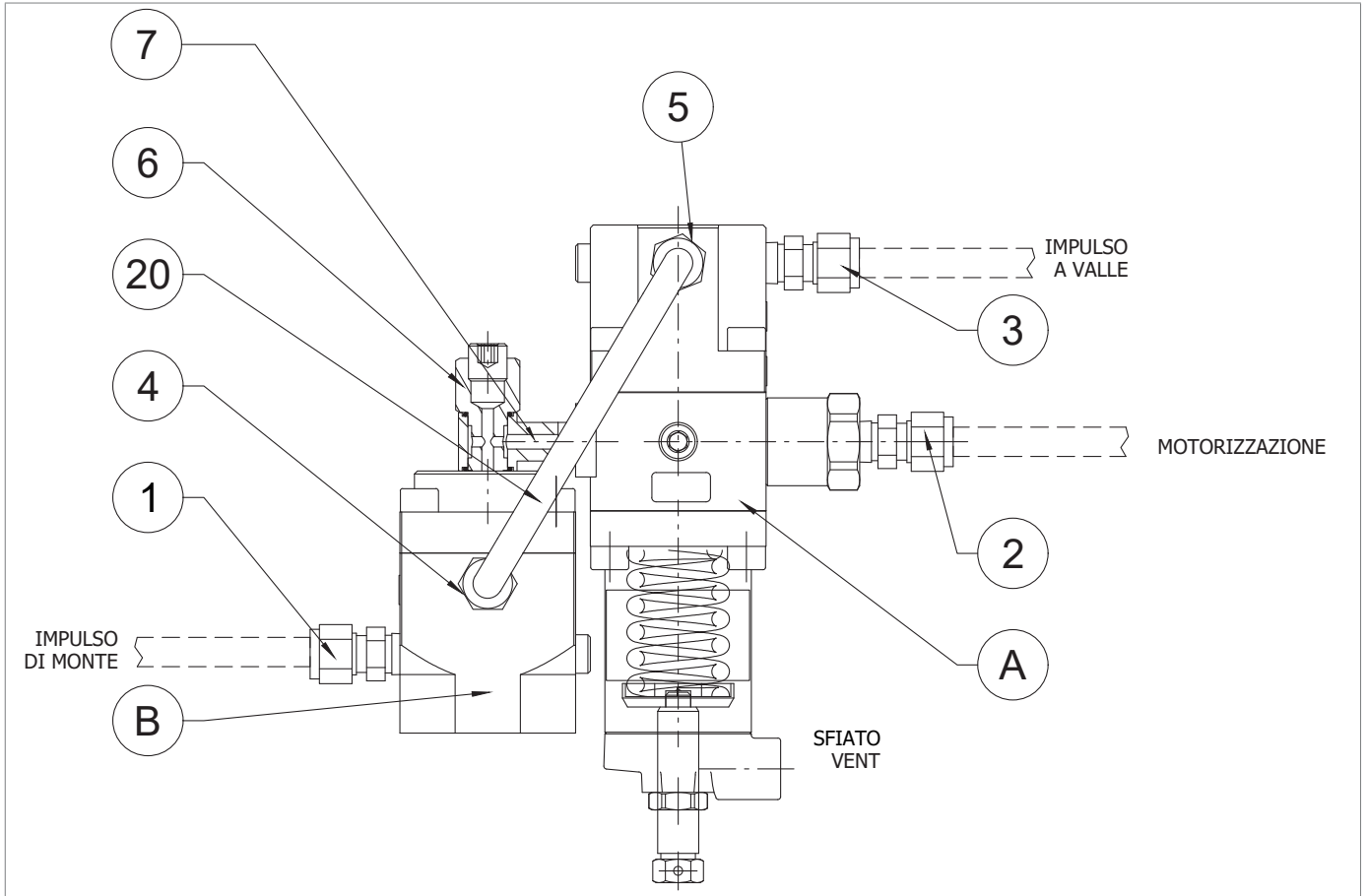
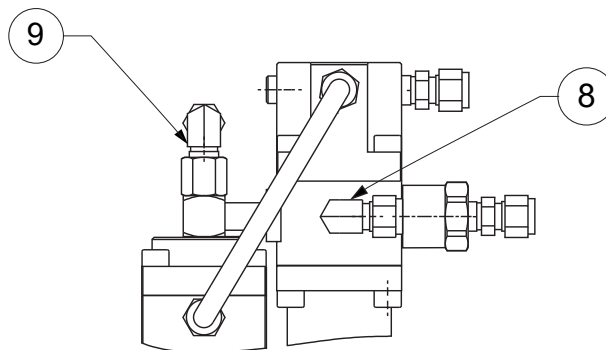

Fig. 9.64. 200/A and R14/A series pilot

**NOTICE!**

The connection to the pilot circuit piping of the 200/A/FO pilot and R14/A/FO pre-regulator is different: please refer to the picture below. Both pilots follow the same disconnection and reconnection procedure.



To disconnect the 200/A/FO series pilot, proceed as in Tab. 9.136:

Step	Action
1	Disconnect the sensing lines between the 200/A/FO pilot and the regulator by adjusting the fittings (2, 3, 8, 9).
2	Unscrew and remove the fixing screw to remove the pilot from the regulator.
3	Remove the pipe (20) by adjusting the fittings (4, 5).
4	Unscrew and remove the screw (6) to separate the R14/A/FO pre-regulator from the pilot.
5	Unscrew and remove the screw (7) from the 200/A/FO pilot.

Tab. 9.136.

To disconnect the 200/A series pilot, proceed as in Tab. 9.137:

Step	Action
1	Disconnect the sensing lines between the 200/A pilot and the regulator by adjusting the fittings (1, 2, 3).
2	Unscrew and remove the fixing screw to remove the pilot from the regulator.
3	Remove the pipe (20) by adjusting the fittings (4, 5).
4	Unscrew and remove the screw (6) to separate the R14/A pre-regulator from the pilot.
5	Undo and remove the screw (7) from pilot 200/A.

Tab. 9.137.

9.4.6.2 - PILOT 204/A/FO-204/A AND 205/A/FO-205/A

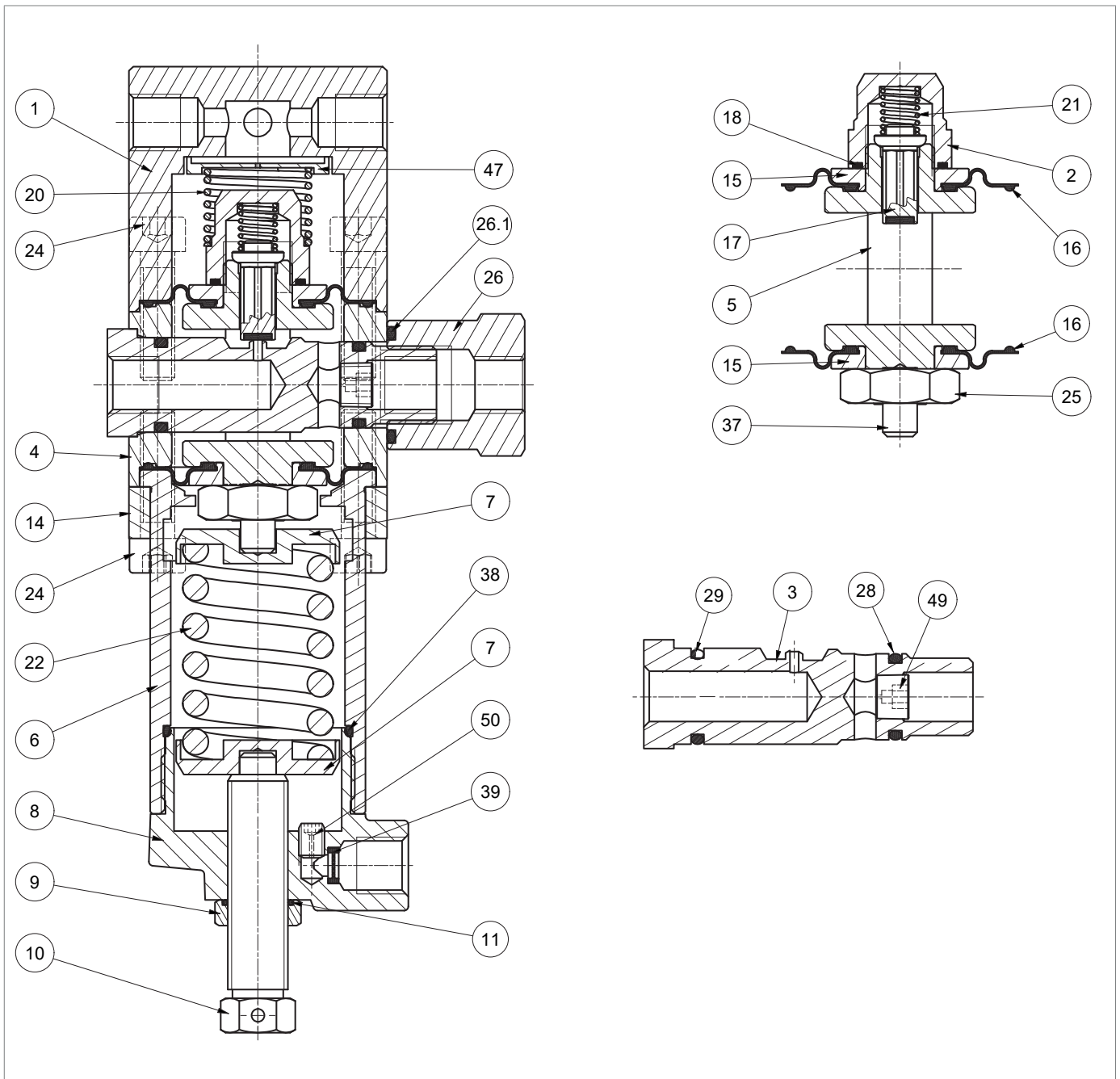





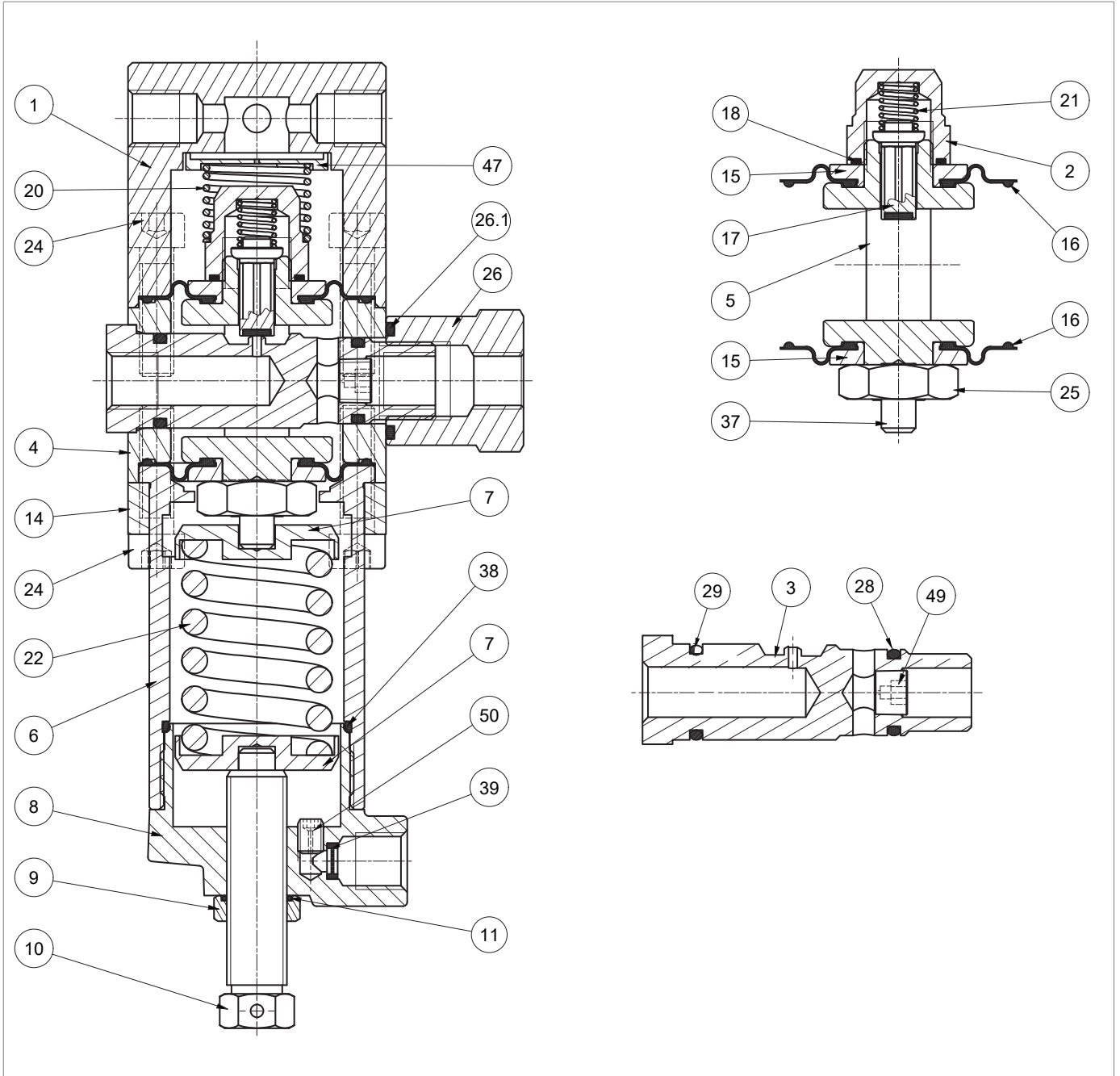

Fig. 9.65. Pilot 204/A/FO-204/A and 205/A/FO-205/A

Step	Action
1	Loosen the nut (9).
2	Completely release the spring (22) by turning the adjusting screw (10).
3	Remove the adjusting screw (10) together with the cap (9).
4	Remove the cap (8).
	Remove the O-ring (38) from the cap (8) and replace it, lubricating it with synthetic grease.
5	 <b>NOTICE!</b> <b>Before inserting the replacement O-ring, clean the retaining slots with a cleaning solution.</b>
6	Remove the spring (22) and the spring supports (7).
7	Undo and remove the screws of the lower section (24).
8	Remove the bracket (14) from the sleeve (6).
9	Remove the sleeve (6).
10	Undo and remove the screws of the upper section (24).
11	Remove the pilot cover (1).
12	<b>ONLY VALID FOR 204/A/FO - 205/A/FO</b> Remove the spacer (47).
13	Remove the spring (20).
14	Unscrew and remove the nut (26).
	Remove the O-ring (26.1) from the nut (26) and replace it, lubricating it with synthetic grease.
15	 <b>NOTICE!</b> <b>Before inserting the replacement O-ring, clean the retaining slots with a cleaning solution.</b>
16	Pull out the "B" (valve) assembly.
	Remove the O-rings (28, 29) from the valve seat (3) and replace them, lubricating them with synthetic grease.
17	 <b>NOTICE!</b> <b>Before inserting the replacement O-ring, clean the retaining slots with a cleaning solution.</b>
18	Remove assembly "A" (plug) from the valve body (4) by pushing it from the top downwards.
19	Unscrew and remove the pilot nut (2).
	Remove the O-ring (18) of the pilot nut (2) and replace it, lubricating it with synthetic grease.
20	 <b>NOTICE!</b> <b>Before inserting the replacement O-ring, clean the retaining slots with a cleaning solution.</b>
21	Remove the spring (21).
22	Remove and replace the plug (17).
23	Remove the upper protection disc (15).
	Remove and replace the upper diaphragm (16), lubricating the lanyards with synthetic grease.
24	 <b>NOTICE!</b> <b>Before inserting the replacement diaphragm, clean the retaining slots with a cleaning solution.</b>



*Pilot 204/A/FO-204/A and 205/A/FO-205/A*

Step	Action
25	Unscrew and remove the nut (25).
26	Remove the lower protection disc (15).
27	Remove and replace the lower diaphragm (16), lubricating the lanyards with synthetic grease. <b>NOTICE!</b> <b>Before inserting the replacement diaphragm, clean the retaining slots with a cleaning solution.</b>
28	Fit the lower protection disc (15).
29	Fix the nut (25) according to the following tightening torque: • Pilot 204/A/FO-204/FO and 205/A/FO-205/A: Tab. 9.105
30	Fit the plug (17) and then the spring (21).
31	Fit the upper protection disc (15).
32	Fix the pilot nut (2) according to the following tightening torque: • Pilot 204/A/FO-204/FO and 205/A/FO-205/A: Tab. 9.105
33	Insert assembly "A" (plug) from top to bottom into the valve body (4). <b>NOTICE!</b> • <b>Take care not to damage the diaphragms (16) during this step</b> • <b>Make sure the marking on the lower section of the headframe is parallel to the axis of the hole for inserting the seat (3) into the valve body (4).</b>
34	Insert assembly "B" (valve) into the valve body (4). <b>NOTICE!</b> <b>Take care not to damage the O-rings (28, 29) and the valve seat (3).</b>
35	Screw in the nut (26) according to the following tightening torque: • Pilot 204/A/FO-204/FO and 205/A/FO-205/A: Tab. 9.105
36	Fit the spring (20).
37	<b>ONLY VALID FOR 204/A/FO - 205/A/FO</b> Insert the spacer (47).
38	Fit the cover (1).
39	Insert and fix the screws of the upper section (24) according to the following tightening torque: • Pilot 204/A/FO-204/FO and 205/A/FO-205/A: Tab. 9.105
40	Fit the sleeve (6) and the bracket (14).
41	Insert and fix the screws of the lower section (24) according to the following tightening torque: • Pilot 204/A/FO-204/FO and 205/A/FO-205/A: Tab. 9.105
42	Fit the spring (22) and the spring supports (7).
43	Unscrew the cap (8).
44	Remove and replace the O-ring (11) in the nut (9). <b>NOTICE!</b> <b>Before inserting the replacement O-ring, clean the retaining slots with a cleaning solution.</b>
45	Fit the adjusting screw (10) together with the cap (9).

Tab. 9.138.

**WARNING!**

**Ensure that all parts have been fitted correctly.**

9.4.6.3 - PILOT 207/A/FO AND 207/A

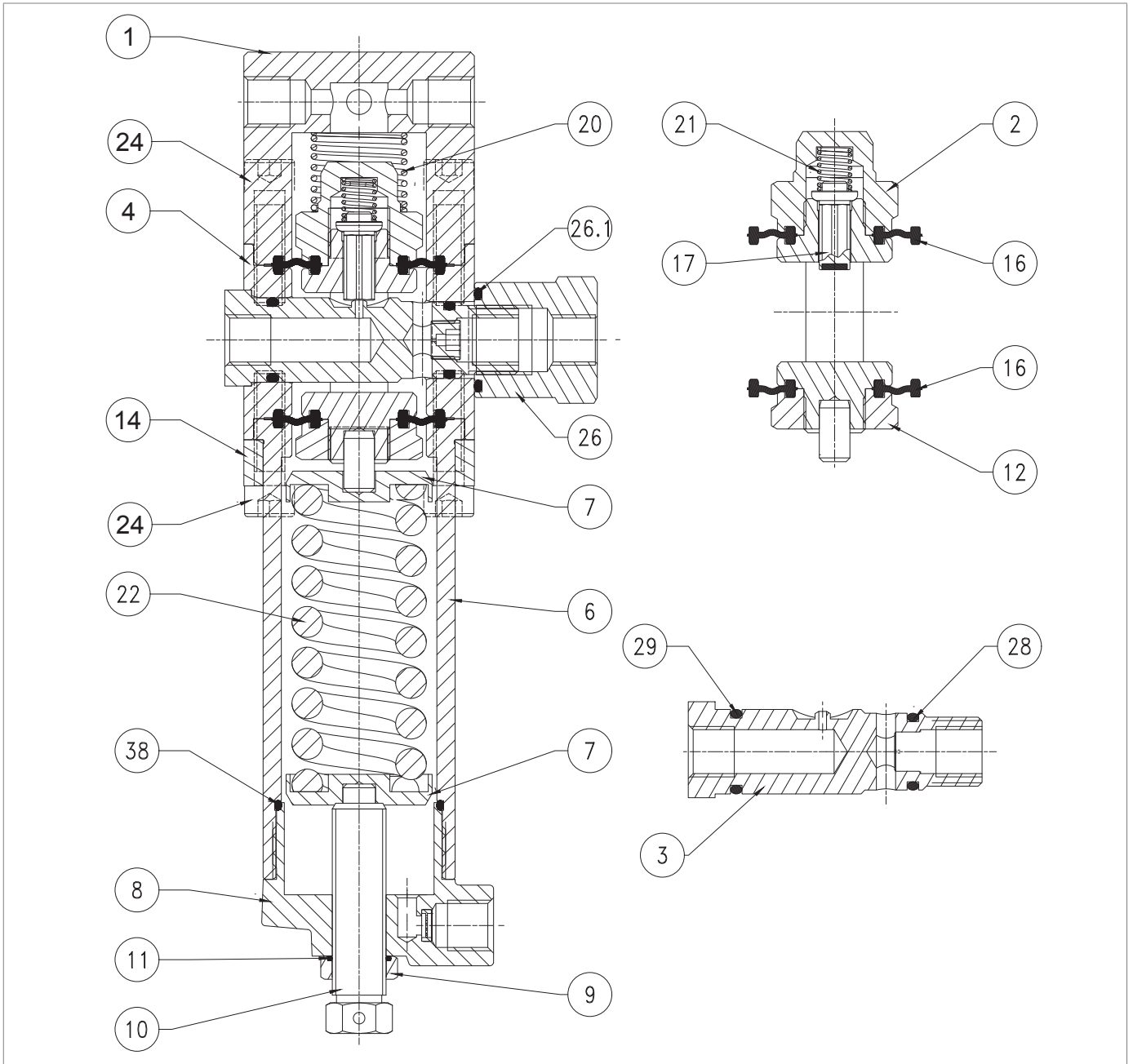



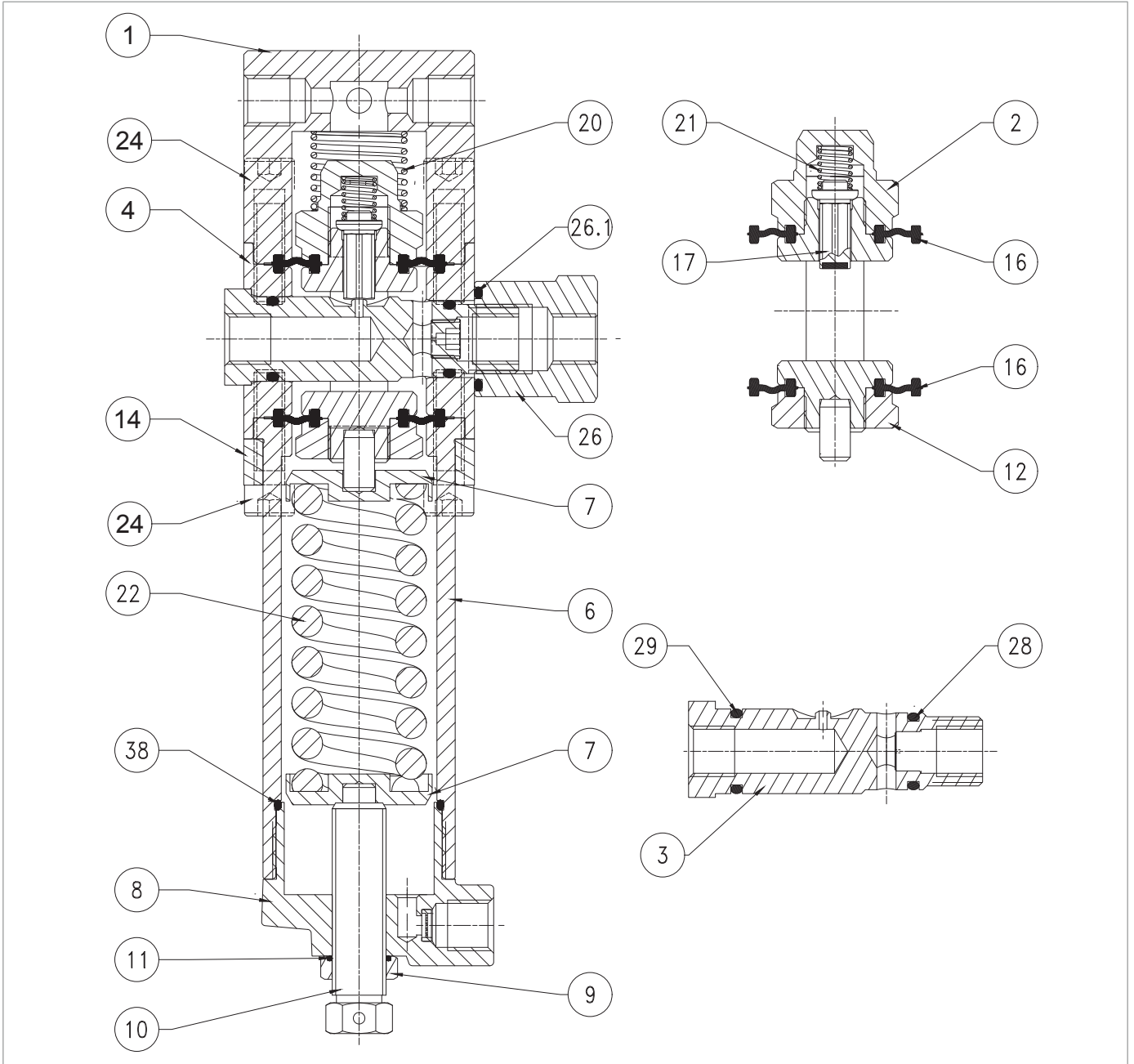

Fig. 9.66. Pilot 207/A/FO and 207/A

Step	Action
1	Loosen the nut (9).
2	Completely release the spring (22) by turning the adjusting screw (10).
3	Remove the adjusting screw (10) together with the cap (9).
4	Remove the cap (8).
	Remove the O-ring (38) from the cap (8) and replace it, lubricating it with synthetic grease.
5	<div style="border: 1px solid black; padding: 5px;">  <b>NOTICE!</b>  <b>Before inserting the replacement O-ring, clean the retaining slots with a cleaning solution.</b> </div>
6	Remove the spring (22) and the spring supports (7).
7	Undo and remove the screws of the lower section (24).
8	Remove the bracket (14) from the sleeve (6).
9	Remove the sleeve (6).
10	Undo and remove the screws of the upper section (24).
11	Remove the pilot cover (1).
12	<b>ONLY VALID FOR 207/A/FO</b> Remove the spacer (47).
13	Remove the spring (20).
14	Unscrew and remove the nut (26).
	Remove the O-ring (26.1) from the nut (26) and replace it, lubricating it with synthetic grease.
15	<div style="border: 1px solid black; padding: 5px;">  <b>NOTICE!</b>  <b>Before inserting the replacement O-ring, clean the retaining slots with a cleaning solution.</b> </div>
16	Unscrew and remove the pilot nut (2).
17	Remove the spring (21).
18	Remove and replace the plug (17).
19	Remove and replace the upper diaphragm (16).
20	Pull out the "B" (valve) assembly.
	Remove the O-rings (28, 29) from the valve seat (3) and replace them, lubricating them with synthetic grease.
21	<div style="border: 1px solid black; padding: 5px;">  <b>NOTICE!</b>  <b>Before inserting the replacement O-rings, clean the retaining slots with a cleaning solution.</b> </div>
22	Remove assembly "A" (plug) from the valve body (4) by pushing it from the top downwards.
23	Unscrew and remove the nut (12).
	Remove and replace the lower diaphragm (16), lubricating the lanyards with synthetic grease.
24	<div style="border: 1px solid black; padding: 5px;">  <b>NOTICE!</b>  <b>Before inserting the replacement diaphragm, clean the retaining slots with a cleaning solution.</b> </div>
25	Place and fix the nut (12) according to the following tightening torque: <ul style="list-style-type: none"> <li>Pilot 207/A/FO-207/A: Tab. 9.106</li> </ul>



*Pilot 207/A/FO and 207/A*

Step	Action
26	Insert assembly "A" (plug) from top to bottom into the valve body (4). <div style="border: 1px solid black; padding: 5px;">  <b>NOTICE!</b>  <ul style="list-style-type: none"> <li>• <b>Take care not to damage the diaphragms (16) during this step.</b></li> <li>• <b>Make sure the marking on the lower section of the headframe is parallel to the axis of the hole for inserting the seat (3) into the valve body (4).</b></li> </ul> </div>
27	Insert assembly "B" (valve) into the valve body (4). <div style="border: 1px solid black; padding: 5px;">  <b>NOTICE!</b>  <b>Take care not to damage the O-rings (28, 29) and the valve seat (3).</b> </div>
28	Screw in the nut (26) according to the following tightening torque: <ul style="list-style-type: none"> <li>• Pilot 207/A/FO-207/A: Tab. 9.106</li> </ul>
29	Put the upper diaphragm (16) back in place, lubricating the lanyards with synthetic grease. <div style="border: 1px solid black; padding: 5px;">  <b>NOTICE!</b>  <b>Before inserting the replacement diaphragm, clean the retaining slots with a cleaning solution.</b> </div>
30	Put the plug (17) and then the spring (21) back in place.
31	Refit and fix the pilot nut (2) according to the following tightening torque: <ul style="list-style-type: none"> <li>• Pilot 207/A/FO-207/A: Tab. 9.106</li> </ul>
32	Fit the spring (20).
33	<b>ONLY VALID FOR 207/A/FO</b> Insert the spacer (47).
34	Fit the cover (1).
35	Insert and fix the screws of the upper section (24) according to the following tightening torque: <ul style="list-style-type: none"> <li>• Pilot 207/A/FO-207/A: Tab. 9.106</li> </ul>
36	Fit the sleeve (6) and the bracket (14).
37	Insert and fix the screws of the lower section (24) according to the following tightening torque: <ul style="list-style-type: none"> <li>• Pilot 207/A/FO-207/A: Tab. 9.106</li> </ul>
38	Fit the spring (22) and the spring supports (7).
39	Unscrew the cap (8).
40	Remove and replace the O-ring (11) in the nut (9). <div style="border: 1px solid black; padding: 5px;">  <b>NOTICE!</b>  <b>Before inserting the replacement O-ring, clean the retaining slots with a cleaning solution.</b> </div>
41	Fit the adjusting screw (10) together with the cap (9).

Tab. 9.139.

 **WARNING!**

**Ensure that all parts have been fitted correctly.**

9.4.6.4 - R14/A/FO PRE-REGULATOR

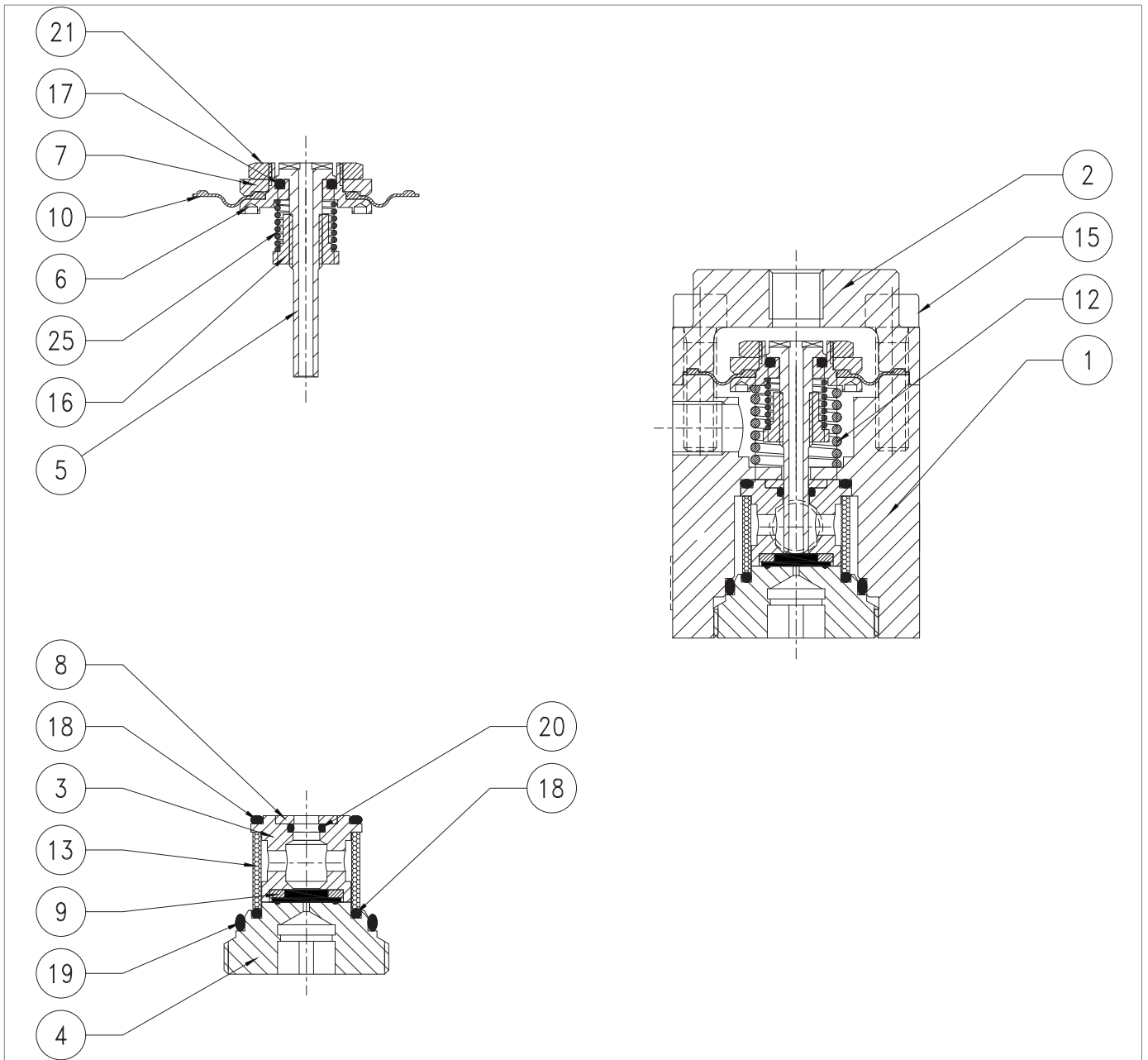
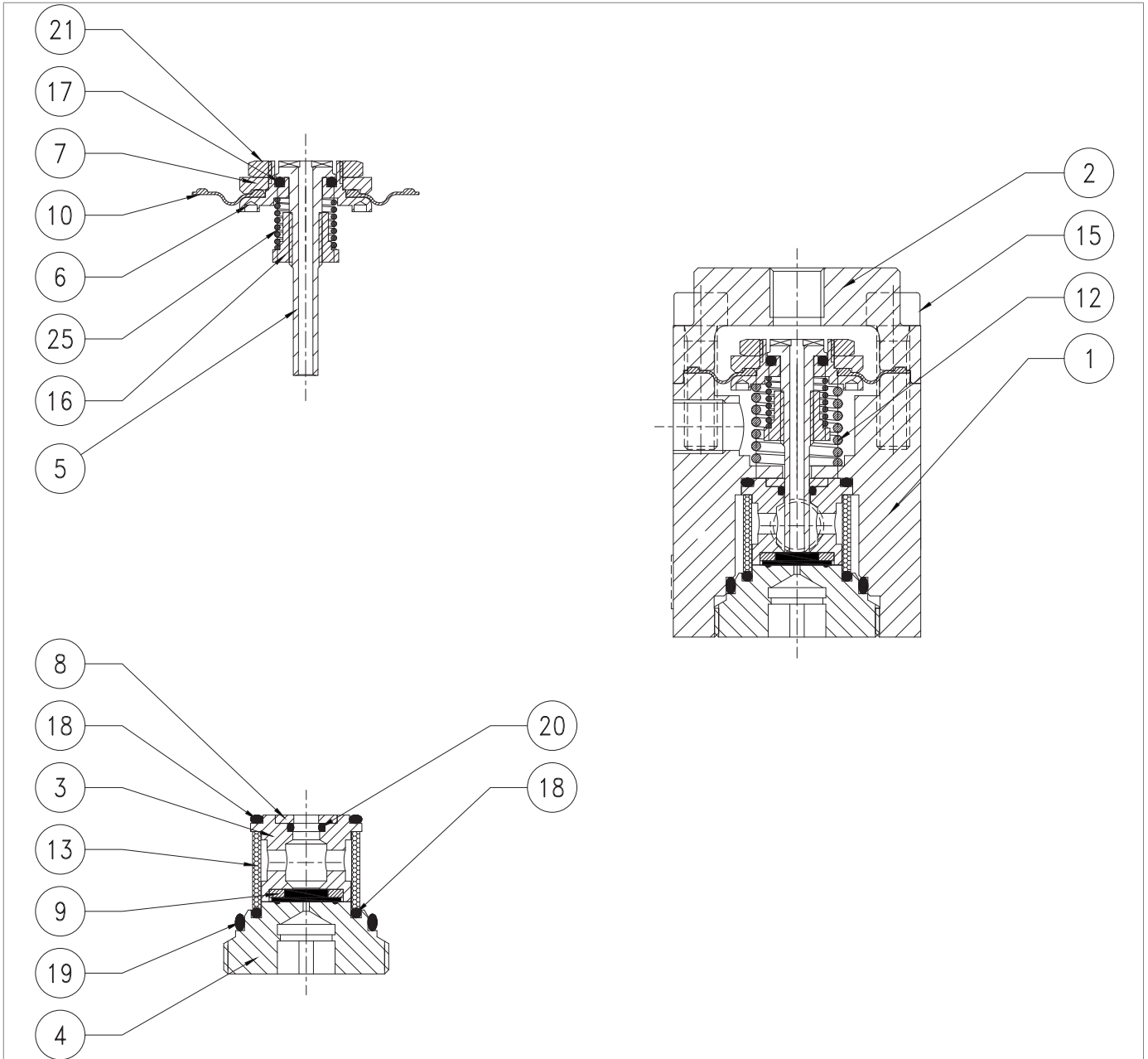





Fig. 9.67. R14/A/FO Pre-regulator

Step	Action
1	Undo and remove the screws (15).
2	Remove the cover (2)
3	Pull out the "A" (plug) assembly.
4	Remove the spring (12).
5	Unscrew and remove the nut (16).
6	Remove the spring (25).
7	Remove the plug (5).
8	Remove and replace the O-ring (17) from the diaphragm protection disc (6), lubricating it with synthetic grease. <b>NOTICE!</b> <b>Before inserting the replacement O-ring, clean the retaining slots with a cleaning solution.</b>
9	Unscrew and remove the nut (21).
10	Remove the diaphragm protection disc (7).
11	Remove and replace the gasket (10).
12	Fit the diaphragm protection disc (7).
13	Insert and fix the nut (21)
14	Fit the plug (5). <b>NOTICE!</b> <b>Take care not to damage the plug profile (5).</b>
15	Insert the spring (25).
16	Insert and fasten the nut (16) by hand.
17	Unscrew and remove assembly "B" (cap) by adjusting the cap (4).
18	Take out the plug guide (3).
19	Remove the O-ring (18) from the plug guide (3) and replace it, lubricating it with synthetic grease. <b>NOTICE!</b> <b>Before inserting the replacement O-ring, clean the retaining slots with a cleaning solution.</b>
20	Remove the ring (8).
21	Remove the O-ring (20) from the plug guide (3) and replace it, lubricating it with synthetic grease. <b>NOTICE!</b> <b>Before inserting the replacement O-ring, clean the retaining slots with a cleaning solution.</b>
22	Remove and replace the reinforced gasket (9). <b>NOTICE!</b> <b>Before inserting the replacement O-ring, clean the retaining slots with a cleaning solution.</b>
23	Remove and replace the filter (13).



R14/A/FO Pre-regulator

Step	Action
24	Remove the O-rings (18, 19) from the cap (4) and replace them, lubricating them with synthetic grease. <div style="border: 1px solid black; padding: 5px;">  <b>NOTICE!</b>  <b>Before inserting the replacement O-rings, clean the retaining slots with a cleaning solution.</b> </div>
25	Put the filter (13) and the plug guide (3) in place.
26	Position the ring (8).
27	Position and secure the "B" assembly (cap). <div style="border: 1px solid black; padding: 5px;">  <b>NOTICE!</b>  <b>Take care not to damage the O-rings (18, 19) during this step.</b> </div>
28	Fit the spring (12).
29	Insert assembly "A" (plug) into the body (1). <div style="border: 1px solid black; padding: 5px;">  <b>NOTICE!</b>  <b>Before inserting the plug unit, lubricate the plug surface with silicone grease.</b> </div>
30	Fit the cover (2).
31	Insert and fix the screws (15) according to the following tightening torque: <ul style="list-style-type: none"> <li>• R14/A/FO: Tab. 9.107.</li> </ul> <div style="border: 1px solid black; padding: 5px;">  <b>NOTICE!</b>  <b>Tighten the screws according to the cross diagram in paragraph 9.4.2.2.</b> </div>

Tab. 9.140.

 **WARNING!**

**Ensure that all parts have been fitted correctly.**

9.4.6.5 - PRE-REGULATOR R14/A

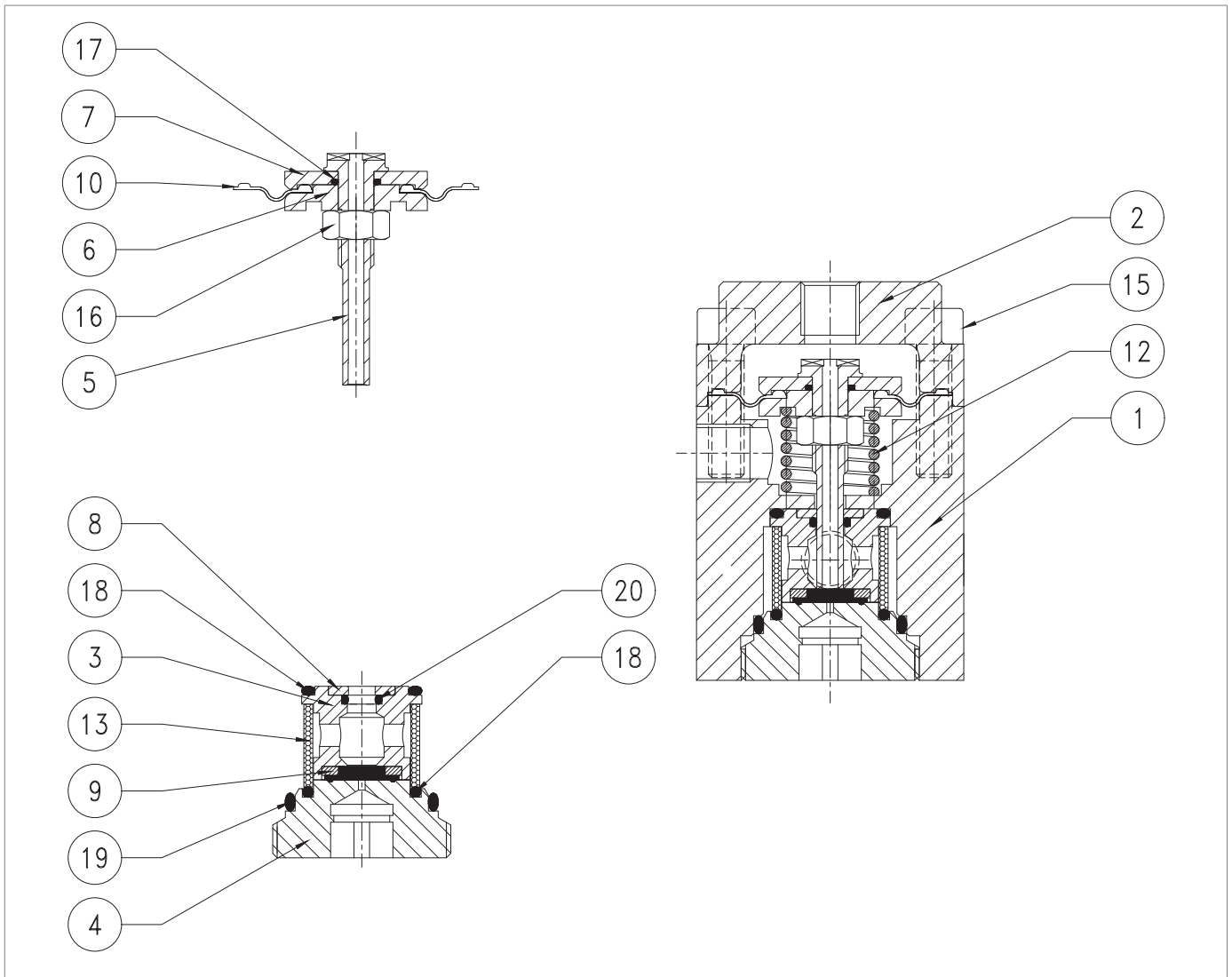





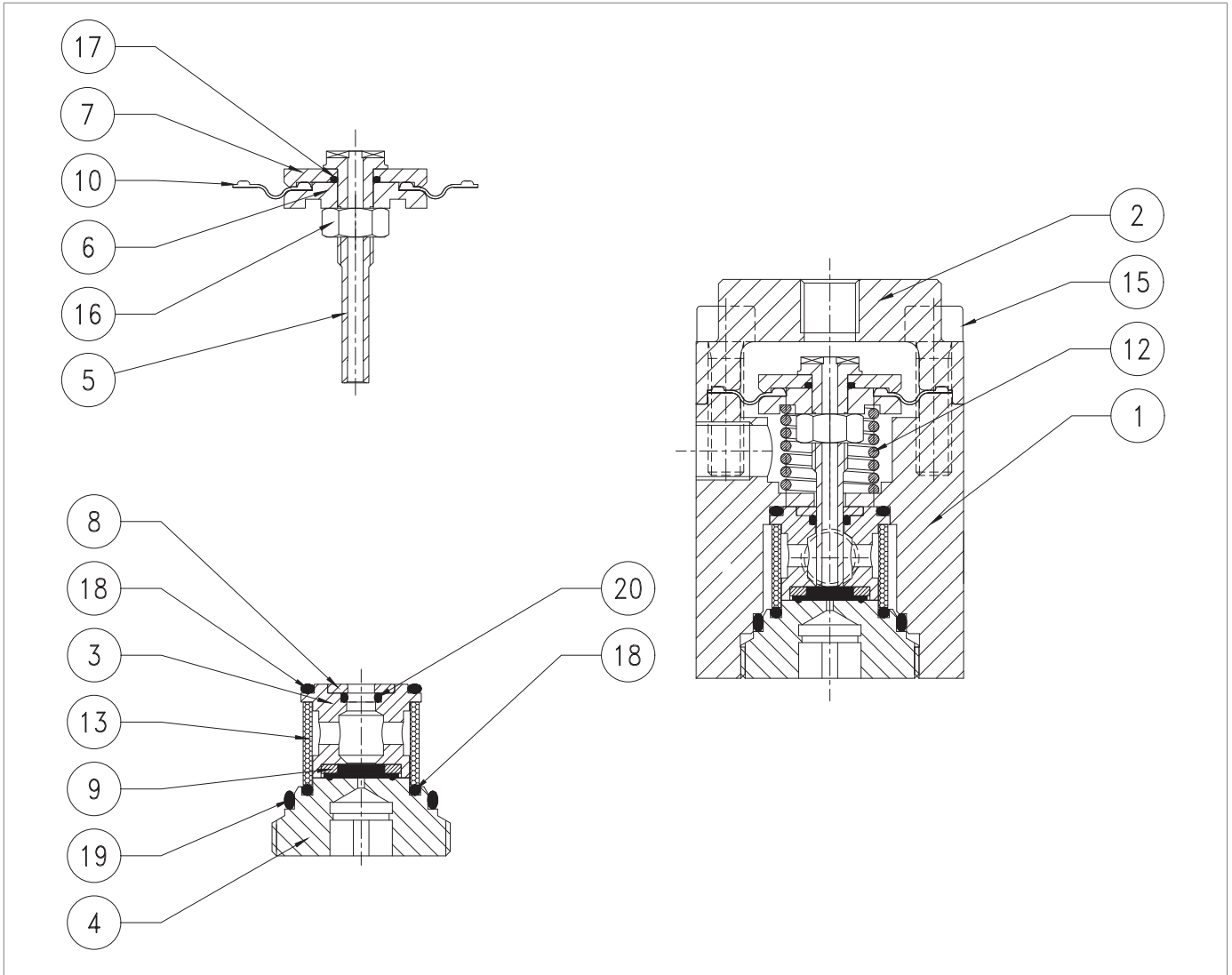





Fig. 9.68. Pre-regulator R14/A

Step	Action
1	Undo and remove the screws (15).
2	Remove the cover (2)
3	Pull out the "A" (plug) assembly.
4	Remove the spring (12).
5	Unscrew and remove the nut (16).
6	Insert the diaphragm protection disc (6) and the diaphragm (10).
7	Remove and replace the O-ring (17) from the diaphragm protection disc (7), lubricating it with synthetic grease. <div style="border: 1px solid black; padding: 5px;">  <b>NOTICE!</b>  <b>Before inserting the replacement O-ring, clean the retaining slots with a cleaning solution.</b> </div>
8	Remove and replace the gasket (10). <div style="border: 1px solid black; padding: 5px;">  <b>NOTICE!</b>  <b>Before inserting the replacement diaphragm, clean the retaining slots with a cleaning solution.</b> </div>
9	Fit the diaphragm protection disc (7).
10	Fit and fix the nut (16) into the plug (5) according to the following tightening torque: <ul style="list-style-type: none"> <li>R14/A: Tab. 9.107</li> </ul>
11	Unscrew and remove assembly "B" (cap) by adjusting the cap (4).
12	Take out the plug guide (3).
13	Remove the O-ring (18) from the plug guide (3) and replace it, lubricating it with synthetic grease. <div style="border: 1px solid black; padding: 5px;">  <b>NOTICE!</b>  <b>Before inserting the replacement O-ring, clean the retaining slots with a cleaning solution.</b> </div>
14	Remove the ring (8).
15	Remove the O-ring (20) from the plug guide (3) and replace it, lubricating it with synthetic grease. <div style="border: 1px solid black; padding: 5px;">  <b>NOTICE!</b>  <b>Before inserting the replacement O-ring, clean the retaining slots with a cleaning solution.</b> </div>
16	Remove and replace the reinforced gasket (9). <div style="border: 1px solid black; padding: 5px;">  <b>NOTICE!</b>  <b>Before inserting the replacement O-ring, clean the retaining slots with a cleaning solution.</b> </div>
17	Remove and replace the filter (13).
18	Remove the O-rings (18, 19) from the cap (4) and replace them, lubricating them with synthetic grease. <div style="border: 1px solid black; padding: 5px;">  <b>NOTICE!</b>  <b>Before inserting the replacement O-rings, clean the retaining slots with a cleaning solution.</b> </div>
19	Put the filter (13) and the plug guide (3) in place.
20	Position the ring (8).



*Pre-regulator R14/A*

Step	Action
21	Position and secure the "B" assembly (cap). <div style="border: 1px solid blue; padding: 5px;">  <b>NOTICE!</b>  <b>Take care not to damage the O-rings (18, 19) during this step.</b> </div>
22	Fit the spring (12).
23	Insert assembly "A" (plug) into the body (1). <div style="border: 1px solid blue; padding: 5px;">  <b>NOTICE!</b>  <b>Before inserting the plug unit, lubricate the plug surface with silicone grease.</b> </div>
24	Fit the cover (2).
25	Insert and fix the screws (15) according to the following tightening torque: <ul style="list-style-type: none"> <li>R14/A: Tab. 9.107</li> </ul> <div style="border: 1px solid blue; padding: 5px;">  <b>NOTICE!</b>  <b>Tighten the screws as shown in the diagram at "9.4.2.2 - Cross diagram for tightening screws".</b> </div>

Tab. 9.141

 **WARNING!**

**Ensure that all parts have been fitted correctly.**



To connect the 200/A/FO series pilot, proceed as in Tab. 9.142:

Step	Action
1	Insert and fasten the screw (7) to the pilot 200/A/FO.
2	Insert and fasten the screw (6) to connect the R14/A/FO pre-regulator to the 200/A/FO pilot.
3	Connect the pipe (20) by adjusting the fittings (4, 5).
4	Insert and fix the fixing screw to connect the pilot to the regulator.
5	Connect the sensing lines between the pilot and the regulator by adjusting the fittings (2, 3, 8, 9).

*Tab. 9.142.*

To disconnect the 200/A series pilot, proceed as in Tab. 9.143:

Step	Action
1	Insert and fix the screw (7) to the 200/A pilot.
2	Insert and fasten the screw (6) to connect the R14/A pre-regulator to the 200/A pilot.
3	Connect the pipe (20) by adjusting the fittings (4, 5).
4	Insert and fix the fixing screw to connect the pilot to the regulator.
5	Connect the sensing lines between the pilot and the regulator by adjusting the fittings (1, 2, 3).

*Tab. 9.143.*

**9.4.7 - M/A ACCELERATOR VALVE MAINTENANCE PROCEDURE**

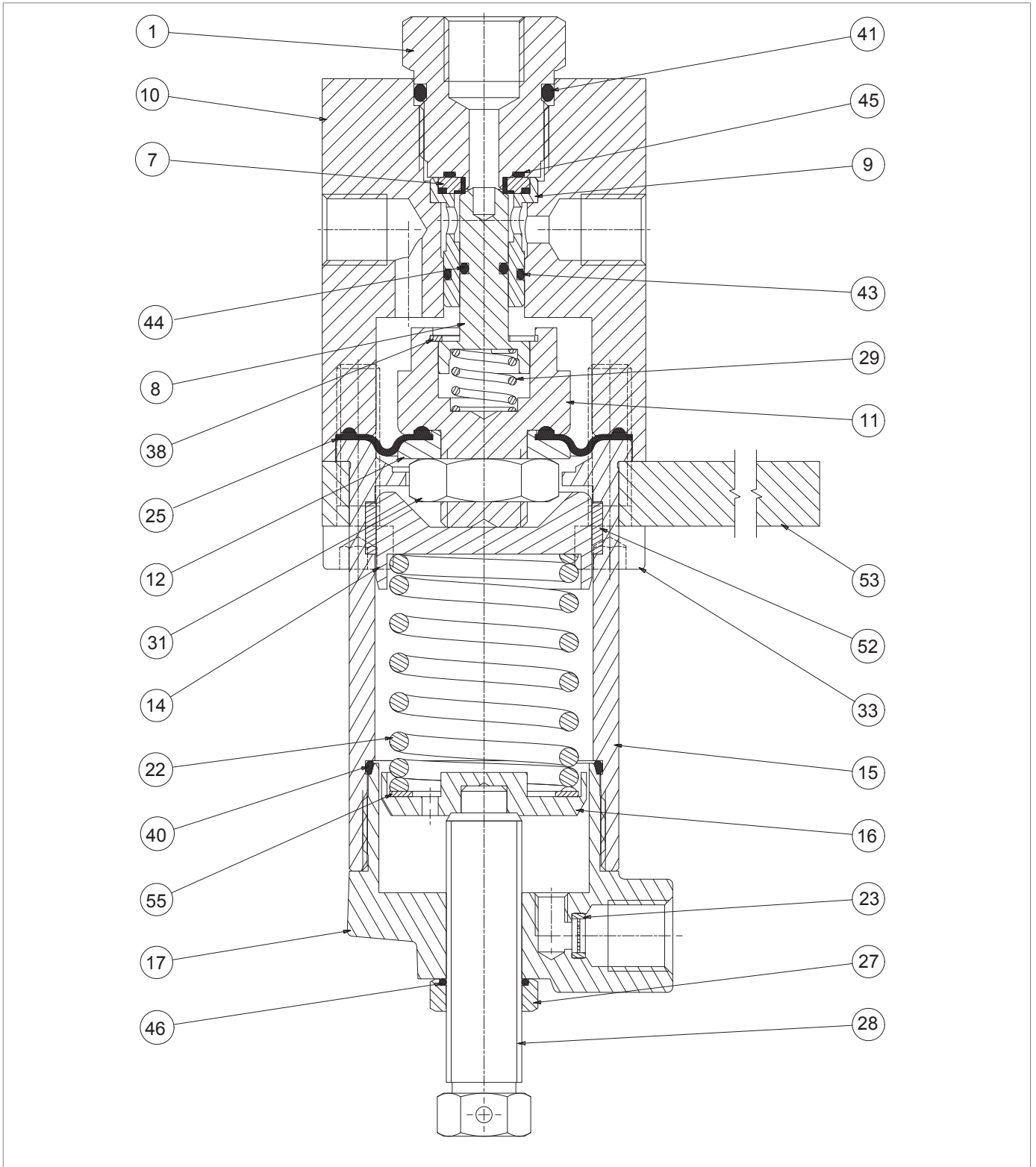





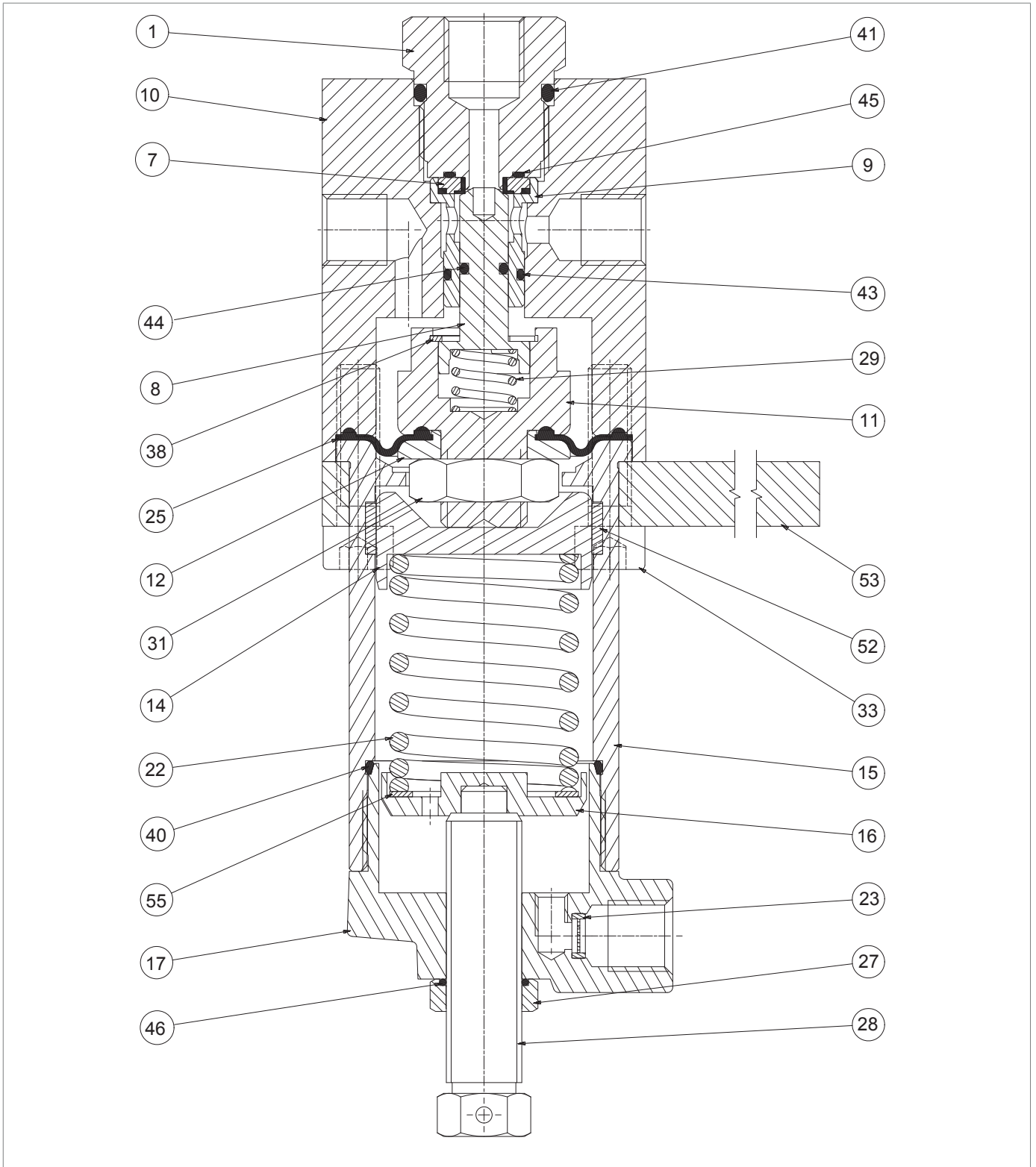





Fig. 9.70. M/A accelerating valve

Step	Action
1	Loosen the nut (27).
2	Completely release the spring (22) by turning the adjusting screw (28).
3	Remove the adjusting screw (28) together with the nut (27).
4	Remove the cap (17).
	Remove the O-ring (40) from the cap (17) and replace it, lubricating it with synthetic grease.
5	 <b>NOTICE!</b> <b>Before inserting the replacement O-ring, clean the retaining slots with a cleaning solution.</b>
6	Remove the lower spring support (16) together with the ring (55).
7	Remove the spring (22).
8	Remove the upper spring support (14).
9	Undo and remove the screws of the lower section (33).
10	Remove the bracket (53) from the sleeve (15).
11	Remove the sleeve (15).
	Remove and replace the I/DWR (52) from the sleeve (15).
12	 <b>NOTICE!</b> <b>Before inserting the replacement I/DWR, clean the retaining slots with a cleaning solution.</b>
13	Take out the diaphragm/plug unit (8,11,12, 25, 29, 31).
14	Unscrew and remove the nut (31).
15	Remove the diaphragm protection disc (12).
	Remove and replace the diaphragm (25).
16	 <b>NOTICE!</b> <b>Before inserting the replacement diaphragm, clean the retaining slots with a cleaning solution.</b>
17	Put the diaphragm protection disc (12) back in place.
18	Refit and secure the nut (31).
	Remove the O-ring (44) from the plug (8) and replace it, lubricating it with synthetic grease.
19	 <b>NOTICE!</b> <b>Before inserting the replacement O-ring, clean the retaining slots with a cleaning solution.</b>
20	Unscrew and remove the gasket support (1).
	Remove the O-rings (41, 45) from the gasket support (1) and replace them, lubricating them with synthetic grease.
21	 <b>NOTICE!</b> <b>Before inserting the replacement O-rings, clean the retaining slots with a cleaning solution.</b>
22	Take out the plug guide (9).
23	Remove and replace the reinforced gasket (7) from the plug guide (9).



*M/A accelerating valve*

Step	Action
24	Remove the O-ring (43) from the plug guide (9) and replace it, lubricating it with synthetic grease. <div style="border: 1px solid black; padding: 2px;">  <b>NOTICE!</b>  <b>Before inserting the replacement O-ring, clean the retaining slots with a cleaning solution.</b> </div>
25	Fit the plug guide (9) together with the reinforced gasket (7).
26	Place the gasket support (1) in the body (10).
27	Take out the diaphragm/plug unit (8, 11, 12, 25, 29, 31). <div style="border: 1px solid black; padding: 2px;">  <b>NOTICE!</b>  <b>Before inserting the diaphragm/plug unit, lubricate the plug (8) surface with silicone grease.</b> </div>
28	Fit the sleeve (15) and the bracket (53).
29	Insert and fix the screws (33). <div style="border: 1px solid black; padding: 2px;">  <b>NOTICE!</b>  <b>Tighten the screws as shown in the diagram at “9.4.2.2 - Cross diagram for tightening screws”.</b> </div>
30	Position the upper spring support (14) together with the spring (22).
31	Fit the lower spring support (16) together with the ring (55).
32	Fit and secure the cap (17).
33	Remove and replace the O-ring (46) in the nut (27). <div style="border: 1px solid black; padding: 2px;">  <b>NOTICE!</b>  <b>Before inserting the replacement O-ring, clean the retaining slots with a cleaning solution.</b> </div>
34	Fit the adjusting screw (28) together with the nut (27).

Tab. 9.144

 **WARNING!**

**Ensure that all parts have been fitted correctly.**

**9.4.8 - SB/82 INCORPORATED SLAM-SHUT VALVE MAINTENANCE PROCEDURE**

**9.4.8.1 - SB/82 1" BUILT-IN SLAM-SHUT VALVE**

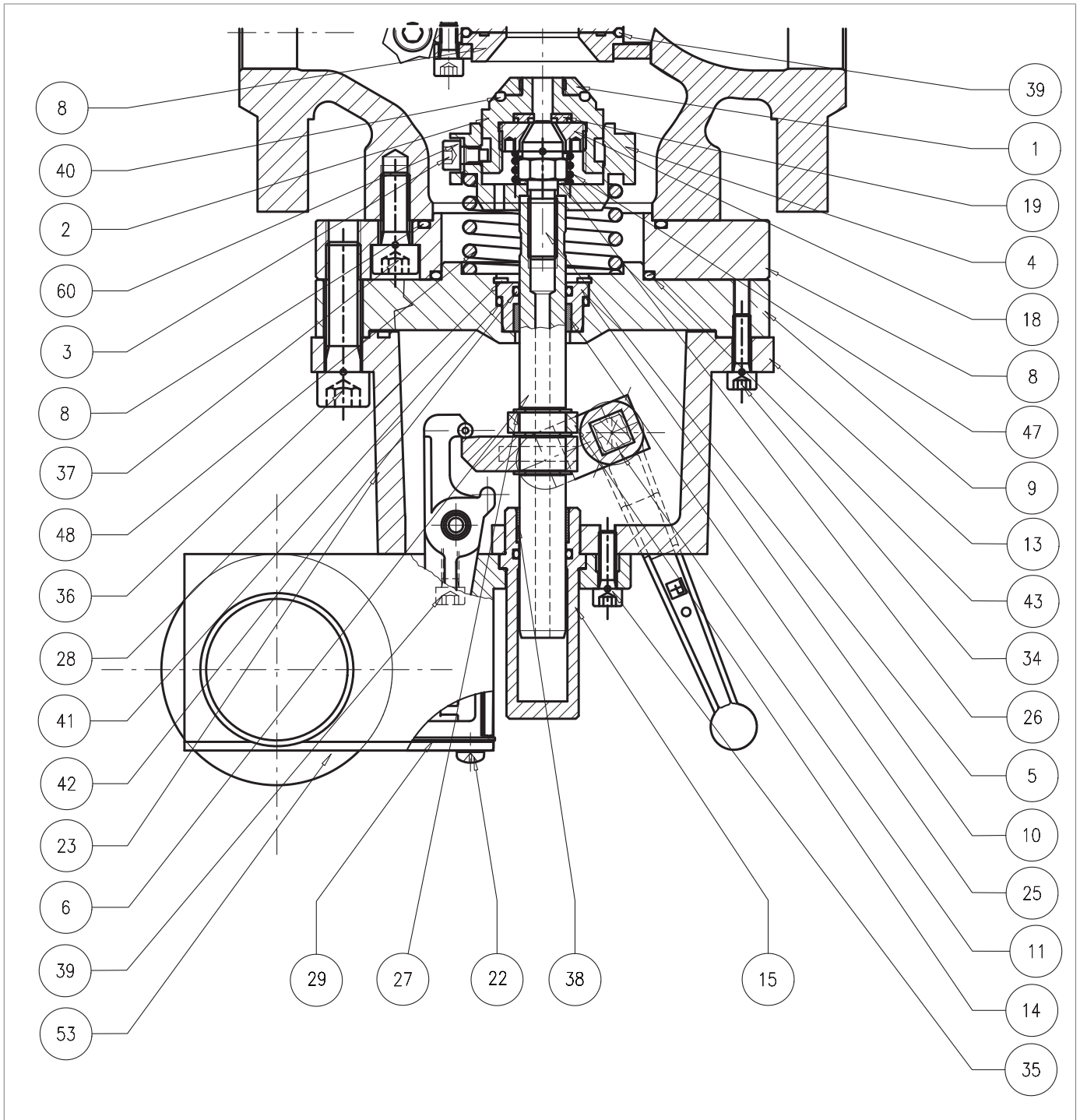

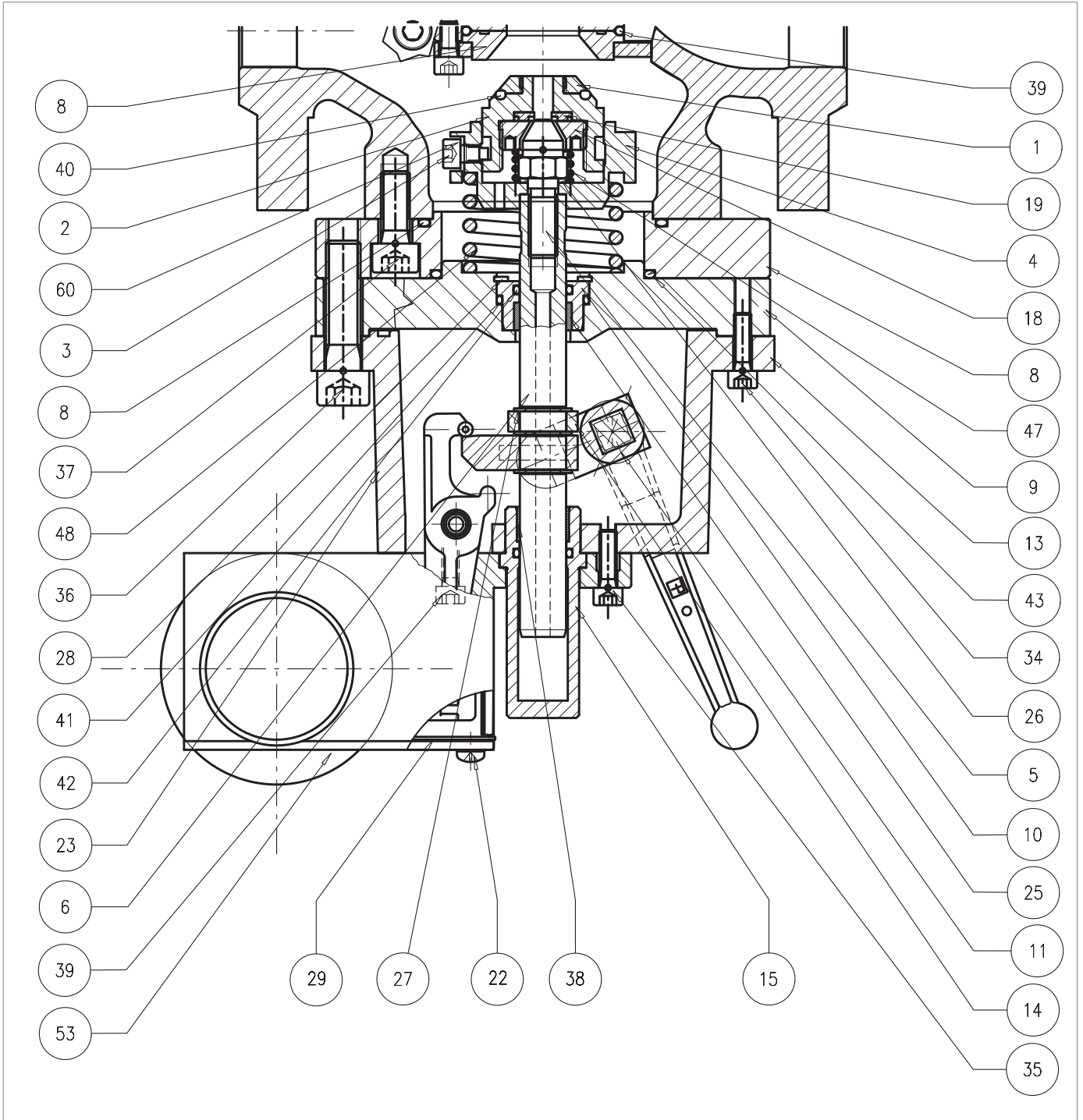

Fig. 9.71. SB/82 1" built-in slam-shut valve

Step	Action
1	 <b>WARNING!</b> <b>Check that the slam-shut valve is in the shut-off position.</b>
2	Unscrew the minimum spring (Fig. 8.34, ref. 17).  <b>NOTICE!</b> <b>Check that the minimum spring is present.</b>
3	Arm the slam-shut valve by moving the reset lever (16) to the 'OPEN' position.
4	 <b>WARNING!</b> <b>Partially unscrew all screws before removing the first one to allow the spring to stretch.</b>
5	Remove the slam-shut valve and place it on an impact-resistant surface with the plug (2) facing downwards.  <b>NOTICE!</b> <b>Take care not to press the reset button (see fig. 4.10, ref. 10).</b>
6	Disarm the slam-shut valve by pressing the reset button (fig. 4.10, ref. 10).  <b>NOTICE!</b> <ul style="list-style-type: none"> <li>• <b>During this phase, slowly move the reset lever (16) to the 'CLOSED' position</b></li> <li>• <b>Take care not to damage the plug (2)</b></li> </ul>
7	Undo the screws (137).
8	Remove the flange (8).
9	Remove the O-ring (43) from the flange (8) and replace it, taking care to lubricate it with synthetic grease.  <b>NOTICE!</b> <b>Before inserting the replacement O-ring, clean the retaining slots with a cleaning solution.</b>
10	Remove the O-ring (37) from the flange (8) and replace it, taking care to lubricate it with synthetic grease.  <b>NOTICE!</b> <b>Before inserting the replacement O-ring, clean the retaining slots with a cleaning solution.</b>
11	Undo and remove the screws (3).
12	Undo and remove the toothed washers (60).
13	Take out the plug unit.
14	Remove the spring (47).
15	Unscrew and remove the ring nut (18) with the appropriate tool.  <b>NOTICE!</b> <b>Please refer to “Tab. 7.57” at “7.1 - List of equipment”.</b>
16	Remove and replace the pad (19).
17	Fit and fix the ring nut (18) with the appropriate tool.  <b>NOTICE!</b> <b>Please refer to “Tab. 7.57” at “7.1 - List of equipment”.</b>
18	Unscrew and remove the ring nut (1).



*SB/82 1" built-in slam-shut valve*

Step	Action
19	Remove the O-ring (40) from the plug (2) and replace it, taking care to lubricate it with synthetic grease. <div style="border: 1px solid black; padding: 5px;"><b>! NOTICE!</b>  <b>Before inserting the replacement O-ring, clean the retaining slots with a cleaning solution.</b></div>
20	Refit and secure the ring nut (1).
21	Undo the plug screw (5).
22	Remove the washer (26).
23	Remove the spring (48) and the spring support (4).
24	Undo and remove the screws (22) of the pressure switch.
25	Remove the cover (119) together with the gasket (29).
26	Undo the side screws (39) inside the box.
27	Undo the screws (35).
28	Take out the pressure switch unit. <div style="border: 1px solid black; padding: 5px;"><b>! NOTICE!</b>  <b>For the maintenance procedure of the pressure switch unit, refer to the relative table.</b></div>
29	Remove the cup (15).
30	Remove the O-ring (42) from the cup (15) and replace it, taking care to lubricate it with synthetic grease. <div style="border: 1px solid black; padding: 5px;"><b>! NOTICE!</b>  <b>Before inserting the replacement O-ring, clean the retaining slots with a cleaning solution.</b></div>
31	Undo and remove the screws (34).
32	Remove the intermediate body (13) from the flange (9).
33	Extract the stem (6) taking care not to damage it.
34	Remove the Seeger ring (28) from the flange (9).
35	Remove the bush (10).
36	Remove the O-ring (41) from the bush (10) and replace it, lubricating it with synthetic grease. <div style="border: 1px solid black; padding: 5px;"><b>! NOTICE!</b>  <b>Before inserting the replacement O-ring, clean the retaining slots with a cleaning solution.</b></div>
37	Remove the I/DWR ring (25) from the bush (10) and replace it, taking care to lubricate it with synthetic grease. <div style="border: 1px solid black; padding: 5px;"><b>! NOTICE!</b>  <b>Before inserting the replacement I/DWR ring, clean the retaining slots with a cleaning solution.</b></div>
38	Fit the bush (10). <div style="border: 1px solid black; padding: 5px;"><b>! NOTICE!</b>  <b>Take care not to damage the O-ring (41).</b></div>
39	Fit the Seeger ring (28).
40	Fit the stem (6). <div style="border: 1px solid black; padding: 5px;"><b>! NOTICE!</b>  <b>Lubricate the stem surface with silicone grease.</b></div>

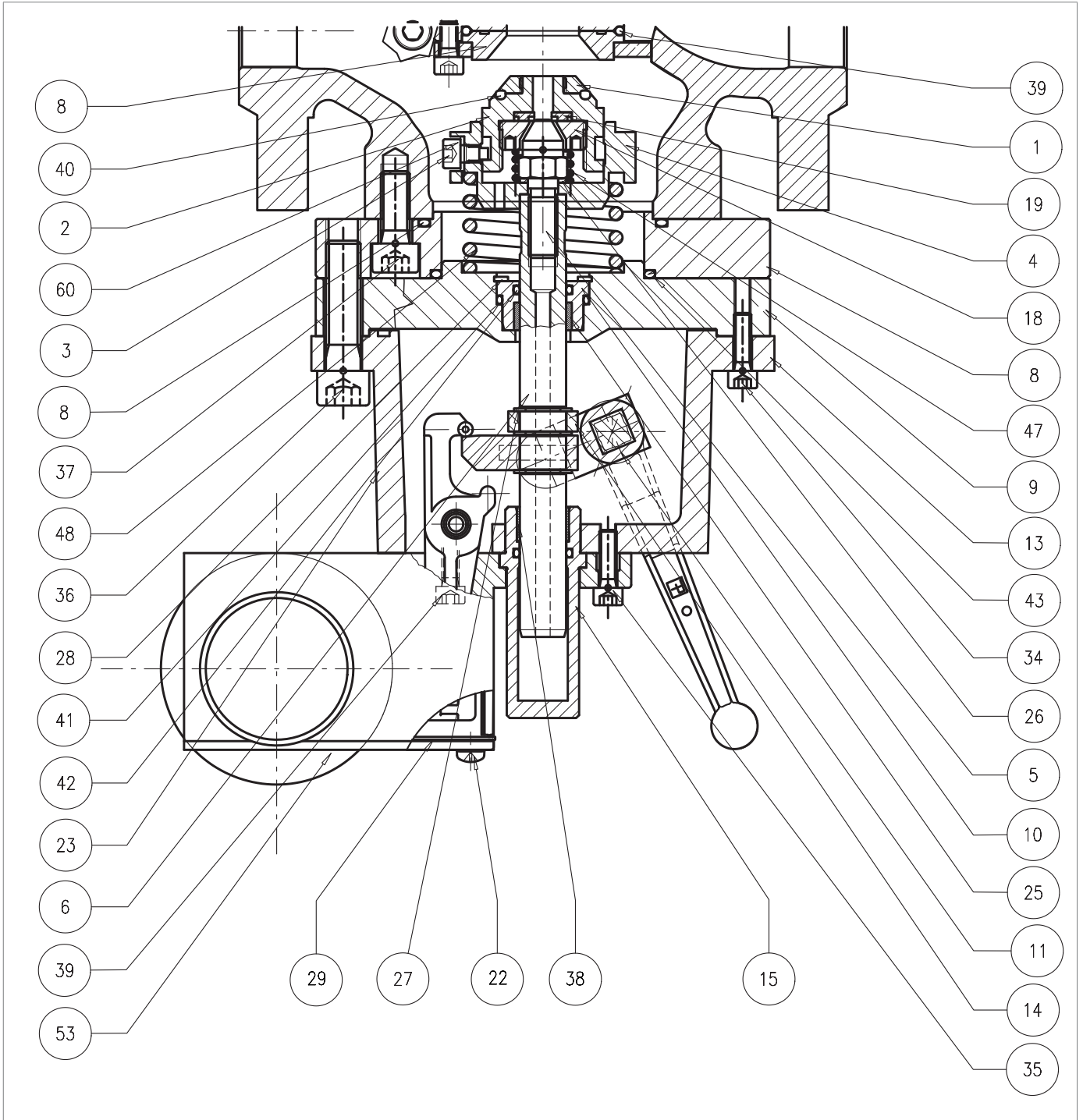

*SB/82 1" built-in slam-shut valve*

Step	Action
41	Fit the intermediate body (13).
42	Fit the cup (15).
43	Fit the pressure switch unit.
44	Insert and fix the screws (35) according to the following tightening torque: <ul style="list-style-type: none"> <li>• 1": Tab. 9.108</li> </ul>
45	Insert and fix the side screws (39) into the pressure switch according to the following tightening torque: <ul style="list-style-type: none"> <li>• 1": Tab. 9.108</li> </ul>
46	Fit the gasket (29) and the cover (119).
47	Insert and fix the screws (22).
48	Put the spring (48) and spring support (4) in place.
49	Fit the washer (26) <div style="border: 1px solid black; padding: 5px; margin-top: 5px;">  <b>NOTICE!</b>  <b>Before inserting the screw (5), apply thread locking glue.</b> </div>
50	Fix the plug screw (5).
51	Fit the spring (47).
52	Fit the plug unit.
53	Insert the serrated washers (60). <div style="border: 1px solid black; padding: 5px; margin-top: 5px;">  <b>NOTICE!</b>  <b>Before inserting the screw (3), apply thread locking glue.</b> </div>
54	Insert and fix the screws (3) according to the following tightening torque <ul style="list-style-type: none"> <li>• 1": Tab. 9.108</li> </ul> <div style="border: 1px solid black; padding: 5px; margin-top: 5px;">  <b>NOTICE!</b>  <b>Tighten the screws as shown in the diagram at "9.4.2.2 - Cross diagram for tightening screws".</b> </div>
55	Fit the flange (8) on the body.
56	Fix the screws (137) according to the following tightening torque <ul style="list-style-type: none"> <li>• 1": Tab. 9.108</li> </ul> <div style="border: 1px solid black; padding: 5px; margin-top: 5px;">  <b>NOTICE!</b>  <b>Tighten the screws as shown in the diagram at "9.4.2.2 - Cross diagram for tightening screws".</b> </div>
57	Turn the slam-shut valve upside down with the plug (2) facing downwards on an impact-resistant surface.
58	Arm the slam-shut valve by moving the reset lever (16) to the opening position
59	Position the slam-shut valve. <div style="border: 1px solid black; padding: 5px; margin-top: 5px;">  <b>NOTICE!</b>  <b>Take care not to press the reset button (see fig. 4.10, ref. 10).</b> </div>
60	Insert and fix the screws (36) according to the following tightening torque <ul style="list-style-type: none"> <li>• 1": Tab. 9.108</li> </ul> <div style="border: 1px solid black; padding: 5px; margin-top: 5px;">  <b>NOTICE!</b>  <b>Tighten the screws as shown in the diagram at "9.4.2.2 - Cross diagram for tightening screws".</b> </div>

Tab. 9.145

 **WARNING!**

**Ensure that all parts have been fitted correctly.**

**9.4.8.2 - INCORPORATED SLAM-SHUT VALVE SB/82 2" - 3"**

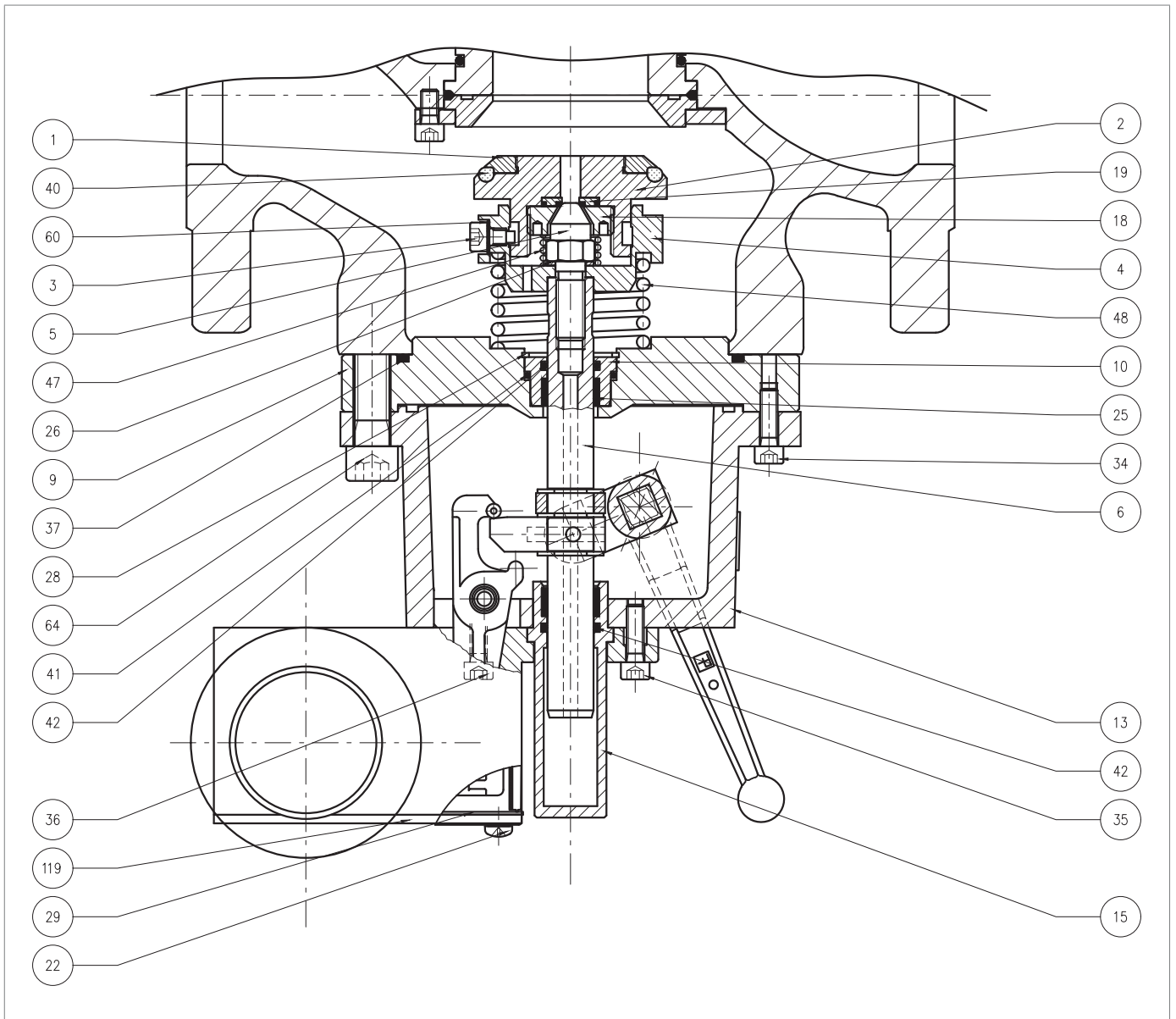
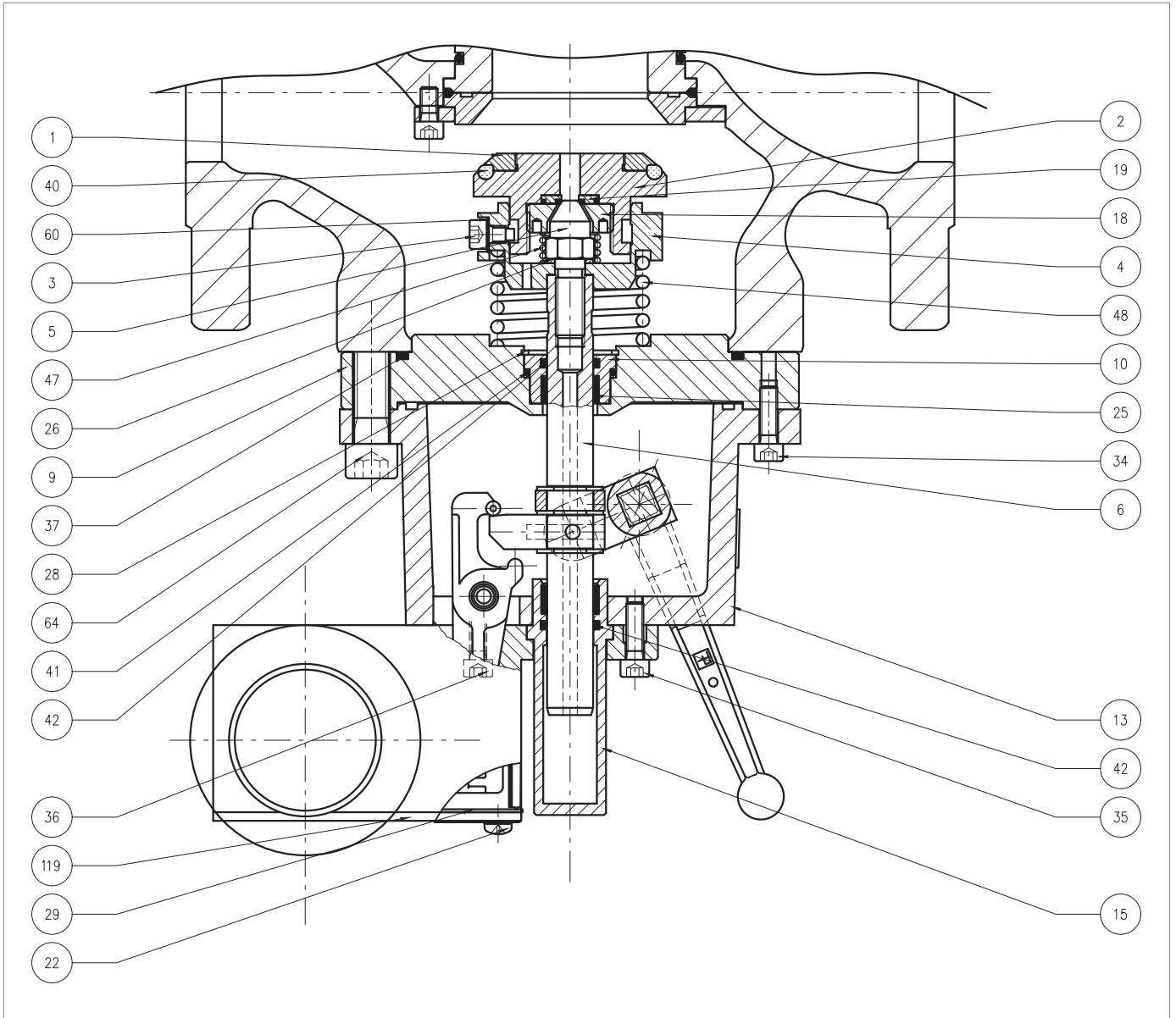







Fig. 9.72. Incorporated slam-shut valve SB/82 2"÷ 3"

Step	Action
1	 <b>WARNING!</b> <b>Check that the slam-shut valve is in the shut-off position.</b>
2	Unscrew the minimum spring (Fig. 8.34, ref. 17).  <b>NOTICE!</b> <b>Check that the minimum spring is present.</b>
3	Arm the slam-shut valve by moving the reset lever (16) to the opening position.
4	Undo and remove the screws (64).  <b>WARNING!</b> <b>Partially unscrew all screws before removing the first one to allow the spring to stretch.</b>  <b>NOTICE!</b> <b>In this step, support the built-in SB/82 slam-shut valve.</b>
5	Remove the slam-shut valve and place it on an impact-resistant surface with the plug (2) facing downwards.  <b>NOTICE!</b> <b>Take care not to press the reset button (see fig. 4.10, ref. 10).</b>
6	Disarm the slam-shut valve by pressing the reset button (fig. 4.10, ref. 10).  <b>NOTICE!</b> <ul style="list-style-type: none"> <li>• <b>During this phase, slowly move the reset lever (16) to the 'CLOSED' position</b></li> <li>• <b>Take care not to damage the plug (2)</b></li> </ul>
7	Remove the O-ring (37) from the flange (9) and replace it, taking care to lubricate it with synthetic grease.  <b>NOTICE!</b> <b>Before inserting the replacement O-ring, clean the retaining slots with a cleaning solution.</b>
8	Undo the screws (3) together with the toothed washers (60).
9	Take out the plug unit.
10	Remove the spring (47).
11	Unscrew and remove the ring nut (18) with the appropriate tool.  <b>NOTICE!</b> <b>Please refer to “Tab. 7.57” at “7.1 - List of equipment”.</b>
12	Remove and replace the pad (19).
13	Fit and fix the ring nut (18) with the appropriate tool.  <b>NOTICE!</b> <b>Please refer to “Tab. 7.57” at “7.1 - List of equipment”.</b>
14	Unscrew and remove the ring nut (1).



*Incorporated slam-shut valve SB/82 2" ÷ 3"*

Step	Action
15	Remove the O-ring (40) from the plug (2) and replace it, taking care to lubricate it with synthetic grease. <div style="border: 1px solid black; padding: 5px;">  <b>NOTICE!</b>  <b>Before inserting the replacement O-ring, clean the retaining slots with a cleaning solution.</b> </div>
16	Refit and secure the ring nut (1).
17	Undo the plug screw (5).
18	Remove the washer (26).
19	Remove the spring (48) and the spring support (4).
20	Undo and remove the screws (22) of the pressure switch.
21	Remove the cover (119) together with the gasket (29).
22	Undo the side screws (36) inside the control pressure switch.
23	Undo the external screws (35).
24	Take out the pressure switch unit. <div style="border: 1px solid black; padding: 5px;">  <b>NOTICE!</b>  <b>For the maintenance procedure of the pressure switch unit, refer to the relative table.</b> </div>
25	Remove the cup (15).
26	Remove the O-ring (42) from the cup (15) and replace it, taking care to lubricate it with synthetic grease. <div style="border: 1px solid black; padding: 5px;">  <b>NOTICE!</b>  <b>Before inserting the replacement O-ring, clean the retaining slots with a cleaning solution.</b> </div>
27	Undo and remove the screws (34).
28	Remove the intermediate body (13)
29	Extract the stem (6) taking care not to damage it.
30	Remove the Seeger ring (28) from the flange (9).
31	Remove the bush (10).
32	Remove the O-ring (41) from the flange (9) and replace it, taking care to lubricate it with synthetic grease. <div style="border: 1px solid black; padding: 5px;">  <b>NOTICE!</b>  <b>Before inserting the replacement O-ring, clean the retaining slots with a cleaning solution.</b> </div>
33	Remove the O-ring (42) from the bush (10) and replace it, lubricating it with synthetic grease. <div style="border: 1px solid black; padding: 5px;">  <b>NOTICE!</b>  <b>Before inserting the replacement O-ring, clean the retaining slots with a cleaning solution.</b> </div>
34	Remove the I/DWR ring (25) from the bush (10) and replace it, taking care to lubricate it with synthetic grease. <div style="border: 1px solid black; padding: 5px;">  <b>NOTICE!</b>  <b>Before fitting the replacement I/DWR ring, clean the retaining slots using a cleaning solution.</b> </div>

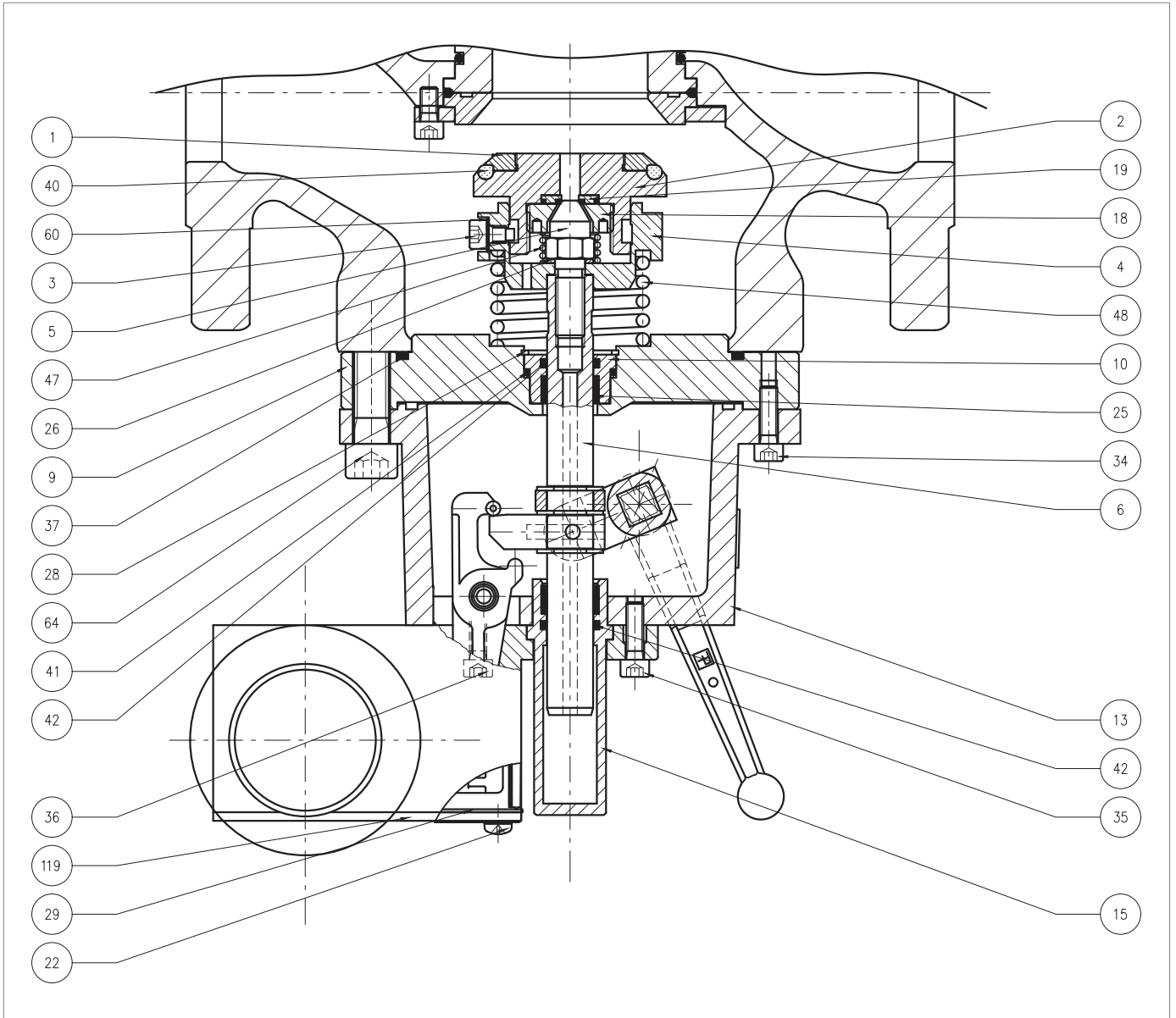

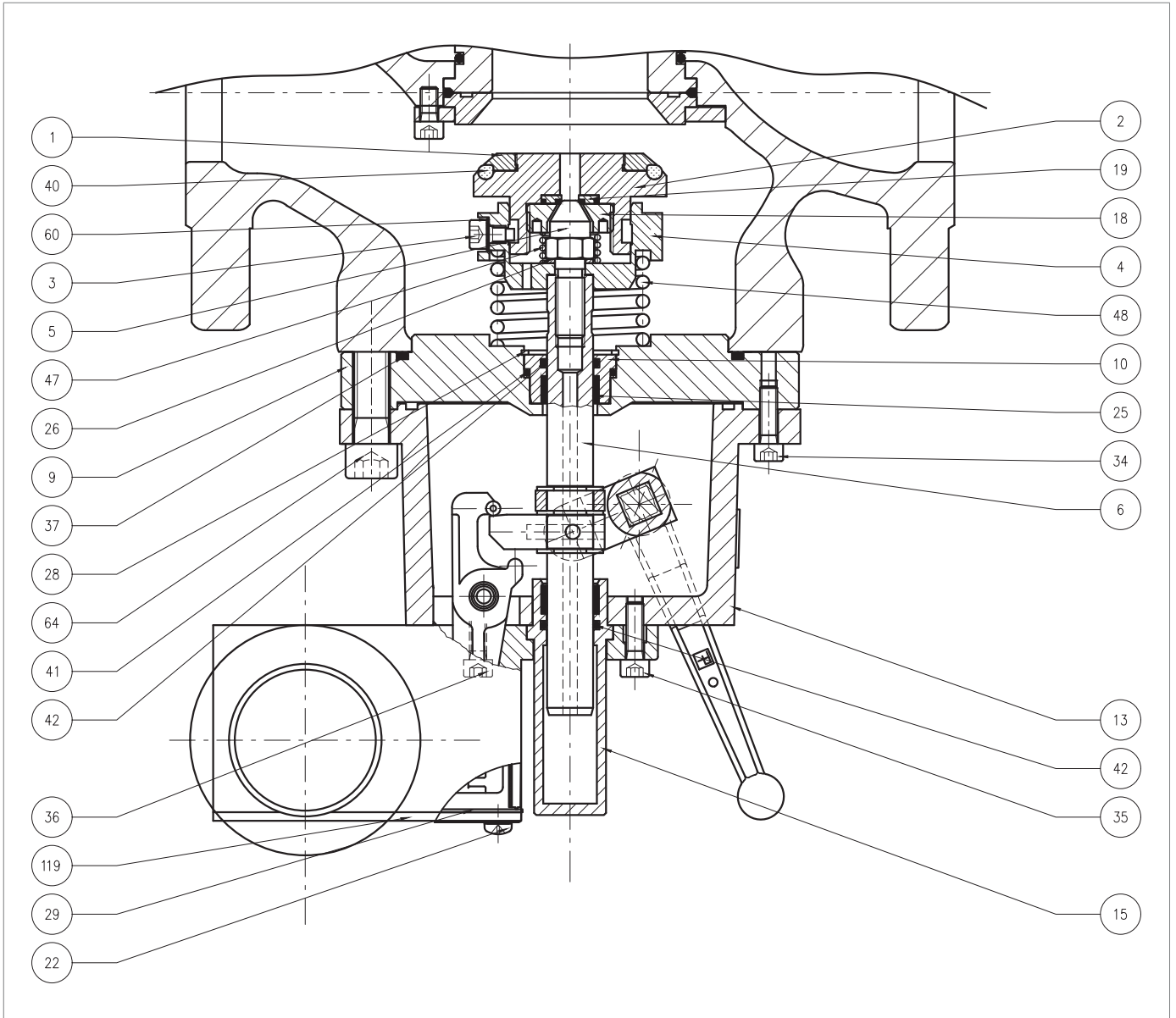

*Incorporated slam-shut valve SB/82 2" ÷ 3"*

Step	Action
35	Fit the valve seat (10), taking care not to damage the O-ring (41).
36	Place the Seeger ring (28) in the flange (9).
37	Place the stem (6) in the bush (10). <b>NOTICE!</b> <b>Lubricate the stem surface with silicone grease.</b>
38	Fit the intermediate body (13).
39	Insert and fix the screws (34).
40	Fit the cup (15).
41	Fit the pressure switch unit.
42	Insert and fix the screws (35) according to the following tightening torque: <ul style="list-style-type: none"> <li>• 2": Tab. 9.109</li> <li>• 3": Tab. 9.110</li> </ul> <b>NOTICE!</b> <b>Tighten the screws as shown in the diagram at "9.4.2.2 - Cross diagram for tightening screws".</b>
43	Insert and fix the side screws (36) according to the following tightening torque: <ul style="list-style-type: none"> <li>• 2": Tab. 9.109</li> <li>• 3": Tab. 9.110</li> </ul> <b>NOTICE!</b> <b>Tighten the screws as shown in the diagram at "9.4.2.2 - Cross diagram for tightening screws".</b>
44	Fit the gasket (29) together with the cover (119).
45	Insert and fix the screws (22).
46	Put the spring (48) and spring support (4) in place.
47	Fit the washer (26).
48	Insert and fix the plug screws (5) according to the following tightening torque: <ul style="list-style-type: none"> <li>• 2": Tab. 9.109</li> <li>• 3": Tab. 9.110</li> </ul> <b>NOTICE!</b> <ul style="list-style-type: none"> <li>• <b>Before inserting the screw (5), apply thread locking glue;</b></li> <li>• <b>Tighten the screws as shown in the diagram at "9.4.2.2 - Cross diagram for tightening screws".</b></li> </ul>
49	Fit the spring (47).
50	Fit the plug unit.
51	Insert the screws (3) together with the toothed washers (60). <b>NOTICE!</b> <b>Before inserting the screw (3), apply thread locking glue.</b>
52	Fasten the screws (3), holding down the plug unit to compress the spring (47) in the plug guide (4).
53	Turn the slam-shut valve upside down with the plug (2) facing downwards on an impact-resistant surface.
54	Arm the slam-shut valve by moving the reset lever (16) to the opening position



*Incorporated slam-shut valve SB/82 2" ÷ 3"*

Step	Action
55	<p>Position the slam-shut valve.</p> <div style="border: 1px solid blue; padding: 5px;"> <p> <b>NOTICE!</b></p> <p><b>Take care not to press the reset button (see fig. 4.10, ref. 10).</b></p> </div>
56	<p>Insert and fix the screws (64) according to the following tightening torque:</p> <ul style="list-style-type: none"> <li>• 2": Tab. 9.109</li> <li>• 3": Tab. 9.110</li> </ul> <div style="border: 1px solid blue; padding: 5px;"> <p> <b>NOTICE!</b></p> <p><b>Tighten the screws as shown in the diagram at "9.4.2.2 - Cross diagram for tightening screws".</b></p> </div>

Tab. 9.146

 **WARNING!**

**Ensure that all parts have been fitted correctly.**

**9.4.8.3 - INCORPORATED SLAM-SHUT VALVE SB/82 4" - 8"**

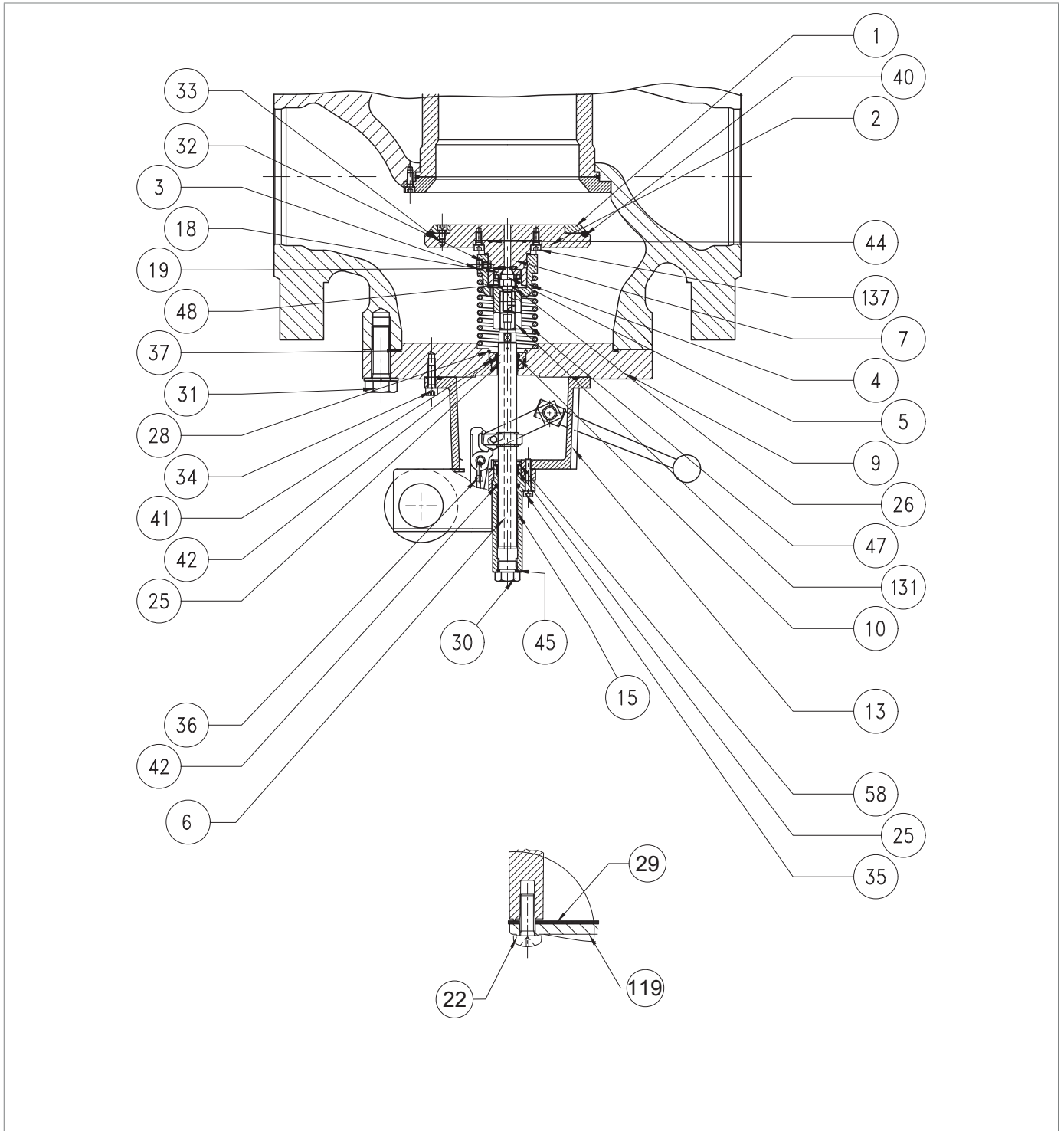







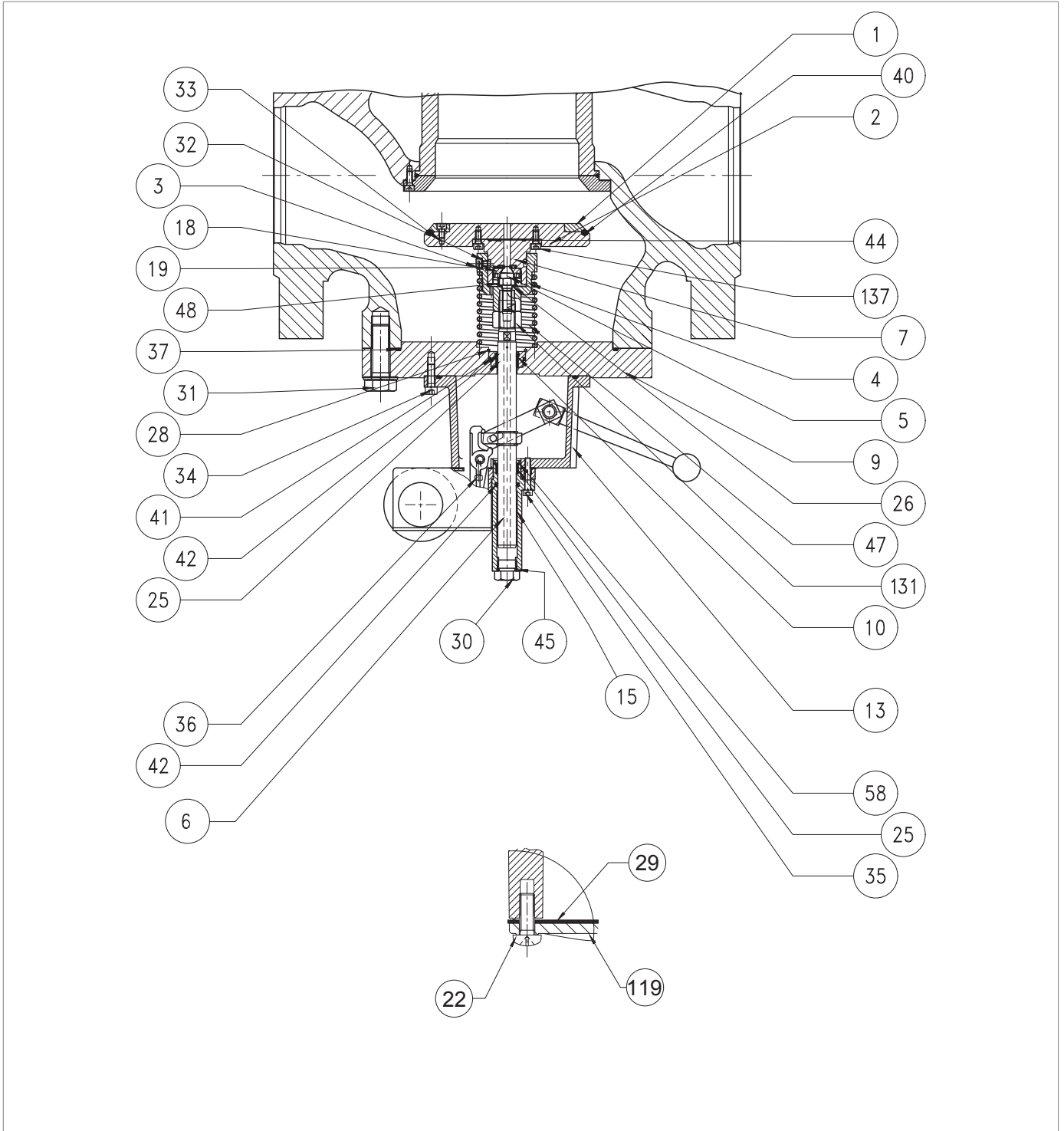

Fig. 9.73. Built-in slam-shut valve SB/82 4" ÷ 8"

Step	Action
1	 <b>WARNING!</b> <b>Check that the slam-shut valve is in the shut-off position.</b>
2	Unscrew the minimum spring (Fig. 8.34, ref. 17).  <b>NOTICE!</b> <b>Check that the minimum spring is present.</b>
3	Arm the slam-shut valve by moving the reset lever (16) to the 'OPEN' position.
4	Undo and remove the screws (31).  <b>WARNING!</b> <b>Partially unscrew all screws before removing the first one to allow the spring to stretch.</b>  <b>NOTICE!</b> <b>In this step, support the built-in SB/82 slam-shut valve.</b>
5	Remove the O-ring (37) from the flange (9) and replace it, taking care to lubricate it with synthetic grease.  <b>NOTICE!</b> <b>Before inserting the replacement O-ring, clean the retaining slots with a cleaning solution.</b>
6	Undo the screws (3) together with the toothed washers (32).
7	Take out the plug unit.
8	Remove the spring (47).
9	Unscrew and remove the ring nut (18) with an appropriate tool.  <b>NOTICE!</b> <b>Please refer to “Tab. 7.57” at “7.1 - List of equipment”.</b>
10	Remove and replace the pad (19).
11	Fit and fix the ring nut (18) with the appropriate tool.
12	Undo and remove the screws (137).
13	Remove the O-ring (44) from the plug support (7) and replace it, taking care to lubricate it with synthetic grease.  <b>NOTICE!</b> <b>Before inserting the replacement O-ring, clean the retaining slots with a cleaning solution.</b>
14	Undo the screws (33).
15	Remove the ring nut (1).
16	Remove the O-ring (40) from the plug (2) and replace it, taking care to lubricate it with synthetic grease.  <b>NOTICE!</b> <b>Before inserting the replacement O-ring, clean the retaining slots with a cleaning solution.</b>
17	Fit the ring nut (1).



*Built-in slam-shut valve SB/82 4"÷ 8"*

Step	Action
18	<p>Insert and fix the screws (33) according to the following tightening torques:</p> <ul style="list-style-type: none"> <li>• 4": Tab. 9.111</li> <li>• 6": Tab. 9.112</li> <li>• 8": Tab. 9.113</li> </ul> <div style="border: 1px solid black; padding: 5px;"> <p><b>! NOTICE!</b></p> <p><b>Tighten the screws as shown in the diagram at "9.4.2.2 - Cross diagram for tightening screws".</b></p> </div>
19	Place the plug (2) on the plug support (7).
20	<p>Insert and fix the screws (137) according to the following tightening torques:</p> <ul style="list-style-type: none"> <li>• 4": Tab. 9.111</li> <li>• 6": Tab. 9.112</li> <li>• 8": Tab. 9.113</li> </ul> <div style="border: 1px solid black; padding: 5px;"> <p><b>! NOTICE!</b></p> <p><b>Tighten the screws as shown in the diagram at "9.4.2.2 - Cross diagram for tightening screws".</b></p> </div>
21	Undo the plug screw (5).
22	Remove the washer (26).
23	Remove the spring (48) and the spring support (4).
24	Unscrew and remove the nut (131).
25	Undo and remove the screws (22) of the pressure switch.
26	Remove the cover (119) and the gasket (29).
27	Undo the side screws (36) inside the control pressure switch.
28	Undo the screws (35).
29	Remove the cup (15).
30	<p>Remove the O-ring (42) from the cup (15) and replace it, taking care to lubricate it with synthetic grease.</p> <div style="border: 1px solid black; padding: 5px;"> <p><b>! NOTICE!</b></p> <p><b>Before inserting the replacement O-ring, clean the retaining slots with a cleaning solution.</b></p> </div>
31	Remove the cap (30).
32	<p><b>VALID ONLY FOR 6"-8"</b></p> <p>Remove the O-ring (45) from the cap (30) and replace it, taking care to lubricate it with synthetic grease.</p> <div style="border: 1px solid black; padding: 5px;"> <p><b>! NOTICE!</b></p> <p><b>Before inserting the replacement O-ring, clean the retaining slots with a cleaning solution.</b></p> </div>
33	Remove the Seeger ring (58) from the cup (15).
34	<p>Remove the I/DWR ring (25) from the cup (15) and replace it, taking care to lubricate it with synthetic grease.</p> <div style="border: 1px solid black; padding: 5px;"> <p><b>! NOTICE!</b></p> <p><b>Before fitting the replacement I/DWR ring, clean the retaining slots using a cleaning solution.</b></p> </div>
35	Place the Seeger ring (58) in the cup (15).
36	<p>Take out the pressure switch unit.</p> <div style="border: 1px solid black; padding: 5px;"> <p><b>! NOTICE!</b></p> <p><b>For the maintenance procedure of the pressure switch unit, refer to the relative table.</b></p> </div>

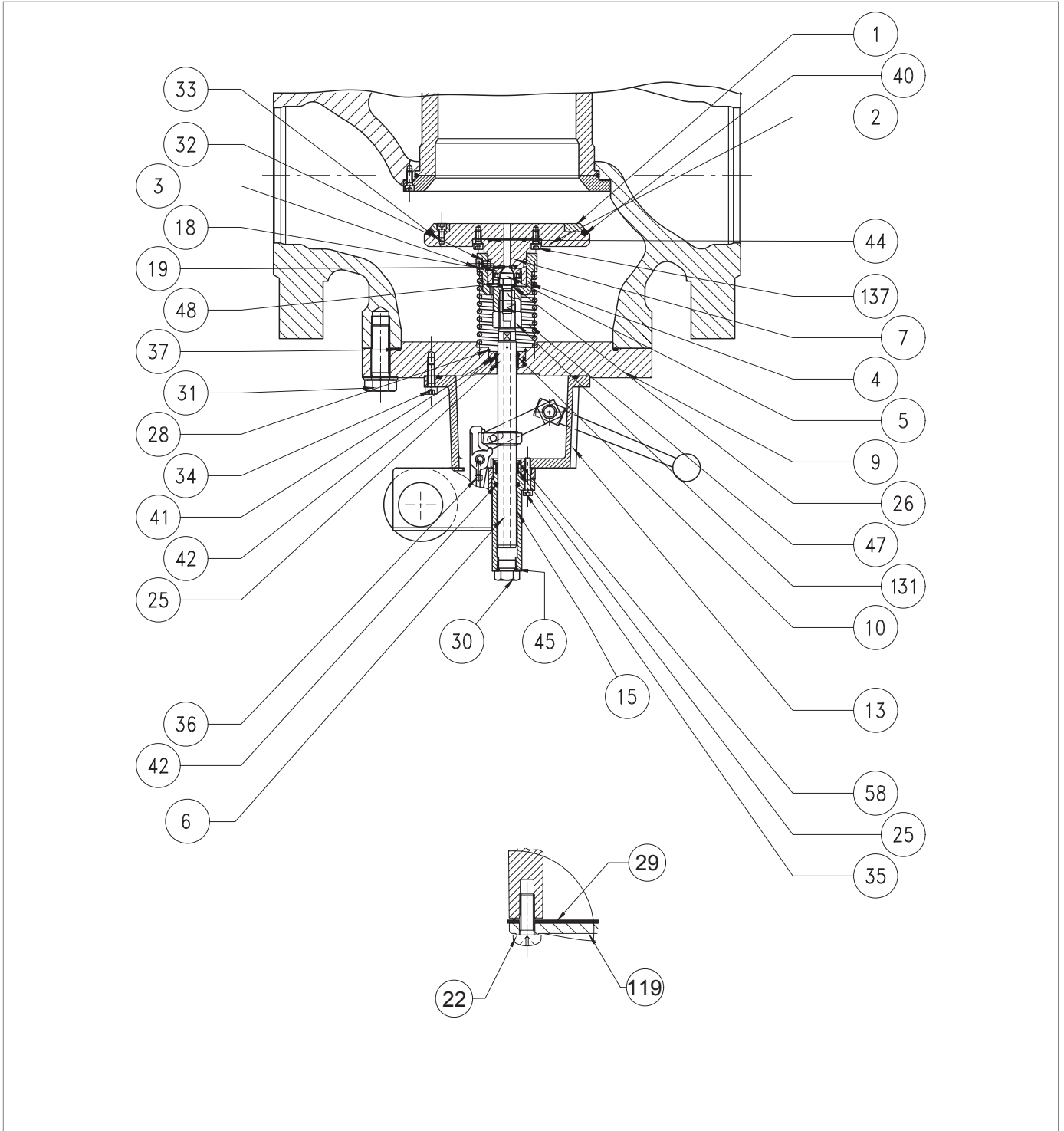



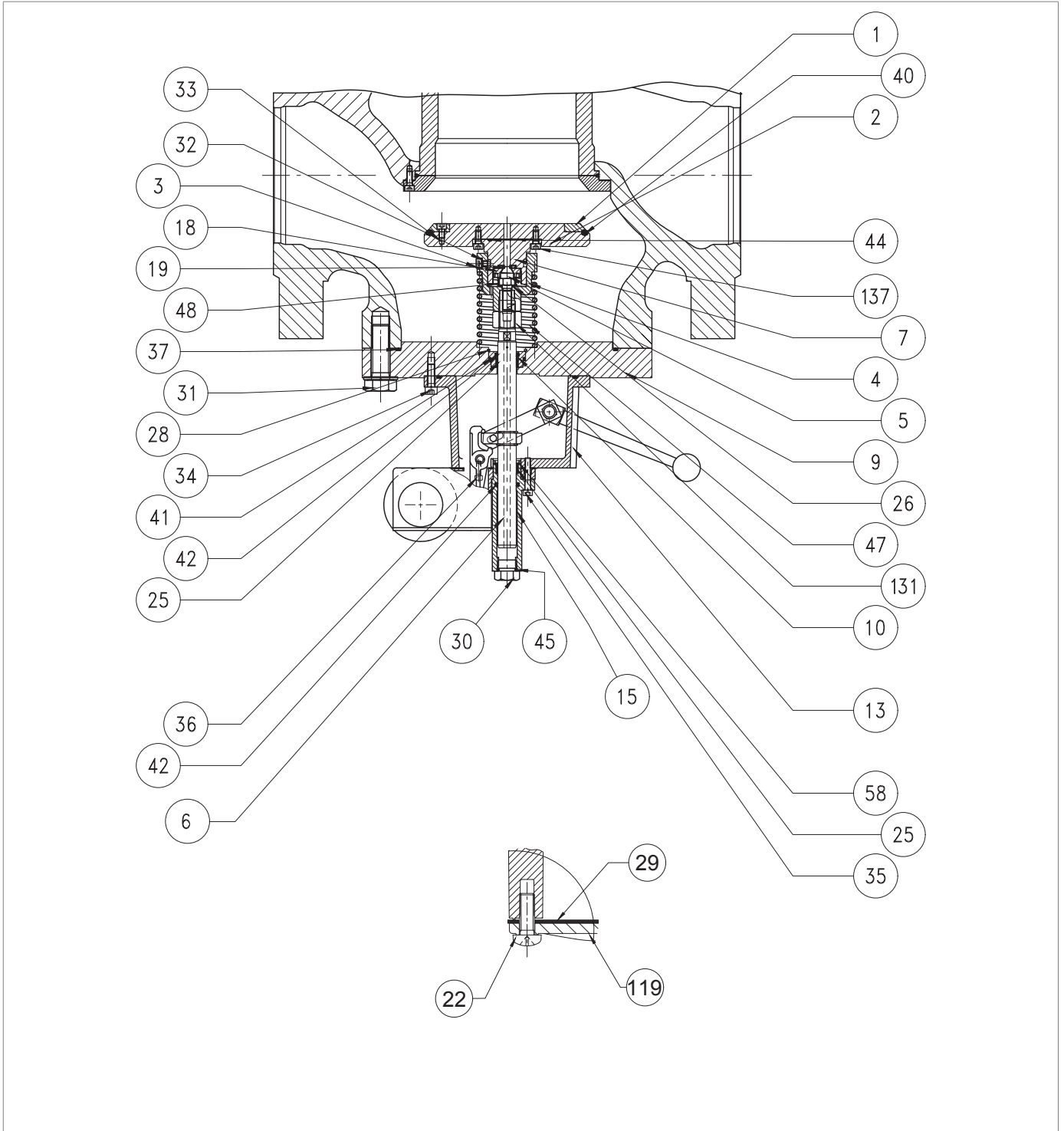

*Built-in slam-shut valve SB/82 4"÷ 8"*

Step	Action
37	Undo and remove the screws (34).
38	Remove the intermediate body (13).
39	Remove the Seeger ring (28) from the flange (9).
40	Remove the bush (10).
41	Remove the O-ring (41) from the flange (9) and replace it, taking care to lubricate it with synthetic grease. <div style="border: 1px solid black; padding: 5px;"><b>! NOTICE!</b>  <b>Before inserting the replacement O-ring, clean the retaining slots with a cleaning solution.</b></div>
42	Remove the O-ring (42) from the bush (10) and replace it, lubricating it with synthetic grease. <div style="border: 1px solid black; padding: 5px;"><b>! NOTICE!</b>  <b>Before inserting the replacement O-ring, clean the retaining slots with a cleaning solution.</b></div>
43	Remove the I/DWR ring (25) from the bush (10) and replace it, taking care to lubricate it with synthetic grease. <div style="border: 1px solid black; padding: 5px;"><b>! NOTICE!</b>  <b>Before fitting the replacement I/DWR ring, clean the retaining slots using a cleaning solution.</b></div>
44	Fit the valve seat (10), taking care not to damage the O-ring (41).
45	Place the Seeger ring (28) in the flange (9).
46	Place the stem (6) in the bush (10). <div style="border: 1px solid black; padding: 5px;"><b>! NOTICE!</b>  <b>Lubricate the stem surface with silicone grease.</b></div>
47	Fit the intermediate body (13).
48	Insert and fix the screws (34) according to the following tightening torques: <ul style="list-style-type: none"> <li>• 4": Tab. 9.111</li> <li>• 6": Tab. 9.112</li> <li>• 8": Tab. 9.113</li> </ul> <div style="border: 1px solid black; padding: 5px;"><b>! NOTICE!</b>  <b>Tighten the screws as shown in the diagram at "9.4.2.2 - Cross diagram for tightening screws".</b></div>
49	Fit the pressure switch unit.
50	Fit the cup (15).
51	Insert and fix the screws (35) according to the following tightening torques: <ul style="list-style-type: none"> <li>• 4": Tab. 9.111</li> <li>• 6": Tab. 9.112</li> <li>• 8": Tab. 9.113</li> </ul> <div style="border: 1px solid black; padding: 5px;"><b>! NOTICE!</b>  <b>Tighten the screws as shown in the diagram at "9.4.2.2 - Cross diagram for tightening screws".</b></div>
52	Insert and fix the side screws (36) into the pressure switch according to the following tightening torques: <ul style="list-style-type: none"> <li>• 4": Tab. 9.111</li> <li>• 6": Tab. 9.112</li> <li>• 8": Tab. 9.113</li> </ul> <div style="border: 1px solid black; padding: 5px;"><b>! NOTICE!</b>  <b>Tighten the screws as shown in the diagram at "9.4.2.2 - Cross diagram for tightening screws".</b></div>



*Built-in slam-shut valve SB/82 4"÷ 8"*

Step	Action
53	Fit and fix the cap (30).
54	Fit the gasket (29) and the cover (119).
55	Insert and fix the screws (22). <div style="border: 1px solid black; padding: 5px;">  <b>NOTICE!</b>  <b>Tighten the screws as shown in the diagram at “9.4.2.2 - Cross diagram for tightening screws”.</b> </div>
56	Insert and fix the screws (131).
57	Put the spring (48) and spring support (4) in place.
58	Fit the washer (26).
59	Apply thread locking glue to insert and fix the plug screws (5) according to the following tightening torque: <ul style="list-style-type: none"> <li>• 4”: Tab. 9.111</li> <li>• 6”: Tab. 9.112</li> <li>• 8”: Tab. 9.113</li> </ul> <div style="border: 1px solid black; padding: 5px;">  <b>NOTICE!</b>  <b>Tighten the screws as shown in the diagram at “9.4.2.2 - Cross diagram for tightening screws”.</b> </div>
60	Fit the spring (47).
61	Fit the plug unit.
62	Insert the screws (3) together with the toothed washers (60). <div style="border: 1px solid black; padding: 5px;">  <b>NOTICE!</b>  <b>Before inserting the screw (3), apply thread locking glue.</b> </div>
63	Fasten the screws (3), holding down the plug unit to compress the spring (47) in the plug guide (4).
64	Turn the slam-shut valve upside down with the plug (2) facing downwards on an impact-resistant surface.
65	Arm the slam-shut valve by moving the reset lever (16) to the opening position
66	Position the slam-shut valve. <div style="border: 1px solid black; padding: 5px;">  <b>NOTICE!</b>  <b>Take care not to press the reset button (see fig. 4.10, ref. 10).</b> </div>
67	Insert and fix the screws (31) according to the following tightening torque: <ul style="list-style-type: none"> <li>• 4”: Tab. 9.111</li> <li>• 6”: Tab. 9.112</li> <li>• 8”: Tab. 9.113</li> </ul> <div style="border: 1px solid black; padding: 5px;">  <b>NOTICE!</b>  <b>Tighten the screws as shown in the diagram at “9.4.2.2 - Cross diagram for tightening screws”.</b> </div>

Tab. 9.147

 **WARNING!**  
**Ensure that all parts have been fitted correctly.**

**9.4.8.4 - BUILT-IN SLAM-SHUT VALVE SB/82 10"**

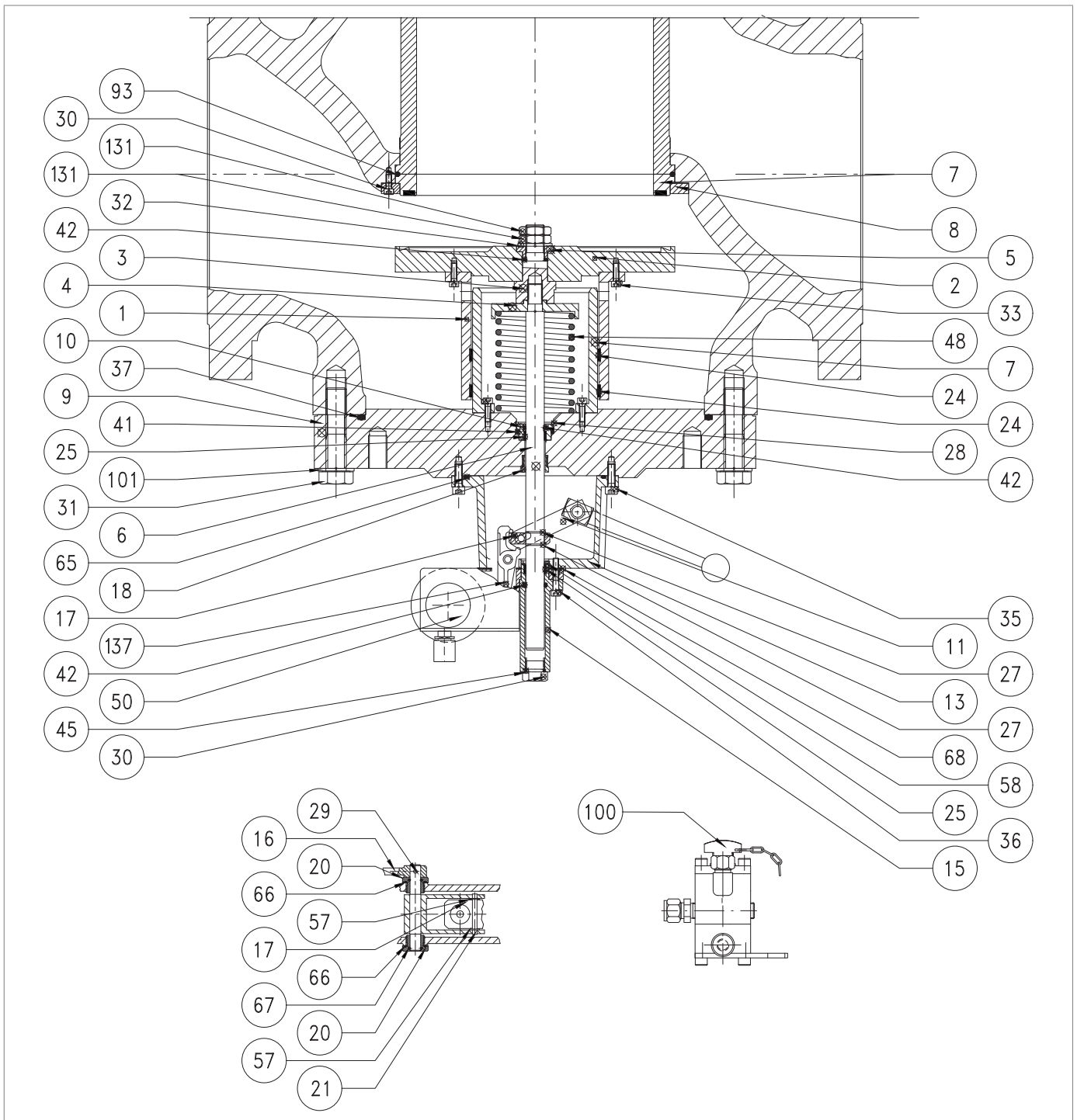



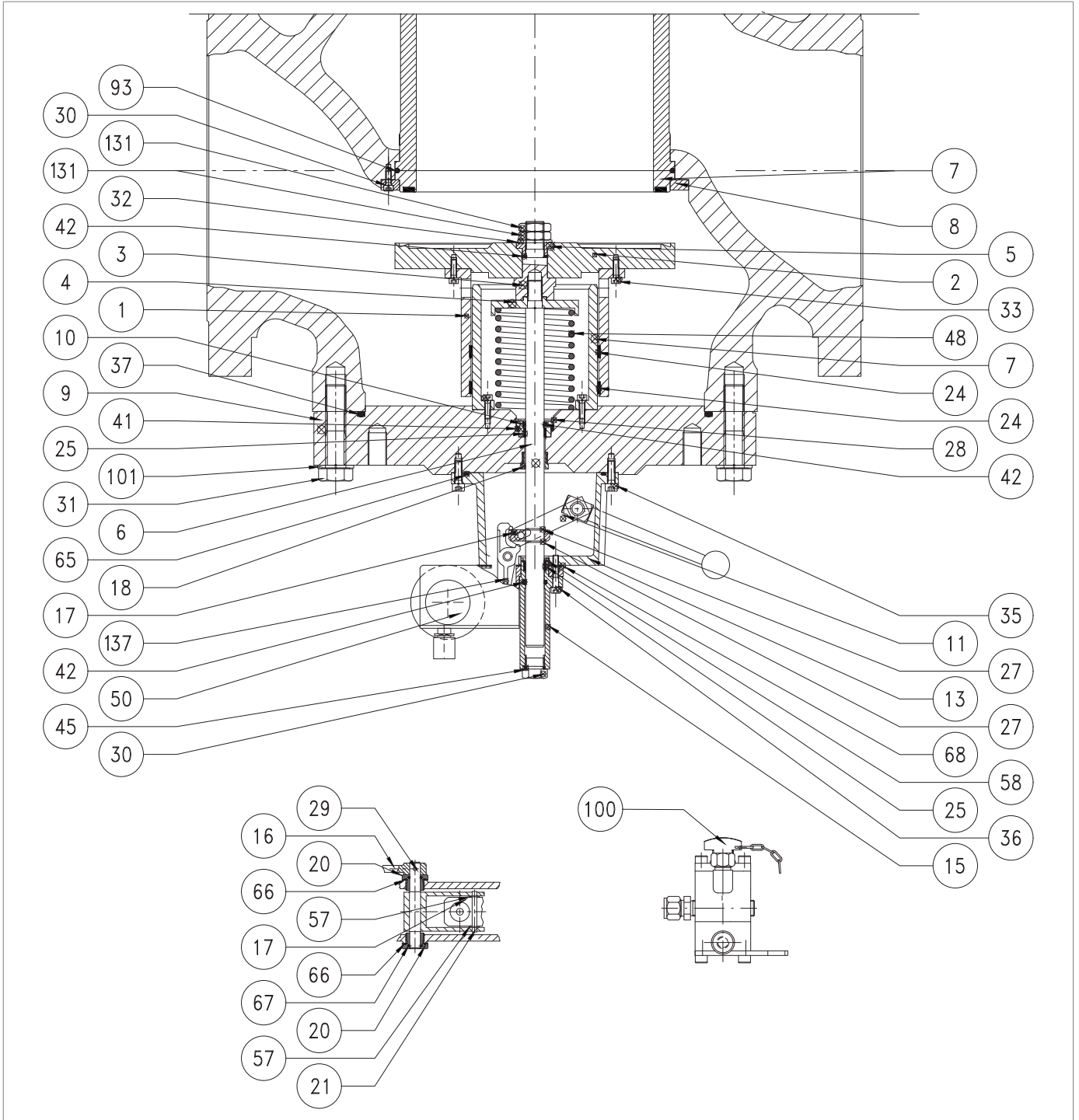







Fig. 9.74. Built-in slam-shut valve SB/82 10"

Step	Action
1	 <b>WARNING!</b> <b>Check that the slam-shut valve is in the shut-off position.</b>
2	Unscrew the minimum spring (Fig. 8.34, ref. 17).  <b>NOTICE!</b> <b>Check that the minimum spring is present.</b>
3	Arm the slam-shut valve by moving the reset lever (16) to the 'OPEN' position.
4	Undo and remove the screws (36).  <b>WARNING!</b> <b>Partially unscrew all screws before removing the first one to allow the spring to stretch.</b>  <b>NOTICE!</b> <b>In this step, support the built-in SB/82 slam-shut valve.</b>
5	Remove the slam-shut valve and place it on an impact-resistant surface with the plug (2) facing downwards.  <b>NOTICE!</b> <b>Take care not to press the reset button (see fig. 4.10, ref. 10).</b>
6	Disarm the slam-shut valve by pressing the reset button (fig. 4.10, ref. 10).  <b>NOTICE!</b> <ul style="list-style-type: none"> <li>• <b>During this phase, slowly move the reset lever (16) to the 'CLOSED' position</b></li> <li>• <b>Take care not to damage the plug (2)</b></li> </ul>
7	Undo and remove the screws (31).
8	Remove the SB/82 built-in slam-shut valve and place it on a shock-proof surface.
9	Remove the O-ring (37) from the flange (9) and replace it, taking care to lubricate it with synthetic grease.  <b>NOTICE!</b> <b>Before inserting the replacement O-ring, clean the retaining slots with a cleaning solution.</b>
10	Unscrew and remove the nuts (131) together with the washer (32).
11	Remove the plug (2) together with the plug sleeve (1) and the bush (5).
12	Remove the bush (5).
13	Remove the O-ring (42) from the bush (5) and replace it, lubricating it with synthetic grease.  <b>NOTICE!</b> <b>Before inserting the replacement O-ring, clean the retaining slots with a cleaning solution.</b>
14	Undo and remove the screws (33).
15	Separate the plug (2) from the plug sleeve (1).



*Built-in slam-shut valve SB/82 10''*

Step	Action
16	Remove the I/DWR rings (24) from the plug sleeve (1) and replace them, lubricating them with synthetic grease. <div style="border: 1px solid black; padding: 5px;">  <b>NOTICE!</b>  <b>Before fitting the replacement I/DWR ring, clean the retaining slots using a cleaning solution.</b> </div>
17	Unscrew and remove the extension (3) from the stem (6).
18	Remove the spring (48) and the spring support (4).
19	Undo and remove the screws (22) of the pressure switch.
20	Remove the cover (19) and the gasket (29).
21	Undo the side screws (137) inside the control pressure switch.
22	Undo the screws (36).
23	Remove the cup (15).
24	Remove the O-ring (42) from the cup (15) and replace it, taking care to lubricate it with synthetic grease. <div style="border: 1px solid black; padding: 5px;">  <b>NOTICE!</b>  <b>Before inserting the replacement O-ring, clean the retaining slots with a cleaning solution.</b> </div>
25	Remove the cap (30).
26	Remove the O-ring (45) from the cap (30) and replace it, taking care to lubricate it with synthetic grease. <div style="border: 1px solid black; padding: 5px;">  <b>NOTICE!</b>  <b>Before inserting the replacement O-ring, clean the retaining slots with a cleaning solution.</b> </div>
27	Remove the Seeger ring (58) from the cup (15).
28	Remove the I/DWR ring (25) from the cup (15) and replace it, taking care to lubricate it with synthetic grease. <div style="border: 1px solid black; padding: 5px;">  <b>NOTICE!</b>  <b>Before fitting the replacement I/DWR ring, clean the retaining slots using a cleaning solution.</b> </div>
29	Place the Seeger ring (58) in the cup (15).
30	Take out the pressure switch unit. <div style="border: 1px solid black; padding: 5px;">  <b>NOTICE!</b>  <b>For the maintenance procedure of the pressure switch unit, refer to the relative table.</b> </div>
31	Undo and remove the screws (35).
32	Remove the intermediate body (13).
33	Remove the stem (6) taking care not to damage it.
34	Remove the Seeger ring (28) from the flange (9).
35	Remove the bush (10).
36	Remove the O-ring (41) from the flange (9) and replace it, taking care to lubricate it with synthetic grease. <div style="border: 1px solid black; padding: 5px;">  <b>NOTICE!</b>  <b>Before inserting the replacement O-ring, clean the retaining slots with a cleaning solution.</b> </div>

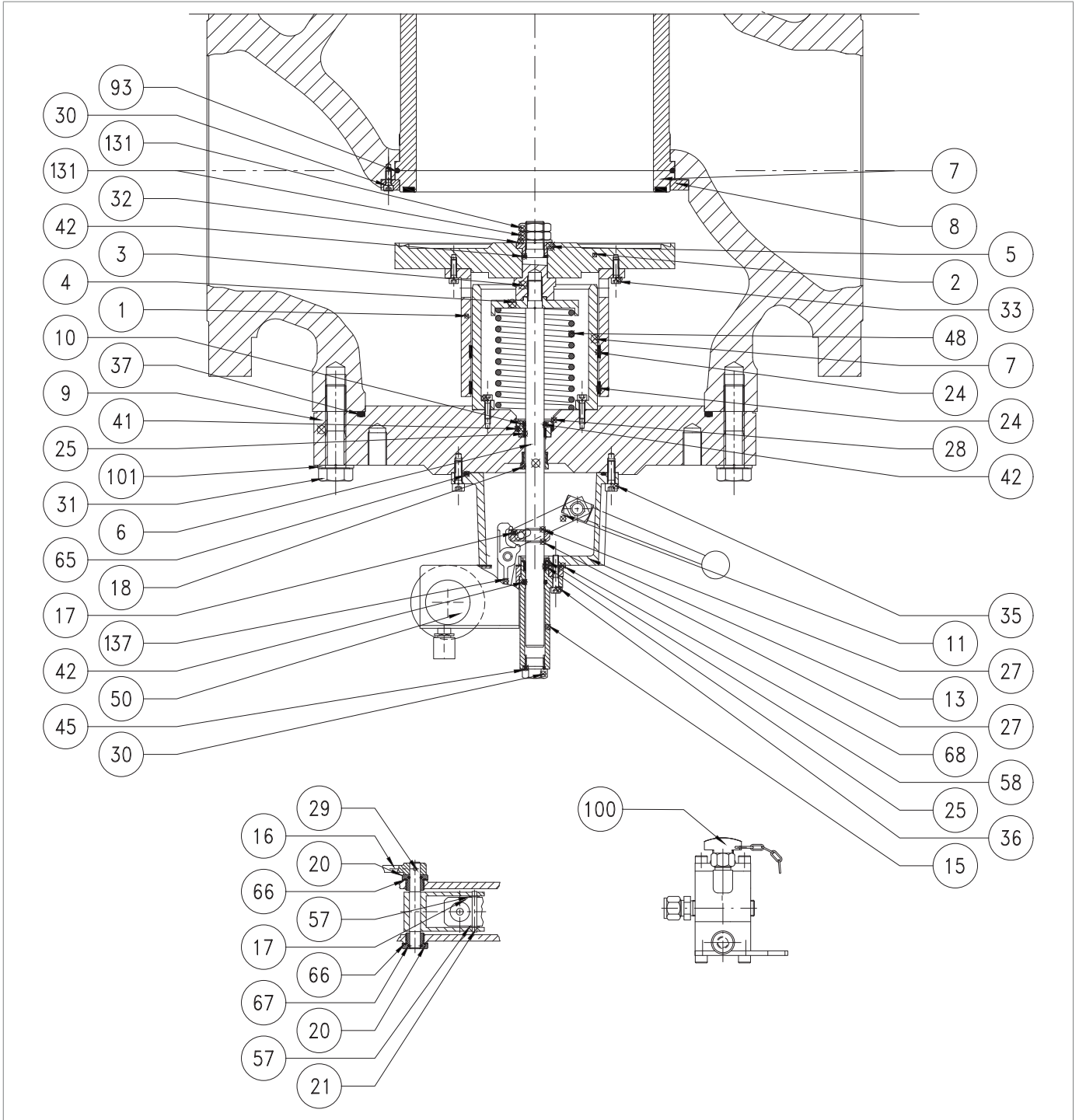

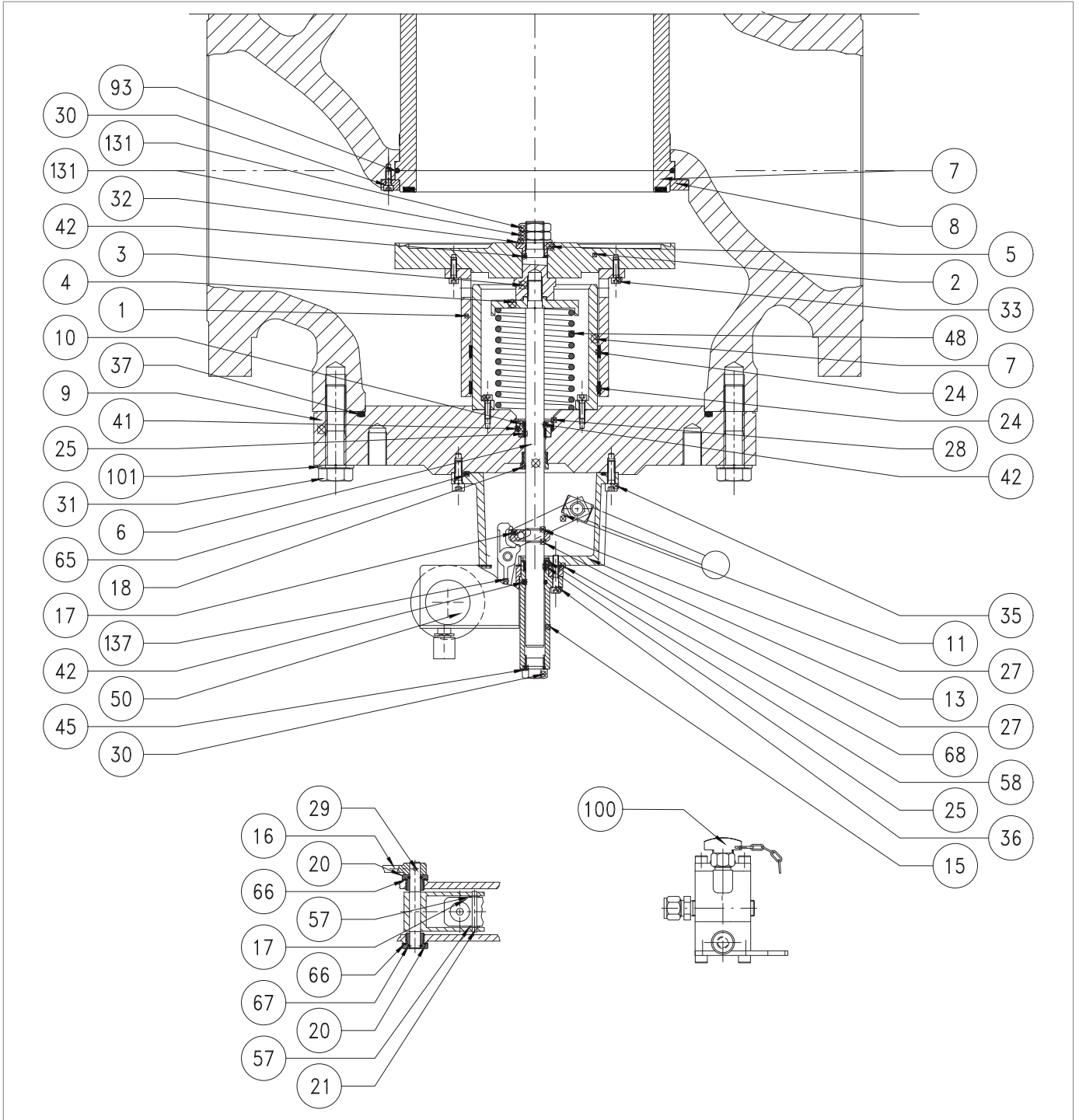

*Built-in slam-shut valve SB/82 10''*

Step	Action
37	Remove the O-ring (42) from the bush (10) and replace it, lubricating it with synthetic grease. <b>NOTICE!</b> <b>Before inserting the replacement O-ring, clean the retaining slots with a cleaning solution.</b>
38	Fit the valve seat (10), taking care not to damage the O-ring (41).
39	Place the Seeger ring (28) in the flange (9).
40	Place the stem (6) in the bush (10). <b>NOTICE!</b> <b>Lubricate the stem surface with silicone grease.</b>
41	Fit the intermediate body (13).
42	Fit the pressure switch unit.
43	Insert and fix the screws (35) according to the following tightening torque: • 10": Tab. 9.114 <b>NOTICE!</b> <b>Tighten the screws as shown in the diagram at "9.4.2.2 - Cross diagram for tightening screws".</b>
44	Fit the cup (15).
45	Insert and fix the side screws (137) into the pressure switch according to the following tightening torque: • 10": Tab. 9.114 <b>NOTICE!</b> <b>Tighten the screws as shown in the diagram at "9.4.2.2 - Cross diagram for tightening screws".</b>
46	Insert and fix the screws (36) according to the following tightening torque: • 10": Tab. 9.114 <b>NOTICE!</b> <b>Tighten the screws as shown in the diagram at "9.4.2.2 - Cross diagram for tightening screws".</b>
47	Fit and secure the cap (30).
48	Fit the gasket (29) and the cover (19).
49	Insert and fix the screws (22).
50	Place the plug sleeve (1) on the plug (2) and
51	Insert and fix the screws (33) according to the following tightening torque: • 10": Tab. 9.114 <b>NOTICE!</b> <b>Tighten the screws as shown in the diagram at "9.4.2.2 - Cross diagram for tightening screws".</b>
52	Fit the bush (5) in the plug (2).
53	Put the spring (48) and spring support (4) in place.
54	Position and screw the extension (3).
55	Fit the plug (2) together with the plug sleeve (1).
56	Position and secure the nuts (31), together with the washer (32).
57	Turn the slam-shut valve upside down with the plug (2) facing downwards on an impact-resistant surface.
58	Arm the slam-shut valve by moving the reset lever (16) to the opening position



*Built-in slam-shut valve SB/82 10''*

Step	Action
59	Position the slam-shut valve. <div style="border: 1px solid blue; padding: 2px;">  <b>NOTICE!</b>  <b>Take care not to press the reset button (see fig. 4.10, ref. 10).</b> </div>
60	Insert and fix the screws (31) according to the following tightening torque: <ul style="list-style-type: none"> <li>• 10": Tab. 9.114</li> </ul> <div style="border: 1px solid blue; padding: 2px;">  <b>NOTICE!</b>  <b>Tighten the screws as shown in the diagram at "9.4.2.2 - Cross diagram for tightening screws".</b> </div>

Tab. 9.148

 **WARNING!**  
**Ensure that all parts have been fitted correctly.**

**9.4.9 - MAINTENANCE PROCEDURE FOR PRESSURE SWITCHES MOD. 100**

**9.4.9.1 - PRESSURE SWITCH MOD. 102M/102MH**

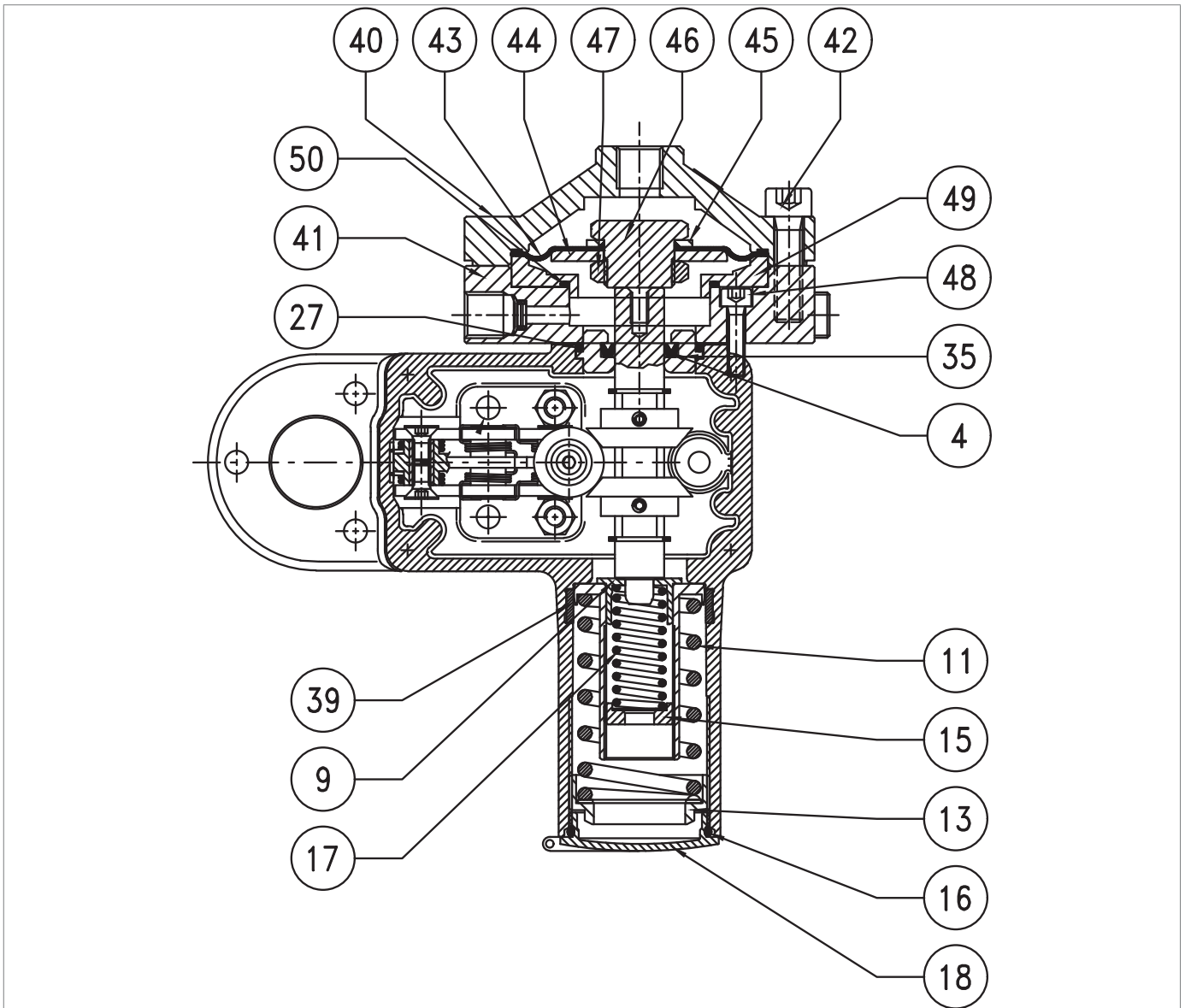
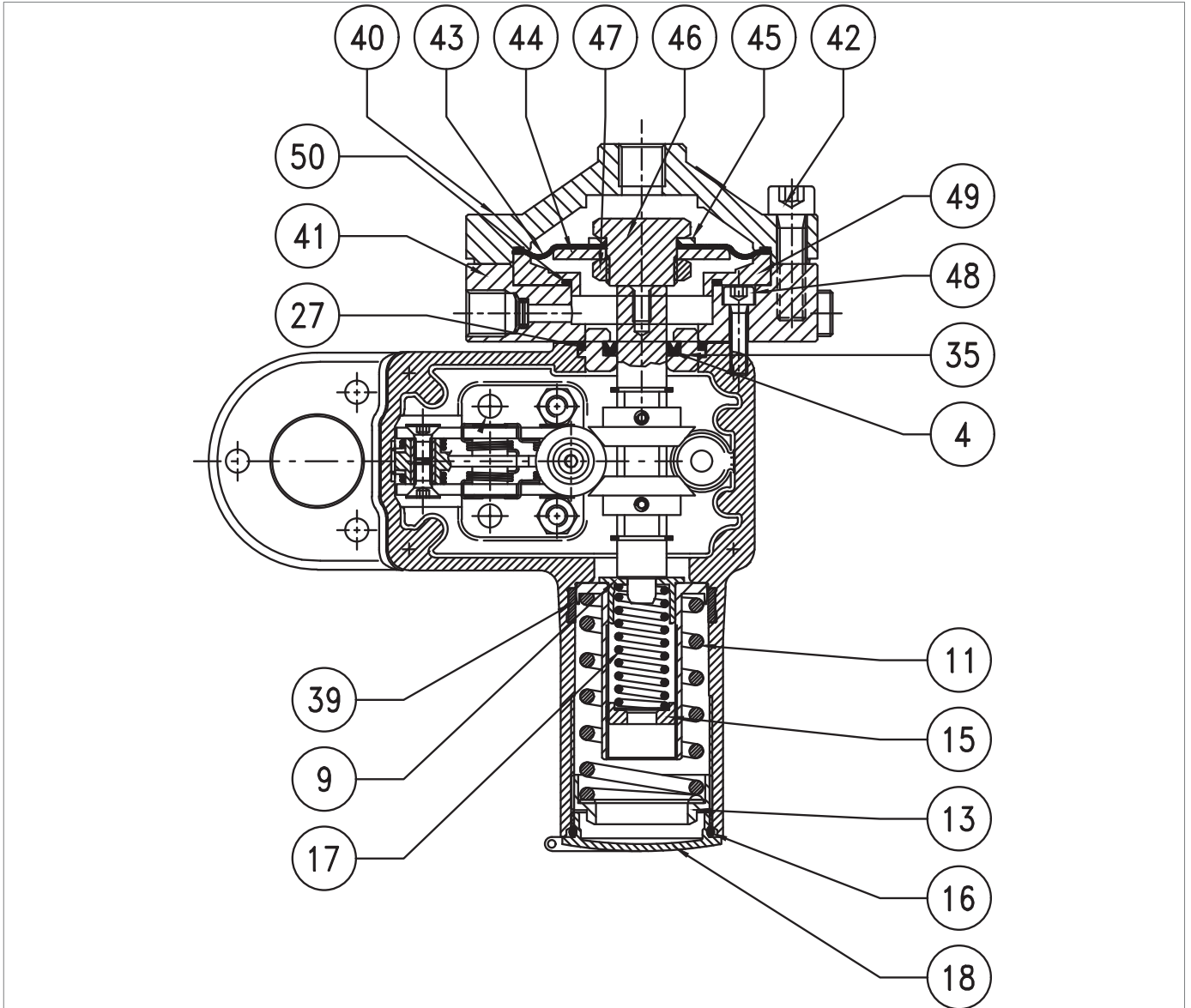

Fig. 9.75. Pressure switch Mod. 102M/102MH

Step	Action
1	Unscrew and remove the cap (18).
2	Remove the O-ring (16) from the cover (18) and replace it, lubricating it with synthetic grease. <b>NOTICE!</b> <b>Before inserting the replacement O-ring, clean the retaining slots with a cleaning solution.</b>
3	Completely release the spring (11) by adjusting the ring nut (13).
4	Completely release the minimum pressure spring (17) by adjusting the ring nut (15). <b>NOTICE!</b> <b>The minimum spring may not be installed.</b>
5	Remove the ring nut (13), the spring (11) and the spring support (17).
6	Remove the I/DWR ring (39) from the pressure switch sleeve and replace it, lubricating it with synthetic grease. <b>NOTICE!</b> <b>Before inserting the replacement I/DWR ring, clean the retaining slots with a cleaning solution.</b>
7	Undo and remove the screws (42).
8	Remove the upper cover (40).
9	Take out the diaphragm unit (43, 44, 45, 46, 47).
10	Unscrew the nut (47).
11	Remove the diaphragm protection disc (44).
12	Remove and replace the diaphragm (43), lubricating the lanyard with synthetic grease. <b>NOTICE!</b> <b>Before inserting the replacement diaphragm, clean the retaining slots with a cleaning solution.</b>
13	Fit the diaphragm protection disc (44).
14	Place and fix the nut (47) according to the following tightening torque: • Mod. 102: Tab. 9.115
15	Remove the ring (49).
16	Undo and remove the screws (48).
17	Remove the lower lid (41).
18	Remove the O-ring (50) from the nut (49) and replace it, lubricating it with synthetic grease. <b>NOTICE!</b> <b>Before inserting the replacement O-ring, clean the retaining slots with a cleaning solution.</b>
19	Remove the bush (35).
20	Remove the O-ring (27) from the bush (35) and replace it, lubricating it with synthetic grease. <b>NOTICE!</b> <b>Before inserting the replacement O-ring, clean the retaining slots with a cleaning solution.</b>



Pressure switch Mod. 102M/102MH

Step	Action
21	<p>Remove the U-shaped ring (4) from the bush (35) and replace it, lubricating it with synthetic grease.</p> <p><b>! NOTICE!</b>  <b>Before inserting the replacement U-ring, clean the retaining slots with a cleaning solution.</b></p>
22	<p>Position the bush (35) together with the O-ring (27).</p> <p><b>! NOTICE!</b>  <b>Before inserting the bush (35), lubricate the inner surface with silicone grease.</b></p>
23	<p>Fit the lower cover (41).</p> <p><b>! NOTICE!</b>  <b>Make sure there is a gasket between the lower cover and the pressure switch body.</b></p>
24	<p>Insert and fix the screws (48) according to the following tightening torque:</p> <ul style="list-style-type: none"> <li>• Mod. 102: Tab. 9.115</li> </ul> <p><b>! NOTICE!</b>  <b>Tighten the screws as shown in the diagram at “9.4.2.2 - Cross diagram for tightening screws”.</b></p>
25	Put the diaphragm unit in place (43, 44, 45, 46, 47).
26	Fit the lid (40).
27	<p>Insert and fix the screws (42) according to the following tightening torque:</p> <ul style="list-style-type: none"> <li>• Mod. 102: Tab. 9.115</li> </ul> <p><b>! NOTICE!</b>  <b>Tighten the screws as shown in the diagram at “9.4.2.2 - Cross diagram for tightening screws”.</b></p>

Tab. 9.149

**! WARNING!**

**Ensure that all parts have been fitted correctly.**

9.4.9.2 - PRESSURE SWITCH MOD. 103M/103MH

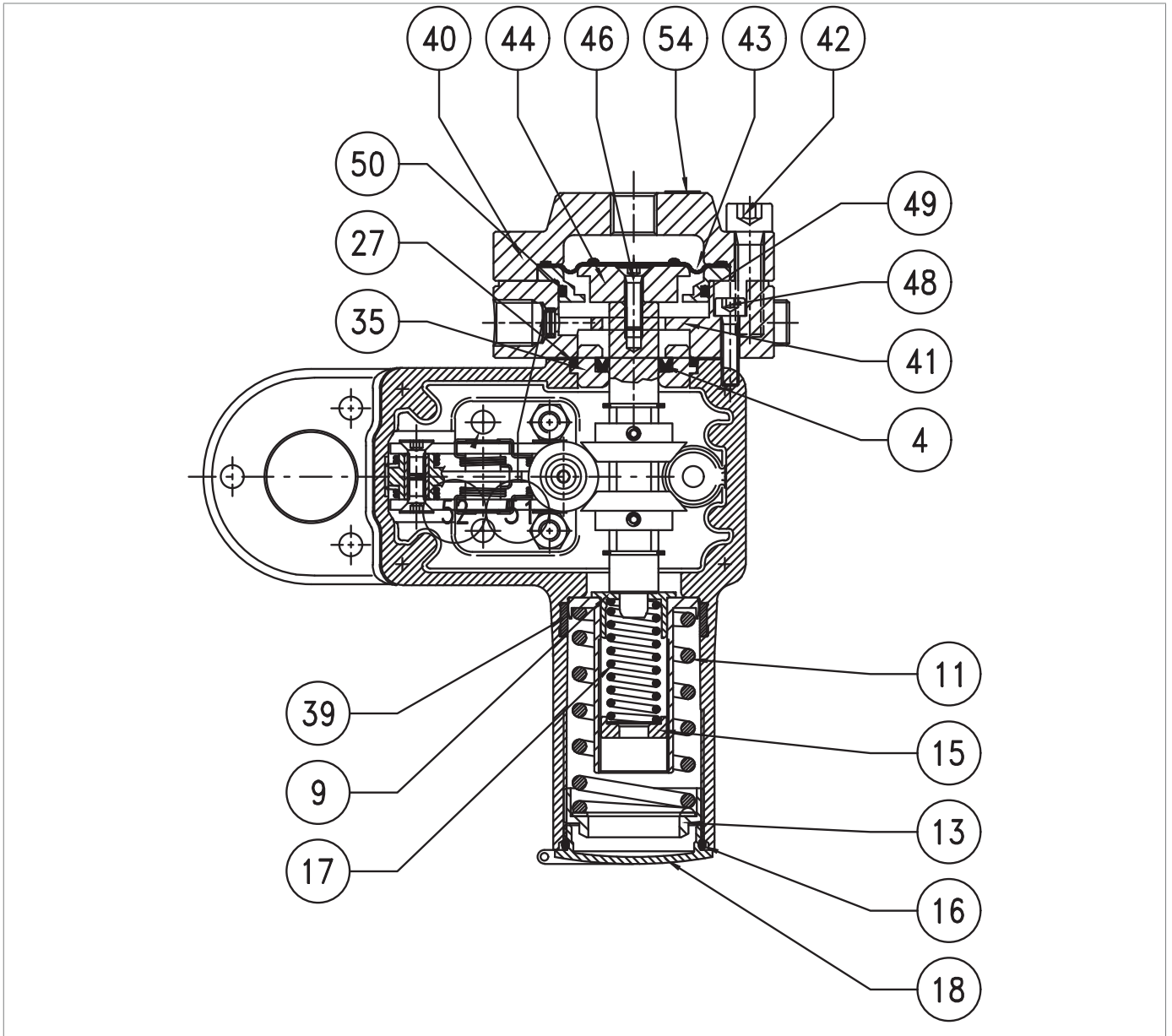







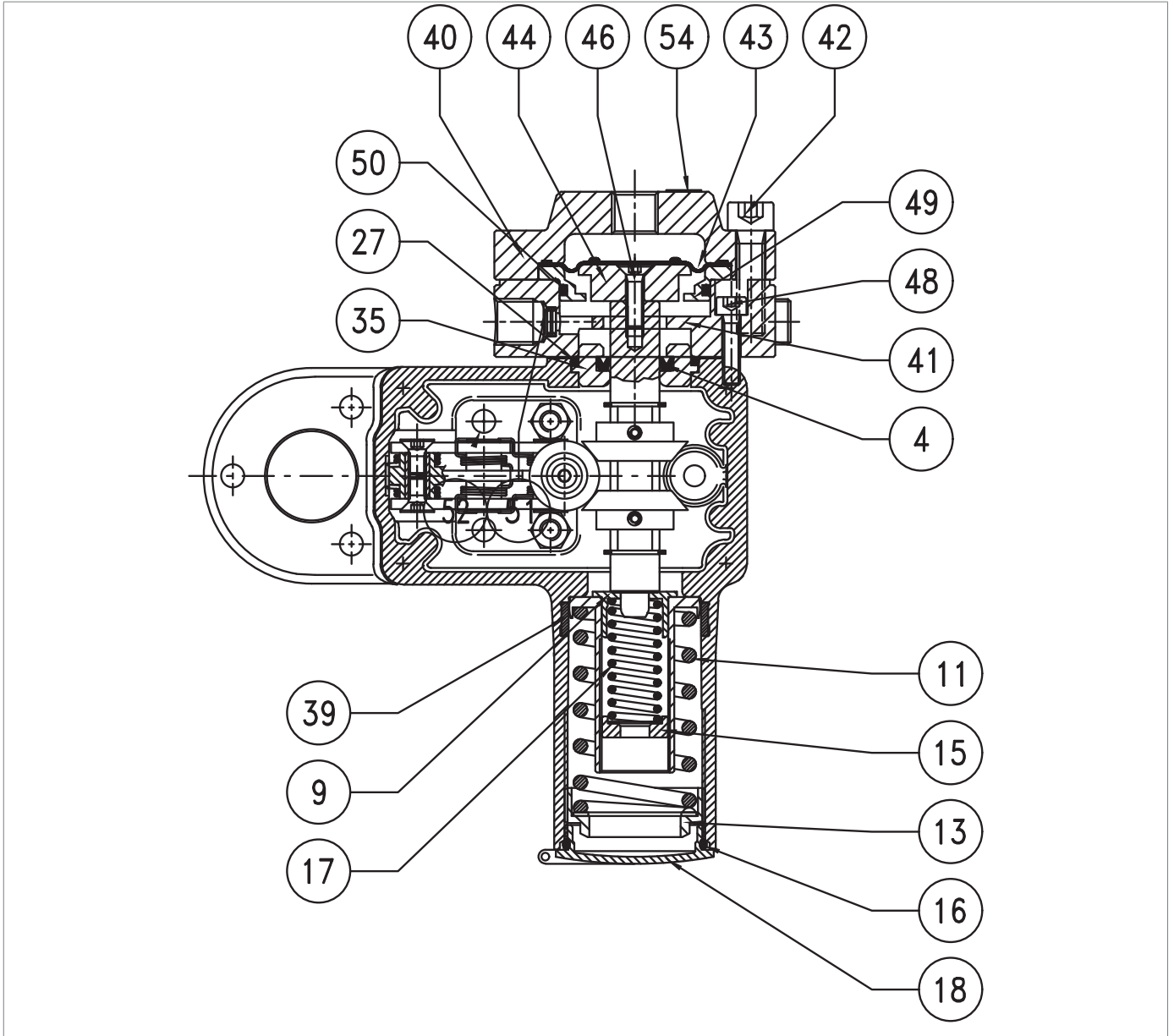







Fig. 9.76. Pressure switch Mod. 103M/103MH

Step	Action
1	Unscrew and remove the cap (18).
2	Remove the O-ring (16) from the cover (18) and replace it, lubricating it with synthetic grease. <div style="border: 1px solid black; padding: 2px;">  <b>NOTICE!</b>  <b>Before inserting the replacement O-ring, clean the retaining slots with a cleaning solution.</b> </div>
3	Completely release the spring (11) by adjusting the ring nut (13).
4	Completely release the minimum pressure spring (17) by adjusting the ring nut (15). <div style="border: 1px solid black; padding: 2px;">  <b>NOTICE!</b>  <b>The minimum spring may not be installed.</b> </div>
5	Remove the ring nut (13), the spring (11) and the spring support (17).
6	Remove the I/DWR ring (39) from the pressure switch sleeve and replace it, lubricating it with synthetic grease. <div style="border: 1px solid black; padding: 2px;">  <b>NOTICE!</b>  <b>Before fitting the replacement I/DWR ring, clean the retaining slots using a cleaning solution.</b> </div>
7	Undo and remove the screws (42).
8	Remove the upper cover (40).
9	Remove and replace the diaphragm (43), lubricating the lanyard with synthetic grease. <div style="border: 1px solid black; padding: 2px;">  <b>NOTICE!</b>  <b>Before inserting the replacement diaphragm, clean the retaining slots with a cleaning solution.</b> </div>
10	Undo and remove the screws (46).
11	Remove the ring (49).
12	Remove the O-ring (50) from the ring (49) and replace it. <div style="border: 1px solid black; padding: 2px;">  <b>NOTICE!</b>  <b>Before inserting the replacement O-ring, clean the retaining slots with a cleaning solution.</b> </div>
13	Undo and remove the screws (48).
14	Remove the lower lid (41).
15	Remove the bush (35).
16	Remove the O-ring (27) from the bush (35) and replace it, lubricating it with synthetic grease. <div style="border: 1px solid black; padding: 2px;">  <b>NOTICE!</b>  <b>Before inserting the replacement O-ring, clean the retaining slots with a cleaning solution.</b> </div>
17	Remove the U-shaped ring (4) from the bush (35) and replace it, lubricating it with synthetic grease. <div style="border: 1px solid black; padding: 2px;">  <b>NOTICE!</b>  <b>Before inserting the replacement U-ring, clean the retaining slots with a cleaning solution.</b> </div>



Pressure switch Mod. 103M/103MH

Step	Action
18	Position the bush (35) together with the O-ring (27). <div style="border: 1px solid black; padding: 5px;">  <b>NOTICE!</b>  <b>Before inserting the bush (35), lubricate the internal surface with silicone grease.</b> </div>
19	Remove the lower lid (41)
20	Insert and fix the screws (48) according to the following tightening torque: <ul style="list-style-type: none"> <li>Mod. 103: Tab. 9.116</li> </ul> <div style="border: 1px solid black; padding: 5px;">  <b>NOTICE!</b>  <ul style="list-style-type: none"> <li><b>Tighten the screws as shown in the diagram at “9.4.2.2 - Cross diagram for tightening screws”;</b></li> <li><b>Make sure there is a gasket between the lower cover and the pressure switch body.</b></li> </ul> </div>
21	Fit the diaphragm protection disc (44), then insert and secure the screw (46). <div style="border: 1px solid black; padding: 5px;">  <b>NOTICE!</b>  <b>Before inserting the screw (46), apply thread locking glue.</b> </div>
22	Insert and fix the screws (46) according to the following tightening torque: <ul style="list-style-type: none"> <li>Mod. 103: Tab. 9.116</li> </ul> <div style="border: 1px solid black; padding: 5px;">  <b>NOTICE!</b>  <ul style="list-style-type: none"> <li><b>Tighten the screws as shown in the diagram at “9.4.2.2 - Cross diagram for tightening screws”;</b></li> <li><b>Before inserting the screw (46), apply thread locking glue.</b></li> </ul> </div>
23	Fit the diaphragm (43).
24	Fit the lid (40).
25	Insert and fix the screws (42) according to the following tightening torque: <ul style="list-style-type: none"> <li>Mod. 103: Tab. 9.116</li> </ul> <div style="border: 1px solid black; padding: 5px;">  <b>NOTICE!</b>  <b>Tighten the screws as shown in the diagram at “9.4.2.2 - Cross diagram for tightening screws”.</b> </div>

Tab. 9.150

 **WARNING!**

Ensure that all parts have been fitted correctly.

9.4.9.3 - PRESSURE SWITCH MOD. 104M/104MH ÷ 105M/105MH

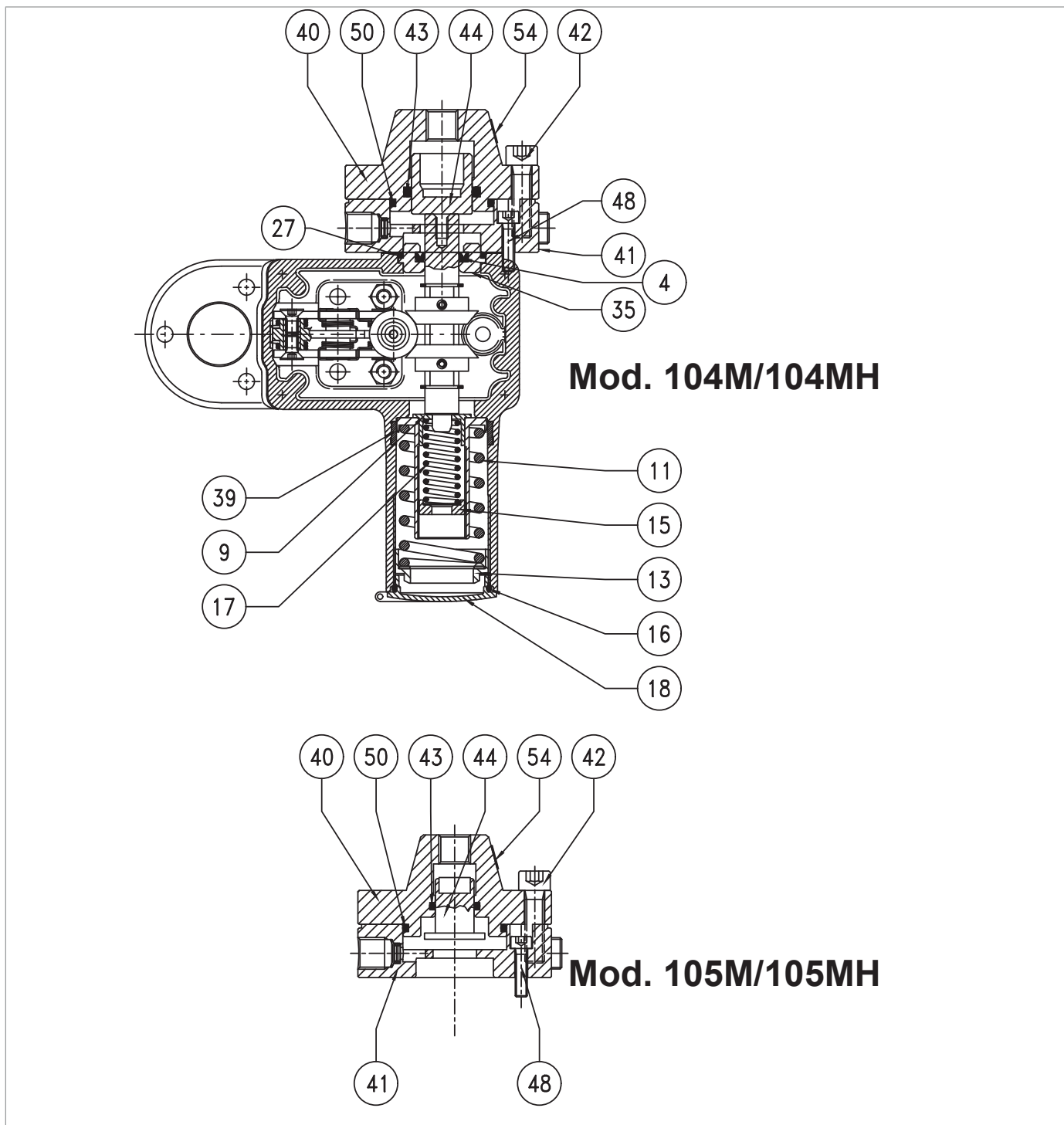
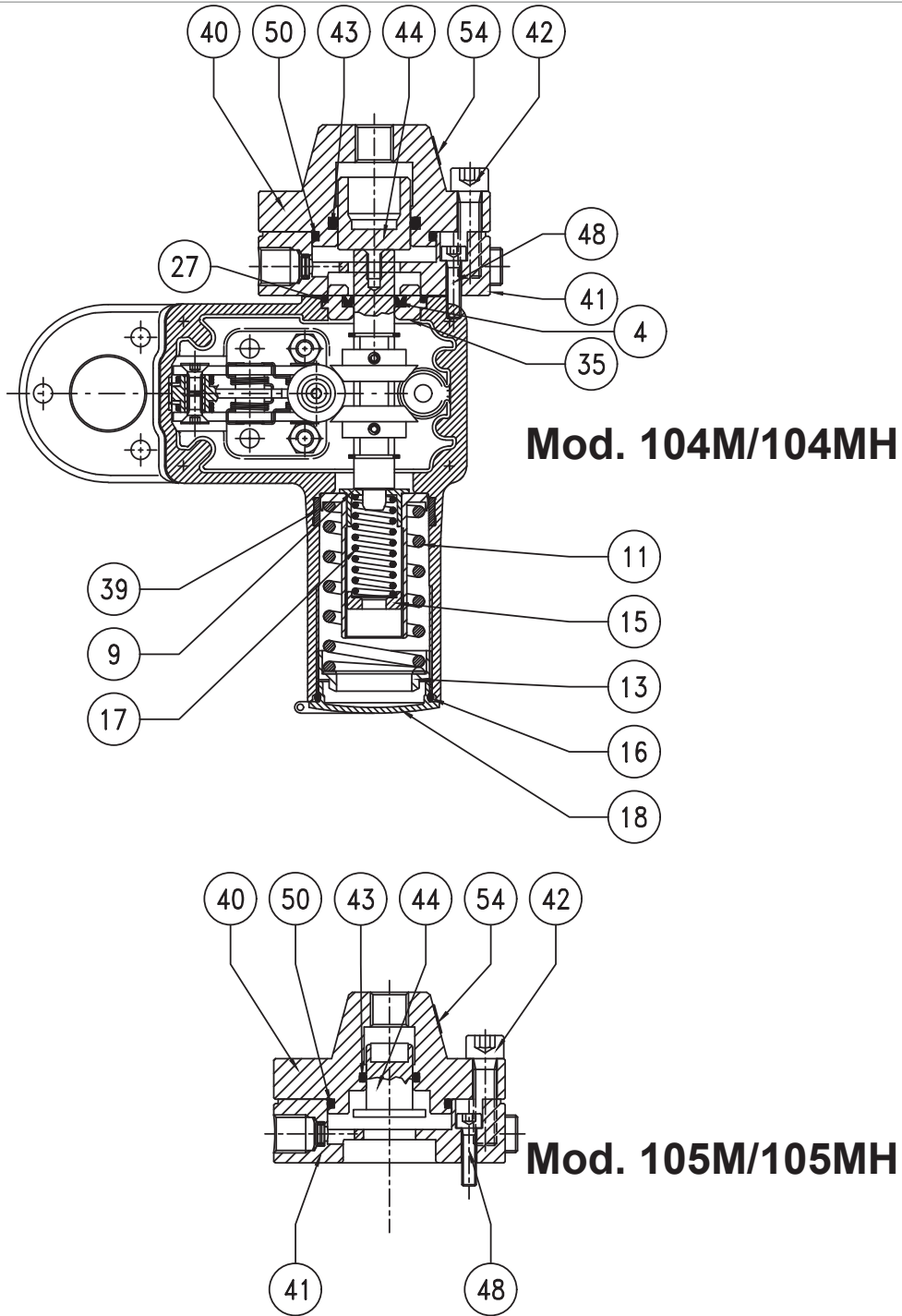





Fig. 9.77. Pressure switch Mod. 104M/104MH ÷ 105M/105MH

Step	Action
1	Unscrew and remove the cap (18).
2	Remove the O-ring (16) from the cover (18) and replace it, lubricating it with synthetic grease. <b>! NOTICE!</b> <b>Before inserting the replacement O-ring, clean the retaining slots with a cleaning solution.</b>
3	Completely release the spring (11) by adjusting the ring nut (13).
4	Completely release the minimum pressure spring (17) by adjusting the ring nut (15). <b>! NOTICE!</b> <b>The minimum spring may not be installed.</b>
5	Remove the ring nut (13), the spring (11) and the spring support (17).
6	Remove the I/DWR ring (39) from the pressure switch sleeve and replace it, lubricating it with synthetic grease. <b>! NOTICE!</b> <b>Before fitting the replacement I/DWR ring, clean the retaining slots using a cleaning solution.</b>
7	Undo and remove the screws (42).
8	Remove the upper cover (40) together with the piston (44).
9	Pull the piston (44) out of the upper cover (40).
10	Remove the O-rings (43, 50) from the upper cover (40) and replace them, lubricating them with synthetic grease. <b>! NOTICE!</b> <b>Before inserting the replacement O-rings, clean the retaining slots with a cleaning solution.</b>
11	Refit the piston (44) into the upper lid (40).
12	Undo and remove the screws (48).
13	Remove the lower lid (41).
14	Remove the bush (35).
15	Remove the O-ring (27) from the bush (35) and replace it, lubricating it with synthetic grease. <b>! NOTICE!</b> <b>Before inserting the replacement O-ring, clean the retaining slots with a cleaning solution.</b>
16	Remove the U-shaped ring (4) from the bush (35) and replace it, lubricating it with synthetic grease. <b>! NOTICE!</b> <b>Before inserting the replacement U-ring, clean the retaining slots with a cleaning solution.</b>
17	Position the bush (35) together with the O-ring (27). <b>! NOTICE!</b> <b>Before inserting the bush (35), lubricate the internal surface with silicone grease.</b>



Pressure switch Mod. 104M/104MH ÷ 105M/105MH

Step	Action
18	Fit the lower cover (41). <div style="border: 1px solid blue; padding: 2px;">  <b>NOTICE!</b>  <b>Make sure there is a gasket between the lower cover and the pressure switch body.</b> </div>
19	Insert and fix the screws (48) according to the following tightening torques: <ul style="list-style-type: none"> <li>• Mod. 104-105: Tab. 9.117</li> </ul> <div style="border: 1px solid blue; padding: 2px;">  <b>NOTICE!</b>  <b>Tighten the screws as shown in the diagram at “9.4.2.2 - Cross diagram for tightening screws”.</b> </div>
20	Fit the upper cover (40).
21	Insert and fix the screws (42) according to the following tightening torques: <ul style="list-style-type: none"> <li>• Mod. 104-105: Tab. 9.117</li> </ul> <div style="border: 1px solid blue; padding: 2px;">  <b>NOTICE!</b>  <b>Tighten the screws as shown in the diagram at “9.4.2.2 - Cross diagram for tightening screws”.</b> </div>

Tab. 9.151

 **WARNING!**

**Ensure that all parts have been fitted correctly.**

**9.4.10 - HB/97 BUILT-IN SLAM-SHUT VALVE MAINTENANCE PROCEDURE**

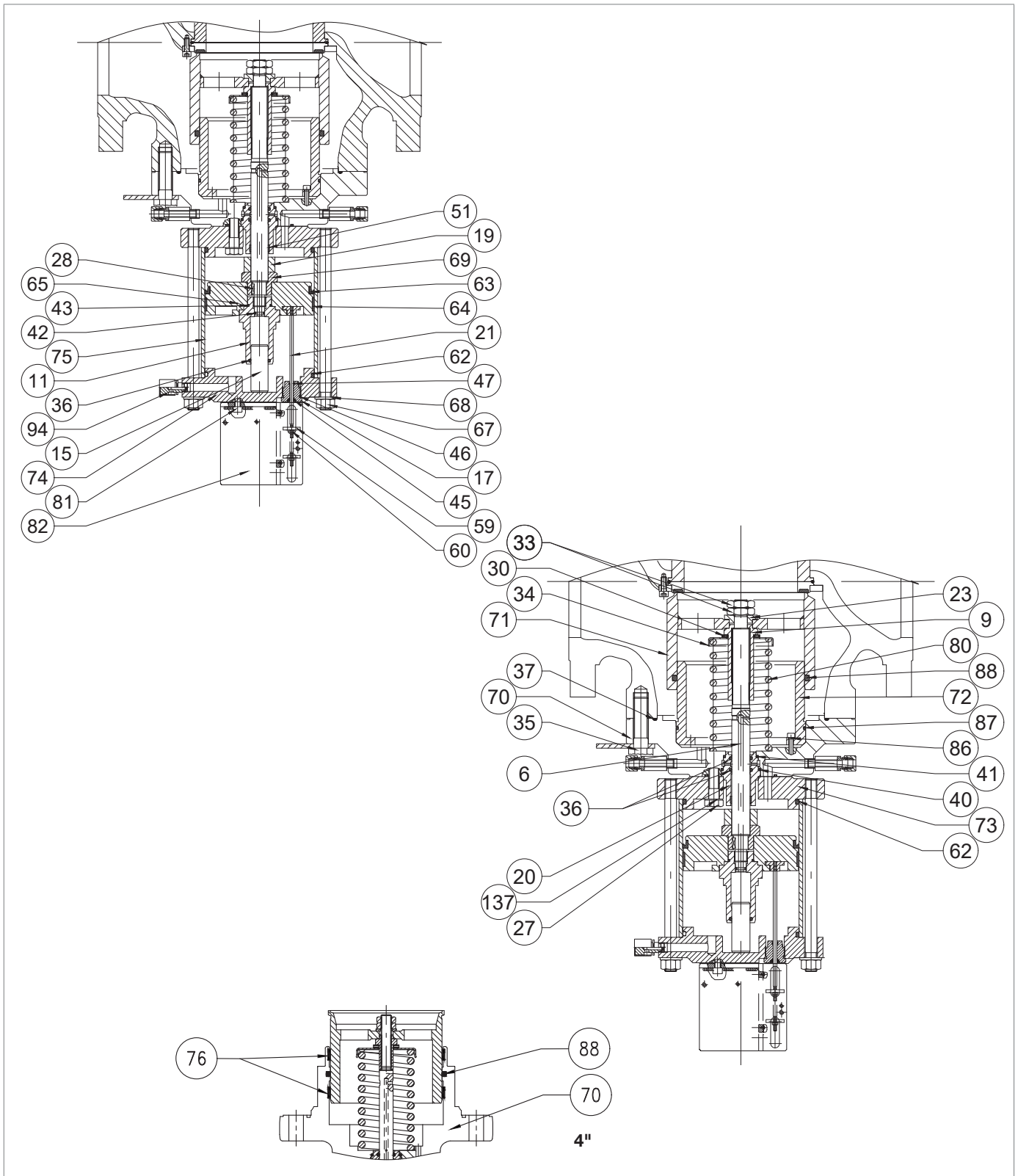







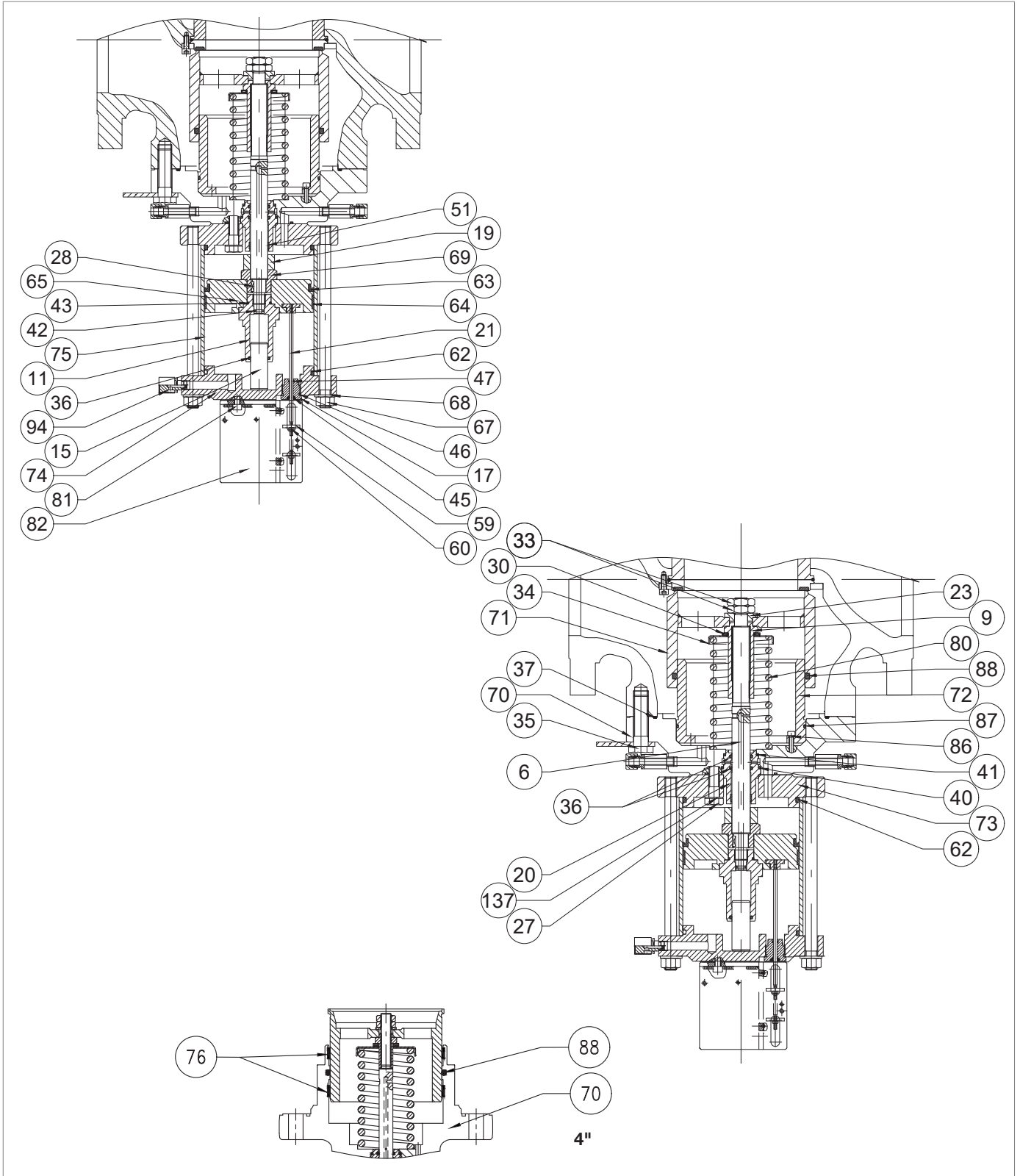

Fig. 9.78. HB/97 built-in slam-shut valve

Step	Action
1	 <b>WARNING!</b> <b>Check that the slam-shut valve is in the shut-off position.</b>
2	 <b>NOTICE!</b> <b>To disconnect the LINE OFF 2.0 device, refer to paragraph “9.4.9.1 - Pressure switch Mod. 102M/102MH”.</b>
3	Undo and remove the screws (81).
4	Remove the bracket (82).
5	Unscrew and remove the nut (59) together with the indicator disc (60).
6	Unscrew and remove the nut (17).
7	Pull out the indicator rod (21).
8	Remove the guide O-ring (45) from the nut (17) and replace it, lubricating it with synthetic grease.  <b>NOTICE!</b> <b>Before inserting the replacement guide ring, clean the retaining slots with a cleaning solution.</b>
9	Remove the O-rings (46, 47) from the nut (17) and replace them, lubricating them with synthetic grease.  <b>NOTICE!</b> <b>Before inserting the replacement O-rings, clean the retaining slots with a cleaning solution.</b>
10	Undo and remove the screws (35).  <b>NOTICE!</b> <b>In this step, support the built-in SB/97 slam-shut valve to prevent any falls.</b>
11	Remove the HB/97 built-in slam-shut valve and fit it vertically with the plug (71) on an anti-shock surface.
12	Unscrew and remove the nuts (67) together with the washers (68).
13	Remove the flange (74).  <b>NOTICE!</b> <b>Check that the vent (94) is not clogged by dirt.</b>
14	Remove the O-ring (62) from the flange (74) and replace it, lubricating it with synthetic grease.  <b>NOTICE!</b> <b>Before inserting the replacement O-ring, clean the retaining slots with a cleaning solution.</b>
15	Remove the plating (75).
16	Fit the HB/97 built-in slam-shut valve sideways.
17	Unscrew and remove the nuts (33) together with the washer (23).
18	Remove the plug (71) and place it on an anti-shock surface.



HB/97 built-in slam-shut valve

Step	Action
19	<p><b>ONLY VALID FOR 4"</b> Remove the O-ring (88) from the plug (70) and replace it, lubricating it with synthetic grease.</p> <p><b>NOTICE!</b> <b>Before inserting the O-ring, clean the retaining slots with a cleaning solution.</b></p>
20	<p><b>ONLY VALID FOR 4"</b> Remove the I/DWR rings (76) from the plug guide (70) and replace it, lubricating it with synthetic grease.</p> <p><b>NOTICE!</b> <b>Before inserting the I/DWR rings, clean the retaining slots with a cleaning solution.</b></p>
21	<p>Remove the O-ring (88) from the plug (71) and replace it, lubricating it with synthetic grease.</p> <p><b>NOTICE!</b> <b>Before inserting the replacement O-ring, clean the retaining slots with a cleaning solution.</b></p>
22	<p>While keeping the nut (69) in place, unscrew and remove the lock nut (9).</p> <p><b>WARNING!</b> <b>By unscrewing the lock nut (9), the spring (80) is released.</b></p>
23	Remove the radial bearing (30).
24	Remove the spring support (34) and the spring (80).
25	While keeping the nut (69) in place, unscrew and remove the balancing piston guide (11).
26	Remove the balancing piston (15) from the balancing piston guide (11).
27	<p>Remove the O-rings (36, 43) from the balancing piston guide (11) and replace them, taking care to lubricate them with synthetic grease.</p> <p><b>NOTICE!</b> <b>Before inserting the replacement O-rings, clean the retaining slots with a cleaning solution.</b></p>
28	Fit the balancing piston (15) from the balancing piston guide (11).
29	Take out the piston (65).
30	<p>Remove the U-shaped ring (63) from the bush (65) and replace it, lubricating it with synthetic grease.</p> <p><b>NOTICE!</b></p> <ul style="list-style-type: none"> <li>• <b>Before inserting the replacement U-ring, clean the retaining slots with a cleaning solution.</b></li> <li>• <b>The concave part must face the flange (73).</b></li> </ul>
31	<p>Remove the I/DWR ring (64) from the piston (65) and replace it, lubricating it with synthetic grease.</p> <p><b>NOTICE!</b> <b>Before inserting the replacement I/DWR ring, clean the retaining slots with a cleaning solution.</b></p>
32	Take out the nut (69).
33	<p><b>ONLY VALID FOR 6" ÷ 10"</b> Remove the spacer (19).</p>

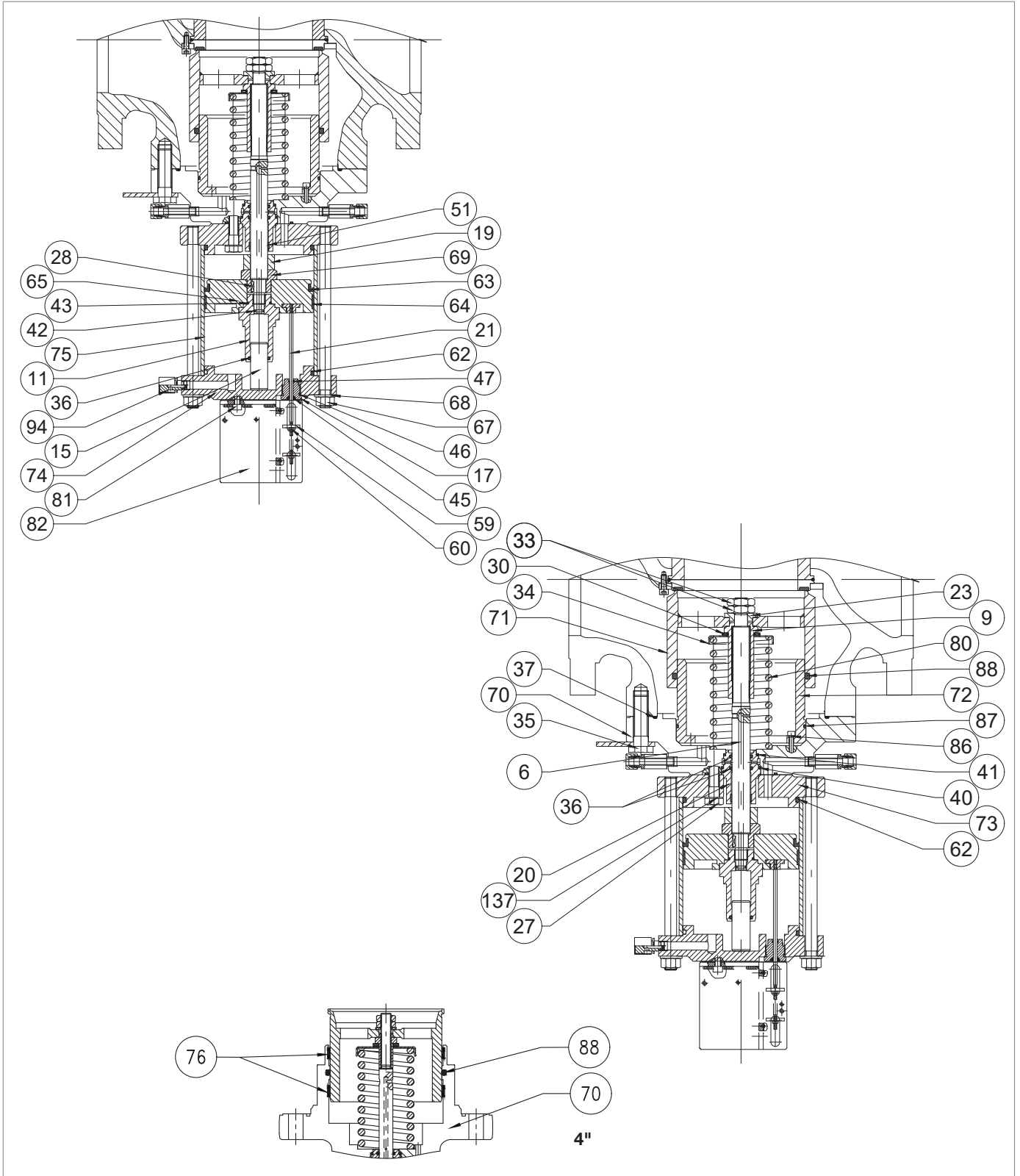

HB/97 built-in slam-shut valve

Step	Action
34	Undo and remove the screws (27) together with the washer (137).
35	Remove the flange (73).
36	Remove the O-ring (62) from the flange (73) and replace it, lubricating it with synthetic grease. <b>! NOTICE!</b> <b>Before inserting the replacement O-ring, clean the retaining slots with a cleaning solution.</b>
37	Remove the stem guide (20) together with the stem (6) and the key (28).
38	Remove the stem (6) from the stem guide (20).
39	Remove the I/DWR ring (51) from the stem guide (20) and replace it, lubricating it with synthetic grease. <b>! NOTICE!</b> <b>Before fitting the replacement I/DWR ring, clean the retaining slots using a cleaning solution.</b>
40	Remove the O-rings (36) from the stem guide (20) and replace them, lubricating them with synthetic grease. <b>! NOTICE!</b> <b>Before inserting the replacement O-rings, clean the retaining slots with a cleaning solution.</b>
41	Remove the O-rings (40, 41) from the stem guide (20) and replace them, lubricating them with synthetic grease. <b>! NOTICE!</b> <b>Before inserting the replacement O-rings, clean the retaining slots with a cleaning solution.</b>
42	Remove the O-ring (42) from the stem (6) and replace it, lubricating it with synthetic grease. <b>! NOTICE!</b> <b>Before inserting the replacement O-ring, clean the retaining slots with a cleaning solution.</b>
43	<b>VALID ONLY FOR 6"- 10"</b> Undo and remove the screws (86).
44	<b>VALID ONLY FOR 6"- 10"</b> Take out the plug guide (72). <b>! NOTICE!</b> <b>In this step, tighten some M6x50 screws into the threaded holes of the plug guide to remove it vertically.</b>
45	Remove the screws M6x50.
46	<b>VALID ONLY FOR 6"- 10"</b> Remove the O-ring (87) from the plug guide (72) and replace it, lubricating it with synthetic grease. <b>! NOTICE!</b> <b>Before inserting the replacement O-ring, clean the retaining slots with a cleaning solution.</b>
47	<b>VALID ONLY FOR 6"- 10"</b> Put the plug guide (72) in place.

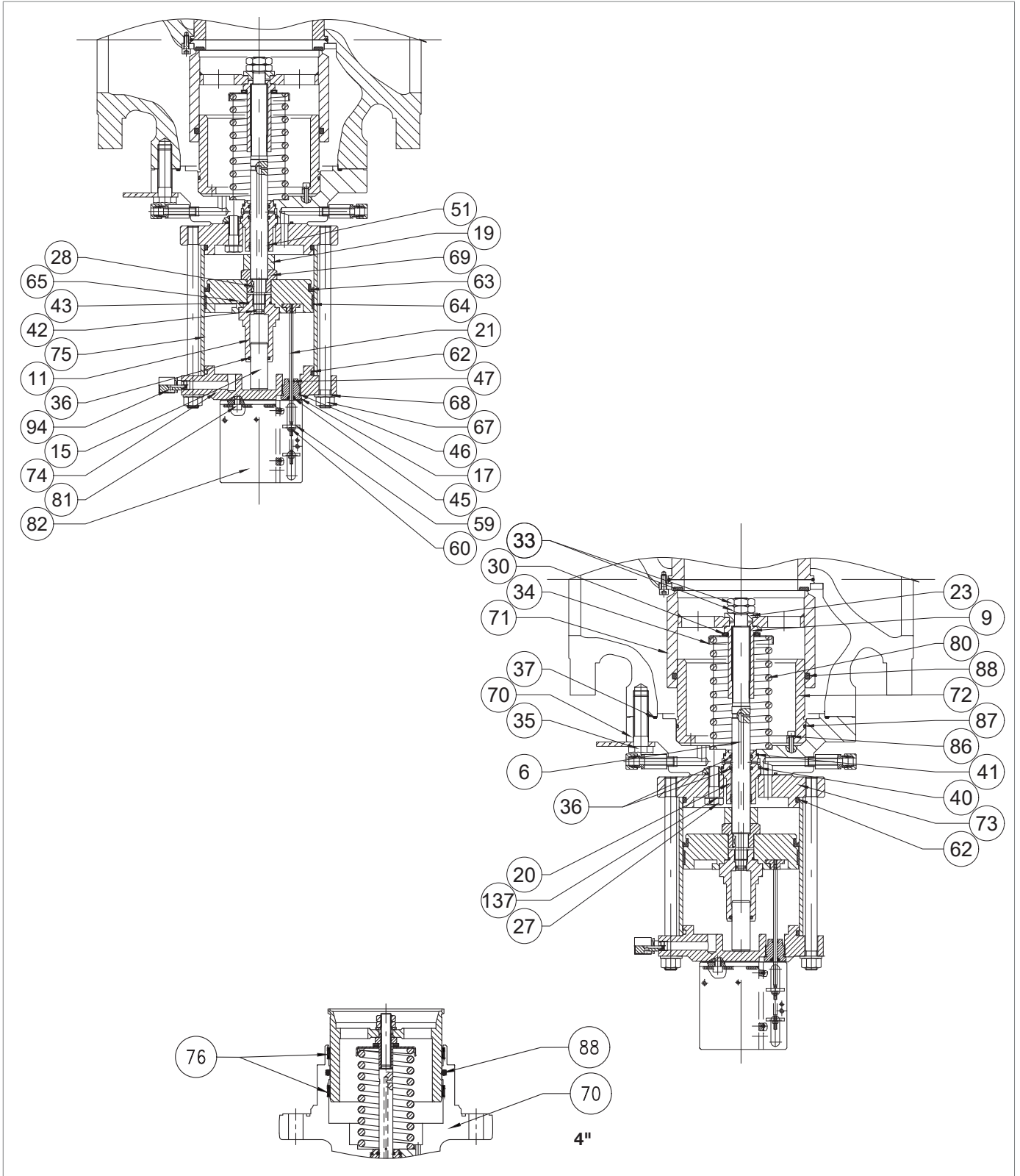

HB/97 built-in slam-shut valve

Step	Action
48	<p><b>VALID ONLY FOR 6" - 10"</b></p> <p>Insert and fix the screws (86) according to the following tightening torques:</p> <ul style="list-style-type: none"> <li>• 6": Tab. 9.119</li> <li>• 8": Tab. 9.120</li> <li>• 10": Tab. 9.121</li> </ul> <p><b>NOTICE!</b></p> <p><b>Tighten the screws as shown in the diagram at "9.4.2.2 - Cross diagram for tightening screws".</b></p>
49	<p>Insert the stem (6) together with the key (28) in the stem guide (20).</p> <p><b>NOTICE!</b></p> <p><b>Clean and lubricate the stem surface with silicone grease; make sure that the key (28) is in the correct position in the stem (6).</b></p>
50	<p>Insert the stem guide (20) together with the stem (6) into the plug guide (70).</p>
51	<p>Fit the flange (73).</p> <p><b>NOTICE!</b></p> <p><b>Match the chamber pressurisation hole with the plug guide hole (70)</b></p>
52	<p>Insert and fix the screws (27) together with the washers (137) according to the following tightening torques:</p> <ul style="list-style-type: none"> <li>• 4": Tab. 9.118</li> <li>• 6": Tab. 9.119</li> <li>• 8": Tab. 9.120</li> <li>• 10": Tab. 9.121</li> </ul> <p><b>NOTICE!</b></p> <p><b>Tighten the screws as shown in the diagram at "9.4.2.2 - Cross diagram for tightening screws".</b></p>
53	<p><b>VALID ONLY FOR 6" - 10"</b></p> <p>Insert the spacer (19).</p>
54	<p>Insert the nut (69).</p> <p><b>NOTICE!</b></p> <p><b>Make sure that the key (28) is present and correctly positioned in the stem (6).</b></p>
55	<p>Fit the piston (65).</p>
56	<p>Keeping the nut (69) in position, insert and fix the balancing piston guide (11) according to the tightening torques:</p> <ul style="list-style-type: none"> <li>• 4": Tab. 9.118</li> <li>• 6": Tab. 9.119</li> <li>• 8": Tab. 9.120</li> <li>• 10": Tab. 9.121</li> </ul>
57	<p>Position the spring (80), together with the spring support (34) and the radial bearing (30).</p>
58	<p>Keeping the nut (69) in position, insert and fix the nut (9) according to the following tightening torques:</p> <ul style="list-style-type: none"> <li>• 4": Tab. 9.118</li> <li>• 6": Tab. 9.119</li> <li>• 8": Tab. 9.120</li> <li>• 10": Tab. 9.121</li> </ul>
59	<p>Fit the plug (71).</p>

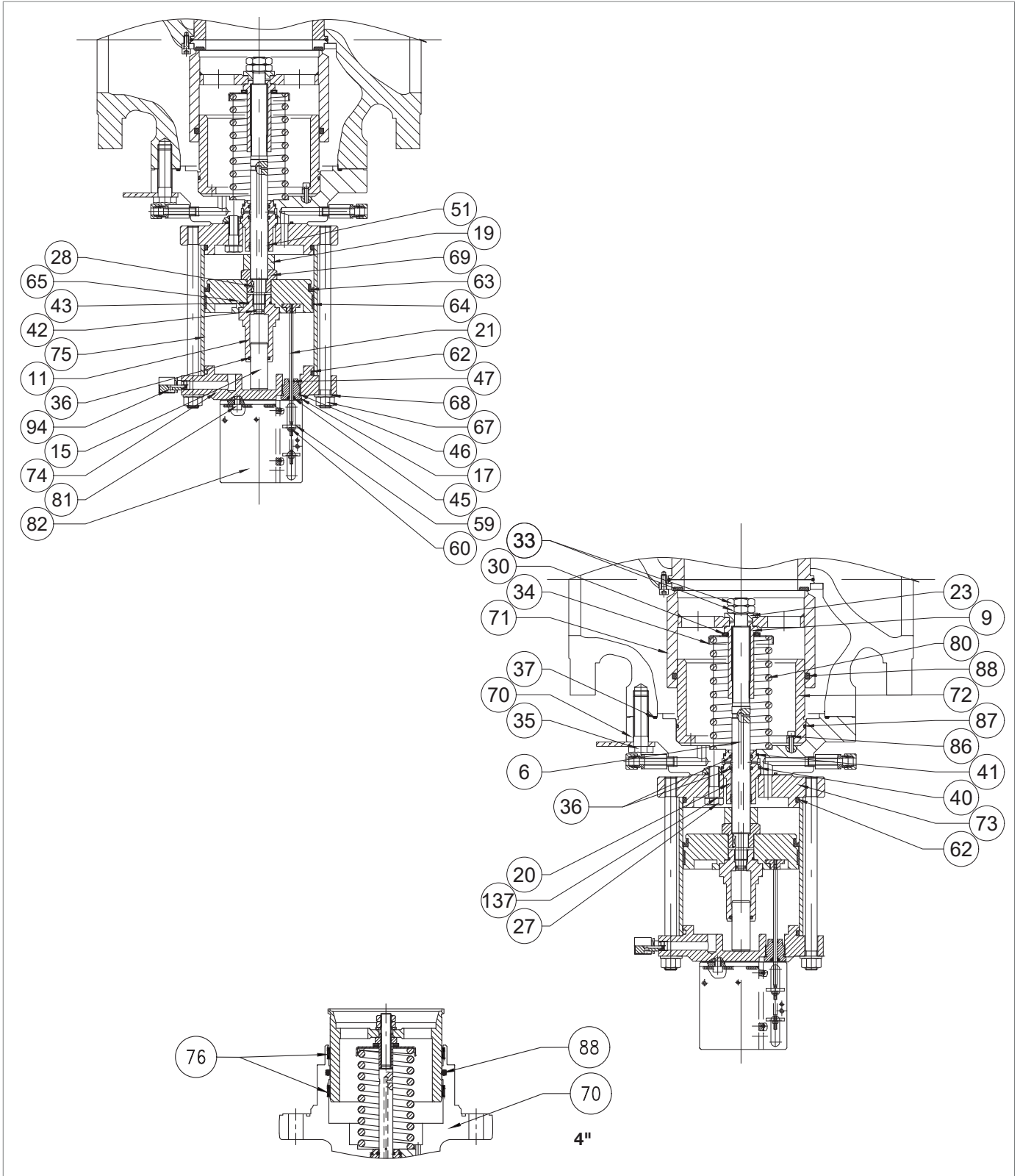

*HB/97 built-in slam-shut valve*

Step	Action
60	<p>Fit the nut (23) together with the nuts (33) and fix them according to the following tightening torques:</p> <ul style="list-style-type: none"> <li>• 4": Tab. 9.118</li> <li>• 6": Tab. 9.119</li> <li>• 8": Tab. 9.120</li> <li>• 10": Tab. 9.121</li> </ul> <p><b>NOTICE!</b> <b>Before fitting the external nut (33), apply some thread locking glue.</b></p>
61	<p>Fit the plating (75).</p> <p><b>NOTICE!</b> <b>Before refitting the plating (75), clean and lubricate the internal surface with silicone grease.</b></p>
62	<p>Fit the upper flange (74).</p> <p><b>NOTICE!</b> <b>The stroke indicator hole must be perpendicular to the flow and visible in the in-line installation.</b></p>
63	<p>Insert and fix the nuts (67) according to the following tightening torques:</p> <ul style="list-style-type: none"> <li>• 4": Tab. 9.118</li> <li>• 6": Tab. 9.119</li> <li>• 8": Tab. 9.120</li> <li>• 10": Tab. 9.121</li> </ul>
64	<p>Remove the O-ring (37) from the flange (70) and replace it, taking care to lubricate it with synthetic grease.</p> <p><b>NOTICE!</b> <b>Before inserting the replacement O-ring, clean the retaining slots with a cleaning solution.</b></p>
65	<p>Put the HB/97 built-in slam-shut valve back in place.</p> <p><b>NOTICE!</b> <b>During this step, support the slam-shut device to prevent any falls.</b></p>
66	<p>Insert and fix the screws (35).</p> <p><b>NOTICE!</b> <b>Tighten the screws as shown in the diagram at "9.4.2.2 - Cross diagram for tightening screws".</b></p>
67	<p>Insert the indicator rod (21).</p> <p><b>NOTICE!</b> <b>The rod must be fitted into the slot in the piston (65).</b></p>
68	<p>Insert and fix the screws (17).</p>
69	<p>Put the bracket (82) in place.</p>
70	<p>Insert and fix the screws (81) according to the following tightening torques:</p> <ul style="list-style-type: none"> <li>• 4": Tab. 9.118</li> <li>• 6": Tab. 9.119</li> <li>• 8": Tab. 9.120</li> <li>• 10": Tab. 9.121</li> </ul> <p><b>NOTICE!</b> <b>Tighten the screws as shown in the diagram at "9.4.2.2 - Cross diagram for tightening screws".</b></p>

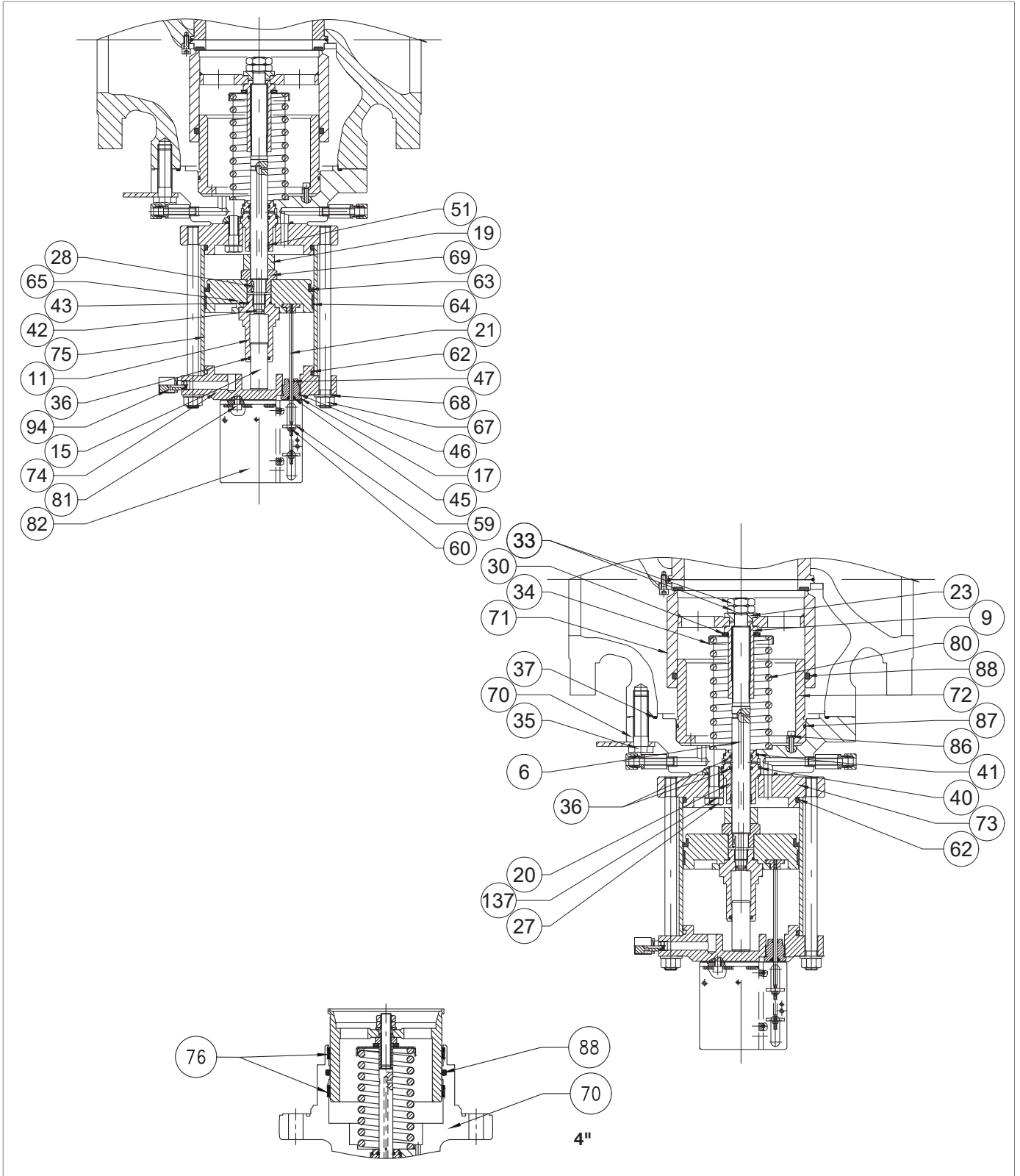

HB/97 built-in slam-shut valve

Step	Action
71	Fit and set the indicator washer (59) to "0".
72	Insert and fix the screws (60).
73	 <b>NOTICE!</b> To reconnect the LINE OFF 2.0 device, please refer to paragraph 9.4.12.1, Tab. 9.159.

Tab. 9.152

 **WARNING!**

**Ensure that all parts have been fitted correctly.**

**9.4.11 - LINE OFF 2.0 MAINTENANCE PROCEDURE**

**9.4.11.1 - LINE OFF 2.0 DISCONNECTION**

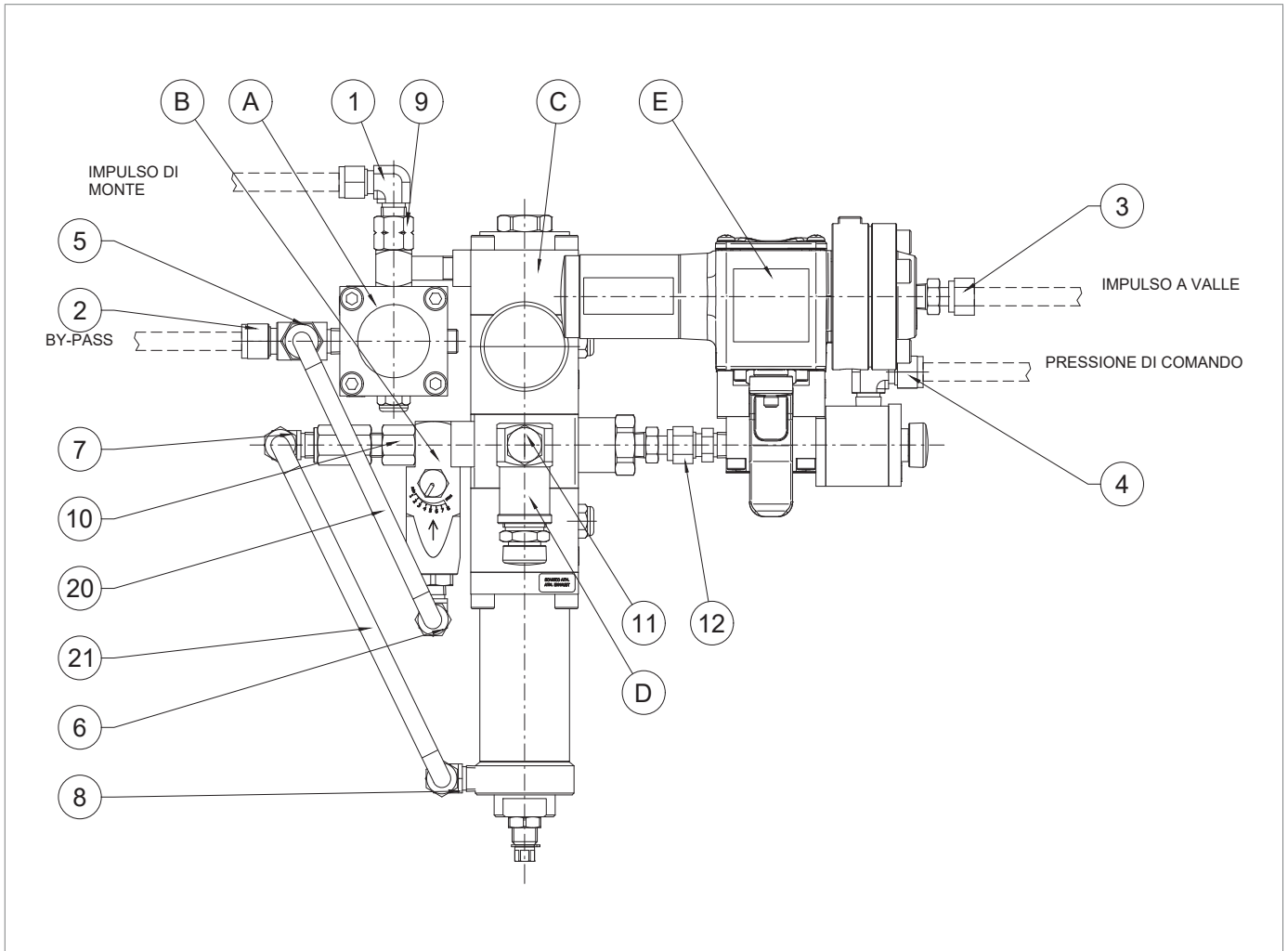

Fig. 9.79. LINE OFF 2.0

To disconnect the LINE OFF 2.0, proceed as described at Tab. 9.153:

Step	Action
1	Disconnect the pipes from the fittings (1, 2, 3, 4).
2	Unscrew and remove the fixing screw to disconnect the LINE OFF 2.0.
3	Disconnect the pipe (20) from the fittings (5, 6).
4	Disconnect the pipe (21) from the fittings (7, 8).
5	Remove assembly "A" (bypass <b>device HP2/2</b> ) and adjust the fitting (9).
6	Remove assembly "B" (throttle valve <b>AR100</b> ) and adjust the fitting (10).
7	Remove assembly "D" (safety valve <b>VS/FI</b> ) and adjust the fitting (11).
8	Remove assembly "E" (valve <b>3/2</b> and control pressure switch) from assembly "C" (regulator <b>R44/SS</b> ) and adjust the fitting (12).

Tab. 9.153

9.4.11.2 - HP2/2 BYPASS DEVICE

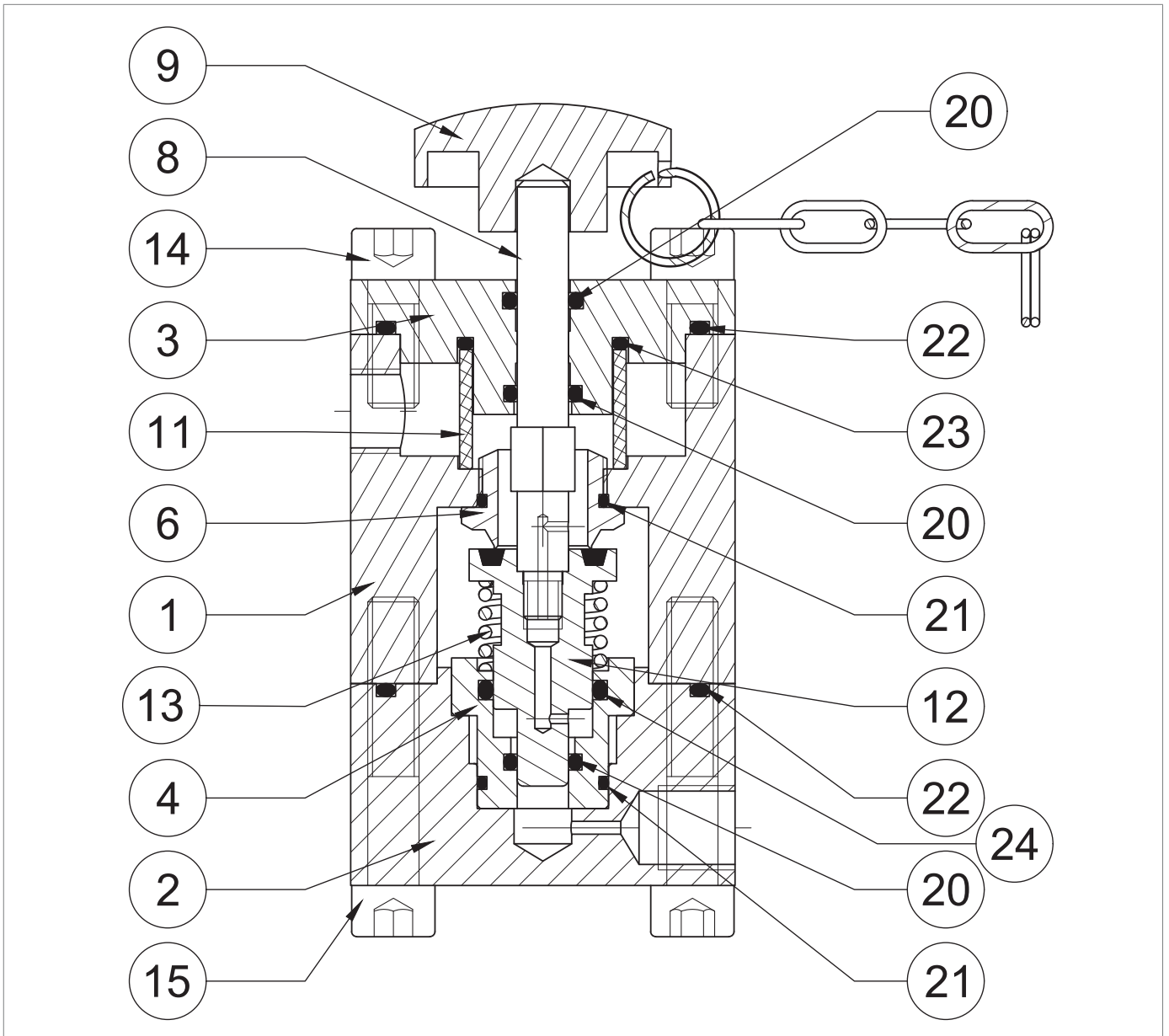







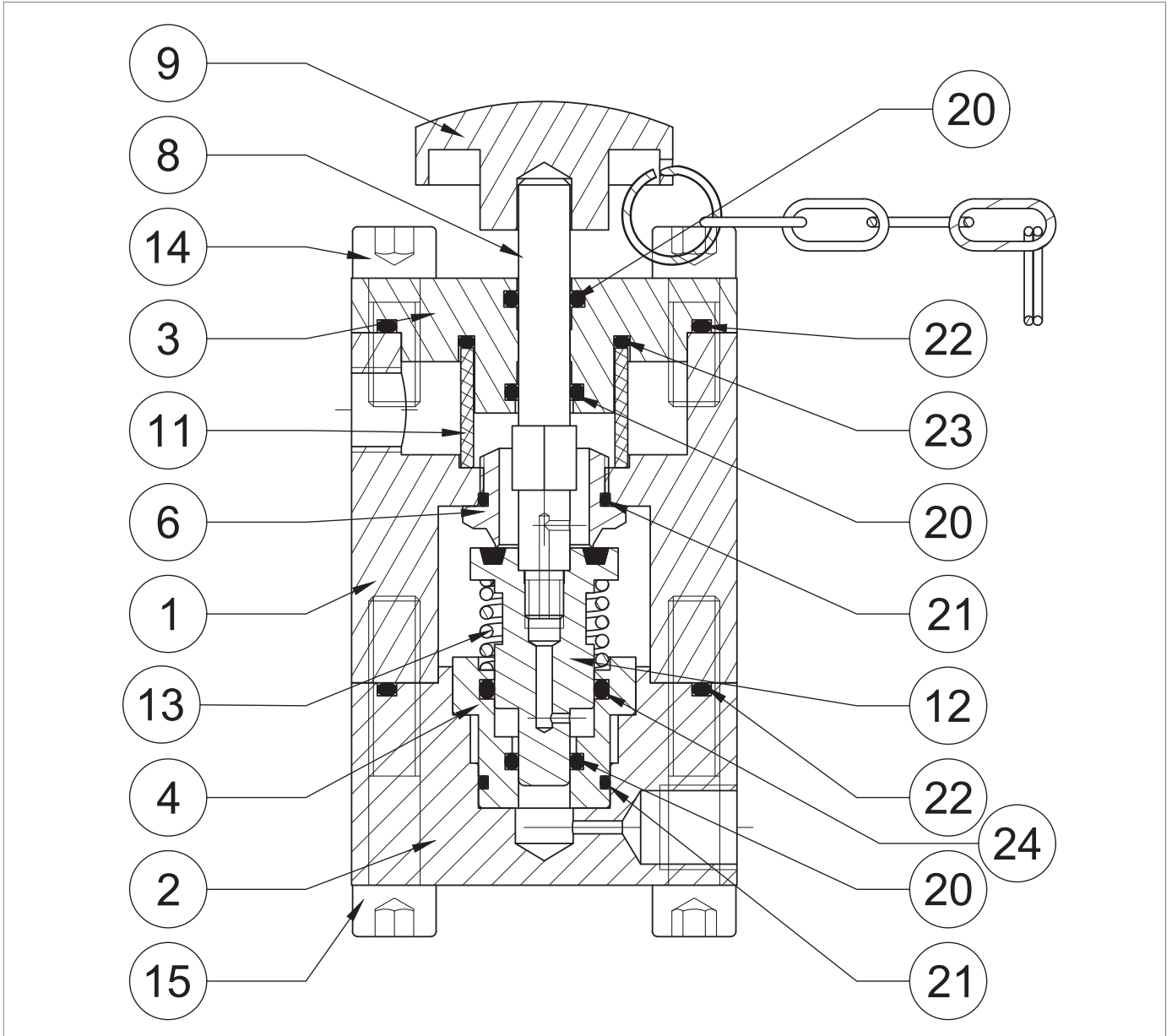

Fig. 9.80. HP2/2 bypass device

Step	Action
1	Remove the knob (9).
2	Undo and remove the screws (15).
3	Remove the cover (2) together with the bush (4), spring (13), plug (12) and stem (8).
4	Remove the bush (4), together with the spring (13), plug (12), stem (8) from the cover (2).
	Remove the O-ring (22) from the cover (2) and replace it, lubricating it with synthetic grease.
5	 <b>NOTICE!</b> <b>Before inserting the replacement O-ring, clean the retaining slots with a cleaning solution.</b>
6	Fit the plug (12) together with the stem (8).
7	Separate the stem (8) from the plug (12).
8	Replace the plug (12).
	Remove the O-rings (20, 21, 24) from the bush (4) and replace them, lubricating them with synthetic grease.
9	 <b>NOTICE!</b> <b>Before inserting the replacement O-rings, clean the retaining slots with a cleaning solution.</b>
	Undo and remove the screws (6).
10	 <b>NOTICE!</b> <b>Attention do not to ruin the seat profile during this step.</b>
	Remove the O-ring (21) from the seat (6) and replace it, lubricating it with synthetic grease.
11	 <b>NOTICE!</b> <b>Before inserting the replacement O-ring, clean the retaining slots with a cleaning solution.</b>
12	Undo and remove the screws (14).
13	Remove the flange (3).
	Remove the O-rings (22, 23) from the flange (3) and replace them, lubricating them with synthetic grease.
14	 <b>NOTICE!</b> <b>Before inserting the replacement O-rings, clean the retaining slots with a cleaning solution.</b>
	Remove the O-rings (20) from the flange (3) and replace them, lubricating them with synthetic grease.
15	 <b>NOTICE!</b> <b>Before inserting the replacement O-rings, clean the retaining slots with a cleaning solution.</b>
16	Remove and replace the filter (11).
17	Put the flange (3) back in place.
	Insert and fix the screws (14) according to the following tightening torque:
	<ul style="list-style-type: none"> <li>• HP2/2: Tab. 9.123</li> </ul>
18	 <b>NOTICE!</b> <b>Tighten the screws as shown in the diagram at “9.4.2.2 - Cross diagram for tightening screws”.</b>



HP2/2 bypass device

Step	Action
19	Fit and fix the seat (6) in the body (1). <b>NOTICE!</b> <b>Care must be taken not to ruin the seat profile during this step.</b>
20	Fit the bush (4) in the cover (2).
21	Screw the stem (8) into the plug (12). <b>NOTICE!</b> <b>Before fitting the stem (8), apply thread locking glue.</b>
22	Fit the spring (13).
23	Fit the plug (12) together with the stem (8) into the bush (4).
24	Fit the cover (2) together with the bush (4).
25	Insert and fix the screws (15) according to the following tightening torque: • HP2/2: Tab. 9.123 <b>NOTICE!</b> <b>Tighten the screws as shown in the diagram at “9.4.2.2 - Cross diagram for tightening screws”.</b>

Tab. 9.154

**WARNING!**

**Ensure that all parts have been fitted correctly.**

9.4.11.3 - AR100 THROTTLE VALVE

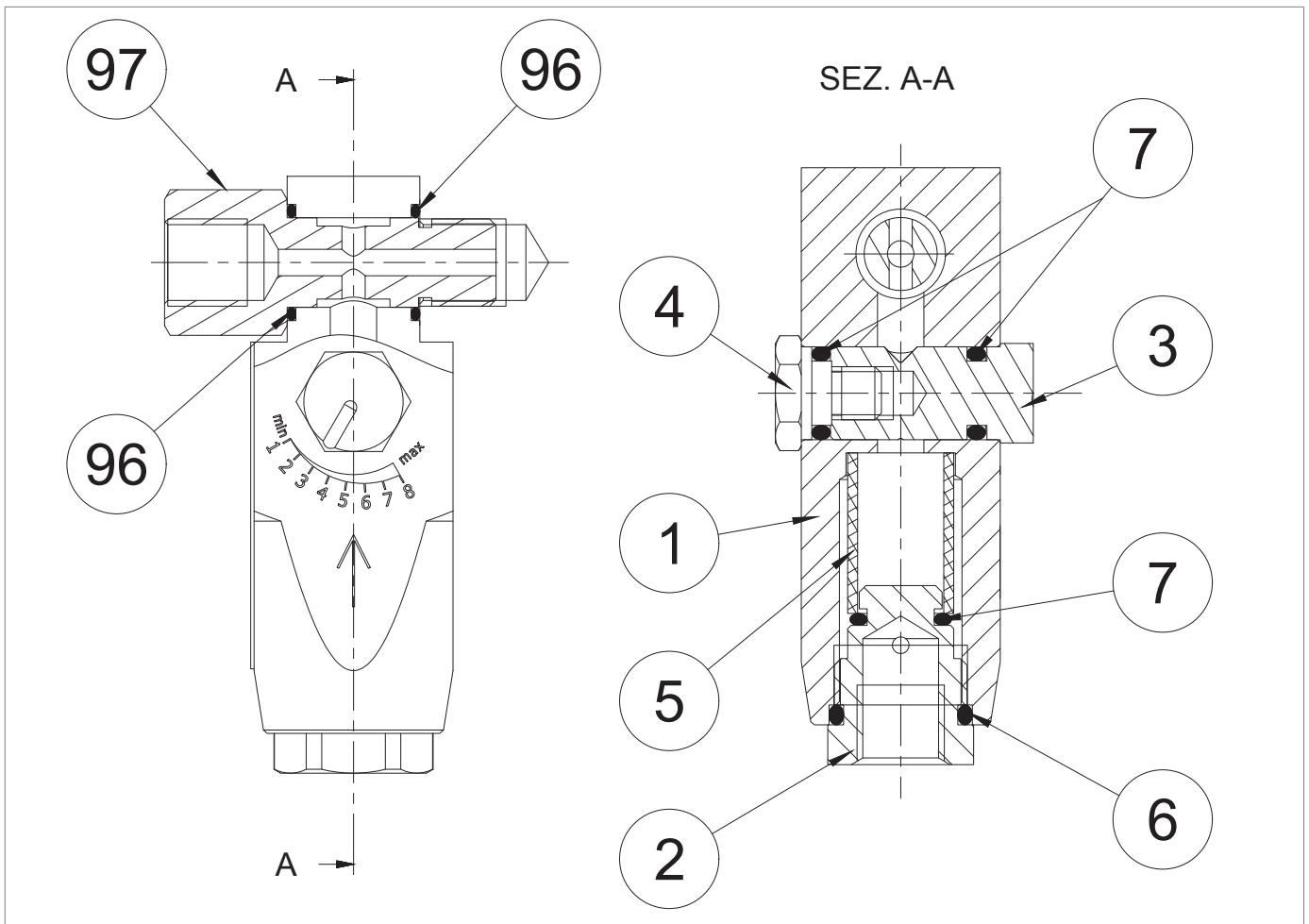

Fig. 9.81. AR100 throttle valve

Step	Action
1	Undo and remove the locking screw (97).
2	Remove the O-rings (96) from the AR100 throttle valve body (1) and replace them, lubricating them with synthetic grease. <b>NOTICE!</b> <b>Before inserting the replacement O-rings, clean the retaining slots with a cleaning solution.</b>
3	Undo and remove the locking screw (4).
4	Remove the O-ring (7) from the shut-off screw (4) and replace it, lubricating it with synthetic grease. <b>NOTICE!</b> <b>Before inserting the replacement O-ring, clean the retaining slots with a cleaning solution.</b>
5	Remove the adjusting screw (3).
6	Remove the O-ring (7) from the adjusting screw (3) and replace it, lubricating it with synthetic grease. <b>NOTICE!</b> <b>Before inserting the replacement O-ring, clean the retaining slots with a cleaning solution.</b>
7	Unscrew and remove the cap (2).
8	Remove the O-rings (6, 7) from the cap (2) and replace them, lubricating them with synthetic grease. <b>NOTICE!</b> <b>Before inserting the replacement O-rings, clean the retaining slots with a cleaning solution.</b>
9	Remove and replace the filter (5).
10	Fit and fix the cap (2) according to the following tightening torque: • AR100: Tab. 9.124 <b>NOTICE!</b> <b>Take care not to damage the O-rings (6, 7).</b>
11	Insert the adjusting screw (3), taking care not to damage the O-ring (7).
12	Fit and fix the shut-off screw (4) according to the following tightening torque: • AR100: Tab. 9.124 <b>NOTICE!</b> <b>Take care not to damage the O-ring (7).</b>
13	Insert the locking screw (97) with the valve ports in line with the AR100 throttle valve (1) body.

Tab. 9.155

**WARNING!**

Ensure that all parts have been fitted correctly.

9.4.11.4 - PRESSURE REGULATOR R44/SS

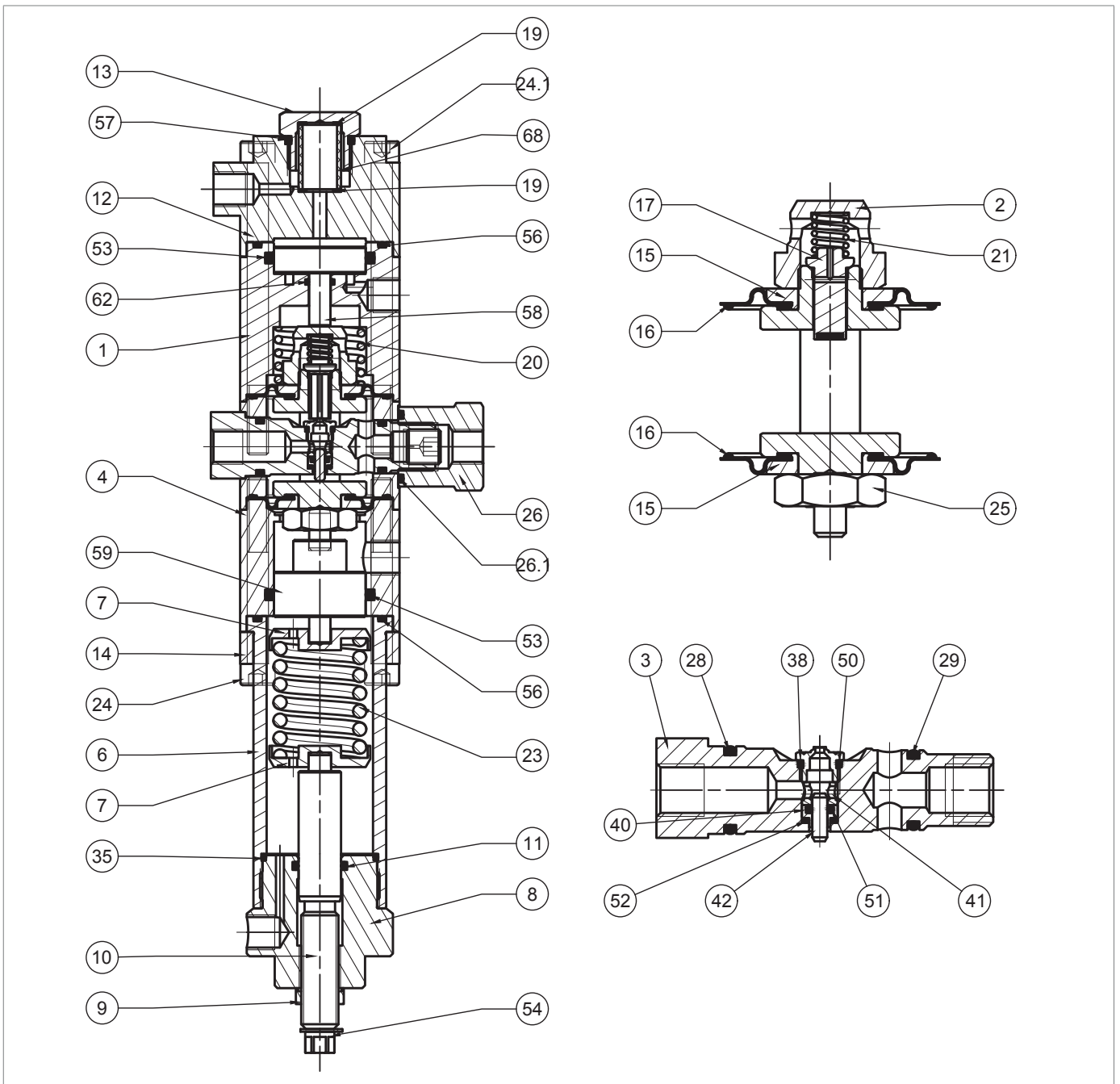
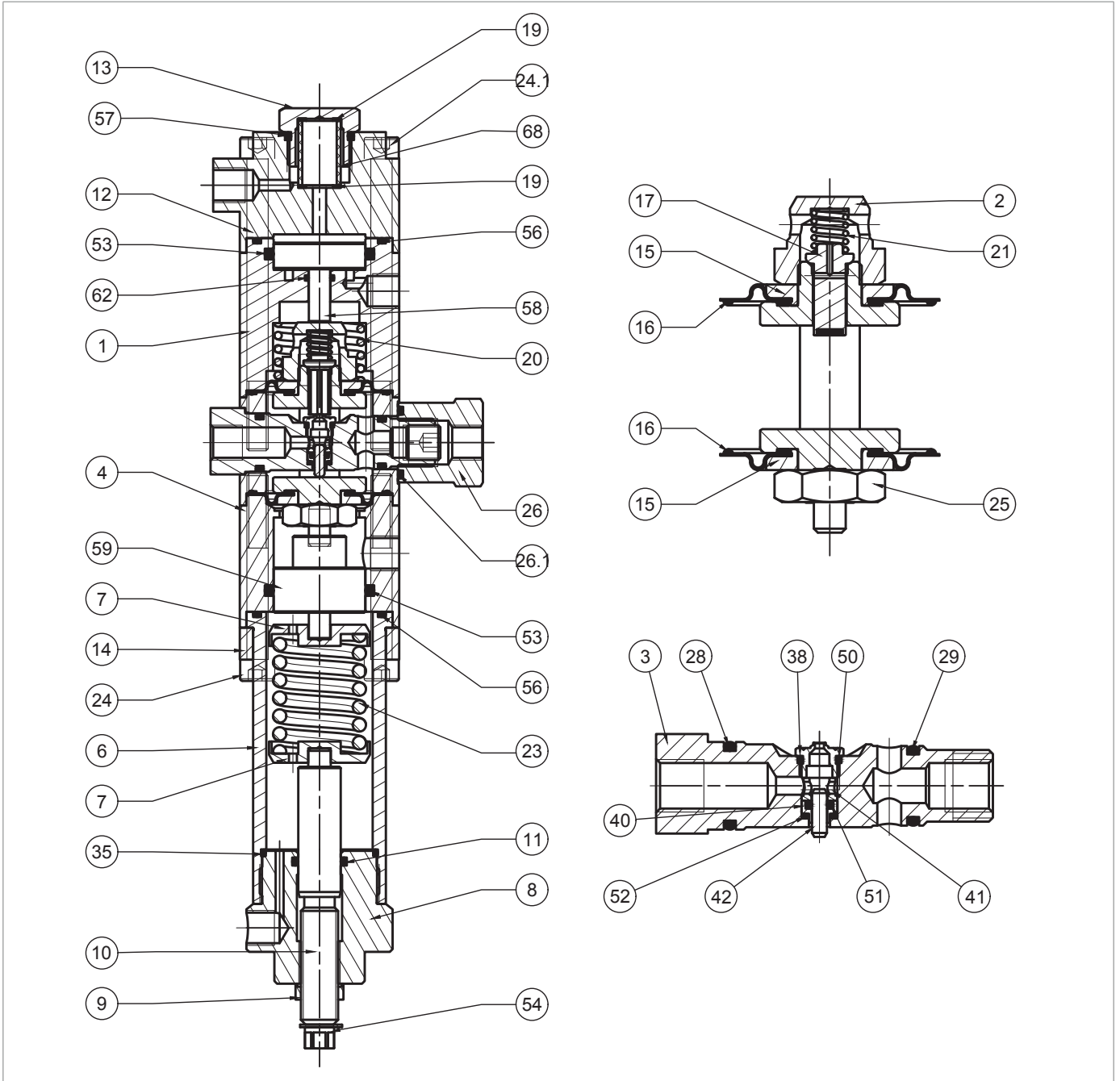









Fig. 9.82. Pressure regulator R44/SS

Step	Action
1	Remove the Seeger ring (54).
2	Unscrew the nut (9).
3	Completely release the spring (23) by turning the adjusting screw (10).
4	Unscrew and remove the cap (8).
5	Remove the spring (23) and the spring supports (7).
6	Remove the screw (10) from the cap (8) clockwise, from the inside outwards.
7	Remove the O-ring (11) from the cap (8) and replace it, lubricating it with synthetic grease. <div style="border: 1px solid black; padding: 2px;"><b>! NOTICE!</b>  <b>Before inserting the replacement O-ring, clean the retaining slots with a cleaning solution.</b></div>
8	Insert the screw (10) into the cap (8) anti-clockwise, from the outside inwards.
9	Insert the nut (9).
10	Fit the Seeger ring (54).
11	Undo the screws (24).
12	Remove the bracket (14).
13	Remove the sleeve (6).
14	Remove the O-ring (56) from the sleeve (6) and replace it, lubricating it with synthetic grease. <div style="border: 1px solid black; padding: 2px;"><b>! NOTICE!</b>  <b>Before inserting the replacement O-ring, clean the retaining slots with a cleaning solution.</b></div>
15	Remove the O-ring (35) from the sleeve (6) and replace it, lubricating it with synthetic grease. <div style="border: 1px solid black; padding: 2px;"><b>! NOTICE!</b>  <b>Before inserting the replacement O-ring, clean the retaining slots with a cleaning solution.</b></div>
16	Remove the spacer (4).
17	Take out the piston (59).
18	Remove the O-ring (53) from the spacer (4) and replace it, lubricating it with synthetic grease. <div style="border: 1px solid black; padding: 2px;"><b>! NOTICE!</b>  <b>Before inserting the replacement O-ring, clean the retaining slots with a cleaning solution.</b></div>
19	Unscrew and remove the cap (13).
20	Remove the O-ring (57) from the cap (13) and replace it, lubricating it with synthetic grease. <div style="border: 1px solid black; padding: 2px;"><b>! NOTICE!</b>  <b>Before inserting the replacement O-ring, clean the retaining slots with a cleaning solution.</b></div>
21	Remove and replace the filter (68).
22	Remove and replace the gaskets (19).
23	Undo and remove the screws (24.1).
24	Remove the cover (12).





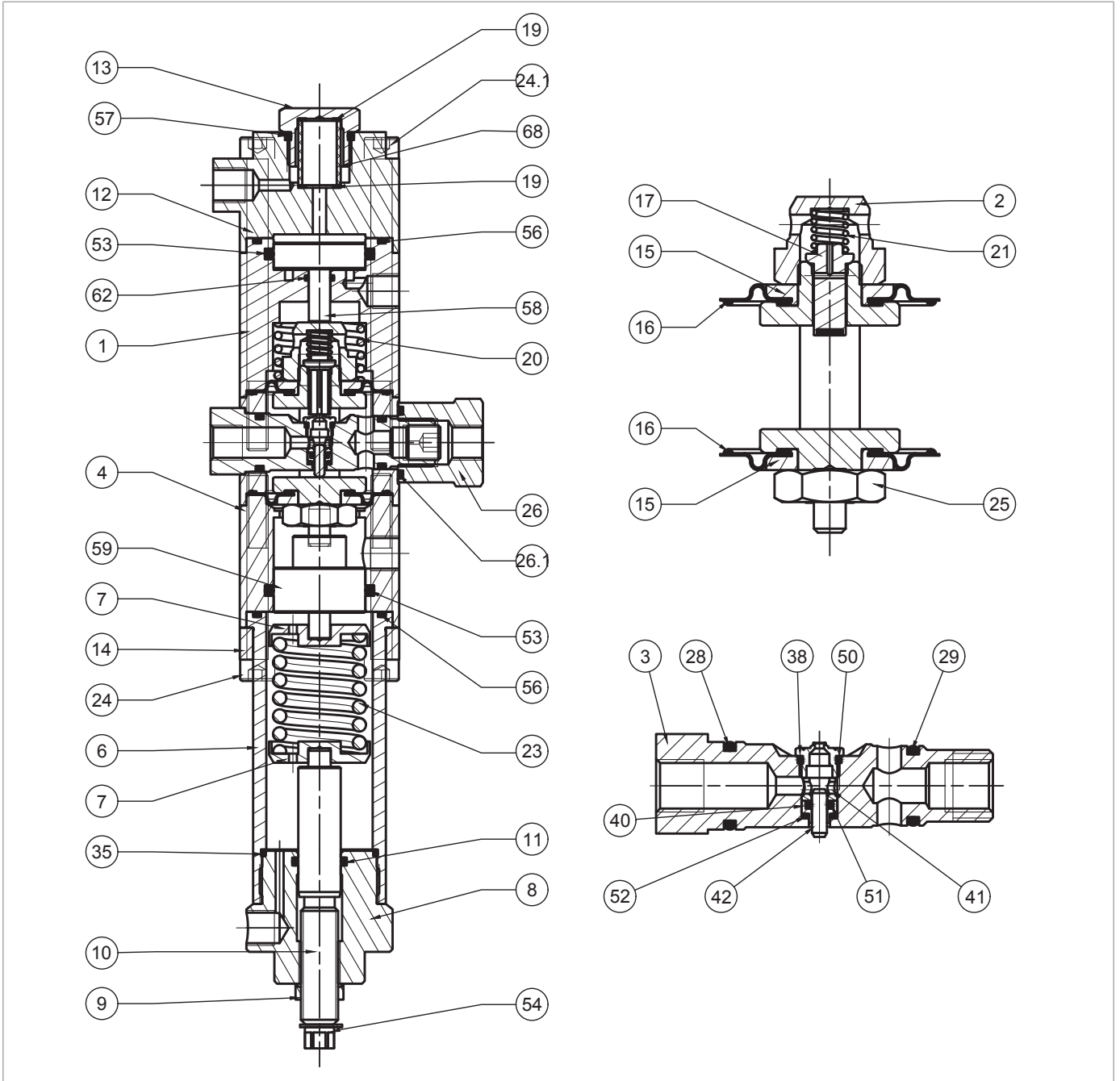

Pressure regulator R44/SS

Step	Action
25	Remove the cover (1).
26	Take out the piston (58).
27	Remove the O-ring (56) from the cover (1) and replace it, lubricating it with synthetic grease. <div style="border: 1px solid black; padding: 2px;">  <b>NOTICE!</b>  <b>Before inserting the replacement O-ring, clean the retaining slots with a cleaning solution.</b> </div>
28	Remove the O-rings (53, 62) from the cover (1) and replace them, lubricating them with synthetic grease. <div style="border: 1px solid black; padding: 2px;">  <b>NOTICE!</b>  <b>Before inserting the replacement O-rings, clean the retaining slots with a cleaning solution.</b> </div>
29	Remove the spring (20).
30	Unscrew the nut (26).
31	Remove the O-ring (26.1) from the nut (26) and replace it, lubricating it with synthetic grease. <div style="border: 1px solid black; padding: 2px;">  <b>NOTICE!</b>  <b>Before inserting the replacement O-ring, clean the retaining slots with a cleaning solution.</b> </div>
32	Pull out the "B" (valve) assembly.
33	Unscrew the valve seat (38). <div style="border: 1px solid black; padding: 2px;">  <b>NOTICE!</b>  <b>Take care not to damage the surfaces.</b> </div>
34	Remove the O-ring (50) from the valve seat (38) and replace it, lubricating it with synthetic grease. <div style="border: 1px solid black; padding: 2px;">  <b>NOTICE!</b>  <b>Before inserting the replacement O-ring, clean the retaining slots with a cleaning solution.</b> </div>
35	Remove the bush (41).
36	Remove the balancing piston (42).
37	Take out the piston guide (40).
38	Remove the O-ring (51) from the piston guide (40) and replace it, lubricating it with synthetic grease. <div style="border: 1px solid black; padding: 2px;">  <b>NOTICE!</b>  <b>Before inserting the replacement O-ring, clean the retaining slots with a cleaning solution.</b> </div>
39	Remove the O-ring (52) from the valve seat (3) and replace it, lubricating it with synthetic grease. <div style="border: 1px solid black; padding: 2px;">  <b>NOTICE!</b>  <b>Before inserting the replacement O-ring, clean the retaining slots with a cleaning solution.</b> </div>





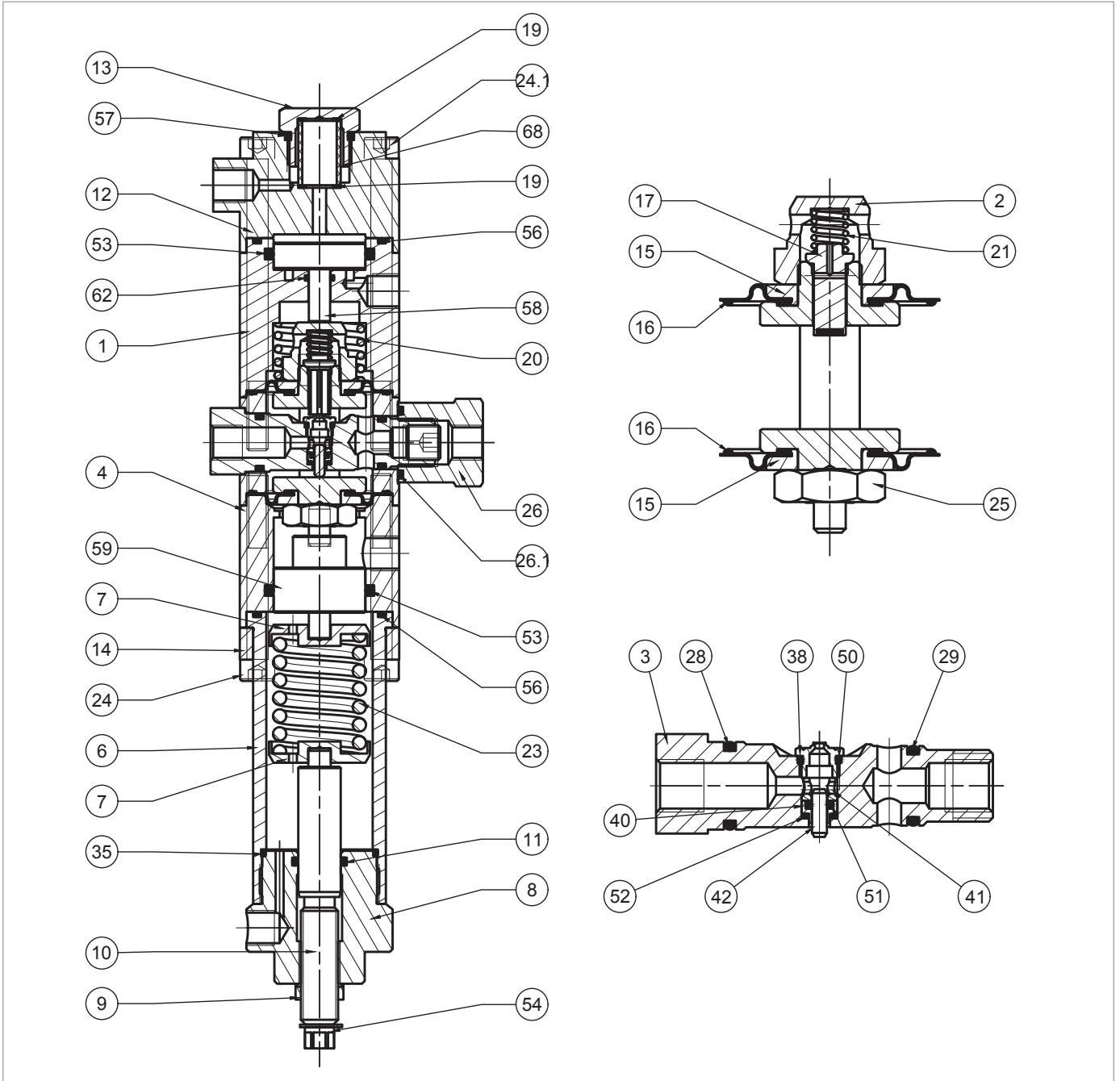

Pressure regulator R44/SS

Step	Action
40	Remove the O-rings (28, 29) from the valve seat (3) and replace them, lubricating them with synthetic grease. <div style="border: 1px solid black; padding: 5px;">  <b>NOTICE!</b>  <b>Before inserting the replacement O-rings, clean the retaining slots with a cleaning solution.</b> </div>
41	Fit the piston guide (40) and balancing piston (42).
42	Insert the bush (41) into the pilot seat (3) so that the wider stop rests on the O-ring (51).
43	Insert and fix the valve seat (38). <div style="border: 1px solid black; padding: 5px;">  <b>NOTICE!</b>  <b>Take care not to damage the valve seat profile (38) and the O-ring (50).</b> </div>
44	Remove assembly "A" (plug) from the valve body (4).
45	Unscrew and remove the pilot nut (2).
46	Remove the spring (21).
47	Remove and replace the plug (17).
48	Remove the upper protection disc (15)
49	Remove and replace the upper diaphragm (16), lubricating the lanyards with synthetic grease. <div style="border: 1px solid black; padding: 5px;">  <b>NOTICE!</b>  <b>Before inserting the replacement diaphragm, clean the retaining slots with a cleaning solution.</b> </div>
50	Unscrew and remove the nut (25).
51	Remove the lower protection disc (15).
52	Remove and replace the lower diaphragm (16), lubricating the lanyards with synthetic grease. <div style="border: 1px solid black; padding: 5px;">  <b>NOTICE!</b>  <b>Before inserting the replacement diaphragm, clean the retaining slots with a cleaning solution.</b> </div>
53	Fit the lower protection disc (15).
54	Insert and fix the screws (25) according to the following tightening torque: <ul style="list-style-type: none"> <li>• R44/SS: Tab. 9.125</li> </ul>
55	Fit the upper protection disc (15).
56	Fit the plug (17).
57	Fit the spring (21).
58	Insert and fix the pilot nut (2) according to the following tightening torque: <ul style="list-style-type: none"> <li>• R44/SS: Tab. 9.125</li> </ul>
59	Insert assembly "A" (plug) from top to bottom into the valve body (4). <div style="border: 1px solid black; padding: 5px;">  <b>NOTICE!</b> <ul style="list-style-type: none"> <li>• <b>Take care not to damage the diaphragms (16) during this step;</b></li> <li>• <b>The marking on the lower section of the headframe (5) must be parallel to the axis of the hole for inserting the seat (3) into the valve body (4).</b></li> </ul> </div>



Pressure regulator R44/SS

Step	Action
60	Insert assembly "B" (valve) into the valve body (4). <div style="border: 1px solid black; padding: 5px;">  <b>NOTICE!</b>  <ul style="list-style-type: none"> <li>• <b>Insert the assembly with the valve seat (38) facing upwards;</b></li> <li>• <b>Take care not to damage the O-rings (28, 29) and the valve seat (38).</b></li> </ul> </div>
61	Screw in the nut (26) as far as it will go.
62	Fit the spring (20).
63	Insert the piston (58) into the cover (1).
64	Fit the covers (1 and 12).
65	Insert and fix the screws (24.1) according to the following tightening torque: <ul style="list-style-type: none"> <li>• R44/SS: Tab. 9.125</li> </ul> <div style="border: 1px solid black; padding: 5px;">  <b>NOTICE!</b>  <b>Tighten the screws as shown in the diagram at "9.4.2.2 - Cross diagram for tightening screws".</b> </div>
66	Fit the gaskets (19) and the filter (68).
67	Fit and secure the nut (13)
68	Fit the piston (59) into the spacer (4).
69	Fit the sleeve (6).
70	Put the bracket (14) back in place.
71	Insert and fix the screws (24) according to the following tightening torque: <ul style="list-style-type: none"> <li>• R44/SS: Tab. 9.125</li> </ul> <div style="border: 1px solid black; padding: 5px;">  <b>NOTICE!</b>  <b>Tighten the screws as shown in the diagram at "9.4.2.2 - Cross diagram for tightening screws".</b> </div>
72	Insert the spring (23) together with the spring supports (7). <div style="border: 1px solid black; padding: 5px;">  <b>NOTICE!</b>  <b>Make sure that the piston pin (59) is inside the spring support (7).</b> </div>
73	Fit and secure the cap (8) to the sleeve (6).

Tab. 9.156

 **WARNING!**

**Ensure that all parts have been fitted correctly.**

9.4.11.5 - SAFETY VALVE VS/FI FOR LINE OFF 2.0

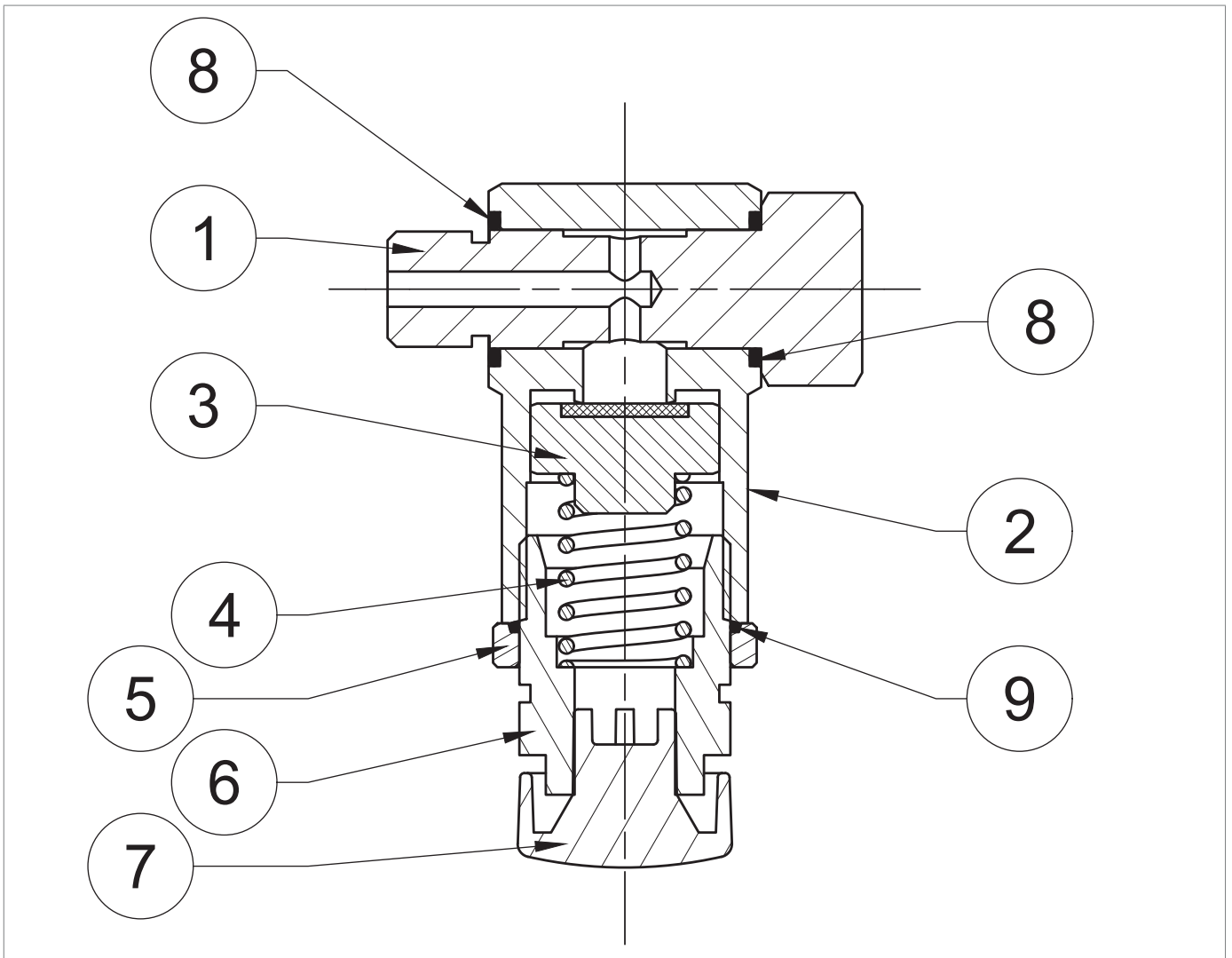

Fig. 9.83. Safety valve VS/FI for LINE OFF 2.0

Step	Action
1	Pull out the locking screw (1).
2	Remove the O-rings (8) from the body (2) and replace them, lubricating them with synthetic grease. <b>NOTICE!</b> <b>Before inserting the replacement O-ring, clean the retaining slots with a cleaning solution.</b>
3	Remove the vent plug (7) and make sure that it is not obstructed by any dirt.
4	Loosen the ring nut (5).
5	Unscrew and remove the cap (6).
6	Remove the O-ring (9) from the ring nut (5) and replace it, lubricating it with synthetic grease. <b>NOTICE!</b> <b>Before inserting the replacement O-ring, clean the retaining slots with a cleaning solution.</b>
7	Remove the spring (4).
8	Remove and replace the plug (3).
9	Insert the plug (3) and the spring (4).
10	Insert and screw in the cap (6).
11	Fit the vent cap (7).
12	Insert the locking screw (1).

Tab. 9.157

**! WARNING!**

**Ensure that all parts have been fitted correctly.**

**9.4.11.6 - PRESSURE SWITCHES MODELS 102 - 105**

**! NOTICE!**

**For more information, please refer to the chapter “9.4.9 - Maintenance procedure for pressure switches Mod. 100”.**

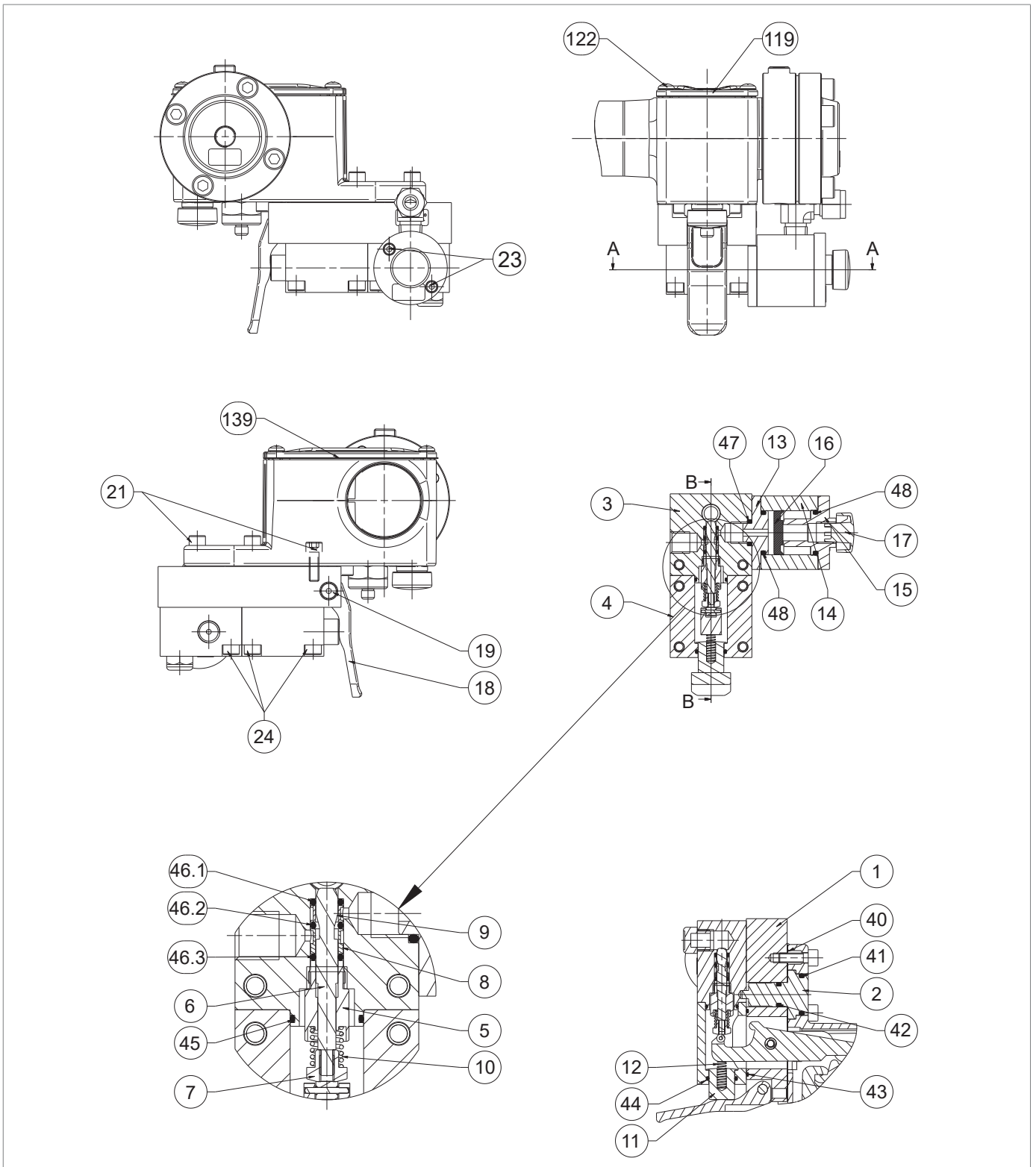







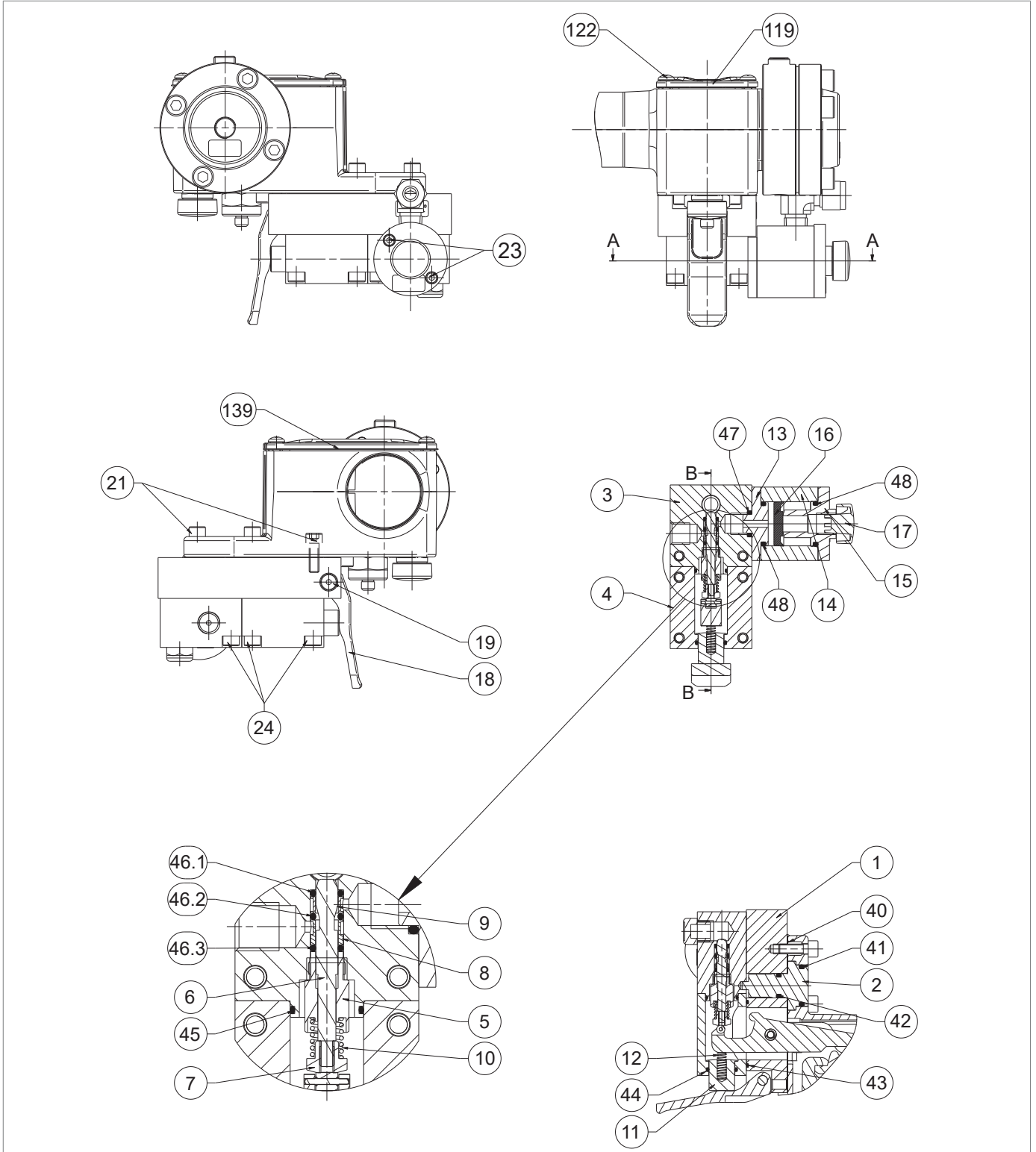

Fig. 9.84. Valve 3/2

Step	Action
1	 <b>NOTICE!</b> <b>Make sure the block is in the OFF state</b>
2	Undo and remove the screws (122) of the pressure switch cover (119).
3	Remove the pressure switch cover (119) together with the gasket (139).
4	Turn the device upside down.
5	Undo and remove the screw (19) and the lever (18).
6	Undo and remove the screws (23).
7	Remove the quick discharge assembly (13, 14, 15, 17).
8	Remove the O-ring (47) from the valve body (3) and lubricate it with synthetic grease.  <b>NOTICE!</b> <b>Before inserting the replacement O-ring, clean the retaining slots with a cleaning solution.</b>
9	Remove the locking flange (15).
10	Remove the O-ring (48) from the shut-off flange (15) and replace it, lubricating it with synthetic grease.  <b>NOTICE!</b> <b>Before inserting the replacement O-ring, clean the retaining slots with a cleaning solution.</b>
11	Remove and replace the gasket (16), lubricating it with synthetic grease.  <b>NOTICE!</b> <b>Orient the lip of the seal (16) towards the cover (15).</b>
12	Remove the intermediate flange (13).
13	Remove the O-ring (48) from the intermediate flange (13) and replace it, lubricating it with synthetic grease.  <b>NOTICE!</b> <b>Before inserting the replacement O-ring, clean the retaining slots with a cleaning solution.</b>
14	Undo and remove the screws (24).
15	Lift the valve body (3) together with the valve cover (4).
16	Separate the valve body (3) from the valve cover (4).
17	Remove the O-ring (45) from the valve cover (3) and lubricate it with synthetic grease.  <b>NOTICE!</b> <b>Before inserting the replacement O-ring, clean the retaining slots with a cleaning solution.</b>
18	Pull out the button (11) together with the spring (12),
19	Remove the O-ring (44) from the valve cover (4) and lubricate it with synthetic grease.  <b>NOTICE!</b> <b>Before inserting the replacement O-ring, clean the retaining slots with a cleaning solution.</b>
20	Fit the button (11) together with the spring (12).
21	Unscrew and remove the stem assembly (5, 6, 7, 8, 9, 10).
22	Remove the O-ring (46.3) and the bush (8).



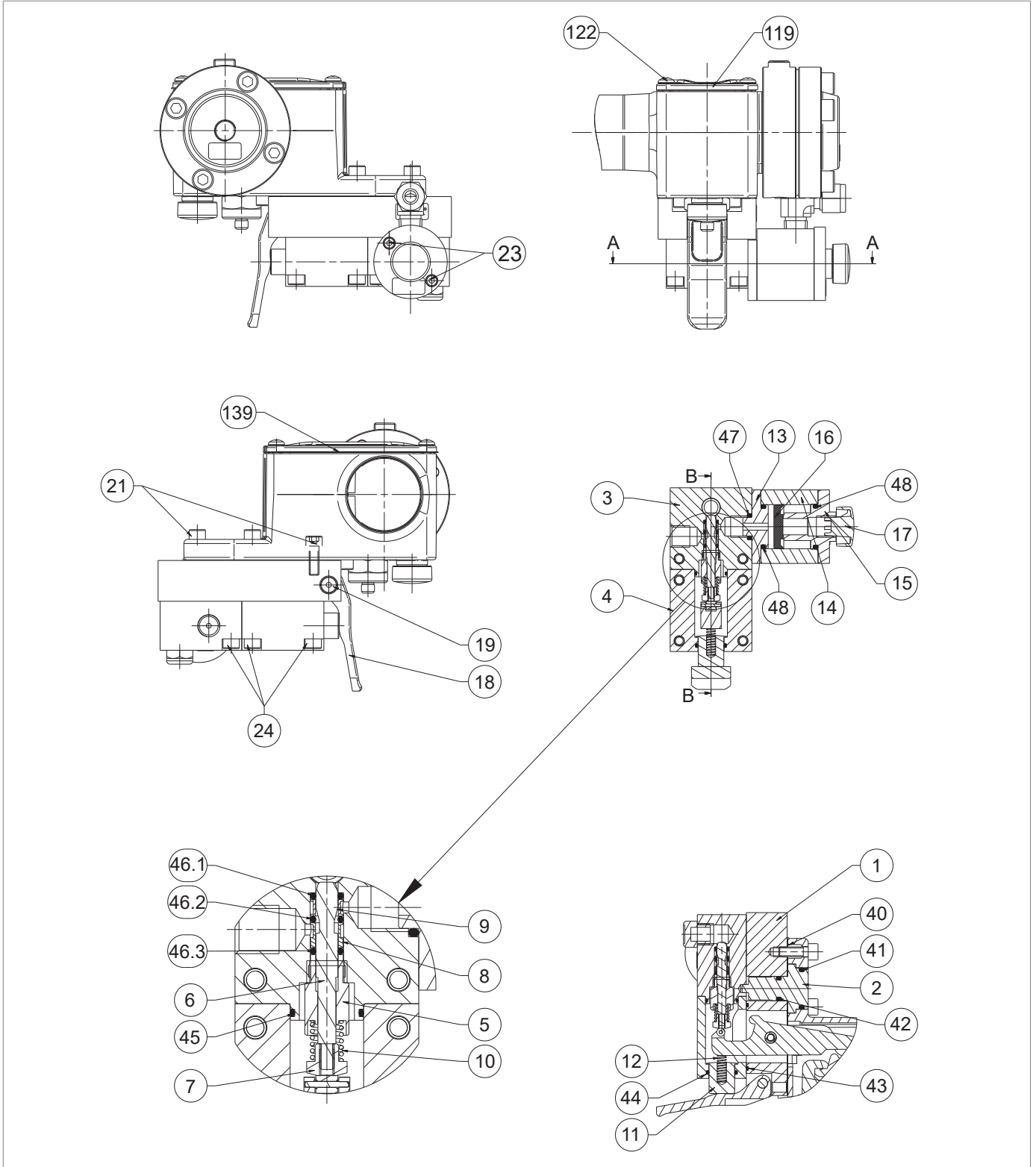

Valve 3/2

Step	Action
23	Remove the O-ring (46.2) and the bush (9).
24	Remove the O-ring (46.1).
25	Replace the O-rings (46.1, 46.2 and 46.3) and lubricate them with synthetic grease. <b>NOTICE!</b> <b>Before inserting the replacement O-rings, clean the retaining slots with a cleaning solution.</b>
26	Insert the O-ring (46.1) and the perforated bushing (9). <b>NOTICE!</b> <b>Use the equipment (P) of "Tab. 7.57".</b>
27	Insert the O-ring (46.2) and the perforated bush (8). <b>NOTICE!</b> <ul style="list-style-type: none"> <li>• Use the equipment (P) of "Tab. 7.57"</li> <li>• Align the bush (8) as shown in detail (C)</li> </ul>
28	Insert the O-ring (46.3). <b>NOTICE!</b> <b>Use the equipment (P) of "Tab. 7.57".</b>
29	Insert and press the equipment (P) together with the O-rings (46.1, 46.2, 46.3) and the perforated bushes (8, 9) into the valve body (3).
30	Remove the equipment (P).
31	Insert and screw the stem assembly (5, 6, 7, 8, 9, 10).
32	Remove the O-ring (43) from the valve bracket (1) and replace it, lubricating it with synthetic grease. <b>NOTICE!</b> <b>Before inserting the replacement O-ring, clean the retaining slots with a cleaning solution.</b>
33	Turn the device upside down.
34	Undo and remove the outer screws (21).
35	Undo and remove the inner screws (21).
36	Lift the pressure switch.
37	Remove the centring pin (2).
38	Remove the O-rings (41, 42) from the centring pin (2) and replace them, lubricating them with synthetic grease. <b>NOTICE!</b> <b>Before inserting the replacement O-rings, clean the retaining slots with a cleaning solution.</b>
39	Remove and replace the gasket (40).
40	Fit the centring pin (2) on the valve bracket (1).
41	Assemble the pressure switch to the valve bracket (1).
42	Insert and fix the screws (21).
43	Insert and fix the internal screws (21).
44	Turn the device upside down.



Valve 3/2

Step	Action
45	Insert the valve cover (4) so that the spring (12) rests on the lever of the pressure switch.  <b>NOTICE!</b> <b>Keep the valve cover (4) tilted for easier assembly.</b>
46	Push and tilt the valve cover upwards (4).
47	Insert the valve body (3) together with the stem assembly (5, 6, 7, 8, 9, 10) into the valve cover (4).  <b>NOTICE!</b> <b>The valve body (3) must be centred with the centring pin (2).</b>
48	Fasten the screws (24) of the valve body (3).
49	Fasten the screws (24) of the valve cover (4).
50	Fit the lever (18).
51	Insert and fix the screws (19).
52	Insert the flange (15) into the cylinder (14).
53	Insert the gasket (16) into the cylinder (14) with the flat side facing upwards.
54	Insert the flange (13) into the cylinder (14).
55	Insert the screws (23).
56	Fit the quick discharge assembly (13, 14, 15, 17) into the valve body (3).
57	Fix the screws (23).
58	Fit the cover (119) together with the gasket (139).
59	Insert and fix the screws (122) of the pressure switch.

Tab. 9.158

 **WARNING!**

**Ensure that all parts have been fitted correctly.**

**9.4.12 - LINE OFF 2.0 MAINTENANCE PROCEDURE**

**9.4.12.1 - LINE OFF 2.0 RECONNECTION**

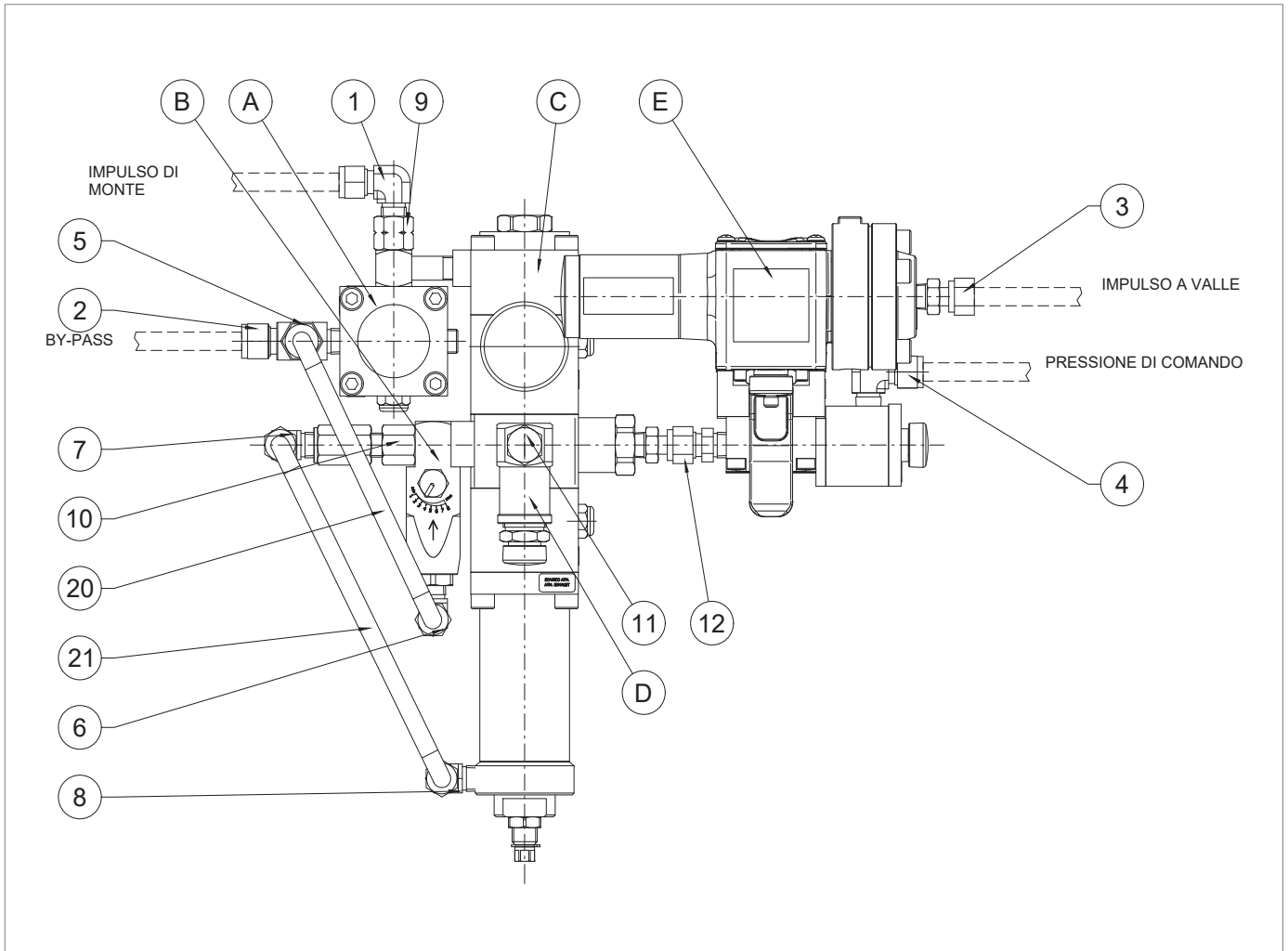

Fig. 9.85. LINE OFF 2.0

To reconnect the LINE OFF 2.0, proceed as indicated at Tab. 9.159:

Step	Action
1	Remove assembly "E" (valve <b>3/2</b> and control device) from assembly "C" (regulator <b>R44/SS</b> ) together with the fitting (12).
2	Remove assembly "D" (safety valve <b>VS/FI</b> ) together with the fitting (11).
3	Remove assembly "B" (throttle valve <b>AR100</b> ) together with the fitting (10).
4	Remove assembly "A" (bypass device <b>HP2/2</b> ) together with the fitting (9).
5	Reconnect the pipe (21) together with the fittings (7, 8).
6	Reconnect the pipe (20) together with the fittings (5, 6).
7	Insert and tighten the fixing screw to put the LINE OFF 2.0 in place.
8	Reconnect the pipes together with the fittings (1, 2, 3, 4).

Tab. 9.159

### 9.4.13 - PROCEDURE FOR RECOMMISSIONING AFTER MAINTENANCE

#### NOTICE!

**For the recommissioning procedure, refer to the relevant paragraph.**

PAGE INTENTIONALLY LEFT BLANK

## 10 - TROUBLESHOOTING

Listed below are the cases (causes and tripping) that could occur in the form of malfunctions of various kinds over time. These situations depend on the conditions of the gas as well as on the natural ageing and wear of the materials.

### 10.1 - GENERAL WARNINGS

#### **HAZARD!**

**Maintenance work must be carried out by qualified personnel:**

- trained in workplace safety also based on the regulations in force in the place of installation of the work equipment;
- qualified and authorised to carry out activities related to the equipment.

#### **WARNING!**







Shall not be held liable for any damage to people and property due to PIETRO FIORENTINI S.p.A. actions:

- other than those described;
- performed according to methods other than those specified;
- carried out by unsuitable personnel.

#### **NOTICE!**

If an operating fault occurs and qualified personnel are not available for the specific intervention, call the Assistance Centre authorised by PIETRO FIORENTINI S.p.A.

## 10.2 - OPERATOR QUALIFICATION SPECIFICATION

Commissioning	
<b>Operator qualification</b>	<ul style="list-style-type: none"> <li>• Mechanical maintenance technician;</li> <li>• Electrical maintenance technician;</li> <li>• Installer;</li> <li>• User technician.</li> </ul>
<b>PPE required</b>	<div style="display: flex; align-items: center; gap: 10px;">      </div> <div style="background-color: #f4a460; padding: 5px; margin-top: 5px;">  <b>WARNING!</b> </div> <p>The PPE listed in this table is related to the risk associated with the equipment. For the required PPE to protect against risks associated with the workplace, installation or operating conditions, please refer to:</p> <ul style="list-style-type: none"> <li>• the regulations in force in the country of installation;</li> <li>• <u>any information provided by the Safety Manager at the installation facility.</u></li> </ul>
<b>Equipment required</b>	Please refer to the chapter “7 - Commissioning/maintenance equipment”.

Tab. 10.160

## 10.3 - TROUBLESHOOTING PROCEDURES

For proper troubleshooting, proceed as follows:

- close the upstream and downstream shut-off valves;
- refer to the troubleshooting tables listed below.

## 10.4 - TROUBLESHOOTING TABLES

**! NOTICE!**

See chapter “9 - Maintenance and functional checks” for pictures of the regulator REFLUX 819/FO and its accessories.

### 10.4.1 - TROUBLESHOOTING REFLUX 819/FO REGULATOR

Failure	Device	Possible causes	Intervention
<b>Anomalies of operation.</b>	REGULATOR	Dirty or worn reinforced gasket (7)	Clean and replace if needed
		O-ring (35) friction	Lubricate and replace if necessary
		Stem guide O-ring (36) frictions	Lubricate and replace if necessary
		I/DWR (52) frictions	Lubricate and replace if necessary
		I/DWR (51) friction	Lubricate and replace if necessary
		Breakage of the diaphragm (50)	Replace
		SG out of class due to dirty or worn reinforced gasket (7)	Clean and replace if needed
	PRE-REGULATOR R14/A/FO	Dirty or worn plug (5)	Clean and replace if needed
		Plug guide ring (8) worn	Replace
	200/A/FO SERIES PILOT	Dirty or worn plug (17)	Clean and replace if needed
		Friction of the diaphragm carrier assembly (16)	Align the support hole diaphragms (5) with the seat valve (3)
		Worn diaphragms (16)	Replace
		Spring (22) collapsed or out of level	Reposition and replace if necessary
AC out of class due to unsuitable spring (22)		Replace	
SG out of class due to dirty or worn plug (17)		Clean and replace if needed	

Failure	Device	Possible causes	Intervention
<b>Failed sealing or zero flow rate</b>	REGULATOR	Reinforced gasket (8) dirty or worn	Clean and replace if needed
		O-ring (35) not sealing	Clean and replace if needed
		Balancing piston O-ring (36) not sealing	Clean and replace if needed
		O-ring (42) not sealing	Clean and replace if needed
		O-ring (43) not sealing	Clean and replace if needed
	PRE-REGULATOR R14/A/FO	O-ring (17) not sealing	Clean and replace if needed
		O-ring (18) not sealing	Clean and replace if needed
		O-ring (20) not sealing	Clean and replace if needed
		Diaphragm (10) damaged	Replace
	200/A/FO SERIES PILOT	Upper diaphragm (19) damaged	Replace
Dirty or worn plug (17)		Clean and replace if needed	
<b>Downstream pressure increases in delivery</b>	REGULATOR	Reinforced gasket (7) damaged	Replace
		Ice between reinforced gasket (7) and plug (5)	Increase the gas inlet temperature of the regulator
		Soiling between reinforced gasket (7) and plug (5)	Clean and check gas filtration
		Plug (5) locked	Clean and check the movements
		Tightening screws (29) of the diaphragm assembly (50)	Tighten properly
		Transfer hole (21) obstructed	Clean
		Plug guide O-ring (35) damaged	Replace
		Stem guide O-ring (36) frictions	Lubricate and replace if necessary
		I/DWR (52) frictions	Lubricate and replace if necessary
		I/DWR (51) friction	Lubricate and replace if necessary
		Spring (54) collapsed	Replace
		PRE-REGULATOR R14/A/FO	Plug (5) damaged
	200/A SERIES PILOTS	Plug (17) damaged	Replace
		Diaphragm holder (16) and plug (17) assembly locked in open position	Check and clean if necessary
		Plug spring (21) collapsed	Replace
		Downstream sensing line obstructed	Clean

Failure	Device	Possible causes	Intervention
<b>Downstream pressure decreases in delivery</b>	REGULATOR	No upstream pressure	Check line filter cartridges for clogging
		Plug (5) locked	Clean and check the movements
		Dirty O-ring (35)	Clean and replace if needed
		Stem guide (20) O-ring frictions (36)	Lubricate and replace if necessary
		I/DWR (52) frictions	Lubricate and replace if necessary
		I/DWR (51) friction	Lubricate and replace if necessary
		Ice formation	Increase the gas inlet temperature of the regulator
		Diaphragm (50) damaged	Replace
		Stem guide (20) loose	Tighten
	PRE-REGULATOR R14/A/FO	Filter (13) clogged	Replace
		Reinforced gasket (9) damaged	Replace
		Diaphragm (10) damaged	Replace
		Plug (5) locked in in closing	Clean and lubricate
		Plug (5) obstructed	Clean
	200/A/FO SERIES PI- LOTS	Plug (17) locked in shut-off position	Clean and lubricate
		Diaphragms (16) damaged	Replace
		Diaphragm holder (16) and plug (17) assembly locked in open position	Check and clean if necessary
		Valve seat (3) clogged	Clean
Spring (22) collapsed		Replace	

Tab. 10.161.

#### 10.4.2 - DB/819 SILENCER TROUBLESHOOTING

Failure	Device	Possible causes	Intervention
<b>Increase in noise</b>	DB/819 SILENCER	Breakage of the external basket (64)	Replace
<b>Failed sealing Zero flow rate</b>	DB/819 SILENCER	Failed sealing of the O-ring (39)	Clean and replace if needed
		Failed sealing of the O-ring (84)	Clean and replace if needed

Tab. 10.162

### 10.4.3 - APM/819 BUILT-IN MONITOR TROUBLESHOOTING

Failure	Device	Possible causes	Intervention
<b>Abnormalities of operation</b>	PRE-REGULATOR R14/A	Dirty or worn plug (9)	Clean and replace if needed
		Guide ring (8) worn	Replace
	200/A SERIES PILOTS	Dirty or worn plug (17)	Clean and replace if needed
		Diaphragm holders unit friction (16)	Centre the hole, assembly and shaft movement
		Worn diaphragms (16)	Replace
		Spring (22) collapsed or out of level	Refit and replace if needed
		AC out of class due to unsuitable spring (22)	Replace
		SG out of class due to dirty or worn plug (17)	Clean and replace if needed
	REGULATOR	Reinforced gasket dirty or worn	Clean and replace if needed
		O-ring (35) friction	Lubricate and if needed replace
		Stem guide O-ring (36) frictions	Lubricate and if needed replace
		I/DWR (52) frictions	Lubricate and if needed replace
		I/DWR (51) friction	Lubricate and if needed replace
		Breakage of the diaphragm (50)	Replace
SG out of class due to dirty or worn reinforced gasket		Clean and replace if needed	

Failure	Device	Possible causes	Intervention
<b>Failed sealing Zero flow rate</b>	PRE-REGULATOR R14/A	Failed sealing of the O-ring (17)	Clean and replace if needed
		Failed sealing of the O-ring (18)	Clean and replace if needed
		Failed sealing of the O-ring (20)	Clean and replace if needed
		Diaphragm (10) worn	Replace
	200/A SERIES PILOTS	Diaphragm (16 upper) worn	Replace
		Dirty or worn plug (17)	Clean and replace if needed
	REGULATOR	Reinforced gasket (8) dirty or worn	Clean and replace if needed
		Failed sealing of the O-ring (35)	Clean and replace if needed
		Failed sealing of the O-ring (36) of the balancing piston	Clean and replace if needed
		Failed sealing of the O-ring (42)	Clean and replace if needed
		Failed sealing of the O-ring (43)	Clean and replace if needed
	<b>Downstream pressure increases</b>	PRE-REGULATOR R14/A	Plug (9) damaged
200/A SERIES PILOTS		Plug (17) damaged	Replace
		Diaphragm holder (16) and plug (17) assembly locked in open position	Check and clean if needed
		Plug spring collapsed	Replace
		Downstream sensing line obstructed	Clean
REGULATOR		Reinforced gasket (8) damaged	Replace
		Ice between reinforced gasket (8) and plug (71)	Increase the gas inlet temperature of the regulator
		Soiling between reinforced gasket (8) and plug (71)	Clean and check gas filtration
		Plug (71) locked	Clean and check the movements
		Imperfect control-element unit tightening	Tighten properly
		Transfer hole clogged	Clean
		Plug guide O-ring (35) damaged	Replace
		Stem guide O-ring (36) frictions	Lubricate and if needed replace
		I/DWR (52) frictions	Lubricate and if needed replace
		I/DWR (51) friction	Lubricate and if needed replace
Spring (80) collapsed	Replace		

Failure	Device	Possible causes	Intervention
<b>Downstream pressure decreases</b>	PRE-REGULATOR R14/A	Filter clogging (13)	Replace
		Plug (9) deformation	Replace
		Diaphragm (10) damaged	Replace
		Blocked stem (203) in closing	Clean and lubricate
		Stem (5) clogged	Clean
	200/A SERIES PILOTS	Plug (17) locked in shut-off position	Clean and lubricate
		Diaphragms (16) damaged	Replace
		Diaphragm holder (16) and plug (17) assembly locked in open position	Check and clean if needed
		Valve seat (3) clogged	Clean
		Spring (22) collapsed	Replace
	PM 819 MONITOR	No upstream pressure	Check line filter cartridges for clogging
		Plug (71) locked	Clean and check the movements
		Dirty O-ring (35)	Clean and replace if needed
		Stem guide O-Ring (36) frictions	Lubricate and if needed replace
		I/DWR (52) frictions	Lubricate and if needed replace
		I/DWR (51) friction	Lubricate and if needed replace
		Ice formation	Increase gas inlet temperature regulator
Diaphragm (50) damaged		Replace	
Nut (11) loosened	Tighten		

Tab. 10.163

#### 10.4.4 - SB/82 BUILT-IN SLAM-SHUT VALVE TROUBLESHOOTING

 **WARNING!**

If the built-in slam-shut valve tripped, close the inlet and outlet valves (V1 and V2) of the line before any other operation and discharge pressure.

Failure	Device	Possible causes	Intervention
<b>Incorrect release pressure</b>	SLAM-SHUT VALVE SB/82 BUILT-IN SLAM-SHUT VALVE	Incorrect spring calibration of max. and/or min.	Repeat calibration by adjusting the ring nuts. If the minimum setting is also required, recalibrate the maximum and minimum springs several times in this sequence
		Lever mechanisms with friction	Clean and lubricate the levers and if needed replace the pressure switch
	PRESSURE SWITCHES MODELS 102 ÷ 105	Springs (11.17) collapsed	Replace
		Springs (11.17) out of level	Refit
<b>Impossible to reset</b>	SLAM-SHUT VALVE SB/82 BUILT-IN SLAM-SHUT VALVE	Max. and/or min. pressure spring incorrect calibration.	Repeat calibration by adjusting the ring nuts
		The downstream pressure is not consistent with the min and/or max setting of the slam-shut device	Adjust the downstream pressure
		Levers broken or chipped	Changing the standard box containing the entire complex
	PRESSURE SWITCHES MODELS 102 ÷ 105	Membrane rupture (43) if min. spring is present.	Replace
Release button manual locked		Clean and lubricate. Check that the reset pressure is consistent with the pressure switch settings	
<b>Failure to provide service</b>	SLAM-SHUT VALVE SB/82 BUILT-IN SLAM-SHUT VALVE	Blocked stem (6) in opening	Clean and lubricate
		Locked lever mechanisms	Clean and lubricate
	PRESSURE SWITCHES MODELS 102 ÷ 105	Membrane rupture (43) if min. spring is missing.	Replace

Failure	Device	Possible causes	Intervention
<b>Downstream pressure increase with slam-shut device shutting off</b>	SLAM-SHUT VALVE SB/82 BUILT-IN SLAM-SHUT VALVE DN 1" - 3"	Failed sealing of the O-ring (40)	Clean and replace if needed
		Plug pad (19) not sealing	Clean and replace if needed
		Conical seat (8) damaged	Replace
		Failed sealing of the O-ring (39)	Clean and replace if needed
	SLAM-SHUT VALVE SB/82 BUILT-IN SLAM-SHUT VALVE DN 4" - 8"	Failed sealing of the O-ring (40)	Clean and replace if needed
		Plug pad (19) not sealing	Clean and replace if needed
		Failed sealing of the O-ring (44)	Clean and replace if needed
		Conical seat (8) damaged	Replace
	SLAM-SHUT VALVE SB/82 BUILT-IN SLAM-SHUT VALVE DN 10"	Failed sealing of the O-ring (39)	Clean and replace if needed
		Reinforced gasket (8) not sealing	Clean and replace if needed
		Failed sealing of the O-ring (42)	Clean and replace if needed
		Valve seat (2) damaged	Replace
	BYPASS DEVICE HP2/2	Failed sealing of the pad O-ring (5)	Clean and replace if needed
		Failed sealing of the O-ring (15)	Clean and replace if needed
		Valve seat (6) damaged	Replace
		Failed sealing of the O-ring (20)	Clean and replace if needed

*Tab. 10.164*

## 10.4.5 - HB/97 BUILT-IN SLAM-SHUT VALVE TROUBLESHOOTING

### WARNING!

If the built-in slam-shut valve tripped, close the inlet and outlet valves (V1 and V2) of the line before any other operation and discharge pressure.

Failure	Device	Possible causes	Intervention
<b>Incorrect release pressure</b>	PRESSURE SWITCHES MODELS 102 ÷ 105	Max. and/or min. pressure spring incorrect calibration.	Repeat calibration by adjusting the ring nuts
		Lever mechanisms with friction	Clean and lubricate the lever mechanisms and if necessary replace the box
		Springs (11.17) collapsed	Replace
		Springs (11.17) out of level	Refit
<b>Impossible to reset</b>	SLAM-SHUT VALVE HB/97 BUILT-IN SLAM-SHUT VALVE	Stem (6) locked due to friction	Clean and lubricate
		Stem (6) locked in shut-off position	Clean and lubricate
		Plug (71) locked due to friction	Clean and lubricate
		U-ring (63) damaged	Replace
		I/DWR ring (64) damaged	Replace
	PRESSURE SWITCHES MODELS 102 ÷ 105	Wrong calibration spring of max and / or min.	Repeat calibration by adjusting the ring nuts
		The downstream pressure is not consistent with the min and/or max setting of the slam-shut device	Adjust the downstream pressure
		Lever mechanisms with friction	Clean and lubricate the lever mechanisms and if needed replace the box
		Breakage of the Diaphragm breakage (43) if a min. pressure spring is installed.	Replace
		Release button manual locked	Clean and lubricate
BYPASS DEVICE HP2/2	Filter (11) clogged	Replace	

Failure	Device	Possible causes	Intervention
<b>Delayed shut-off</b>	LAMINATION VALVE AR100	Filter (5) clogged	Replace
	PRESSURE REGULATOR R44/SS	Lower diaphragm (16) breakage	Replace
		Upper diaphragm (16) breakage	Replace
		Failed sealing of the upper O-ring (53)	Clean and replace if needed
		Failed sealing of the lower O-ring (53)	Clean and replace if needed
		Failed sealing of the O-ring (11)	Clean and replace if needed
		Failed sealing of the O-ring (35)	Clean and replace if needed
		Balancing piston (42) locked	Clean and lubricate
		Failed sealing of the O-ring (62)	Clean and replace if needed
	SAFETY VALVE VS/FI	Failed sealing	Check and clean if necessary
	VALVE 3/2	Outer O-rings (46) not sealing	Clean and replace if needed
		Failed sealing of the O-ring (47)	Clean and replace if needed
		Failed sealing of the O-ring (48)	Clean and replace if needed
		Pad (16) dirty or damaged	Clean and replace if needed
	SLAM-SHUT VALVE HB/97 BUILT-INSLAM- SHUT VALVE	Stem (6) with friction	Clean and lubricate
Plug (71) with friction		Clean and lubricate	
VALVE 3/2	Failed sealing of the balancing piston O-ring (36)	Clean and replace if needed	
	Gasket (16) locked	Clean and replace if needed	
	Clogged vents	Check and clean if necessary	

Failure	Device	Possible causes	Intervention
<b>Failure to provide service</b>	SLAM-SHUT VALVE HB/97 BUILT-IN SLAM- SHUT VALVE	Stem (6) locked in opening position	Clean and lubricate
		Plug (71) locked in opening position	Clean and lubricate
		O-ring (36) not sealing	Clean and replace if needed
		I/DWR ring (64) damaged	replace
	PRESSURE SWITCHES MODELS 102 ÷ 105	Breaking Diaphragm rupture (43) if there is no min. spring.	Replace
		Locked lever mechanisms	Check and if necessary clean and lubricate
	VALVE 3/2	Pin (6) locked	Check and if necessary clean and lubricate
		Lip pad (16) locked	Clean and replace if needed
		Clogged vents	Check and clean if needed

Failure	Device	Possible causes	Intervention
<b>Unintentional intervention</b>	SLAM-SHUT VALVE HB/97 BUILT-INSLAM-SHUT VALVE	Failed sealing of the O-ring (40)	Clean and replace if needed
		Failed sealing of the lower O-ring (36)	Clean and replace if needed
		Failed sealing of the O-ring (39)	Clean and replace if needed
		Failed sealing of the U-ring (63)	Clean and replace if needed
		Failed sealing of the O-ring (43)	Clean and replace if needed
		Failed sealing of the upper O-ring (62)	Clean and replace if needed
		Failed sealing of the O-ring (42)	Clean and replace if needed
	PRESSURE REGULATOR R44/SS	Lower diaphragm (16) not sealing	Clean and replace if needed
		Failed sealing of the O-ring (28)	Clean and replace if needed
		Failed sealing of the O-ring (29)	Clean and replace if needed
		Failed sealing of the O-ring (26.1)	Clean and replace if needed
	SAFETY VALVE VS/FI	Lack of Pad seal (3)	Clean and replace if needed
	VALVE 3/2	Gasket (16) locked	Clean and replace if needed
		Outer O-rings (46) not sealing	Clean and replace if needed
Failed sealing of the O-ring (47)		Clean and replace if needed	
Failed sealing of the O-ring (48)		Clean and replace if needed	
<b>Downstream pressure increase with slam-shut device shutting off</b>	SLAM-SHUT VALVE HB/97 BUILT-INSLAM-SHUT VALVE	Reinforced gasket (8) dirty or damaged	Clean and replace if needed
		Failed sealing of the O-ring (39)	Clean and replace if needed
		Plug profile (71) damaged	Replace
		Failed sealing of the O-ring (88)	Clean and replace if needed
		Failed sealing of the O-ring (87)	Clean and replace if needed
	BYPASS DEVICE HP2/2	Failed sealing of the O-ring (21)	Clean and replace if needed
		Damaged seat profile (6)	Replace
		Pad (12) dirty or damaged	Clean and replace if needed
		Failed sealing of the O-ring (24)	Clean and replace if needed

Tab. 10.165

PAGE INTENTIONALLY LEFT BLANK

## 11 - UNINSTALLATION AND DISPOSAL

### 11.1 - GENERAL SAFETY WARNINGS

#### HAZARD!



Make sure that there are no ignition sources in the work area set up to uninstall and/or dispose of the equipment.

#### WARNING!

Before proceeding with uninstallation and disposal, make the equipment safe by disconnecting it from any power supply.

### 11.2 - QUALIFICATION OF THE OPERATORS IN CHARGE

#### Commissioning

Operator qualification	Installer
PPE required	 <p> <b>WARNING!</b></p> <p>The PPE listed in this table is related to the risk associated with the equipment. For the required PPE to protect against risks associated with the workplace, installation or operating conditions, please refer to:</p> <ul style="list-style-type: none"> <li>• the regulations in force in the country of installation;</li> <li>• any information provided by the Safety Manager at the installation facility.</li> </ul>
Equipment required	Please refer to the chapter "7 - Commissioning/maintenance equipment".

Tab. 11.166

### 11.3 - UNINSTALLATION

#### WARNING!

Before any intervention, it is necessary:

- to ensure that the line on which the equipment is installed is shut off upstream and downstream;
  - to operate the slam shut valve in manual mode by pressing the release button (Pos. 10 - Figure 4.13.).
- Next, check that the pressure indicated by the pressure gauge installed on the LINE OFF 2.0 device (Pos. 9.3 - Figure 8.36.) is 0 bar, ensuring complete depressurisation of the line.

#### NOTICE!

For equipment uninstallation procedures, please refer to the installation procedures (see chapter "6 - installation"), proceeding in reverse order.

## 11.4 - INFORMATION REQUIRED IN CASE OF RE-INSTALLATION

### NOTICE!

Should the equipment be reused after uninstallation, please refer to Chapter:

- “6 - installation”;
- “8 - Commissioning”.

## 11.5 - DISPOSAL INFORMATION

### NOTICE!

**Bear in mind that the laws in force in the country where the system is installed must be complied with. Illegal or incorrect disposal involves the application of the penalties provided for by the regulations in force in the country of installation.**

### NOTICE!

**Proper disposal prevents damage to man and the environment and promotes the reuse of precious raw materials.**

The equipment was manufactured with materials that can be recycled by specialised companies. To dispose of the equipment correctly, proceed as indicated in “Tab. 11.167”:

Step	Action
1	Set up a large work area free from obstacles where to safely dismantle the equipment.
2	Sort the various components by type of material for easier recycling through separate collection.
3	Send the materials obtained in <b>Step 2</b> to a specialised company.

Tab. 11.167

The equipment in any possible configuration consists of the following materials:

Material	Disposal/recycling indications
<b>Plastic</b>	It must be dismantled and disposed of separately.
<b>Lubricants/Oils</b>	They must be collected and delivered to the appropriate specialized and authorized collection and disposal centres.
<b>Iron</b>	Disassemble and collect separately. It must be recycled through the specific collection centres.
<b>Steel</b>	Disassemble and collect separately. It must be recycled through the specific collection centres.
<b>Aluminium</b>	Disassemble and collect separately. It must be recycled through the specific collection centres.
<b>Pneumatic/electric components</b>	They must be dismantled in order to be reused if they are still in good condition or, if possible, overhauled and recycled.

Tab. 11.168

### NOTICE!

**Please refer to the chapter “9 - Maintenance and functional checks” to better identify the composition of the equipment and its parts.**

## 12 - RECOMMENDED SPARE PARTS

### 12.1 - GENERAL WARNINGS

#### NOTICE!

If spare parts not marked are used, PIETRO FIORENTINI S.p.A. their declared performance cannot be guaranteed.

It is recommended to use original spare parts PIETRO FIORENTINI S.p.A.

PIETRO FIORENTINI S.p.A. shall not be held liable for any damage caused by using non-original parts..

### 12.2 - HOW TO REQUEST SPARE PARTS

#### NOTICE!

For specific information, please refer to the sales network of PIETRO FIORENTINI S.p.A.

PAGE INTENTIONALLY LEFT BLANK

## 13 - CALIBRATION TABLES

### 13.1 - CALIBRATION TABLES FOR 200/A/FO AND 200/A SERIES PILOTS AND R14/A/FO AND R14/A PRE-REGULATORS

The REFLUX 819/FO regulator uses the 200/A/FO series pilots and the R14/A/FO pre-regulator.

The PM/819 monitor uses the 200/A series of pilots and the R14/A pre-regulator.

The adjustment ranges of the different pilots are shown in the following tables:

Pilot 204/A/FO							
Pos.	Spring item code	Spring colour	d	Lo	De	Min.	Max
1	2701541	White	4	100	35	1	2,2
2	2701800	Yellow	4.5			2,201	3,5
3	2702080	Orange	5			3,501	5
4	2702290	Red	5.5			5,001	8
5	2702460	Green	6			8,001	13
6	2702660	Black	6.5			13.001	20
7	2702820	Blue	7			20,001	33

**d** = Wire Diameter (mm)    **Lo** = Spring Length (mm)    **De** = External Diameter (mm)

Tab. 13.169

Pilot 205/A/FO							
Pos.	Spring item code	Spring colour	d	Lo	De	Min.	Max
1	2702820	Blue	7	100	35	20	30
2	2703045	Brown	7,5			30.001	44
3	2703224	Grey	8			44.001	60

**d** = Wire Diameter (mm)    **Lo** = Spring Length (mm)    **De** = External Diameter (mm)

Tab. 13.170

Pilot 207/A/FO							
Pos.	Spring item code	Spring colour	d	Lo	De	Min.	Max
1	2703224	Grey	8	100	35	41	74

**d** = Wire Diameter (mm)    **Lo** = Spring Length (mm)    **De** = External Diameter (mm)

Tab. 13.171

R14/A/FO Pre-regulator							
Pos.	Spring item code	Spring colour	d	Lo	De	Min.	Max
1	2700629	Yellow	2,2	40	22	1.1	1.1
2	2700645	Red	2.3			1.4	1.4
3	2700648	Sky blue	2.3			1,7	1,7
4	2700775	Green	22.5			2	2

**d** = Wire Diameter (mm)    **Lo** = Spring Length (mm)    **De** = External Diameter (mm)

Tab. 13.172

Pilot 204/A							
Pos.	Spring item code	Spring colour	d	Lo	De	Min.	Max
1	2701260	White	3,5	60	35	0.3	1
2	2701530	Yellow	4			1,001	2
3	2702070	Orange	5			2.001	6
4	2702450	Red	6			6,001	12
5	2702815	Green	7			12.001	18
6	2703220	Black	8			18.001	28
7	2703420	Blue	8,5			28.001	43

**d** = Wire Diameter (mm)    **Lo** = Spring Length (mm)    **De** = External Diameter (mm)

Tab. 13.173

Pilot 205/A							
Pos.	Spring item code	Spring colour	d	Lo	De	Min.	Max
1	2702820	Blue	7	100	35	20	30
2	2703045	Brown	7,5			30.001	44
3	2703224	Grey	8			44.001	60

**d** = Wire Diameter (mm)    **Lo** = Spring Length (mm)    **De** = External Diameter (mm)

Tab. 13.174

Pilot 207/A							
Pos.	Spring item code	Spring colour	d	Lo	De	Min.	Max
1	2703224	Grey	8	100	35	41	74

**d** = Wire Diameter (mm)    **Lo** = Spring Length (mm)    **De** = External Diameter (mm)

Tab. 13.175

Pre-regulator R14/A							
Pos.	Spring item code	Spring colour	d	Lo	De	Min.	Max
1	2700525	Orange	2	40	22	0,65	2,15
2	2700645	Red	2.3			1,25	2.8
3	2700775	Green	2.3			1.95	3,6

**d** = Wire Diameter (mm)    **Lo** = Spring Length (mm)    **De** = External Diameter (mm)

Tab. 13.176

### 13.2 - CALIBRATION TABLES FOR PRESSURE SWITCHES MOD. 100

Below are the calibration tables for the pressure switches that may be installed in the built-in slam-shut valves:

Mod. 102M/102MH - Max pressure							
Pos.	Spring item code	Spring colour	d	Lo	De	Min.	Max
1	2701260	White	3,5	60	35	0,2	0.8
2	2701530	Yellow	4			0.801	1,6
3	2701790	Yellow/black	4.5			1,601	2.6
4	2702280	White/red	5.5			2,601	5.5
<b>d = Wire Diameter (mm)   Lo = Spring Length (mm)   De = External Diameter (mm)</b>							

Tab. 13.177

Mod. 102M - Min pressure							
Pos.	Spring item code	Spring colour	d	Lo	De	Min.	Max
1	2700513	Red	2	40	15	0,05	0,199
2	2700713	Green	2.3			0,2	0,4
3	2700750	Black	2.5			0.401	0.8
4	2700985	Brown	3			0.801	2.8
<b>d = Wire Diameter (mm)   Lo = Spring Length (mm)   De = External Diameter (mm)</b>							

Tab. 13.178

Mod. 102MH - Min pressure							
Pos.	Spring item code	Spring colour	d	Lo	De	Min.	Max
1	2700985	Brown	3	40	15	2.8	4,2
	2700980	Blue	3	35			
2	2700985	Brown	3	40		4,201	5.5
	2700985	Brown	3				
<b>d = Wire Diameter (mm)   Lo = Spring Length (mm)   De = External Diameter (mm)</b>							

Tab. 13.179

Mod. 103M/103MH - Max pressure							
Pos.	Spring item code	Spring colour	d	Lo	De	Min.	Max
1	2701530	Yellow	4	60	35	2	4
2	2701790	Yellow/black	4.5	60		4.001	7,5
3	2702280	White/red	5.5	60		7.501	15
4	2702450	Red	6	60		15.001	22
<b>d = Wire Diameter (mm)   Lo = Spring Length (mm)   De = External Diameter (mm)</b>							

Tab. 13.180

**Mod. 103M - Min pressure**

Pos.	Spring item code	Spring colour	d	Lo	De	Min.	Max
1	2700464	Orange	1,7	40	15	0,2	0,5
2	2700513	Red	2			0,501	0,8
3	2700713	Green	2,3			0,801	1,7
4	2700750	Black	2,5			1,701	4
5	2700985	Brown	3			4,001	8

**d** = Wire Diameter (mm)    **Lo** = Spring Length (mm)    **De** = External Diameter (mm)

*Tab. 13.181*
**Mod. 103MH - Min pressure**

Pos.	Spring item code	Spring colour	d	Lo	De	Min.	Max
1	2700985	Brown	3	40	15	8	13
	2700980	Blue	3	35			
2	2700985	Brown	3	40	15	13,001	19
	2700985	Brown	3				

**d** = Wire Diameter (mm)    **Lo** = Spring Length (mm)    **De** = External Diameter (mm)

**Mod. 104M/104MH - Max pressure**

Pos.	Spring item code	Spring colour	d	Lo	De	Min.	Max
1	2702280	White/Red	5,5	60	35	15,001	30
2	2702450	Red	6	60		30,001	45

**d** = Wire Diameter (mm)    **Lo** = Spring Length (mm)    **De** = External Diameter (mm)

*Tab. 13.182*
**Mod. 104M - Min pressure**

Pos.	Spring item code	Spring colour	d	Lo	De	Min.	Max
1	2700713	Green	2,3	40	15	1,6	3
2	2700750	Black	2,5			3,001	8
3	2700985	Brown	3			8,001	18

**d** = Wire Diameter (mm)    **Lo** = Spring Length (mm)    **De** = External Diameter (mm)

*Tab. 13.183*

Mod. 104MH - Min pressure							
Pos.	Spring item code	Spring colour	d	Lo	De	Min.	Max
1	2700985	Brown	3	40	15	18	30
	2700980	Blue	3	35			
2	2700985	Brown	3	40		30.001	41
	2700985	Brown	3				

**d** = Wire Diameter (mm)    **Lo** = Spring Length (mm)    **De** = External Diameter (mm)

Tab. 13.184

Mod. 105M/105MH - Max pressure							
Pos.	Spring item code	Spring colour	d	Lo	De	Min.	Max
1	2702280	White/Red	5.5	60	35	30	65
2	2702450	Red	6	60		65.001	90

**d** = Wire Diameter (mm)    **Lo** = Spring Length (mm)    **De** = External Diameter (mm)

Tab. 13.185

Mod. 105M - Min pressure							
Pos.	Spring item code	Spring colour	d	Lo	De	Min.	Max
1	2700713	Green	2.3	40	15	3	7
2	2700750	Black	2.5			7.001	16
3	2700985	Brown	3			16.001	44

**d** = Wire Diameter (mm)    **Lo** = Spring Length (mm)    **De** = External Diameter (mm)

Tab. 13.186

Mod. 105MH - Min pressure							
Pos.	Spring item code	Spring colour	d	Lo	De	Min.	Max
1	2700985	Brown	3	40	15	44	60
	2700980	Blue	3	35			
2	2700985	Brown	3	40		60.001	90
	2700985	Brown	3				

**d** = Wire Diameter (mm)    **Lo** = Spring Length (mm)    **De** = External Diameter (mm)

Tab. 13.187

### 13.3 - M/A ACCELERATOR VALVE CALIBRATION TABLES

M/A							
Pos.	Spring item code	Spring colour	d	Lo	De	Min.	Max
1	2701260	White	3.5	60	35	0.3	1
2	2701530	Yellow	4			1,001	2,1
3	2702070	Orange	5			2,101	5.5
4	2702450	Red	6			5,501	11
5	2702815	Green	7			11.001	20

**d** = Wire Diameter (mm)    **Lo** = Spring Length (mm)    **De** = External Diameter (mm)

Tab. 13.188

M/A 1							
Pos.	Spring item code	Spring colour	d	Lo	De	Min.	Max
1	2702820	Blue	7	100	35	20	33
2	2703045	Brown	7,5			33,001	43
3	2703224	Grey	8			43.001	63

**d** = Wire Diameter (mm)    **Lo** = Spring Length (mm)    **De** = External Diameter (mm)

Tab. 13.189

M/A 2							
Pos.	Spring item code	Spring colour	d	Lo	De	Min.	Max
1	2703224	Grey	8	100	35	40	75

**d** = Wire Diameter (mm)    **Lo** = Spring Length (mm)    **De** = External Diameter (mm)

Tab. 13.190

PAGE INTENTIONALLY LEFT BLANK

TM0006ENG

