

# Aperflux 851

High medium pressure gas regulator



Revision D - Edition 02/2026

**USER, MAINTENANCE  
AND WARNING MANUAL**

PAGE INTENTIONALLY LEFT BLANK

# 1 - INTRODUCTION

## FOREWORD

All rights reserved. No part of this publication may be reproduced, distributed, translated into other languages or transmitted by any electronic or mechanical media, including photocopies, recording or any other storage and retrieval system, for any other purposes that are not exclusively the personal use of the buyer, without the express written permission of the Manufacturer.

The manufacturer is in no way responsible for the consequences of operations carried out in a manner not in accordance with the manual.

## GENERAL REMARKS

All operating, maintenance instructions and recommendations described in this manual must be observed. In order to obtain the best performance and to keep the equipment in efficient condition, the manufacturer recommends that maintenance operations be carried out regularly.

It is of particular importance that the personnel responsible for the equipment be trained in its use, maintenance and application of the safety instructions and procedures indicated in this manual.

**COPYRIGHT 2026**

**© PIETRO FIORENTINI S.P.A.**

PAGE INTENTIONALLY LEFT BLANK

## 1.1 - REVISION HISTORY

Revision index	Date
<b>A</b>	08/2021
<b>B</b>	02/2026
<b>C</b>	07/2024
<b>D</b>	02/2026

Tab. 1.1

# INDEX

<b>1 - INTRODUCTION .....</b>	<b>3</b>
1.1 - REVISION HISTORY.....	5
<b>2 - GENERAL INFORMATION .....</b>	<b>11</b>
2.1 - MANUFACTURER IDENTIFICATION .....	11
2.2 - IDENTIFICATION OF THE PRODUCT .....	11
2.3 - REGULATORY FRAMEWORK.....	11
2.4 - WARRANTY .....	11
2.5 - ADDRESSEES, SUPPLY AND STORAGE OF THE MANUAL .....	12
2.6 - SYMBOLS USED IN THE MANUAL.....	13
2.7 - APPLIED RATING PLATES .....	14
2.7.1 - GLOSSARY FOR RATING PLATES.....	16
2.8 - GLOSSARY OF UNITS OF MEASUREMENT .....	18
2.9 - QUALIFIED PROFESSIONAL FIGURES.....	19
<b>3 - SAFETY .....</b>	<b>21</b>
3.1 - GENERAL SAFETY WARNINGS.....	21
3.2 - PERSONAL PROTECTIVE EQUIPMENT.....	22
3.3 - RESIDUAL RISKS .....	23
3.3.1 - TABLE SHOWING RESIDUAL RISKS DUE TO PRESSURE .....	24
3.3.2 - TABLE OF RESIDUAL RISKS FOR POTENTIALLY EXPLOSIVE ATMOSPHERES .....	26
3.4 - OBLIGATIONS AND PROHIBITIONS .....	28
3.5 - SAFETY PICTOGRAMS .....	29
3.6 - NOISE LEVEL .....	29

## 4 - DESCRIPTION AND OPERATION ..... 31

4.1 - GENERAL DESCRIPTION .....	31
4.1.1 - REGULATOR REACTION MODES.....	32
4.2 - OPERATION.....	32
4.3 - DESIGNED USE.....	34
4.3.1 - INTENDED USE .....	34
4.3.2 - REASONABLY FORESEEABLE MISUSE .....	34
4.3.3 - TYPES OF FLUIDS .....	34
4.4 - TECHNICAL FEATURES/PERFORMANCE .....	35
4.5 - POSSIBLE CONFIGURATIONS .....	36
4.5.1 - BUILT-IN SILENCER.....	37
4.5.2 - MONITOR .....	38
4.5.2.1 - BUILT-IN MONITOR .....	39
4.5.2.2 - M/A THROTTLE.....	42
4.5.3 - SLAM-SHUT VALVE .....	43
4.5.3.1 - INCORPORATED SB/82 SLAM-SHUT VALVE.....	44
4.5.3.2 - HB/97 BUILT-IN SLAM-SHUT VALVE.....	46
4.5.4 - SLAM-SHUT VALVE PRESSURE SWITCHES .....	48

## 5 - TRANSPORT AND HANDLING ..... 51

5.1 - SPECIFIC WARNINGS FOR TRANSPORT AND HANDLING .....	51
5.1.1 - PACKAGING AND FASTENERS USED FOR TRANSPORT .....	52
5.2 - PHYSICAL CHARACTERISTICS OF THE EQUIPMENT .....	54
5.2.1 - APERFLUX 851 .....	54
5.2.2 - APERFLUX 851 + DB/851.....	56
5.2.3 - APERFLUX 851 + PM/819 .....	58
5.2.4 - APERFLUX 851 + SB/82 OR + HB/97.....	60
5.2.5 - APERFLUX 851 + DB/851 + PM/819.....	62
5.2.6 - APERFLUX 851 + DB/851 + SB/82 OR + HB/97 .....	64
5.3 - EQUIPMENT ANCHORING AND LIFTING METHOD.....	66
5.3.1 - FORKLIFT HANDLING METHOD.....	67
5.3.2 - CRANE HANDLING METHOD .....	69
5.4 - PACKAGING REMOVAL.....	70
5.4.1 - PACKAGING DISPOSAL .....	70
5.5 - STORAGE AND ENVIRONMENTAL CONDITIONS .....	71
5.5.1 - PRE-INSTALLATION WARNINGS AFTER PROLONGED STORAGE .....	71

## 6 - INSTALLATION ..... 73

6.1 - INSTALLATION PRE-REQUISITES.....	73
6.1.1 - ENVIRONMENTAL CONDITIONS ALLOWED.....	73
6.1.2 - CHECKS BEFORE INSTALLATION.....	74
6.2 - SPECIFIC SAFETY INSTRUCTIONS FOR THE INSTALLATION PHASE .....	75
6.3 - GENERAL INFORMATION ON CONNECTIONS .....	76
6.4 - REGULATOR INSTALLATION POSITIONS.....	77
6.5 - INSTALLATION PROCEDURE .....	78
6.5.1 - EQUIPMENT INSTALLATION PROCEDURE .....	78
6.5.2 - CONNECTION OF THE SENSING LINES TO THE DOWNSTREAM PIPING.....	78
6.6 - POST-INSTALLATION AND PRE-COMMISSIONING CHECKS .....	80

## 7 - COMMISSIONING/MAINTENANCE EQUIPMENT..... 81

7.1 - LIST OF EQUIPMENT.....	81
7.2 - EQUIPMENT NEEDED FOR THE DIFFERENT CONFIGURATIONS.....	82

## 8 - COMMISSIONING ..... 85

8.1 - GENERAL WARNINGS .....	85
8.1.1 - SAFETY REQUIREMENTS FOR COMMISSIONING .....	85
8.2 - PRELIMINARY PROCEDURES FOR COMMISSIONING .....	86
8.3 - PROPER COMMISSIONING CHECK .....	87
8.4 - CALIBRATION OF ANY ACCESSORIES.....	87
8.5 - REGULATOR COMMISSIONING PROCEDURE .....	88
8.6 - PROCEDURE FOR COMMISSIONING THE APERFLUX 851 REGULATOR WITH PM/819 BUILT-IN MONITOR.....	90
8.7 - COMMISSIONING PROCEDURE FOR THE APERFLUX 851 REGULATOR WITH BUILT-IN PM/819 MONITOR AND M/A THROTTLE.....	92
8.8 - COMMISSIONING PROCEDURE FOR THE APERFLUX 851 REGULATOR WITH BUILT-IN SLAM-SHUT VALVE SB/82 .....	94
8.8.1 - CHECKING THE SB/82 SLAM-SHUT VALVE FOR PROPER SEALING WHEN CLOSING .....	94
8.8.2 - CALIBRATION PROCEDURE FOR PRESSURE SWITCHES MODELS 02M/102MH ÷ 105M/105MH .....	95
8.9 - COMMISSIONING PROCEDURE FOR APERFLUX 851 REGULATOR WITH INTEGRATED HB/97 SLAM SHUT VALVE.....	97
8.9.1 - CHECKING THE HB/97 INCORPORATED SLAM-SHUT VALVE FOR SEALING WHEN CLOSING .....	97
8.9.2 - LINE OFF 2.0 COMMISSIONING AND CALIBRATION PROCEDURE FOR HB/97 BUILT-IN SLAM-SHUT VALVE .....	98
8.10 - CALIBRATION OF THE PRESSURE SWITCH FOR LINE OFF 2.0.....	99
8.11 - DEVICE CALIBRATION.....	100
8.11.1 - 200 SERIES AND 300 SERIES PILOTS .....	100
8.11.2 - PRESSURE SWITCHES MODELS 102M/102MH - 105M/105MH.....	101

## 9 - MAINTENANCE AND FUNCTIONAL CHECKS..... 103

9.1 - GENERAL WARNINGS .....	103
9.2 - PERIODICALLY CHECKING AND INSPECTING THE EQUIPMENT FOR PROPER OPERATION.....	105
9.3 - ROUTINE MAINTENANCE .....	106
9.3.1 - GENERAL SAFETY WARNINGS.....	106
9.3.2 - REPLACEMENT FREQUENCY FOR COMPONENTS SUBJECT TO WEAR .....	107
9.4 - ROUTINE MAINTENANCE PROCEDURES.....	109
9.4.1 - TIGHTENING TORQUES APERFLUX 851.....	110
9.4.2 - REPLACING ELEMENTS SUBJECT TO WEAR AND ABRASION.....	141
9.4.3 - REGULATOR APERFLUX 851 1" ÷ 3" .....	142
9.4.4 - MAINTENANCE OF THE 300/A SERIES PILOT + AR100 THROTTLE VALVE.....	162
9.4.5 - DB/851 SILENCER MAINTENANCE.....	184
9.4.6 - PM/819 BUILT-IN MONITOR MAINTENANCE.....	200
9.4.7 - 200/A SERIES PILOT + PRE-REDUCER R14/A MAINTENANCE.....	230
9.4.8 - M/A THROTTLE VALVE MAINTENANCE .....	244
9.4.9 - MAINTENANCE OF THE BUILT-IN SLAM SHUT VALVE SB/82 .....	248
9.4.10 - HP2/2 BYPASS DEVICE MAINTENANCE PROCEDURE.....	273
9.4.11 - MAINTENANCE PROCEDURE FOR PRESSURE SWITCHES MODELS 102M/102MH - 105M/105MH274	
9.4.12 - HB/97 BUILT-IN SLAM-SHUT VALVE MAINTENANCE PROCEDURE .....	286
9.4.13 - LINE OFF 2.0 MAINTENANCE PROCEDURE .....	296
9.4.14 - PROCEDURE FOR RECOMMISSIONING AFTER MAINTENANCE .....	317

## 10 - TROUBLESHOOTING..... 319

10.1 -GENERAL WARNINGS .....	319
10.2 -OPERATOR QUALIFICATION SPECIFICATION.....	320
10.3 -TROUBLESHOOTING PROCEDURES .....	320
10.4 -TROUBLESHOOTING TABLES .....	321
10.4.1 -TROUBLESHOOTING REGULATOR APERFLUX 851 .....	321
10.4.2 - DB/851 SILENCER TROUBLESHOOTING .....	323
10.4.3 - APM/819 BUILT-IN MONITOR TROUBLESHOOTING .....	324
10.4.4 - SB/82 BUILT-IN SLAM-SHUT VALVE TROUBLESHOOTING.....	327
10.4.5 - HB/97 BUILT-IN SLAM-SHUT VALVE TROUBLESHOOTING.....	329

## 11 - UNINSTALLATION AND DISPOSAL ..... 333

11.1 -GENERAL SAFETY WARNINGS.....	333
11.2 -QUALIFICATION OF THE OPERATORS IN CHARGE.....	333
11.3 -UNINSTALLATION.....	333
11.4 -INFORMATION REQUIRED IN CASE OF RE-INSTALLATION.....	333
11.5 -DISPOSAL INFORMATION.....	334

**12 - RECOMMENDED SPARE PARTS ..... 335**

12.1 -GENERAL WARNINGS .....	335
12.2 -HOW TO REQUEST SPARE PARTS.....	335

**13 - CALIBRATION TABLES ..... 337**

13.1 -300 SERIES PILOT CALIBRATION TABLES .....	337
13.2 -200 SERIES PILOT CALIBRATION TABLES .....	338
13.3 -CALIBRATION TABLES FOR PRESSURE SWITCHES MOD. 100.....	339
13.4 -M/A ACCELERATOR VALVE CALIBRATION TABLES.....	342

## 2 - GENERAL INFORMATION

### 2.1 - MANUFACTURER IDENTIFICATION

<b>Manufacturer</b>	PIETRO FIORENTINI S.P.A.
<b>Address</b>	Via Enrico Fermi, 8/10 36057 Arcugnano (VI) - ITALY <b>Tel. +39 0444 968511 Fax +39 0444 960468</b> <b>www.fiorentini.com arcugnano@fiorentini.com</b>

Tab. 2.2

### 2.2 - IDENTIFICATION OF THE PRODUCT

<b>Equipment</b>	HIGH PRESSURE REGULATOR
<b>Model</b>	APERFLUX 851

Tab. 2.3

### 2.3 - REGULATORY FRAMEWORK

PIETRO FIORENTINI S.P.A. with registered office in Arcugnano (Italy) - Via E. Fermi, 8/10, declares under its sole responsibility that the Aperflux 851 series equipment, which is the subject of this manual, is designed, manufactured, tested and controlled in accordance with the requirements of the EN 334 gas pressure regulator standard.

The equipment meets the requirements of Directive 2014/68/EU (Pressure Equipment Directive PED). The assessment procedure adopted is in accordance with module H1 as per Annex III of the Directive.

#### **NOTICE!**

**The declaration of conformity in its original version is delivered together with the equipment and this operating and warning manual.**

### 2.4 - WARRANTY

PIETRO FIORENTINI S.P.A. guarantees that the equipment was manufactured using the best materials, with high quality workmanship, and complies with the quality requirements, specifications and performance set out in the order.

The warranty shall be considered null and void and PIETRO FIORENTINI S.P.A. shall not be liable for any damage and/or malfunctions:

- due to any acts or omissions of the purchaser or end-user, or any of their carriers, employees, agents, or any third party or entity;
- in the event that the purchaser, or a third party, makes changes to the equipment supplied by PIETRO FIORENTINI S.P.A. without the prior written approval of the latter;
- in the event of failure by the purchaser to comply with the instructions contained in these instructions, as provided by PIETRO FIORENTINI S.P.A.

#### **NOTICE!**

**The warranty conditions are specified in the commercial contract.**

## 2.5 - ADDRESSEES, SUPPLY AND STORAGE OF THE MANUAL

The instruction manual is intended for qualified operator responsible for using and managing the equipment throughout its service life.

It contains the necessary information to properly use the equipment and keep its functional and qualitative characteristics unchanged over time. All information and warnings for safe, correct use are also provided.

The manual, as well as the declaration of conformity and/or test certificate, is an integral part of the equipment and must always accompany it whenever it is moved or resold. It is up to the user to keep this documentation intact for reference throughout the lifespan of the equipment.

### **WARNING!**

**Removing, rewriting or editing the pages of the manual and their contents is not allowed.**



**Keep the instruction manual near the equipment, in an accessible place known by all qualified technicians involved in using and running it.**

**PIETRO FIORENTINI S.p.A. shall not be held liable for any damage to people, animals and property caused by failure to adhere to the warnings and operating procedures described in this manual.**

The original manual has been drawn up in Italian.

Any translations into additional languages are to be made from the original instructions.

## 2.6 - SYMBOLS USED IN THE MANUAL

Symbol	Definition
	Symbol used to identify important warnings for the safety of the operator and/or equipment.
	Symbol used to identify information of particular importance in the manual. The information may also concern the safety of the personnel involved in using the equipment.
	Obligation to consult the instruction manual/booklet. Indicates a requirement for the personnel to refer to (and understand) the operating and warning instructions of the machine before working with or on it.

Tab. 2.4

### HAZARD!

Alerts to a hazard with a high level of risk, an imminent hazardous situation which, if not prevented, will result in death or severe damage.

### WARNING!

Alerts to a hazard with a medium level of risk, a potentially hazardous situation which, if not prevented, may result in death or severe damage.

### ATTENTION!

Alerts to a hazard with a low level of risk, a potentially hazardous situation which, if not prevented, could result in minor or moderate damage.

### NOTICE!

Alerts to specific warnings, directions or notes of particular concern, that are not related to physical injury, as well as practices for which physical injury is not likely to occur.

## 2.7 - APPLIED RATING PLATES



### WARNING!

**Removing rating plates and/or replacing them with other plates is strictly not allowed.  
Should the plates be unintentionally damaged or removed, the customer must notify  
PIETRO FIORENTINI S.p.A.**

The equipment and its accessories are equipped with identification plates.

The plates specify identification details of the equipment and its accessories to be provided, if necessary, to PIETRO FIORENTINI S.p.A.

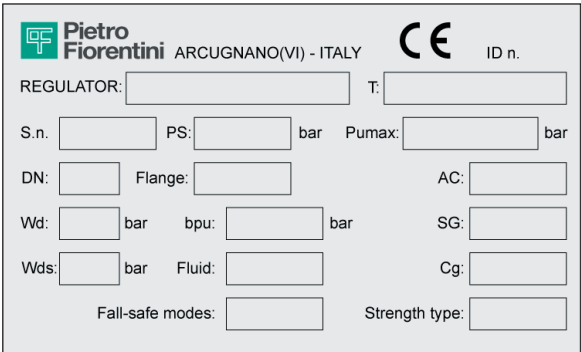
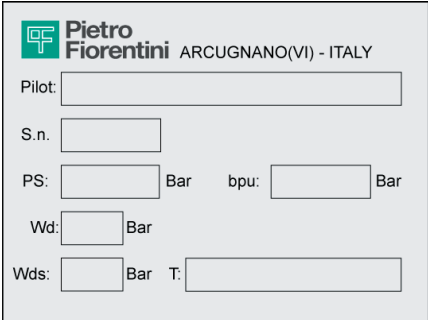
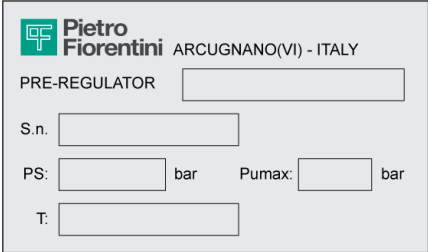
List of the rating plates applied:

Id.	Type	Image
1	RATING PLATE REGULATOR (EC version)	
2	RATING PLATE PILOT	
3	RATING PLATE PRE-REGULATOR	
4	RATING PLATE DB SILENCER	

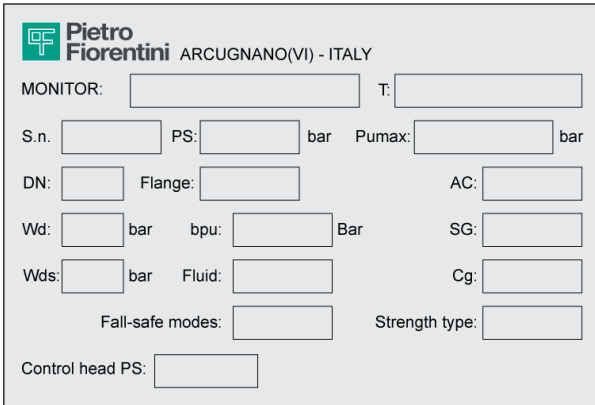
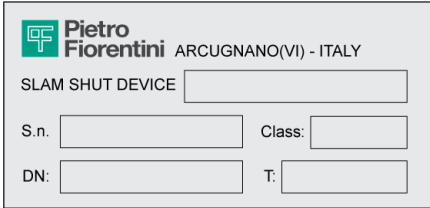
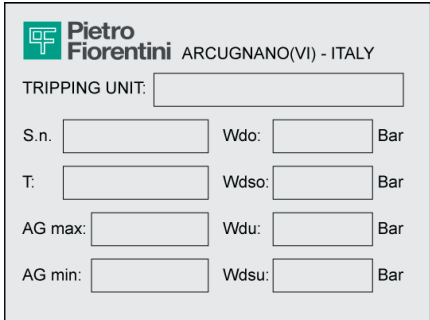
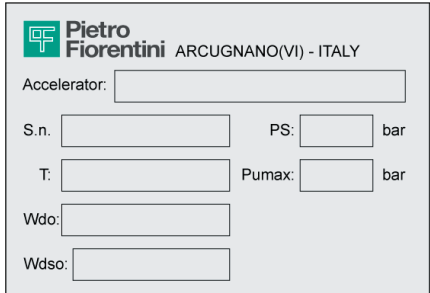
Id.	Type	Image
5	RATING PLATE MONITOR	 <p><b>Pietro Fiorentini</b> ARCUGNANO(VI) - ITALY</p> <p>MONITOR: <input type="text"/> T: <input type="text"/></p> <p>S.n. <input type="text"/> PS: <input type="text"/> bar Pumax: <input type="text"/> bar</p> <p>DN: <input type="text"/> Flange: <input type="text"/> AC: <input type="text"/></p> <p>Wd: <input type="text"/> bar bpu: <input type="text"/> Bar SG: <input type="text"/></p> <p>Wds: <input type="text"/> bar Fluid: <input type="text"/> Cg: <input type="text"/></p> <p>Fall-safe modes: <input type="text"/> Strength type: <input type="text"/></p> <p>Control head PS: <input type="text"/></p>
6	RATING PLATE SLAM-SHUT VALVE	 <p><b>Pietro Fiorentini</b> ARCUGNANO(VI) - ITALY</p> <p>SLAM SHUT DEVICE <input type="text"/></p> <p>S.n. <input type="text"/> Class: <input type="text"/></p> <p>DN: <input type="text"/> T: <input type="text"/></p>
7	RATING PLATE PRESSURE SWITCH	 <p><b>Pietro Fiorentini</b> ARCUGNANO(VI) - ITALY</p> <p>TRIPPING UNIT: <input type="text"/></p> <p>S.n. <input type="text"/> Wdo: <input type="text"/> Bar</p> <p>T: <input type="text"/> Wdso: <input type="text"/> Bar</p> <p>AG max: <input type="text"/> Wdu: <input type="text"/> Bar</p> <p>AG min: <input type="text"/> Wdsu: <input type="text"/> Bar</p>
8	RATING PLATE ACCELERATOR VALVE	 <p><b>Pietro Fiorentini</b> ARCUGNANO(VI) - ITALY</p> <p>Accelerator: <input type="text"/></p> <p>S.n. <input type="text"/> PS: <input type="text"/> bar</p> <p>T: <input type="text"/> Pumax: <input type="text"/> bar</p> <p>Wdo: <input type="text"/></p> <p>Wdso: <input type="text"/></p>

Tab. 2.5

### 2.7.1 - GLOSSARY FOR RATING PLATES

The terms and abbreviations used on the nameplates are described below:

Term	Description
<b>AC</b>	Accuracy class.
<b>AG max</b>	Accuracy class of pressure boosting slam-shut valves. "OPSO" (Over pressure shut off).
<b>AG min</b>	Accuracy class of safety devices for pressure drop. "UPS0" (Under pressure shut off).
<b>bpu</b>	Range of inlet pressure for which the regulator ensures a given accuracy class.
<b>CE</b>	Marking certifying compliance with applicable European directives.
<b>Cg</b>	Flow rate coefficient.
<b>Class</b>	Alphanumeric designation used for reference purposes related to a combination of mechanical and dimensional characteristics for flanges, in accordance with the relevant parts of EN 1759 series, which includes the word Class followed by a dimensionless whole number.
<b>DN</b>	Nominal size of connections.
<b>Fail safe mode</b>	Regulator reaction mode (Fail open or Fail close).
<b>Flange</b>	Type of flanged connections or type of connection thread.
<b>Fluid</b>	Type of fluid compatible with the equipment.
<b>ID n.</b>	Number of the Notified Body participating in the conformity assessment of the equipment.
<b>Pilot</b>	Pilot family.
<b>PS</b>	Maximum permissible pressure for which the equipment was designed.
<b>Pumax</b>	Maximum inlet pressure at which the regulator can operate continuously under specific conditions.
<b>REGULATOR</b>	Equipment family.
<b>SG</b>	Shut-off pressure class.
<b>Slam-shut device</b>	Slam-shut valve family.
<b>S.n.</b>	Equipment serial number.
<b>Strength type</b>	Strength class: Integral strength (IS) or differential strength (DS).
<b>T</b>	Permissible temperature range (min. and max.) that the equipment was designed for.
<b>Tripping unit</b>	Pressure switch family.
<b>Type</b>	Accessory type and family.
<b>Wd</b>	Full setpoint range that can be obtained from the regulator by adjusting and/or replacing certain components (e.g. replacement of valve seat or control element, e.g. spring).
<b>Wdo</b>	Full setpoint range with regard to tripping caused by increased pressure in the pressure switch built into the slam-shut valve. This range can be obtained by adjusting and/or replacing the components (for example, spring or sensitive element).
<b>Wds</b>	Full setpoint range that can be obtained from the regulator by adjusting but not replacing the components.
<b>Wdso</b>	Full setpoint range with regard to tripping caused by increased pressure in the pressure switch built into the slam-shut valve. This range can be obtained by adjusting but not replacing the components.
<b>Wdu</b>	Full setpoint range with regard to tripping caused by decreased pressure in the pressure switch built into the slam-shut valve. This range can be obtained by adjusting and/or replacing the components (for example, spring or sensitive element).

Term	Description
<b>Wdsu</b>	Full setpoint range with regard to tripping caused by decreased pressure in the pressure switch built into the slam-shut valve. This range can be obtained by adjusting but not replacing the components.

Tab. 2.6

## 2.8 - GLOSSARY OF UNITS OF MEASUREMENT

Type of measurement	Unit of measurement	Description
<b>Volumetric flow rate</b>	Stm <sup>3</sup> /h	Standard cubic metres per hour
	Scfh	Standard cubic feet per hour
<b>Pressure</b>	bar	Unit of measurement in the CGS system
	psi	Pounds per square inch
	"wc	water column inch
	Pa	Pascal
<b>Temperature</b>	°C	Degree centigrade
	°F	Fahrenheit degree
	K	Kelvin
<b>Tightening torque</b>	Nm	Newton metre
	ft-lbs	Foot per pound
<b>Sound pressure</b>	dB	Decibel
<b>Other measurements</b>	V	Volt
	W	Watt
	Ω	Ohm

Tab. 2.7

## 2.9 - QUALIFIED PROFESSIONAL FIGURES

Qualified operators in charge of using and managing the equipment throughout its technical service life:

Professional figure	Definition
<b>Mechanical maintenance technician</b>	<p>Qualified technician able to:</p> <ul style="list-style-type: none"> <li>perform preventive/corrective maintenance operations on all mechanical parts of the equipment subject to maintenance or repair;</li> <li>access all device parts for visual inspection, equipment checks, adjustments and settings.</li> </ul> <p>The maintenance mechanical technician is not authorised to operate on live electrical systems (if any).</p>
<b>Mechanical electric</b>	<p>Qualified technician able to:</p> <ul style="list-style-type: none"> <li>perform preventive/corrective maintenance operations on all electrical parts of the device subject to maintenance or repair;</li> <li>read wiring diagrams and check the correct functional cycle;</li> <li>perform adjustments and operate on electrical systems for maintenance, repair and replacement of worn parts.</li> </ul> <p>The electrical maintenance technician can operate in the presence of voltage inside electrical panels, junction boxes, control equipment etc. only if he/she is deemed to be suitable (S.P.).</p> <p>For general requirements, refer to the IEC EN 50110-1:2014 standard.</p>
<b>Worker in charge of transport, handling, unloading and placement on site</b>	<p>Operator qualified to:</p> <ul style="list-style-type: none"> <li>the use of lifting equipment</li> <li>handle materials and equipment.</li> </ul> <p>The equipment must be lifted and handled strictly in accordance with the instructions provided by the manufacturer as well as the regulations in force at the place where the equipment is installed.</p>
<b>Installer</b>	<p>Qualified operator able to:</p> <ul style="list-style-type: none"> <li>carry out all the operations necessary to properly install the equipment safely;</li> <li>perform all the operations necessary to properly operate the equipment and system safely.</li> </ul>
<b>User's technician</b>	<p>Technician trained and authorized to use and manage the equipment for the activities for which it was supplied. They must:</p> <ul style="list-style-type: none"> <li>be able to perform all operations required for the proper functioning of the equipment and the system, and for their safety and that of any personnel present;</li> <li>have proven experience in properly using the equipment similar to that described in this manual, and be trained, informed and instructed in this regard.</li> </ul> <p>The technician may carry out maintenance only if authorised/qualified to do so.</p>

Tab. 2.8

PAGE INTENTIONALLY LEFT BLANK

## 3 - SAFETY

### 3.1 - GENERAL SAFETY WARNINGS

#### WARNING!

The equipment described in this manual is:

- a device subjected to pressure in pressurised systems;
- normally installed in systems carrying flammable gases (for example: natural gas).

#### WARNING!

If the gas used is a combustible gas, the installation area of the equipment is defined as a 'danger zone' as there are residual risks that potentially explosive atmospheres may be generated.

In "danger zones" and in the immediate vicinity, the following are required:

- there must not be any effective sources of ignition;
- no smoking.

#### ATTENTION!

Authorised operators must not carry out operations or services on their own initiative that do not fall within their competence.

Never operate the equipment:

- while under the influence of intoxicating substances such as alcohol;
- if you are using drugs that may slow reaction times.

#### NOTICE!

The employer must train and inform operators on how to behave during operations and on the equipment to be used.

Before installation, commissioning or maintenance, operators must:









- take note of the safety regulations applicable to the place of installation they are working in;
- obtain the necessary permits to operate when required;
- wear the personal protective equipment required by the procedures described in this instruction manual;
- ensure that the required collective protective equipment and safety information are available in the area they are operating in;

### 3.2 - PERSONAL PROTECTIVE EQUIPMENT

“Tab. 3.9” shows the personal protective equipment (PPE) and its description. An obligation is associated with each symbol.

Personal protective equipment means any equipment intended to be worn by the worker in order to protect them against one or several risks that are likely to threaten their safety or health during work.

For the operators in charge, depending on the type of work requested, the most appropriate PPE of the following will be reported and must be used:

Symbol	Meaning
	<b>Obligation to use safety or insulated gloves.</b> Indicates a requirement for the personnel to use safety or insulated gloves.
	<b>Obligation to use safety goggles.</b> Indicates a requirement for personnel to use protective goggles for eye protection.
	<b>Obligation to use safety shoes.</b> Indicates a requirement for personnel to use accident-prevention safety shoes.
	<b>Obligation to use noise protection equipment.</b> Indicates a requirement for the personnel to use ear muffs or ear plugs to protect their hearing.
	<b>Obligation to wear protective clothing.</b> Indicates a requirement for personnel to wear specific protective clothing.
	<b>Obligation to use a protective mask.</b> Indicates a requirement for the personnel to use respiratory masks in the event of a chemical risk.
	<b>Obligation to use a protective helmet.</b> Indicates a requirement for the personnel to use protective helmets.
	<b>Obligation to wear high visibility vests.</b> Indicates a requirement for the personnel to use high visibility vests.

Tab. 3.9

#### **WARNING!**

Each licensed operator is obliged to:

- **take care of his/her own health and safety and that of other people in the workplace who are affected by his/her actions or omissions, in accordance with the training, instructions and equipment provided by the employer;**
- **appropriately use the PPE made available;**
- **immediately report to the employer, the manager or the person in charge any deficiencies in the equipment and devices, as well as any dangerous conditions they may become aware of.**

### **3.3 - RESIDUAL RISKS**

In accordance with the requirements of directive PED 2014/68/EU, point 1.2 of Annex I, below is an assessment of the risks associated with the equipment and an indication of the principles adopted for their prevention, according to the following classification:

- a) Elimination and/or reduction of the risk.
- b) Application of appropriate protective measures.
- c) information to users about residual risks.

### 3.3.1 - TABLE SHOWING RESIDUAL RISKS DUE TO PRESSURE

Risk and Hazard	Event and Cause	Effect and Consequence	Solution and Prevention
<b>Pressurised gas leakage.</b> <b>leakage</b> <b>Projection of metallic and non-metallic pressurised parts.</b>	<ul style="list-style-type: none"> <li>• violent impact;</li> <li>• impact (also due to falling, improper handling, etc.).</li> </ul>	<ul style="list-style-type: none"> <li>• deformation;</li> <li>• breakage of connections and, if pressurised, even burst.</li> </ul>	a. Handling and installation with appropriate devices to avoid localised stress. b. Installation in suitable places and spaces with appropriate guards and packaging. c. Information in the instructions for use and warning.
<b>Pressurised gas leakage.</b> <b>leakage</b> <b>Projection of metallic and non-metallic pressurised parts.</b> <b>metallic and not in leakage</b>	<ul style="list-style-type: none"> <li>• Use of inappropriate fluids.</li> </ul>	<ul style="list-style-type: none"> <li>• corrosion;</li> <li>• embrittlement;</li> <li>• explosion.</li> </ul>	a. The user must check compliance of the used fluid with the specifications on the data plate.
<b>Pressurised gas leakage.</b> <b>leakage</b> <b>Projection of metallic and non-metallic pressurised parts.</b> <b>metallic and not in leakage</b>	<ul style="list-style-type: none"> <li>• operation at temperatures below the minimum permissible temperature.</li> </ul>	<ul style="list-style-type: none"> <li>• embrittlement;</li> <li>• breaking;</li> <li>• explosion.</li> </ul>	a. Install in places where the temperature is not below the minimum permissible temperature and/or insulate the equipment adequately. b. The minimum temperature allowed is indicated on the data plate.
<b>Pressurised gas leakage.</b> <b>leakage</b> <b>Projection of metallic and non-metallic pressurised parts.</b> <b>Explosion.</b>	<ul style="list-style-type: none"> <li>• overpressure or exceeding of the rated limit values (maximum pressure allowed)</li> </ul>	<ul style="list-style-type: none"> <li>• explosion;</li> <li>• breaks;</li> <li>• cracks;</li> <li>• permanent deformation.</li> </ul>	a. The device has appropriate design safety margins. b. The user must check the maximum pressure applicable to the equipment. c. The maximum allowable pressure is highlighted on the appropriate plate on the equipment.
<b>Falling of the equipment.</b>	<ul style="list-style-type: none"> <li>• dangerous handling.</li> </ul>	<ul style="list-style-type: none"> <li>• deformation;</li> <li>• cracking;</li> <li>• breaking.</li> </ul>	b. The user must have suitably sized lifting equipment. c. The above requirements are referred to in the equipment use and warning manual.
<b>Pressurised fluid leakage</b> <b>Projection of metallic and non-metallic pressurised parts.</b> <b>metallic and not in leakage</b>	<ul style="list-style-type: none"> <li>• incorrect fixing of the equipment.</li> </ul>	<ul style="list-style-type: none"> <li>• deformation;</li> <li>• breaking.</li> </ul>	a. The device is equipped with unified type process connections and press fittings. b. The user must ensure correct fixing to the line. c. Directions in the instructions for use and warning.

Risk and Hazard	Event and Cause	Effect and Consequence	Solution and Prevention
<b>Explosion of the device.</b> <b>Pressurised fluid leakage</b> <b>Projection of metallic and non-metallic pressurised parts.</b> <b>metallic.</b>	<ul style="list-style-type: none"> <li>operation at temperatures above the maximum permissible temperature.</li> </ul>	<ul style="list-style-type: none"> <li>reduction of mechanical resistance and breakage of the device;</li> <li>explosion.</li> </ul>	a. The user must equip the system with suitable control and safety devices. b. The maximum temperature allowed is indicated on the data plate.
<b>Pressurised gas leakage</b>	<ul style="list-style-type: none"> <li>equipment maintenance with the system running.</li> </ul>	<ul style="list-style-type: none"> <li>inappropriate opening of pressurised chambers.</li> </ul>	a. The user must perform any maintenance with the equipment not running. b. The above requirements are referred to in the use and warning instructions.
<b>Pressurised gas leakage</b> <b>Projection of metallic and non-metallic pressurised parts.</b> <b>metallic and not in leakage</b>	<ul style="list-style-type: none"> <li>external loads bearing on the device.</li> </ul>	<ul style="list-style-type: none"> <li>deformation;</li> <li>cracking and slot formation;</li> <li>if pressurised, also bursting.</li> </ul>	a. With the exclusion of what is set out in the design, the user must verify that no additional concentrated load bears on the device.
<b>Pressurised gas leakage</b> <b>Projection of metallic and non-metallic pressurised parts.</b> <b>metallic and not in leakage</b>	<ul style="list-style-type: none"> <li>electrostatic potential, differential stray currents.</li> </ul>	<ul style="list-style-type: none"> <li>localised corrosion in the device.</li> </ul>	b. The user must equip the device with the necessary protection and earthing devices. c. The above requirements are referred to in the use and warning manual.
<b>Pressurised gas leakage</b> <b>Projection of metallic and non-metallic pressurised parts.</b> <b>metallic and not in leakage</b>	<ul style="list-style-type: none"> <li>humidity;</li> <li>environments with aggressive atmosphere.</li> </ul>	<ul style="list-style-type: none"> <li>deterioration of external surfaces;</li> <li>corrosion.</li> </ul>	a. The user must periodically check the state of conservation of the external surfaces. b. The above requirements are referred to in the use and warning instructions.

Tab. 3.10

### 3.3.2 - TABLE OF RESIDUAL RISKS FOR POTENTIALLY EXPLOSIVE ATMOSPHERES

“Tab. 3.11” shows the conditions that can lead to the generation of a potentially explosive atmosphere respectively for:

- APERFLUX 851 pressure regulator;
- PM/819 monitor;
- SB/82 or HB/97 slam shut valves.

Considering that the silencer does not have active functional parts, in this analysis it is considered an integral part of the APERFLUX 851 regulator.

The table is valid for use with natural gas with a density of no more than 0.8; for different densities, the installation and environmental conditions must also be evaluated.

#### **WARNING!**

**If the gas used is a combustible gas, the installation area of the equipment is defined as a 'danger zone' as there are residual risks that potentially explosive atmospheres may be generated.**

**There must be no effective sources of ignition in 'danger zones' and in close proximity thereto.**

Conditions operational	Atmosphere potentially explosive	Normative references	Management measures included in the instructions for use and warning
<b>First start-up</b>	No	<ul style="list-style-type: none"> <li>• During the production cycle and before the CE marking according to Directive 2014/68/EU, the external tightness of the equipment is checked at a value of 1.1 PS (in accordance with Standard EN 334).</li> <li>• Before commissioning, the external sealing of the system portion on which the equipment is installed is checked at a suitable pressure (in accordance with the provisions of standards EN 12186 and EN 12279).</li> </ul>	The instructions for use indicate the need to meet the requirements in Standards EN 12186 and EN 12279.
<b>Operation in normal conditions</b>	No	<p>The indications in the previous point apply, in addition:</p> <ul style="list-style-type: none"> <li>• the equipment is installed outdoors or in an environment with natural ventilation (in accordance with Standards EN 12186 and EN 12279);</li> <li>• the installation is subject to surveillance according to current national rules/good practice/the equipment manufacturer's instructions (in accordance with the provisions of Standard EN 12186 and Standard EN 12279).</li> </ul>	<p>The instructions for use indicate that:</p> <ul style="list-style-type: none"> <li>• any environment in which the equipment is installed must meet the requirement of Standards EN 12186 and EN 12279;</li> <li>• periodic checks and maintenance must be carried out during surveillance in accordance with the national rules in force (if any), and with the specific manufacturer's recommendations.</li> </ul>

Conditions operational	Atmosphere potentially explosive	Normative references	Management measures included in the instructions for use and warning
<b>Breakage of the control head diaphragm (malfunction)</b>	No	<p>This event must be considered a rare malfunction.</p> <p>All atmospheric pressure chambers delimited on at least one side by a diaphragm must be channelled to a safe area (in accordance with the provisions of Standard EN 12186 and Standard EN 12279).</p>	The instructions for use indicate the need to meet the requirements of Standards EN 12186 and EN 12279.
<b>Breakage of other parts non-metallic (malfunction)</b>	No	<p>This type of malfunction is not reasonably expected as it involves static seals (to the outside) that cannot generate any external leakage.</p>	-
<b>Decommissioning</b>	No	<ul style="list-style-type: none"> <li>The pressure of the system section in which the equipment is installed must be reduced with appropriate vent lines channelled to a safe area (in accordance with the provisions of Standard EN 12186 and Standard EN 12279).</li> <li>The residual gas must be discharged as indicated above.</li> </ul>	The instructions for use indicate the need to meet the requirements of Standards EN 12186 and EN 12279
<b>Reboot</b>	No	<ul style="list-style-type: none"> <li>After reassembling the regulator, carry out an external leakage test at a convenient pressure value as specified by the manufacturer.</li> <li>Before commissioning, the external sealing of the system portion on which the equipment is installed is checked at a suitable pressure (in accordance with the provisions of standards EN 12186 and EN 12279).</li> </ul>	<p>The instructions for use indicate:</p> <ul style="list-style-type: none"> <li>the minimum conditions for testing external leakage;</li> <li>the need to meet the requirements of Standards EN 12186 and EN 12279.</li> </ul>

Tab. 3.11

### 3.4 - OBLIGATIONS AND PROHIBITIONS

The following is a list of obligations and prohibitions to be observed for the safety of the operator.



- to carefully read and understand the instructions for use and warning;
- to check whether the downstream equipment is suitably sized according to the performance required of the regulator in the actual operating condition;
- before installing the equipment, to strictly refer to the details specified on the nameplates;
- to avoid violent shocks and impacts that could damage the equipment and, as a result, cause the pressurised fluid to leak.

It is strictly forbidden to:

- operate in various capacities on the equipment without the PPE indicated in the work procedures described in these use and warning instructions;
- operate in the presence of open flames or bring open flames close to the work area;
- smoke near the equipment or while working on it;
- use the equipment with parameters other than those indicated on the name plate;
- use the equipment with fluids other than those indicated on the rating plate and in these use and warning instructions;
- use the equipment outside the operating temperature range specified on the rating plate and in these use and warning instructions;
- service the equipment with the system portion, on which it is installed, in operation;
- install or use the equipment in environments other than those specified in these instructions for use and warning.

### 3.5 - SAFETY PICTOGRAMS

The following safety pictograms may be shown on the equipment and/or packaging PIETRO FIORENTINI S.p.A.:

Symbol	Definition
	Symbol used to identify an ELECTRICAL HAZARD.
	Symbol used to identify a GENERIC HAZARD.

Tab. 3.12

#### HAZARD!

**It is absolutely forbidden to remove the safety pictograms on the equipment.**

**The user is required to replace the safety pictograms which, following wear, removal or tampering, are illegible.**

### 3.6 - NOISE LEVEL

Depending on the operating conditions, use and required configuration, the equipment may generate noise other than that permitted by the regulations in force in the country of installation.

For the value of the noise generated by the equipment and further information, contact PIETRO FIORENTINI S.p.A.

#### ATTENTION!

**The obligation to use earmuffs or ear plugs to protect the operator's hearing remains in the event that the noise in the installation environment of the equipment (depending on specific operating conditions) exceeds the value of 85 dBA.**

PAGE INTENTIONALLY LEFT BLANK

## 4 - DESCRIPTION AND OPERATION

### 4.1 - GENERAL DESCRIPTION

The equipment APERFLUX 851 is a piloted pressure regulator for medium and high pressure which reduces the inlet gas pressure, keeping the downstream value stable even when the following varies:

- inlet pressure value;
- the required flow rate within the operating conditions of the equipment.

The main elements of the equipment are:

Pos.	Description	Pos.	Description
1	Main regulator	5	Main regulator body
2	Piloting unit	6	Valve seat
3	AR100 throttle valve	7	Pressure control element
4	300 series pilot	8	Control head

Tab. 4.13

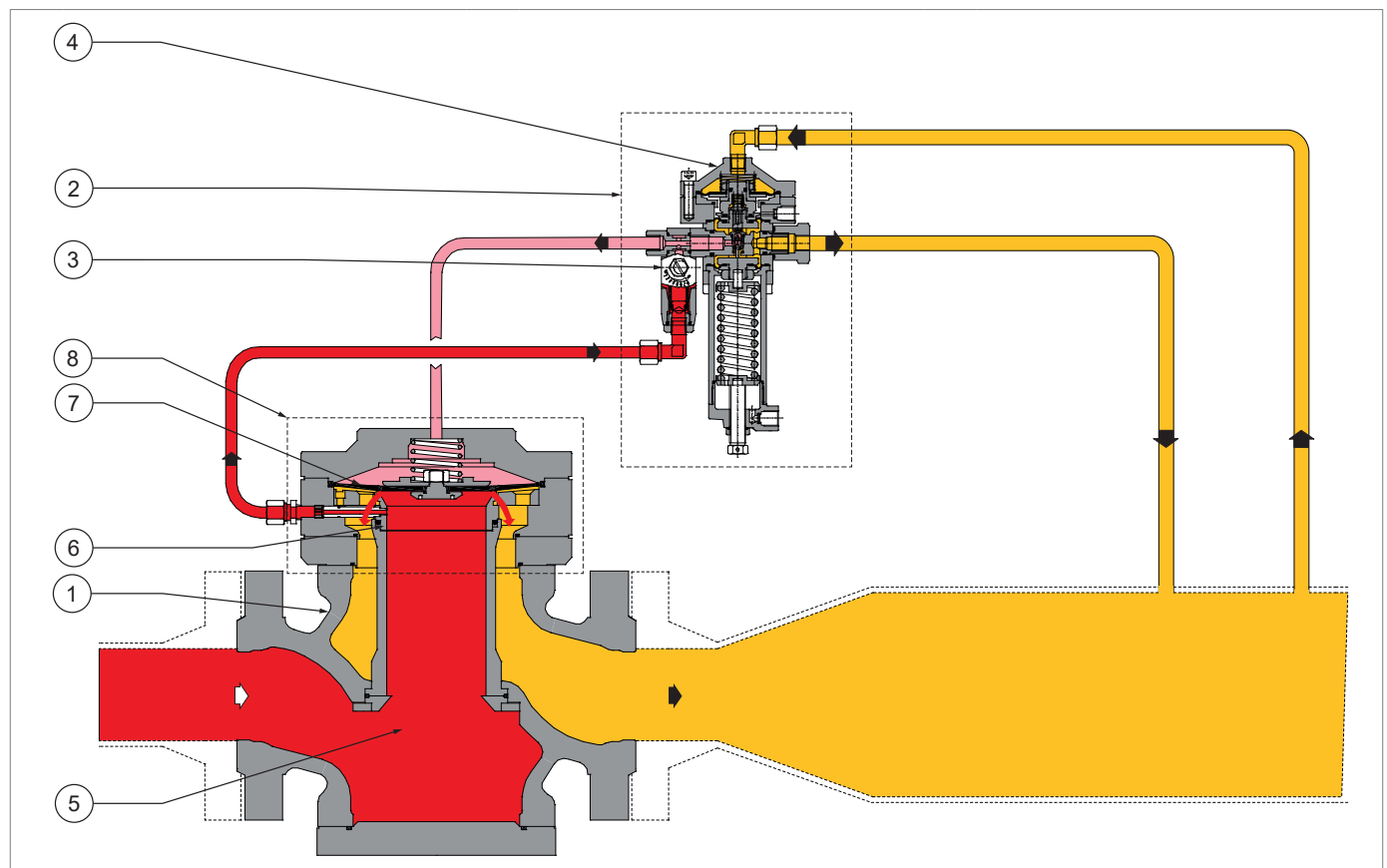

Fig. 4.1. General description APERFLUX 851

### 4.1.1 - REGULATOR REACTION MODES

The APERFLUX 851 equipment is a regulator piloted with a "fail open" reaction (on-opening reaction), that is, it opens in the event of:

- breakage of the pilot diaphragm(s);
- breakage of the pilot plug;
- no power supply in the pilot circuit.

### 4.2 - OPERATION

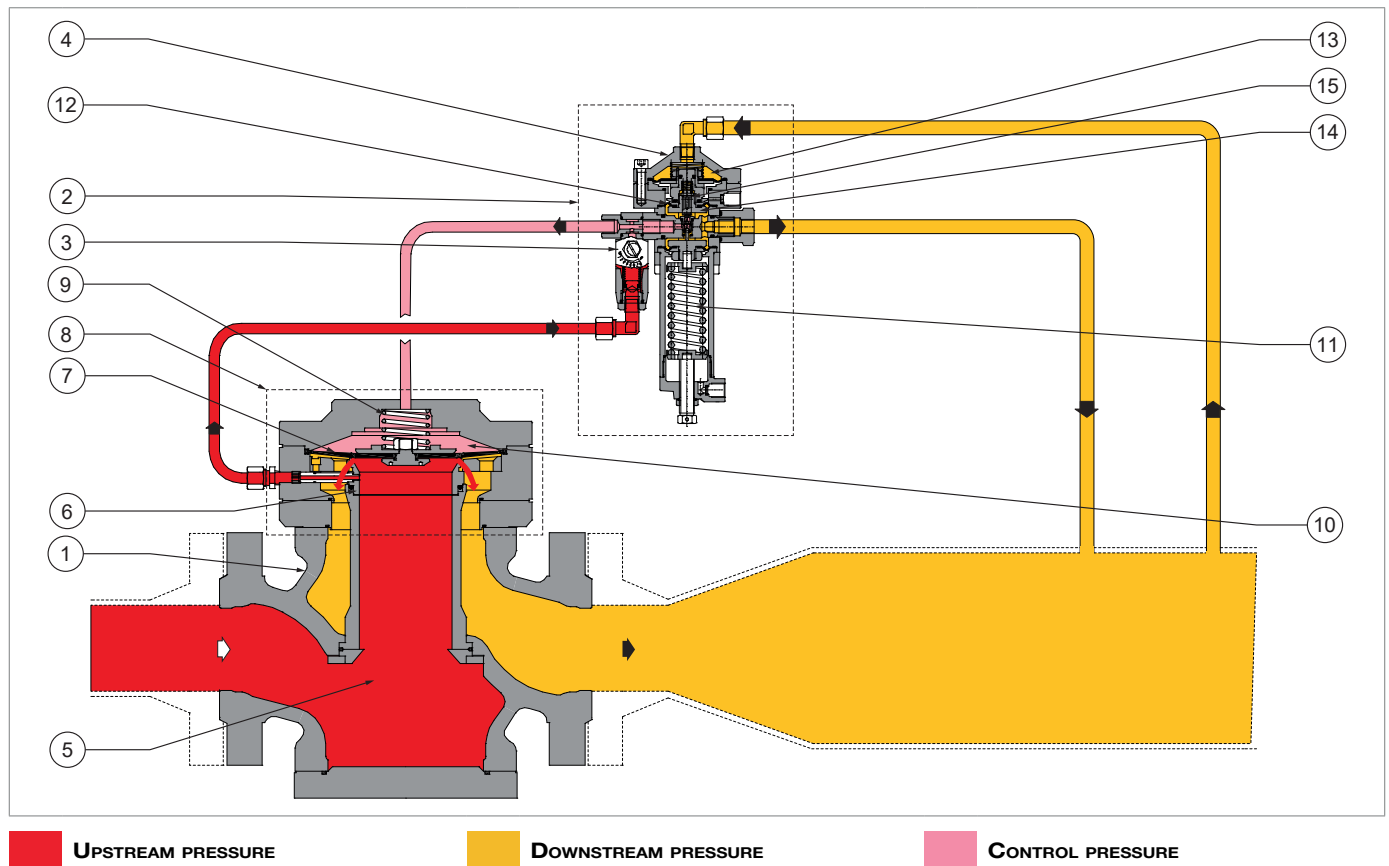

Fig. 4.2. Operation APERFLUX 851

In the control head (8), the pressure control element (7), if not pressurised, is kept in the closed position by the spring (9).

In normal operating conditions, the following forces act on the control element (7):

- on the upper side: spring load (9), thrust resulting from the control pressure ( $P_c$ ) in the control chamber (10) and weight of the mobile unit;
- on the lower side: thrusts deriving from the upstream ( $P_u$ ) and downstream ( $P_d$ ) pressure as well as residual dynamic components.

The gas used to feed the pilot (4) and the control chamber (10) is drawn upstream of the control element (7) at the upstream pressure ( $P_u$ ) and cleaned of solid contaminants by the filter incorporated in the AR100 throttle valve (3).

The  $P_c$  pressure value is adjusted by the pilot (4) by comparing:

- the load of the setting spring (11);
- the action of pressure  $P_d$  on the diaphragm (12) in the upper chamber (13).

During normal operation, the plug is positioned so that the control pressure ( $P_c$ ) above the control element (7) is such that the downstream pressure ( $P_d$ ) is maintained at around the selected value. If, during operation, the following should occur:

Operating conditions	Operating consequences	Outcome
<b>Decrease in downstream pressure (<math>P_d</math>) below the set value (<math>P_{ds}</math>), due to increase in required flow.</b>	Unbalancing of the mobile unit (14) causing: <ul style="list-style-type: none"> <li>• an increase in plug opening (15);</li> <li>• a decrease in control pressure (<math>P_c</math>).</li> </ul>	Increase in gas flow until the downstream pressure ( $P_d$ ) is restored to the set value ( $P_{ds}$ ).
<b>Increase in downstream pressure (<math>P_d</math>) above the set value (<math>P_{ds}</math>), due to decrease in required flow rate or increase in upstream pressure (<math>P_u</math>).</b>	Unbalance of the moving unit (14) against the calibration spring (11) causing: <ul style="list-style-type: none"> <li>• a partial closure of the plug (15) and the passage of a smaller quantity of gas;</li> <li>• the increase in the control pressure (<math>P_c</math>) due to the decrease in the pressure loss generated by the throttle valve (3).</li> </ul>	Decrease in gas flow rate until the pressure is restored to the set value ( $P_{ds}$ ).

Tab. 4.14

## 4.3 - DESIGNED USE

### 4.3.1 - INTENDED USE

The equipment in question is intended for:

Operation	Permitted	Unpermitted	Work environment
<b>Adjustment of the downstream pressure for:</b>	Gaseous, and non-corrosive, fluids that have been filtered beforehand.	<ul style="list-style-type: none"> <li>Liquids.</li> <li>Any product other than those permitted.</li> </ul>	Installations to carry and convey natural gas to networks for: <ul style="list-style-type: none"> <li>civil use;</li> <li>industrial use.</li> </ul>

Tab. 4.15

The equipment in question is used as a main controller and in-line monitor controller.

It was designed to be used exclusively within the limits specified on the rating plate and according to the instructions and limits of use referred to in this manual.

Safe work parameters are:

- use within the limits stated on the rating plate and in this manual;
- compliance with the user manual procedures;
- routine maintenance to be carried out when and how recommended;
- special maintenance to be carried out if required;
- do not tamper with and/or bypass the safety devices.

### 4.3.2 - REASONABLY FORESEEABLE MISUSE

Incorrect and reasonably foreseeable use means the use of the equipment in a way not foreseen in the phase but which can result from readily foreseeable human behaviour:

- corrosive fluids;
- fluids not properly treated upstream;
- liquids;
- instinctive reaction of an operator in the event of a malfunction, accident or breakdown while using the equipment;
- behaviour resulting from pressure to keep the machine running under all circumstances;
- behaviour resulting from carelessness;
- behaviour resulting from the use of the equipment by unauthorised and unsuitable people (children, disabled);
- using the equipment in a manner other than that referred to in paragraph "4.3.1 - Intended use".

Any use of the equipment other than the intended use must be previously approved in writing by PIETRO FIORENTINI S.p.A. If no written approval is provided, use shall be considered "improper".

In the event of improper use, PIETRO FIORENTINI S.p.A. shall not be held liable for any damage caused to people or property, and any type of warranty on the equipment shall be deemed void.

### 4.3.3 - TYPES OF FLUIDS

The equipment works with combustible gases used:

- in pressure control stations according to EN 12186 or EN 12279;
- in transmission and distribution networks.
- in commercial and industrial plants (after checking by contacting the Manufacturer).

#### NOTICE!

**The equipment may be also used with inert gases, subject to verification by contacting the manufacturer.**

#### 4.4 - TECHNICAL FEATURES/PERFORMANCE

The APERFLUX 851 equipment is a medium and high pressure regulator.

APERFLUX 851 is a 'top entry' type regulator that can be easily serviced and equipped with on-site accessories. The regulation system is balanced and guarantees a stable outlet pressure even when the inlet pressure varies.

The main specifications for this regulator are:

Technical features	
<b>Maximum allowable pressure</b>	Up to 100 bar
<b>Inlet gas temperature range</b>	-10 °C + 60 °C (class 1) -20 °C + 60 °C (class 2)
<b>Ambient temperature range</b>	-20 °C + 60 °C
<b>Inlet pressure range (bpu)</b>	1 - 85 bar
<b>Possible regulation range (Wd)</b>	0.8 - 74 bar (depending on the pilot installed)
<b>Minimum differential pressure</b>	0.5 bar (recommended > 2 bar)
<b>Accuracy class (AC)</b>	up to 1,5 (depending on operating conditions)
<b>Lock up pressure class (SG)</b>	up to 2.5 (depending on operating conditions)

Tab. 4.16

Cg, Kg and K1 coefficients							
<b>Nominal diameter [mm]</b>	25	50	80	100	150	200	250
<b>Size [inches]</b>	1"	2"	3"	4"	6"	8"	10"
<b>Coefficient Cg</b>	480	1550	3790	5554	11112	17316	24548
<b>Kg coefficient</b>	504	1627	3979	5837	11678	18199	25850
<b>Coefficient K1</b>	113,9	113,9	113,9	113,9	113,9	113,9	113,9

Tab. 4.17

#### 4.5 - POSSIBLE CONFIGURATIONS

The APERFLUX 851 equipment can have different configurations through the installation of the following accessories:

- DB/851 silencer
- PM/819 monitor
- SB/82 built-in slam-shut valve
- HB/97\* built-in slam-shut valve

\* available for nominal diameters DN 100, 150, 200, 250.

The possible configurations are summarised as follows:

APERFLUX 851	Silencer DB/851	Monitor PM/819	Slam-shut valve SB/82 built-in slam- shut valve	Slam-shut valve HB/97 built-in slam- shut valve
<b>DB/851 silencer</b>	-	Yes	Yes	Yes
<b>PM/819 monitor</b>	Yes	-	No	No
<b>Slam-shut valve SB/82</b>	Yes	No	-	No
<b>Slam-shut valve HB/97</b>	Yes	No	No	-

Tab. 4.18

The accessories can be installed directly at the factory or, at a later time, directly on site.

#### NOTICE!

**The installation of accessories is described in the relevant chapter of this manual.**

### 4.5.1 - BUILT-IN SILENCER

The DB/851 silencer (1) is incorporated between the header (2) and the main body of the equipment (3).

The DB/851 silencer reduces the noise generated by the equipment during the lamination process. Noise is absorbed precisely where it is generated, which prevents it from propagating.

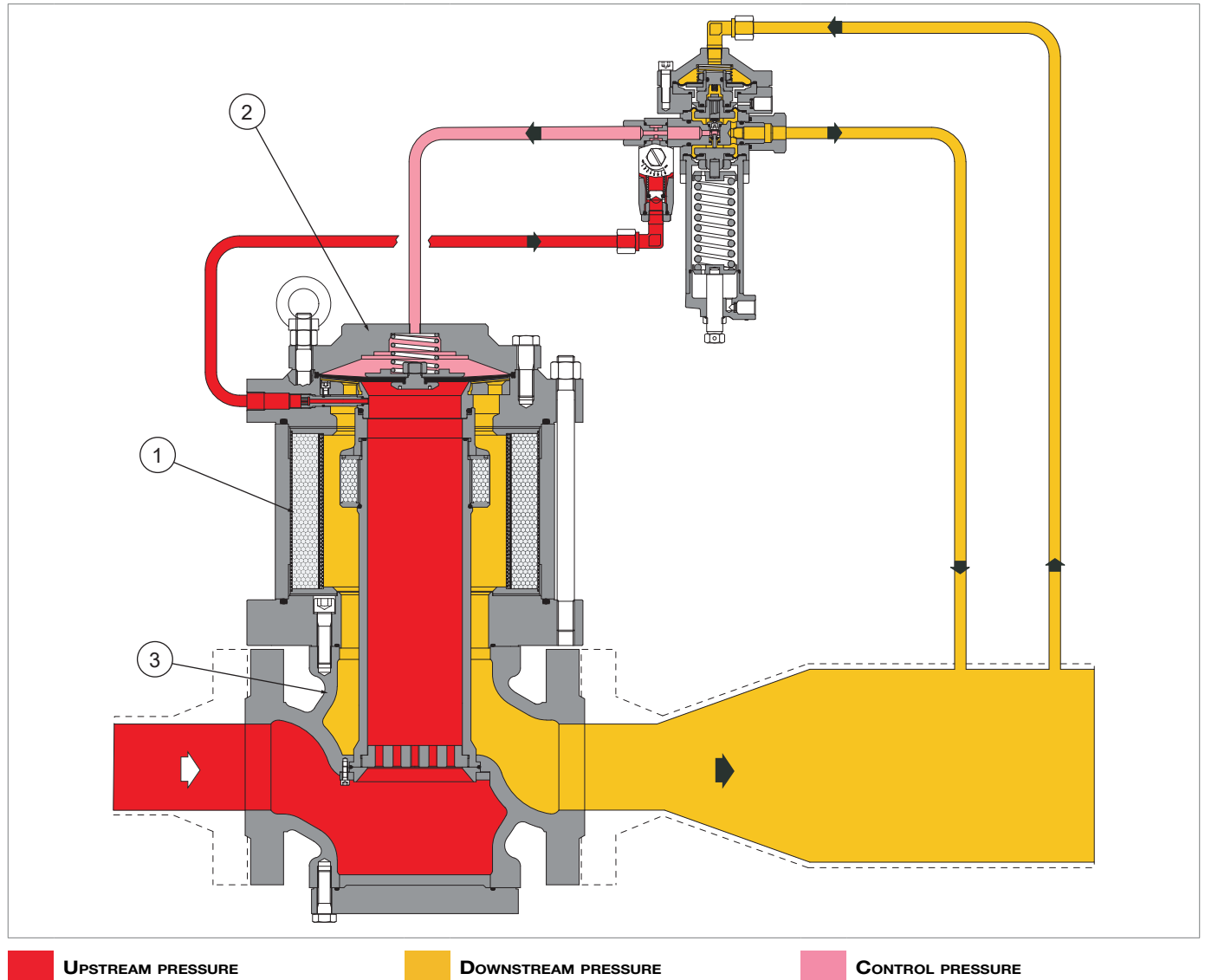

Fig. 4.3. Incorporated DB/851 silencer

**4.5.2 - MONITOR**

The PM/819 monitor (1) is normally installed upstream of the main pressure regulator (2) in a fully open position during normal operation.

The PM/819 monitor is used to keep the pressure value downstream of the main regulator within the preset limits in case of failure.

The PM/819 monitor can be:

- incorporated in the regulator (2);
- installed in line with the regulator (2).

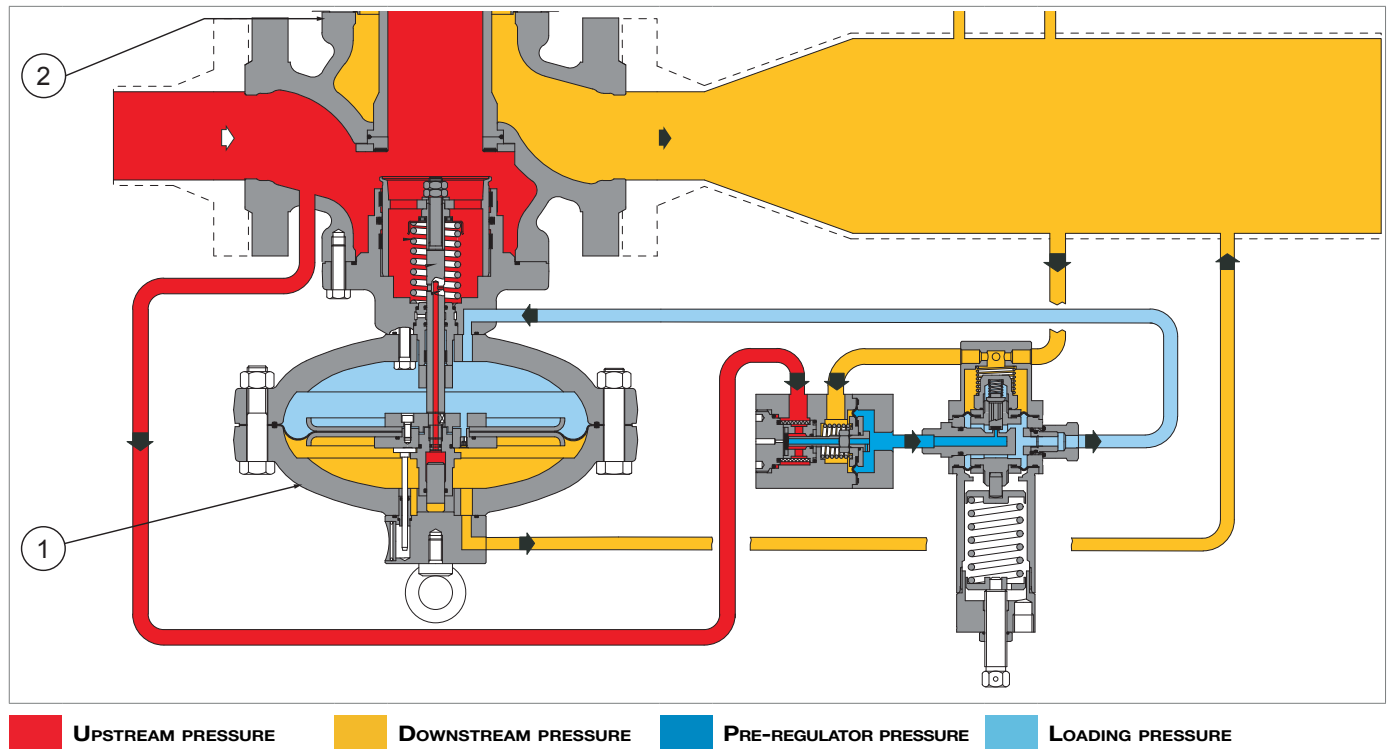

Fig. 4.4. APERFLUX 851 with PM/819 monitor

#### 4.5.2.1 - BUILT-IN MONITOR

The PM/819 monitor (1) is mounted directly on the service controller body (2), converting the equipment into two pressure regulators with a common valve body. The two regulators have the following characteristics:

- they are controlled by two distinct pilots and by independent servomotors;
- they work on independent valve seats.

#### BUILT-IN MONITOR OPERATION

##### NOTICE!

To check the position of the plug (3), look at the position of the stroke indicator rod (E) by referring to the slide (F) on the flange (G) of the monitor:

- open 100%;
- closed 0%.

In depressurised conditions, the plug (3) is kept in a closed position by the spring (4) and rests on the reinforced gasket (5).

The upstream pressure ( $P_u$ ), even if variable, does not change this position as the plug (3) is completely balanced, just like the stem (6), as a result of the upstream pressure ( $U_p$ ), through the hole (A), in the chamber (B).

The position of the plug (3) is controlled by the movements of the diaphragm (7) that the following act on:

- towards the closed position: the load of the spring (4) and the thrust resulting from the downstream pressure ( $P_d$ ) in the chamber (C),
- towards the open position: the thrust resulting from the loading pressure ( $P_m$ ) in the chamber (D), supplied by the pilot (8).

The weight of the mobile unit acts towards the shut-off or open position depending on the installation position of the regulator (2).

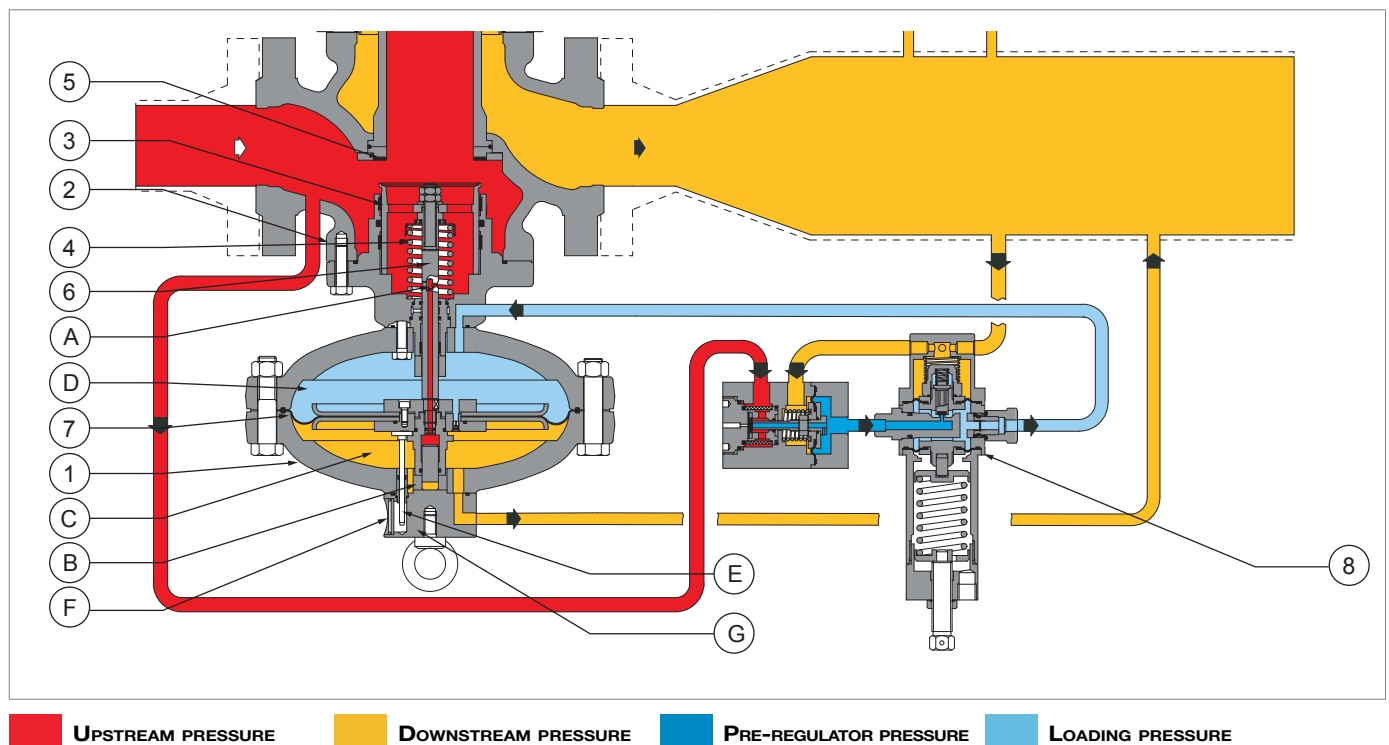

Fig. 4.5. Incorporated monitor operation

**OPERATION OF THE BUILT-IN MONITOR IN STAND-BY CONDITIONS:**

The PM/819 built-in monitor (1) is normally open during standard operation as pilot (2) calibration is higher than that of the main regulator (4) pilot.

The passage of the pre-regulator pressure (Pep) generated by the R14/A pre-regulator (5) through the fully open pilot (2) also keeps the built-in monitor PM/819 (1) fully open.

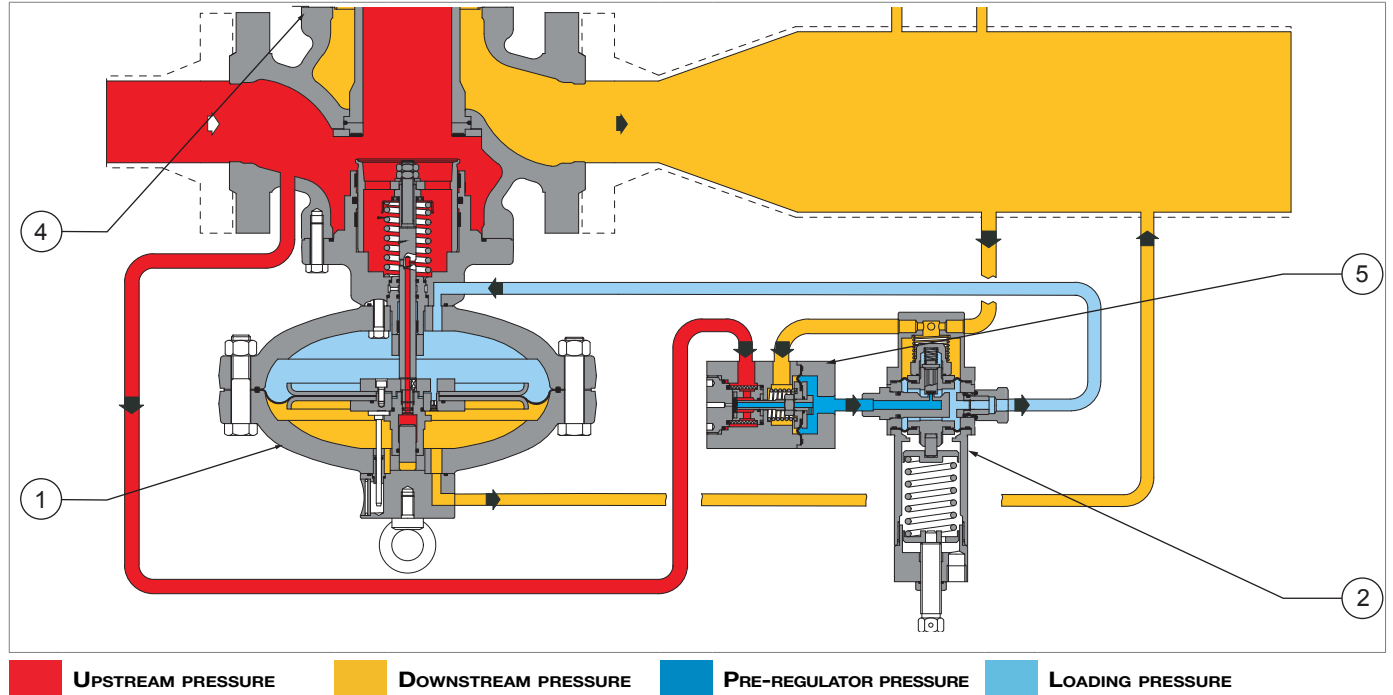

Fig. 4.6. Operation of the built-in monitor in stand-by conditions

### BUILT-IN MONITOR OPERATION IN THE EVENT OF FAILURE OF THE MAIN REGULATOR:

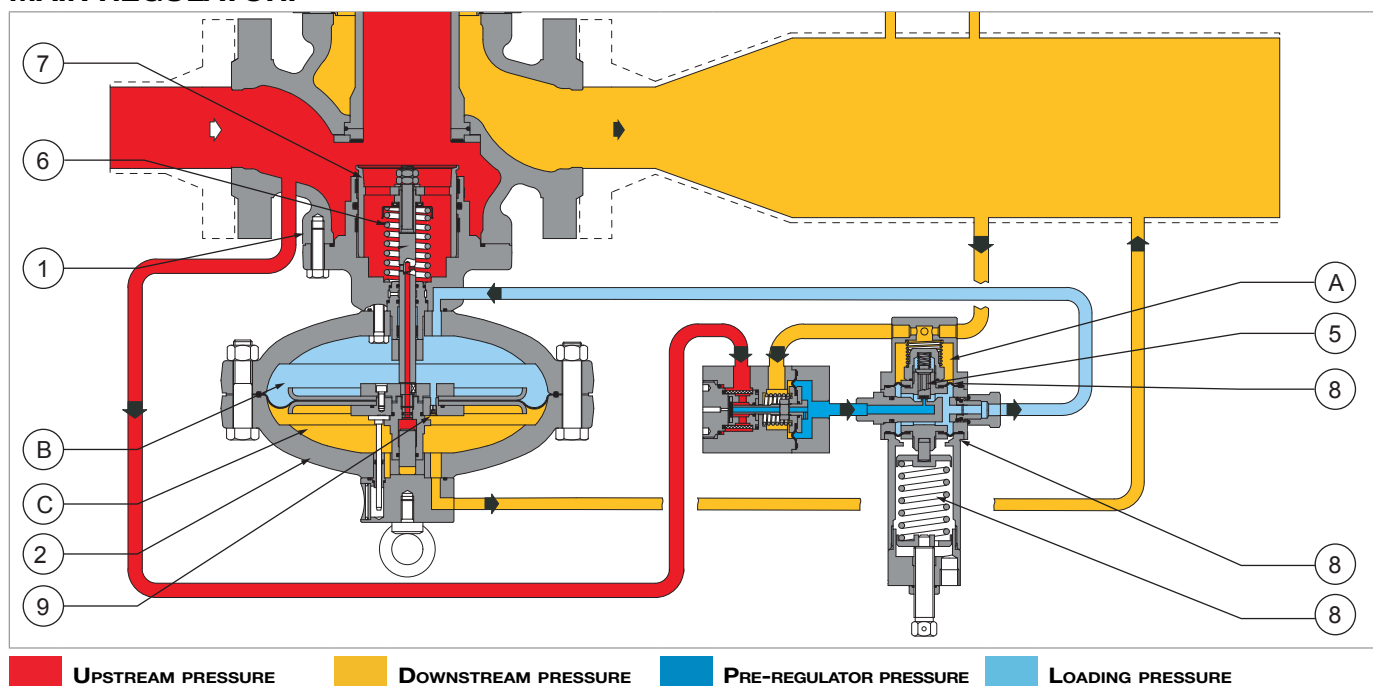

Fig. 4.7. Built-in monitor operation in the event of failure of the main regulator

Should the main regulator (1) fail, the PM/819 monitor (2) will trip until balanced adjustment is achieved. Therefore, should the following occur during operation:

Operating conditions	Operating consequences	Outcome
<b>Decrease in downstream pressure (Pd) due to:</b> <ul style="list-style-type: none"> <li>• rise in the requested flow rate;</li> <li>• or decrease in upstream pressure (Up).</li> </ul>	Imbalance between the pressure force in the chamber (A) and the calibration spring (3) of the pilot (4) which causes: <ul style="list-style-type: none"> <li>• increased opening of the pilot (4) plug (5);</li> <li>• consequent increase in the value of the loading pressure (Pm), inside the chamber (B).</li> </ul>	Opening of the main regulator (1) plug (7) until forces between the downstream pressure (Pd) in the chamber (A) and the pilot (4) calibration spring (3) have been balanced again.
<b>Increase in downstream pressure (Pd) with the pilot (4) plug (5) being moved to the shut-off position.</b>	Moving the main regulator (1) plug (7) to the shut-off position due to: <ul style="list-style-type: none"> <li>• the decrease in the load pressure (Pm) due to the transfer of this pressure between the chambers (B) and (C) of the regulator (1) through the orifice (9)</li> <li>• force applied by the spring (6).</li> </ul>	Return of the downstream pressure (Pd) to the predetermined value and to the balance of forces between the downstream pressure (Pd) in the chamber (A) and the calibration spring (3) of the pilot (4).

Tab. 4.19

#### 4.5.2.2 - M/A THROTTLE

##### NOTICE!

**For the monitor to be used as a safety accessory according to "PED" Directive 2014/68/EU, installing the M/A throttle is recommended.**

In the event of faults with the main regulator (1), the M/A throttle (3) is installed to speed up the intervention of the built-in PM/819 monitor (2).

The M/A throttle (3), depending on a downstream pressure signal ( $P_d$ ), discharges the gas enclosed in the monitor's drive chamber into the atmosphere, thus enabling faster intervention.

M/A throttle calibration:

- must be higher than the shut-off pressure of the monitor (2) with reference to the specific SG value;
- is carried out by turning the adjusting screw (4) clockwise or anti-clockwise to increase or decrease its value.

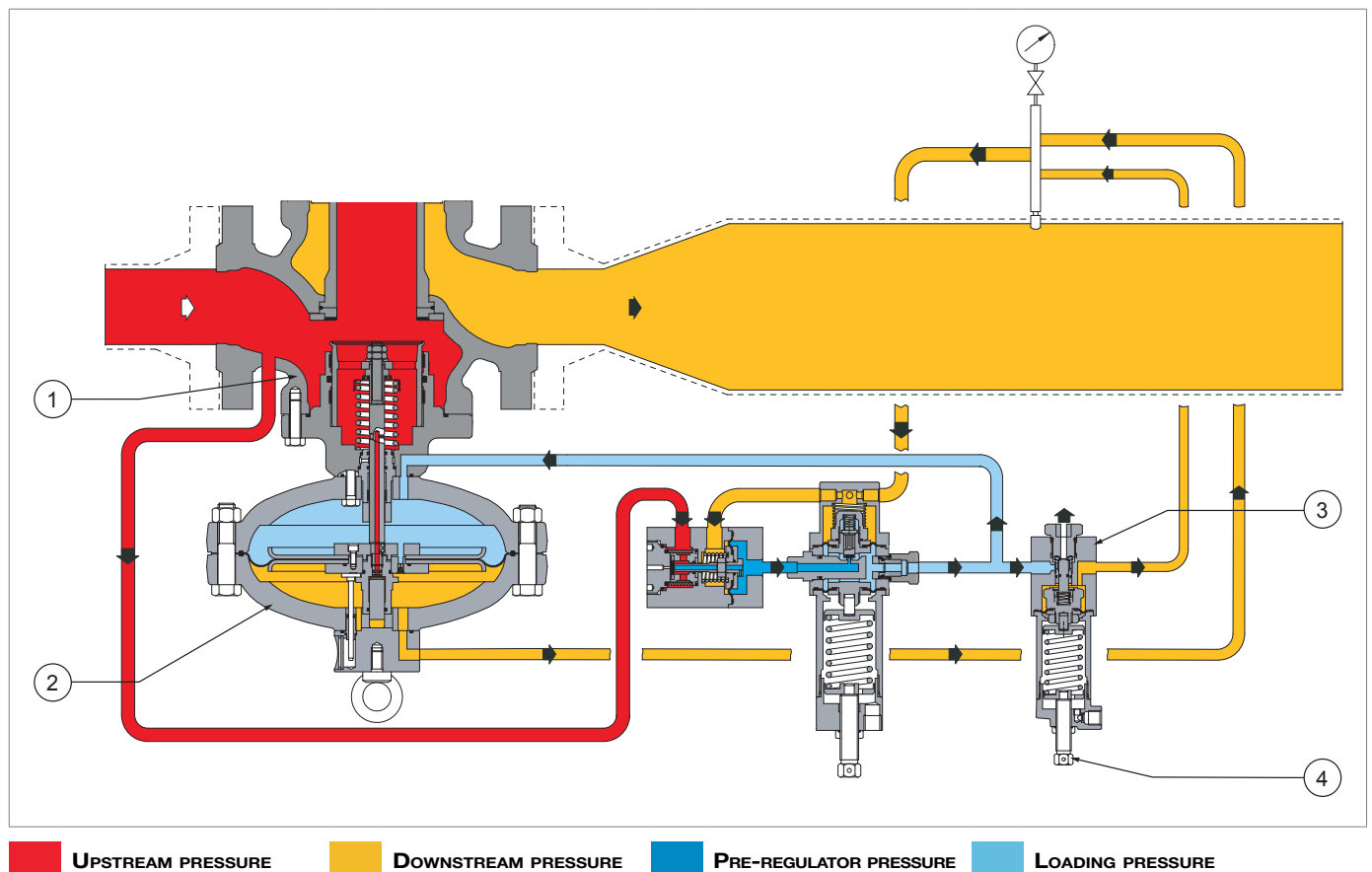

Fig. 4.8. Accelerator valve

### 4.5.3 - SLAM-SHUT VALVE

The slam-shut valve is a safety device is used to shut off the gas flow if the pressure value at the control point exceeds the calibration value of the valve itself.

The slam-shut valve is incorporated into the main body of the equipment and consists of:

- a control system;
- the slam-shut device mechanism.

In the event of triggering, the slam-shut valve shuts off power supply to the regulator and its control pilot.

#### 4.5.3.1 - INCORPORATED SB/82 SLAM-SHUT VALVE

The SB/82 built-in slam-shut valve can be operated:

- by the pressure switch;
- manually;
- with remote control.

The main features of the SB/82 built-in slam-shut valve are:

- tripping due to downstream pressure increase and/or decrease;
- design pressure: 100 bar for all accessory components;
- local shut-off button;
- precision (AG)
  - » 1 on the intervention value for maximum pressure;
  - » 5 on the intervention value for minimum pressure;
- manual reset only with internal bypass activated by the reset lever.

The incorporated slam-shut valve SB8/2 consists of:

Pos.	Description
1	Plug
2	Control pressure switch
3	Reset system (manually operated through a lever)

Tab. 4.20

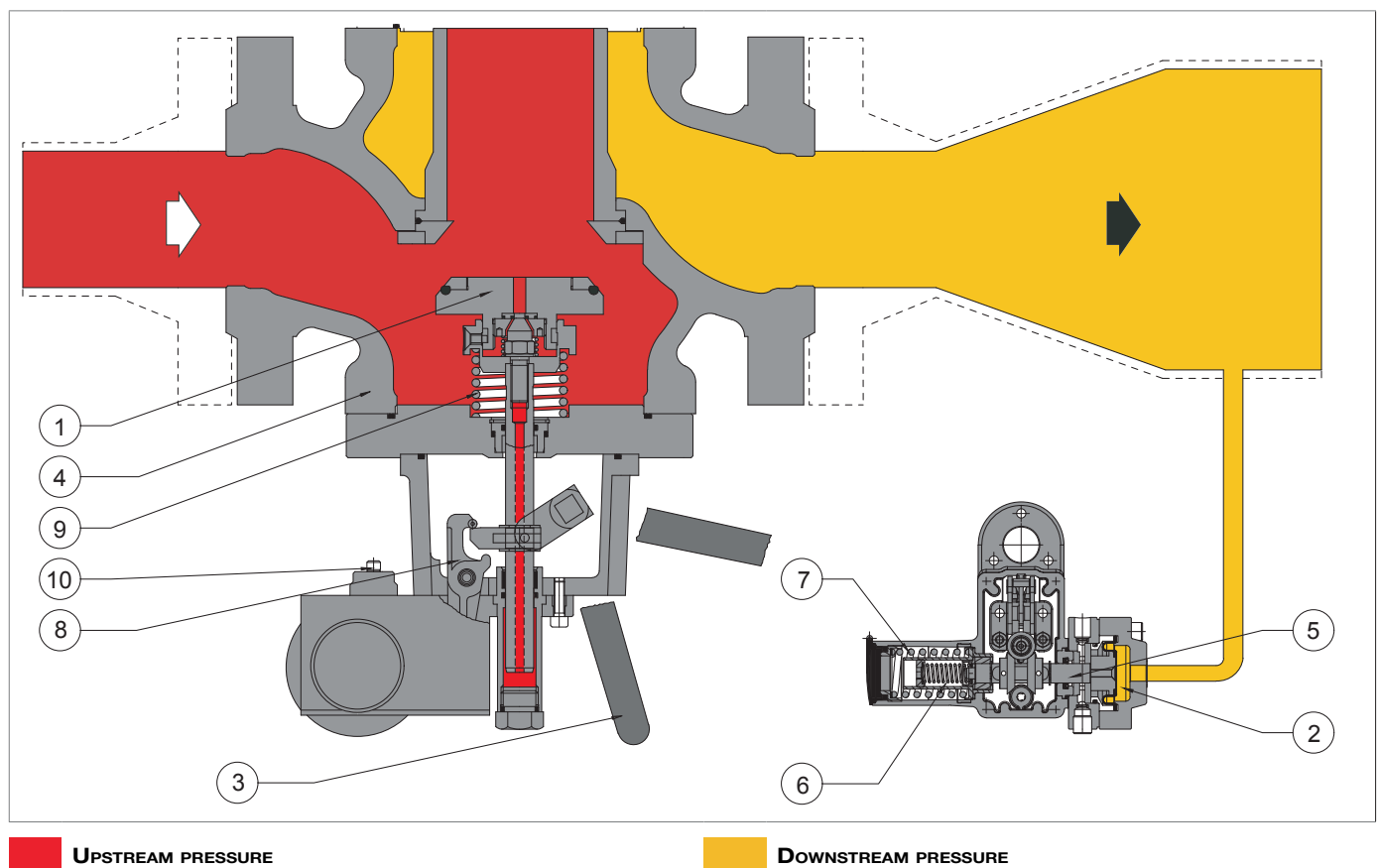

Fig. 4.9. APERFLUX 851 with SB/82 incorporated slam-shut valve

**OPERATION:**

The tripping pressure acts on the control element of the control pressure switch (2), which is solidly connected to the stem (5), and receives an antagonistic force through the springs due to maximum (7) and minimum (6) pressure tripping, calibrated to the pre-set values.

The translation of the stem (5) causes the control device (8) of the mobile system to be released and, through the action of the spring (9), the plug (1) to be shut off. To reset the device, it is necessary to act on the lever (3) which:

- opens an internal bypass in the first section of the stroke allowing the upstream pressure to be transferred from the inlet chamber to the outlet chamber of the regulator body (4), thereby rebalancing the pressure on the plug (1);
- re-couples the control device (8) of the mobile system.

 **NOTICE!**

**The release of the control device (8) of the mobile system can also be controlled manually by means of a button (10).**

#### 4.5.3.2 - HB/97 BUILT-IN SLAM-SHUT VALVE

The built-in HB/97 incorporated slam-shut valve can be operated:

- by the pressure switch;
- manually;
- with remote control.

The main features of the HB/97 built-in slam-shut valve are:

- balanced valve plug;
- self-powered indirect pneumatic drive
- local shut-off button;
- tripping due to downstream pressure increase and/or decrease;
- precision (AG)
  - » 1 on the intervention value for maximum pressure;
  - » 5 on the intervention value for minimum pressure;
- built-in bypass;
- manual resetting only.

The incorporated slam-shut valve HB/97 consists of:

Pos.	Description
1	Balanced valve plug
2	Single-acting pneumatic actuator
3	LINE OFF 2.0 device

Tab. 4.21

The LINE OFF 2.0 device (3) consists of:

Pos.	Description
4	HP2/2: gas filtering device before entering the circuit with bypass function required for resetting the built-in HB/97 slam shut.
5	AR100: flow throttle valve to adjust the pressure loading speed in the pneumatic circuit and to filter the gas entering the R44/SS regulator ( <b>Pos. 6</b> ).
	<div style="border: 1px solid black; padding: 5px;"> <p><b>! NOTICE!</b></p> <p><b>The setting of the pressure loading speed in the pneumatic circuit is regulated by a screw (minimum value 1, maximum value 8).</b></p> </div>
6	R44/SS: pressure regulator necessary to decrease the upstream pressure of the regulator to the loading pressure of the HB/97 incorporated slam-shut valve cylinder.
7	VS/FI: safety valve used to: <ul style="list-style-type: none"> <li>• discharge any overpressure generated by malfunction of the R44/SS pressure regulator into the atmosphere;</li> <li>• protect the entire circuit downstream of the R44/SS pressure regulator.</li> </ul>
8	3/2 valve used to pressurise and depressurise the cylinder of the HB/97 incorporated slam-shut valve.
9	Control pressure switch. through the head of the control pressure switch connected downstream, it is used to trip the HB/97 built-in slam-shut valve due to decreases or increases in downstream pressure.

Tab. 4.22

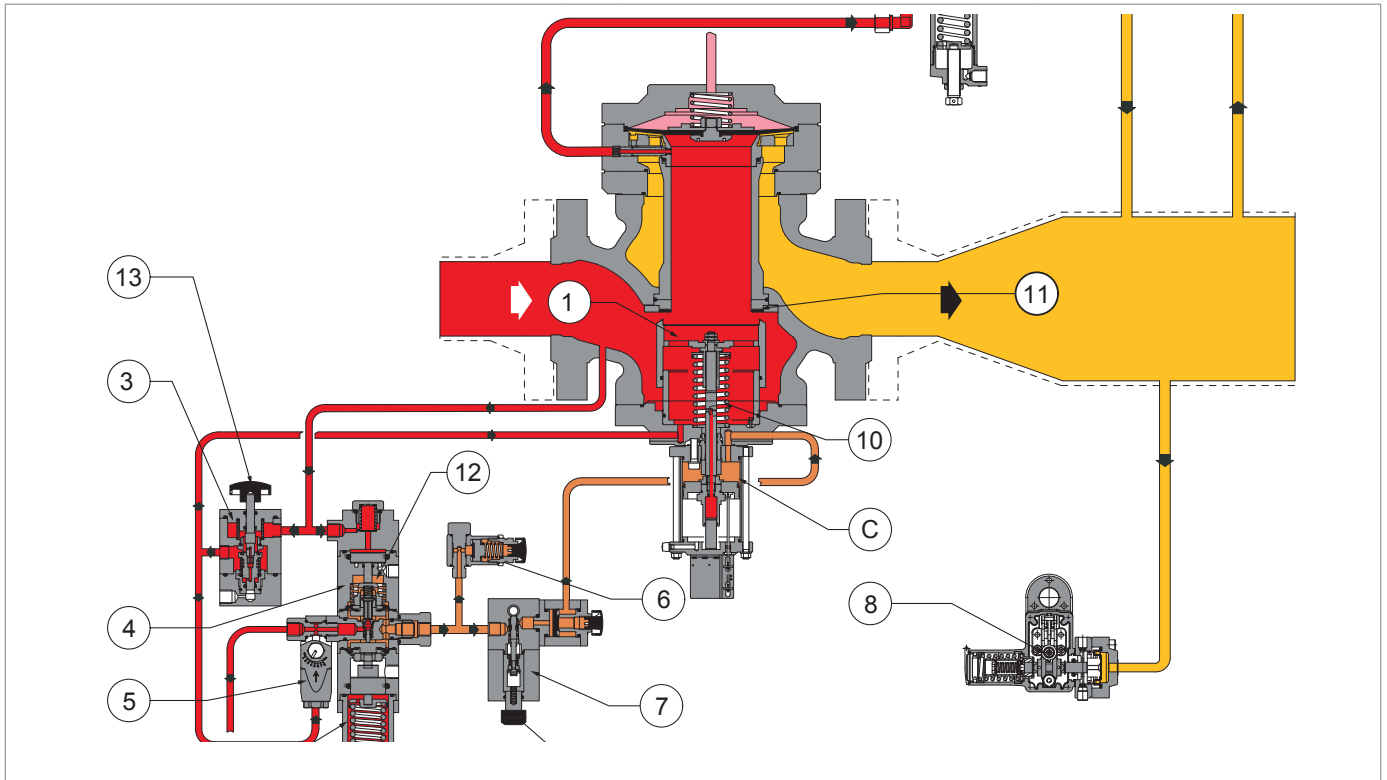

■ **UPSTREAM PRESSURE**   
 ■ **DOWNSTREAM PRESSURE**   
 ■ **ACTUATOR SUPPLY PRESSURE**   
 ■ **CONTROL PRESSURE**

Fig. 4.10. APERFLUX 851 with HB/97 incorporated slam-shut valve

### OPERATION:

At no pressure, the valve plug (1) is kept in the shut-off position by the spring (10) and rests on the reinforced gasket (11).

The upstream pressure ( $P_u$ ) reaches the HP2/2 bypass device (4) and the upper head (12) of the R44/SS regulator (6) to prevent inappropriate resetting of the valve. By adjusting the activation button (13) of the bypass, the pressurised gas is filtered and feeds the AR100 throttle valve (5), which in turn supplies:

- the chamber of the adjustment spring (14);
- the upstream of R44/SS regulator (6), calibrated at a pressure of 4.5 bar to overcome the force of the shut-off spring (15) of the main valve.

Pressing the reset lever (16) acts on the pressure switch coupling system (9), so as to allow, through the 3/2 valve (8):

- pressurization of the actuator (2) of the slam shut valve by the R44/SS regulator (6);
- the plug opening (1).

In the event that the downstream pressure ( $P_d$ ) increases or decreases, the pressure switch coupling (9) moves to:

- discharge the pressure from the actuator (2) into the atmosphere through the 3/2 valve (8);
- allow the spring (10) to bring the plug (1) to the shut-off position.

#### 4.5.4 - SLAM-SHUT VALVE PRESSURE SWITCHES

The pressure switch is a control device consisting of:

Pos.	Description
1	Control element. <b>! NOTICE!</b> <b>The control element can be a diaphragm or a piston.</b>
2	Stem.
3-4	Adjustment feeler gauges.
5	Spring for maximum pressure tripping.
6	Spring for minimum pressure tripping.
7	OPSO maximum spring adjustment nuts (5).
8	UPSO minimum spring adjustment nuts (6).
10	Manual release button.

Tab. 4.23

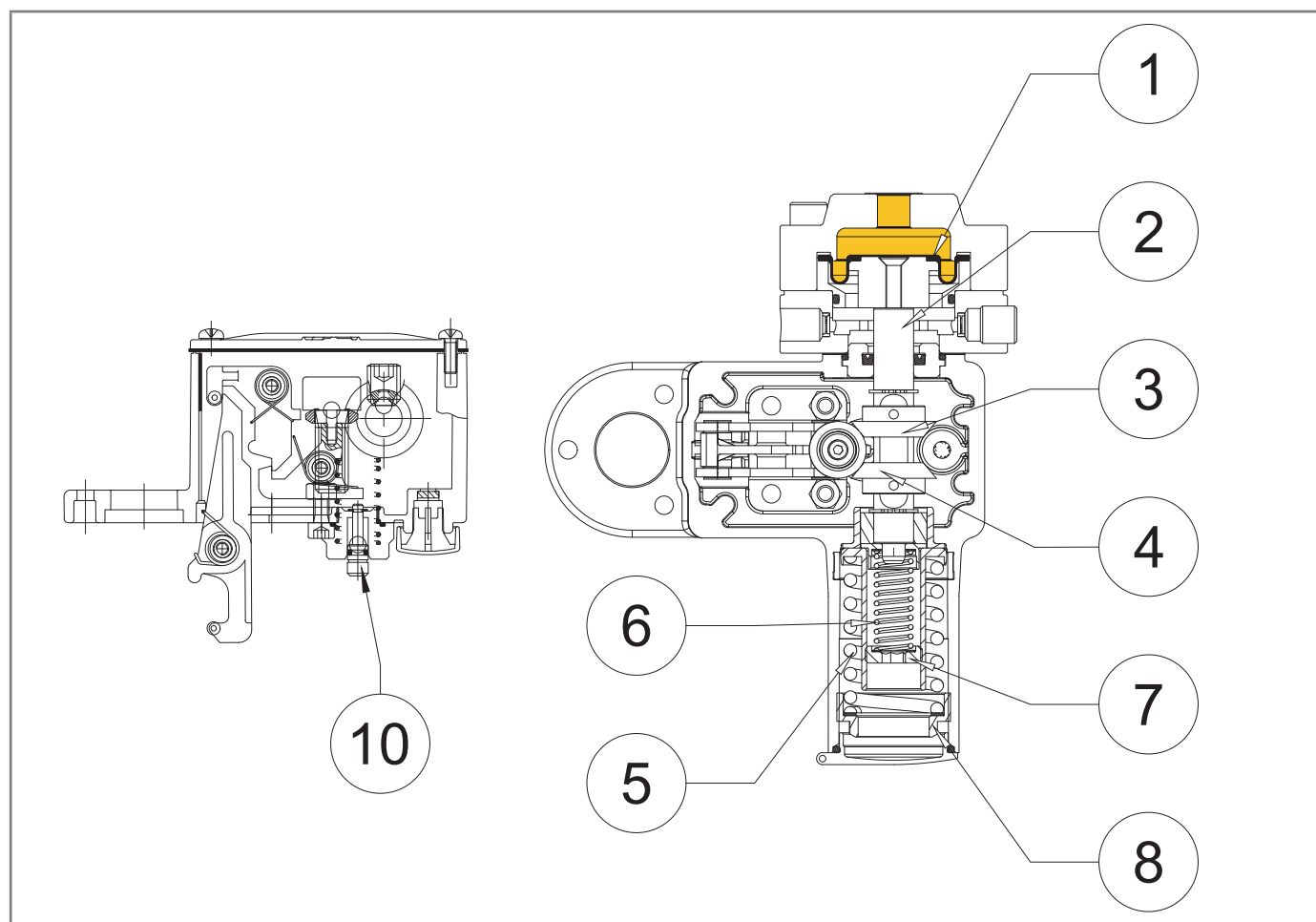

Fig. 4.11.

Slam-shut device pressure switch

We list the models of possible pressure switches for this regulator:

<b>Model pressure switch</b>	<b>Max [bar]</b>	<b>Min [bar]</b>
<b>102M</b>	0.2 - 5.5	0.05 - 2.8
<b>102MH</b>	0.2 - 5.5	2.8 - 5.5
<b>103M</b>	2 - 22	0.2 - 8
<b>103MH</b>	2 - 22	8 - 19
<b>104M</b>	15 - 45	1.6 - 18
<b>104MH</b>	15 - 45	18 - 41
<b>105M</b>	30 - 90	3 - 44
<b>105MH</b>	30 - 90	44 - 90

*Tab. 4.24*

PAGE INTENTIONALLY LEFT BLANK

## 5 - TRANSPORT AND HANDLING

### 5.1 - SPECIFIC WARNINGS FOR TRANSPORT AND HANDLING

#### NOTICE!

Transport and handling must be carried out by personnel:

- qualified (specially trained);
- who are familiar with accident prevention and workplace safety regulations;
- authorised to use lifting equipment and means;
- in compliance with the regulations in force in the country of destination of the equipment.

#### Transport with forklift or crane

<b>Operator qualification</b>	Person in charge of transport, handling, unloading and placing on site
<b>PPE required</b>	 <p><b>WARNING!</b></p> <p>The PPE listed in this table is related to the risk associated with the equipment. For the required PPE to protect against risks associated with the workplace, installation or operating conditions, please refer to:</p> <ul style="list-style-type: none"> <li>• the regulations in force in the country of installation;</li> <li>• <u>any information provided by the Safety Manager at the installation facility.</u></li> </ul>
<b>Means of lifting</b>	Hoist crane, forklift truck or other suitable equipment.
<b>Weights and dimensions of the equipment</b>	For dimensions and weights please refer to “5.2 - Physical characteristics of the equipment”.

Tab. 5.25

### 5.1.1 - PACKAGING AND FASTENERS USED FOR TRANSPORT

The transport packaging has been designed and manufactured to avoid damage during normal transport, storage and handling.

The equipment and spare parts must be kept in their packaging until they are installed.



Upon receiving the equipment:

- make sure that no part of the packaging has been damaged during transport and/or handling;
- immediately report any damage found to PIETRO FIORENTINI S.p.A..

**! NOTICE!**

**PIETRO FIORENTINI S.p.A. shall not be liable for any damage to people or property caused by accidents due to failure to comply with the instructions provided in this manual.**

We list the types of packaging used:

Ref.	Type of packaging	Image
A	Cardboard box	
B	Wooden box	
C	Pallet	

Tab. 5.26

PAGE INTENTIONALLY LEFT BLANK

## 5.2 - PHYSICAL CHARACTERISTICS OF THE EQUIPMENT

### 5.2.1 - APERFLUX 851

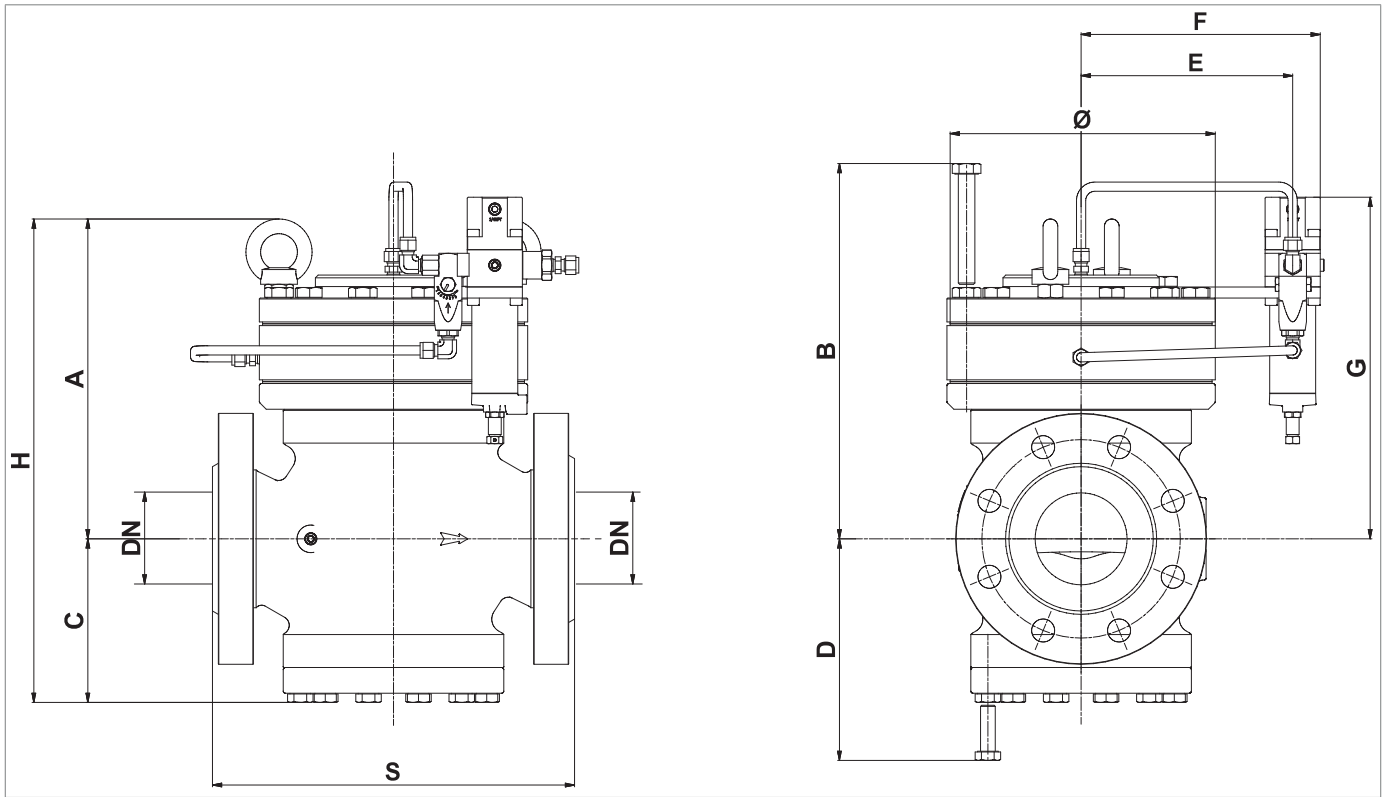

Fig. 5.12. Physical characteristics APERFLUX 851

#### Overall dimensions APERFLUX 851

Nominal diameter [mm]	25	50	80	100	150	200	250
Size [inches]	1"	2"	3"	4"	6"	8"	10"
<b>S - Ansi 150/PN 16</b>	184	254	298	352	451	543	673
<b>S - Ansi 300</b>	197	267	317	368	473	568	708
<b>S - Ansi 600</b>	210	286	336	394	508	609	752
<b>Ø</b>	125	160	245	290	385	490	615
<b>A</b>	200	230	300	340	420	455	580
<b>B</b>	230	260	340	380	470	510	520
<b>C</b>	100	130	150	190	240	265	340
<b>D</b>	130	160	200	250	300	320	440
<b>E</b>	140	145	190	210	260	315	370
<b>F</b>	160	175	220	240	290	345	415
<b>G</b>	260	280	350	380	450	490	380
<b>H</b>	300	360	450	530	660	720	920
<b>Pneumatic piping connections</b>	Øe 10mm x Øi 8mm						

Tab. 5.27

<b>Weights [kgf]</b>							
<b>Ansi 150/PN 16</b>	20	35	76	115	235	335	700
<b>Ansi 300</b>	21	36	82	128	257	395	750
<b>Ansi 600</b>	22	38	85	138	290	435	850

Tab. 5.28

**5.2.2 - APERFLUX 851 + DB/851**

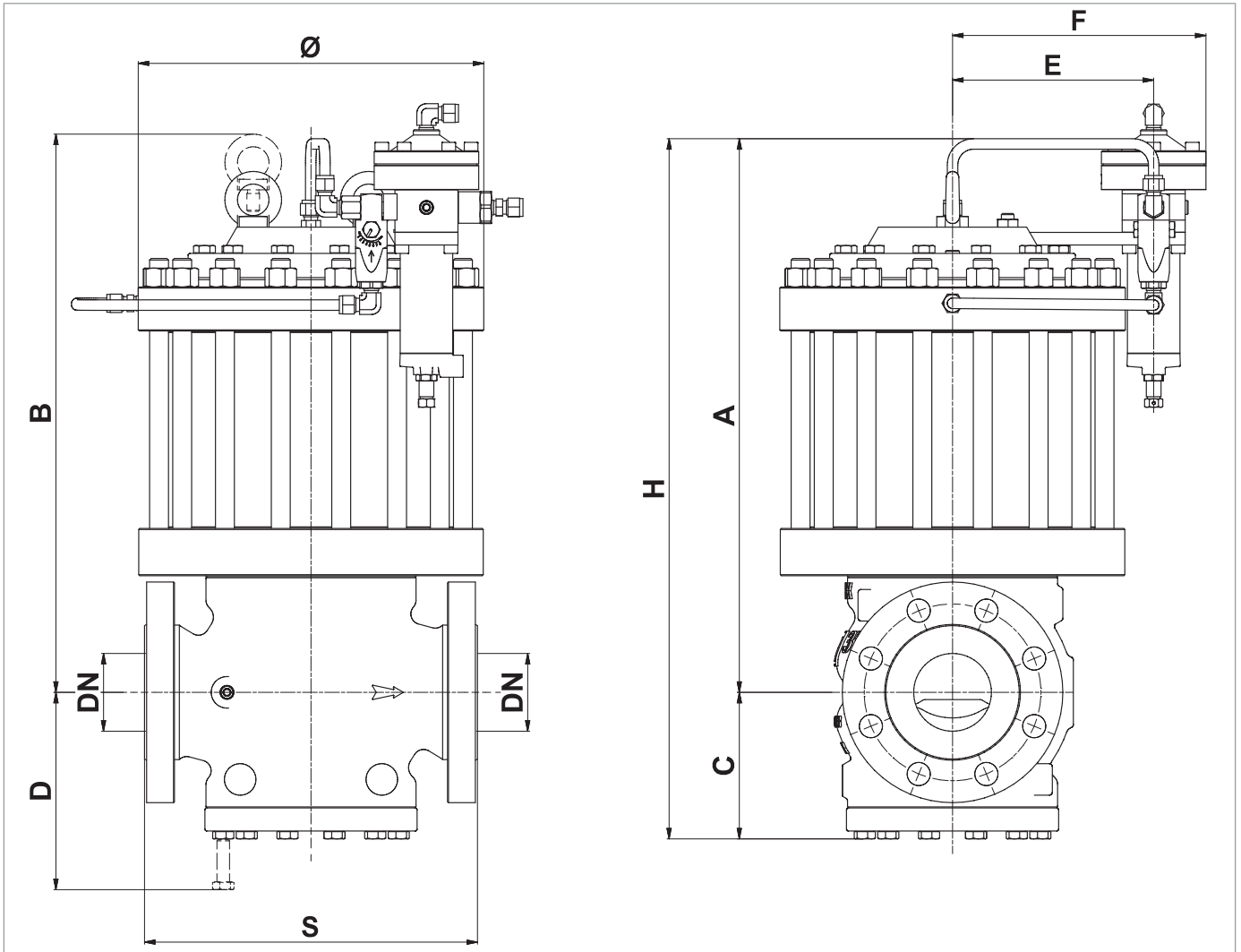

Fig. 5.13. APERFLUX 851 + DB/851 physical characteristics

**APERFLUX 851 + DB/851 overall dimensions**

<b>Nominal diameter [mm]</b>	25	50	80	100	150	200	250
<b>Size [inches]</b>	1"	2"	3"	4"	6"	8"	10"
<b>S - Ansi 150/PN 16</b>	184	254	298	352	451	543	673
<b>S - Ansi 300</b>	197	267	317	368	473	568	708
<b>S - Ansi 600</b>	210	286	336	394	508	609	752
<b>Ø</b>	220	300	330	390	480	645	740
<b>A</b>	355	420	500	570	715	910	1025
<b>B</b>	465	530	625	695	850	1045	1085
<b>C</b>	100	130	150	190	240	265	340
<b>D</b>	130	160	200	250	300	320	440
<b>E</b>	162	196	216	241	234	237	262
<b>F</b>	192	226	246	271	264	267	292
<b>G</b>	370	440	525	595	745	950	1396
<b>H</b>	455	550	650	790	980	1175	1215
<b>L</b>	560	673	792	897	1081	1332	1372
<b>Pneumatic piping connections</b>	Øe 10mm x Øi 8mm						

*Tab. 5.29*
**Weights [kgf]**

<b>Ansi 150/PN 16</b>	47	100	168	240	391	760	1240
<b>Ansi 300</b>	49	102	177	268	433	834	1292
<b>Ansi 600</b>	50	104	180	278	466	874	1392

*Tab. 5.30*

**5.2.3 - APERFLUX 851 + PM/819**

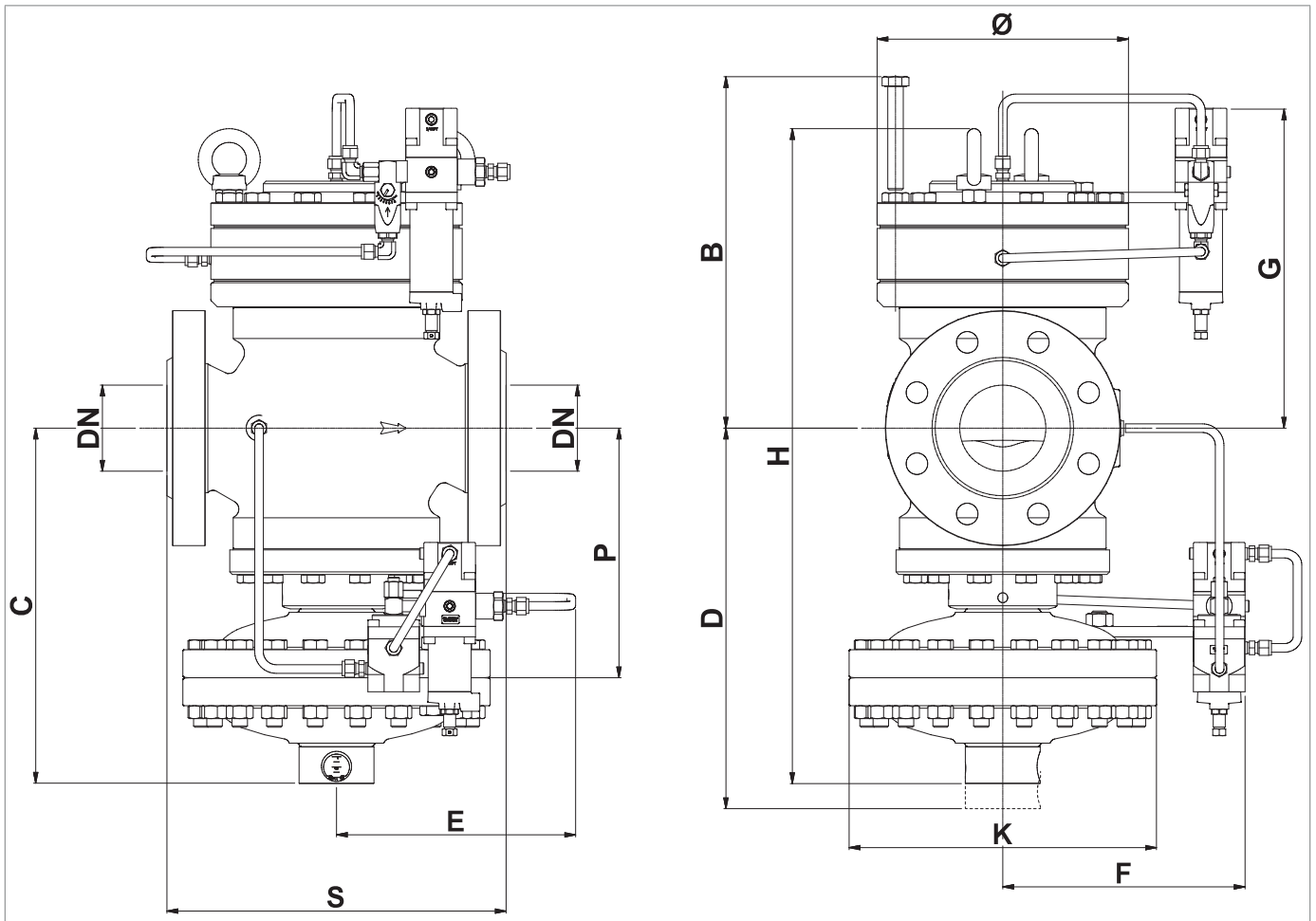

Fig. 5.14. APERFLUX 851 + PM/819 physical characteristics

**APERFLUX 851 + PM/819 overall dimensions**

<b>Nominal diameter [mm]</b>	25	50	80	100	150	200	250
<b>Size [inches]</b>	1"	2"	3"	4"	6"	8"	10"
<b>S - Ansi 150/PN 16</b>	184	254	298	352	451	543	673
<b>S - Ansi 300</b>	197	267	317	368	473	568	708
<b>S - Ansi 600</b>	210	286	336	394	508	609	752
<b>Ø</b>	125	160	245	290	385	490	615
<b>B</b>	230	260	340	380	470	510	520
<b>C</b>	320	350	430	490	650	750	680
<b>D</b>	410	430	370	600	735	850	900
<b>E</b>	370	370	410	410	485	485	370
<b>F</b>	270	270	310	310	385	385	415
<b>G</b>	260	280	350	380	450	490	380
<b>H</b>	520	580	730	830	1070	1205	1380
<b>K</b>	278	278	360	360	510	510	610
<b>P</b>	170	200	260	290	320	370	500
<b>Pneumatic piping connections</b>	Øe 10mm x Øi 8mm						

*Tab. 5.31*
**Weights [kgf]**

<b>Ansi 150/PN 16</b>	33	68	135	160	370	525	1100
<b>Ansi 300</b>	34	70	138	165	390	585	1150
<b>Ansi 600</b>	35	72	148	190	420	625	1250

*Tab. 5.32*

5.2.4 - APERFLUX 851 + SB/82 OR + HB/97

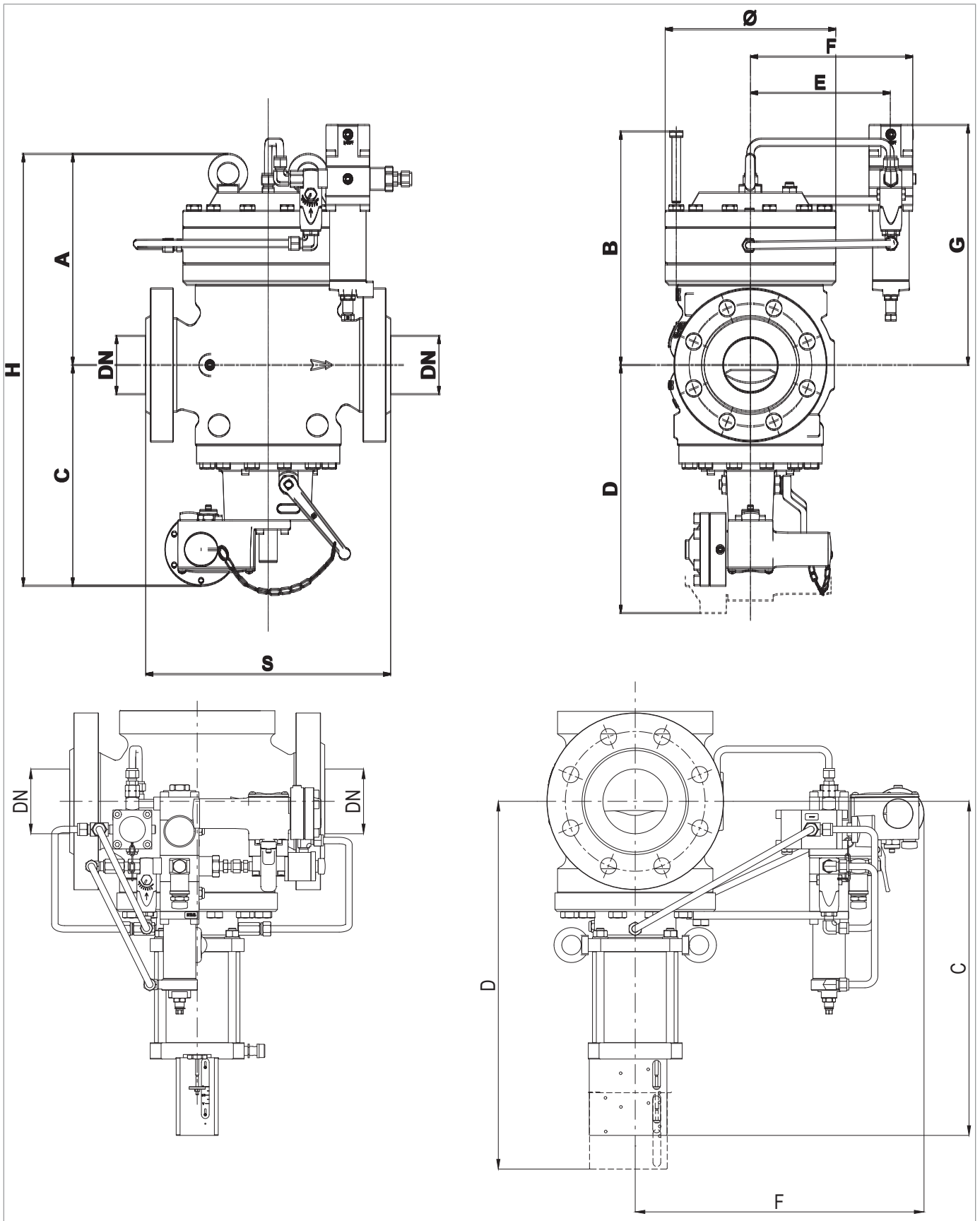

Fig. 5.15. Physical characteristics APERFLUX 851 + SB/82 OR + HB/97

**Overall dimensions APERFLUX 851 + SB/82 OR + HB/97**

Nominal diameter [mm]	25	50	80	100	150	200	250
Size [inches]	1"	2"	3"	4"	6"	8"	10"
<b>S - Ansi 150/PN 16</b>	184	254	298	352	451	543	673
<b>S - Ansi 300</b>	197	267	317	368	473	568	708
<b>S - Ansi 600</b>	210	286	336	394	508	609	752
<b>Ø</b>	125	160	245	290	385	490	615
<b>A</b>	200	230	300	340	420	455	580
<b>B</b>	230	260	340	380	470	510	520
<b>C WITH SB/82</b>	260	265	295	325	400	450	680
<b>C WITH HB/97</b>	-	-	-	518	645	687	796
<b>C WITH SB/82</b>	320	370	420	480	600	665	900
<b>D WITH HB/97</b>	-	-	-	650	835	900	1060
<b>E</b>	140	145	190	210	260	315	370
<b>F WITH SB/82</b>	160	175	220	240	290	345	415
<b>F WITH HB/97</b>	-	-	-	358	410	445	510
<b>G</b>	260	280	350	380	450	490	380
<b>H WITH SB/82</b>	415	470	570	640	795	905	1260
<b>H WITH HB/97</b>	-	-	-	858	1065	1132	1376
<b>Pneumatic piping connections</b>	Øe 10mm x Øi 8mm						

*Tab. 5.33*
**Weights [kgf]**

<b>Ansi 150/PN 16</b>	27	44	86	130	260	400	750
<b>Ansi 300</b>	27	46	92	145	290	470	800
<b>Ansi 600</b>	30	48	96	155	320	510	900

*Tab. 5.34*

5.2.5 - APERFLUX 851 + DB/851 + PM/819

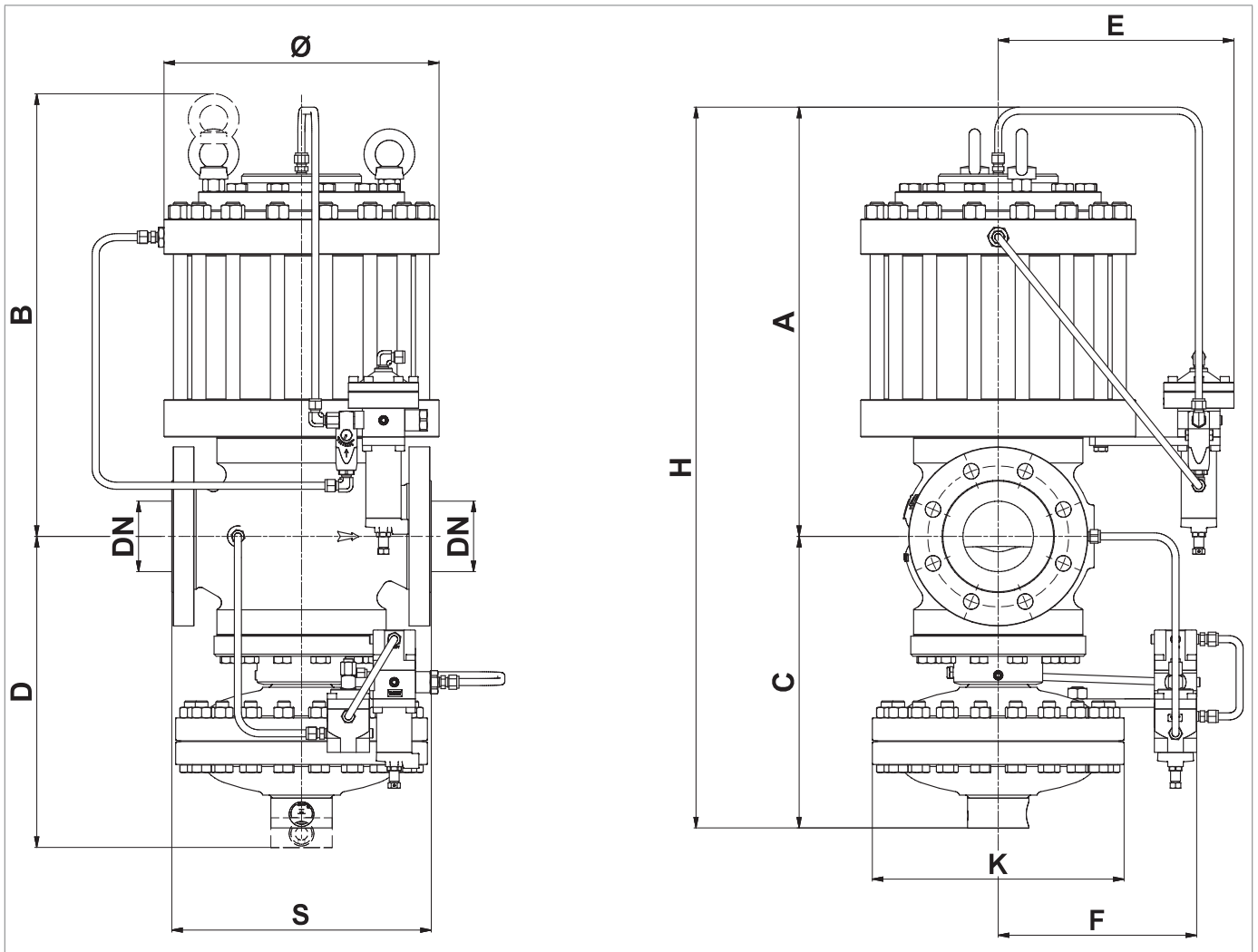

Fig. 5.16. APERFLUX 851 + DB/851 + PM/819 physical characteristics

**APERFLUX 851 + DB/851 + PM/819 overall dimensions**

<b>Nominal diameter [mm]</b>	25	50	80	100	150	200	250
<b>Size [inches]</b>	1"	2"	3"	4"	6"	8"	10"
<b>S - Ansi 150/PN 16</b>	184	254	298	352	451	543	673
<b>S - Ansi 300</b>	197	267	317	368	473	568	708
<b>S - Ansi 600</b>	210	286	336	394	508	609	752
<b>Ø</b>	220	300	330	390	480	645	740
<b>A</b>	335	420	500	570	715	910	1025
<b>B</b>	465	530	625	695	850	1045	1085
<b>C</b>	320	350	430	490	650	750	800
<b>D</b>	410	430	530	600	735	850	900
<b>E</b>	192	226	246	271	264	267	292
<b>F</b>	270	270	310	310	385	385	415
<b>G</b>	590	660	805	895	1155	1435	1856
<b>H</b>	685	750	905	995	1260	1530	1545
<b>I</b>	905	970	1185	1295	1670	2015	2005
<b>Pneumatic piping connections</b>	Øe 10mm x Øi 8mm						

*Tab. 5.35*
**Weights [kgf]**

<b>Ansi 150/PN 16</b>	60	133	223	295	526	950	1640
<b>Ansi 300</b>	62	135	232	325	568	1024	1692
<b>Ansi 600</b>	63	137	235	332	601	1064	1792

*Tab. 5.36*

5.2.6 - APERFLUX 851 + DB/851 + SB/82 OR + HB/97

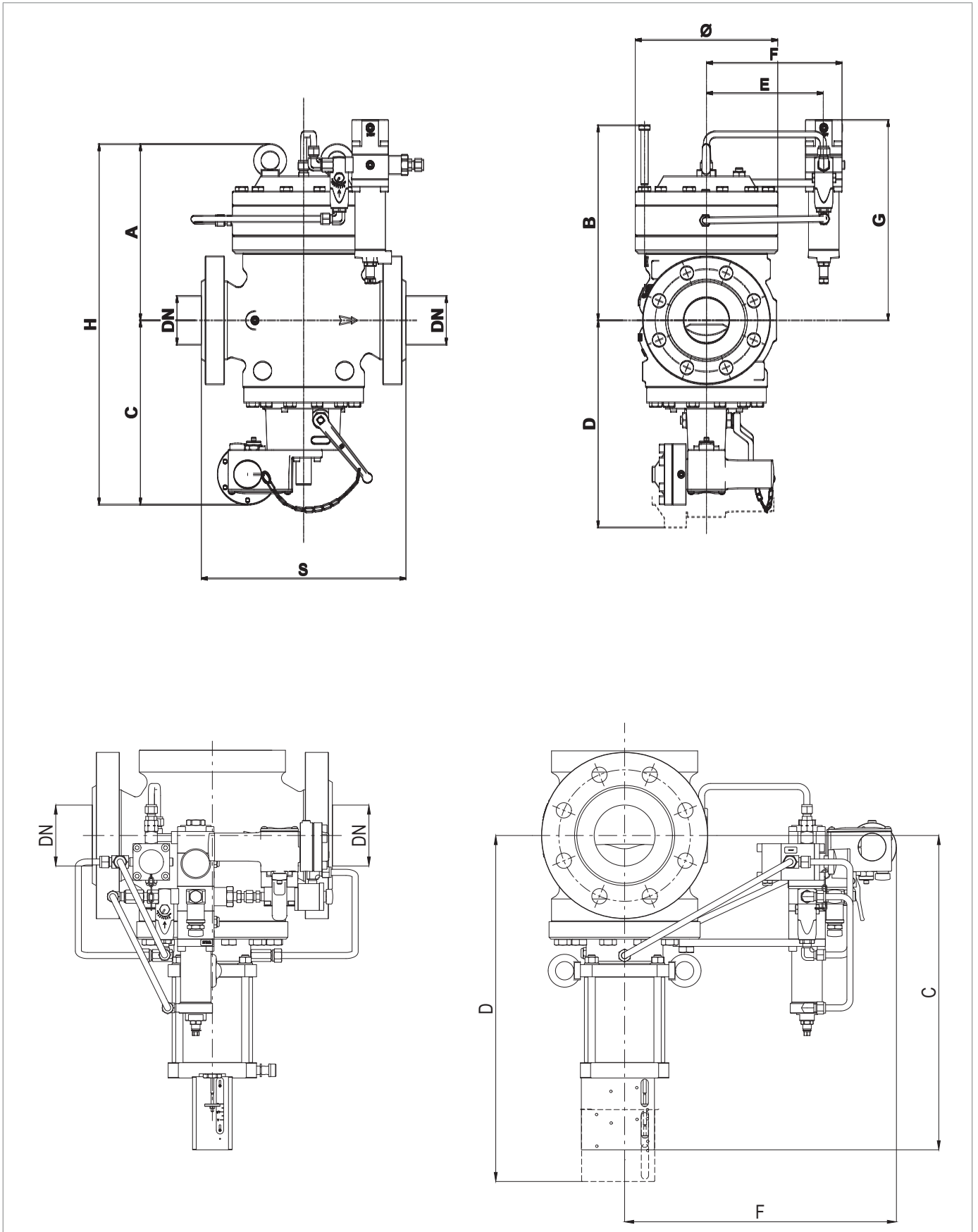

Fig. 5.17. Physical characteristics APERFLUX 851 + DB/82 + SB/82 OR + HB/97

**Overall dimensions APERFLUX 851 +DB/82 + SB/82 OR + HB/97**

<b>Nominal diameter [mm]</b>	25	50	80	100	150	200	250
<b>Size [inches]</b>	1"	2"	3"	4"	6"	8"	10"
<b>S - Ansi 150/PN 16</b>	184	254	298	352	451	543	673
<b>S - Ansi 300</b>	197	267	317	368	473	568	708
<b>S - Ansi 600</b>	210	286	336	394	508	609	752
<b>Ø</b>	220	300	330	390	480	645	740
<b>A</b>	335	420	500	570	715	910	1025
<b>B</b>	465	530	625	695	850	1045	1085
<b>C WITH SB/82</b>	260	265	295	325	400	450	680
<b>C WITH HB/97</b>	-	-	-	518	645	687	769
<b>C WITH SB/82</b>	320	370	420	480	600	665	900
<b>D WITH HB/97</b>	-	-	-	650	835	900	1060
<b>E</b>	192	226	246	271	264	267	292
<b>F WITH SB/82</b>	485	550	645	705	880	1135	1736
<b>F WITH HB/97</b>	-	-	-	358	410	445	510
<b>G</b>	570	660	770	870	1115	1360	1555
<b>H WITH SB/82</b>	675	783	912	1007	1216	1517	1712
<b>H WITH HB/97</b>	-	-	-	1088	1360	1597	1794
<b>Pneumatic piping connections</b>	Øe 10mm x Øi 8mm						

*Tab. 5.37*
**Weights [kgf]**

<b>Ansi 150/PN 16</b>	54	109	178	255	416	825	1290
<b>Ansi 300</b>	56	112	187	283	466	909	1342
<b>Ansi 600</b>	58	114	191	294	499	949	1442

*Tab. 5.38*

### 5.3 - EQUIPMENT ANCHORING AND LIFTING METHOD

 **HAZARD!**

Before handling the equipment, make sure that the capacity of the lifting equipment is suitable for the load.

 **WARNING!**

Unloading, transport and handling activities must be carried out by operators qualified and specially trained:

- on accident prevention rules;
- on maximum safety in the workplace;
- on the use of lifting equipment.

 **ATTENTION!**

Before handling the equipment:

- remove any movable or hanging component or firmly secure it to the load;
- protect the most fragile equipment;
- check that the load is stable.

### 5.3.1 - FORKLIFT HANDLING METHOD

**HAZARD!**

It is forbidden to:

- transit under suspended loads;
- move the load over the personnel operating in the site/plant area.

**WARNING!**



The following is not allowed on forklifts:

- carrying passengers;
- lifting people.

**NOTICE!**

Packaging must be always handled in a vertical position

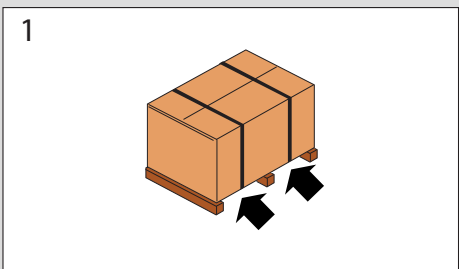
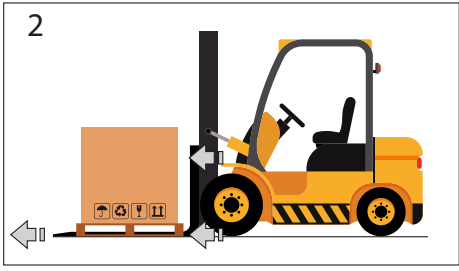
Proceed as follows:

Step	Action	Image
1	Place the forks of the forklift under the load surface.	
2	Make sure that the forks protrude from the front of the load (by at least 5 cm), far enough to eliminate any risk of the transported load tipping.	
3	Raise the forks until they are touching the load. <b>NOTICE!</b> Fasten the load to the forks with clamps or similar devices if required.	
4	Slowly lift the load by a few dozen centimetres and check its stability, making sure that the centre of gravity of the load is at the centre of the lifting forks.	

Step	Action	Image
5	Tilt the mast backwards (towards the driver's seat) to help the over-turning moment and to ensure greater load stability during transport.	
6	Adjust transport speed according to the type of floor and load, avoiding jerky movements. <b>⚠ WARNING!</b> <b>If:</b> <ul style="list-style-type: none"> <li>• <b>obstacles along the path;</b></li> <li>• <b>particular operating situations;</b></li> </ul> <b>hinder operator visibility, the assistance of a ground operator is required, standing outside the range of action of the lifting equipment, with the task of signalling.</b>	-
7	Place the load in the chosen installation area.	-

Tab. 5.39

### 5.3.2 - CRANE HANDLING METHOD

**⚠ WARNING!**

CE-marked chains, ropes and eyebolts must be used. Do not use chains connected to each other by bolts. Always check that:

- the safety catch of the hook returns to the initial position;
- the ropes are in excellent condition and have adequate sections.

It is forbidden to:

- drag the load on the ground;
- operate near power lines;
- stand within the range of action of the crane.

**! NOTICE!**

**Packaging must be always handled in a vertical position.**

The equipment must be handled using the lifting points provided on the equipment itself. For proper transport, follow the procedure below:

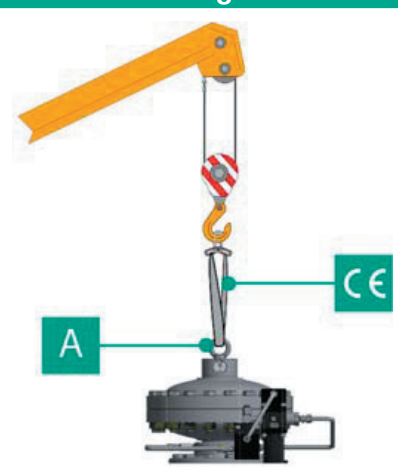
Step	Action	Image
1	Attach the lifting rope or chain to the appropriate supports (A). <b>⚠ WARNING!</b> <b>The lifting point is sized for lifting only the equipment, and not other parts of the system connected to it.</b>	
2	Slightly lift the load making sure the ropes or chains are secure. <b>! NOTICE!</b> <b>Check whether the load is properly balanced.</b>	
3	Handle the load avoiding sudden movements.	
4	Place the load in the chosen installation area.	

Tab. 5.40

## 5.4 - PACKAGING REMOVAL

Packaging removal	
<b>Operator qualification</b>	<ul style="list-style-type: none"> <li>Person in charge of transport, handling, unloading and placing on site;</li> <li>Installer.</li> </ul>
<b>PPE required</b>	<div style="display: flex; align-items: center;">  </div> <div style="background-color: #f4a460; padding: 5px; margin-top: 5px;"> <b>⚠ WARNING!</b> </div> <p>The PPE listed in this table is related to the risk associated with the equipment. For the PPE necessary to protect against risks associated with the workplace or operating conditions, please refer to:</p> <ul style="list-style-type: none"> <li>the regulations in force in the country of installation;</li> <li><u>any information provided by the Safety Manager at the installation facility.</u></li> </ul>

Tab. 5.41

To unpack the equipment in a cardboard box, proceed as follows:

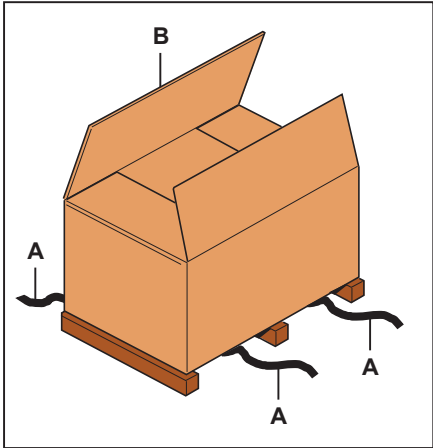
Step	Action	Image
1	Remove the straps (A).	
2	Remove the packaging cardboard (B).	
3	Remove the fasteners that secure the equipment to the base (if any).	
4	Move the equipment from the base to the place intended for it. <div style="border: 1px solid blue; padding: 5px; margin-top: 5px;"> <b>⚠ NOTICE!</b>  <b>Have at least 2 operators manually move the equipment, if required due to its dimensions/weight.</b> </div>	

Tab. 5.42

### ⚠ NOTICE!

After removing all packaging materials, check for any anomalies.

If there are anomalies:

- do not install the equipment;
- contact PIETRO FIORENTINI S.p.A. and specify the details provided on the equipment rating plate.

### 5.4.1 - PACKAGING DISPOSAL

### ⚠ NOTICE!

Sort the various materials making up the packaging and dispose of them in compliance with the regulations in force in the country of installation.

## 5.5 - STORAGE AND ENVIRONMENTAL CONDITIONS

If the equipment needs to be stored for an extended period, the minimum environmental conditions for the intended storage are provided. Only by complying with these requirements can the declared performance be guaranteed:

Conditions	Data
Maximum storage period	Maximum 3 years. <div style="border: 1px solid black; padding: 5px;">  <b>NOTICE!</b>  <b>For installations in later periods, see paragraph "5.5.1 - Pre-installation warnings after prolonged storage".</b> </div>
Temperature	Not above 25°C
Humidity	Not above 70%
Radiation	Away from radiation sources according to UNI ISO 2230:2009

Tab. 5.43

### 5.5.1 - PRE-INSTALLATION WARNINGS AFTER PROLONGED STORAGE

For installations that have been stored for longer than 3 years, the condition of all rubber parts must be checked and, if found to be damaged, they must be replaced in order to ensure the correct functioning of the equipment.

For the replacement of the rubber parts of the equipment, please refer to chapter "9 - Maintenance and functional checks".

<div style="border: 1px solid black; padding: 5px;">  <b>NOTICE!</b>  <b>PIETRO FIORENTINI S.p.A. recommends checking the condition of rubber parts in case of downtime or storage longer than 3 years.</b> </div>
--

PAGE INTENTIONALLY LEFT BLANK

## 6 - INSTALLATION

### 6.1 - INSTALLATION PRE-REQUISITES

#### 6.1.1 - ENVIRONMENTAL CONDITIONS ALLOWED

##### WARNING!

**To safely use the equipment, in full respect of the allowed environmental conditions, follow the data shown on the regulator plate and on any accessories (refer to paragraph “2.7 - Applied rating plates”).**

The installation site must be suitable for the safe use of the equipment.

The equipment installation area must have lighting that guarantees the operator good visibility during the work phases on the equipment.

##### NOTICE!

**The equipment must operate in places that are properly lit by artificial lighting suitable for the protection of the operator (in compliance with UNI EN 12464-1:2011 and UNI EN 12464-2:2014). If maintenance work is to be performed in areas and/or parts that are poorly lit, it is mandatory to:**

- use all the light sources of the installation plant;
- be equipped with a lighting system handheld or connected to the power supply network, compliant with Directive 2014/34/EU (ATEX) for use in environments at risk of explosion;
- adhere to the temperature specified on the equipment nameplate.

### 6.1.2 - CHECKS BEFORE INSTALLATION

The device does not require any further upstream safety device for protection against any overpressure with respect to its **PS admissible pressure** when, for the upstream reduction station, the maximum incidental downstream pressure is:

$$\text{MIPd} \leq 1.1 \text{ PS}$$

**MIPd** = Maximum incidental downstream pressure value (for further information, see UNI EN 12186:2014).

#### **ATTENTION!**







**If the installation of the equipment requires the application of compression fittings, these must be installed in accordance with the instructions of the Manufacturer of the fittings themselves.**

**The choice of fittings must be compatible with:**

- the use specified for the equipment;
- the plant specifications when required.

Before installation, it must be ensured that:

- the expected dimensions of the installation site are compatible with those of the equipment;
- there are no impediments for the workers in charge of maintenance;
- the upstream and downstream pipes are at the same level and can bear the weight of the equipment;
- the inlet and outlet connections of the pipes are aligned on the flanges;
- the inlet and outlet connections of the equipment are clean and intact;
- the inside of the upstream pipe is clean and free of processing residues such as welding slag, sand, paint residues, water, etc...

Installation	
<b>Operator qualification</b>	Installer
<b>PPE required</b>	<div style="display: flex; align-items: center;">      </div> <div style="background-color: #f4a460; padding: 5px; margin-top: 5px;">  <b>WARNING!</b> </div> <p><b>The PPE listed in this table is related to the risk associated with the equipment. For the required PPE to protect against risks associated with the workplace, installation or operating conditions, please refer to:</b></p> <ul style="list-style-type: none"> <li>• the regulations in force in the country of installation;</li> <li>• any information provided by the Safety Manager at the installation facility.</li> </ul>
<b>Equipment required</b>	Please refer to the chapter "7 - Commissioning/maintenance equipment".

Tab. 6.44

## 6.2 - SPECIFIC SAFETY INSTRUCTIONS FOR THE INSTALLATION PHASE

### **WARNING!**

Before proceeding with installation, make sure that the upstream and downstream valves installed on the line are shut off.

---

### **WARNING!**

Installation may also take place in areas where there is a risk of explosion, which implies that all necessary prevention and protection measures have to be taken.

For these measures, please refer to the regulations in force at the place of installation.

---

### 6.3 - GENERAL INFORMATION ON CONNECTIONS

The equipment must be installed in-line with an arrow on the body pointing to the gas flow direction. In line installation as well as squared installation, the following must be present:

Pos.	Description
1	1 <b>slam shut valve upstream</b> of the equipment
2	2 <b>vent valves</b> set up one upstream and one downstream of the equipment.
3	2 <b>pressure gauges</b> set up one upstream and one downstream of the equipment.
4	1 <b>pressure regulator</b> .
5	1 <b>downstream shut-off valve</b> .

Tab. 6.45

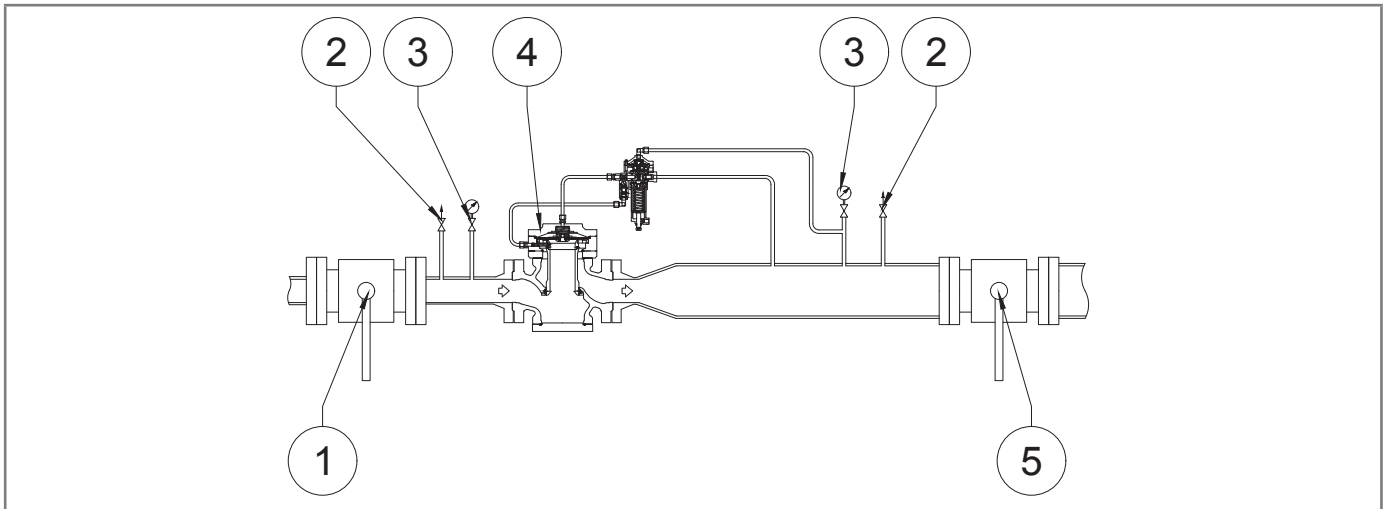

Fig. 6.18. In-line installation

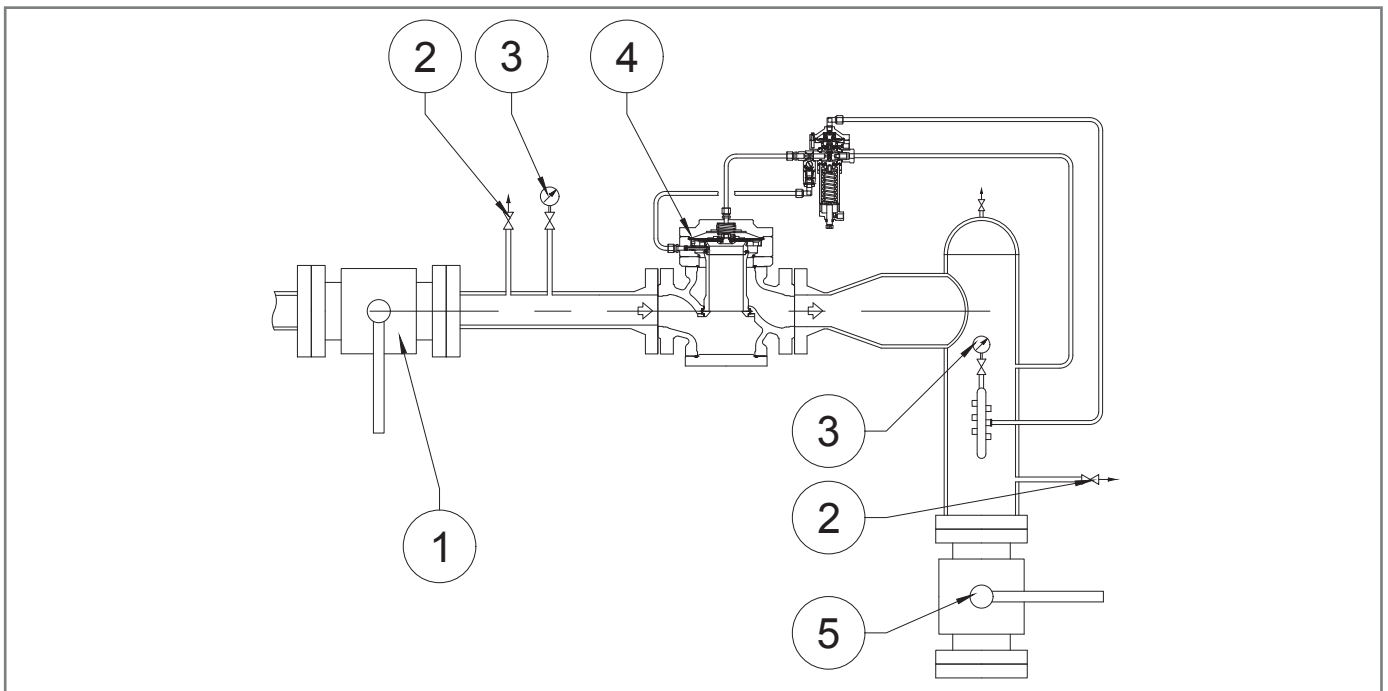

Fig. 6.19. Angle installation

**! NOTICE!**

When used in gas pressure reduction stations, the device must be installed at least according to the requirements of standards UNI EN 12186:2014 or UNI EN 12279:2007.

Equipment vents must be ducted in accordance with UNI EN 12186:2014 or UNI EN 12279:2007 or the standards in force at the place of installation of the equipment.

## 6.4 - REGULATOR INSTALLATION POSITIONS

Below are the typical set ups of the regulator:

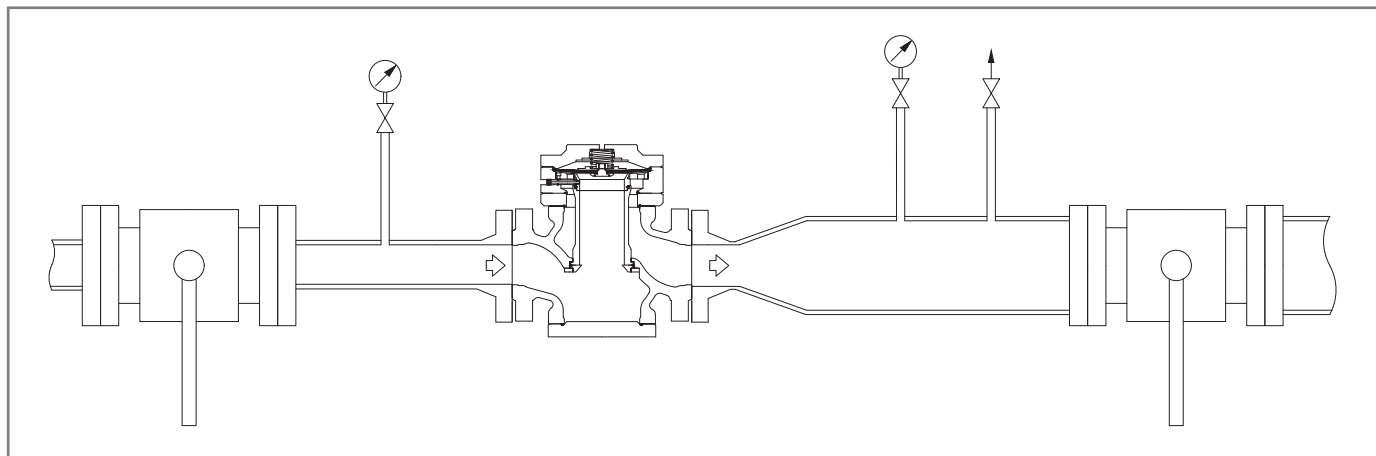

Fig. 6.20. Standard position

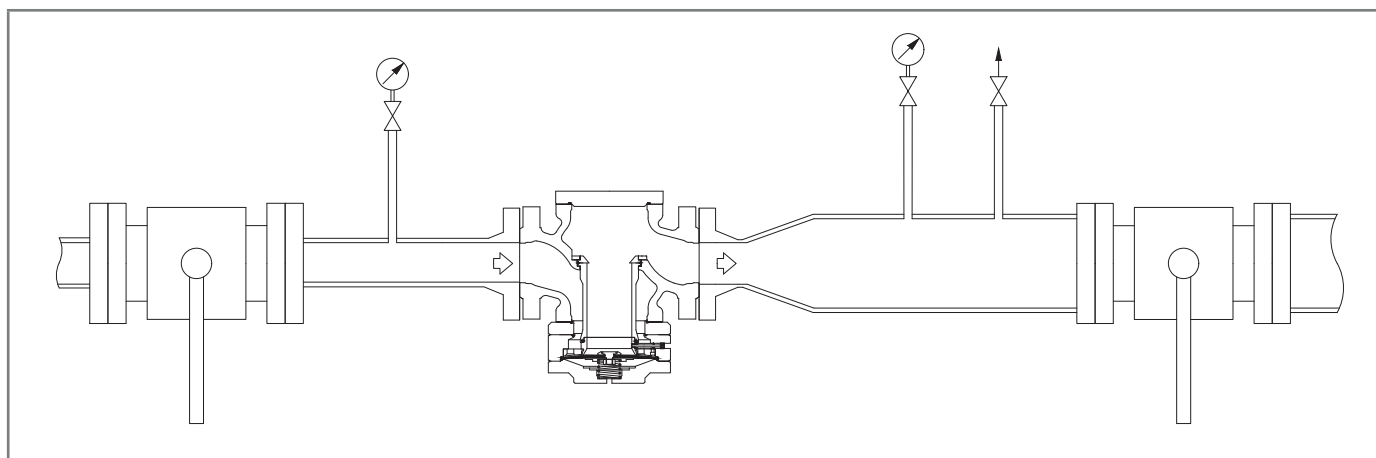

Fig. 6.21. Inverted position

## 6.5 - INSTALLATION PROCEDURE

### 6.5.1 - EQUIPMENT INSTALLATION PROCEDURE

To install the equipment in line and squared, proceed as follows:

Step	Action
1	Place the equipment in the section of the line designated for it.
2	Place the gaskets between the line flange and the regulator flange.
3	Insert the bolts into the appropriate holes of the connecting flanges.
4	Screw the bolts following the technical rules for tightening flanges.

Tab. 6.46

### 6.5.2 - CONNECTION OF THE SENSING LINES TO THE DOWNSTREAM PIPING

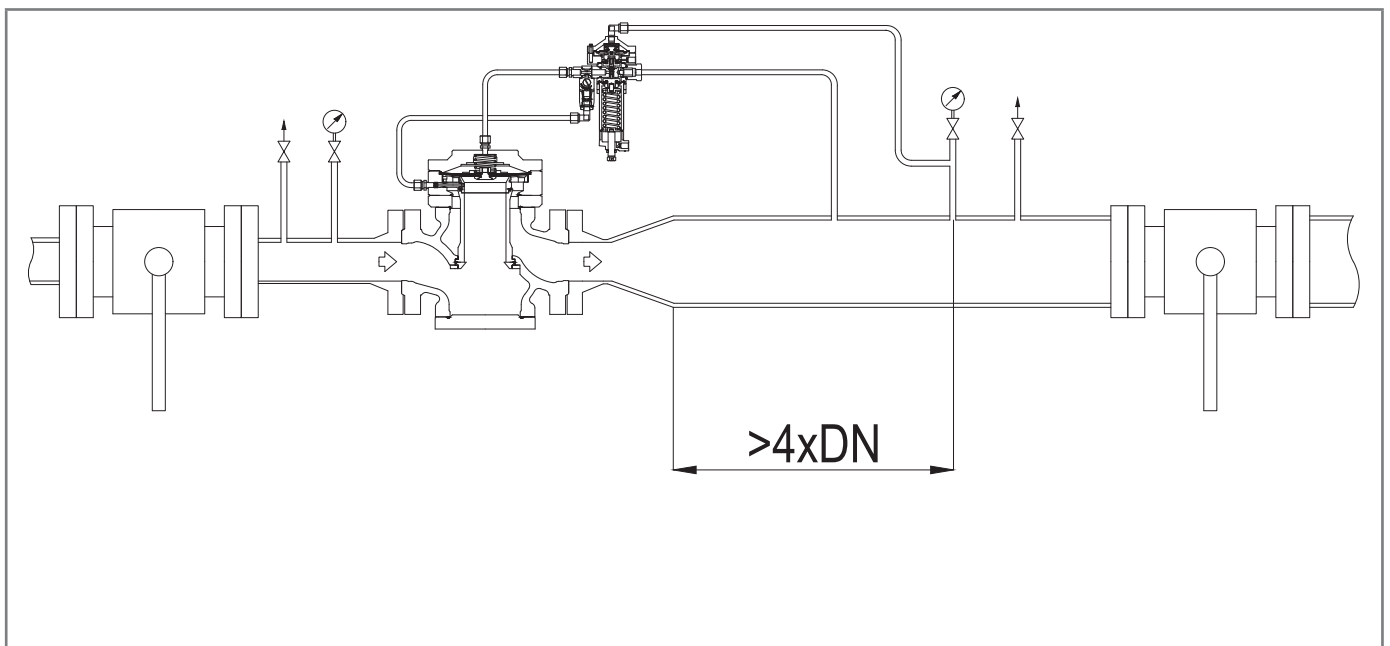

Fig. 6.22. Connection of sensing lines to the downstream piping

For proper adjustment, it is essential that:

- the downstream shut-off valve is placed at a distance of at least 6 times the nominal diameter of the pipe downstream of the regulator;
- the downstream sensing lines are placed on a straight section of pipe (with uniform diameter) having a length equal to at least 4 times the rated diameter of the pipe itself;

#### **ATTENTION!**

**The pilot drain must not be connected to the multi-socket switch.**

For optimum performance, the velocity of the pressurised fluid at the intake point should not exceed the following values:

- $V_{max} = 30 \text{ m/s}$  for  $P_a > 5 \text{ bar}$
- $V_{max} = 25 \text{ m/s}$  for  $P_a < 5 \text{ bar}$

As a limitation of use, the velocity of the pressurised fluid at the intake point does not exceed the following values:

- $V_{max} = 40 \text{ m/s}$  for  $P_a > 5 \text{ bar}$

To calculate the flow rate, use the following formula:

$$V = 345,92 \times \frac{Q}{DN^2} \times \frac{1 - 0,002 \times Pd}{1 + Pd}$$

**V** = gas velocity in m/sec

**Q** = gas flow rate in Sm<sup>3</sup>/h

**DN** = nominal diameter of the regulator in mm

**Pd** = regulator outlet pressure in barg

**NOTICE!**

**All on-site pneumatic connections must have pipes with a minimum internal diameter of 8 mm**

To prevent the sensing line pipes from collecting impurities and condensation, it is necessary that:

- the pipe connections are always welded on the upper part or at maximum 90 degrees on the axis of the pipe (refer to fig. 6.23);
- the hole in the piping has no burrs or internal protrusions;
- the slope of the pipe is always 5-10% towards the downstream pipe connection.

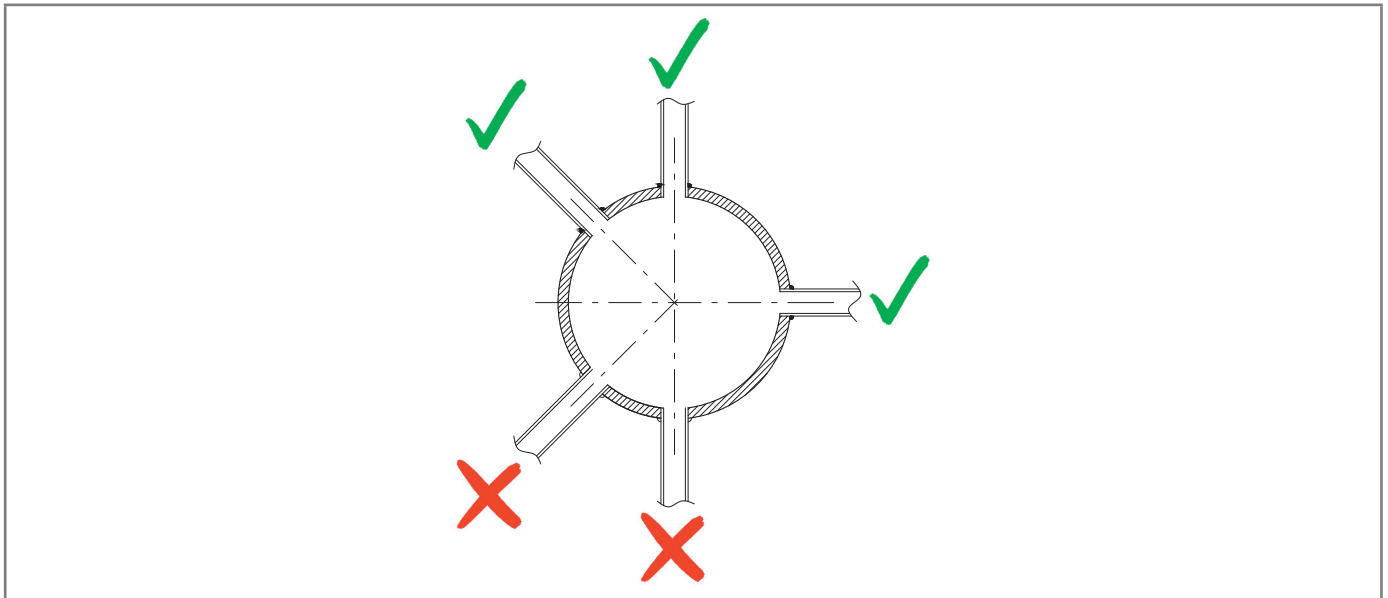

Fig. 6.23. Welded pipe connections

If there is a sensing line, connect the equipment connections as shown below:

- 1 and 2 to the discharge outlet of the control head of the PM/819 monitor, if any;
- 3 and 4 to the pilot sensing lines;
- 5 and 6 to the throttle sensing lines of the block, when present.

**! NOTICE!**

**If there is a multiple sensing line, it is not recommended to place shut-off valves on sensing lines.  
In any case, follow the regulations in force in the place of installation and use of the equipment.**

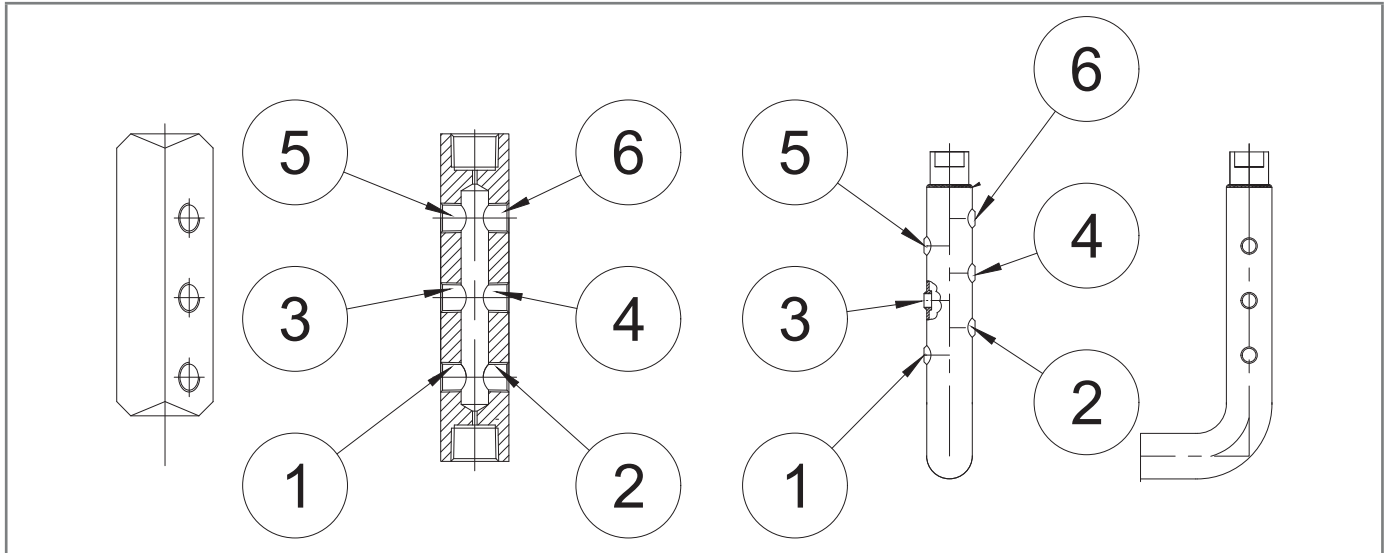

Fig. 6.24. Equipment connections

## 6.6 - POST-INSTALLATION AND PRE-COMMISSIONING CHECKS

When the equipment is operating, make sure that all connections are:

- properly secured/tightened to prevent any leakage during commissioning;
- connected correctly.







## 7 - COMMISSIONING/MAINTENANCE EQUIPMENT





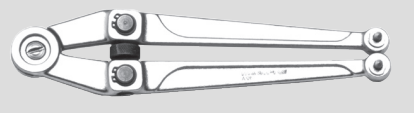

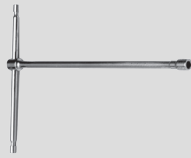

### 7.1 - LIST OF EQUIPMENT

Use of commissioning/maintenance equipment	
<b>Operator qualification</b>	<ul style="list-style-type: none"> <li>• Mechanical maintenance technician;</li> <li>• Electrical maintenance technician;</li> <li>• Installer;</li> <li>• User technician.</li> </ul>
<b>PPE required</b>	<div style="display: flex; align-items: center;">  </div> <div style="background-color: #f4a460; padding: 5px; margin-top: 5px;"> <p><b>⚠ WARNING!</b></p> </div> <p>The PPE listed in this table is related to the risk associated with the equipment. For the required PPE to protect against risks associated with the workplace, installation or operating conditions, please refer to:</p> <ul style="list-style-type: none"> <li>• the regulations in force in the country of installation;</li> <li>• any information provided by the Safety Manager at the installation facility.</li> </ul>

Tab. 7.47

We list the types of equipment required for commissioning and maintenance of the appliance:

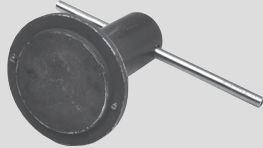
Ref.	Equipment type	Image
<b>A</b>	Combination wrench	
<b>B</b>	Adjustable wrench	
<b>C</b>	Compass wrench	
<b>D</b>	Double ended bi-hex tubular socket wrench	
<b>E</b>	Bent male hex wrench	
<b>F</b>	Male hex T-key	

Ref.	Equipment type	Image
G	T-handle hexagon socket spanner	
H	Phillips screwdriver	
I	Slotted screwdriver	
L	O-ring extraction tool	
M	Circlip pliers	
N	Fiorentini special key	
O	Fiorentini special key	
P	Fiorentini special tool	

Tab. 7.48

## 7.2 - EQUIPMENT NEEDED FOR THE DIFFERENT CONFIGURATIONS

Each table is distinguished by:

Term	Description
<b>Ref.</b>	Reference to the equipment indicated in "Tab. 7.48".
<b>Type</b>	Type (size) or code of the equipment.
<b>DN</b>	Indicates the Nominal Diameter of the reference configuration.

Tab. 7.49

Aperflux 851								
Equipment		DN						
Ref.	Type	1"	2"	3"	4"	6"	8"	10"
<b>A</b>	K./Wr.	14-17-19-24-27	14-17-19-24-27	14-17-19-24-27-32	14-17-19-24-27-32	14-17-19-24-27-32	14-17-19-24-27-32	14-16-17-29-24-27-32-36
<b>B</b>	L.	300						
<b>C</b>	Ø	4						
<b>F</b>	K./Wr.	5-6	5-6	5-6-10	5-6-14	5-6-17	5-6-17	4-5-6-17
<b>I</b>	L.	6.5 x 100						
<b>L</b>	Code	7999099						

*Tab. 7.50*

Aperflux 851 + DB/851								
Equipment		DN						
Ref.	Type	1"	2"	3"	4"	6"	8"	10"
<b>A</b>	K./Wr.	14-17-19-24-27	14-17-19-24-27	14-17-19-24-27-32	14-17-19-24-27-32	14-17-19-24-27-32	14-17-19-24-27-32	14-16-17-29-24-27-32-36
<b>B</b>	L.	300						
<b>C</b>	Ø	4						
<b>F</b>	K./Wr.	5-6	5-6	5-6-10	5-6-14	5-6-17	5-6-17	4-5-6-17
<b>I</b>	L.	6.5 x 100						
<b>L</b>	Code	7999099						
<b>O</b>	Code	7999020	7999022	7999023	7999024	7999025	7999027	7999028

*Tab. 7.51*

Aperflux 851 + PM/819								
Equipment		DN						
Ref.	Type	1"	2"	3"	4"	6"	8"	10"
<b>A</b>	K./Wr.	14-17-19-24-27	14-17-19-24-27	14-17-19-24-27-32	14-17-19-24-27-32	14-17-19-24-27-32	14-17-19-24-27-32	14-16-17-29-24-27-32-36
<b>B</b>	L.	300						
<b>C</b>	Ø	4						
<b>D</b>	K./Wr.	-	-	-	-	27-41	27-41	30-41-55
<b>E</b>	K./Wr.	3-12	3-12	3-12	3-12	3-12	3-12	3-12
<b>F</b>	K./Wr.	5-6	5-6	5-6-10	5-6-14	5-6-17	5-6-17	4-5-6-17
<b>G</b>	K./Wr.	9-17-20	9-17-20	9-17-19-22	9-17-19-22	9-22	9-22	-
<b>I</b>	L.	6.5 x 100						
<b>L</b>	Code	7999099						

*Tab. 7.52*

Aperflux 851 + SB/82								
Equipment		DN						
Ref.	Type	1"	2"	3"	4"	6"	8"	10"
<b>A</b>	K./Wr.	14-17-19-- 24-27	14-17-19 24-27	14-17-19- 24-27-32	14-17-19- 24-27-32	14-17-19- 24-27-32	14-17-19- 24-27-32	14-16-17- 29-24-27- 32-36
<b>B</b>	L.	300						
<b>C</b>	Ø	4						
<b>D</b>	K./Wr.	9-10-15-24	9-10-15-24	9-10-15-24	9-10-15-24	9-10-15-24	9-10-15-24	27
<b>E</b>	K./Wr.	2-3-4-8	9-10-15-24	9-10-15-24	9-10-15-24	9-10-15-24	9-10-15-24	27
<b>F</b>	K./Wr.	2-3-4-8	2-3-4-10	2-3-4	2-3-4	2-3-4	2-3-4	2-3-4
<b>I</b>	L.	6.5 x 100						
<b>L</b>	Code	7999099						
<b>M</b>	Ø	16-60						
<b>N</b>	Code	7999019						

*Tab. 7.53*

Aperflux 851 + HB/97					
Equipment		DN			
Ref.	Type	4"	6"	8"	10"
<b>A</b>	K./Wr.	7-14-17-19-22-24- 27-30-32-41	7-14-17-19-22-24- 27-30-32-41	7-14-17-19-22-24- 27-32-41	7-14-16-17-19-24- 27-32-36-50-57
<b>B</b>	L.	300			
<b>C</b>	Ø	4			
<b>D</b>	K./Wr.	9-10-15-17-21- 22-24-27	9-10-15-17-21- 22-24-27	9-10-15-17-21- 22-24-27	17-21-27-30
<b>E</b>	K./Wr.	9-10-15-24	9-10-15-24	9-10-15-24	27
<b>F</b>	K./Wr.	2-3-4-5-6	2-3-4-5-6	2-3-4-5-6	2-3-4-5-6-17
<b>I</b>	L.	6.5 x 100			
<b>L</b>	Code	7999099			
<b>M</b>	Ø	16-60			
<b>N</b>	Code	7999019			
<b>P</b>	Code	7999097			

*Tab. 7.54*

## 8 - COMMISSIONING

### 8.1 - GENERAL WARNINGS

#### 8.1.1 - SAFETY REQUIREMENTS FOR COMMISSIONING

##### HAZARD!

During commissioning the risks associated with any discharges to the atmosphere of flammable or noxious gases must be evaluated.

##### HAZARD!

In case of installation on distribution networks for natural gas, consider the risk associated with explosive mixtures (gas/air) being formed inside the piping, if the line is not subjected to inerting.

##### WARNING!

During commissioning, any unauthorised personnel must keep away.  
The 'no entry' area has to be marked with signs and/or boundaries.

##### NOTICE!

Commissioning has to be carried out by authorised and qualified personnel.

The equipment is supplied with the pilot unit already calibrated.

Even if the built-in monitor PM/819 or the built-in slam shut valves SB/82 and HB/97 are fitted to the equipment, any pilots or pressure switches present will already be calibrated.



##### NOTICE!

It is possible that for various reasons (e.g. vibrations during transport) the calibration of the equipment's accessories may vary, although within the values indicated on the identification plates.

Before commissioning the equipment, it is necessary to check that:

- all shut-off valves (inlet, outlet, any bypass) are closed;
- the gas is at a temperature within the limits specified on the data plate.

#### Commissioning

<b>Operator qualification</b>	<ul style="list-style-type: none"> <li>• Installer;</li> <li>• Qualified technician.</li> </ul>
<b>PPE required</b>	 <p> <b>WARNING!</b></p> <p>The PPE listed in this table is related to the risk associated with the equipment. For the required PPE to protect against risks associated with the workplace, installation or operating conditions, please refer to:</p> <ul style="list-style-type: none"> <li>• the regulations in force in the country of installation;</li> <li>• <u>any information provided by the Safety Manager at the installation facility.</u></li> </ul>
<b>Equipment required</b>	Please refer to the chapter "7 - Commissioning/maintenance equipment".

Tab. 8.55

## 8.2 - PRELIMINARY PROCEDURES FOR COMMISSIONING

### HAZARD!

Before commissioning the equipment, it must be ensured that any source of explosion has been eliminated if there is such a danger.

### WARNING!

Before commissioning, you need to make sure that the characteristics of the equipment are suitable for the conditions of use.

### ATTENTION!

To protect the equipment from damage, the following operations must never be carried out:

- pressurisation through a valve located downstream of the equipment;
- depressurise the equipment through a valve located upstream of it.

Commissioning can be carried out using two different procedures:

### Commissioning types

<b>Injection of an inert fluid</b>	Pressurising the equipment by injecting an inert fluid (e.g. nitrogen) to avoid potentially explosive mixtures for services with combustible gases. <div style="background-color: #f4a460; padding: 5px;"><b> WARNING!</b></div> <b>During pressurisation, always check that the equipment has no leaks.</b>
<b>Direct injection</b>	Direct injection of gas into pipes, keeping the gas velocity in the pipes as low as possible (maximum permitted value of 5 m/s).

Tab. 8.56

### 8.3 - PROPER COMMISSIONING CHECK

Thoroughly spray the equipment with a foam solution to check the tightness of the external surfaces of the regulator and the connections made during installation (or equivalent control system).

### 8.4 - CALIBRATION OF ANY ACCESSORIES

To properly calibrate all the accessories in the equipment, refer to table below where, starting from the calibration of the regulator, all relevant values are defined:

**Calibration of a line consisting of: Aperflux 851 + built-in monitor PM/819  
or slam shut valve SB/82  
or HB/97 + LINE OFF 2.0/Pressure switch**

Calibration REGULATOR (Pd) bar	Calibration MONITOR	Calibration ACCELERATOR	Calibration Max pressure SLAM-SHUT DE- VICE	Calibration Min pressure SLAM-SHUT DE- VICE
0.8 ÷ 2.1	Pd x 1.1	Pd x 1.2	Pd x 1.5	Pd - 0.3 bar
2.1 ÷ 5	Pd x 1.1	Pd x 1.2	Pd x 1.2	Pd - 0.5 bar
5 - 25	Pd x 1.05	Pd x 1.1	Pd x 1.3	Pd - 3 bar
25 - 60	Pd x 1.03	Pd x 1.06	Pd x 1.3	Pd - 5 bar

Tab. 8.57

### 8.5 - REGULATOR COMMISSIONING PROCEDURE

In the application consisting of multiple pressure adjusting lines, it is advisable to commission one line at a time, starting with the line with the lowest set point.

The set point value is mentioned on the test certificate enclosed with each piece of equipment.

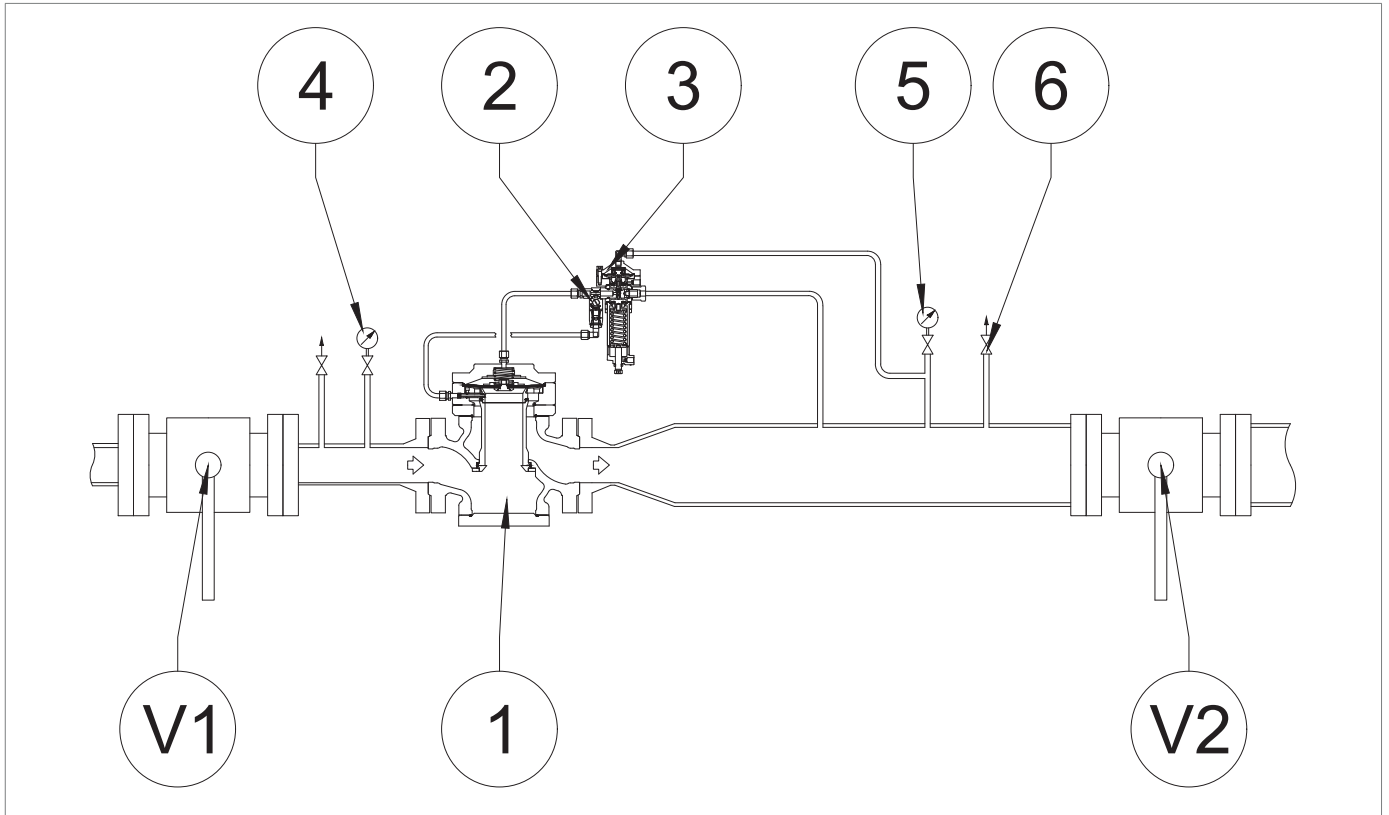





Fig. 8.25. Commissioning the regulator

Step	Action
1	Open the vent cock (6).
2	Completely unscrew the fixing nut of the pilot screw (3).
3	Turn the screw of the AR100 throttle valve (2) to a value between 3 and 5.
4	Open the inlet shut-off valve V1 very slowly. <div style="border: 1px solid black; padding: 5px; margin-top: 5px;">  <b>NOTICE!</b>  <b>Check the pressure by referring to the pressure gauge (4) located upstream.</b> </div>
5	Close the drain cock (6) and check that the downstream pressure, after an increase phase, does not exceed the closing pressure value (refer to the SG value specified with reference to the calibration/set-point value). <div style="border: 1px solid black; padding: 5px; margin-top: 5px;">  <b>NOTICE!</b>  <b>If the downstream pressure exceeds the closing pressure value, refer to chapter "10 - Troubleshooting".</b> </div>
6	Using a foaming agent, check all the junctions between shut-off valves (V1 and V2) for proper sealing.
7	Open the downstream shut-off valve (V2) very slowly until the piping has been filled completely. <div style="border: 1px solid black; padding: 5px; margin-top: 5px;">  <b>NOTICE!</b>  <b>If at the beginning of this operation the pressure in the downstream pipeline is much lower than the calibration pressure, it will be advisable to partially open this valve so as not to exceed the maximum flow rate of the system.</b> </div>
8	Readjust the calibration set at <b>Step 3</b> : <ul style="list-style-type: none"> <li>• by increasing the opening of the screw of the AR100 throttle valve (2), if pumping phenomena occur under normal operating conditions</li> <li>• by decreasing the opening of the screw of the AR100 throttle valve (2), if an excessive decrease in the regulated pressure occurs as the flow rate increases.</li> </ul>
9	Secure the pilot screw with the fastening nut.

Tab. 8.58

## 8.6 - PROCEDURE FOR COMMISSIONING THE APERFLUX 851 REGULATOR WITH PM/819 BUILT-IN MONITOR

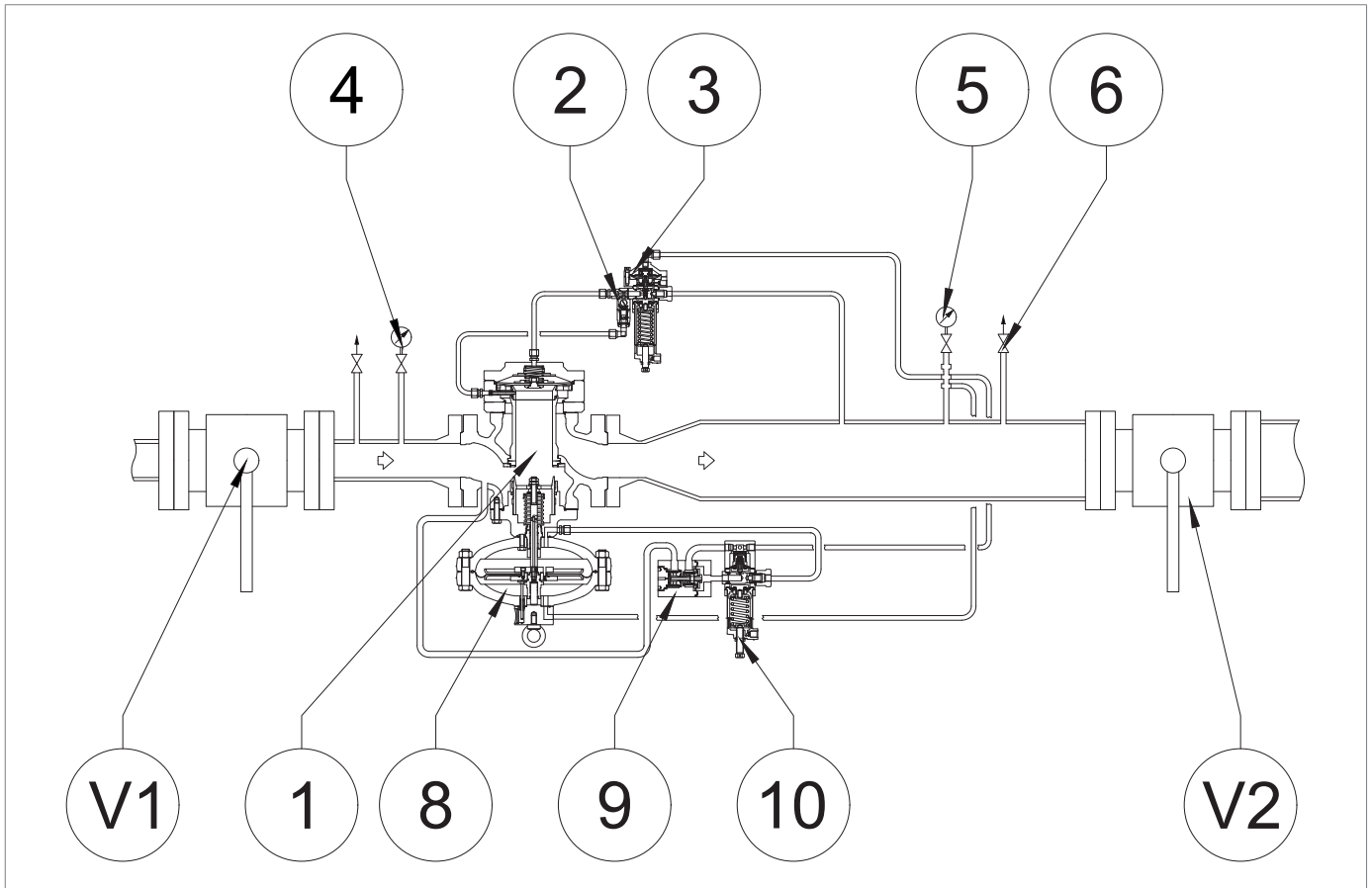







Fig. 8.26. Procedure for commissioning the regulator with PM/819 built-in monitor

Step	Action
1	Partially open the bleed cock (6).
2	Completely unscrew the pilot screw nut (positions 3 and 10).
3	Completely compress the pilot spring (3) by turning the adjusting screw clockwise.
4	Completely relieve the pilot spring (10) by turning the adjusting screw anti-clockwise.
5	Close the screw of the AR100 throttle valve (2) to value 1.
6	Open the inlet shut-off valve V1 very slowly. <b>NOTICE!</b> <b>Check the pressure by referring to the pressure gauge (4) located upstream.</b>
7	Turn the adjustment screw on the monitor pilot (10) clockwise to increase the downstream pressure value to the selected monitor operating value. <b>NOTICE!</b> <b>Check the pressure referring to the pressure gauge (5) located upstream.</b>
8	Turn the screw of the AR100 throttle valve (2) to a value between 3 and 5.
9	Turn the adjusting screw on the pilot (3) anti-clockwise to relieve the calibration spring until the regulator trips.

Step	Action
10	<p>Make sure that the PM/819 monitor (8) is fully open (100%) by checking the position of the stroke indicator rod.</p> <div style="border: 1px solid black; padding: 5px;">  <b>NOTICE!</b> </div> <p><b>Check the pressure referring to the pressure gauge (5) located upstream.</b></p>
11	<p>Slowly close the drain cock (6) and check that the downstream pressure, after an increase phase, does not exceed the closing pressure value (refer to the SG value of the specified monitor with reference to the calibration/set-point value).</p> <div style="border: 1px solid black; padding: 5px;">  <b>NOTICE!</b> </div> <p><b>If the downstream pressure exceeds the closing pressure value, refer to chapter “10 - Troubleshooting” to clear the causes of the malfunctions.</b></p> <div style="border: 1px solid black; padding: 5px;">  <b>NOTICE!</b> </div> <p><b>Check the pressure referring to the pressure gauge (5) located upstream.</b></p>
12	<p>Using a foaming agent, check all the junctions between shut-off valves (V1 and V2) for proper sealing.</p>
13	<p>Open the downstream shut-off valve V2 very slowly until the pipeline fills completely.</p> <div style="border: 1px solid black; padding: 5px;">  <b>NOTICE!</b> </div> <p><b>If at the beginning of this operation the pressure in the pipeline is much lower than the calibration pressure, it will be advisable to partially open this valve so as not to exceed the maximum flow rate of the system.</b></p> <div style="border: 1px solid black; padding: 5px;">  <b>NOTICE!</b> </div> <p><b>Check the pressure referring to the pressure gauge (5) located upstream.</b></p>
14	<p>Readjust the calibration set in <b>Step 8</b>:</p> <ul style="list-style-type: none"> <li>• by increasing the opening of the screw of the AR100 throttle valve (2), if pumping phenomena occur under normal operating conditions</li> <li>• by decreasing the opening of the screw of the AR100 throttle valve (2), if an excessive decrease in the regulated pressure occurs as the flow rate increases.</li> </ul>
15	<p>Secure the screws of the pilots with the appropriate fastening nuts.</p>

Tab. 8.59

## 8.7 - COMMISSIONING PROCEDURE FOR THE APERFLUX 851 REGULATOR WITH BUILT-IN PM/819 MONITOR AND M/A THROTTLE

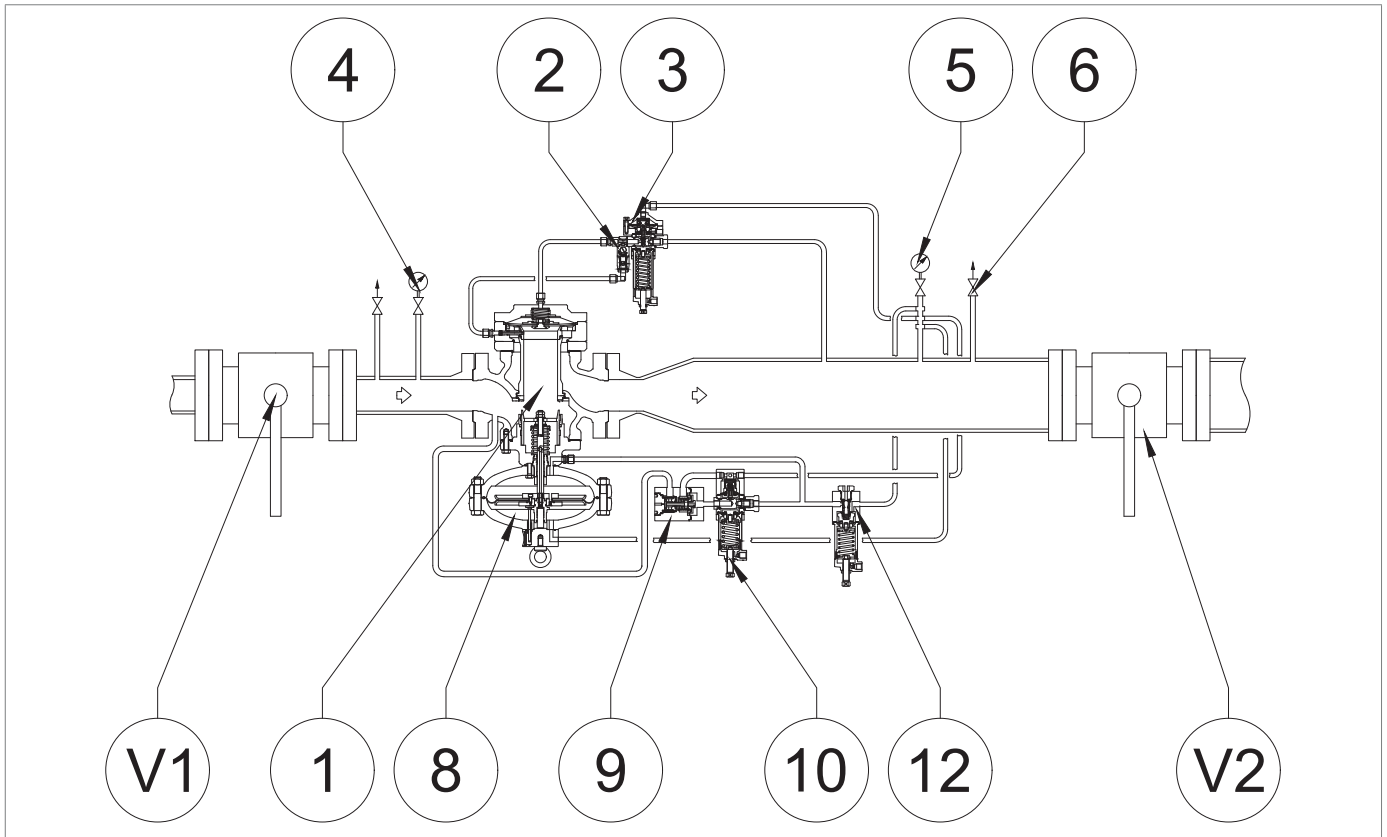

Fig. 8.27. Procedure for commissioning the regulator with PM/819 built-in monitor and M/A throttle

Step	Action
1	Partially open the bleed cock (6).
2	Completely unscrew the fastening nut of the pilot screw (positions 3 and 10) and the M/A throttle (12).
3	Completely compress the pilot spring (3) by turning the adjusting screw clockwise.
4	Completely relieve the pilot spring (10) by turning the adjusting screw anti-clockwise.
5	Fully compress the M/A throttle spring (12) by turning the adjusting screw clockwise.
6	Close the screw of the AR100 throttle valve (2) to value 1.
7	Open the inlet shut-off valve V1 very slowly. <b>NOTICE!</b> <b>Check the pressure by referring to the pressure gauge (4) located upstream.</b>
8	Slowly increase the downstream pressure by turning the monitor pilot adjustment screw (10) clockwise until the M/A throttle tripping pressure (12) is reached. <b>NOTICE!</b> <b>Check the pressure referring to the pressure gauge (5) located upstream.</b>
9	Turn the M/A throttle adjusting screw (12) anti-clockwise to decrease the setting of the cut-in pressure value until a foaming substance is found to be escaping from the gas outlet.

Step	Action
10	<p>Turn the monitor pilot adjustment screw (10) anti-clockwise to decrease the downstream pressure value to the selected monitor operating value, ensuring that the throttle valve (12) has cut off the gas discharge</p> <div style="border: 1px solid black; padding: 5px;"> <p><b>! NOTICE!</b></p> <p><b>Check the pressure referring to the pressure gauge (5) located upstream.</b></p> </div>
11	Secure the monitor pilot adjustment screw (10) with the nut (9).
12	Turn the screw of the AR100 throttle valve (2) to a value between 3 and 5.
13	<p>Turn the adjusting screw on the pilot (3) anti-clockwise to relieve the calibration spring until the regulator trips.</p> <div style="border: 1px solid black; padding: 5px;"> <p><b>! NOTICE!</b></p> <p><b>Check the pressure referring to the pressure gauge (5) located upstream.</b></p> </div>
14	Make sure that the PM/819 monitor (8) is fully open (100%) by checking the position of the stroke indicator rod.
15	<p>Slowly close the drain cock (6) and check that the downstream pressure, after an increase phase, does not exceed the closing pressure value (refer to the SG value of the specified monitor with reference to the calibration/set-point value).</p> <div style="border: 1px solid black; padding: 5px;"> <p><b>! NOTICE!</b></p> <p><b>If the downstream pressure exceeds the closing pressure value, refer to chapter “10 - Troubleshooting” to clear the causes of the malfunctions.</b></p> </div> <div style="border: 1px solid black; padding: 5px;"> <p><b>! NOTICE!</b></p> <p><b>Check the pressure referring to the pressure gauge (5) located upstream.</b></p> </div>
16	Using a foaming agent, check all the junctions between shut-off valves (V1 and V2) for proper sealing.
17	<p>Open the downstream shut-off valve V2 very slowly until the pipeline fills completely.</p> <div style="border: 1px solid black; padding: 5px;"> <p><b>! NOTICE!</b></p> <p><b>If at the beginning of this operation the pressure in the pipeline is much lower than the calibration pressure, it will be advisable to partially open this valve so as not to exceed the maximum flow rate of the system.</b></p> </div> <div style="border: 1px solid black; padding: 5px;"> <p><b>! NOTICE!</b></p> <p><b>Check the pressure referring to the pressure gauge located upstream.</b></p> </div>
18	<p>Repeat the operations of <b>Step 12</b>:</p> <ul style="list-style-type: none"> <li>• by increasing the opening of the screw of the AR100 throttle valve (2), if pumping phenomena occur under normal operating conditions</li> <li>• by decreasing the opening of the screw of the AR100 throttle valve (2), if an excessive decrease in the regulated pressure occurs as the flow rate increases.</li> </ul>
19	Secure the screws of the pilots with the appropriate fastening nuts.

Tab. 8.60

## 8.8 - COMMISSIONING PROCEDURE FOR THE APERFLUX 851 REGULATOR WITH BUILT-IN SLAM-SHUT VALVE SB/82

### 8.8.1 - CHECKING THE SB/82 SLAM-SHUT VALVE FOR PROPER SEALING WHEN CLOSING

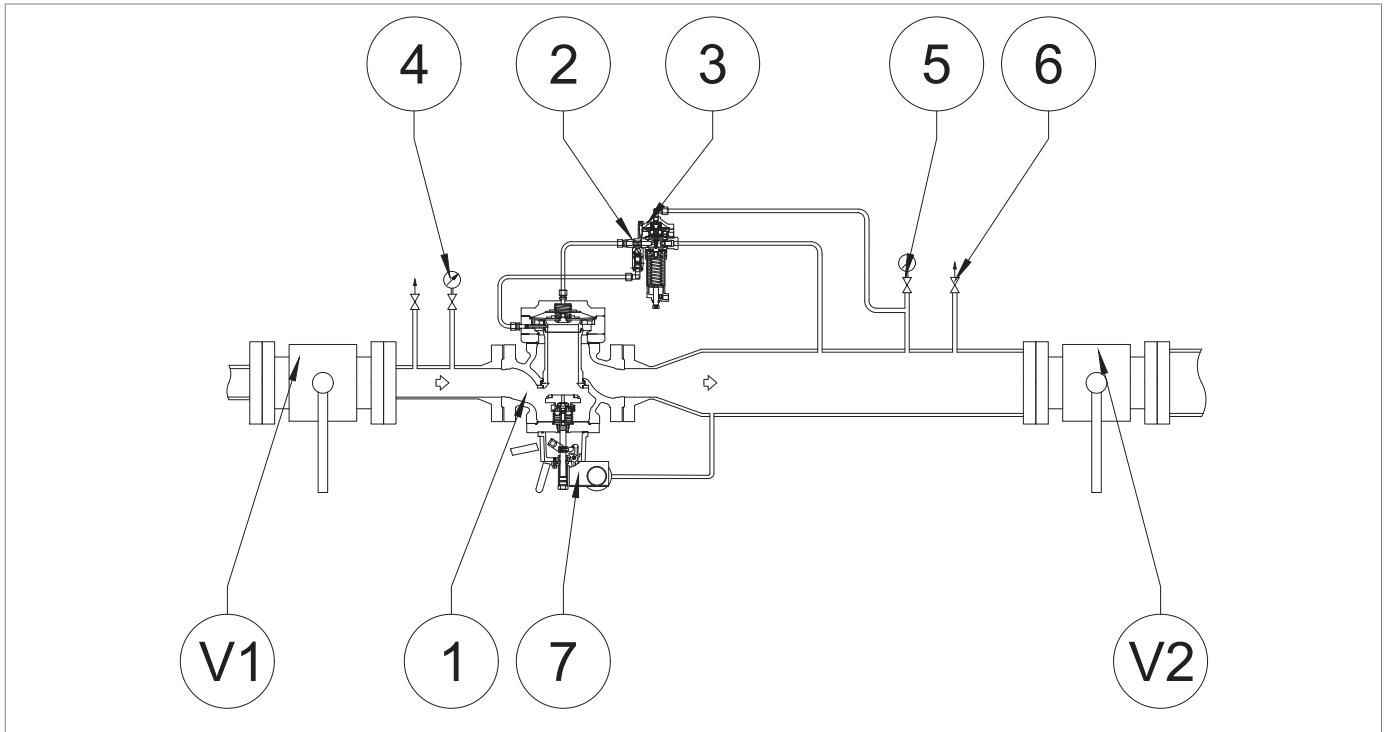

Fig. 8.28. Sealing of the SB/82 slam-shut valve when closing

Step	Action
1	Check that the slam-shut valve is in the shut-off position.
2	Completely relieve the pilot spring (3) by turning the adjusting screw anti-clockwise.
3	Open the vent (6) and drain the downstream section completely.
4	Disconnect the pipe (8) between the AR100 throttle valve (2) and the regulator head.
5	Slowly open upstream valve V1.
6	Check the tightness of the shut-off valve through the connection connected to the regulator head with a foaming substance. <b>! NOTICE!</b> <b>In case of leaks from the connection, see chapter "10 - Troubleshooting" to remove the causes of the dysfunction.</b>
7	Reconnect the pipe between the AR100 throttle valve (2) and the regulator head (1). <b>! NOTICE!</b> <b>Check whether to replace the fitting by referring to the fitting manufacturer's instructions.</b>
8	Check the calibration of the minimum pressure spring.

Tab. 8.61

## 8.8.2 - CALIBRATION PROCEDURE FOR PRESSURE SWITCHES MODELS 02M/102MH ÷ 105M/105MH

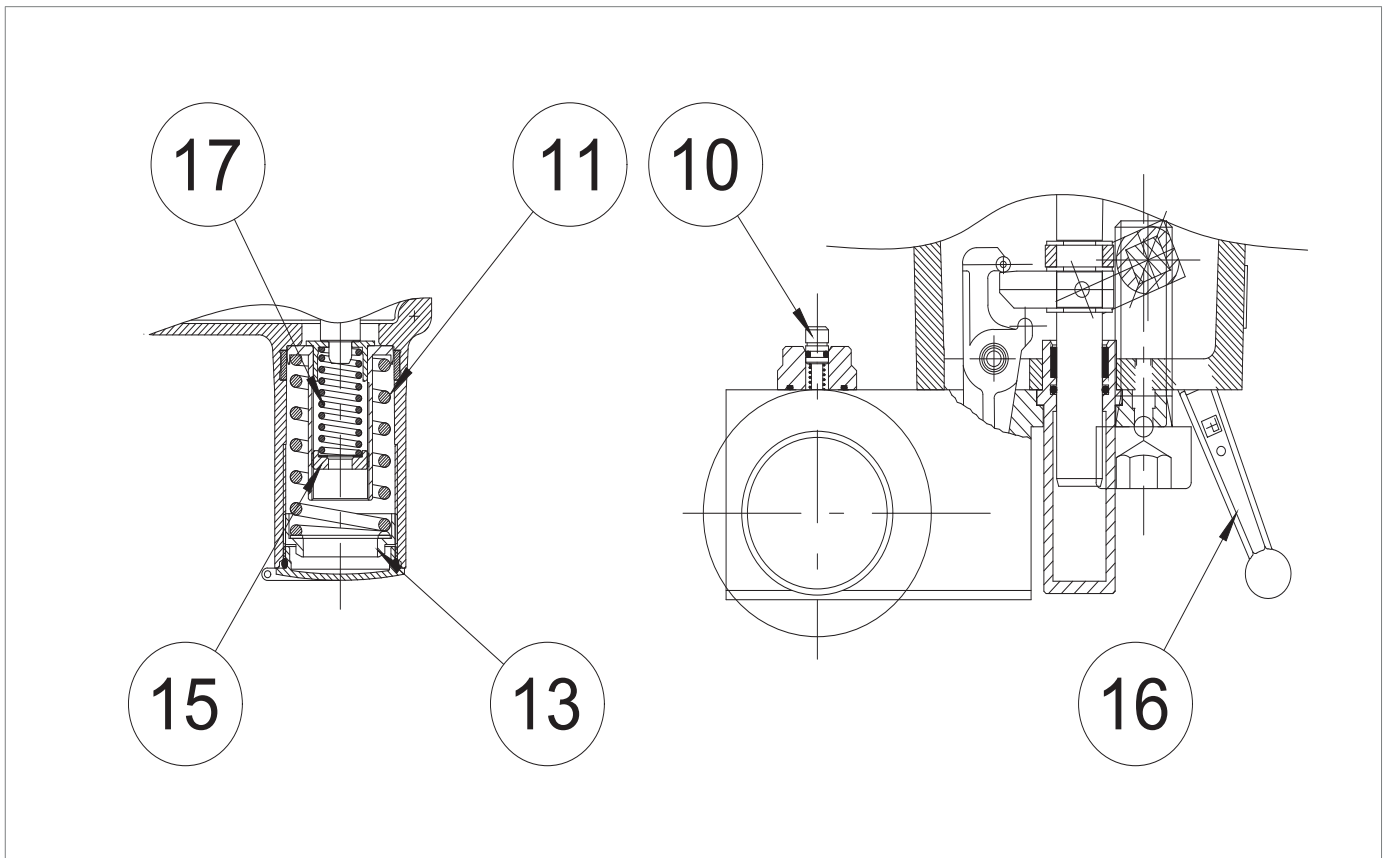





Fig. 8.29. Calibration of pressure switches models 102M/102MH ÷ 105M/105MH

### SPRING SETTING FOR MAXIMUM PRESSURE TRIPPING

Step	Action
	Increase the downstream pressure until the blockage is triggered by turning the pilot adjustment screw (3), to check the correct tripping setting.
<b>1</b>	<div style="border: 1px solid black; padding: 5px; margin-bottom: 5px;"> <p><b>! NOTICE!</b></p> </div> <p><b>Check the pressure referring to the downstream pressure gauge of the equipment. If the slam-shut valve:</b></p> <ul style="list-style-type: none"> <li>• trips before the set pressure value, tighten (clockwise) the adjusting ring (13)</li> <li>• does not switch to the set pressure value, unscrew (anticlockwise) the adjustment ring nut (13).</li> </ul>
<b>2</b>	Reduce the pressure in the downstream section by opening the vent (6) to the regulator setting (1).
<b>3</b>	Restart the block by operating the control lever (16).
<b>4</b>	Repeat steps 1-2-3 at least three times for correct calibration

Tab. 8.62

**SPRING SETTING FOR MINIMUM PRESSURE TRIPPING (IF PRESENT)**

Step	Action
1	Open the atmospheric vent (6) and keep it open for the following steps.
2	Decrease the downstream pressure to the minimum pressure required to trigger the block by adjusting the pilot (3). <div style="border: 1px solid blue; padding: 5px; margin-top: 10px;">  <b>NOTICE!</b>  <b>Check the pressure referring to the downstream pressure gauge of the equipment.</b> </div>
3	Decrease the downstream pressure until the blockage is triggered by turning the pilot adjustment screw (3), to check the correct tripping setting. <div style="border: 1px solid blue; padding: 5px; margin-top: 10px;">  <b>NOTICE!</b>  <b>Check the pressure referring to the downstream pressure gauge of the equipment. If the slam-shut valve:</b> <ul style="list-style-type: none"> <li>• trips before the set pressure value, tighten (clockwise) the adjusting ring (15)</li> <li>• does not switch to the set pressure value, unscrew (anticlockwise) the adjustment ring nut (15).</li> </ul> </div>
4	Close the vent (6)
5	Restart the block by operating the control lever (16).
6	Re-open the vent (6).
7	Repeat steps 3-4-5-6 at least three times for correct calibration <div style="border: 1px solid blue; padding: 5px; margin-top: 10px;">  <b>NOTICE!</b>  <b>The calibration value must comply with the operating limits specified on the plate.</b> </div>

*Tab. 8.63*
**COMMISSIONING THE REGULATOR**

 **NOTICE!**

Please refer to “8.5 - Regulator commissioning procedure” of this chapter.

## 8.9 - COMMISSIONING PROCEDURE FOR APERFLUX 851 REGULATOR WITH INTEGRATED HB/97 SLAM SHUT VALVE

### 8.9.1 - CHECKING THE HB/97 INCORPORATED SLAM-SHUT VALVE FOR SEALING WHEN CLOSING

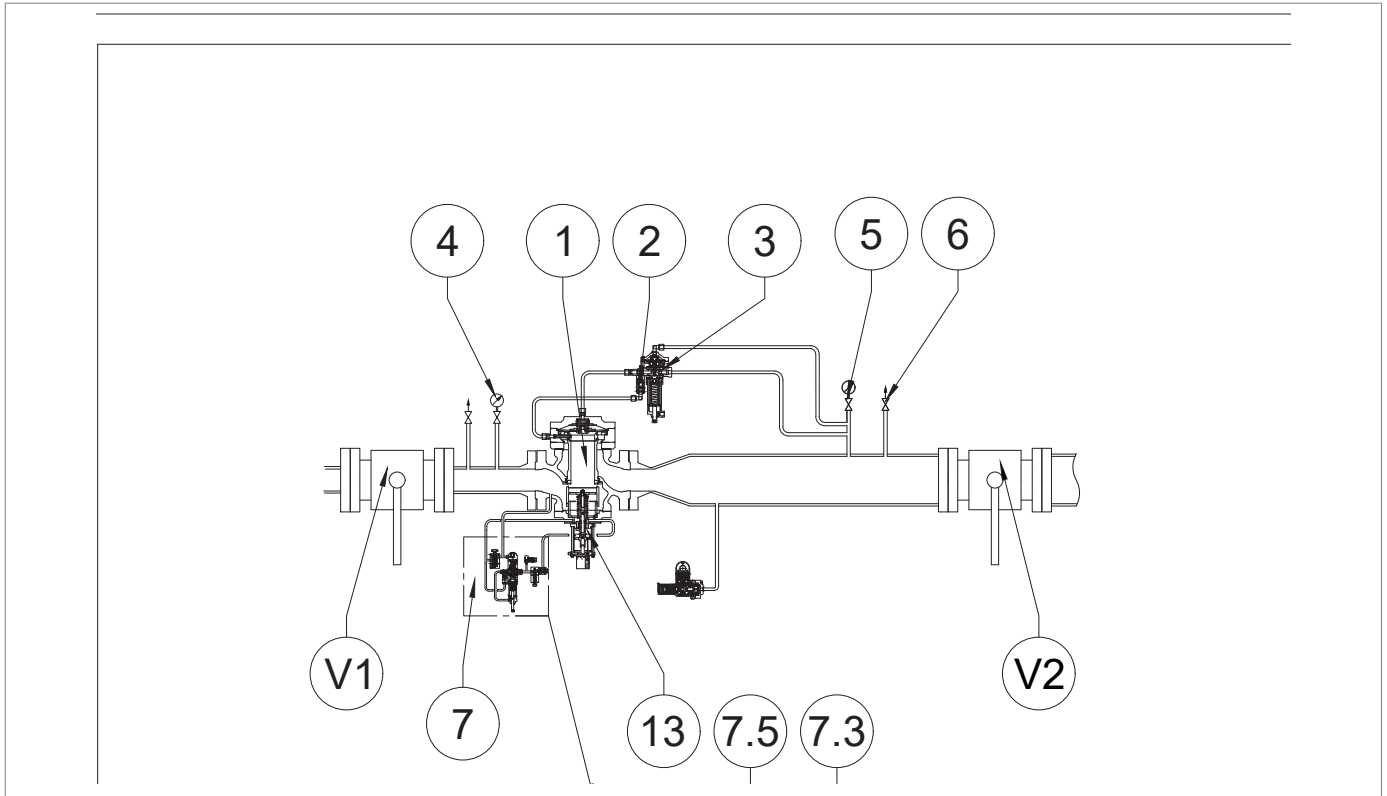

Fig. 8.30. Sealing of the HB/97 slam-shut valve when closing

Step	Action
1	Check that the built-in slam-shut valve is in the closed position.
2	Completely unscrew the fixing nut of the pilot screw (3).
3	Completely relieve the pilot spring (3) by turning the adjusting screw anti-clockwise.
4	Open the vent (6) and drain the downstream section completely.
5	Disconnect the tubing between the AR100 throttle valve (2) and the regulator head (1).
6	Reconnect the pipe between the AR100 throttle valve (2) and the regulator head (1). <div style="border: 1px solid black; padding: 5px; margin-top: 5px;"> <p><b>! NOTICE!</b>  <b>Check whether to replace the fitting by referring to the fitting manufacturer's instructions.</b></p> </div>
7	Check the tightness of the built-in slam shut valve with a foaming substance, through the connection connected to the regulator head. <div style="border: 1px solid black; padding: 5px; margin-top: 5px;"> <p><b>! NOTICE!</b>  <b>In case of leaks from the connection, see chapter "10 - Troubleshooting" to remove the causes of the dysfunction.</b></p> </div>

Tab. 8.64

**8.9.2 - LINE OFF 2.0 COMMISSIONING AND CALIBRATION PROCEDURE FOR HB/97 BUILT-IN SLAM-SHUT VALVE**

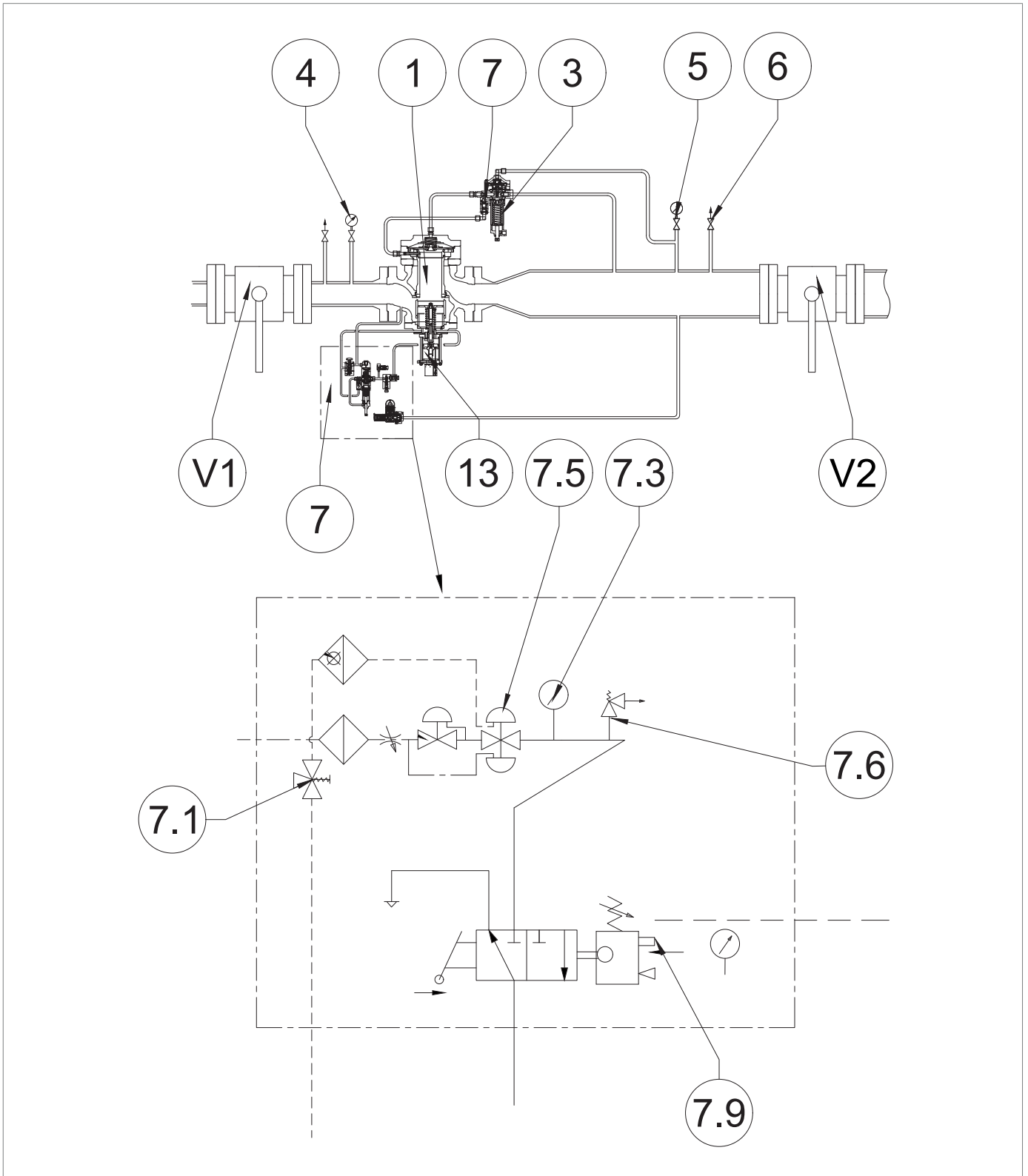



Fig. 8.31. LINE OFF 2.0 commissioning and calibration for the HB/97 built-in slam-shut valve

Step	Action
1	Completely unscrew the fixing nut of the pilot adjustment screw (3).
2	Completely relieve the pilot spring (3) by turning the adjusting screw anti-clockwise.
3	Press and hold the HP2/2 bypass device button (7.1) for: <ul style="list-style-type: none"> <li>• feed upstream pressure to the LINE-OFF 2.0 power unit (7);</li> <li>• balance the pressure of the HB/97 built-in slam-shut valve plug.</li> </ul>
4	Turn the adjusting screw of the R44/SS regulator (7.5) clockwise until the setting value of the VS/FI safety valve (7.6) is reached. <div style="border: 1px solid black; padding: 5px; margin-top: 10px;">  <b>NOTICE!</b>  <b>Check the pressure with reference to the pressure gauge</b> connected to regulator R44/SS (7.5). </div>
5	If the safety valve VS/FI (7.6): <ul style="list-style-type: none"> <li>• opens before the set pressure value: unscrew the shaft collar and screw (clockwise) the adjustment cap so as to compress the spring inside it more</li> <li>• does not open to the specified pressure value: unscrew the shaft collar and unscrew (anticlockwise) the adjustment cap, so as to release the spring inside.</li> </ul>
6	Slowly tighten the regulator setting screw R44/SS (7.5), by turning it clockwise, up to the cut-in pressure value of the safety valve VS/FI (7.6).
7	Decrease the outlet pressure of the R44/SS regulator (7.5) by unscrewing its adjusting screw and repeat step 6 at least three times for correct setting of the VS/FI safety valve (7.6).
8	Repeat step 6 at least three times for correct calibration of the VS/FI safety valve (7.6).
9	Calibrate the R44/SS regulator (7.5), using the adjustment screw, to the required pressure value by referring to the connected pressure gauge (7.3), then: <ul style="list-style-type: none"> <li>• tighten (clockwise) the adjustment screw so as to compress the spring inside it more, if the pressure value on the pressure gauge is lower than the setting value of the R44/SS regulator (7.5)</li> <li>• unscrew (anti-clockwise) the adjustment screw so as to release more of the spring inside it, if the pressure value on the pressure gauge is higher than the setting value of the R44/SS regulator (7.5).</li> </ul>
10	Arming the HB/97 built-in blocking valve by operating the lever (7.9).
11	Release the HP2/2 bypass device button (7.1).

Tab. 8.65

## COMMISSIONING THE REGULATOR

 **NOTICE!**

Please refer to “8.5 - Regulator commissioning procedure” of this chapter.

### 8.10 - CALIBRATION OF THE PRESSURE SWITCH FOR LINE OFF 2.0

 **NOTICE!**

For the pressure switch calibration procedure, please refer to “8.8.2 - Calibration procedure for pressure switches Models 02m/102mh ÷ 105m/105mh”.

## 8.11 - DEVICE CALIBRATION

### 8.11.1 - 200 SERIES AND 300 SERIES PILOTS

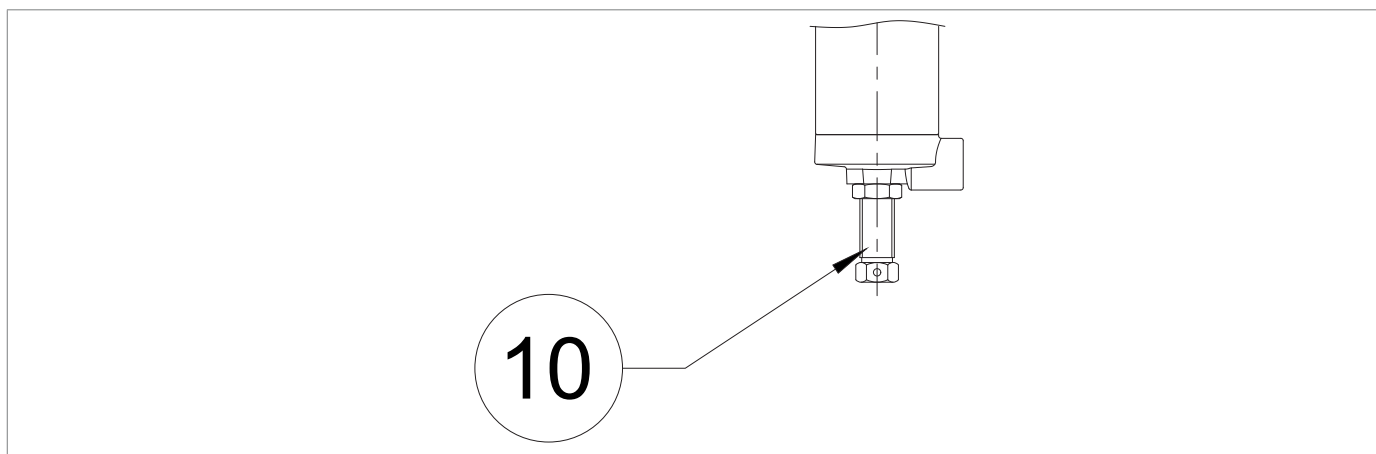

*Fig. 8.32. 200 series and 300 series pilots*

Turn the adjusting screw (10):

- anticlockwise to decrease the adjusted pressure;
- clockwise to increase the adjusted pressure.

### 8.11.2 - PRESSURE SWITCHES MODELS 102M/102MH - 105M/105MH

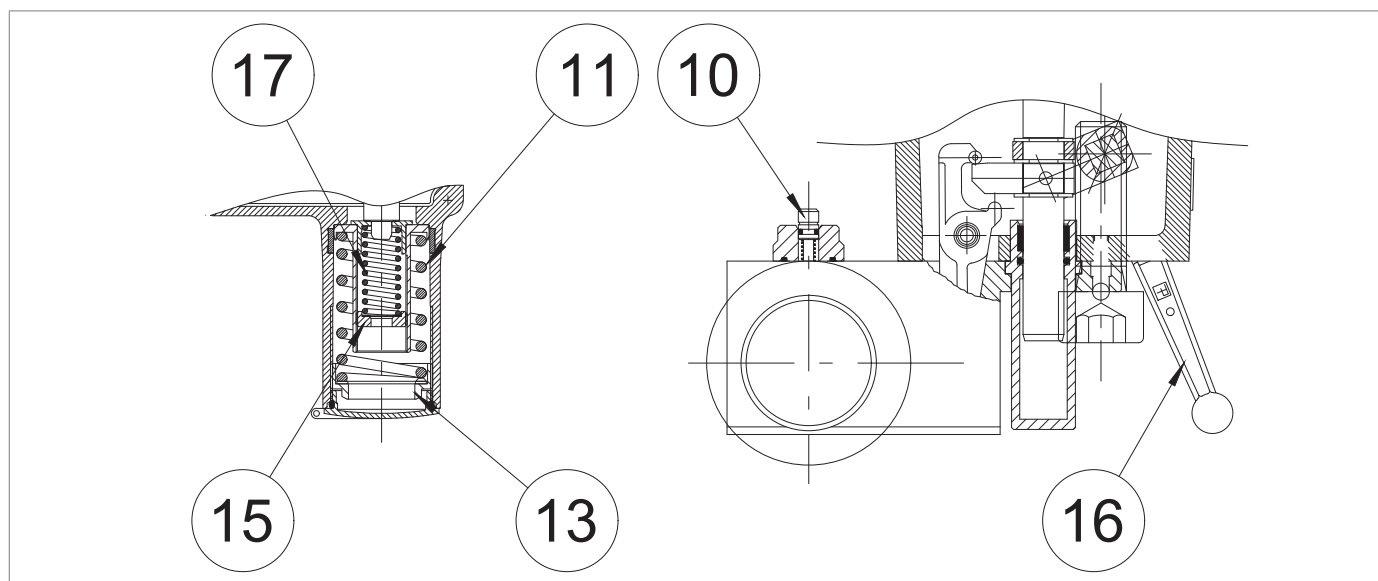

Fig. 8.33. Pressure switches models 102 to 105

Turn the max. ring nut (13):

- anti-clockwise to decrease the slam-shut device tripping pressure;
- clockwise to increase the slam-shut device tripping pressure.

Turn the min. ring nut (15):

- anti-clockwise to decrease the slam-shut device tripping pressure;
- clockwise to increase the slam-shut device tripping pressure.

**! NOTICE!**

**For calibration ranges, please refer to chapter "13 - Calibration tables".**

PAGE INTENTIONALLY LEFT BLANK

## 9 - MAINTENANCE AND FUNCTIONAL CHECKS

### 9.1 - GENERAL WARNINGS

#### HAZARD!

- Maintenance work must be carried out by qualified personnel trained on safety in the workplace and authorised to carry out equipment-related activities.
- Repair or maintenance work not provided for in this manual may be carried out only if approved by PIETRO FIORENTINI S.p.A.. No liability for personal injury or damage to property can be attributed to PIETRO FIORENTINI S.p.A. for work other than that described or performed in a manner other than indicated.

#### WARNING!

Before any intervention, it is necessary:

- to ensure that the line on which the equipment is installed is shut off upstream and downstream;
- to operate the slam shut valve in manual mode by pressing the release button (Pos. 10 - Figure 4.11.).  
Next, check that the pressure indicated by the pressure gauge installed on the LINE OFF 2.0 device (Pos. 7.3 - Figure 8.31.) is 0 bar, ensuring complete depressurisation of the line.

#### WARNING!

In case of doubt, do not perform any work. Contact PIETRO FIORENTINI S.p.A. for the necessary clarifications.

The management and/or use of the equipment includes interventions that are necessary as a result of normal use such as:

- inspection and checks;
- functional checks;
- routine maintenance;
- special maintenance.

#### NOTICE!

Maintenance work is strictly related to:

- the quality of the conveyed gas (impurities, humidity, gasoline, corrosive substances);
- the effectiveness of filtration;
- the conditions of use of the equipment.

To properly run the equipment, one should:

- follow the service frequency referred to in the manual for functional checks and routine maintenance.
- not exceed the time interval between one service and the next. The time interval is to be understood as the maximum acceptable; it can, however, be shortened;
- promptly check the causes of any anomalies such as excessive noise, leakage of fluids or similar and remedy them. The timely removal of any causes of anomaly and/or malfunction prevents further damage to the equipment and ensures operator safety;

Before beginning disassembly of the equipment, make sure that:

- the spare parts and parts used in replacements have adequate requirements to ensure the original performance of the equipment. Use recommended original spare parts;
- the operator must have the necessary equipment (see chapter “7 - Commissioning/maintenance equipment”).

 **NOTICE!**

**The recommended spare parts are unambiguously identified with tags indicating:**



- **the assembly drawing number of the equipment in which they are to be used (see chapter “12 - Recommended spare parts”);**
- **the position shown in the assembly drawing of the equipment.**

The equipment maintenance operations are divided, from an operational point of view, into three main categories:

Commissioning and maintenance operations	
<b>Periodic checks and inspections</b>	All those checks that the operator must carry out on a regular basis to ensure that the equipment is in proper working order.
<b>Routine maintenance</b>	<p>All those operations that the operator must preventively carry out to ensure proper operation of the device over time. Routine maintenance includes:</p> <ul style="list-style-type: none"> <li>• inspection;</li> <li>• control;</li> <li>• adjustment;</li> <li>• cleaning;</li> <li>• lubrication;</li> <li>• replacement;</li> </ul> <p>of all spare parts.</p>
<b>Special maintenance</b>	<p>All those operations to be carried out by the operator when the equipment requires them.</p> <div style="background-color: #c00000; color: white; padding: 5px; display: flex; align-items: center;">  <b>HAZARD!</b> </div> <p><b>Special maintenance:</b></p> <ul style="list-style-type: none"> <li>• <b>requires extensive and specialised knowledge of the machines, operations required, risks involved and correct procedures to operate safely;</b></li> <li>• <b>must be provided by qualified, trained and authorised technicians.</b></li> </ul>

Tab. 9.66

## 9.2 - PERIODICALLY CHECKING AND INSPECTING THE EQUIPMENT FOR PROPER OPERATION

Periodic checks and inspections	
<b>Operator qualification</b>	Mechanical maintenance technician
<b>PPE required</b>	 <div style="background-color: orange; padding: 5px; margin-top: 10px;">  <b>WARNING!</b> </div> <p>The PPE listed in this table is related to the risk associated with the equipment. For the required PPE to protect against risks associated with the workplace, installation or operating conditions, please refer to:</p> <ul style="list-style-type: none"> <li>the regulations in force in the country of installation;</li> <li>any information provided by the Safety Manager at the installation facility.</li> </ul>

Tab. 9.67

Checks and inspections are operations that do not require any manual service on the equipment. Some items thereof can be replaced remotely using suitable remote control tools. The following is listed below:

Activity description	Equipment/accessories involved	Evaluation criterion	Minimum frequency
<b>Control of significant performance*</b>	Pressure regulators	<ul style="list-style-type: none"> <li>No fluctuations in the adjusted pressure.</li> <li>Significant pressure values within pre-set limits.</li> </ul>	Monthly
	Gas flow slam-shut type safety devices (external position indicator)	<ul style="list-style-type: none"> <li>Fully open position.</li> </ul>	
	Stand-by monitor (external position indicator)	<ul style="list-style-type: none"> <li>Fully open position.</li> </ul>	
<b>Visual inspection of external status of the equipment</b>	All	<ul style="list-style-type: none"> <li>No visible damage.</li> <li>External surface protection as per UNI 9571-1:2012.</li> </ul>	Half-yearly

Tab. 9.68

\* These checks may be carried out remotely if there is a remote control system capable of analysing the significant performance of the equipment and of sending alerts/alarms when pre-set thresholds are reached.

## 9.3 - ROUTINE MAINTENANCE

### 9.3.1 - GENERAL SAFETY WARNINGS

#### **HAZARD!**

- Put the equipment in a safe condition (close the downstream and then the upstream shut-off valve, drain the equipment completely and lastly drain the line);
- Ensure that the pressure upstream and downstream of the equipment is 0.

#### **WARNING!**

Before any intervention, it is necessary:

- to ensure that the line on which the equipment is installed is shut off upstream and downstream;
  - to operate the slam shut valve in manual mode by pressing the release button (Pos. 10 - Figure 4.11.).
- Next, check that the pressure indicated by the pressure gauge installed on the LINE OFF 2.0 device (Pos. 7.3 - Figure 8.31.) is 0 bar, ensuring complete depressurisation of the line.

#### **NOTICE!**

Before installing new sealing elements (o-rings, diaphragm, etc.), their integrity must be checked.

### 9.3.2 - REPLACEMENT FREQUENCY FOR COMPONENTS SUBJECT TO WEAR

**! NOTICE!**

The following provisions shall apply to equipment components only.

The non-metallic parts of the equipment concerned are divided into the following two categories:

**Preventive maintenance work**

<b>Category 1</b>	Covers parts subject to wear and/or abrasion, where: <ul style="list-style-type: none"> <li>wear and tear means the normal degradation of a part after prolonged use under normal operating conditions;</li> <li>abrasion is the mechanical action on the surface of the affected part resulting from the passage of gas under normal operating conditions.</li> </ul>
<b>Category 2</b>	takes into account parts subject to aging only, including parts that also require lubrication and/or cleaning.

Tab. 9.69

**! NOTICE!**





Check, within the minimum frequency specified in “Tab. 9.70”, the available components for wear/abrasion/aging.

Category	Part description	Evaluation criterion	Minimum replacement frequency
<b>1</b>	Valve seat sealing rings and non-metallic plugs	Pressure regulators	6 years
		Safety devices	
		Pressure safety system equipment	
<b>1</b>	Non-metallic parts with internal sealing function of valve seats and accessories of individual equipment	Pilots	6 years
		Pre-regulators	
		Accelerators	
		Any others	
<b>1</b>	Non-metallic parts with a sealing function between parts, at least one of which is in motion under normal working/operating conditions	Pressure regulators	6 years
		Gas flow slam-shut type safety devices	
		Relief devices with discharge to atmosphere	
<b>1</b>	Non-metallic parts with sealing function involved in disassembly operations during maintenance	Equipment subject to maintenance	6 years
<b>2</b>	Non-metallic parts providing feedback (sensing elements) of the controlled pressure of safety equipment.	Safety equipment and/or accessories	6 years
<b>2</b>	Non-metallic parts with sealing and performance functions (diaphragms) of equipment	Pressure regulators and accessories	6 years
		Gas flow slam-shut type safety devices	6 years
		Relief device with discharge to atmosphere	6 years
<b>2</b>	Non-metallic parts of equipment with an internal sealing function: under normal operating conditions during maintenance	Relief valves	6 years
		Regulation lines disconnection equipment	In the presence of ascertained leaks

Category	Part description	Evaluation criterion	Minimum replacement frequency
2	Non-metallic parts with a static sealing function only	Various equipment	In the presence of ascertained leaks
2	Lubricating parts	Shut-off valves	Yearly
		Other equipment	Yearly
2	Filter elements	Filters	As needed

Tab. 9.70

## 9.4 - ROUTINE MAINTENANCE PROCEDURES

Routine maintenance	
<b>Operator qualification</b>	Mechanical maintenance technician
<b>PPE required</b>	<div style="display: flex; justify-content: space-around; align-items: center;">      </div> <div style="background-color: #f4a460; padding: 5px; margin-top: 5px;"> <b>⚠ WARNING!</b> </div> <p>The PPE listed in this table is related to the risk associated with the equipment. For the required PPE to protect against risks associated with the workplace, installation or operating conditions, please refer to:</p> <ul style="list-style-type: none"> <li>the regulations in force in the country of installation;</li> <li><u>any information provided by the Safety Manager at the installation facility.</u></li> </ul>
<b>Equipment required</b>	Please refer to the chapter “7 - Commissioning/maintenance equipment”.

Tab. 9.71

**9.4.1 - TIGHTENING TORQUES APERFLUX 851**

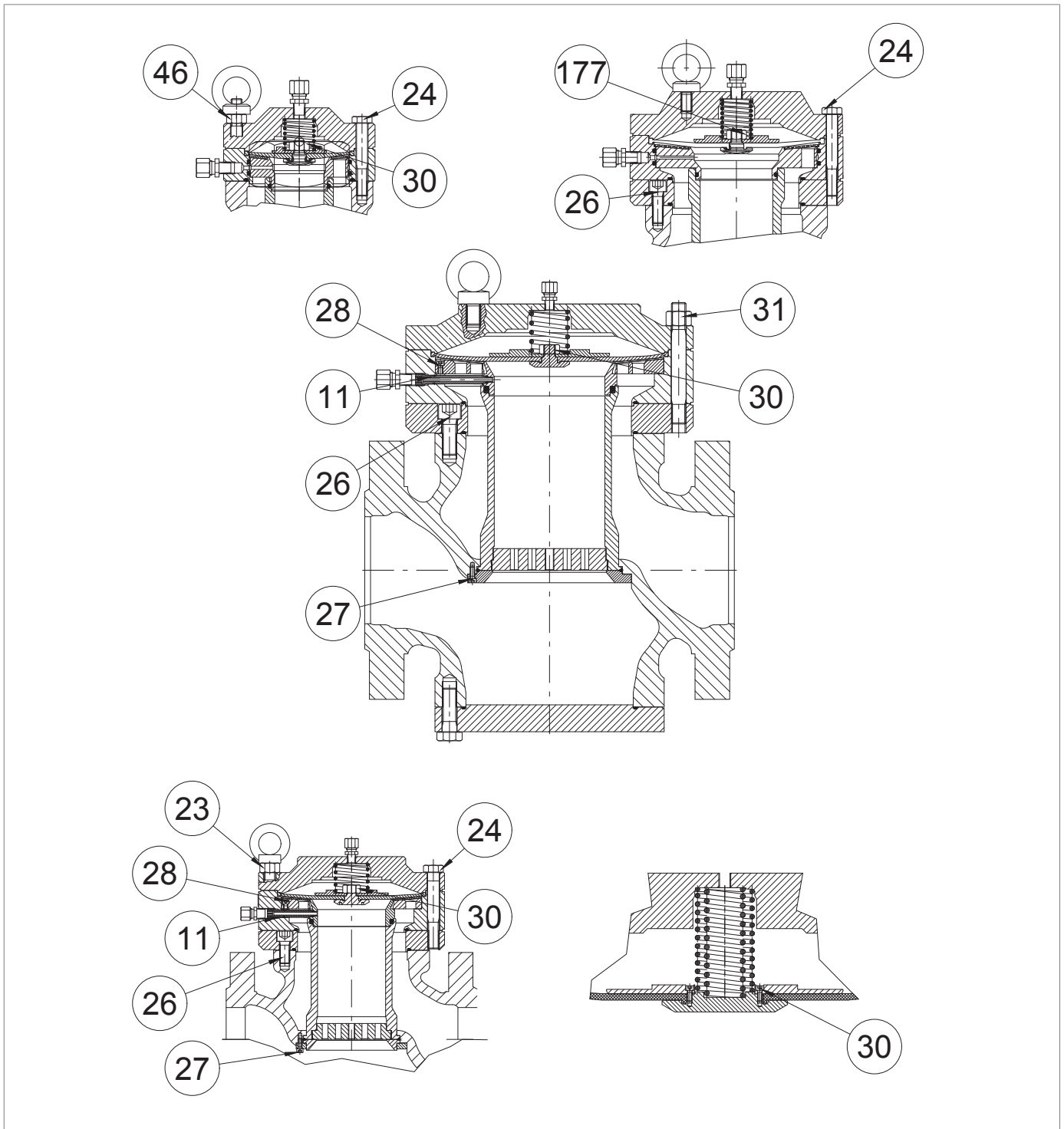

Fig. 9.34. Tightening torques APERFLUX 851

**APERFLUX 851 1"**

Pos.	Description	Torque (nm)	Torque (ft - lb)
24	Screw M10X80 UNI 5939	45	33
25	Screw M10X30 UNI 5739	45	33
27	Screw M6X12 UNI 5931	10	7
30	Nut M12 UNI 5588	50	36
46	Nut M10 UNI 5588	45	33

*Tab. 9.72*
**APERFLUX 851 2"**

Pos.	Description	Torque (nm)	Torque (ft - lb)
24	Screw M12X80 UNI 5937	80	59
25	Screw M12X35 UNI 5739	80	59
27	Screw M6X12 UNI 5931	10	7
30	Nut M12X1.25 UNI 5588	50	36
46	Nut M12 UNI 5588	80	59

*Tab. 9.73*
**APERFLUX 851 3"**

Pos.	Description	Torque (nm)	Torque (ft - lb)
24	Screw M12X90 UNI 5939	80	59
25	Screw M12X40 UNI 5739	80	59
26	Screw M12X40 UNI 5931	80	59
27	Screw M6X16 UNI 5931	10	7
30	Nut M12X1.25 UNI 5588	50	36

*Tab. 9.74*
**APERFLUX 851 4"**

Pos.	Description	Torque (nm)	Torque (ft - lb)
11	Aperflux connection	5	3
23	Nut M18 UNI 5588	200	147
24	Screw M18X120 UNI 5937	200	147
25	Screw M16X50 UNI 5737	150	110
26	Screw M16X35 UNI 5931	150	110
27	Screw M16X16 UNI 5931	10	7
28	Screw M6X16 UNI 5931	10	7
30	Nut M16 UNI 5588	80	59

*Tab. 9.75*

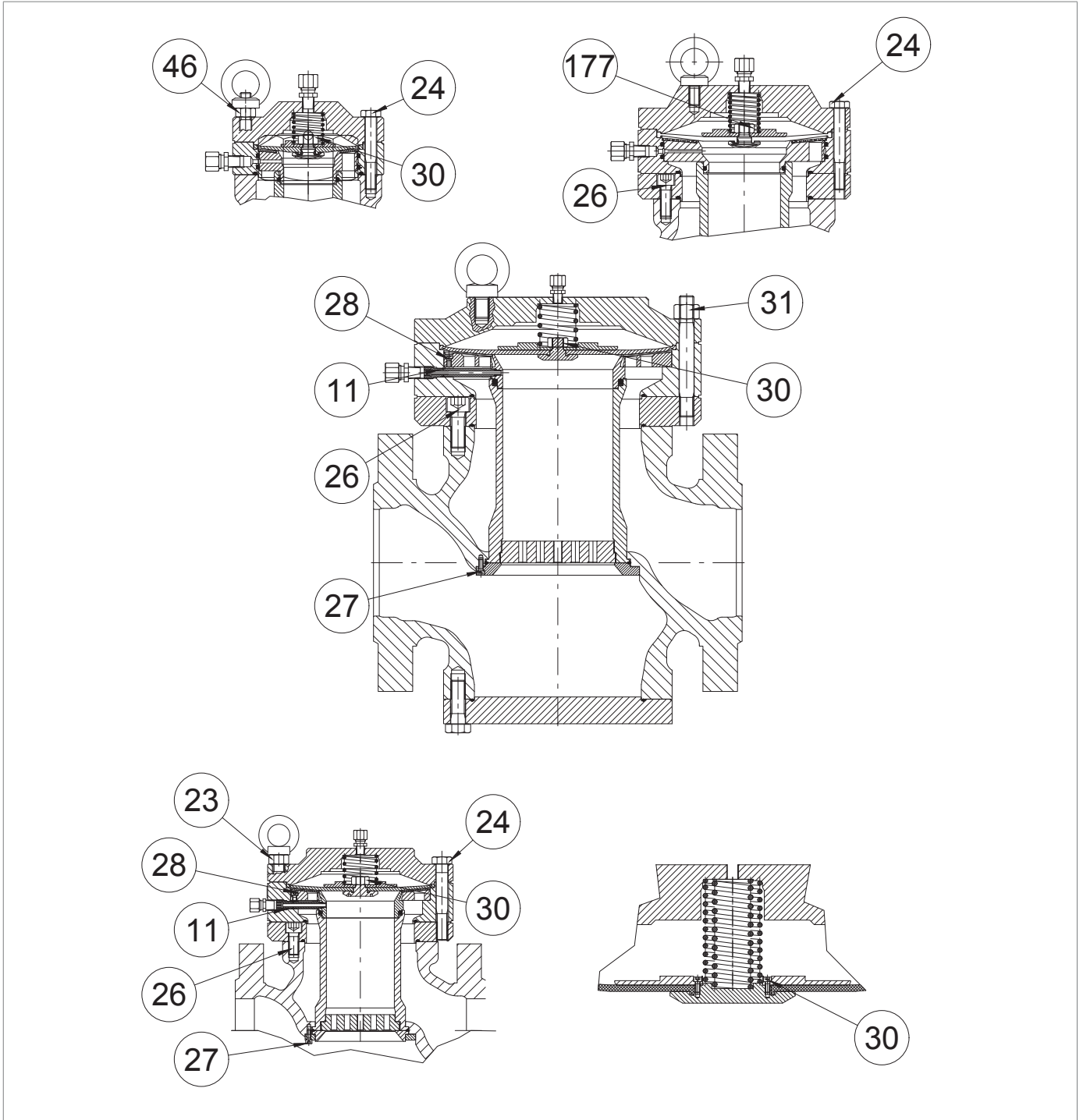

*Tightening torques APERFLUX 851*

**APERFLUX 851 6"**

Pos.	Description	Torque (nm)	Torque (ft - lb)
11	Aperflux connection	5	3
25	Screw M20X60 UNI 5737	150	110
26	Screw M20X50 UNI 5931	280	206
27	Screw M6X16 UNI 5931	10	7
28	Screw M6X20 UNI 5931	10	7
28	Screw M6X25 UNI 5931	10	7
30	Nut M16 UNI 5588	80	59
31	Nut M20 UNI 5587	250	184

*Tab. 9.76*
**APERFLUX 851 8"**

Pos.	Description	Torque (nm)	Torque (ft - lb)
11	Aperflux connection	5	3
25	Screw M22X70 UNI 5737	280	206
26	Screw M22X80 UNI 5931	280	206
27	Screw M6X16 UNI 5931	10	7
28	Screw M6X25 UNI 5931	10	7
30	Nut M16 UNI 5588	80	59
31	Nut M24 UNI 5587	300	221

*Tab. 9.77*
**APERFLUX 851 10"**

Pos.	Description	Torque (nm)	Torque (ft - lb)
25	Screw M22X90 UNI 5737	280	206
26	Screw M22X70 UNI 5931	280	206
27	Screw M6X16 UNI 5931	10	7
28	Screw M6X25 UNI 5931	10	7
30	Screw M5x12 UNI 5931	6	4
31	Nut M24 UNI 5587	300	221

*Tab. 9.78*

**9.4.1.1 - TIGHTENING TORQUES FOR PILOTS SERIES 300**

Fig. 9.35. Tightening torques for 302/A pilot

PILOT 302/A			
Pos.	Description	Torque (nm)	Torque (ft - lb)
2	Nut M16X1	20	14
23	Screw M8X30 UNI 5931 AISI	20	14
24	Screw M8X25 UNI 5931 AISI	20	14
24.1	Screw M8X30 UNI 5931 AISI	20	14
25	Nut M16X1.5	20	14
26	Nut M18X1.5	20	14
44	Nut M20X1	8	5

Tab. 9.79

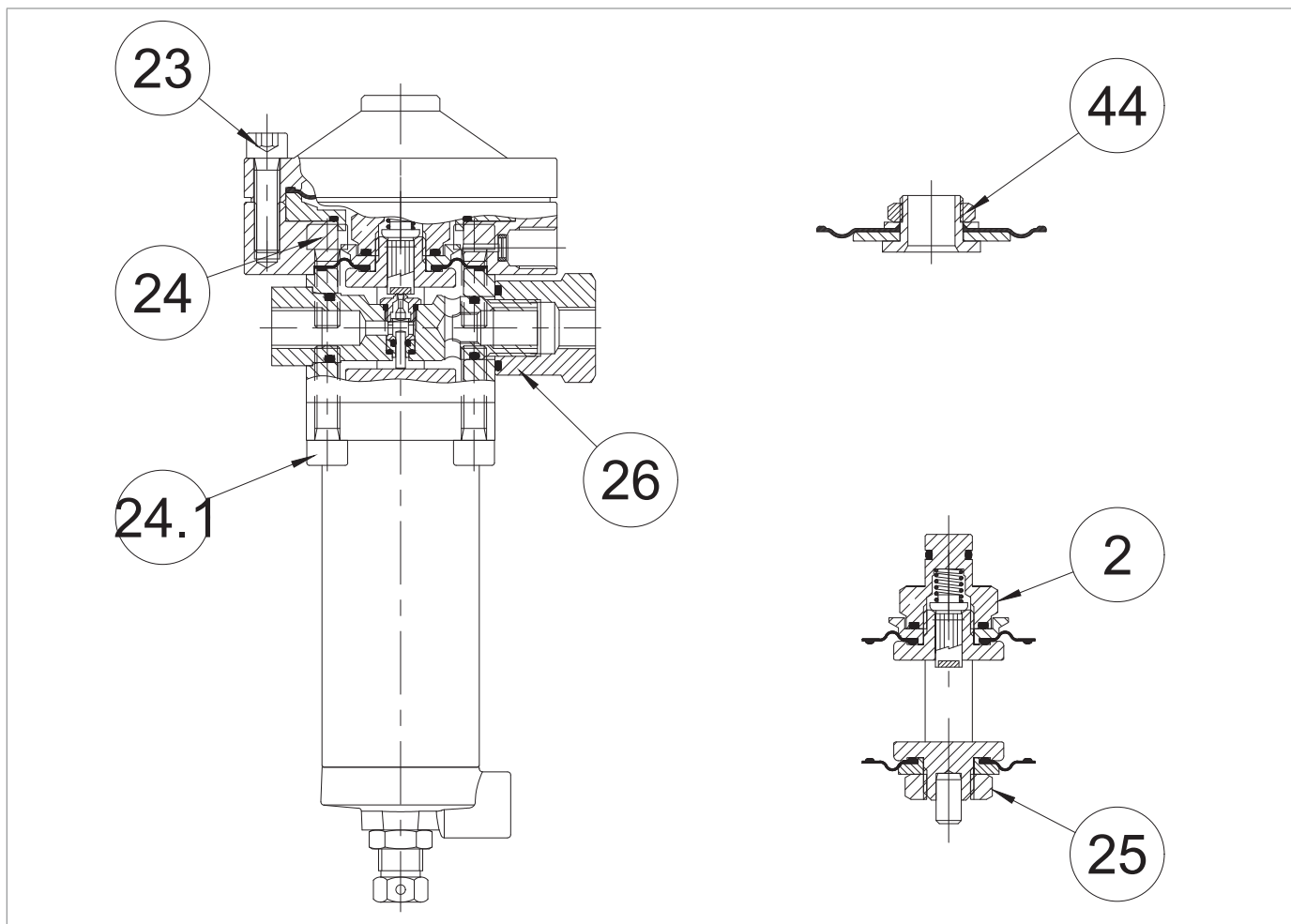
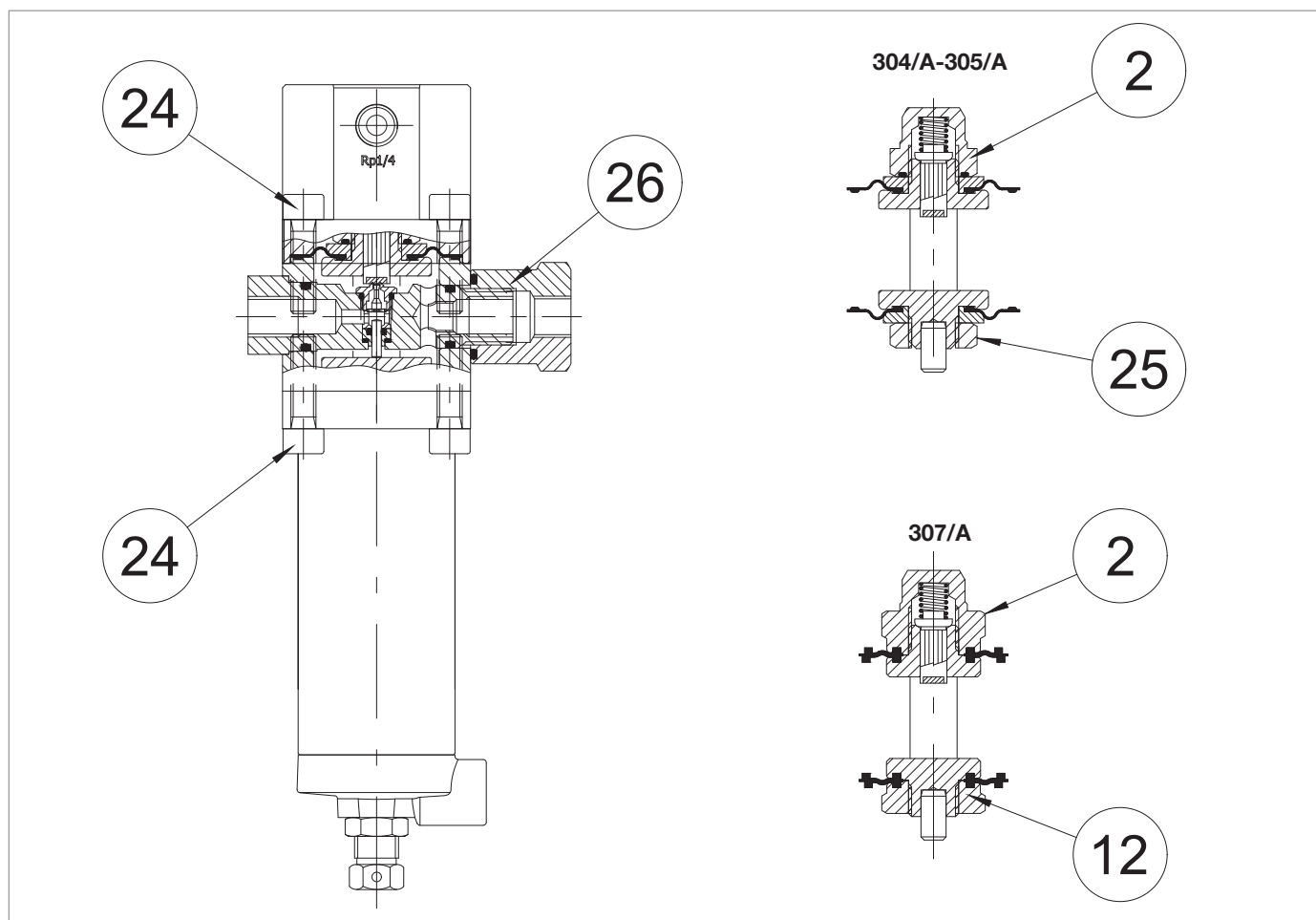

Fig. 9.36. Tightening torques for 304/A-305/A-307/A pilots

PILOTS 304/A-305/A-307/A			
Pos.	Description	Torque (nm)	Torque (ft - lb)
2	Nut M16X1	20	14
12	Nut M16X1.5	20	14
24	Screw M8X30 UNI 5931 AISI	16	11
25	Nut M16X1.5	20	14
26	Nut M18X1.5	20	14

Tab. 9.80

**9.4.1.2 - TIGHTENING TORQUES FOR THROTTLE VALVE AR100**

Fig. 9.37. Tightening torques for throttle valve AR100

<b>LAMINATION VALVE AR100</b>			
<b>Pos.</b>	<b>Description</b>	<b>Torque (nm)</b>	<b>Torque (ft - lb)</b>
2	Cap M20X1.5	20	14
4	Screw M8 AISI	4	2

Tab. 9.81

PAGE INTENTIONALLY LEFT BLANK

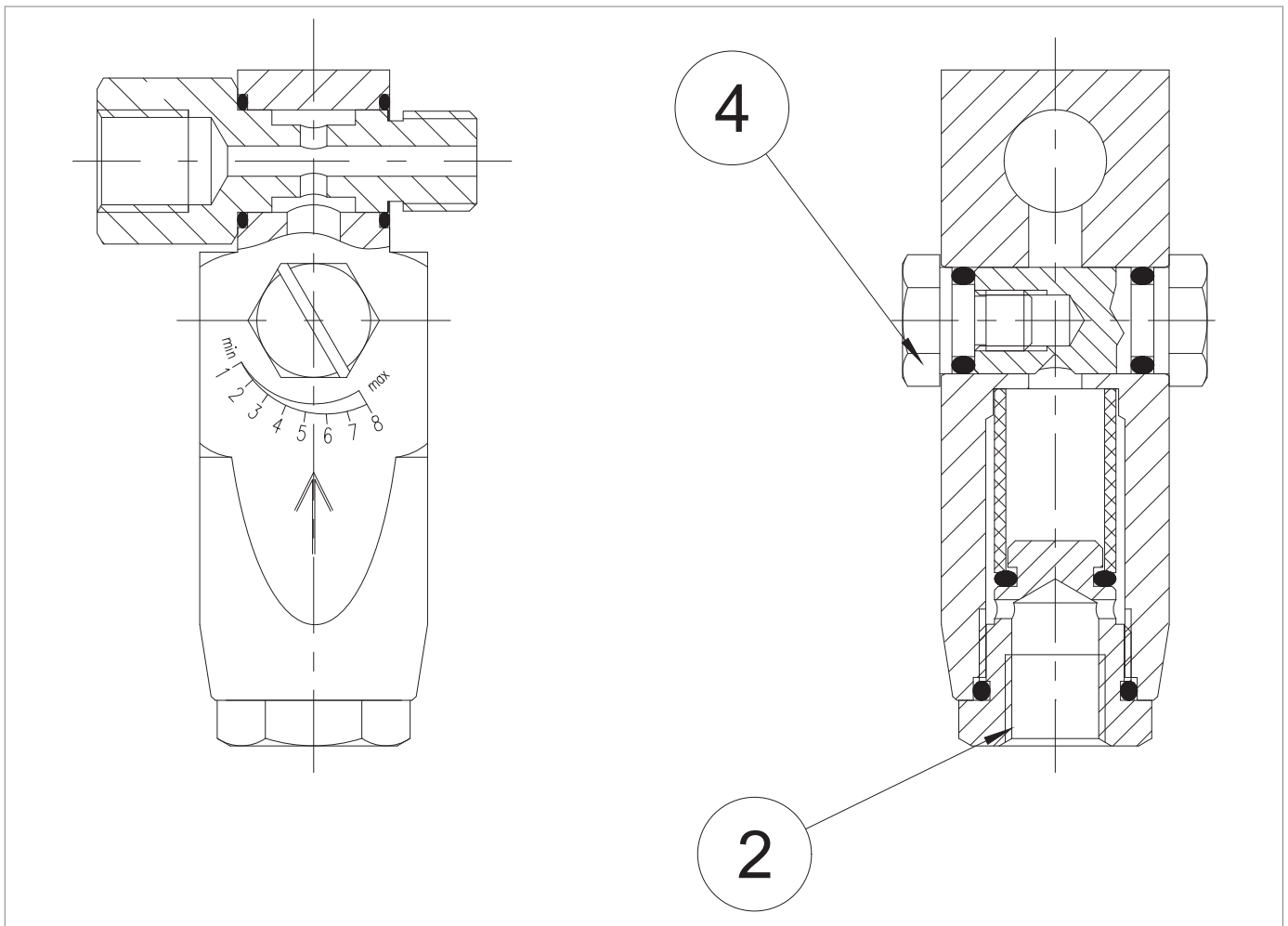
9.4.1.3 - TIGHTENING TORQUES APERFLUX 851 + SILENCER DB/851

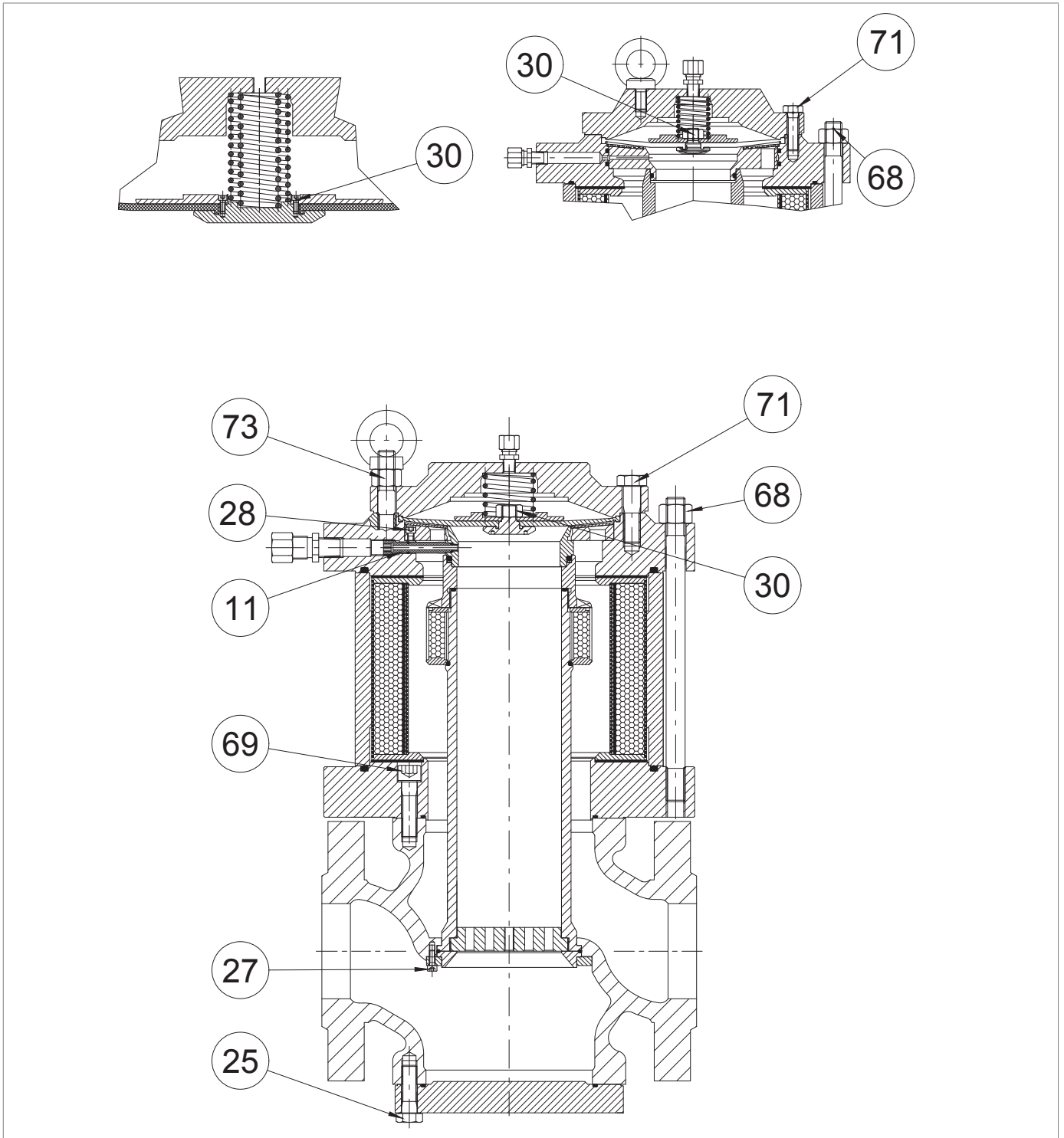

Fig. 9.38. Tightening torques APERFLUX 851 + Silencer DB/851

**APERFLUX 851 1" + DB/851**

Pos.	Description	Torque (nm)	Torque (ft - lb)
25	Screw M10X30 UNI 5739	45	33
27	Screw M6X12 UNI 5931	10	7
30	Nut M12 UNI 5588	50	36
69	Screw M10X35 UNI 5931	45	33
68	Nut M14 UNI 5588	115	84
71	Screw M10X45 UNI 5939	45	33

*Tab. 9.82*
**APERFLUX 851 2" + DB/851**

Pos.	Description	Torque (nm)	Torque (ft - lb)
25	Screw M12X35 UNI 5739	80	59
27	Screw M6X12 UNI 5931	10	7
30	Nut M12 UNI 5588	50	36
68	Nut M18 UNI 5588	200	147
69	Screw M12X45 UNI 5931	80	59
71	Screw M12X40 UNI 5939	80	59

*Tab. 9.83*
**APERFLUX 851 3" + DB/851**

Pos.	Description	Torque (nm)	Torque (ft - lb)
25	Screw M12X40 UNI 5739	80	59
27	Screw M6X16 UNI 5931	10	7
30	Nut M12 UNI 5588	50	36
68	Nut M18 UNI 5588	200	147
69	Screw M12X45 UNI 5931	80	59
71	Screw M12X45 UNI 5939	80	59

*Tab. 9.84*
**APERFLUX 851 4" + DB/851**

Pos.	Description	Torque (nm)	Torque (ft - lb)
11	Aperflux connection	5	3
25	Screw M16X50 UNI 5737	150	110
27	Screw M16X16 UNI 5931	10	7
28	Screw M6X16 UNI 5931	10	7
30	Nut M16 UNI 5588	80	59
68	Nut M20 UNI 5588	250	184
69	Screw M16X60 UNI 5931	200	147
71	Screw M18X60 UNI 5937	200	147
73	Nut M18 UNI 5587	200	147

*Tab. 9.85*

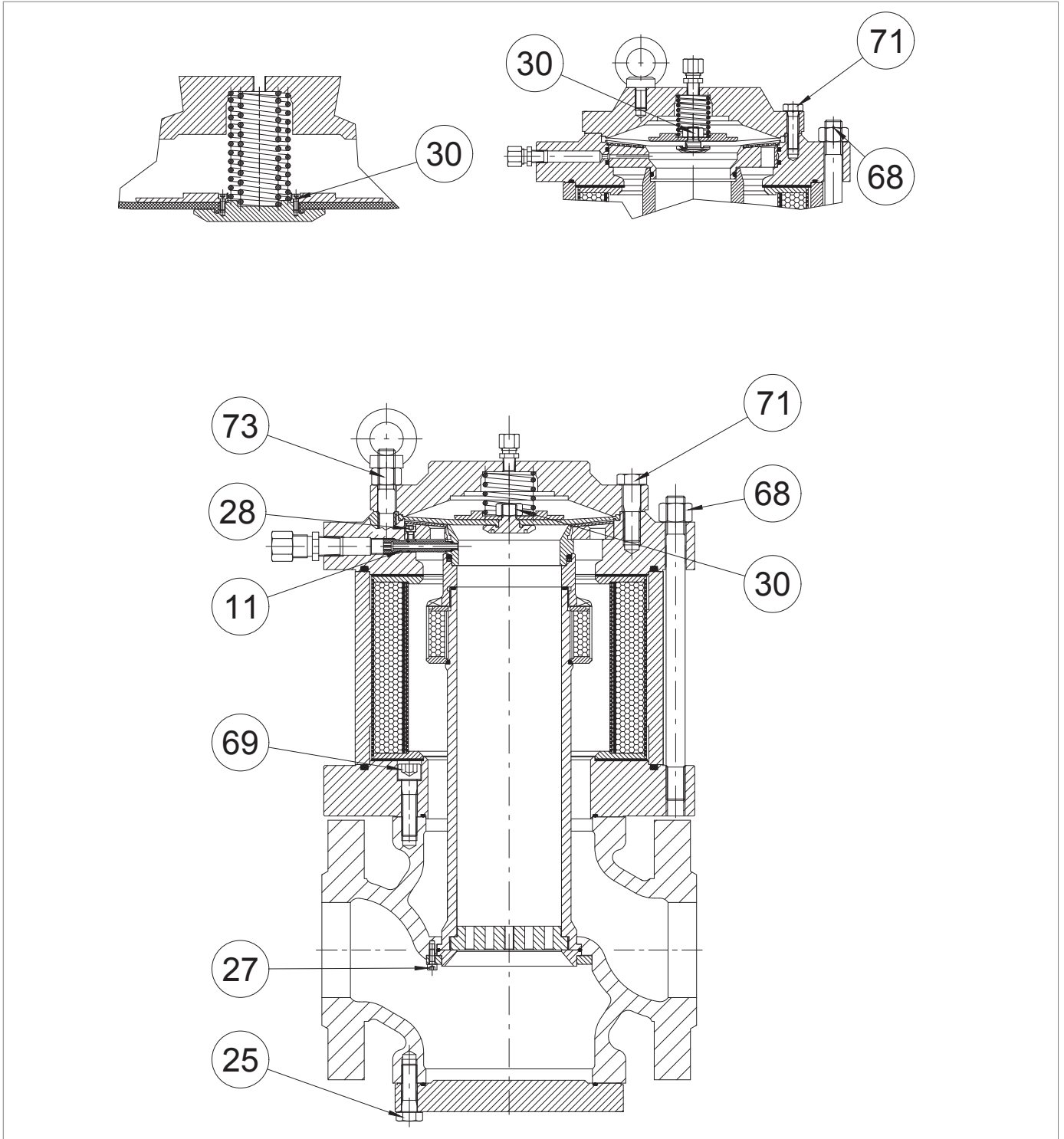

*Tightening torques APERFLUX 851 + Silencer DB/851*

**APERFLUX 851 6" + DB/851**

Pos.	Description	Torque (nm)	Torque (ft - lb)
11	Aperflux connection	5	3
25	Screw M20X60 UNI 5737	150	110
27	Screw M6X16 UNI 5931	10	7
28	Screw M6X20 UNI 5931	10	7
30	Nut M16 UNI 5588	80	59
68	Nut M22 UNI 5588	280	206
69	Screw M20X70 UNI 5931	400	295
71	Screw M20X60 UNI 5737	250	184

*Tab. 9.86*
**APERFLUX 851 8" + DB/851**

Pos.	Description	Torque (nm)	Torque (ft - lb)
11	Aperflux connection	5	3
25	Screw M22X70 UNI 5737	280	206
27	Screw M6X16 UNI 5931	10	7
28	Screw M6X25 UNI 5931	10	7
30	Nut M16 UNI 5588	80	59
68	Nut M24 UNI 5587	300	221
69	Screw M22X80 UNI 5931	500	368
71	Screw M24X90 UNI 5937	300	221

*Tab. 9.87*
**APERFLUX 851 10" + DB/851**

Pos.	Description	Torque (nm)	Torque (ft - lb)
25	Screw M22X90 UNI 5737	280	206
27	Screw M6X16 UNI 5931	10	7
28	Screw M6X25 UNI 5931	10	7
30	Screw M5x12 UNI 5931	6	4
68	Nut M24 UNI 5587	300	221
69	Screw M22X110 UNI 5931	280	206
71	Screw M24X90 UNI 5937	300	221

*Tab. 9.88*

#### 9.4.1.4 - TIGHTENING TORQUES FOR PM/819 BUILT-IN MONITOR

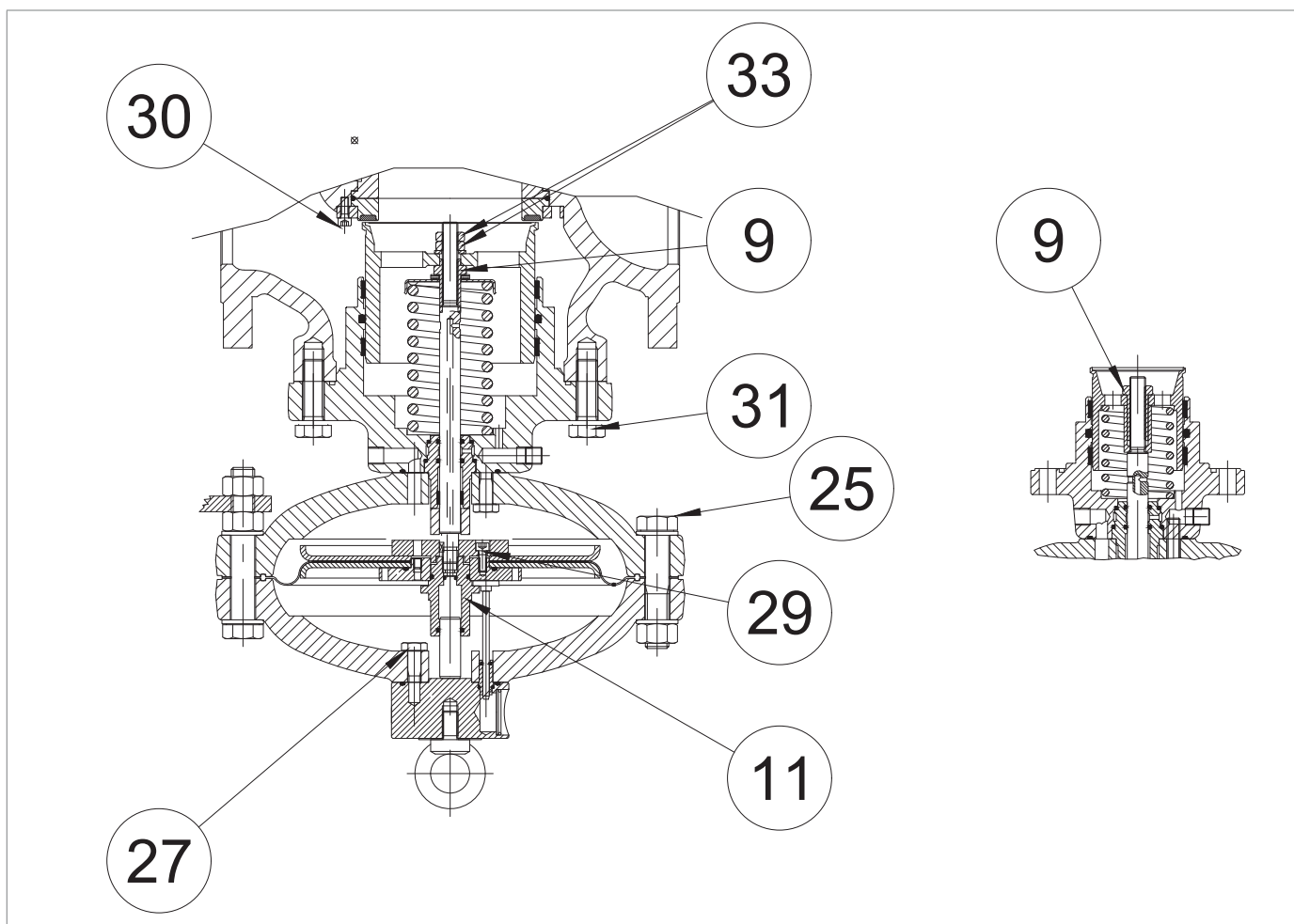

Fig. 9.39. Tightening torques for PM/819 built-in monitor

PM/819 1"			
Pos.	Description	Torque (nm)	Torque (ft - lb)
9	Nut M12	35	25
11	M12 balancing piston guide	35	25
25	Screw M16X70 UNI 5737	60	44
27	Screw M10X35 5739	45	33
29	Screw M6X14 UNI 5931	10	7
30	Screw M6X12 UNI 5931	10	7
31	Screw M10X30 UNI 5739	45	33

Tab. 9.89

**PM/819 2"**

Pos.	Description	Torque (nm)	Torque (ft - lb)
9	Nut M12	35	25
11	M12 balancing piston guide	35	25
25	Screw M16X70 UNI 5737	60	44
27	Screw M10X35 5739	45	33
29	Screw M6X14 UNI 5931	10	7
30	Screw M6X12 UNI 5931	10	7
31	Screw M12X35 UNI 5739	80	59

*Tab. 9.90*
**PM/819 3"**

Pos.	Description	Torque (nm)	Torque (ft - lb)
9	Nut M12	35	25
11	M12 balancing piston guide	35	25
25	Screw M18X90 UNI 5737	70	51
27	Screw M10X40 UNI 5737	45	33
29	Screw M6X14 UNI 5931	10	7
30	Screw M6X16 UNI 5931	10	7
31	Screw M12X40 UNI 5739	80	59
33	Nut M12 UNI 5589	35	25

*Tab. 9.91*
**PM/819 4"**

Pos.	Description	Torque (nm)	Torque (ft - lb)
9	Nut M12	35	25
11	M12 piston guide	35	25
25	Screw M18X90 UNI 5737	70	51
27	Screw M10X40 UNI 5737	45	33
29	Screw M6X14 UNI 5931	10	7
30	Screw M6X16 UNI 5931	10	7
31	Screw M16X50 UNI 5737	150	110
33	Nut M12 UNI 5589	35	25

*Tab. 9.92*

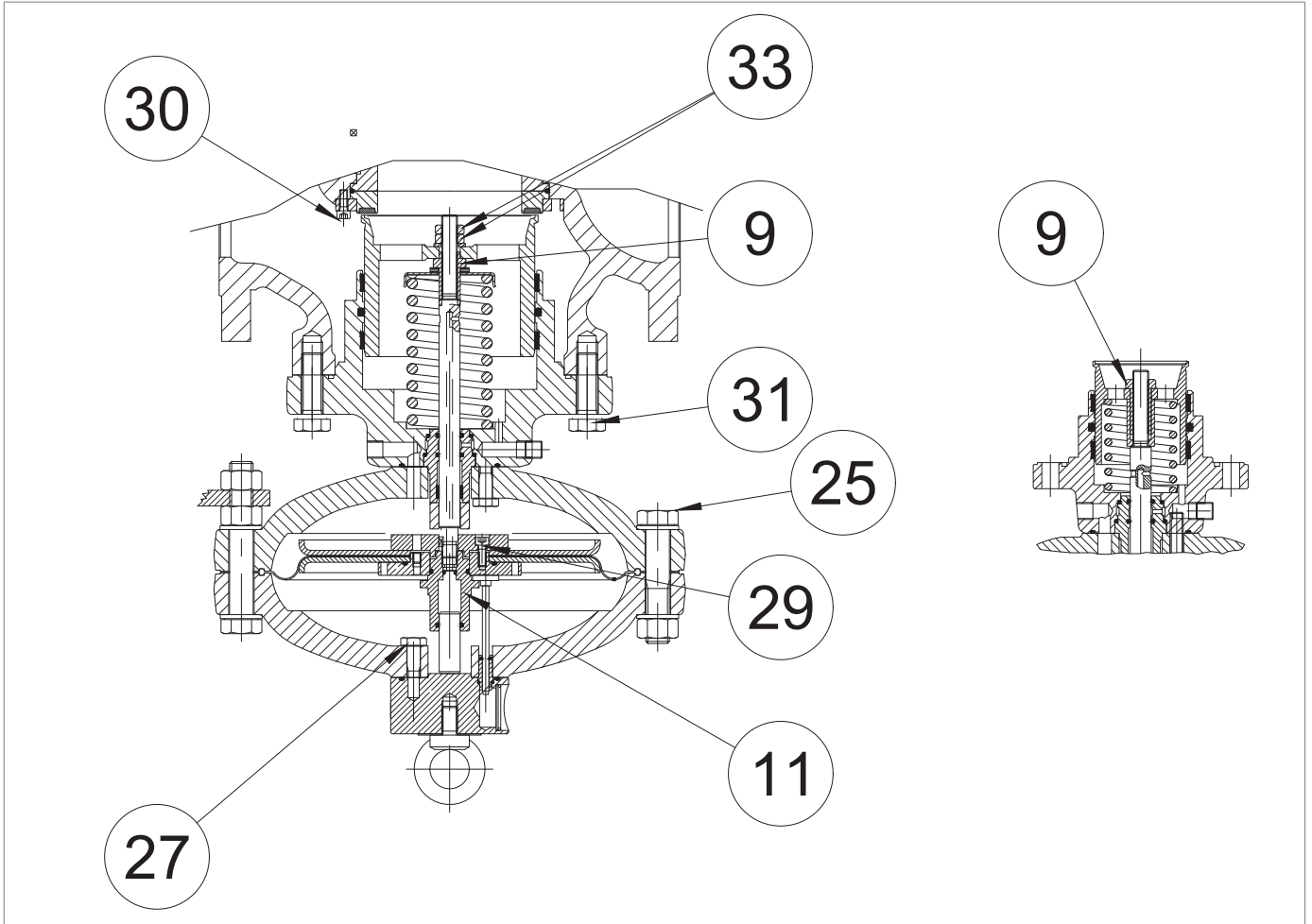

*Tightening torques for PM/819 built-in monitor*

**PM/819 6"**

Pos.	Description	Torque (nm)	Torque (ft - lb)
9	Nut M24	110	81
11	M18 balancing piston guide	110	81
25	Screw M22X120 UNI 5737	100	73
27	Screw M14X50 UNI 5737	115	84
29	Screw M6X16 UNI 5931	10	7
30	Screw M6X16 UNI 5931	10	7
31	Screw M20X60 UNI 5737	250	184
33	Nut M18 UNI 5589	110	81

*Tab. 9.93*
**PM/819 8"**

Pos.	Description	Torque (nm)	Torque (ft - lb)
9	Nut M24	110	81
11	M18 balancing piston guide	110	81
25	Screw M22X120 UNI 5737	100	73
27	Screw M14X50 UNI 5737	115	84
29	Screw M6X16 UNI 5931	10	7
30	Screw M6X16 UNI 5931	10	7
31	Screw M22X70 UNI 5737	280	206
33	Nut M18 UNI 5589	110	81

*Tab. 9.94*
**PM/819 10"**

Pos.	Description	Torque (nm)	Torque (ft - lb)
9	Nut M30	150	110
11	M18 balancing piston guide	150	110
25	Screw M27X150 UNI 5737	220	162
27	Screw M20X80 UNI 5737	250	184
29	Screw M6X16 UNI 5737	10	7
30	Screw M6X16 UNI 5931	10	7
31	Screw M22X70 UNI 5737	280	206
33	Nut M20 UNI 5589	150	110

*Tab. 9.95*

**9.4.1.5 - TIGHTENING TORQUES FOR PILOTS SERIES 200**

Fig. 9.40. Tightening torques for 204/A-205/A-207/A pilots

**PILOTS 204/A-205/A**

Pos.	Description	Torque (nm)	Torque (ft - lb)
2	Nut M16X1	25	18
24	Screw M8X30 UNI 5931 AISI	20	14
25	Nut M16X1.5	25	18
26	Nut M18X1.5	20	14

Tab. 9.96

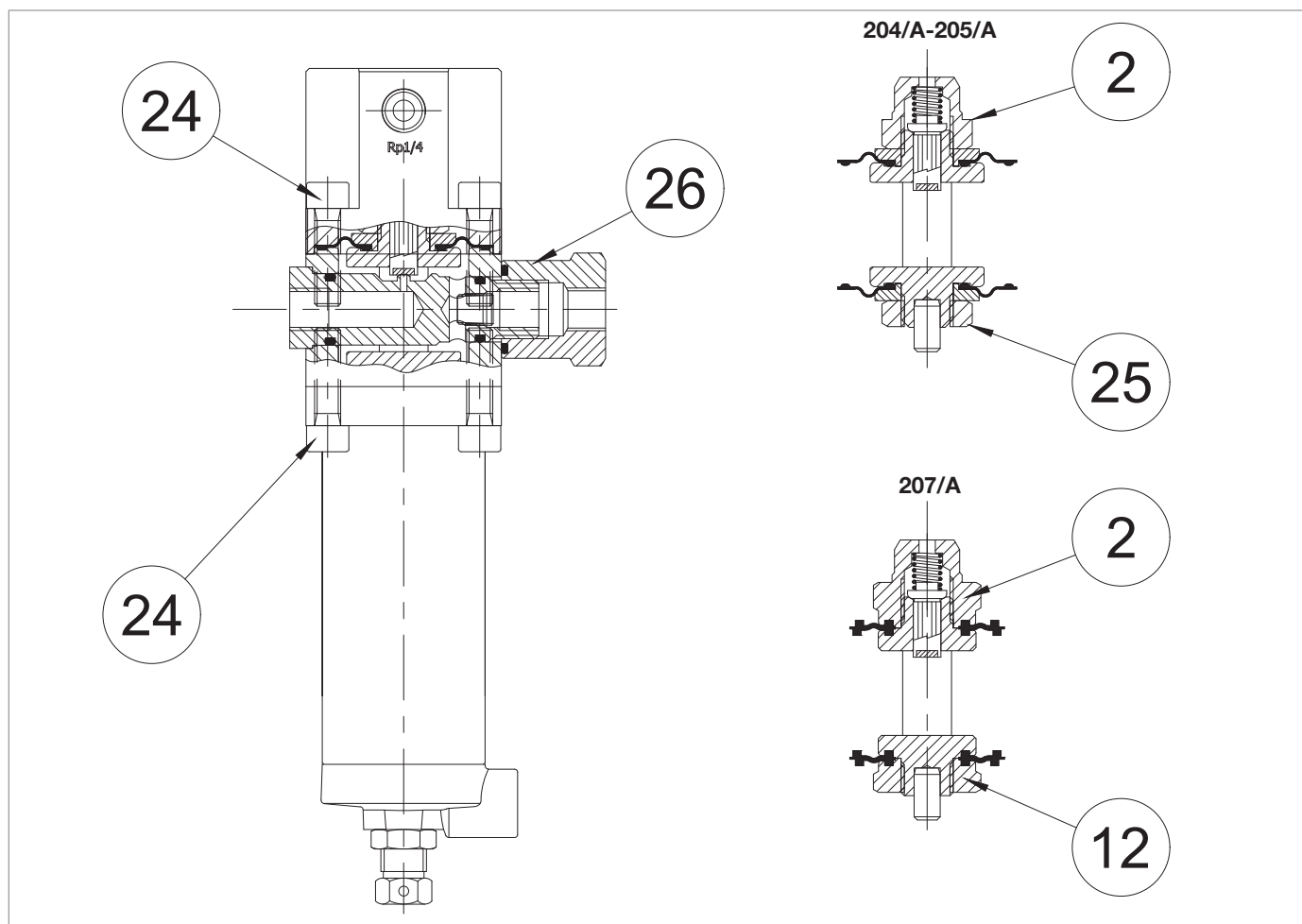
**PILOT 207/A**

Pos.	Description	Torque (nm)	Torque (ft - lb)
2	Nut M16X1	25	18
12	Nut M16X1	25	18
24	Screw M8X30 UNI 5931 AISI	20	14
26	Nut M18X1.5	20	14

Tab. 9.97

### 9.4.1.6 - TIGHTENING TORQUES FOR PRE-REGULATORS R14/A

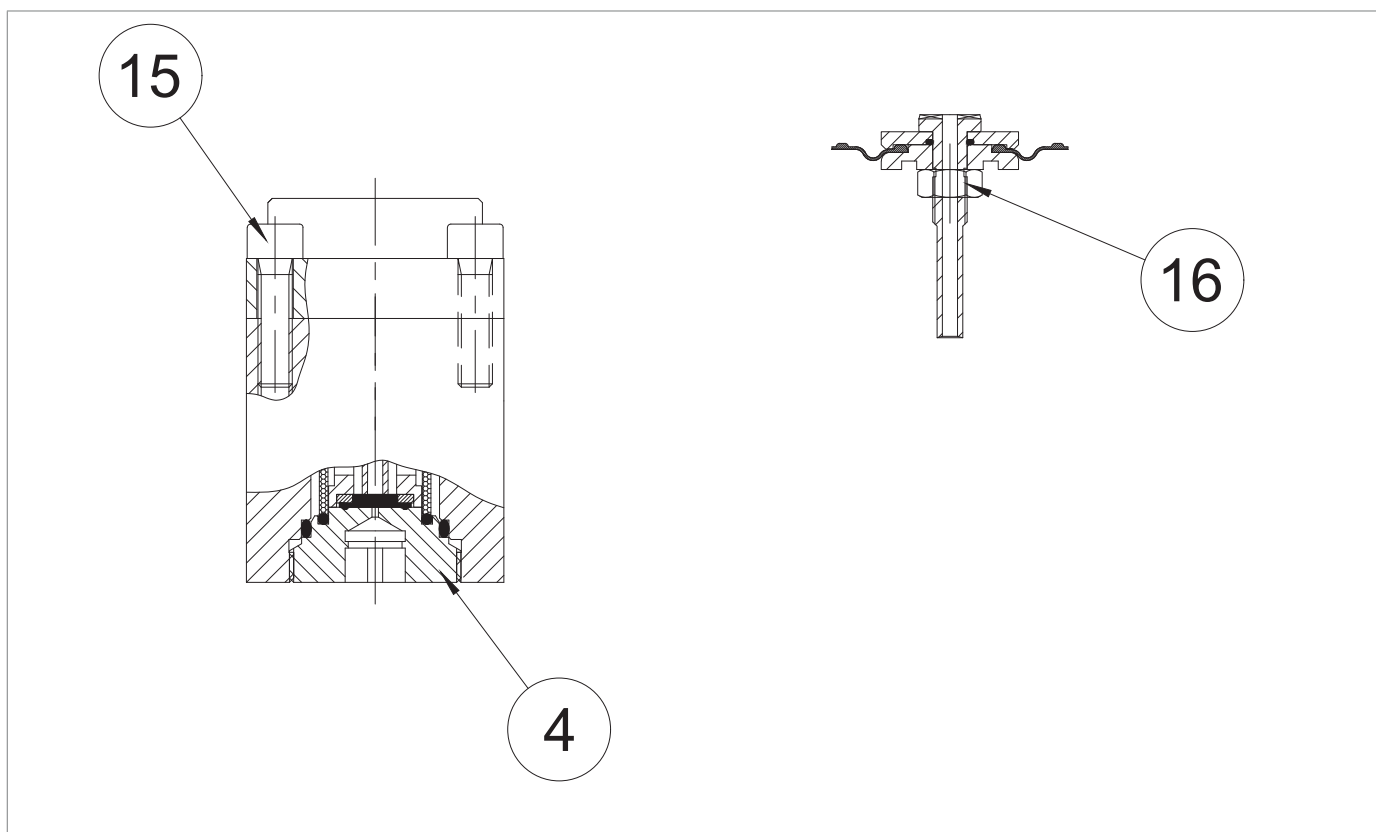

Fig. 9.41. Tightening torques for pre-regulator R14/A

PRE-REGULATOR R14/A			
Pos.	Description	Torque (nm)	Torque (ft - lb)
4	Cap	35	25
15	Nut M8X30 UNI 5931 AISI	20	14
16	Nut M8 UNI 5588	8	5

Tab. 9.98

**9.4.1.7 - TIGHTENING TORQUES FOR SB/82 BUILT-IN SLAM-SHUT VALVE**

Fig. 9.42. Tightening torques for SB/82 1" built-in slam-shut valve

SB/82 1"			
Pos.	Description	Torque (nm)	Torque (ft - lb)
5	Safety valve screw M10	40	29
11	Screw M6X12 UNI 5931	10	7
34	Screw M6X20 UNI 5931	10	7
35	Screw M6X20 UNI 5931	10	7
36	Screw M12X45 UNI 5931	80	59
37	Screw M10X25 UNI 5931	45	33
39	Screw M6X20 UNI 5931	10	7

Tab. 9.99

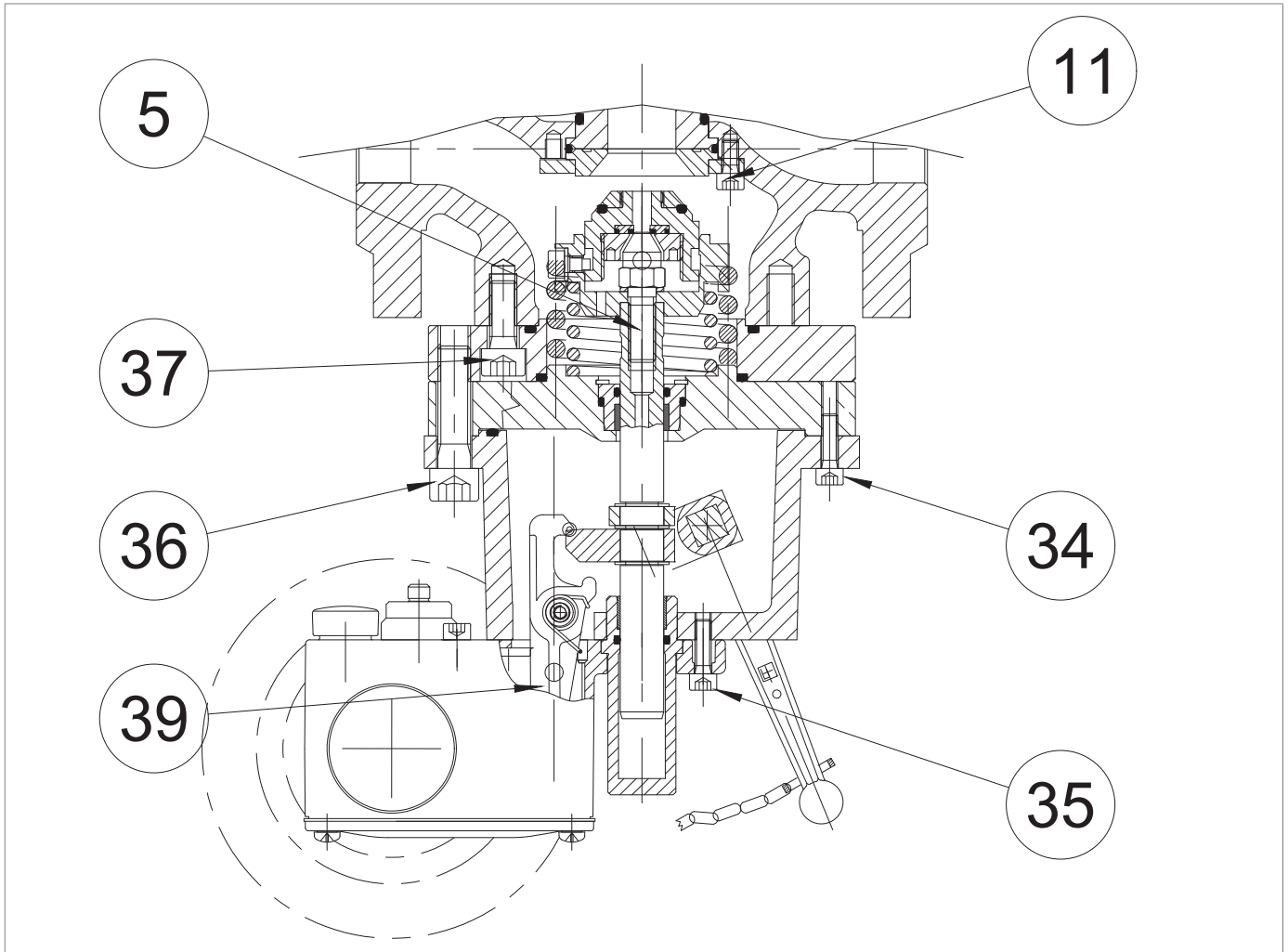
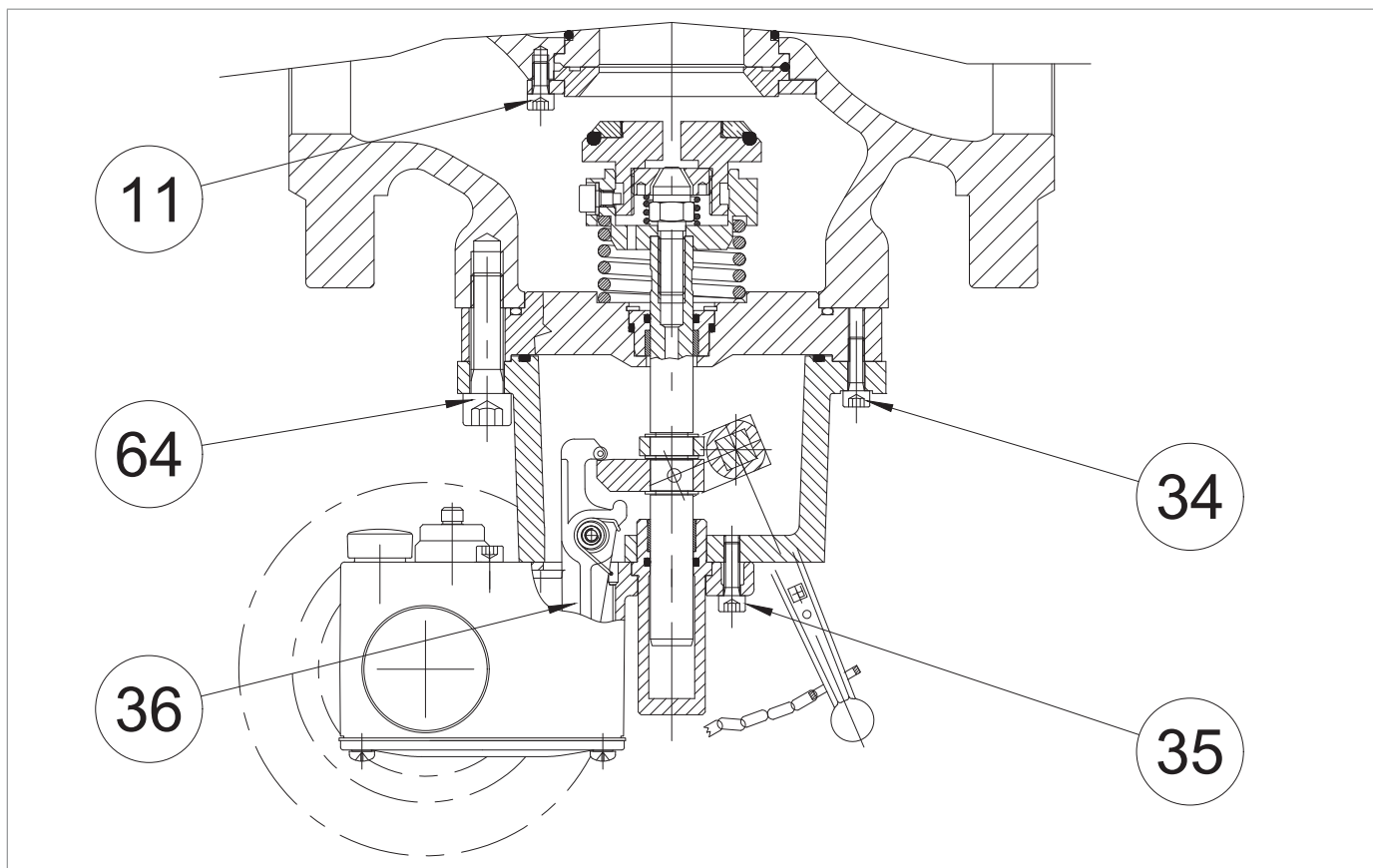

Fig. 9.43. Tightening torques for SB/82 2" built-in slam-shut valve

SB/82 2"			
Pos.	Description	Torque (nm)	Torque (ft - lb)
5	Safety valve screw M10	40	29
11	Screw M6X12 UNI 5931	10	5
34	Screw M6X20 UNI 5931	10	5
35	Screw M6X20 UNI 5931	10	5
36	Screw M6X20 UNI 5931	10	5
64	Screw M12X45 UNI 5931	80	59

Tab. 9.100

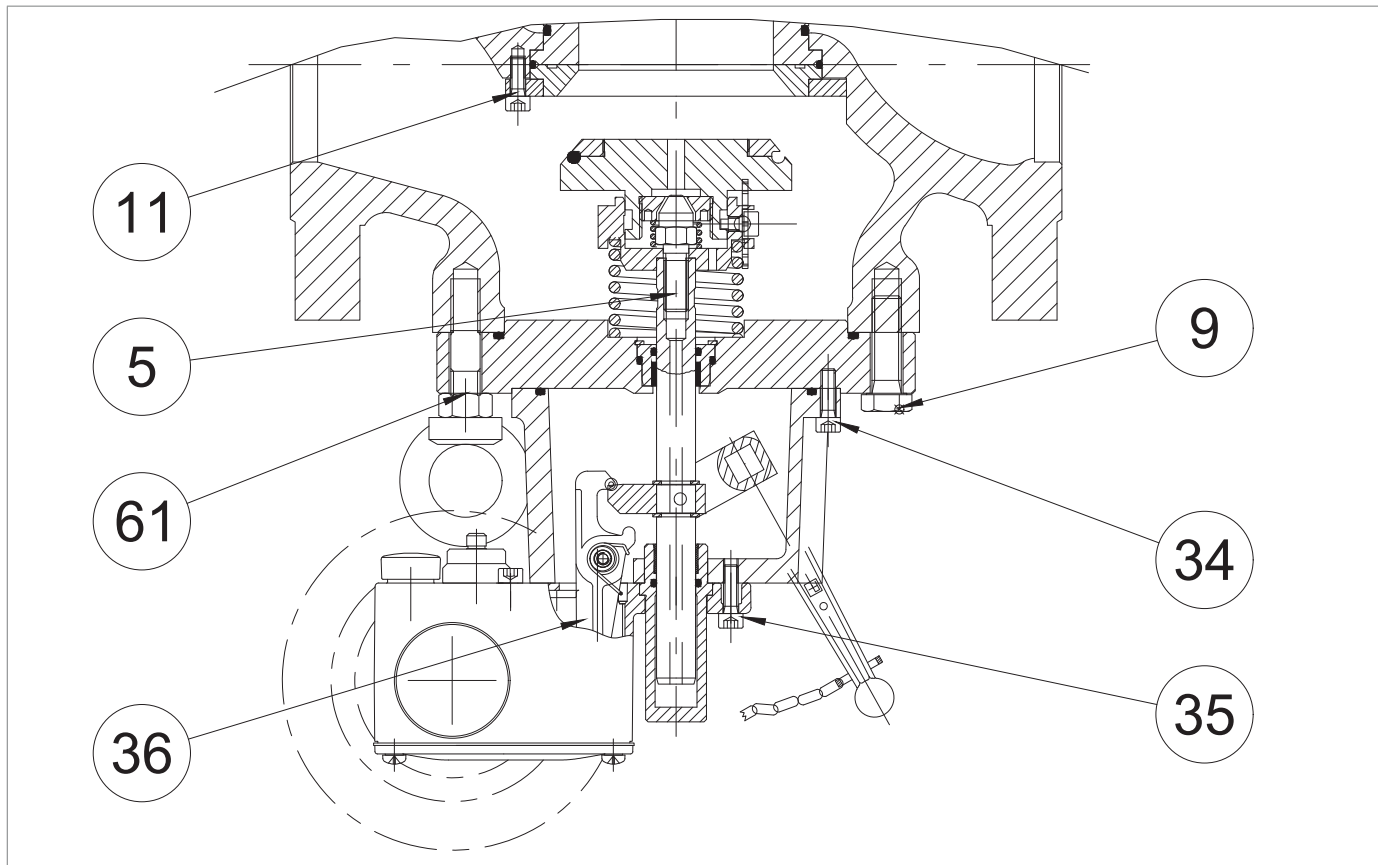

Fig. 9.44. Tightening torques for SB/82 3"- 4" built-in slam-shut valve

SB/82 3"			
Pos.	Description	Torque (nm)	Torque (ft - lb)
5	Safety valve screw M10	40	29
9	Screw M12X40 UNI 5739	80	59
11	Screw M6X12 UNI 5931	10	5
34	Screw M6X20 UNI 5931	10	5
35	Screw M6X20 UNI 5931	10	5
36	Screw M6X20 UNI 5931	10	5
61	Nut M12 UNI 5588	80	59

Tab. 9.101

SB/82 4"			
Pos.	Description	Torque (nm)	Torque (ft - lb)
5	Safety valve screw M10	40	29
9	Screw M16X50 UNI 5737	150	110
11	Screw M6X16 UNI 5931	10	5
33	Screw M6X14 UNI 5934	10	5
34	Screw M6X20 UNI 5931	10	5
35	Screw M6X14 UNI 5933	10	5
36	Screw M6X20 UNI 5931	10	5

Tab. 9.102

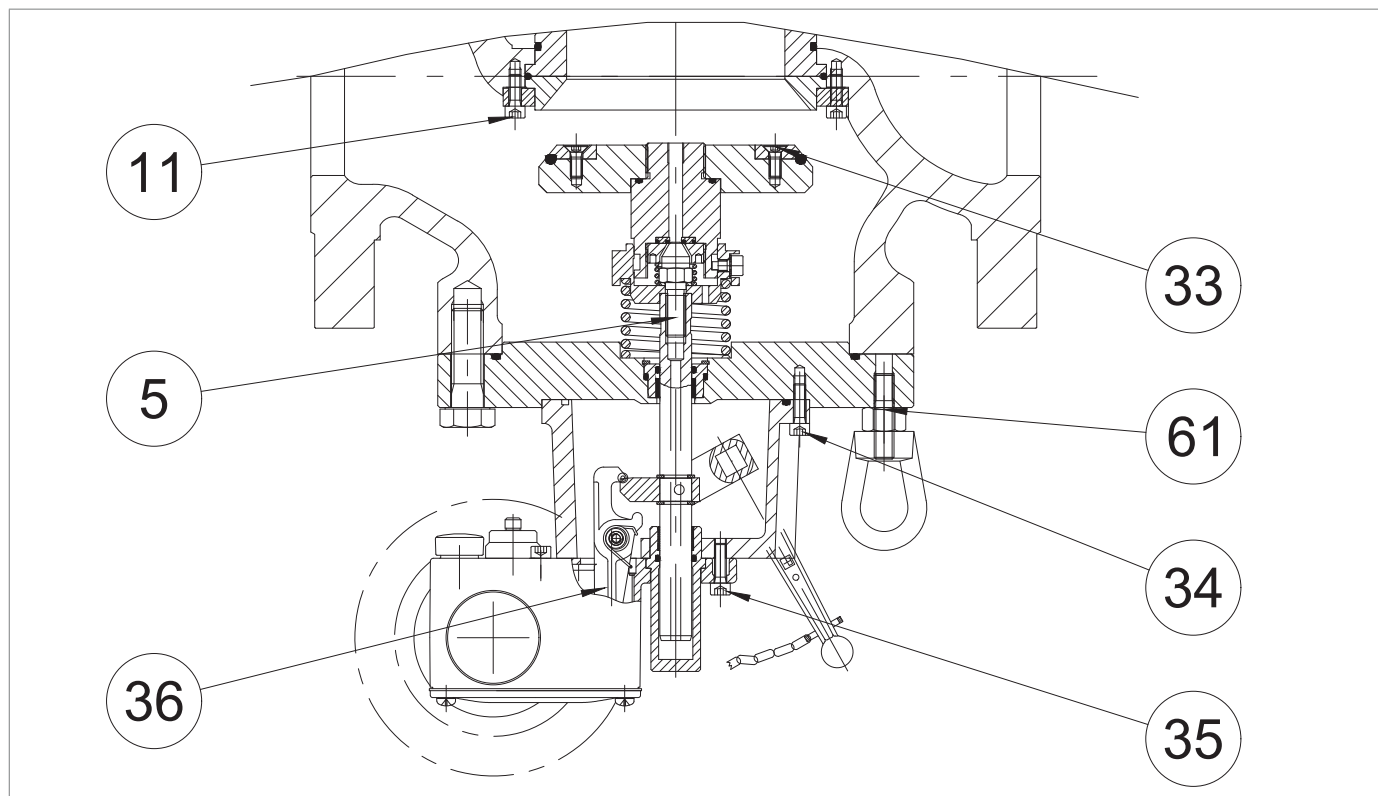

Fig. 9.45. Tightening torques for SB/82 6"- 8" built-in slam-shut valve

### SB/82 6"

Pos.	Description	Torque (nm)	Torque (ft - lb)
5	Safety valve screw	40	29
10	Screw M14X50 UNI 5737	115	84
11	Screw M6X16 UNI 5931	10	5
33	Screw M6X10 UNI 5931	10	5
34	Screw M8X25 UNI 5931	20	14
35	Screw M6X40 UNI 5931	10	5
36	Screw M6X20 UNI 5931	10	5
61	Nut M14 UNI 5588	115	84

Tab. 9.103

### SB/82 8"

Pos.	Description	Torque (nm)	Torque (ft - lb)
5	Safety valve screw M10	40	29
10	Screw M14X50 UNI 5737	115	84
11	Screw M6X16 UNI 5931	10	5
33	Screw M6X10 UNI 5931	10	5
34	Screw M8X25 UNI 5931	20	14
35	Screw M6X40 UNI 5931	10	5
36	Screw M6X20 UNI 5931	10	5
61	Nut M14 UNI 5588	115	84

Tab. 9.104

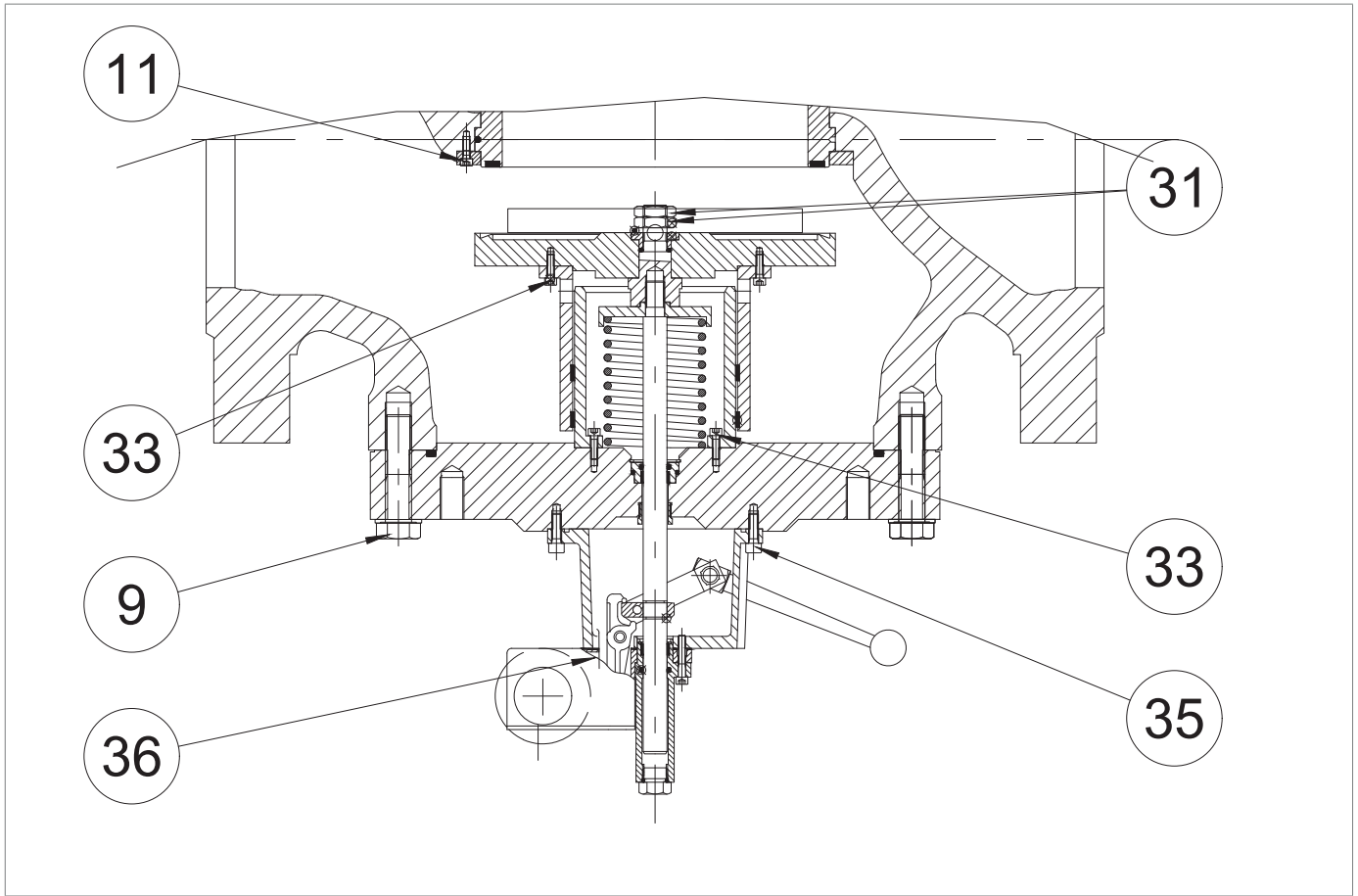

Fig. 9.46. Tightening torques for SB/82 10" built-in slam-shut valve

SB/82 10"			
Pos.	Description	Torque (nm)	Torque (ft - lb)
9	Screw M16X90 UNI 5737	150	110
11	Screw M6X16 UNI 5931	10	5
31	Nut M20 UNI 5589	250	184
33	Screw M6X20 UNI 5931	10	5
35	Screw M8X25 UNI 5931	20	14
36	Screw M6X35 UNI 5931	10	5
137	Screw M6X20 UNI 5931	10	5

Tab. 9.105

PAGE INTENTIONALLY LEFT BLANK

**9.4.1.8 - TIGHTENING TORQUES FOR PRESSURE SWITCHES MODELS 102M/102MH - 105M/105MH**

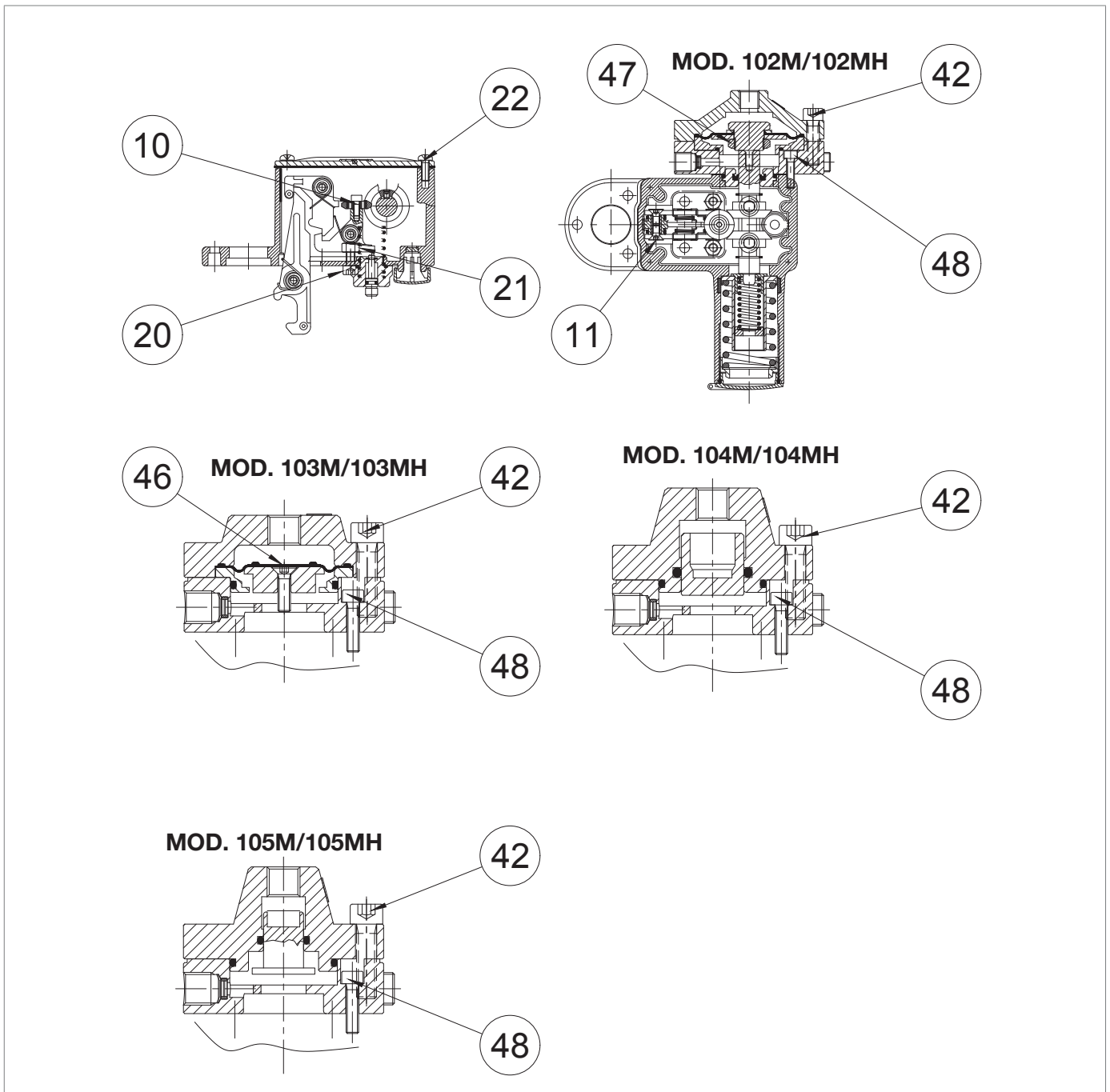

Fig. 9.47. Tightening torques for pressure switches models 102M/102MH - 105M/105MH

**MOD. 102M/102MH**

Pos.	Description	Torque (nm)	Torque (ft - lb)
10	SCREW M4X10 UNI 5931	3	2.21
11	SCREW M5X10 UNI 5933	5	3.68
20	SCREW M6X16 UNI 5931	10	7.37
21	NUT M6 UNI 5588	10	7.37
22	SCREW M5X15 UNI 8112	5	3.68
42	SCREW M6X25 UNI 5931	16	11.80
47	Nut M20X1	8	5.90
48	SCREW M5X16 UNI 5931	5	3.68

*Tab. 9.106*
**MOD. 103M/103MH**

Pos.	Description	Torque (nm)	Torque (ft - lb)
10	SCREW M4X10 UNI 5931	3	2.21
11	SCREW M5X10 UNI 5933	5	3.68
20	SCREW M6X16 UNI 5931	10	7.37
21	NUT M6 UNI 5588	10	7.37
22	SCREW M5X15 UNI 8112	5	3.68
42	SCREW M8X30 UNI 5931	16	11.80
46	SCREW M5X18 UNI 5931	8	5.90
48	SCREW M5X20 UNI 5931	5	3.68

*Tab. 9.107*
**MOD. 104M/104MH - 105M/105MH**

Pos.	Description	Torque (nm)	Torque (ft - lb)
10	SCREW M4X10 UNI 5931	3	2.21
11	SCREW M5X10 UNI 5933	5	3.68
20	SCREW M6X16 UNI 5931	10	7.37
21	NUT M6 UNI 5588	10	7.37
22	SCREW M5X15 UNI 8112	5	3.68
42	SCREW M8X30 UNI 5931	16	11.80
48	SCREW M5X20 UNI 5931	5	3.68

*Tab. 9.108*

### 9.4.1.9 - TIGHTENING TORQUES FOR HB/97 BUILT-IN SLAM-SHUT VALVE WITH LINE-OFF

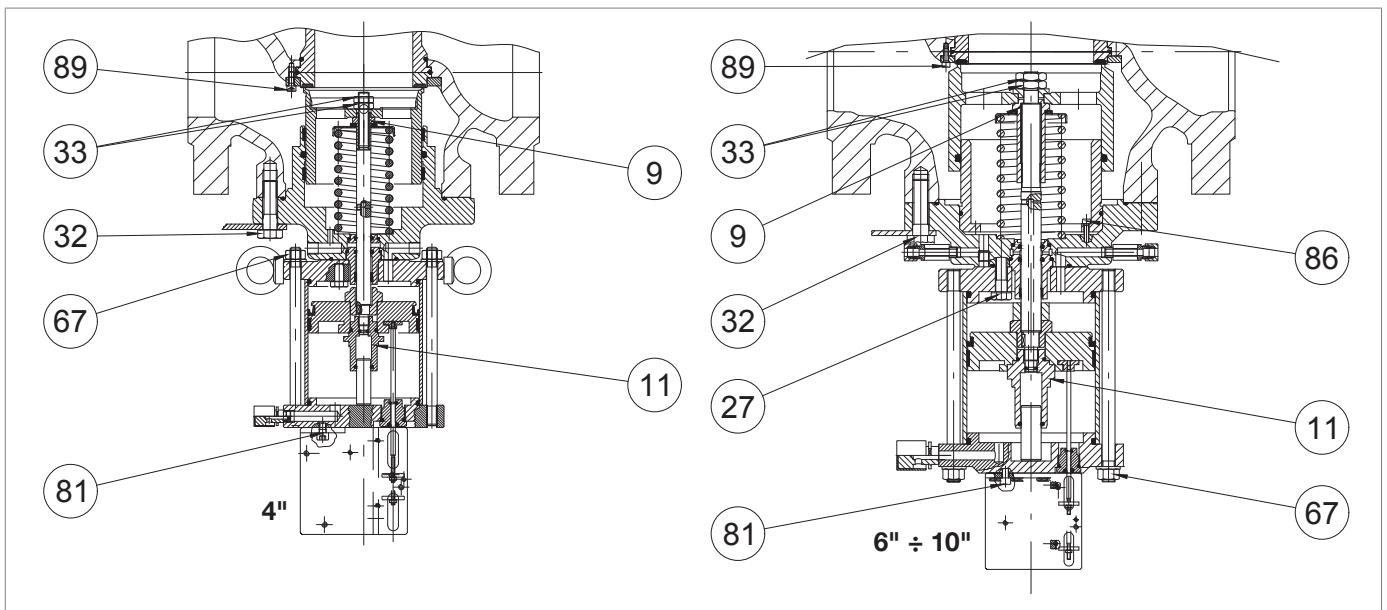

Fig. 9.48. Tightening torques for HB/97 built-in slam-shut valve with LINE OFF

HB/97 4"			
Pos.	Description	Torque (nm)	Torque (ft - lb)
9	Locking nut M12X1.25	35	25
11	M12X1.25 balancing piston guide	35	25
27	Screw M10X40 UNI 5737	45	33
33	Nut M12X1.25 UNI 5589	35	25
67	Nut M12 UNI 5588	80	59
81	Screw M8X16 UNI 5931	20	14
87	Screw M6X16 UNI 5931	10	7

Tab. 9.109

HB/97 6"			
Pos.	Description	Torque (nm)	Torque (ft - lb)
9	Locking nut M24X1.5	110	81
11	M18X1.5 balancing piston guide	110	81
27	Screw M14X50 UNI 5737	115	84
33	Nut M18X1.5 UNI 5589	110	81
67	Nut M16 UNI 5588	200	147
81	Screw M8X20 UNI 5931	20	14
86	Screw M6X25 UNI 5931	10	7
89	Screw M6X16 UNI 5931	10	7

Tab. 9.110

**HB/97 8"**

Pos.	Description	Torque (nm)	Torque (ft - lb)
9	Locking nut M24X1.5	110	81
11	M18X1.5 balancing piston guide	110	81
27	Screw M14X50 UNI 5737	115	84
33	Nut M18X1.5 UNI 5589	110	81
67	Nut M16 UNI 5588	200	147
81	Screw M8X20 UNI 5931	20	14
86	Screw M6X25 UNI 5931	10	7
89	Screw M6X16 UNI 5931	10	7

*Tab. 9.111*
**HB/97 10"**

Pos.	Description	Torque (nm)	Torque (ft - lb)
9	Locking nut M30X1.5	150	110
11	M22X1.5 balancing piston guide	150	110
27	Screw M20X70 UNI 5931	250	184
33	Nut M20X1.5 UNI 5589	150	110
67	Nut M16 UNI 5588	200	147
81	Screw M8X20 UNI 5931	20	14
86	Screw M6X25 UNI 5931	10	7
89	Screw M6X16 UNI 5931	10	7

*Tab. 9.112*

9.4.1.10 - TIGHTENING TORQUES FOR HP2/2 BYPASS DEVICE

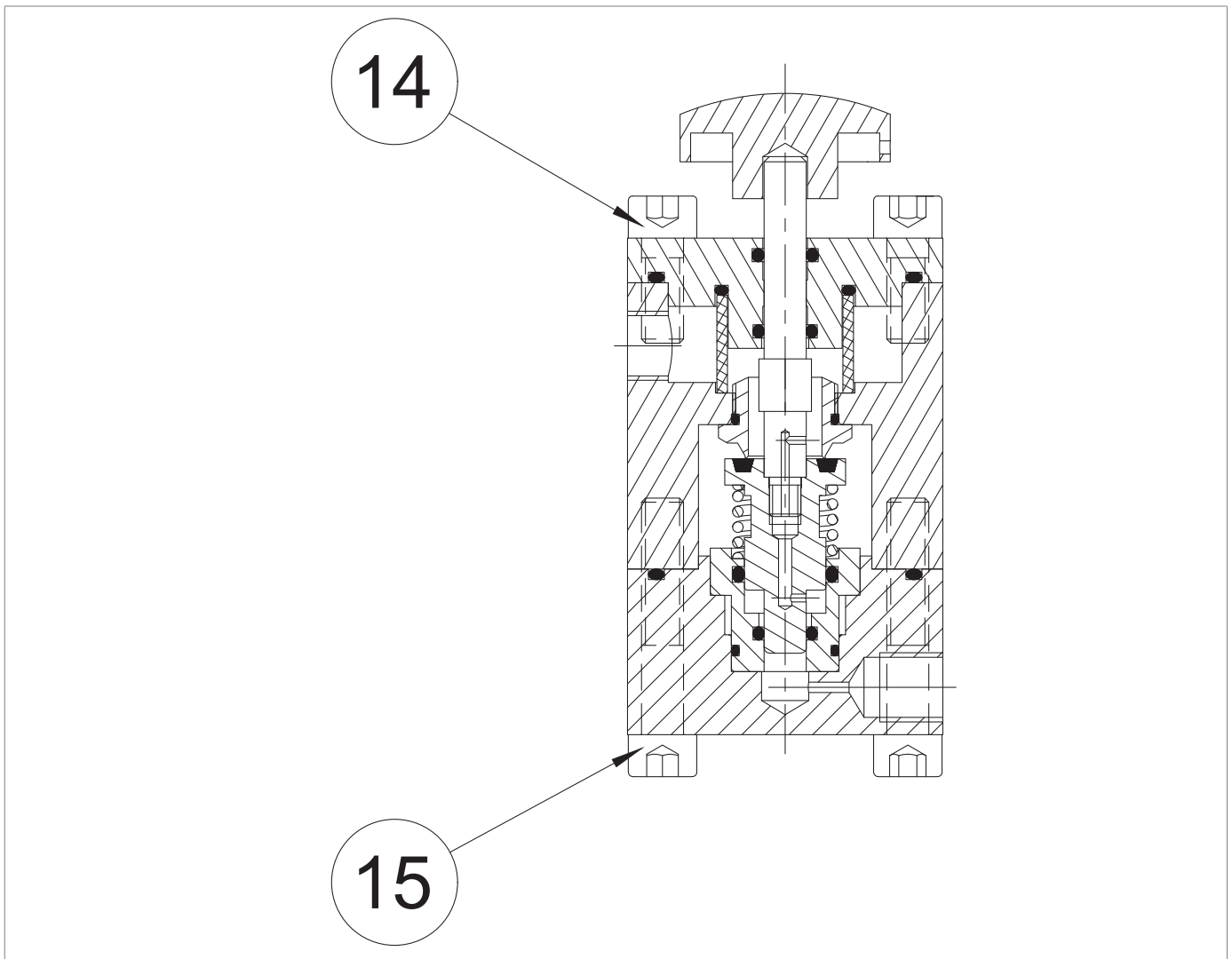

Fig. 9.49. Tightening torques for HP2/2 bypass device

HP/22			
Pos.	Description	Torque (nm)	Torque (ft - lb)
14	Screw M8X20 UNI 5931	16	11
15	Screw M8X45 UNI 5931	16	11

Tab. 9.113

**9.4.1.11 - TIGHTENING TORQUES FOR R44/SS REGULATOR**

Fig. 9.50. Tightening torques for R44/SS regulator

R44/SS			
Pos.	Description	Torque (nm)	Torque (ft - lb)
2	Nut M16X1	25	18
24	Screw M8X110 UNI 5931	16	11
24.1	Screw M8X70 UNI 5931	16	11
25	Nut M16X1.5	25	18
26	Nut M18X1.5	20	14

Tab. 9.114

PAGE INTENTIONALLY LEFT BLANK

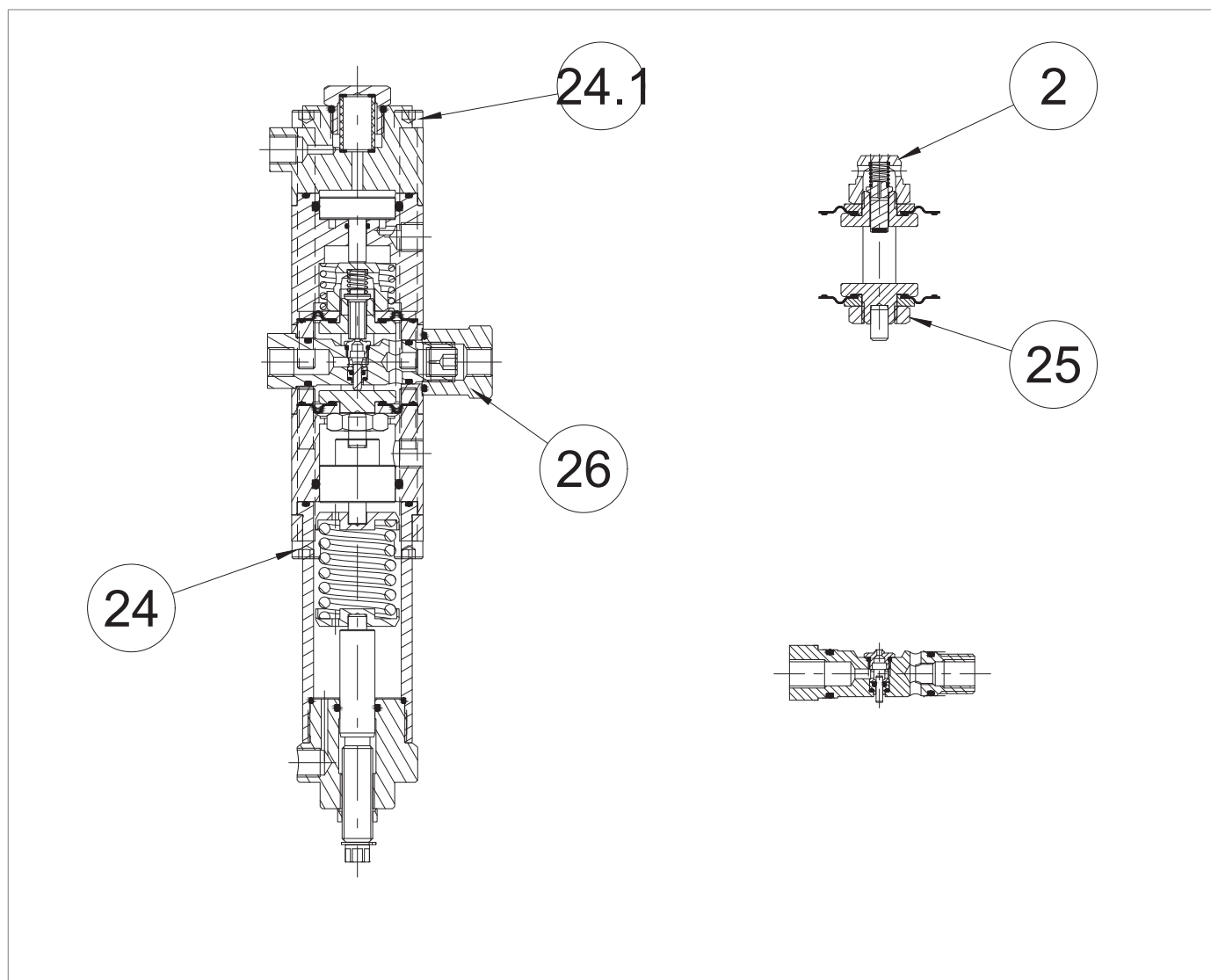
## 9.4.2 - REPLACING ELEMENTS SUBJECT TO WEAR AND ABRASION

### 9.4.2.1 - INITIAL OPERATIONS

#### WARNING!

Before any intervention, it is necessary:

- to ensure that the line on which the equipment is installed is shut off upstream and downstream;
  - to operate the slam shut valve in manual mode by pressing the release button (Pos. 10 - Figure 4.11.).
- Next, check that the pressure indicated by the pressure gauge installed on the LINE OFF 2.0 device (Pos. 7.3 - Figure 8.31.) is 0 bar, ensuring complete depressurisation of the line.

#### ATTENTION!

During assembly, make sure to tighten the screws as per the tables (tightening torques), according to the size for which maintenance is being carried out.

Proceed as follows:

Step	Action
1	Unscrew the conical seal fittings to disconnect all power outlets and sensing lines for the pilot and regulator.
2	Loosen the nut securing the pilot support bracket to the regulator.
3	Remove the following from the regulator: <ul style="list-style-type: none"> <li>• the installed series 300 pilot;</li> <li>• the AR100 throttle valve.</li> </ul> <div style="border: 1px solid blue; padding: 5px; margin-top: 10px;"> <p> <b>NOTICE!</b></p> <p>To replace the components of the piloting unit, refer to paragraphs “9.4.3 - Regulator APERFLUX 851 1” ÷ 3” and “9.4.6 - PM/819 built-in monitor maintenance”.</p> </div>

Tab. 9.115

### 9.4.2.2 - CROSS DIAGRAM FOR TIGHTENING SCREWS

When indicated by the maintenance procedure, refer to the following diagram to tighten the screws:

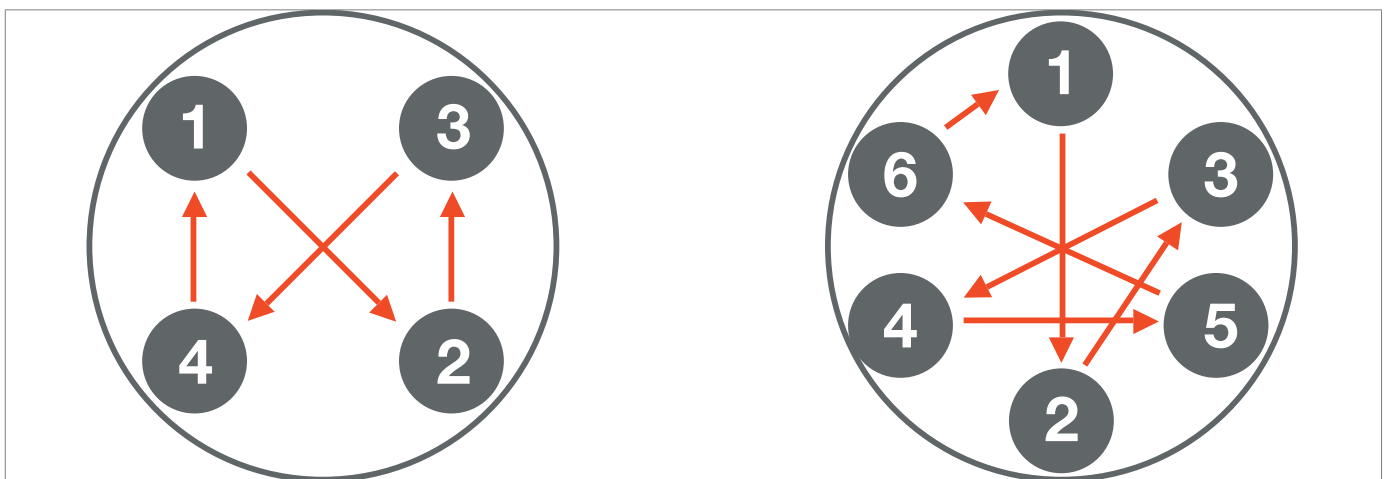

Fig. 9.51. Cross diagram

**9.4.3 - REGULATOR APERFLUX 851 1" ÷ 3"**

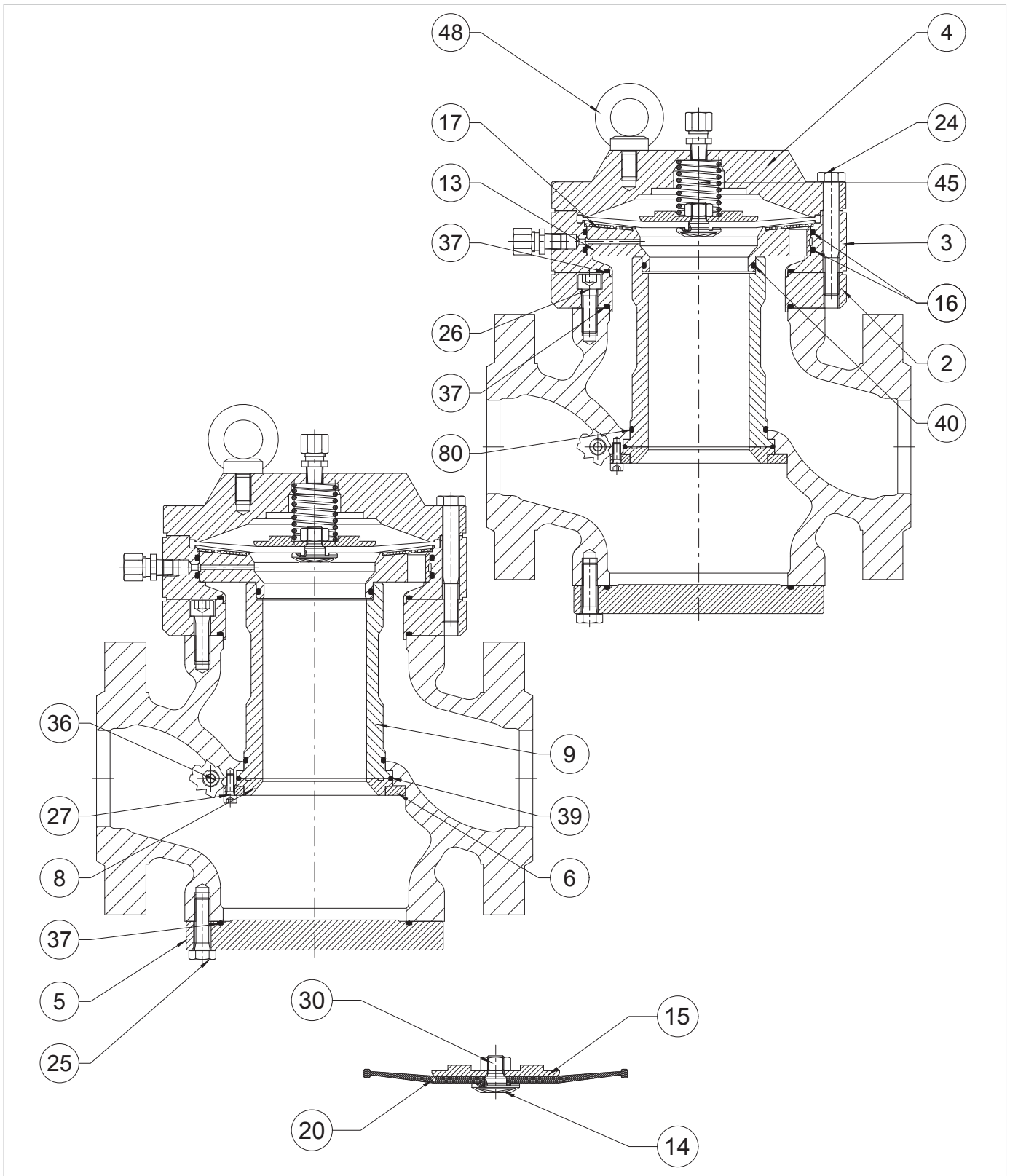





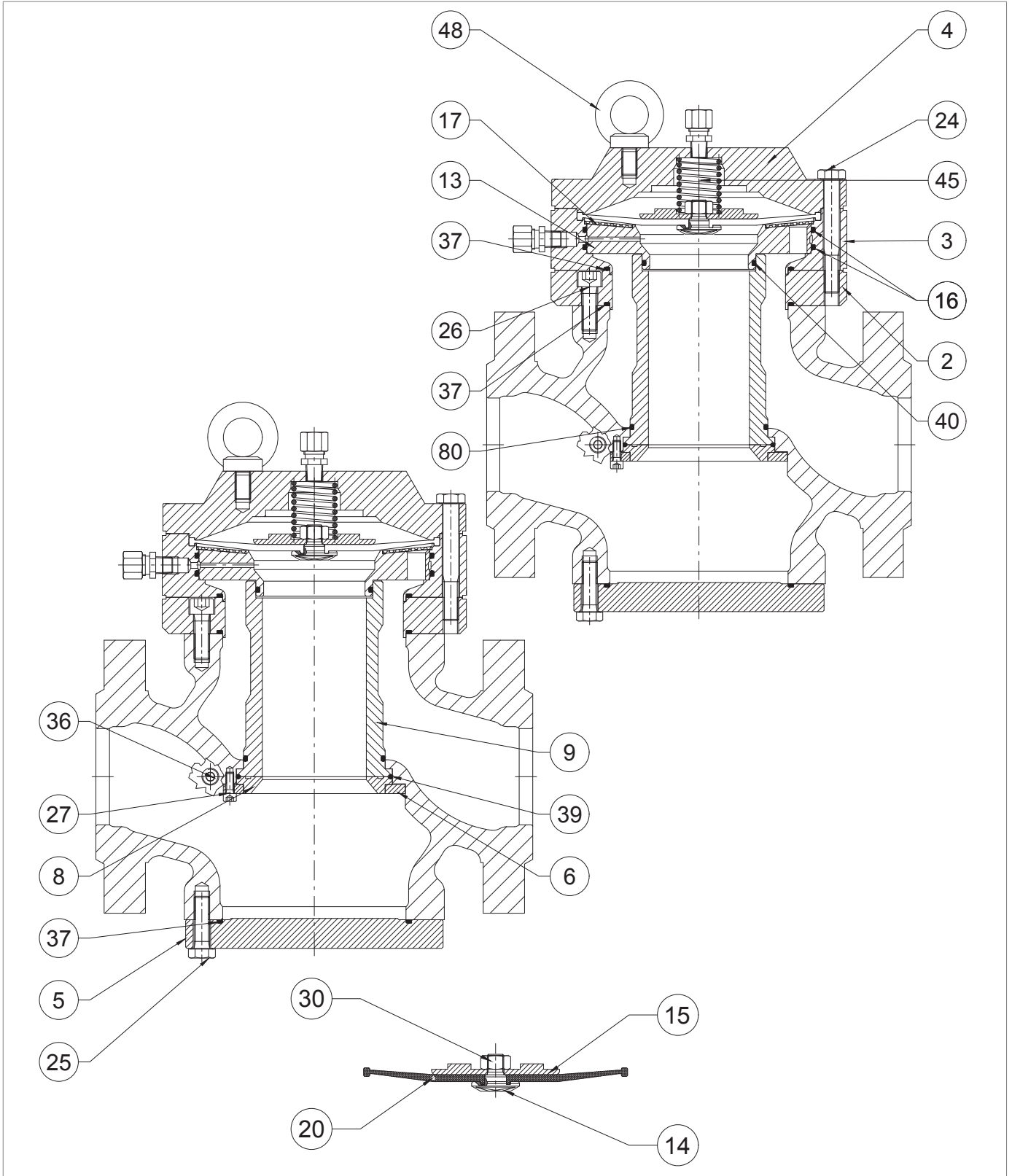









Fig. 9.52. Regulator APERFLUX 851 1" ÷ 3"

Step	Action
1	Loosen the fixing screws (24).
2	Remove the upper lid (4).
3	Remove the spring (45).
4	Take out the diaphragm unit (14, 15, 20, 30).
5	Loosen and remove nut (30)
6	Remove the diaphragm protection disc (15).
7	Remove and replace the diaphragm (20) from the screw (14), taking care to lubricate the lanyard with synthetic grease.
8	Assemble the diaphragm unit, placing the diaphragm (20) in the screw (14).  <b>NOTICE!</b> <b>Carefully place the diaphragm O-ring (20) into the screw slot (14).</b>
9	Fit the diaphragm protection disc (15).
10	Fix the nut (30) according to the following tightening torques: <ul style="list-style-type: none"> <li>• 1" : "Tab. 9.72";</li> <li>• 2" : "Tab. 9.73";</li> <li>• 3" : "Tab. 9.74".</li> </ul>
11	Remove the membrane protection grille (17).
12	Remove the intermediate flange (3) together with the valve seat (13).
13	Turn the intermediate flange (3) upside down.
14	Press and pull out the valve seat (13).  <b>NOTICE!</b> <b>Place it on a shockproof surface to facilitate the operation and to protect it in the event of a fall.</b>
15	<b>a - ONLY VALID FOR 3"</b> Remove the O-ring (40) from the valve seat (13) and replace it, lubricating it with synthetic grease.  <b>NOTICE!</b> <b>Before inserting the replacement O-ring, clean the retaining slots with a cleaning solution.</b> <b>b -</b> Remove the O-rings (16) from the intermediate flange (3) and replace them, taking care to lubricate them with synthetic grease.  <b>NOTICE!</b> <b>Before inserting the replacement O-ring, clean the retaining slots with a cleaning solution</b>
16	Remove the O-ring (37) from the intermediate flange (3) and replace it, lubricating it with synthetic grease.  <b>NOTICE!</b> <b>Before inserting the replacement O-ring, clean the retaining slots with a cleaning solution</b>
17	<b>a - ONLY VALID FOR 3"</b> Unscrew and remove the screws (26) from the flange (2). <b>b -</b> Remove screws (25) and blind flange (5).  <b>NOTICE!</b> <b>Support the flange to prevent it from falling.</b>



Regulator APERFLUX 851 1" ÷ 3"

Step	Action
18	<b>a - ONLY VALID FOR 3"</b> Remove the O-ring (37) from the intermediate flange (2) and replace it, lubricating it with synthetic grease.
	<div style="border: 1px solid black; padding: 2px;">  <b>NOTICE!</b> </div> <p><b>Before inserting the replacement O-ring, clean the retaining slots with a cleaning solution.</b></p>
19	<b>b -</b> Remove the O-ring (37) from the blind flange (5) and replace it, taking care to lubricate it with synthetic grease.
	<div style="border: 1px solid black; padding: 2px;">  <b>NOTICE!</b> </div> <p><b>Before inserting the replacement O-ring, clean the retaining slots with a cleaning solution.</b></p>
19	Undo and remove the screws (27).
20	Remove the shaft collar (6), the conical seat (8) and the O-ring (39).
21	Remove the sleeve (9) from the top downwards, exerting slight pressure.
	<div style="border: 1px solid black; padding: 2px;">  <b>NOTICE!</b> </div> <p><b>Take care to support the lower part of the sleeve (9).</b></p>
22	Remove the O-ring (80) from the sleeve (9) and replace it, taking care to lubricate it with synthetic grease.
	<div style="border: 1px solid black; padding: 2px;">  <b>NOTICE!</b> </div> <p><b>Before inserting the replacement O-ring, clean the retaining slots with a cleaning solution.</b></p>
23	Clean and wash the upper and lower contact surfaces of the body, the flanges, the contact surfaces between the sleeve (9), conical seat (8) and the body.
24	Reposition the sleeve (9) of the body from top to bottom, applying light pressure.
	<div style="border: 1px solid black; padding: 2px;">  <b>NOTICE!</b> </div> <p><b>Take care not to damage the O-ring (80).</b></p>
25	Replace the O-ring (39) and lubricate it with synthetic grease.
26	Put the conical seat (8) back in place together with the O-ring (39), the shaft collar (6).
27	Insert and fix the screws (27) according to the following tightening torques: <ul style="list-style-type: none"> <li>• 1" : "Tab. 9.72";</li> <li>• 2" : "Tab. 9.73";</li> <li>• 3" : "Tab. 9.74".</li> </ul>
	<div style="border: 1px solid black; padding: 2px;">  <b>NOTICE!</b> </div> <p><b>Tighten the screws as shown in the diagram at "9.4.2.2 - Cross diagram for tightening screws".</b></p>
28	Fit the blind flange (4).
29	Insert and fix the screws (25) according to the following tightening torques: <ul style="list-style-type: none"> <li>• 1" : "Tab. 9.72";</li> <li>• 2" : "Tab. 9.73";</li> <li>• 3" : "Tab. 9.74".</li> </ul>
	<div style="border: 1px solid black; padding: 2px;">  <b>NOTICE!</b> </div> <p><b>Tighten the screws as shown in the diagram at "9.4.2.2 - Cross diagram for tightening screws".</b></p>
30	Insert the valve seat (13) into the intermediate flange (3) from top to bottom.

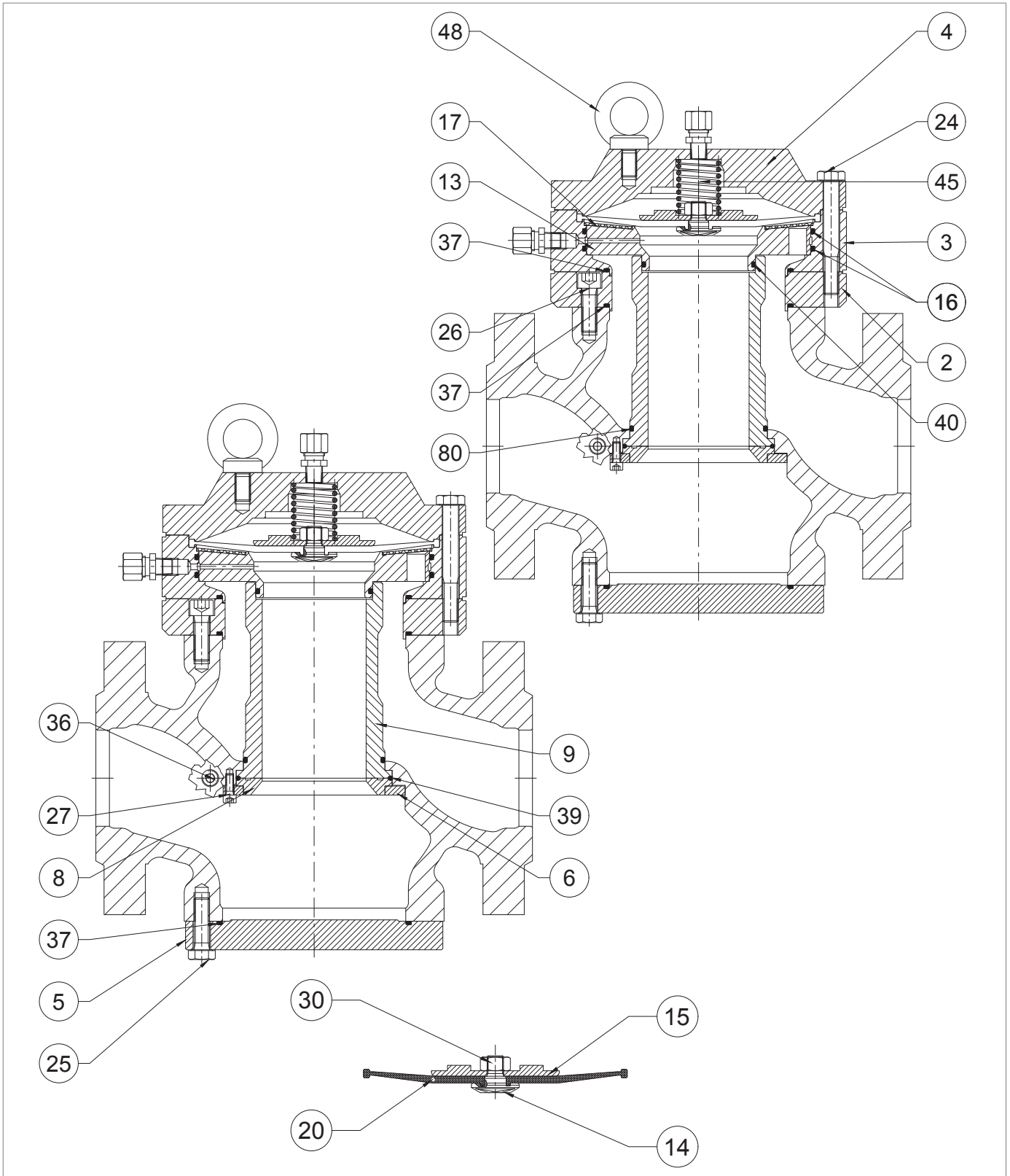

Regulator APERFLUX 851 1" ÷ 3"

Step	Action
31	<p><b>a - ONLY VALID FOR 3"</b></p> <p>Position the flange (2) and the screws (26), fixing them according to the tightening torques:</p> <ul style="list-style-type: none"> <li>• 1" : "Tab. 9.72";</li> <li>• 2" : "Tab. 9.73";</li> <li>• 3" : "Tab. 9.74".</li> </ul>
	<p><b>NOTICE!</b></p> <p><b>Tighten the screws as shown in the diagram at "9.4.2.2 - Cross diagram for tightening screws".</b></p>
32	<p><b>b -</b> Put the intermediate flange (3) back in.</p>
	<p><b>NOTICE!</b></p> <p><b>Make sure the AR100 throttle valve feed hole faces the flow inlet side.</b></p>
32	Put the membrane protection grille (17) back in.
33	Put the diaphragm unit (14, 15, 20, 30) back in.
	<p><b>NOTICE!</b></p> <p><b>Take care to lubricate the retaining slots with synthetic grease.</b></p>
34	Put the spring (45) back in.
35	Remove the upper lid (4).
36	<p>Insert and fix the screws (24) according to the following tightening torques:</p> <ul style="list-style-type: none"> <li>• 1" : "Tab. 9.72";</li> <li>• 2" : "Tab. 9.73";</li> <li>• 3" : "Tab. 9.74".</li> </ul>
	<p><b>NOTICE!</b></p> <p><b>Tighten the screws as shown in the diagram at "9.4.2.2 - Cross diagram for tightening screws".</b></p>

Tab. 9.116

**! WARNING!**

**Ensure that all parts have been fitted correctly.**

9.4.3.1 - REGULATOR APERFLUX 851 4" ÷ 8"

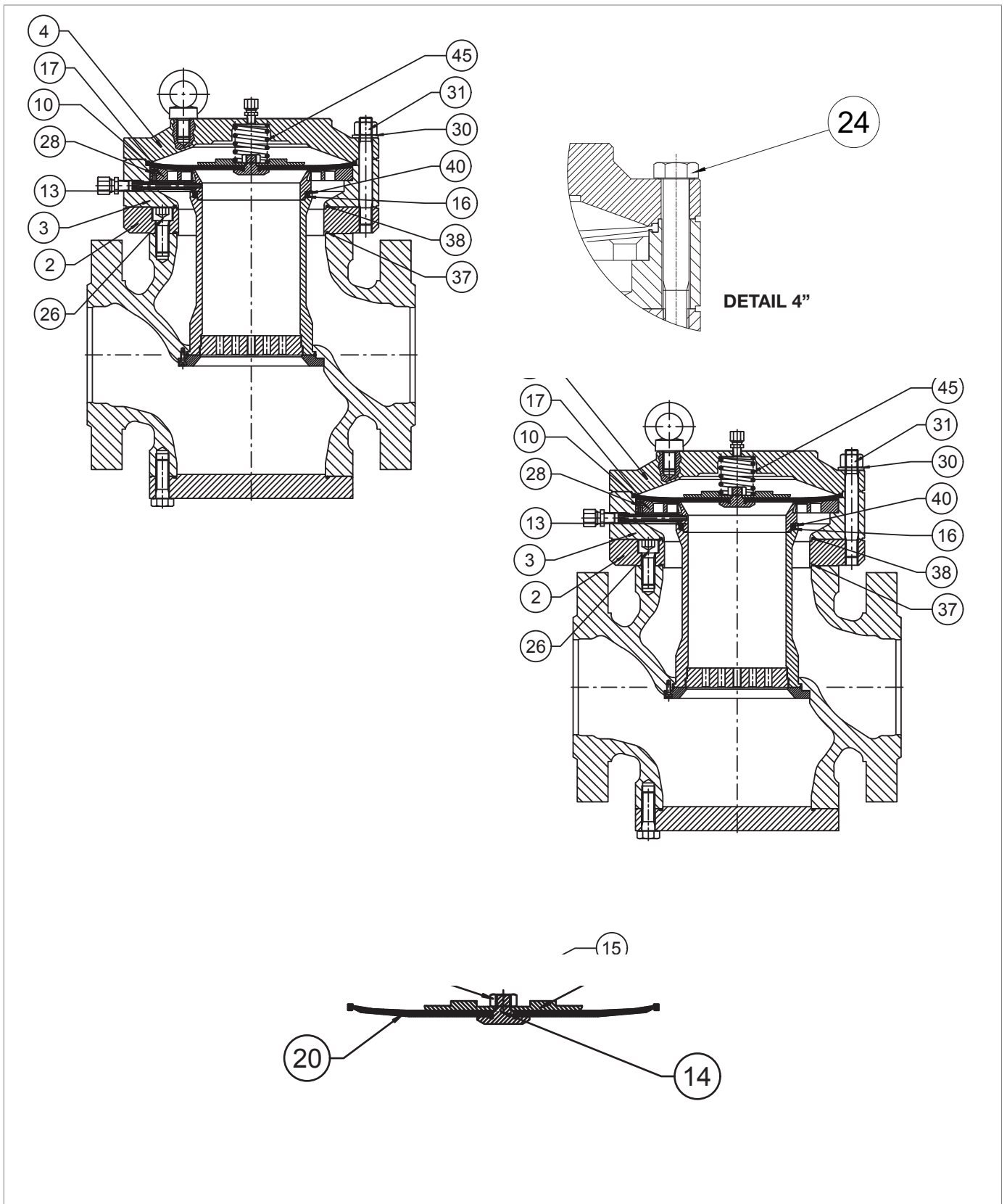
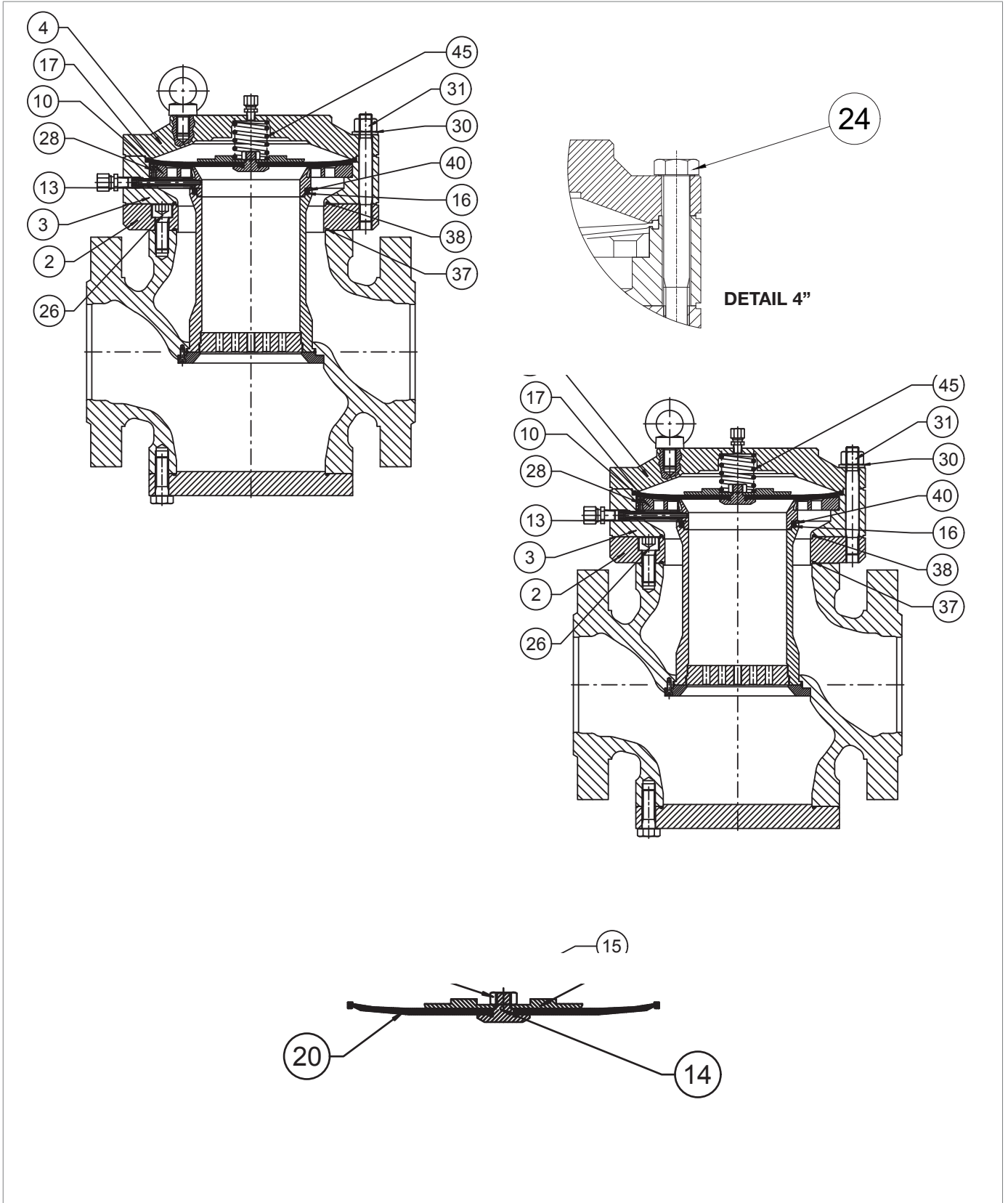

Fig. 9.53. Regulator APERFLUX 851 4" ÷ 8"

Step	Action
1	<b>a - ONLY VALID FOR 4"</b> Loosen the eyebolt and fixing screws (24).
	<b>b - ONLY VALID FOR 6" ÷ 8"</b> Loosen fixing nuts (31).
2	Remove the upper lid (4).
3	Remove the spring (45).
4	Take out the diaphragm unit (14, 15, 20, 30).
5	Loosen and remove nut (30).
6	Remove the diaphragm protection disc (15).
7	Remove the diaphragm (20) and remove it from the screw (14).
	<b>! NOTICE!</b> <b>Lubricate the lanyard with synthetic grease.</b>
8	Fit the diaphragm protection disc (15).
9	Fix the nut (30) according to the following tightening torques:
	<ul style="list-style-type: none"> <li>• 4" : "Tab. 9.75";</li> <li>• 6" : "Tab. 9.76";</li> <li>• 8" : "Tab. 9.77".</li> </ul>
10	Unscrew and remove the feed connection (35).
11	Unscrew and remove the fitting (11).
12	Remove the O-rings (41, 42) from the fitting (11) and replace them, lubricating them with synthetic grease.
	<b>! NOTICE!</b> <b>Before inserting the replacement O-rings, clean the retaining slots with a cleaning solution.</b>
13	Remove the membrane protection grille (17).
14	Undo and remove the screws (28).
15	Remove the grid (10).
16	Remove the valve seat (13).
	<b>! NOTICE!</b> <b>Place it on a shockproof surface to facilitate the operation and to protect it in the event of a fall.</b>
17	Remove the O-ring (40) from the valve seat (13) and replace it, lubricating it with synthetic grease.
	<b>! NOTICE!</b> <b>Before inserting the replacement O-ring, clean the retaining slots with a cleaning solution.</b>
18	Remove spacer ring (16).
19	Remove the intermediate flange (3).
20	Remove the O-ring (38) from the intermediate flange (3) and replace it, lubricating it with synthetic grease.
	<b>! NOTICE!</b> <b>Before inserting the replacement O-ring, clean the retaining slots with a cleaning solution.</b>
21	Undo and remove the screws (26).
22	Remove the flange (2).







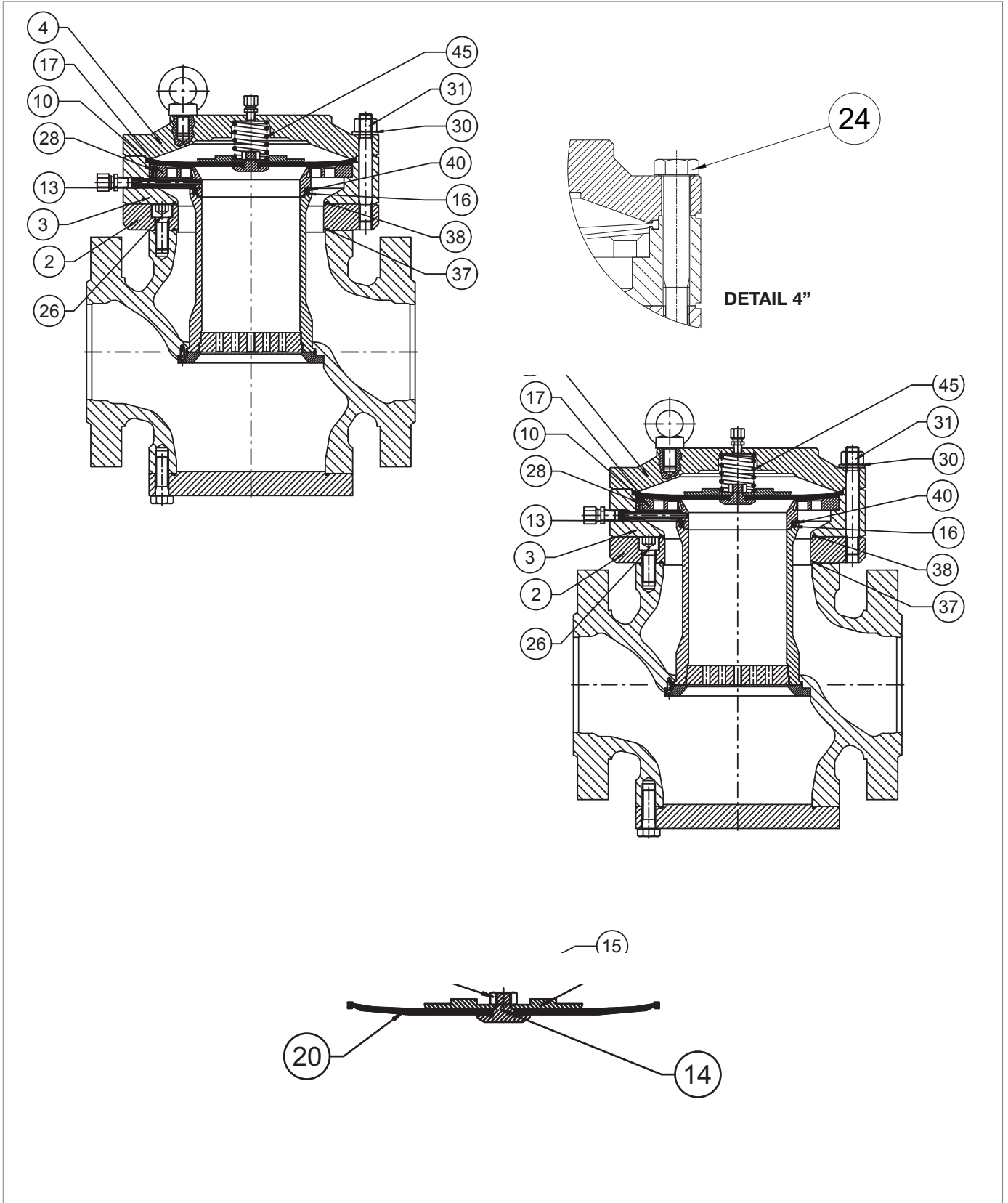

Regulator APERFLUX 851 4" ÷ 8"

Step	Action
23	Remove the O-ring (37) from the flange (2) and replace it, lubricating it with synthetic grease. <b>NOTICE!</b> <b>Before inserting the replacement O-ring, clean the retaining slots with a cleaning solution.</b>
24	Undo the screws (25). <b>NOTICE!</b> <b>Support the flange to prevent it from falling.</b>
25	Remove the blind flange (5).
26	Remove the O-ring (37) from the blind flange (5) and replace it, lubricating it with synthetic grease. <b>NOTICE!</b> <b>Before inserting the replacement O-ring, clean the retaining slots with a cleaning solution.</b>
27	<b>WARNING!</b> <b>Support the sleeve during the next steps to prevent it from falling.</b>
28	Undo and remove the screws (27).
29	Remove the conical seat (8) and the O-ring (39). <b>NOTICE!</b> <b>A reinforced gasket may be fitted instead of the conical seat.</b>
30	Remove the sleeve (9) from the top downwards.
31	Clean the upper and lower bearing surfaces of the body (1) and the flanges (2, 5), the contact surfaces between the sleeve (9), conical seat (8) and the body.
32	Insert the sleeve (9) of the body from the bottom upwards.
33	Replace the O-ring (39) and lubricate it with synthetic grease.
34	Fit the conical seat (8).
35	Insert and fix the screws (27) according to the following tightening torques: <ul style="list-style-type: none"> <li>4" : "Tab. 9.75";</li> <li>6" : "Tab. 9.76";</li> <li>8" : "Tab. 9.77".</li> </ul> <b>NOTICE!</b> <b>Tighten the screws as shown in the diagram at "9.4.2.2 - Cross diagram for tightening screws".</b>
36	Fit the blind flange (5). <b>NOTICE!</b> <b>Support the flange to prevent it from falling.</b>
37	Insert and fix the screws (25) according to the following tightening torques: <ul style="list-style-type: none"> <li>4" : "Tab. 9.75";</li> <li>6" : "Tab. 9.76";</li> <li>8" : "Tab. 9.77".</li> </ul> <b>NOTICE!</b> <b>Tighten the screws as shown in the diagram at "9.4.2.2 - Cross diagram for tightening screws".</b>



Regulator APERFLUX 851 4" ÷ 8"

Step	Action
38	Fit the flange (2).
39	Insert and fix the screws (26) according to the following tightening torques: <ul style="list-style-type: none"> <li>• 4" : "Tab. 9.75";</li> <li>• 6" : "Tab. 9.76";</li> <li>• 8" : "Tab. 9.77".</li> </ul> <div style="border: 1px solid blue; padding: 5px;">  <b>NOTICE!</b>  <b>Tighten the screws as shown in the diagram at "9.4.2.2 - Cross diagram for tightening screws".</b> </div>
40	Fit the intermediate flange (3). <div style="border: 1px solid blue; padding: 5px;">  <b>NOTICE!</b>  <b>Make sure that the supply hole of the AR100 throttle valve faces upstream.</b> </div>
41	Place the ring (16) in the sleeve with the grooves facing downwards.
42	Insert the valve seat (13) with the supply hole facing upstream. <div style="border: 1px solid blue; padding: 5px;">  <b>NOTICE!</b>  <b>Take care not to damage the O-ring (40).</b> </div>
43	Insert and screw the fitting (11) into the hole, taking care not to damage the O-rings (41, 42), according to the tightening torques: <ul style="list-style-type: none"> <li>• 4" : "Tab. 9.75";</li> <li>• 6" : "Tab. 9.76";</li> <li>• 8" : "Tab. 9.77".</li> </ul> <div style="border: 1px solid blue; padding: 5px;">  <b>NOTICE!</b> <ul style="list-style-type: none"> <li>• <b>Push the O-ring (41) of the fitting (11) into the valve seat hole (12).</b></li> <li>• <b>Take care not to move the seat from its centring.</b></li> </ul> </div>
44	Mount the feed connection (35).
45	Fit the grid (10).
46	Insert and fix the screws (28) according to the following tightening torques: <ul style="list-style-type: none"> <li>• 4" : "Tab. 9.75";</li> <li>• 6" : "Tab. 9.76";</li> <li>• 8" : "Tab. 9.77".</li> </ul> <div style="border: 1px solid blue; padding: 5px;">  <b>NOTICE!</b>  <b>Tighten the screws as shown in the diagram at "9.4.2.2 - Cross diagram for tightening screws".</b> </div>
47	Position the membrane protection grid (17).
48	Put the diaphragm unit (14, 15, 20, 30) in place and lubricate the retaining slots with synthetic grease.
49	Fit the spring (45).
50	Put in the upper cover (4).
51	<b>ONLY VALID FOR 4"</b> Insert and fix the screws (24) according to the following tightening torques: <ul style="list-style-type: none"> <li>• 4" : "Tab. 9.75";</li> <li>• 6" : "Tab. 9.76";</li> <li>• 8" : "Tab. 9.77".</li> </ul> <div style="border: 1px solid blue; padding: 5px;">  <b>NOTICE!</b>  <b>Tighten the screws as shown in the diagram at "9.4.2.2 - Cross diagram for tightening screws".</b> </div>

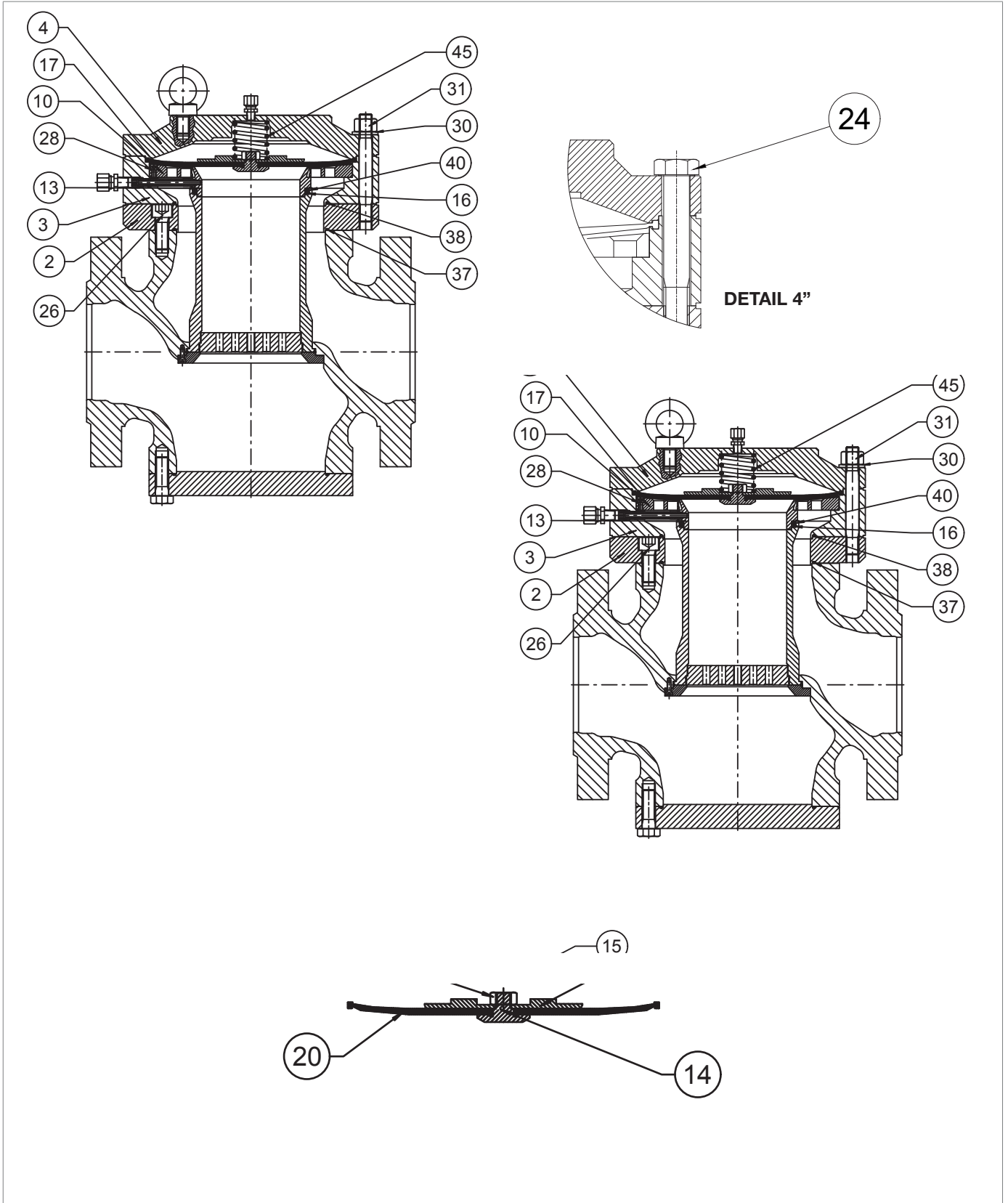

Regulator APERFLUX 851 4" ÷ 8"

Step	Action
52	<p><b>ONLY VALID FOR 6" ÷ 8</b></p> <p>Insert and fix the nuts (31) according to the following tightening torques:</p> <ul style="list-style-type: none"><li>• 4" : "Tab. 9.75";</li><li>• 6" : "Tab. 9.76";</li><li>• 8" : "Tab. 9.77".</li></ul> <p> <b>NOTICE!</b></p> <p><b>Tighten the screws as shown in the diagram at "9.4.2.2 - Cross diagram for tightening screws".</b></p>

Tab. 9.117

 **WARNING!**

**Ensure that all parts have been fitted correctly.**

9.4.3.2 - REGULATOR APERFLUX 851 10"

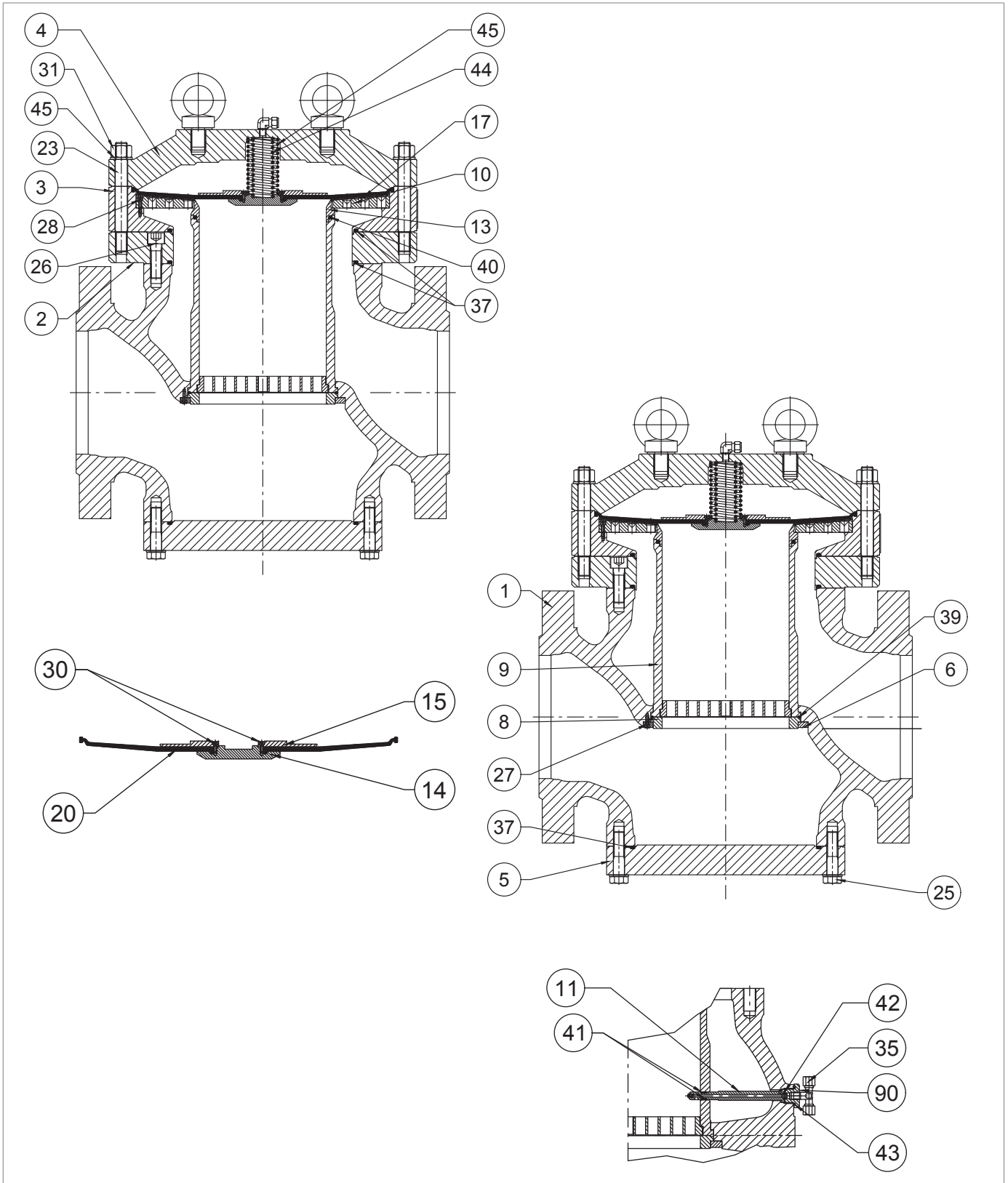





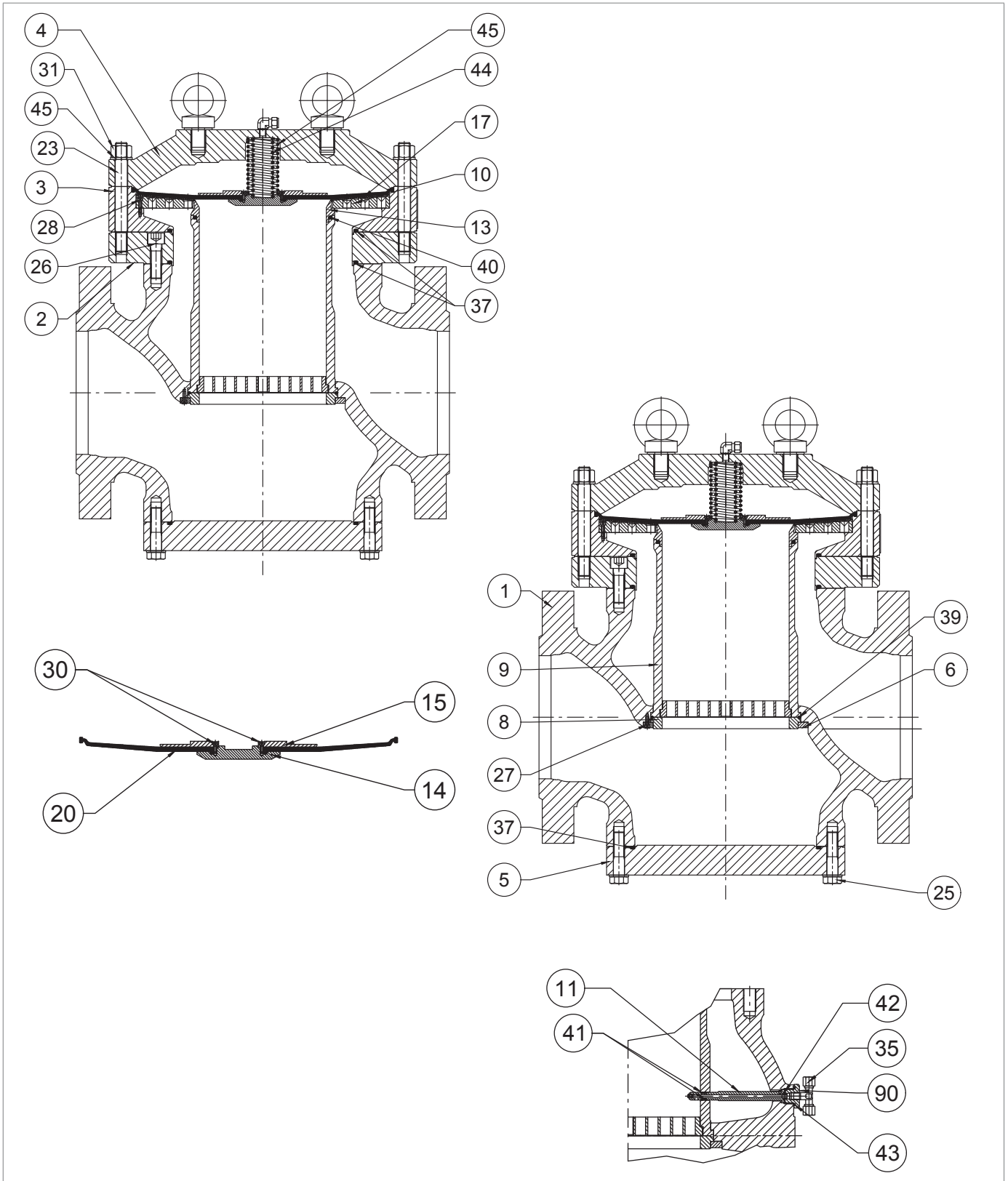

Fig. 9.54. Regulator APERFLUX 851 10"

Step	Action
1	Loosen and remove fixing nuts (31).
2	Remove the upper lid (4).
3	Remove the springs (44, 45).
4	Take out the diaphragm unit (14, 15, 20, 30).
5	Loosen and remove the screws (30)
6	Remove the diaphragm protection disc (15)
7	Remove the diaphragm (20) from the holder (14)
	Replace the diaphragm (20).
8	 <b>NOTICE!</b> <b>Lubricate the lanyard with synthetic grease.</b>
9	Place the diaphragm (20) in the holder (14)
10	Fit the protection disc (15)
11	Insert and fix the screws (30) according to the following tightening torque: <ul style="list-style-type: none"> <li>• 10" : "Tab. 9.78".</li> </ul>
12	Remove the membrane protection grille (17).
13	Undo and remove the screws (28).
14	Remove the grid (10).
	Remove the valve seat (13).
15	 <b>NOTICE!</b> <b>Place it on a shockproof surface to facilitate the operation and to protect it in the event of a fall.</b>
	Remove the O-ring (40) from the valve seat (13) and replace it, lubricating it with synthetic grease.
16	 <b>NOTICE!</b> <b>Before inserting the replacement O-ring, clean the retaining slots with a cleaning solution.</b>
17	Remove the intermediate flange (3).
	Remove the O-ring (37) from the intermediate flange (3) and replace it, lubricating it with synthetic grease.
18	 <b>NOTICE!</b> <b>Before inserting the replacement O-ring, clean the retaining slots with a cleaning solution.</b>
19	Undo and remove the screws (26).
20	Remove the flange (2).
	Remove the O-ring (37) from the flange (2) and replace it, lubricating it with synthetic grease.
21	 <b>NOTICE!</b> <b>Before inserting the replacement O-ring, clean the retaining slots with a cleaning solution.</b>
22	Undo and remove the screws (25).
23	 <b>WARNING!</b> <b>Support the flange to prevent it from falling</b>
24	Remove the blind flange (5).



Regulator APERFLUX 851 10''

Step	Action
25	Remove the O-ring (37) from the blind flange (5) and replace it, lubricating it with synthetic grease. <b>NOTICE!</b> <b>Before inserting the replacement O-ring, clean the retaining slots with a cleaning solution.</b>
26	<b>WARNING!</b> <b>Support the sleeve during the next steps to prevent it from falling.</b> <b>Mark the sleeve with a reference mark in order to reposition it later in the correct manner.</b>
27	Undo and remove the screws (27).
28	Remove the shaft collar (6), the ring (8) and the O-ring (39).
29	Unscrew and remove the feed connection (35).
30	Unscrew and remove the fitting (90).
31	Remove the fitting (11).
32	Remove the O-rings (41, 42) from the fitting (11) and replace them, lubricating them with synthetic grease. <b>NOTICE!</b> <b>Before inserting the replacement O-ring, clean the retaining slots with a cleaning solution.</b>
33	Remove the O-ring (43) from the fitting (90) and replace them, lubricating them with synthetic grease. <b>NOTICE!</b> <b>Before inserting the replacement O-ring, clean the retaining slots with a cleaning solution.</b>
34	Remove the sleeve (9) from the top downwards.
35	Clean the upper and lower bearing surfaces of the body (1) and the flanges (2, 5), the contact surfaces between the sleeve (9), conical seat (8) and the body.
36	Insert the sleeve (9) from bottom upwards. <b>NOTICE!</b> <b>Take care to align the sleeve hole (9) with the body hole.</b>
37	Insert the fitting (11) . <b>NOTICE!</b> <ul style="list-style-type: none"> <li>• <b>Use the fitting (11) as a guide to align sleeve hole and body hole.</b></li> <li>• <b>Take care not to damage the O-rings (41, 42).</b></li> </ul>
38	Replace the O-ring (39) and lubricate it with synthetic grease.
39	Position the ring (8) and the shaft collar (6).
40	Insert and fix the screws (27) according to the following tightening torque: <ul style="list-style-type: none"> <li>• 10" : "Tab. 9.78".</li> </ul> <b>NOTICE!</b> <b>Tighten the screws as shown in the diagram at "9.4.2.2 - Cross diagram for tightening screws".</b>
41	Screw in and secure the fitting (90).
42	Screw in and secure the supply fitting (35), ensuring it is tight in the thread.

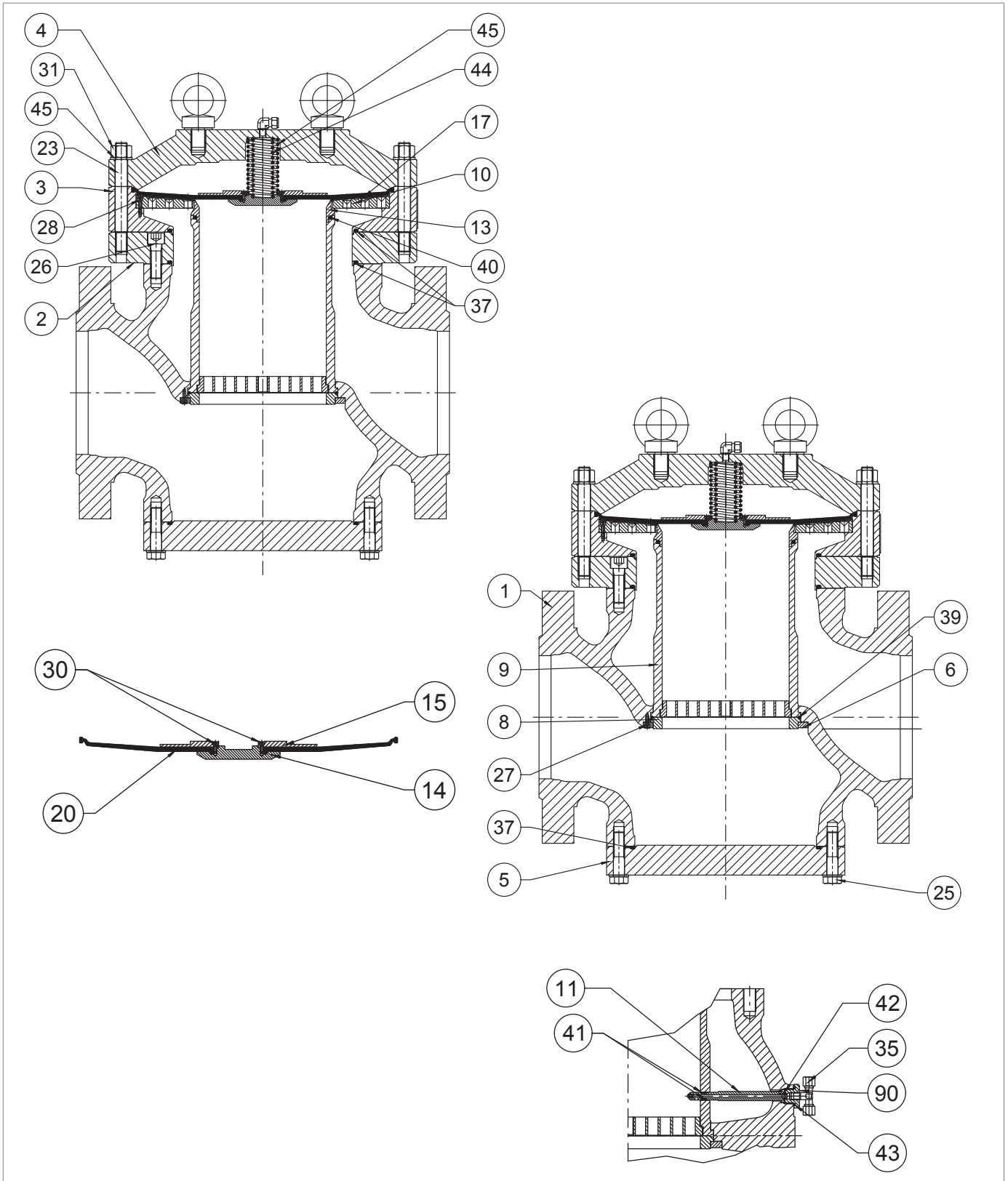

Regulator APERFLUX 851 10''

Step	Action
43	<p><b>! NOTICE!</b></p> <p><b>For the next action, be careful to support the flange during the phase to avoid any possible falls.</b></p>
44	Fit the blind flange (5).
45	<p>Insert and fix the screws (25) according to the following tightening torque:</p> <ul style="list-style-type: none"> <li>10" : "Tab. 9.78".</li> </ul> <p><b>! NOTICE!</b></p> <p><b>Tighten the screws as shown in the diagram at "9.4.2.2 - Cross diagram for tightening screws".</b></p>
46	Fit the flange (2)
47	<p>Insert and fix the screws (26) according to the following tightening torque:</p> <ul style="list-style-type: none"> <li>10" : "Tab. 9.78".</li> </ul> <p><b>! NOTICE!</b></p> <p><b>Tighten the screws as shown in the diagram at "9.4.2.2 - Cross diagram for tightening screws".</b></p>
48	<p>Fit the intermediate flange (3).</p> <p><b>! NOTICE!</b></p> <p><b>Make sure that the supply hole of the AR100 throttle valve faces upstream.</b></p>
49	<p>Insert the valve seat (13) into the sleeve (9).</p> <p><b>! NOTICE!</b></p> <p><b>Take care not to damage the O-ring (40).</b></p>
50	Fit the grid (10).
51	<p>Insert and fix the screws (28) according to the following tightening torque:</p> <ul style="list-style-type: none"> <li>10" : "Tab. 9.78".</li> </ul> <p><b>! NOTICE!</b></p> <p><b>Tighten the screws as shown in the diagram at "9.4.2.2 - Cross diagram for tightening screws".</b></p>
52	Position the membrane protection grid (17).
53	Put the diaphragm unit (14, 15, 20, 30) in place and lubricate the retaining slots with synthetic grease.
54	Position the springs (44, 45).
55	Put in the upper cover (4).
56	<p>Insert and tighten the nuts (31) together with the tie rods (23) according to the tightening torque:</p> <ul style="list-style-type: none"> <li>10" : "Tab. 9.78".</li> </ul> <p><b>! NOTICE!</b></p> <p><b>Tighten the screws as shown in the diagram at "9.4.2.2 - Cross diagram for tightening screws".</b></p>

Tab. 9.118

**! WARNING!**

**Ensure that all parts have been fitted correctly.**

**9.4.4 - MAINTENANCE OF THE 300/A SERIES PILOT + AR100 THROTTLE VALVE**

**9.4.4.1 - 300/A SERIES PILOT DISCONNECTION**

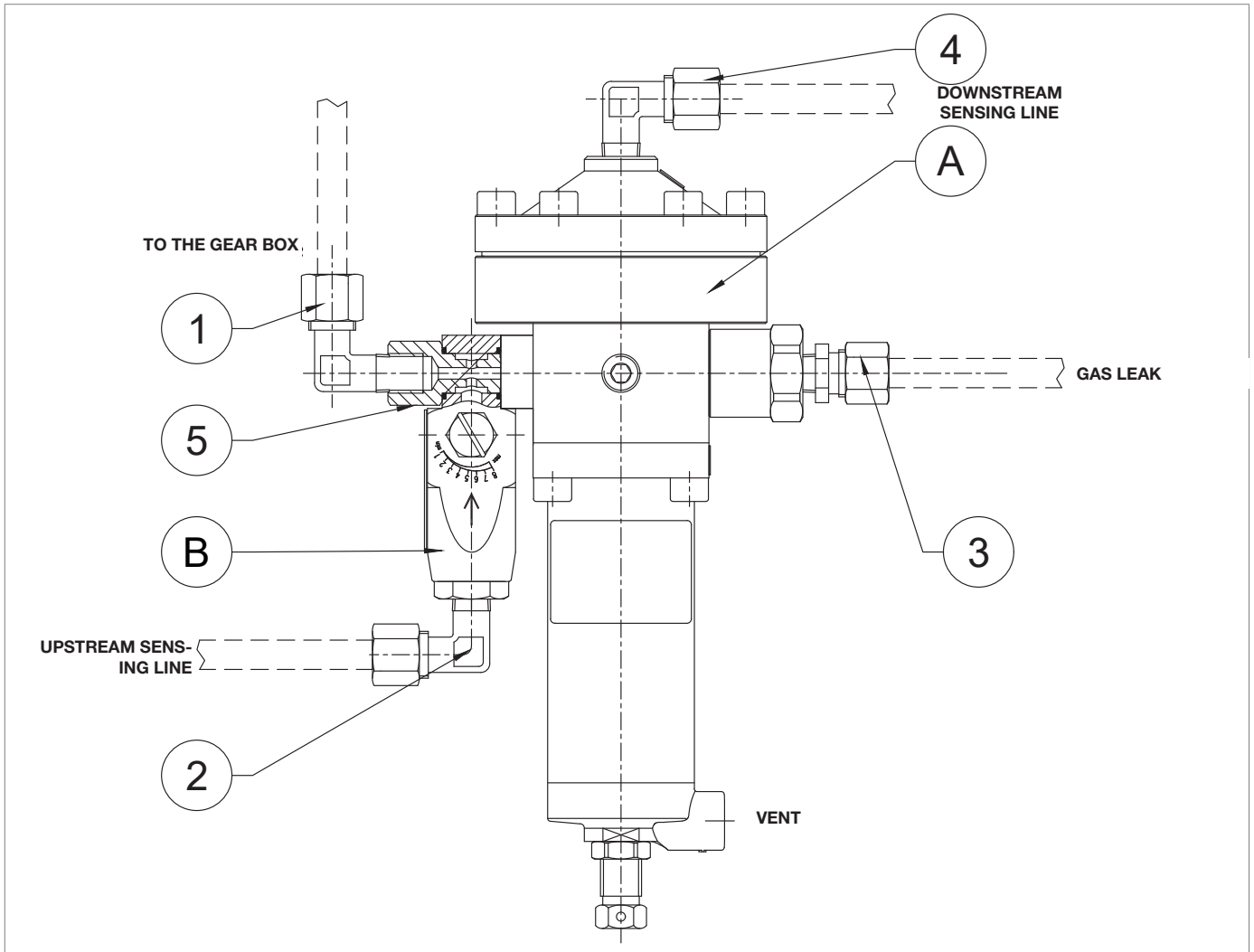

Fig. 9.55. 300/A series pilot

To disconnect, proceed as follows:

Step	Action
<b>1</b>	Disconnect the sensing lines between the 300/A pilot and the regulator by adjusting the fittings (1, 2, 3, 4).
<b>2</b>	Unscrew and remove the fixing screw to remove the pilot from the regulator.
<b>3</b>	Unscrew and remove the screw (5) to separate the AR100 throttle valve from the pilot.

*Tab. 9.119*

To reconnect the pilot, proceed as follows:

Step	Action
<b>1</b>	Insert and secure the screw (5) into the AR100 throttle valve to connect it to the pilot.
<b>2</b>	Insert and fix the fixing screw to connect the pilot to the regulator.
<b>3</b>	Connect the sensing lines between the 300/A pilot and the regulator by adjusting the fittings (1, 2, 3, 4).

*Tab. 9.120*

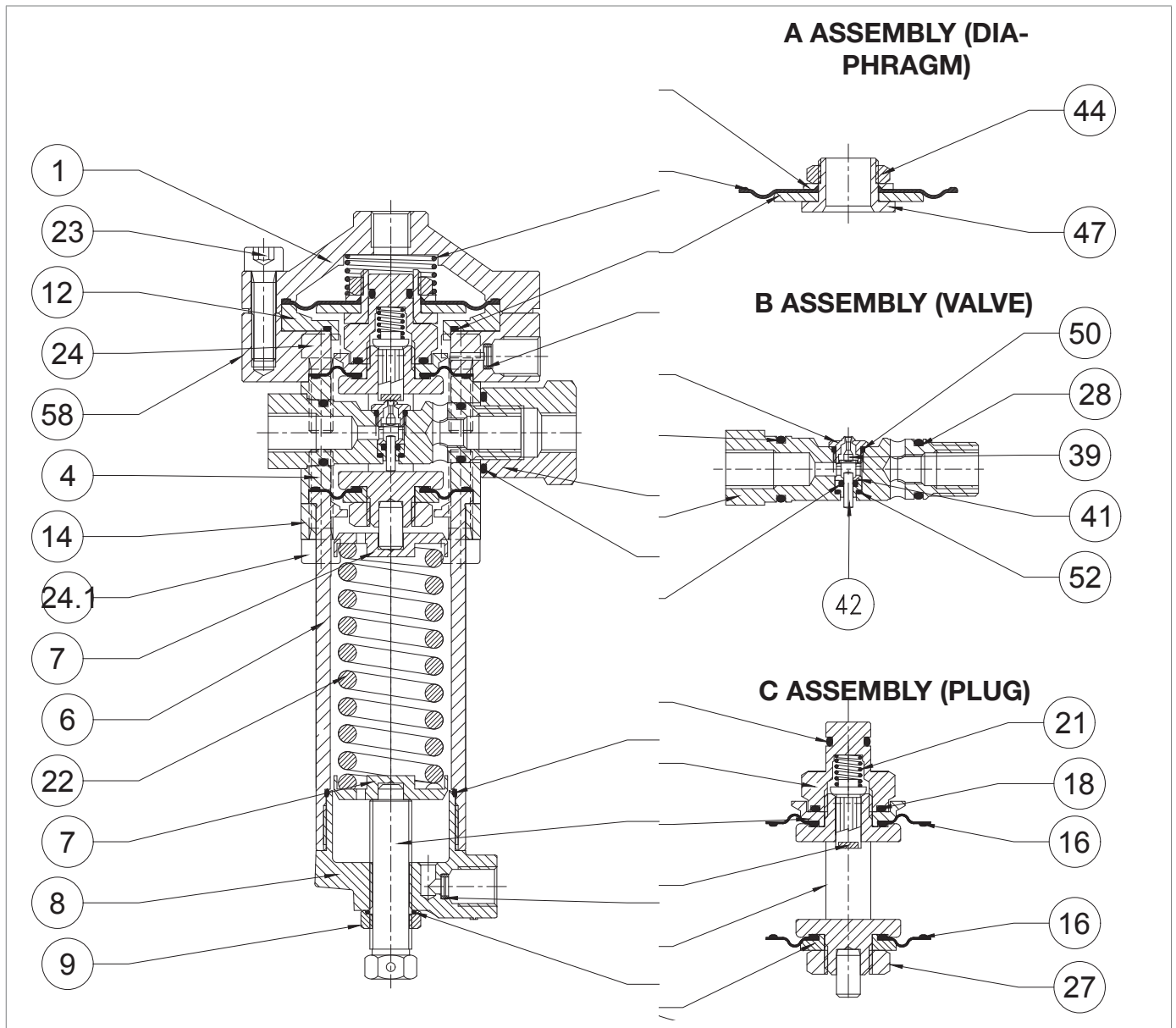





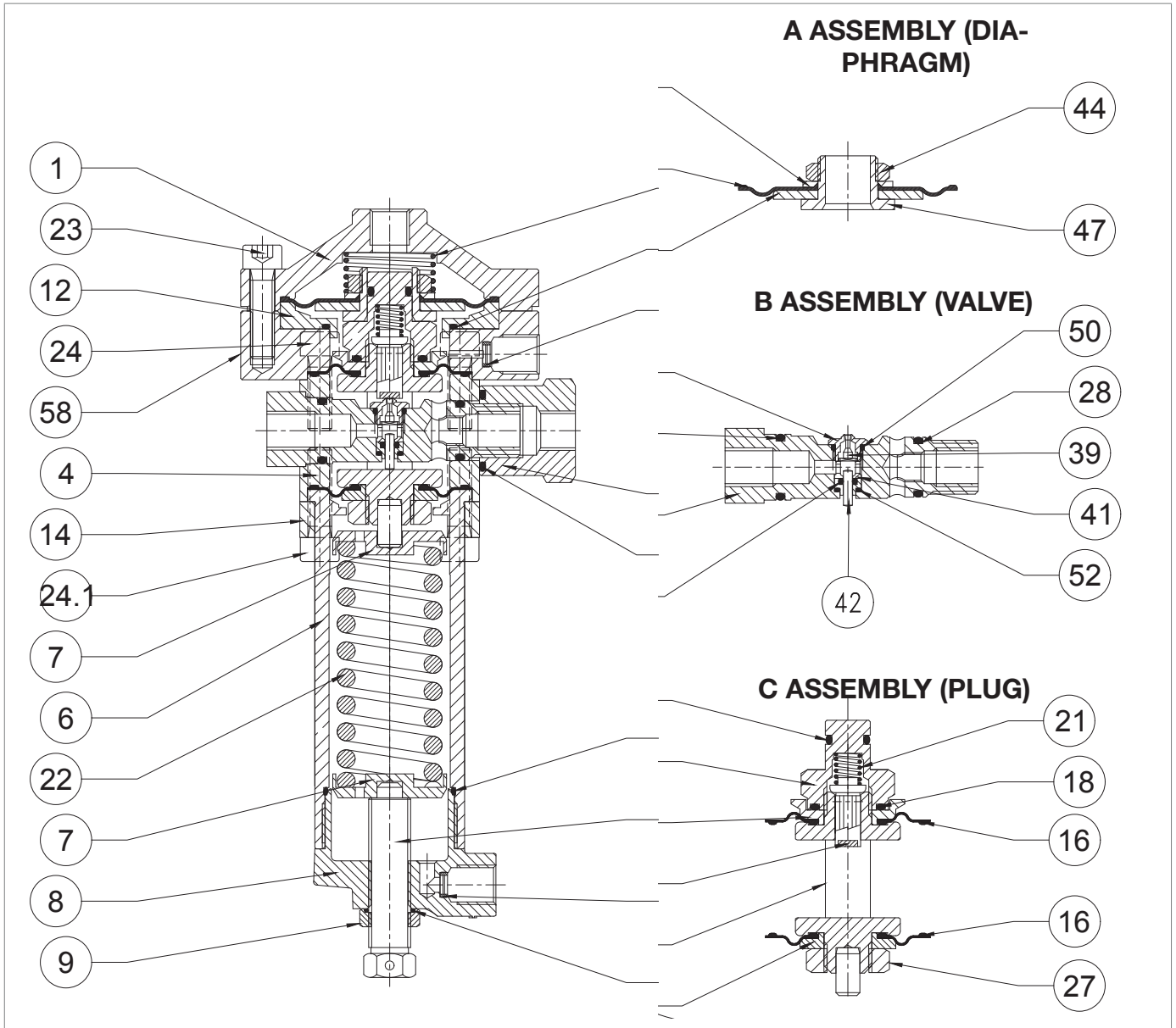

Fig. 9.56. Pilot 302/A

Step	Action
1	Loosen the nut (9).
2	Completely release the spring (22) by turning the adjusting screw (10).
3	Remove the adjusting screw (10) together with the cap (9).
4	Remove the cap (8).
	Remove the O-ring (35) from the cap (8) and replace it, lubricating it with synthetic grease.
5	 <b>NOTICE!</b> <b>Before inserting the replacement O-ring, clean the retaining slots with a cleaning solution.</b>
6	Remove the spring (22) and the spring supports (7).
7	Undo and remove the screws of the lower section (24.1).
8	Remove the bracket (14) from the sleeve (6).
9	Remove the sleeve (6).
10	Undo and remove the screws of the upper section (23).
11	Remove the pilot cover (1).
12	Remove the spring (20).
13	Pull out the "A" assembly (membrane).
14	Unscrew the nut (44).
15	Remove the ring (46).
16	Remove and replace the diaphragm (49) from its support (47), taking care to lubricate the lanyards with synthetic grease.
17	Position the ring (46).
18	Tighten assembly "A" (diaphragm) with the nut (44) according to the tightening torque.
19	Unscrew and remove the nut (26).
	Remove the O-ring (26.1) from the nut (26) and replace it, lubricating it with synthetic grease.
20	 <b>NOTICE!</b> <b>Before inserting the replacement O-ring, clean the retaining slots with a cleaning solution.</b>
21	Remove the ring (12).
	Remove the O-ring (54) from the ring (12) and replace it, taking care to lubricate it with synthetic grease.
22	 <b>NOTICE!</b> <b>Before inserting the replacement O-ring, clean the retaining slots with a cleaning solution.</b>
23	Pull out the "B" (valve) assembly.
	Unscrew the valve seat (38).
24	 <b>NOTICE!</b> <b>Take care not to damage the surfaces</b>
	Remove the O-ring (50) from the valve seat (38) and replace it, lubricating it with synthetic grease.
25	 <b>NOTICE!</b> <b>Before inserting the replacement O-ring, clean the retaining slots with a cleaning solution.</b>
26	Remove the bush (41)



Pilot 302/A

Step	Action
27	Remove the balancing piston (42).
28	Take out the piston guide (40).
29	Remove the O-ring (51) from the piston guide (40) and replace it, lubricating it with synthetic grease. <b>! NOTICE!</b> <b>Before inserting the replacement O-ring, clean the retaining slots with a cleaning solution.</b>
30	Remove the O-ring (52) from the valve seat (3) and replace it, lubricating it with synthetic grease. <b>! NOTICE!</b> <b>Before inserting the replacement O-ring, clean the retaining slots with a cleaning solution.</b>
31	Remove the O-rings (28, 29) from the valve seat (3) and replace them, lubricating them with synthetic grease. <b>! NOTICE!</b> <b>Before inserting the replacement O-ring, clean the retaining slots with a cleaning solution.</b>
32	Fit the piston guide (40) and balancing piston (42).
33	Insert the bush (41) into the pilot seat (3) so that the wider stop rests on the O-ring (51).
34	Insert and fix the valve seat (38). <b>! NOTICE!</b> <b>Take care not to damage the valve seat profile (38) and the O-ring (50).</b>
35	Remove the screws (24) together with the flange (58).
36	Remove assembly "C" (plug) from the valve body (4).
37	Remove the O-ring (53) of the pilot nut (2) and replace it, lubricating it with synthetic grease. <b>! NOTICE!</b> <b>Before inserting the replacement O-ring, clean the retaining slots with a cleaning solution.</b>
38	Unscrew and remove the pilot nut (2).
39	Remove the O-rings (18) from the pilot nut (2) and replace them, taking care to lubricate them with synthetic grease. <b>! NOTICE!</b> <b>Before inserting the replacement O-ring, clean the retaining slots with a cleaning solution.</b>
40	Remove the spring (21).
41	Remove and replace the plug (17).
42	Remove the protective disc (48).
43	Remove and replace the upper diaphragm (16), lubricating the lanyards with synthetic grease. <b>! NOTICE!</b> <b>Before inserting the replacement diaphragm, clean the retaining slots with a cleaning solution.</b>
44	Unscrew and remove the nut (25).
45	Remove the protective disc (15).

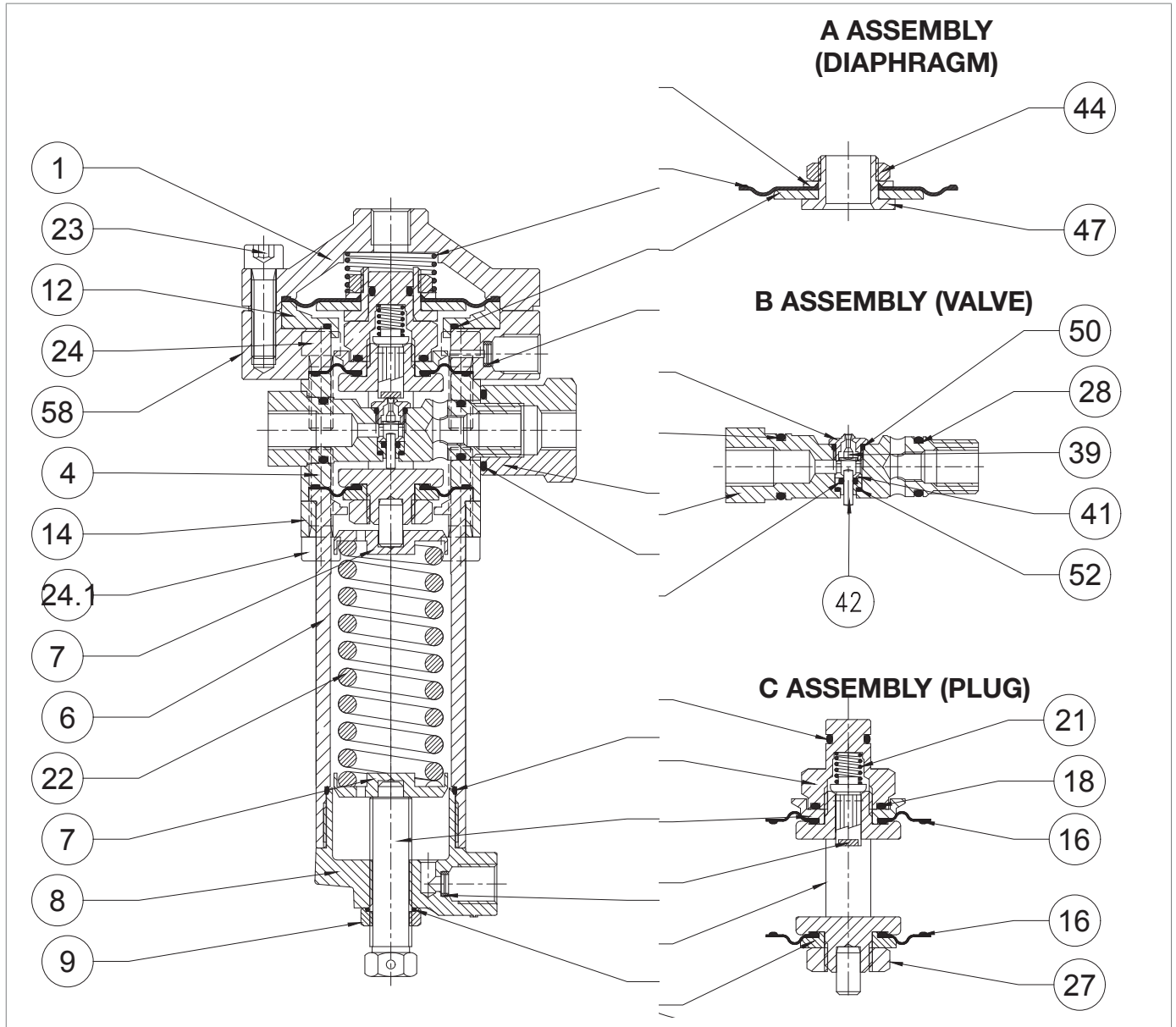

Pilot 302/A

Step	Action
46	Remove and replace the lower diaphragm (16), lubricating the lanyards with synthetic grease. <b>NOTICE!</b> <b>Before inserting the replacement diaphragm, clean the retaining slots with a cleaning solution.</b>
47	Fit the protection disc (15).
48	Fix the nut (25) according to the following tightening torque: • Pilot 302: "Tab. 9.79".
49	Position the plug (17) and the spring (21).
50	Fit the protection disc (48).
51	Fix the nut (2) according to the following tightening torque: • Pilot 302: "Tab. 9.79".
52	Insert assembly "C" (plug) from the top downwards into the valve body (4). <b>NOTICE!</b> • <b>Take care not to damage the diaphragms (16) during this step</b> • <b>The marking on the lower section of the headframe must be parallel to the axis of the hole for inserting the seat (3) into the valve body (4).</b>
53	Insert assembly "B" (valve) into the valve body (4). <b>NOTICE!</b> <b>Take care not to damage the O-rings (28, 29) and the valve seat (3).</b>
54	Screw in the nut (26) according to the following tightening torque: • Pilot 302: "Tab. 9.79".
55	Insert the flange (58).
56	Insert and fix the screws (24) according to the following tightening torque: • Pilot 302: "Tab. 9.79".
57	Position the ring (12).
58	Place the assembly "A" (membrane).
59	Fit the spring (20).
60	Fit the cover (1).
61	Insert and fix the screws (23) according to the following tightening torque: • Pilot 302: "Tab. 9.110".
62	Fit the sleeve (6) and the bracket (14).
63	Insert and fix the screws (24.1) according to the following tightening torque: • Pilot 302: "Tab. 9.79".
64	Fit the spring (22) and the spring supports (7).
65	Unscrew the cap (8).
66	Remove the O-ring (11) from the nut (9) and replace it, lubricating it with synthetic grease. <b>NOTICE!</b> <b>Before inserting the replacement O-ring, clean the retaining slots with a cleaning solution.</b>
67	Fit the adjusting screw (10) together with the cap (9).

Tab. 9.121

**WARNING!**

**Ensure that all parts have been fitted correctly.**

9.4.4.3 - PILOTS 304/A - 305/A

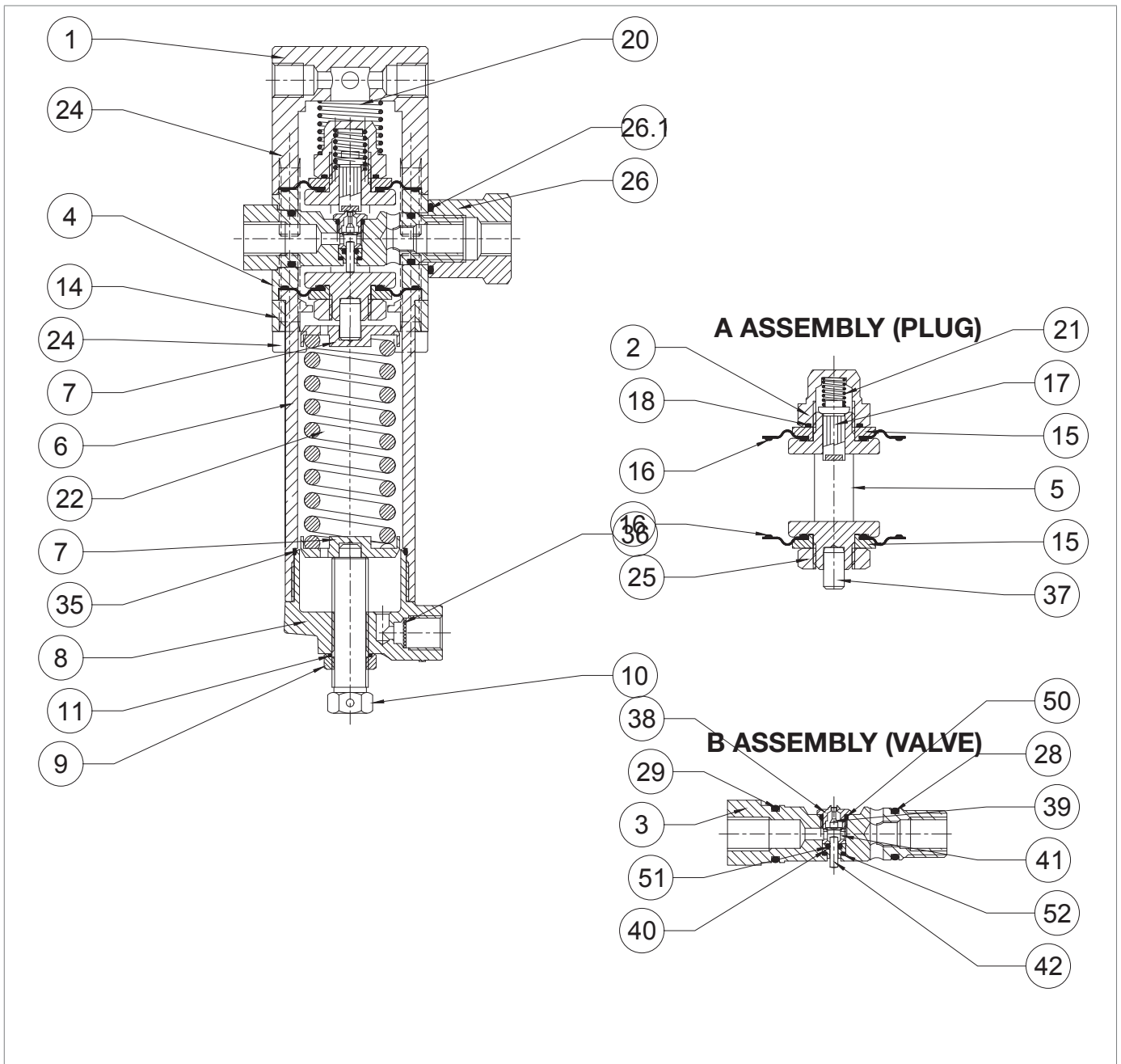





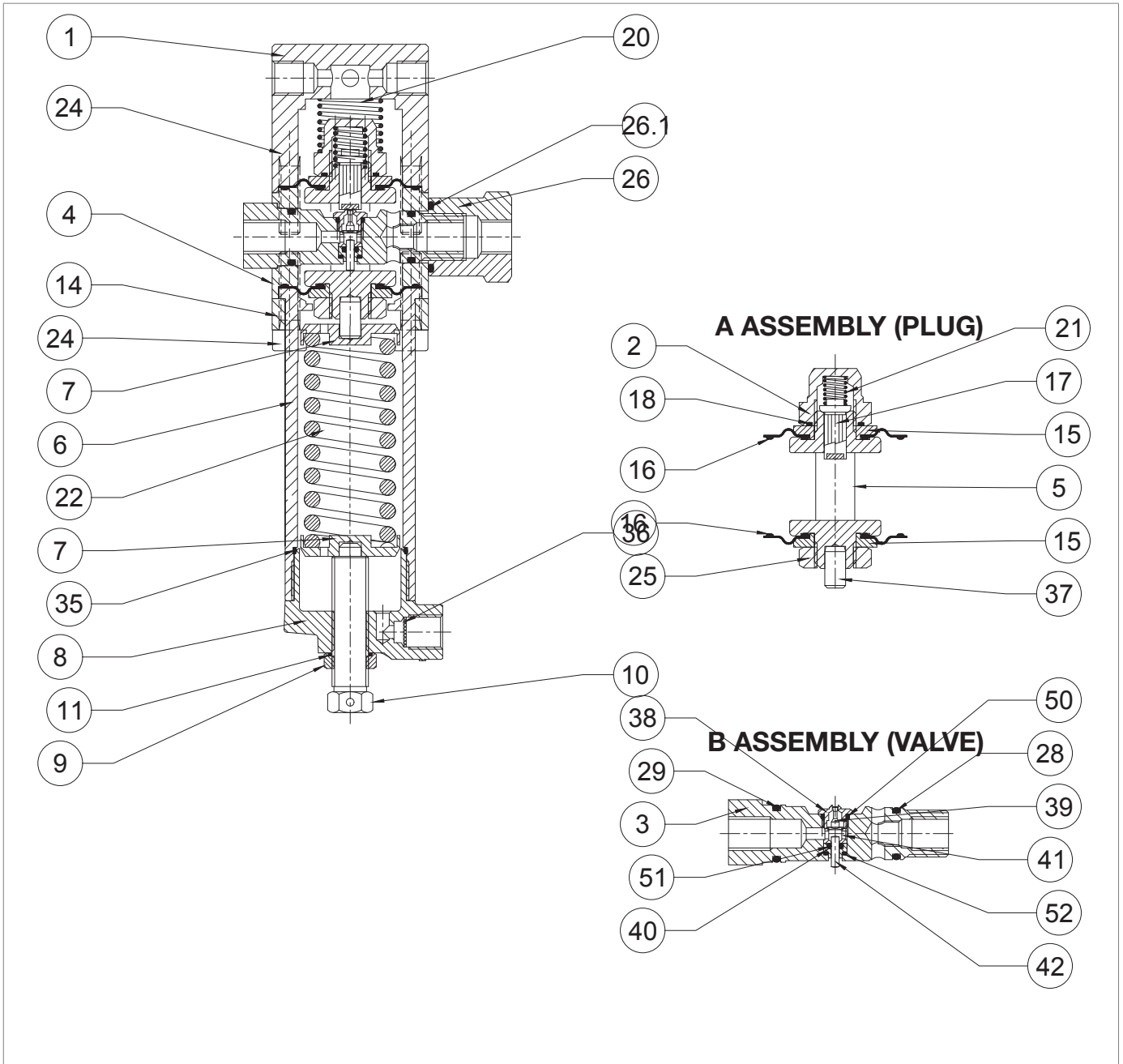

Fig. 9.57. Pilots 304/A - 305/A

Step	Action
1	Loosen the nut (9).
2	Completely release the spring (22) by turning the adjusting screw (10).
3	Remove the adjusting screw (10) together with the cap (9).
4	Unscrew and remove the cap (8).
	Remove the O-ring (35) from the cap (8) and replace it, lubricating it with synthetic grease.
5	 <b>NOTICE!</b> <b>Before inserting the replacement O-ring, clean the retaining slots with a cleaning solution.</b>
6	Remove the spring (22) and the spring supports (7).
7	Undo and remove the screws of the lower section (24).
8	Remove the bracket (14) from the sleeve (6).
9	Remove the sleeve (6).
10	Undo and remove the screws of the upper section (24).
11	Remove the pilot cover (1).
12	Remove the spring (20).
13	Unscrew and remove the nut (26).
	Remove the O-ring (26.1) from the nut (26) and replace it, lubricating it with synthetic grease.
14	 <b>NOTICE!</b> <b>Before inserting the replacement O-ring, clean the retaining slots with a cleaning solution.</b>
15	Pull out the "B" (valve) assembly.
	Unscrew the valve seat (38).
16	 <b>NOTICE!</b> <b>Take care not to damage the surfaces.</b>
	Remove the O-ring (50) from the valve seat (38) and replace it, lubricating it with synthetic grease.
17	 <b>NOTICE!</b> <b>Before inserting the replacement O-ring, clean the retaining slots with a cleaning solution.</b>
18	Remove the bush (41).
19	Remove the balancing piston (42).
20	Take out the piston guide (40).
	Remove the O-ring (51) from the piston guide (40) and replace it, lubricating it with synthetic grease.
21	 <b>NOTICE!</b> <b>Before inserting the replacement O-ring, clean the retaining slots with a cleaning solution.</b>
	Remove the O-rings (28, 29) from the valve seat (38) and replace them, taking care to lubricate them with synthetic grease.
22	 <b>NOTICE!</b> <b>Before inserting the replacement O-ring, clean the retaining slots with a cleaning solution.</b>
23	Fit the piston guide (40) and balancing piston (42).



*Pilots 304/A - 305/A*

Step	Action
24	Insert the bush (41) into the pilot seat (3) so that the wider stop rests on the O-ring (51).
25	Insert and fix the valve seat (38). <b>! NOTICE!</b> <b>Take care not to damage the valve seat profile (38) and the O-ring (50).</b>
26	Remove assembly "A" (plug) from the valve body (4) by pushing it from the top downwards.
27	Unscrew and remove the pilot nut (2).
28	Remove the O-ring (18) of the pilot nut (2) and replace it, lubricating it with synthetic grease. <b>! NOTICE!</b> <b>Before inserting the replacement O-ring, clean the retaining slots with a cleaning solution.</b>
29	Remove the spring (21).
30	Remove and replace the plug (17).
31	Remove the upper protection disc (15).
32	Remove and replace the upper diaphragm (16), lubricating the lanyards with synthetic grease. <b>! NOTICE!</b> <b>Before inserting the replacement diaphragm, clean the retaining slots with a cleaning solution.</b>
33	Unscrew and remove the nut (25).
34	Remove the lower protection disc (15)
35	Remove and replace the lower diaphragm (16), lubricating the lanyards with synthetic grease. <b>! NOTICE!</b> <b>Before inserting the replacement diaphragm, clean the retaining slots with a cleaning solution.</b>
36	Fit the lower protection disc (15).
37	Fix the nut (25) according to the following tightening torque: • Pilots 304-305 : "Tab. 9.80".
38	Position the plug (17) and the spring (21).
39	Fit the upper protection disc (15).
40	Fix the pilot nut (2) according to the following tightening torque: • Pilots 304-305 : "Tab. 9.80".
41	Insert assembly "A" (plug) from top to bottom into the valve body (4). <b>! NOTICE!</b> • <b>Take care not to damage the diaphragms (16) during this step.</b> • <b>The marking on the lower section of the headframe must be parallel to the axis of the hole for inserting the seat (38) into the valve body (4).</b>
42	Insert assembly "B" (valve) into the valve body (4). <b>! NOTICE!</b> • <b>Take care not to damage the O-rings (28, 29) and the valve seat (38).</b> • <b>Insert the assembly with the valve seat (38) facing upwards.</b>
43	Screw in the nut (26) according to the following tightening torque: • Pilots 304-305 : "Tab. 9.80".
44	Fit the spring (20).

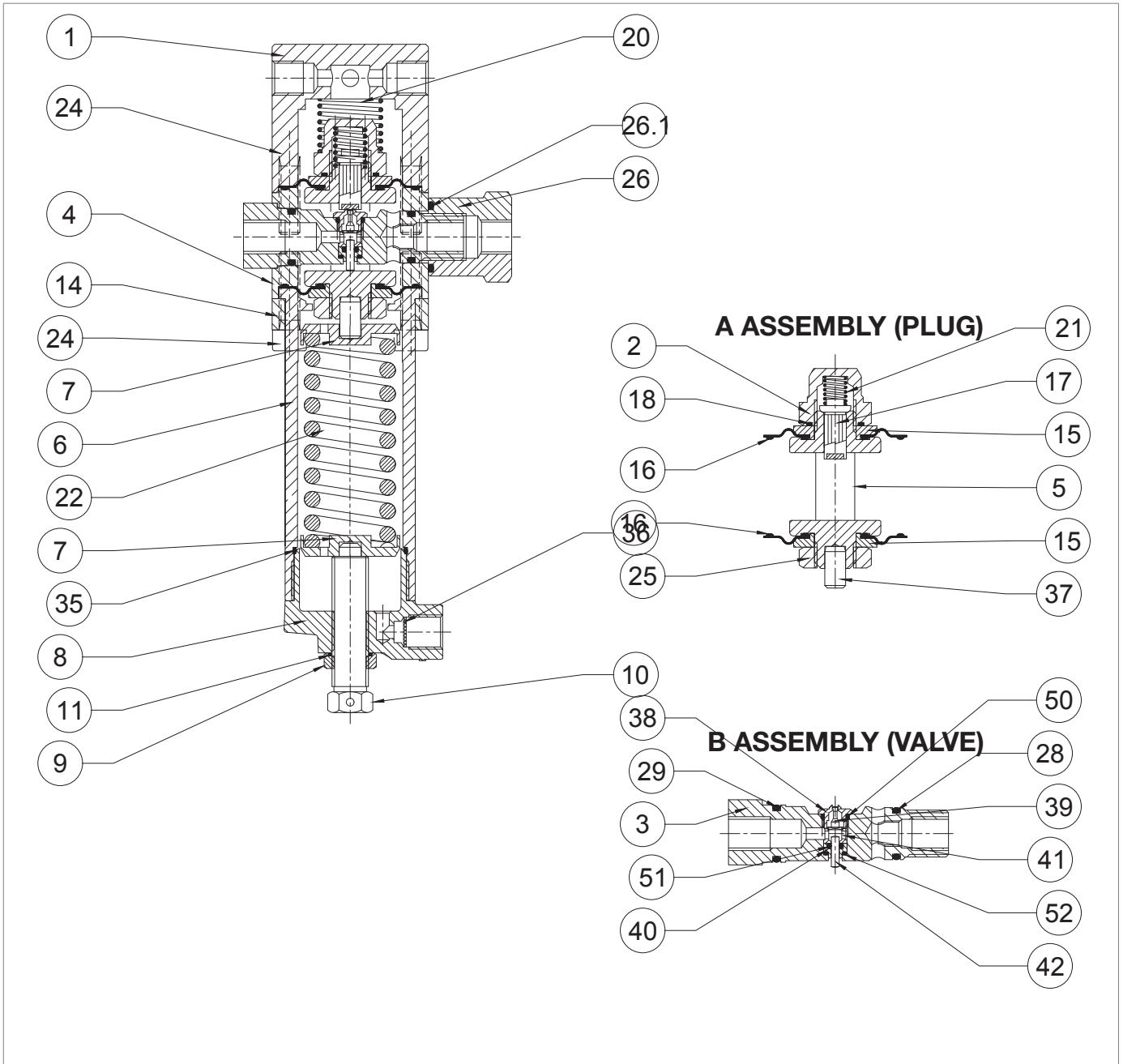

*Pilots 304/A - 305/A*

Step	Action
45	Fit the cover (1).
46	Insert and fix the screws of the upper section (24) according to the following tightening torque: <ul style="list-style-type: none"> <li>• Pilots 304-305 : "Tab. 9.80".</li> </ul>
47	Fit the sleeve (6) and the bracket (14).
48	Insert and fix the screws of the lower section (24) according to the following tightening torque: <ul style="list-style-type: none"> <li>• Pilots 304-305 : "Tab. 9.80"</li> </ul>
49	Fit the spring (22) and the spring supports (7).
50	Unscrew the cap (8).
51	Remove the O-ring (11) from the nut (9) and replace it, lubricating it with synthetic grease. <div style="border: 1px solid black; padding: 5px; margin-top: 5px;"> <p> <b>NOTICE!</b>  <b>Before inserting the replacement O-ring, clean the retaining slots with a cleaning solution.</b></p> </div>
52	Fit the adjusting screw (10) together with the cap (9).

Tab. 9.122

 **WARNING!**

**Ensure that all parts have been fitted correctly.**

9.4.4.4 - PILOT 307/A

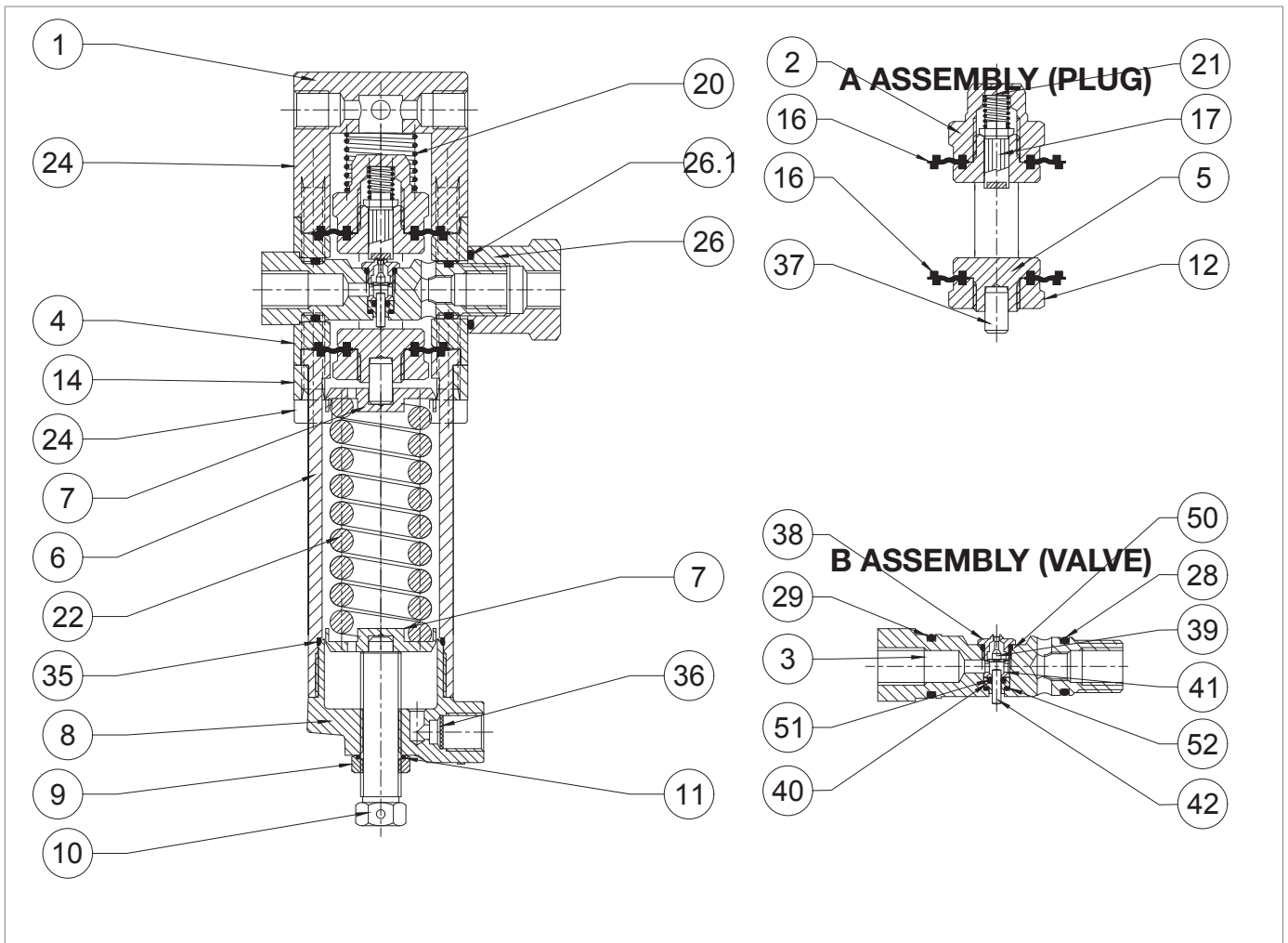





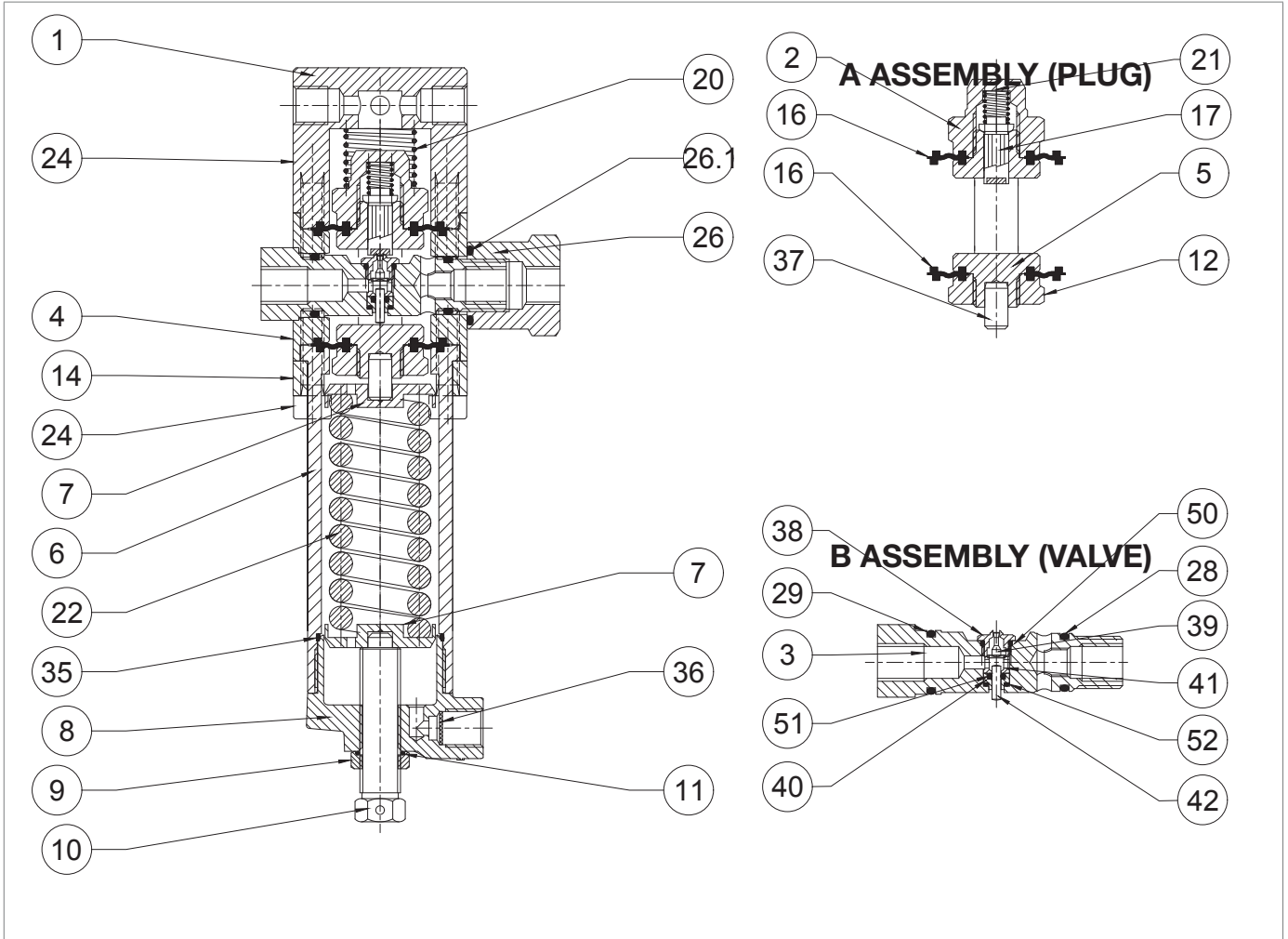

Fig. 9.58. Pilot 307/A

Step	Action
1	Loosen the nut (9).
2	Completely release the spring (22) by turning the adjusting screw (10).
3	Remove the adjusting screw (10) together with the cap (9).
4	Unscrew and remove the cap (8).
	Remove the O-ring (35) from the cap (8) and replace it, lubricating it with synthetic grease.
5	<div style="border: 1px solid blue; padding: 2px;">  <b>NOTICE!</b>  <b>Before inserting the replacement O-ring, clean the retaining slots with a cleaning solution.</b> </div>
6	Remove the spring (22) and the spring supports (7).
7	Undo and remove the screws of the lower section (24).
8	Remove the bracket (14) from the sleeve (6).
9	Remove the sleeve (6).
10	Undo and remove the screws of the upper section (24).
11	Remove the pilot cover (1).
12	Remove the spring (20).
13	Unscrew and remove the pilot nut (2).
14	Remove the spring (21).
15	Remove and replace the plug (17).
16	Remove and replace the upper diaphragm (16).
17	Unscrew and remove the nut (26).
	Remove the O-ring (26.1) from the nut (26) and replace it, lubricating it with synthetic grease.
18	<div style="border: 1px solid blue; padding: 2px;">  <b>NOTICE!</b>  <b>Before inserting the replacement O-ring, clean the retaining slots with a cleaning solution.</b> </div>
19	Pull out the "B" (valve) assembly.
	Unscrew the valve seat (38).
20	<div style="border: 1px solid blue; padding: 2px;">  <b>NOTICE!</b>  <b>Take care not to damage the surfaces.</b> </div>
	Remove the O-ring (50) from the valve seat (38) and replace it, lubricating it with synthetic grease.
21	<div style="border: 1px solid blue; padding: 2px;">  <b>NOTICE!</b>  <b>Before inserting the replacement O-ring, clean the retaining slots with a cleaning solution.</b> </div>
22	Remove the bush (41).
23	Remove the balancing piston (42).
24	Take out the piston guide (40).
	Remove the O-ring (51) from the piston guide (40) and replace it, lubricating it with synthetic grease.
25	<div style="border: 1px solid blue; padding: 2px;">  <b>NOTICE!</b>  <b>Before inserting the replacement O-ring, clean the retaining slots with a cleaning solution.</b> </div>



Pilot 307/A

Step	Action
26	Remove the O-ring (52) from the valve seat (3) and replace it, lubricating it with synthetic grease. <b>NOTICE!</b> <b>Before inserting the replacement O-ring, clean the retaining slots with a cleaning solution.</b>
27	Remove the O-rings (28, 29) from the valve seat (3) and replace them, lubricating them with synthetic grease. <b>NOTICE!</b> <b>Before inserting the replacement O-ring, clean the retaining slots with a cleaning solution.</b>
28	Fit the piston guide (40) and balancing piston (42).
29	Insert the bush (41) into the pilot seat (3) so that the wider stop rests on the O-ring (51).
30	Insert and fix the valve seat (38). <b>NOTICE!</b> <b>Take care not to damage the valve seat profile (38) and the O-ring (50).</b>
31	Remove assembly "A" (plug) from the valve body (4) by pushing it from the top downwards.
32	Unscrew and remove the nut (12).
33	Remove and replace the lower diaphragm (16), lubricating the lanyards with synthetic grease. <b>NOTICE!</b> <b>Before inserting the replacement O-ring, clean the retaining slots with a cleaning solution.</b>
34	Place and fix the nut (12) according to the following tightening torque: • Pilots 307 : "Tab. 9.80".
35	Insert assembly "A" (plug) from top to bottom into the valve body (4). <b>NOTICE!</b> • <b>Take care not to damage the diaphragms (16) during this step;</b> • <b>The marking on the lower section of the headframe must be parallel to the axis of the hole for inserting the seat (3) into the valve body (4).</b>
36	Insert assembly "B" (valve) into the valve body (4). <b>NOTICE!</b> <b>Take care not to damage the O-rings (28, 29) and the valve seat (38).</b>
37	Screw in the nut (26) according to the following tightening torque: • Pilots 307 : "Tab. 9.80".
38	Put the upper diaphragm (16) back in place, taking care to lubricate the lanyards with synthetic grease. <b>NOTICE!</b> <b>Before inserting the replacement diaphragm, clean the retaining slots with a cleaning solution.</b>
39	Position the plug (17) and the spring (21).
40	Place and fix the pilot nut (2) according to the following tightening torque: • Pilots 307 : "Tab. 9.80".
41	Fit the spring (20).
42	Fit the cover (1).

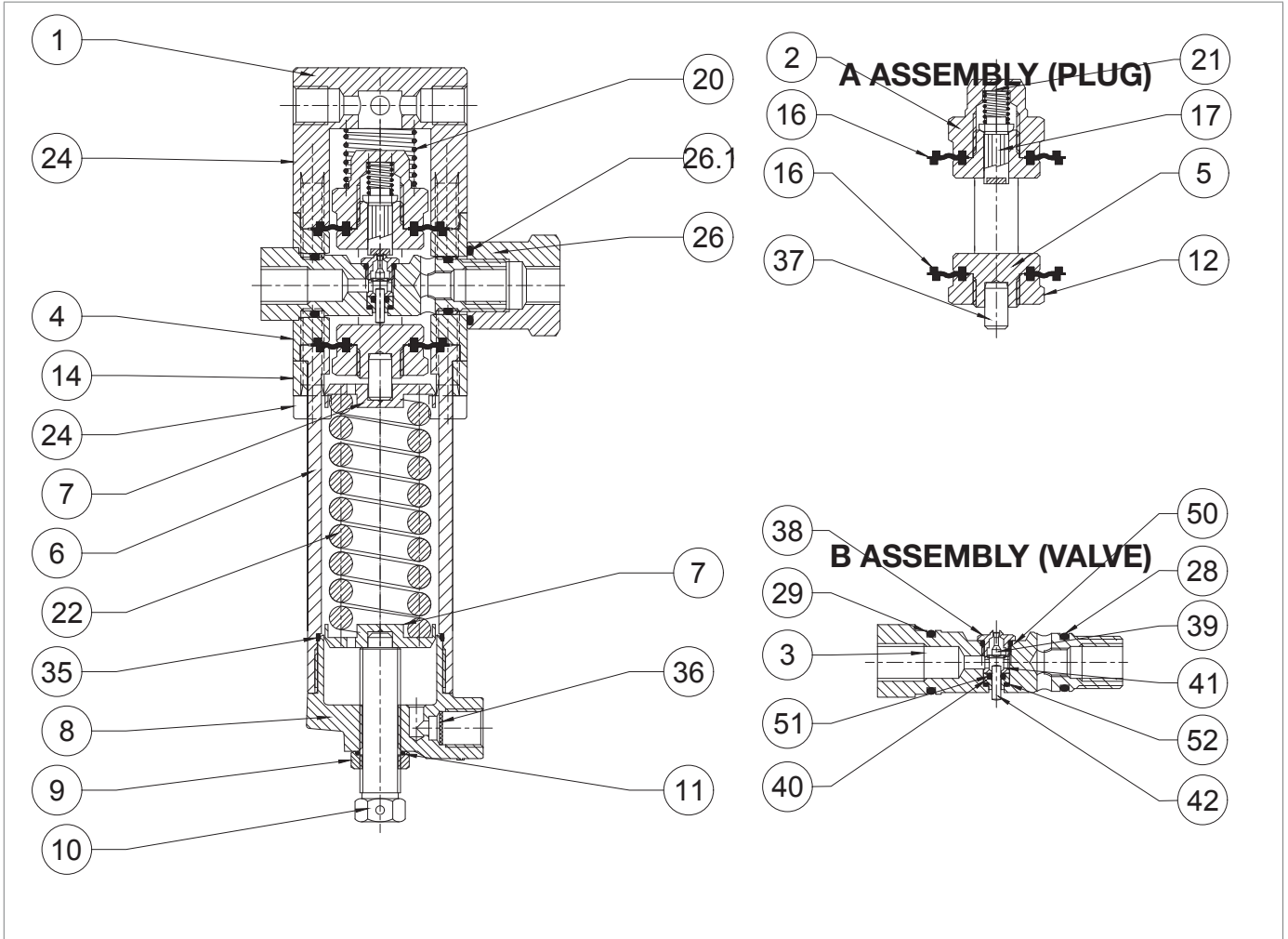

Pilot 307/A

Step	Action
43	Insert and fix the screws of the upper section (24) according to the following tightening torque: <ul style="list-style-type: none"> <li>• Pilots 307 : “Tab. 9.80”.</li> </ul>
44	Fit the sleeve (6) and the bracket (14).
45	Insert and fix the screws of the lower section (24) according to the following tightening torque: <ul style="list-style-type: none"> <li>• Pilots 307 : “Tab. 9.80”.</li> </ul>
46	Fit the spring (22) and the spring supports (7).
47	Unscrew the cap (8).
48	Remove the O-ring (11) from the nut (9) and replace it, lubricating it with synthetic grease. <div style="border: 1px solid blue; padding: 5px; margin-top: 5px;"> <p> <b>NOTICE!</b>  <b>Before inserting the replacement O-ring, clean the retaining slots with a cleaning solution.</b></p> </div>
49	Fit the adjusting screw (10) together with the cap (9).

Tab. 9.123

 **WARNING!**

**Ensure that all parts have been fitted correctly.**

#### 9.4.4.5 - 300/A SERIES PILOT RECONNECTION

 **NOTICE!**

**To reconnect the pilot to the regulator, refer to the “Tab. 9.120”.**





**9.4.4.6 - AR100 THROTTLE VALVE**

Fig. 9.59. AR100 throttle valve

Step	Action
1	Undo and remove the locking screw (97).
2	Remove the O-rings (96) from the AR100 throttle valve body (1) and replace them, lubricating them with synthetic grease. <b>NOTICE!</b> <b>Before inserting the replacement O-rings, clean the retaining slots with a cleaning solution.</b>
3	Undo and remove the locking screw (4).
4	Remove the O-ring (7) from the shut-off screw (4) and replace it, lubricating it with synthetic grease. <b>NOTICE!</b> <b>Before inserting the replacement O-ring, clean the retaining slots with a cleaning solution.</b>
5	Remove the adjusting screw (3).
6	Remove the O-ring (7) from the adjusting screw (3) and replace it, lubricating it with synthetic grease. <b>NOTICE!</b> <b>Before inserting the replacement O-ring, clean the retaining slots with a cleaning solution.</b>
7	Unscrew and remove the cap (2).

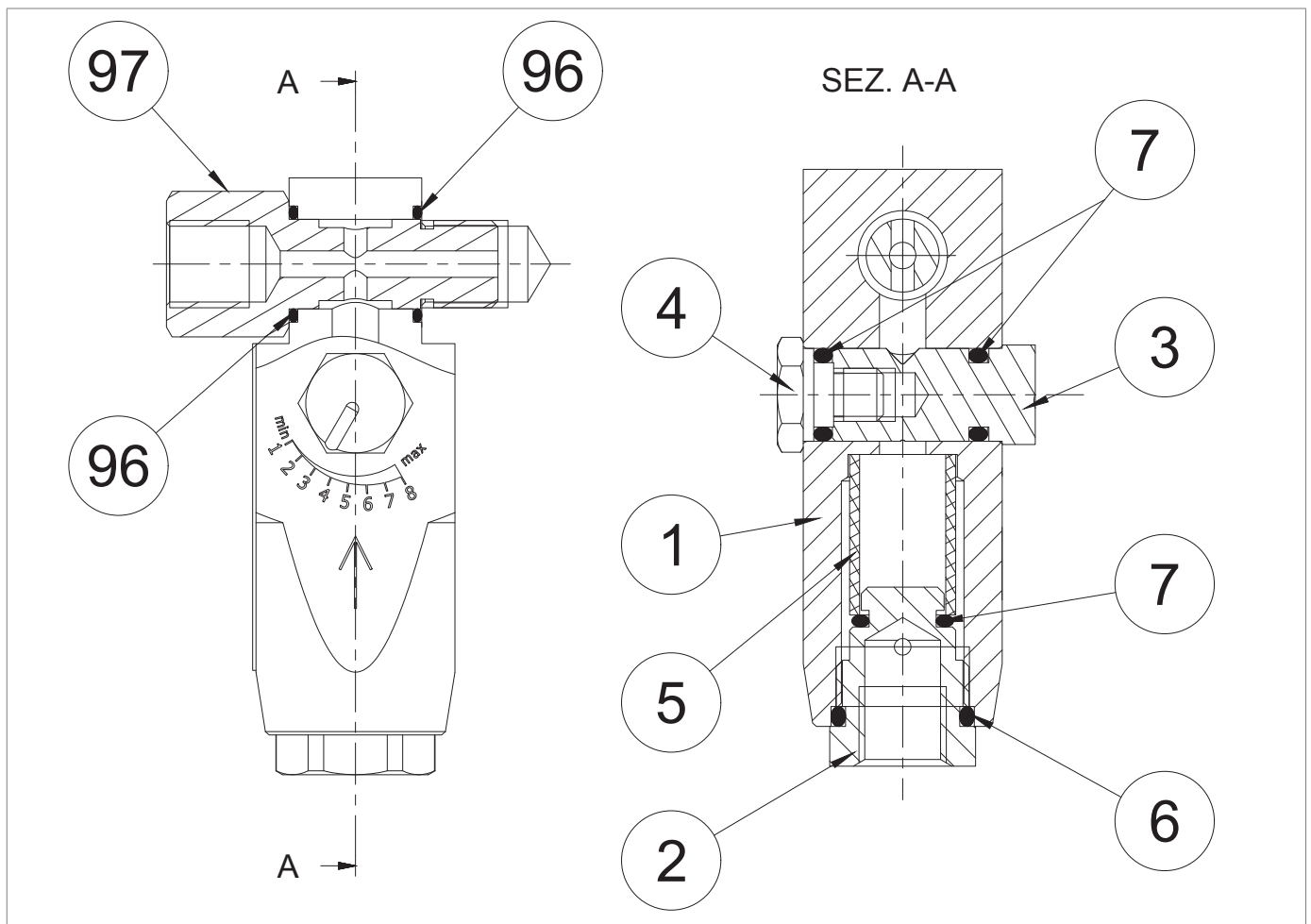
Step	Action
8	Remove the O-rings (6, 7) from the cap (2) and replace them, lubricating them with synthetic grease. <div style="border: 1px solid blue; padding: 5px;">  <b>NOTICE!</b>  <b>Before inserting the replacement O-rings, clean the retaining slots with a cleaning solution.</b> </div>
9	Remove and replace the filter (5).
10	Fit and fix the cap (2) according to the following tightening torque: <ul style="list-style-type: none"> <li>AR100: "Tab. 9.81".</li> </ul> <div style="border: 1px solid blue; padding: 5px;">  <b>NOTICE!</b>  <b>Take care not to damage the O-rings (6, 7).</b> </div>
11	Insert the adjusting screw (3), taking care not to damage the O-ring (7).
12	Fit and fix the shut-off screw (4) according to the following tightening torque: <ul style="list-style-type: none"> <li>AR100: "Tab. 9.81".</li> </ul> <div style="border: 1px solid blue; padding: 5px;">  <b>NOTICE!</b>  <b>Take care not to damage the O-ring (7).</b> </div>
13	Insert the locking screw (97) with the valve ports in line with the AR100 throttle valve (1) body.

Tab. 9.124

 **WARNING!**

Ensure that all parts have been fitted correctly.

#### 9.4.4.7 - ASSEMBLING THE PILOT UNIT

Step	Action
1	Screw in the conical seal fittings to connect the connecting sockets between the 300 series pilot and the AR100 throttle valve.

Tab. 9.125

#### 9.4.4.8 - FINAL OPERATIONS

Step	Action
1	Mount the 300 series pilot assembly + AR100 throttle valve on the regulator.
2	Fasten the nut securing the pilot support bracket to the regulator.
3	Screw the conical seal fittings to reconnect all power outlets and sensing lines for the pilot and regulator.

Tab. 9.126

**9.4.5 - DB/851 SILENCER MAINTENANCE**

**9.4.5.1 - SILENCER DB/851 1"÷ 3"**

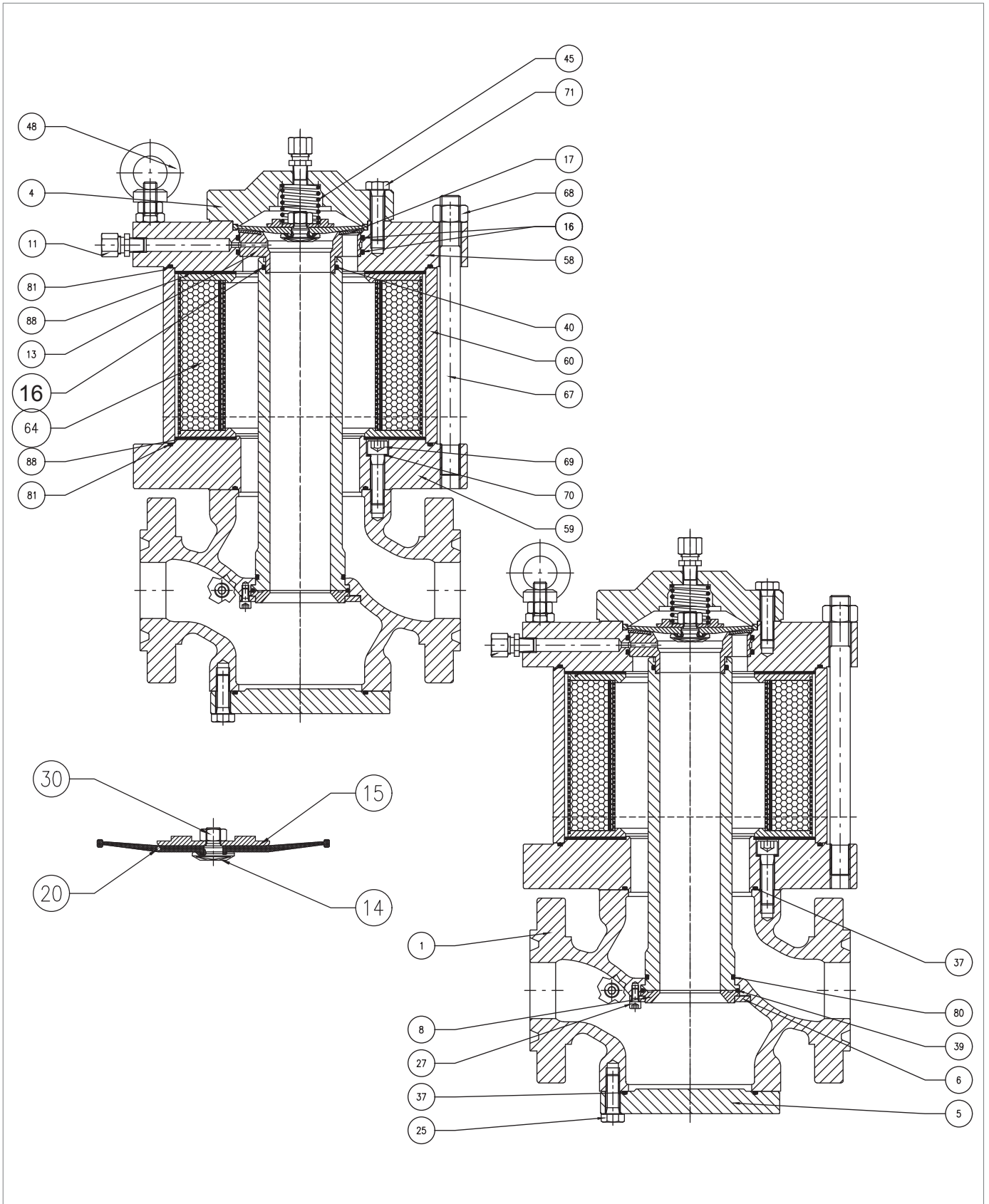





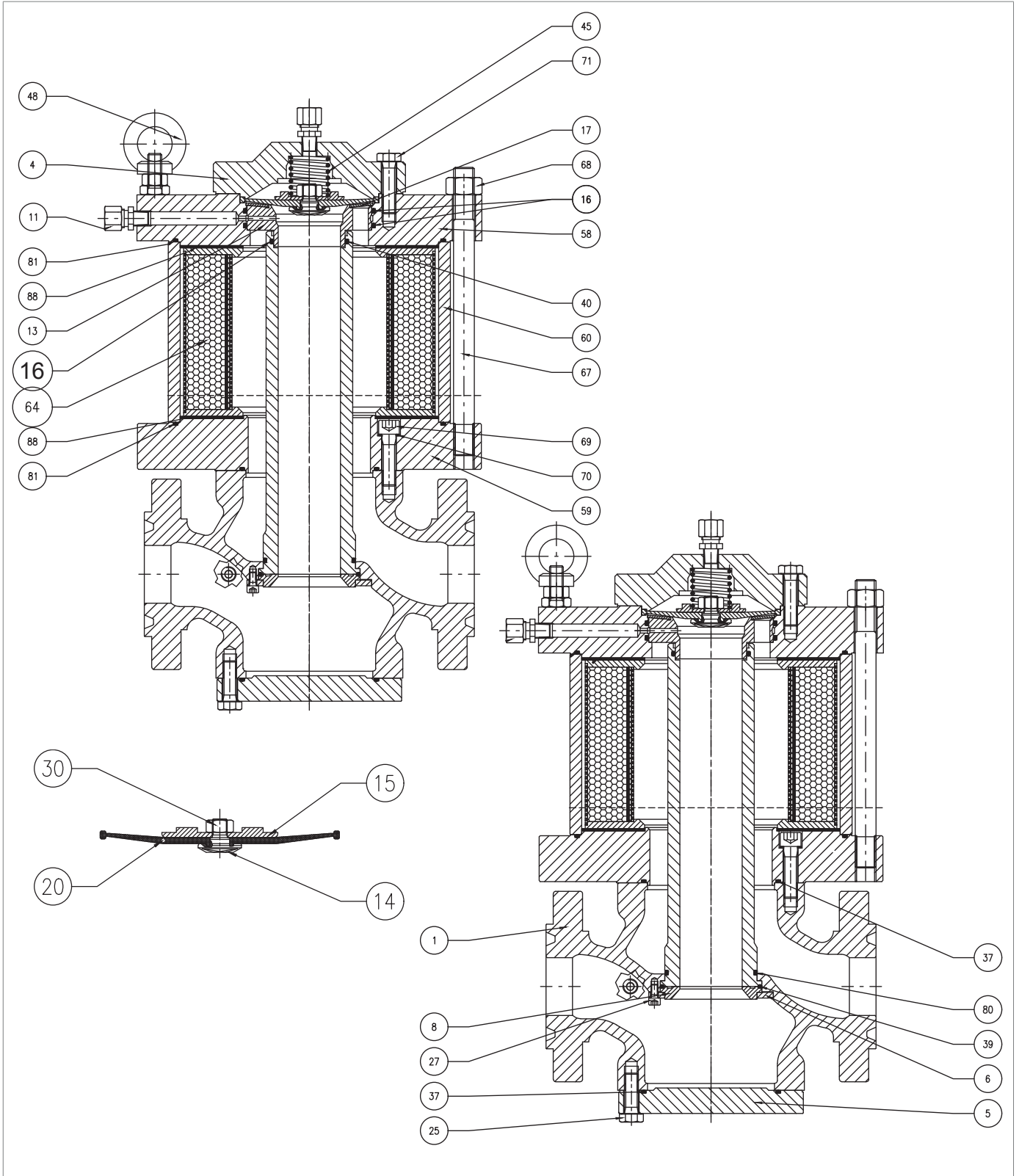

Fig. 9.60. Silencer DB/851 1" - 3"

Step	Action
1	Loosen the eyebolt (48) and fixing screws (71).
2	Remove the upper lid (4).
3	Remove the spring (45).
4	Take out the diaphragm unit (14, 15, 20, 30).
5	Remove the membrane protection grille (17).
6	Unscrew and remove the nut (68).
7	Remove the upper flange (58) together with the valve seat (13).
8	Turn the upper flange (58) upside down.
	Remove the valve seat (13).
9	 <b>NOTICE!</b> <b>Place it on a shockproof surface to facilitate the operation and to protect it in the event of a fall.</b>
	Remove the O-rings (16) from the upper flange (58) and replace them, taking care to lubricate them with synthetic grease.
10	 <b>NOTICE!</b> <b>Before inserting the replacement O-ring, clean the retaining slots with a cleaning solution.</b>
	Remove the O-ring (81) from the upper flange (58) and replace it, lubricating it with synthetic grease.
11	 <b>NOTICE!</b> <b>Before inserting the replacement O-ring, clean the retaining slots with a cleaning solution.</b>
12	Remove and replace the upper anti-oil gasket (88).
13	Remove the basket (64).
14	Remove the plating (60).
	Remove the O-ring (81) from the lower flange (59) and replace it, lubricating it with synthetic grease.
15	 <b>NOTICE!</b> <b>Before inserting the replacement O-ring, clean the retaining slots with a cleaning solution.</b>
16	Remove and replace the lower anti-oil gasket (88).
17	Undo the screws (69) together with the washers (70).
18	Remove the lower flange (59) together with the tie rods (67).
	Remove the O-ring (37) from the lower flange (59) and replace it, lubricating it with synthetic grease.
19	 <b>NOTICE!</b> <b>Before inserting the replacement O-ring, clean the retaining slots with a cleaning solution.</b>
20	Undo and remove the screws (25).
21	Remove the blind flange (5) or any built-in accessory (SB/82 slam-shut valve or PM/819 monitor).
	Remove and replace the O-ring (37) from the blind flange (5) or any built-in accessory (SB/82 slam shut valve or PM/819 monitor), lubricating it with synthetic grease.
22	 <b>NOTICE!</b> <b>Before inserting the replacement O-ring, clean the retaining slots with a cleaning solution.</b>





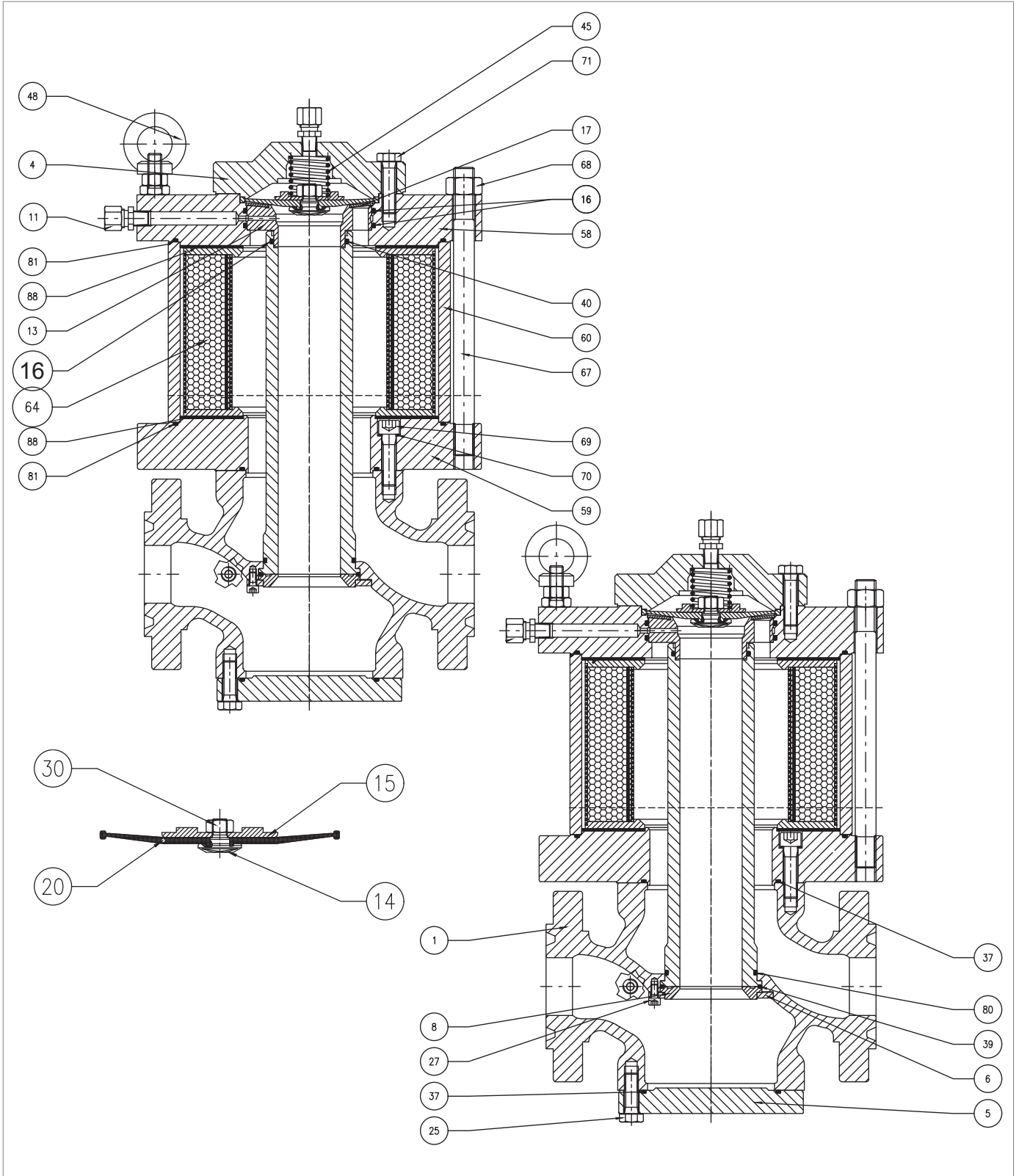

*Silencer DB/851 1" - 3"*

Step	Action
23	Undo and remove the screws (27). <b>NOTICE!</b> <b>During this operation, be careful to support the sleeve.</b>
24	Remove the shaft collar (6) together with the conical seat (8).
25	Remove the sleeve (63) from the top downwards.
26	Remove the O-ring (39) from the conical seat (8) and replace it, lubricating it with synthetic grease. <b>NOTICE!</b> <b>Before inserting the replacement O-ring, clean the retaining slots with a cleaning solution.</b>
27	Remove the O-rings (40, 80) from the sleeve (63) and replace them, taking care to lubricate them with synthetic grease. <b>NOTICE!</b> <b>Before inserting the replacement O-rings, clean the retaining slots with a cleaning solution.</b>
28	Clean the upper and lower bearing surfaces of the body (1) and the flanges (2, 5), the contact surfaces between the sleeve (63), conical seat (8) and the body.
29	Reposition the sleeve (63) in the body from the bottom upwards, supporting it
30	Replace the conical seat (8) together with the O-ring (39) and the shaft collar (6). <b>NOTICE!</b> <b>As an alternative to the conical seat (8), a reinforced gasket may be present, based on the built-in accessory.</b>
31	Insert and fix the screws (27) according to the following tightening torques: <ul style="list-style-type: none"> <li>• 1" : "Tab. 9.82";</li> <li>• 2" : "Tab. 9.83";</li> <li>• 3" : "Tab. 9.84".</li> </ul> <b>NOTICE!</b> <b>Tighten the screws as shown in the diagram at "9.4.2.2 - Cross diagram for tightening screws".</b>
32	Fit the blind flange (5) or any accessory.
33	Insert and fix the screws (25) according to the following tightening torques: <ul style="list-style-type: none"> <li>• 1" : "Tab. 9.82";</li> <li>• 2" : "Tab. 9.83";</li> <li>• 3" : "Tab. 9.84".</li> </ul> <b>NOTICE!</b> <b>Tighten the screws as shown in the diagram at "9.4.2.2 - Cross diagram for tightening screws".</b>
34	Fit the lower flange (59) together with the tie rods (67).
35	<b>NOTICE!</b> <b>Replace the washers (70) before performing this operation.</b>
36	Insert the washers (70) and lubricate them with synthetic grease.



*Silencer DB/851 1" - 3"*

Step	Action
37	Insert and fix the screws (69) according to the following tightening torques: <ul style="list-style-type: none"> <li>1" : "Tab. 9.82";</li> <li>2" : "Tab. 9.83";</li> <li>3" : "Tab. 9.84".</li> </ul> <div style="border: 1px solid blue; padding: 5px; margin-top: 10px;">  <b>NOTICE!</b>  <b>Tighten the screws as shown in the diagram at "9.4.2.2 - Cross diagram for tightening screws".</b> </div>
38	Fit the lower anti-oil gasket (88).
39	Fit the plating (60).
40	Fit the basket (64).
41	Fit the upper anti-oil gasket (88).
42	Fit the upper flange (58). <div style="border: 1px solid blue; padding: 5px; margin-top: 10px;">  <b>NOTICE!</b>  <b>Take care that the AR100's power connection faces upstream.</b> </div>
43	Fit and fix the nuts (68) according to the following tightening torques: <ul style="list-style-type: none"> <li>1" : "Tab. 9.82";</li> <li>2" : "Tab. 9.83";</li> <li>3" : "Tab. 9.84".</li> </ul> <div style="border: 1px solid blue; padding: 5px; margin-top: 10px;">  <b>NOTICE!</b>  <b>Tighten the screws as shown in the diagram at "9.4.2.2 - Cross diagram for tightening screws".</b> </div>
44	Insert the valve seat (13) into the upper flange (58).
45	Position the membrane protection grid (17).
46	Put the diaphragm unit (14, 15, 20, 30) in place.
47	Fit the spring (45).
48	Fit the lid (4).
49	Fit and fix the screws (71) according to the following tightening torques: <ul style="list-style-type: none"> <li>1" : "Tab. 9.82";</li> <li>2" : "Tab. 9.83";</li> <li>3" : "Tab. 9.84".</li> </ul> <div style="border: 1px solid blue; padding: 5px; margin-top: 10px;">  <b>NOTICE!</b>  <b>Tighten the screws as shown in the diagram at "9.4.2.2 - Cross diagram for tightening screws".</b> </div>
50	Put the eyebolt (48) back in place.

Tab. 9.127

 **NOTICE!**  
**For the replacement of O-rings not mentioned in this procedure, please refer to the maintenance leaflet "APERFLUX 851 1" ÷ 3".**

 **WARNING!**  
**Ensure that all parts have been fitted correctly.**

9.4.5.2 - SILENCER DB/851 4" ÷ 10"

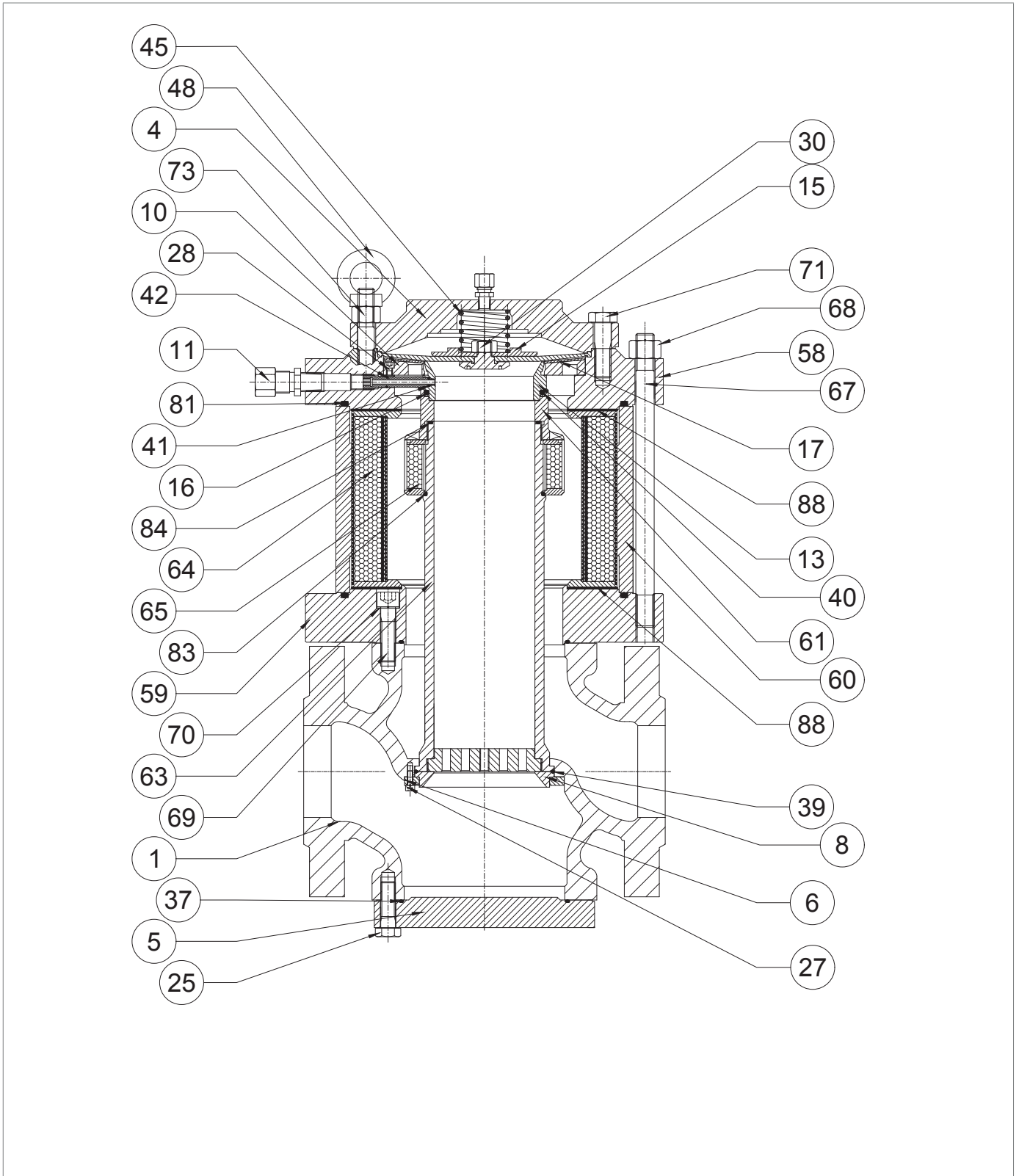
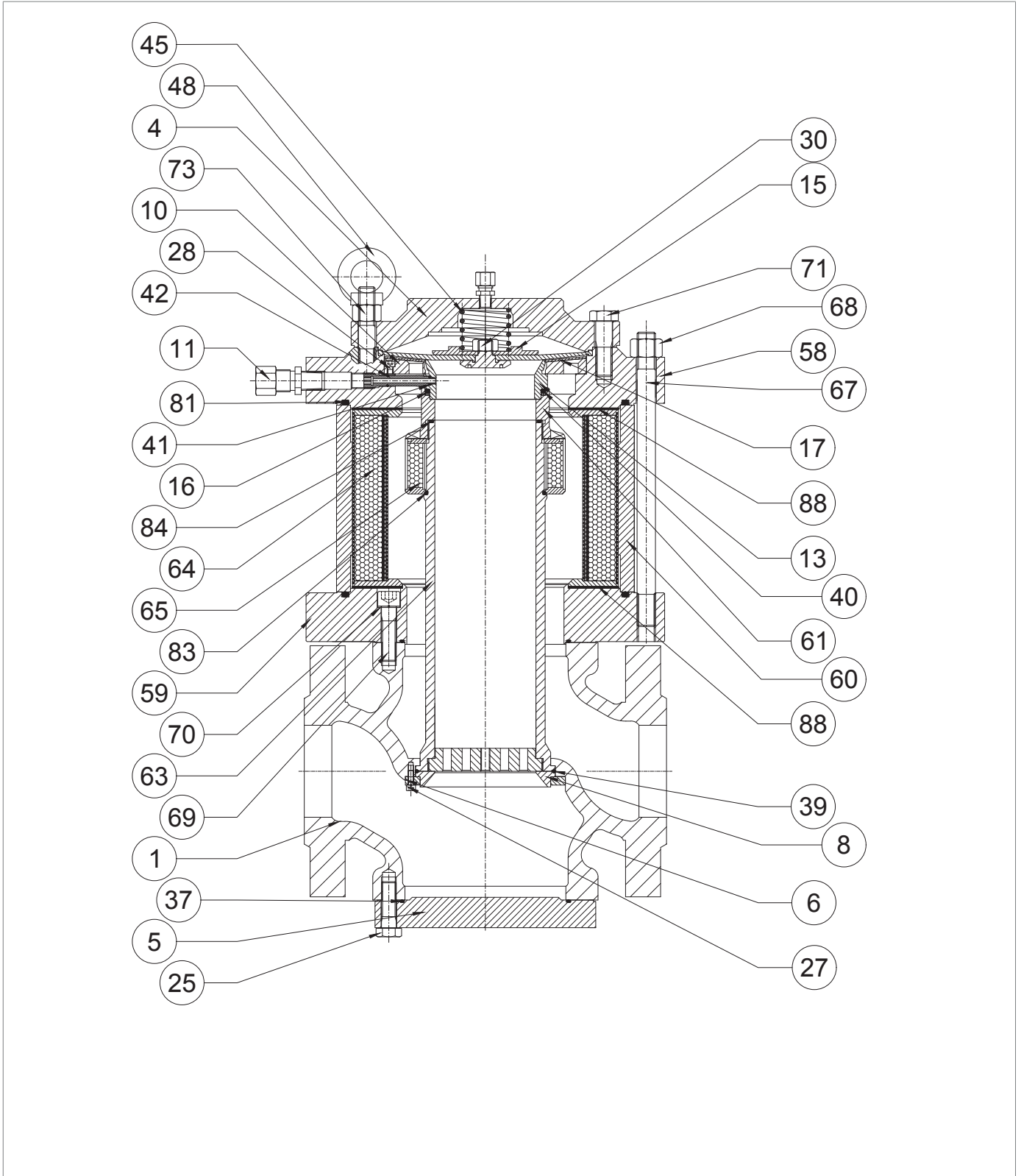

Fig. 9.61. Silencer DB/851 4" - 10"

Step	Action
1	<p><b>a - ONLY VALID FOR 4"</b> Remove screws (71), eye bolts (48), nut (73).</p> <p><b>b - ONLY VALID FOR 6" ÷ 10"</b> Loosen the screws (71) and remove the washers (33).</p>
2	Remove the upper lid (4).
3	<p><b>a - ONLY VALID FOR 4" ÷ 8"</b> Remove the spring (45).</p> <p><b>b - ONLY VALID FOR 10"</b> Pull out the springs (44, 45).</p>
4	Take out the diaphragm unit (14, 15, 20, 30).
5	Unscrew and remove the feed connection (35).
6	Unscrew and remove the fitting (11).
7	<p><b>ONLY VALID FOR 10"</b> Unscrew and remove the fitting (90).</p>
8	<p>Remove the O-rings (41, 42) from the fitting (11) and replace them, lubricating them with synthetic grease.</p> <div style="border: 1px solid black; padding: 5px;"> <p><b>! NOTICE!</b> <b>Before inserting the replacement O-rings, clean the retaining slots with a cleaning solution.</b></p> </div>
9	Remove the membrane protection grille (17).
10	Undo and remove the screws (28).
11	Remove the grid (10).
12	<p>Remove the valve seat (13).</p> <div style="border: 1px solid black; padding: 5px;"> <p><b>! NOTICE!</b> <b>Place it on a shockproof surface to facilitate the operation and to protect it in the event of a fall.</b></p> </div>
13	<p>Remove the O-ring (40) from the seat (13) and replace it, lubricating it with synthetic grease.</p> <div style="border: 1px solid black; padding: 5px;"> <p><b>! NOTICE!</b> <b>Before inserting the replacement O-ring, clean the retaining slots with a cleaning solution.</b></p> </div>
14	Remove spacer ring (16).
15	Unscrew and remove the nut (68).
16	Remove the upper flange (58).
17	<p>Remove the O-ring (81) from the upper flange (58) and replace it, lubricating it with synthetic grease.</p> <div style="border: 1px solid black; padding: 5px;"> <p><b>! NOTICE!</b> <b>Before inserting the replacement O-ring, clean the retaining slots with a cleaning solution.</b></p> </div>
18	Remove the upper anti-oil gasket (88).
19	Remove the external basket (64).
20	Remove the plating (60).
21	Unscrew and remove the valve seat support (61).



*Silencer DB/851 4"- 10"*

Step	Action
22	Remove the O-ring (84) from the sleeve (63) and replace it, taking care to lubricate it with synthetic grease. <b>! NOTICE!</b> <b>Before inserting the replacement O-ring, clean the retaining slots with a cleaning solution.</b>
23	Remove the internal basket (65). <b>! NOTICE!</b> <b>With the help of tool ref. O, "Tab. 7.48" of "7.1 - List of equipment".</b>
24	Remove and replace the lower anti-oil gasket (88).
25	<b>a - ONLY VALID FOR 4" ÷ 8"</b> Undo and remove the screws (69) and the washers (70). <b>b - ONLY VALID FOR 10"</b> Undo and remove the screws (69).
26	Remove the lower flange (59) together with the tie rods (67).
27	Remove the O-ring (37) from the lower flange (59) and replace it, lubricating it with synthetic grease. <b>! NOTICE!</b> <b>Before inserting the replacement O-ring, clean the retaining slots with a cleaning solution.</b>
28	<b>ONLY VALID FOR 10"</b> Remove the O-ring (85) from the lower flange (59) and replace it, lubricating it with synthetic grease. <b>! NOTICE!</b> <b>Before inserting the replacement O-ring, clean the retaining slots with a cleaning solution.</b>
29	<b>! WARNING!</b> <b>Support the flange or any accessory to prevent it from falling</b>
30	Undo and remove the screws (25).
31	Remove the blind flange (5) or any built-in accessory (SB/82, HB/97 slam-shut valve or PM/819 monitor).
32	Remove the O-ring (37) from the blind flange (5) and replace it, lubricating it with synthetic grease. <b>! NOTICE!</b> <b>Before inserting the replacement O-ring, clean the retaining slots with a cleaning solution.</b>
33	<b>! WARNING!</b> <b>Support the sleeve (63) during the next steps to prevent it from falling.</b>
34	Undo and remove the screws (27), the shaft collar (6) and the conical seat (8).
35	Remove the sleeve (63) from the top downwards.
36	Remove and replace the O-ring (83) at the sleeve (63). <b>! NOTICE!</b> <b>Before inserting the replacement O-ring, clean the retaining slots with a cleaning solution.</b>

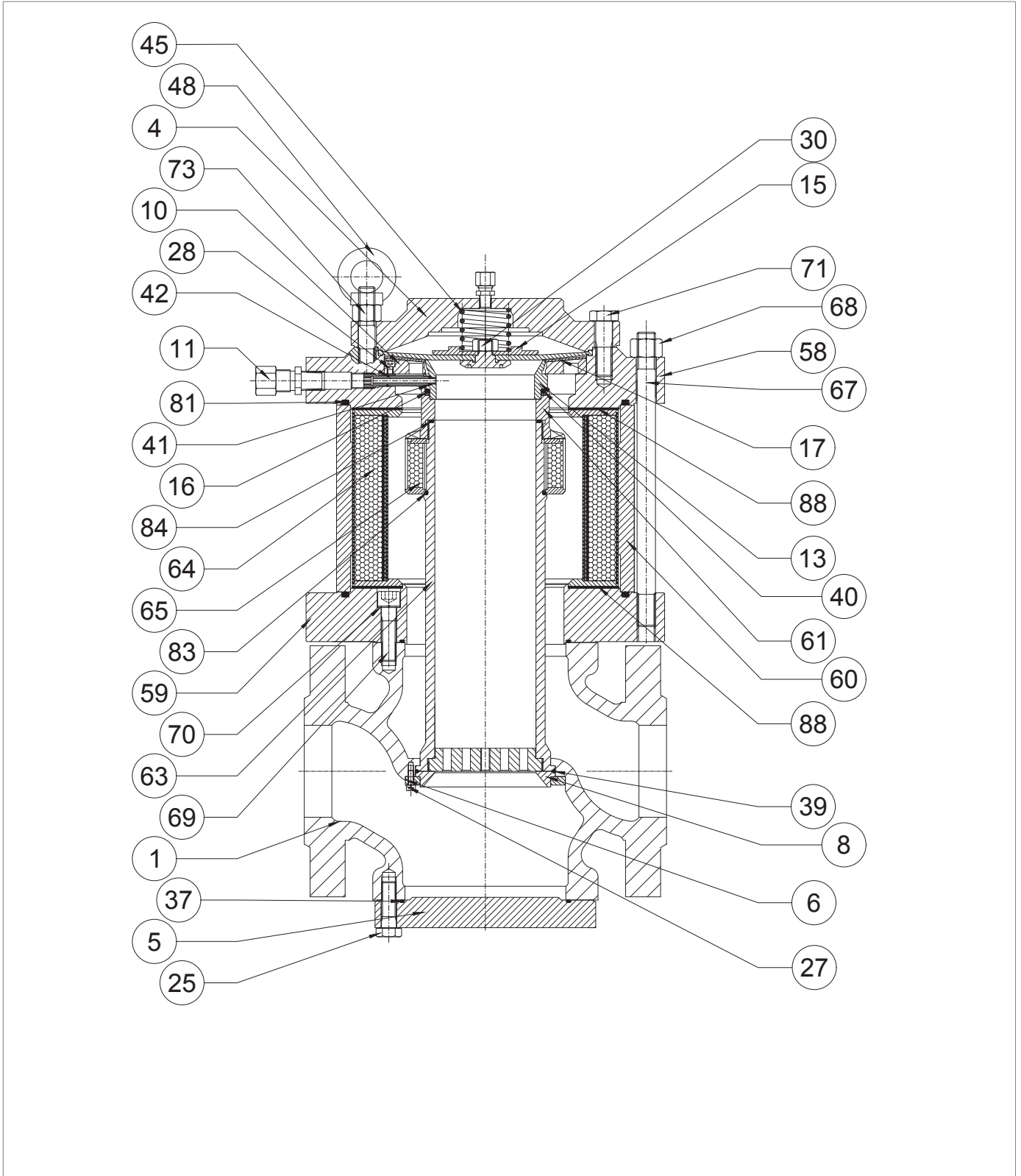

*Silencer DB/851 4"- 10"*

Step	Action
37	Remove the O-ring (39) from the conical seat (8) and replace it, lubricating it with synthetic grease. <b>! NOTICE!</b> <b>Before inserting the replacement O-ring, clean the retaining slots with a cleaning solution.</b>
38	Clean the upper and lower bearing surfaces of the body (1) and the flanges (2,5), the contact surfaces between the sleeve (63), conical seat (8) and the body.
39	<b>a - ONLY VALID FOR 4" ÷ 8"</b> Replace the sleeve (9) into the body from bottom upwards. <b>b - ONLY VALID FOR 10"</b> Replace the sleeve (9) into the body from bottom upwards. <b>! NOTICE!</b> and note hole orientating .
40	Replace the conical seat (8) together with the O-ring (39) and the shaft collar (6). <b>! NOTICE!</b> <b>As an alternative to the conical seat (8), a reinforced gasket may be present, based on the built-in accessory.</b>
41	Insert and fix the screws (27) according to the following tightening torques: <ul style="list-style-type: none"> <li>• 4" : "Tab. 9.85";</li> <li>• 6" : "Tab. 9.86";</li> <li>• 8" : "Tab. 9.87";</li> <li>• 10" : "Tab. 9.88".</li> </ul> <b>! NOTICE!</b> <b>Tighten the screws as shown in the diagram at "9.4.2.2 - Cross diagram for tightening screws".</b>
42	<b>! WARNING!</b> <b>Support the flange or any accessory to prevent it from falling</b>
43	Fit the blind flange (5) or any accessory.
44	Insert and fix the screws (25) according to the following tightening torques: <ul style="list-style-type: none"> <li>• 4" : "Tab. 9.85";</li> <li>• 6" : "Tab. 9.86";</li> <li>• 8" : "Tab. 9.87";</li> <li>• 10" : "Tab. 9.88".</li> </ul> <b>! NOTICE!</b> <b>Tighten the screws as shown in the diagram at "9.4.2.2 - Cross diagram for tightening screws".</b>
45	Fit the lower flange (59) together with the tie rods (67).
46	<b>! NOTICE!</b> <b>Replace the washers (70) before performing this operation.</b>
47	<b>ONLY VALID FOR 4" ÷ 8"</b> Insert the washers (70) and lubricate them with synthetic grease.

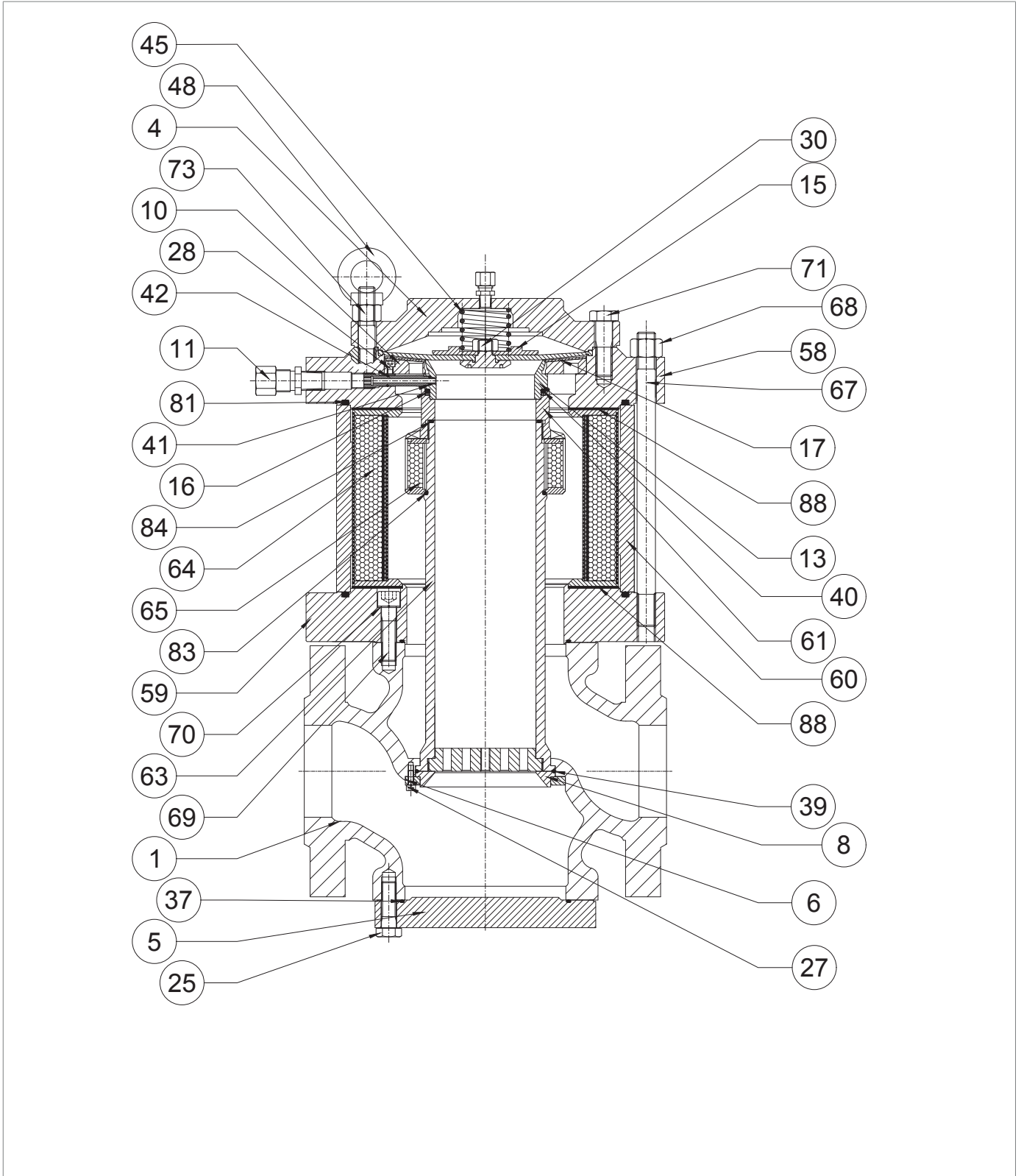

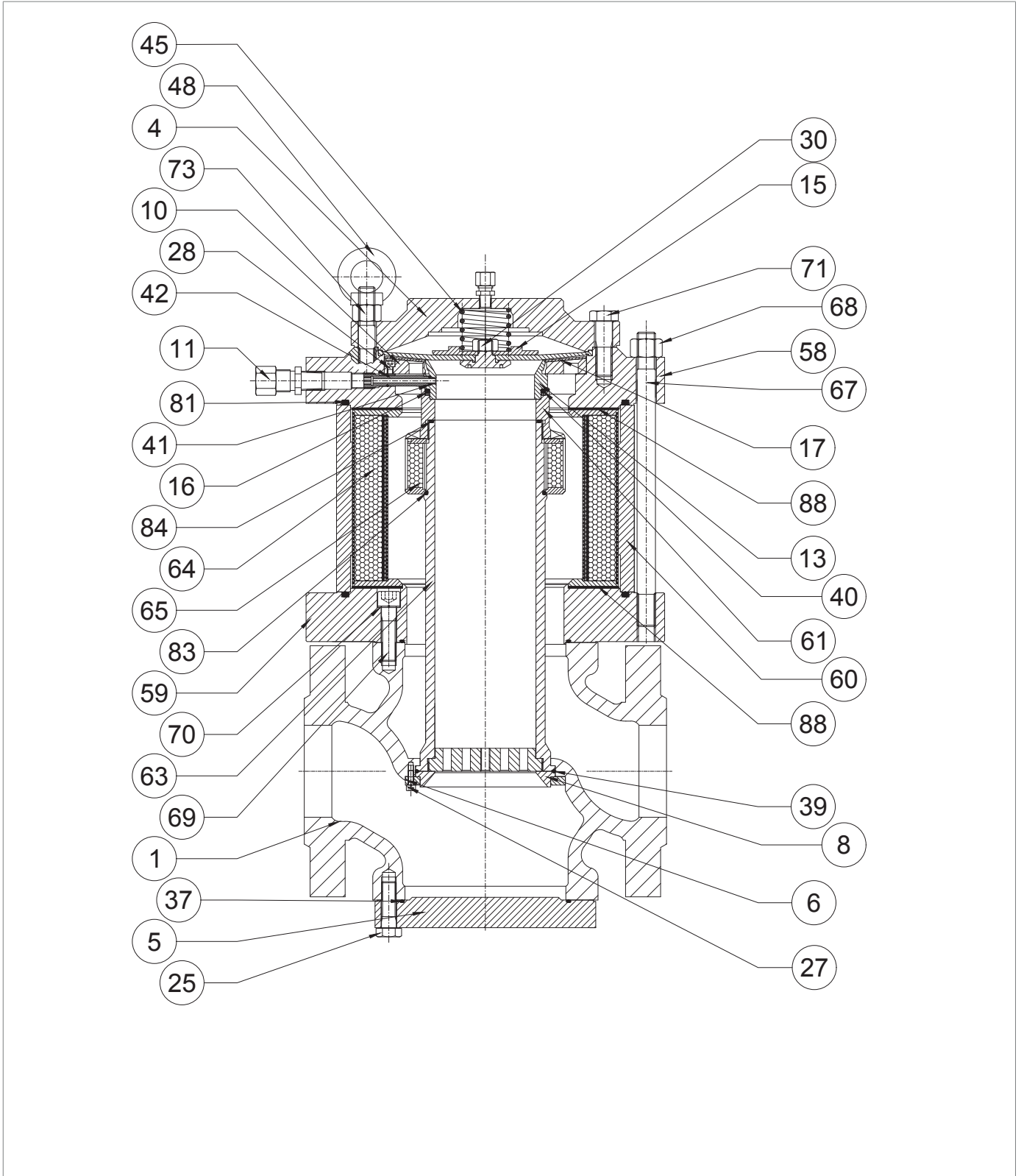

*Silencer DB/851 4" - 10"*

Step	Action
48	<p>Insert and fix the screws (69) according to the following tightening torques:</p> <ul style="list-style-type: none"> <li>4" : "Tab. 9.85";</li> <li>6" : "Tab. 9.86";</li> <li>8" : "Tab. 9.87";</li> <li>10" : "Tab. 9.88".</li> </ul> <div style="border: 1px solid black; padding: 5px;"> <p><b>! NOTICE!</b></p> <p><b>Tighten the screws as shown in the diagram at "9.4.2.2 - Cross diagram for tightening screws".</b></p> </div>
49	Fit the lower anti-oil gasket (88).
50	Fit the plating (60).
51	Fit the external basket (64).
52	<p>Fit the internal basket (65).</p> <div style="border: 1px solid black; padding: 5px;"> <p><b>! NOTICE!</b></p> <p><b>With the help of tool ref. O, "Tab. 7.48" of "7.1 - List of equipment".</b></p> </div>
53	Screw the valve seat bracket (61) to the sleeve.
54	Fit the new upper anti-oil gasket (88).
55	<p>Fit the upper flange (58).</p> <div style="border: 1px solid black; padding: 5px;"> <p><b>! NOTICE!</b></p> <p><b>Take care that the AR100's power connection faces upstream.</b></p> </div>
56	<p>Insert and fix the nuts (68) according to the following tightening torques:</p> <ul style="list-style-type: none"> <li>4" : "Tab. 9.85";</li> <li>6" : "Tab. 9.86";</li> <li>8" : "Tab. 9.87";</li> <li>10" : "Tab. 9.88".</li> </ul>
57	Place the ring (16) in the sleeve with the grooves pointing downwards.
58	<p><b>a - ONLY VALID FOR 4" ÷ 8"</b></p> <p>Insert the valve seat (13) into the sleeve (9) with the hole facing the hole in the intermediate flange (3).</p> <div style="border: 1px solid black; padding: 5px;"> <p><b>! NOTICE!</b></p> <p><b>Take care not to damage the O-ring (40).</b></p> </div> <p><b>b - ONLY VALID FOR 10"</b></p> <p>Place the valve seat (13) into the upper flange (58).</p>
59	<p><b>a - ONLY VALID FOR 4" ÷ 8"</b></p> <p>Insert and screw the fitting (11) into the hole.</p> <div style="border: 1px solid black; padding: 5px;"> <p><b>! NOTICE!</b></p> <ul style="list-style-type: none"> <li><b>Take care not to damage the O-rings (41, 42);</b></li> <li><b>Bring the O-ring (41) of the fitting (11) into contact with the valve seat bore (12), so that the seat is not displaced from its centring.</b></li> </ul> </div> <p><b>b - ONLY VALID FOR 10"</b></p> <p>Position and fix the fitting (90).</p>
60	Mount the feed connection (35).
61	Fit the grid (10).



*Silencer DB/851 4"- 10"*

Step	Action
62	Fit and fix the screws (28) according to the following tightening torques: <ul style="list-style-type: none"> <li>• 4" : "Tab. 9.85";</li> <li>• 6" : "Tab. 9.86";</li> <li>• 8" : "Tab. 9.87";</li> <li>• 10" : "Tab. 9.88".</li> </ul> <div style="border: 1px solid black; padding: 5px; margin-top: 10px;">  <b>NOTICE!</b>  <b>Tighten the screws as shown in the diagram at "9.4.2.2 - Cross diagram for tightening screws".</b> </div>
63	Position the membrane protection grid (17).
64	Put the diaphragm unit (14, 15, 20, 30) in place and lubricate the retaining slots with synthetic grease.
65	<b>a - ONLY VALID FOR 4" ÷ 8"</b> Fit the spring (45).  <b>b - ONLY VALID FOR 10"</b> Position the springs (44, 45).
66	Put in the upper cover (4).
67	Screw and fix the screws (71) according to the following tightening torques: <ul style="list-style-type: none"> <li>• 4" : "Tab. 9.85";</li> <li>• 6" : "Tab. 9.86";</li> <li>• 8" : "Tab. 9.87";</li> <li>• 10" : "Tab. 9.88".</li> </ul> <div style="border: 1px solid black; padding: 5px; margin-top: 10px;">  <b>NOTICE!</b>  <b>Tighten the screws as shown in the diagram at "9.4.2.2 - Cross diagram for tightening screws".</b> </div>
68	<b>ONLY VALID FOR 4"</b> Position and secure the nut (73) and the eyebolt (48).

Tab. 9.128

 **NOTICE!**

For the replacement of O-rings not mentioned in this procedure, refer to the maintenance sheet "APER-FLUX 851 4" – 8".

 **WARNING!**

Ensure that all parts have been fitted correctly.

**9.4.6 - PM/819 BUILT-IN MONITOR MAINTENANCE**

**9.4.6.1 - BUILT-IN MONITOR PM/819 1"÷ 2"**

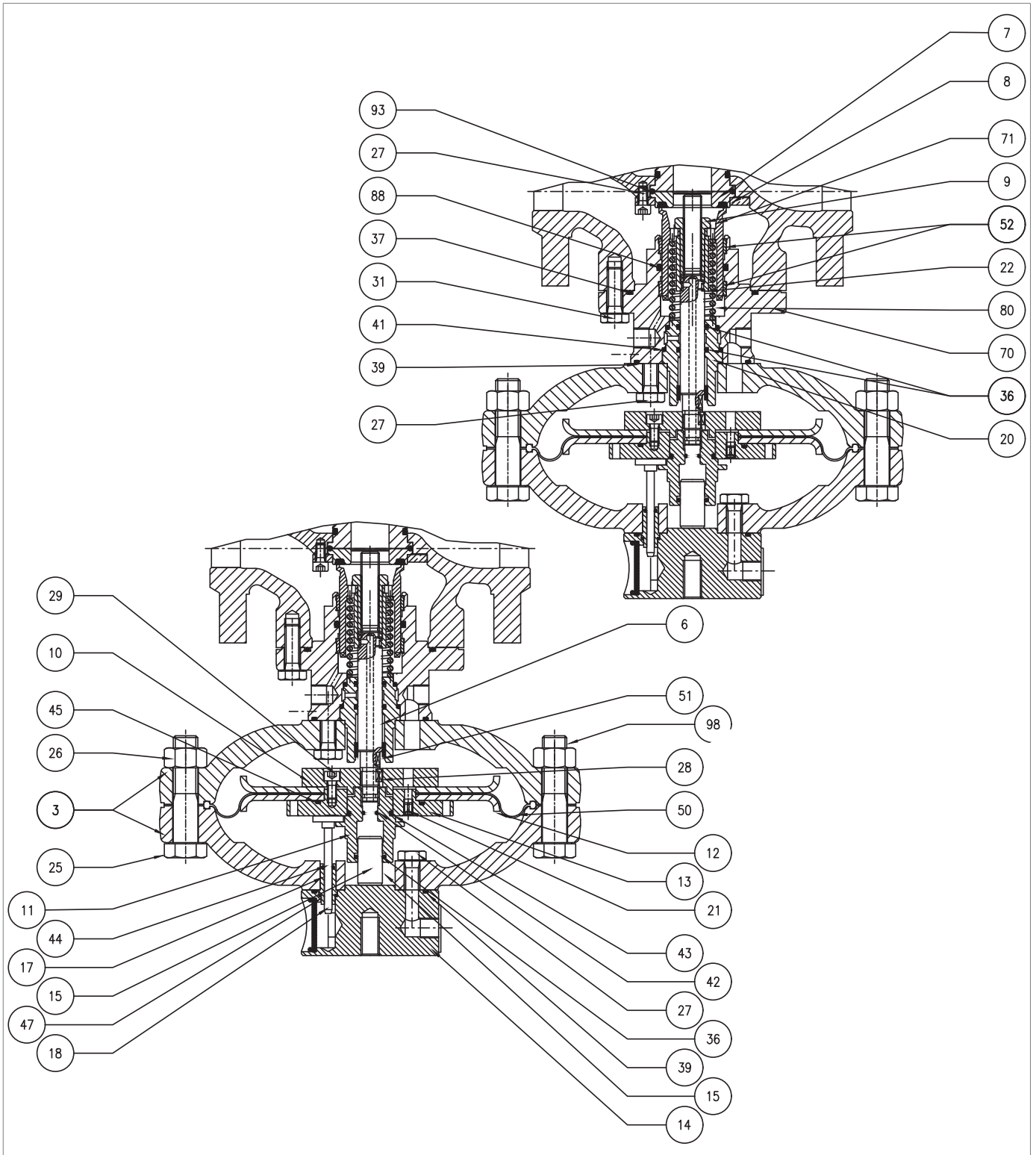
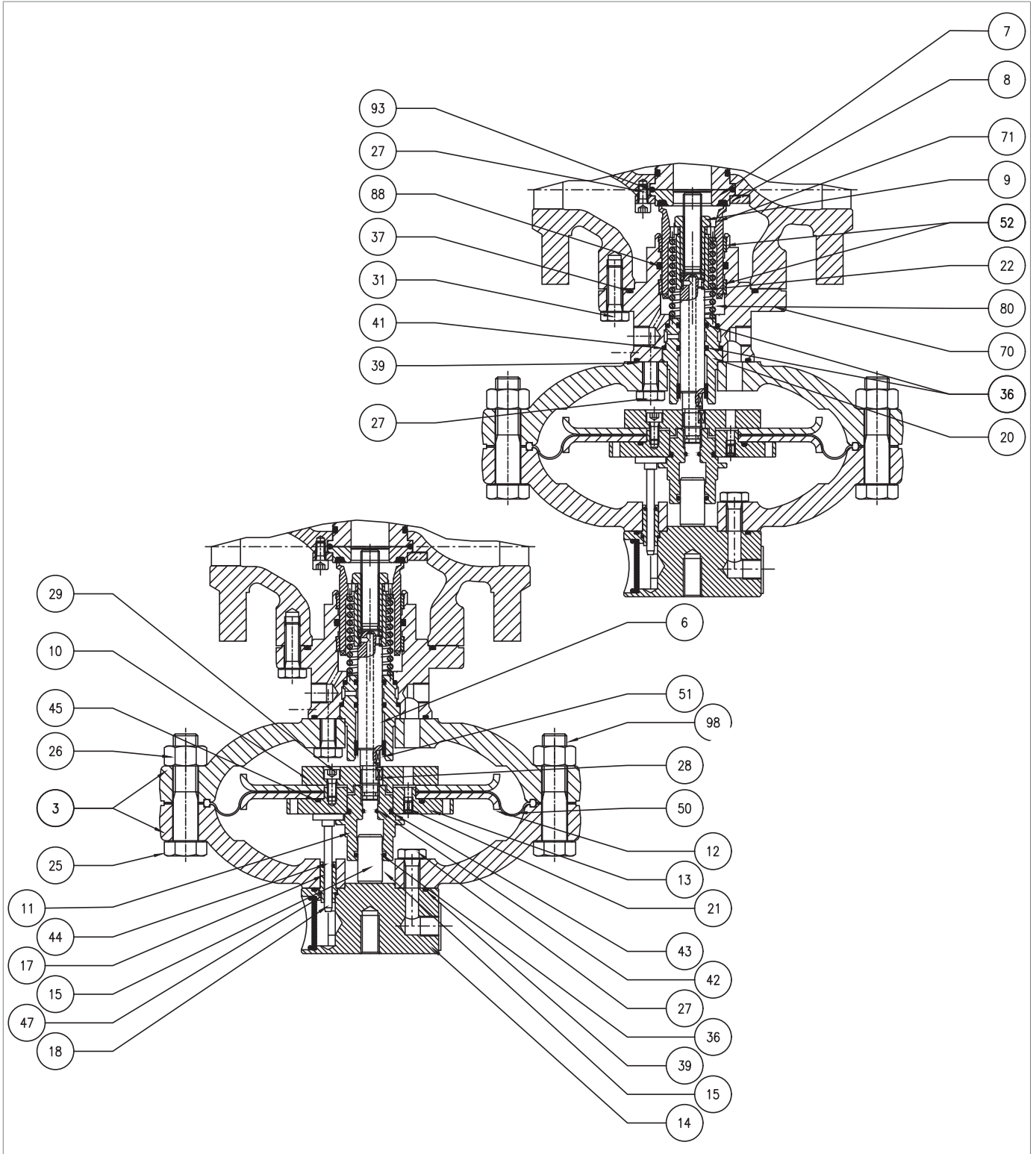

Fig. 9.62. Built-in monitor PM/819 1"÷ 2"

Step	Action
1	Disconnect the connection pipes between the regulator, the monitor and their pilot units, including the downstream pressure outlets.
2	Undo and remove the screws (31). <b>! NOTICE!</b> <b>Support the head assembly during this step to avoid falls.</b>
3	Remove the reduction unit and place it on its side, on an anti-shock surface. <b>! NOTICE!</b> <b>Take care not to damage the plug profile (71).</b>
4	Remove the O-ring (37) from the plug guide (70) and replace it, lubricating it with synthetic grease. <b>! NOTICE!</b> <b>Before inserting the replacement O-ring, clean the retaining slots with a cleaning solution.</b>
5	Undo and remove the screws (30), the shaft collar (8), the reinforced gasket (7) and the O-ring (39), preventing them from falling. <b>! NOTICE!</b> <b>Make sure that the sleeve does not fall (only for aperflux and app. with DB).</b>
6	Remove the O-ring (39) from the reinforced gasket (7) and replace it, lubricating it with synthetic grease. <b>! NOTICE!</b> <b>Before inserting the replacement O-ring, clean the retaining slots with a cleaning solution.</b>
7	Position the reinforced gasket (7) and the shaft collar (8).
8	Insert and fix the screws (30) according to the following tightening torque: <ul style="list-style-type: none"> <li>1" : "Tab. 9.86";</li> <li>2" : "Tab. 9.87".</li> </ul> <b>! NOTICE!</b> <b>Tighten the screws as shown in the diagram at "9.4.2.2 - Cross diagram for tightening screws".</b>
9	Unscrew the lock nut (9). <b>! NOTICE!</b> <b>Take care not to damage the plug profile (71).</b>
10	Remove the plug (71) and place it on an anti-shock surface.
11	Remove the spring (80) and the spacer (22).
12	Remove and replace the I/DWR rings (52) from the plug guide (70). <b>! NOTICE!</b> <b>Before inserting the replacement I/DWR rings, clean the retaining slots with a cleaning solution.</b>
13	Remove the O-ring (88) from the plug (70) and replace it, lubricating it with synthetic grease. <b>! NOTICE!</b> <b>Before inserting the replacement O-ring, clean the retaining slots with a cleaning solution.</b>
14	Clean the plug (71) and the plug guide (70) lubricating with silicone grease.



*Built-in monitor PM/819 1"÷ 2"*

Step	Action
15	Unscrew and remove the nuts (26) together with the screws (25, 98).
16	Remove the upper lid (3).
17	Remove the indicator rod (18) from the rod guide (17).
18	Undo and remove the screws of the upper section (27).
19	Separate the upper cover (3) from the eyebolt flange (14).
20	Take out the rod guide (17).
21	Remove the O-rings (39, 47) from the eyebolt flange (14) and replace them, lubricating them with synthetic grease. <b>NOTICE!</b> <b>Before inserting the replacement O-ring, clean the retaining slots with a cleaning solution.</b>
22	Remove the O-ring (44) from the rod guide (17) and replace it, lubricating it with synthetic grease. <b>NOTICE!</b> <b>Before inserting the replacement O-ring, clean the retaining slots with a cleaning solution.</b>
23	Place the rod guide (17) in the eyebolt flange (14).
24	Assemble the eyebolt flange (14) with the upper lid (3).
25	Insert and fix the screws of the upper section (27) according to the following tightening torque: <ul style="list-style-type: none"> <li>1" : "Tab. 9.89";</li> <li>2" : "Tab. 9.90".</li> </ul> <b>NOTICE!</b> <b>Tighten the screws as shown in the diagram at "9.4.2.2 - Cross diagram for tightening screws".</b>
26	Insert the indicator rod (18) into the rod guide (17).
27	Unscrew and remove the piston guide (11). <b>NOTICE!</b> <b>In this step, keep the diaphragm unit still, fitting the compass wrench into the holes in the upper diaphragm support (13).</b>
28	Remove the balancing piston (15) from the piston guide (11).
29	Remove the O-rings (36, 43) from the eyebolt flange (11) and replace them, lubricating them with synthetic grease. <b>NOTICE!</b> <b>Before inserting the replacement O-rings, clean the retaining slots with a cleaning solution.</b>
30	Place the balancing piston (15) in the piston guide (11).
31	Take out the diaphragm unit.
32	Unscrew and remove the screws (29) from the lower diaphragm support (10).
33	Remove the diaphragm support (10) and the lower diaphragm protection disc (12).
34	Remove the diaphragm (50).
35	Remove the upper diaphragm support (13) from the lower diaphragm protection disc (12).
36	Remove and replace the O-ring (45) from the upper diaphragm support (13), lubricating it with synthetic grease. <b>NOTICE!</b> <b>Before inserting the replacement O-ring, clean the retaining slots with a cleaning solution.</b>

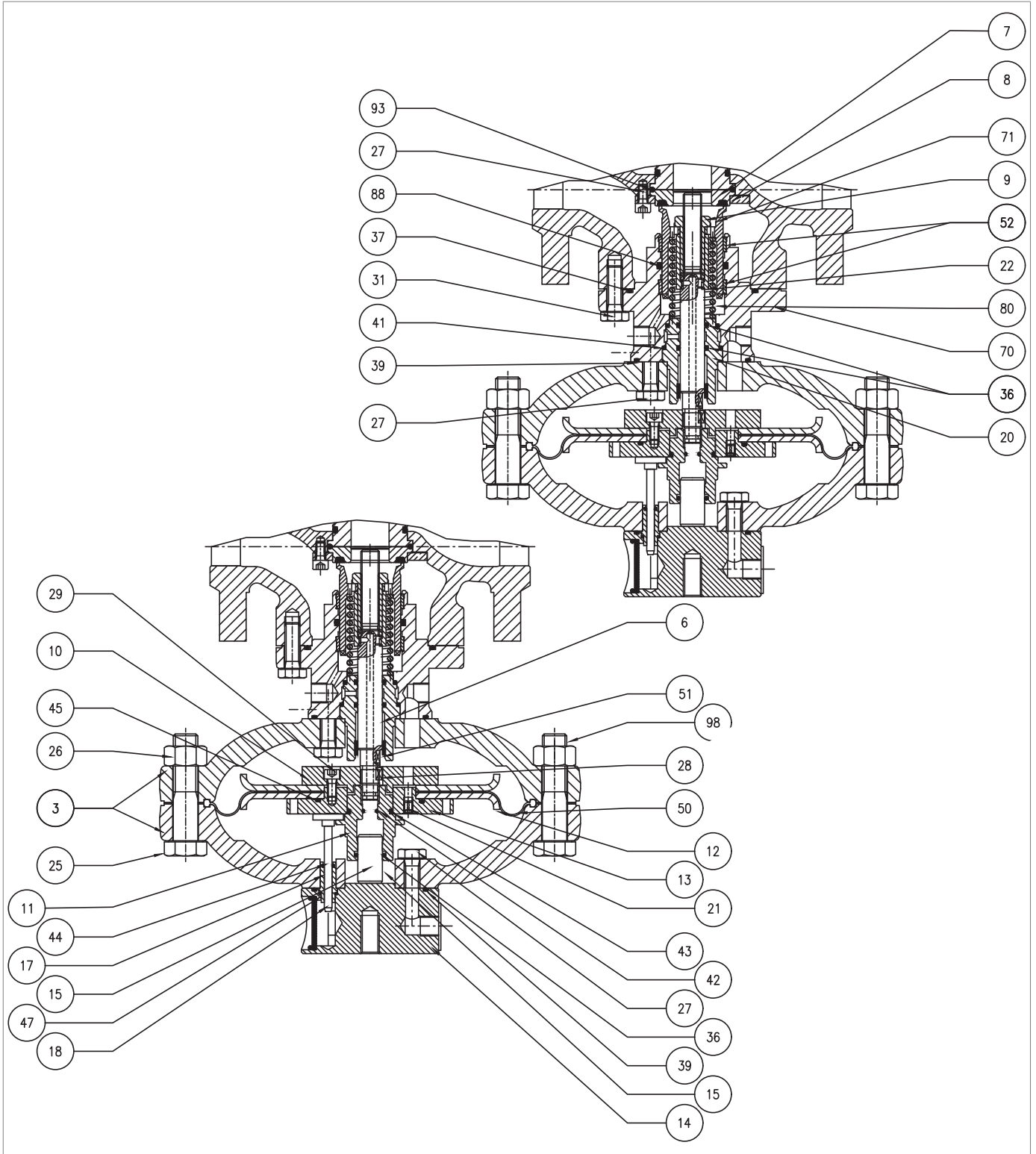

Built-in monitor PM/819 1"÷ 2"

Step	Action
37	<p>Put the upper diaphragm support (13) back in place into the upper diaphragm protection disc (12).</p> <p><b>! NOTICE!</b></p> <p><b>Check that the hole on the nozzle (21) is free from dirt or foreign bodies.</b></p>
38	<p>Fit the new diaphragm (50).</p> <p><b>! NOTICE!</b></p> <p><b>Fit the diaphragm so that its convulsion is oriented towards the loading chamber.</b></p>
39	<p>Put the diaphragm protection disc (12) and the lower diaphragm support (10) in place.</p> <p><b>! NOTICE!</b></p> <p><b>Check that the nozzle hole on the upper diaphragm support (13) is aligned with the hole on the lower diaphragm support (10).</b></p>
40	<p>Apply thread locking glue to insert and fix the screws (29) according to the following tightening torque:</p> <ul style="list-style-type: none"> <li>1" : "Tab. 9.89";</li> <li>2" : "Tab. 9.90".</li> </ul> <p><b>! NOTICE!</b></p> <p><b>Tighten the screws as shown in the diagram at "9.4.2.2 - Cross diagram for tightening screws".</b></p>
41	Undo and remove the screws of the lower section (27).
42	Remove the lower cover (3).
43	<p>Remove the O-ring (39) from the plug guide (70) and replace it, lubricating it with synthetic grease.</p> <p><b>! NOTICE!</b></p> <p><b>Before inserting the replacement O-ring, clean the retaining slots with a cleaning solution.</b></p>
44	Remove the stem guide (20), the stem (6) and the key (28).
45	<p>Remove and replace the I/DWR rings (51) from the stem guide (20).</p> <p><b>! NOTICE!</b></p> <p><b>Before inserting the replacement O-ring, clean the retaining slots with a cleaning solution.</b></p>
46	<p>Remove the O-rings (36) from the stem guide (20) and replace them, lubricating them with synthetic grease.</p> <p><b>! NOTICE!</b></p> <p><b>Before inserting the replacement O-ring, clean the retaining slots with a cleaning solution.</b></p>
47	<p>Remove the O-rings (40, 41) from the stem guide (20) and replace them, lubricating them with synthetic grease.</p> <p><b>! NOTICE!</b></p> <p><b>Before inserting the replacement O-rings, clean the retaining slots with a cleaning solution.</b></p>
48	<p>Remove the O-ring (42) from the stem (6) and replace it, lubricating it with synthetic grease.</p> <p><b>! NOTICE!</b></p> <p><b>Before inserting the replacement O-ring, clean the retaining slots with a cleaning solution.</b></p>

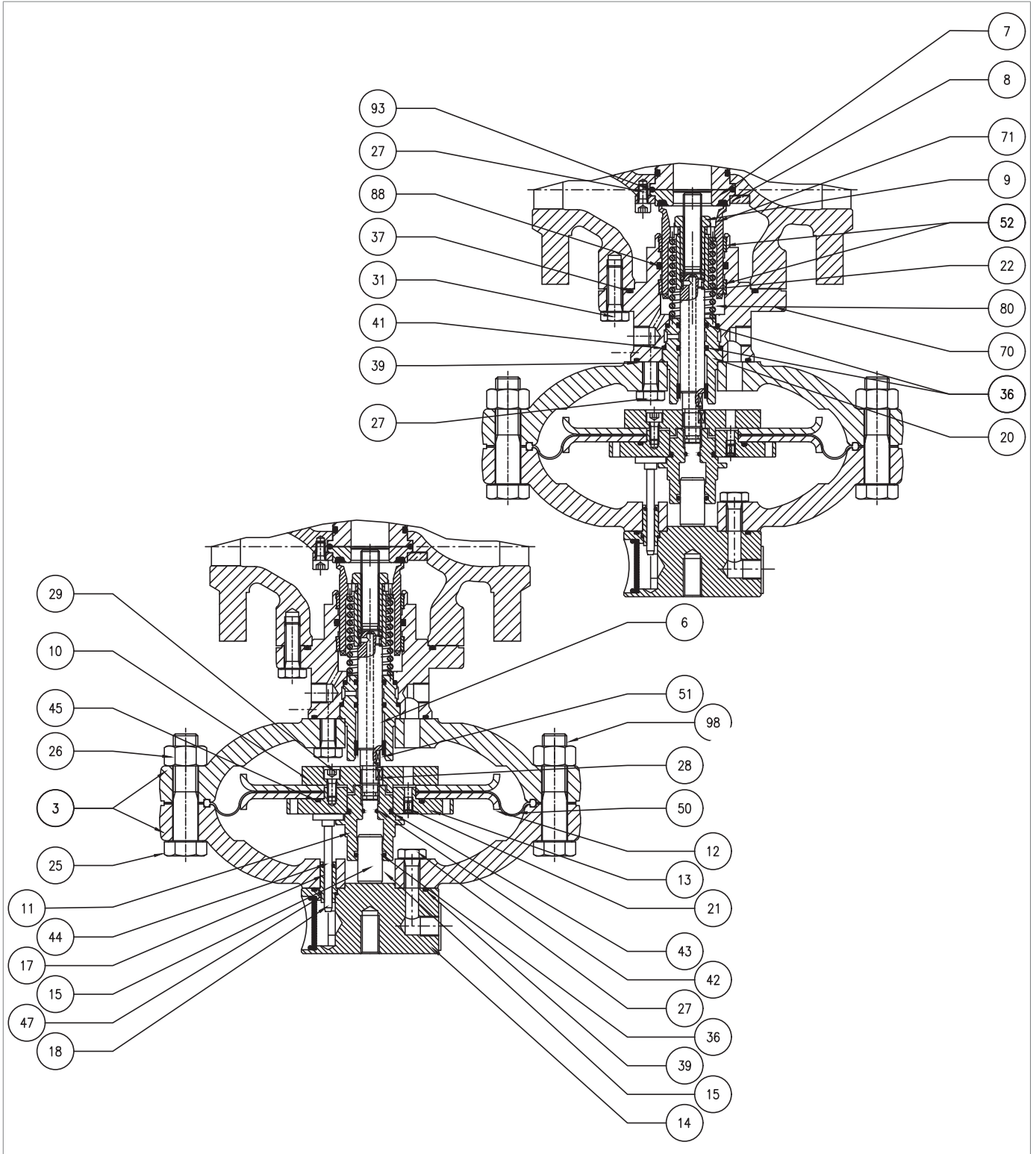

*Built-in monitor PM/819 1"÷ 2"*

Step	Action
49	<p>Remove the stem guide (20), the stem (6) and the key (28).</p> <div style="border: 1px solid blue; padding: 5px;"> <p><b>! NOTICE!</b></p> <p><b>Lubricate the stem surface with silicone grease; make sure that the key (28) is in the correct position in the stem (6).</b></p> </div>
50	<p>Put the lower lid (3) in place and fix it on the plug guide (70).</p> <div style="border: 1px solid blue; padding: 5px;"> <p><b>! NOTICE!</b></p> <p><b>Match the hole for the passage of the loading pressure to the similar one on the plug guide.</b></p> </div>
51	<p>Insert and fix the screws of the lower section (27) according to the following tightening torque:</p> <ul style="list-style-type: none"> <li>• 1" : "Tab. 9.89";</li> <li>• 2" : "Tab. 9.90".</li> </ul> <div style="border: 1px solid blue; padding: 5px;"> <p><b>! NOTICE!</b></p> <p><b>Tighten the screws as shown in the diagram at "9.4.2.2 - Cross diagram for tightening screws".</b></p> </div>
52	Put the diaphragm unit in place.
53	<p>Insert and fix the piston guide (11) according to the following tightening torques:</p> <ul style="list-style-type: none"> <li>• 1" : "Tab. 9.89";</li> <li>• 2" : "Tab. 9.90".</li> </ul> <div style="border: 1px solid blue; padding: 5px;"> <p><b>! NOTICE!</b></p> <p><b>In this step, keep the diaphragm unit still, fitting the compass wrench into the holes in the upper diaphragm support (13).</b></p> </div>
54	<p>Put the upper lid (3) in place, taking care to fit the indicator rod (18) into the gap between the upper diaphragm support (13) and the piston guide (11).</p> <div style="border: 1px solid blue; padding: 5px;"> <p><b>! NOTICE!</b></p> <ul style="list-style-type: none"> <li>• <b>The indicator rod (18) must not obstruct the hole on the upper diaphragm support (13);</b></li> <li>• <b>The flange stroke indicator is perpendicular to the gas flow and is visible.</b></li> </ul> </div>
55	Place the pilot support screw (98).
56	Fix the nut (26).
57	<p>Insert and fix the screws (25) with the nuts (26) according to the following tightening torques:</p> <ul style="list-style-type: none"> <li>• 1" : "Tab. 9.89";</li> <li>• 2" : "Tab. 9.90".</li> </ul>
58	<p>Put the spacer (22) and the spring (80) in place.</p> <div style="border: 1px solid blue; padding: 5px;"> <p><b>! NOTICE!</b></p> <p><b>Fit the spacer (22) so that the stop with the narrower hole rests on the surface of the stem (6).</b></p> </div>
59	Insert the plug (71).
60	<p>Insert the locking nut (9) according to the following tightening torques:</p> <ul style="list-style-type: none"> <li>• 1" : "Tab. 9.89";</li> <li>• 2" : "Tab. 9.90".</li> </ul> <div style="border: 1px solid blue; padding: 5px;"> <p><b>! NOTICE!</b></p> <p><b>Before fixing the lock nut (9), check that the spring (80) is well seated in the appropriate centring stop on the plug guide (70).</b></p> </div>

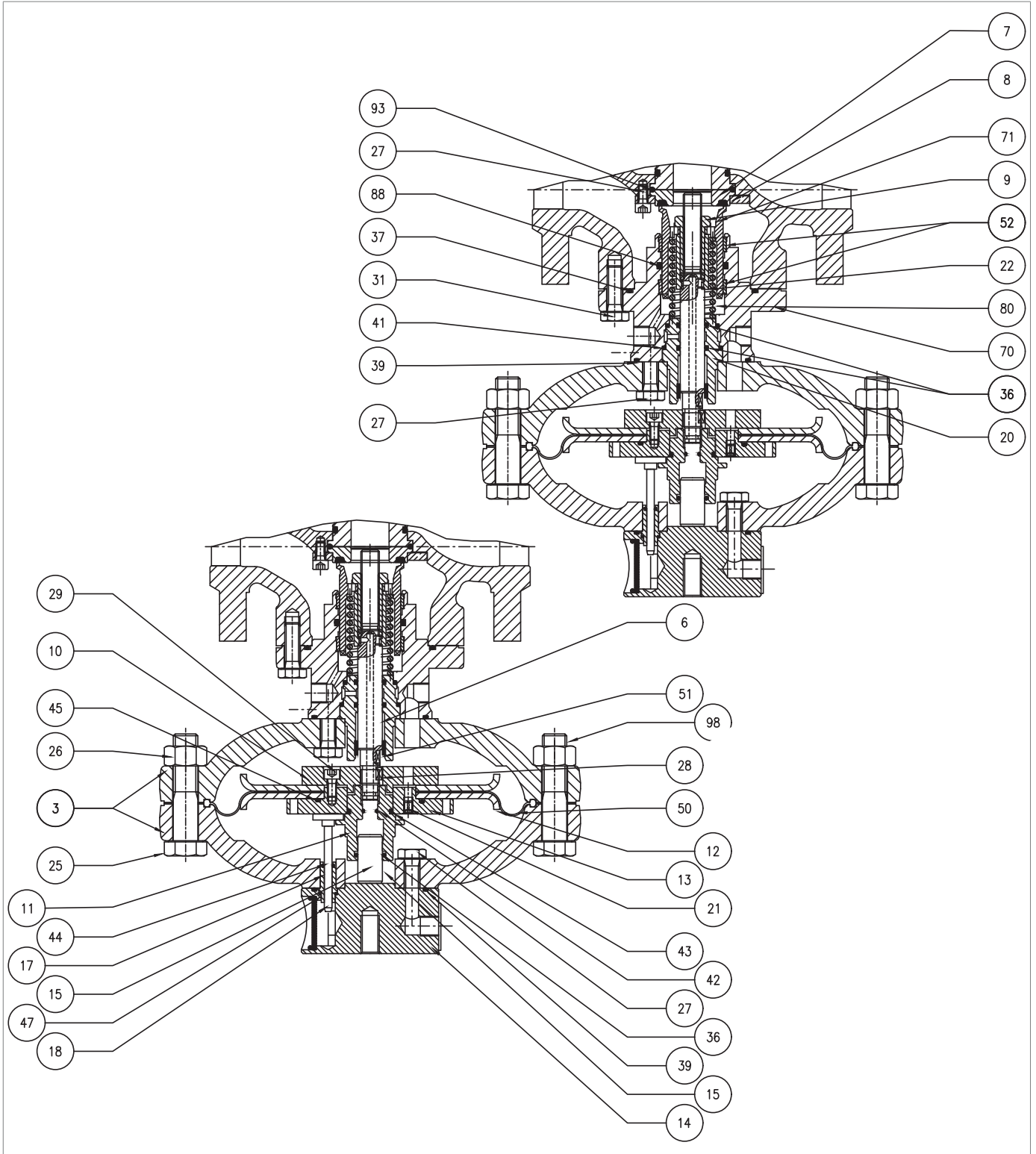

*Built-in monitor PM/819 1"÷ 2"*

Step	Action
61	<p>Position the reduction unit, supporting it carefully.</p> <div style="border: 1px solid black; padding: 5px;"> <p><b>! NOTICE!</b></p> <p><b>Lubricate the stem surface with silicone grease; make sure that the key (28) is in the correct position in the stem (6).</b></p> </div>
62	<p>Fit and fix the screws (31) according to the following tightening torques:</p> <ul style="list-style-type: none"> <li>• 1" : "Tab. 9.89";</li> <li>• 2" : "Tab. 9.90".</li> </ul> <div style="border: 1px solid black; padding: 5px;"> <p><b>! NOTICE!</b></p> <p><b>Tighten the screws as shown in the diagram at "9.4.2.2 - Cross diagram for tightening screws".</b></p> </div>
63	<p>Connect the connection pipes between the regulator, the monitor and their pilot units, including the downstream pressure outlets.</p>

Tab. 9.129

**! WARNING!**

**Ensure that all parts have been fitted correctly.**

**9.4.6.2 - BUILT-IN MONITOR PM/819 3"÷ 4"**

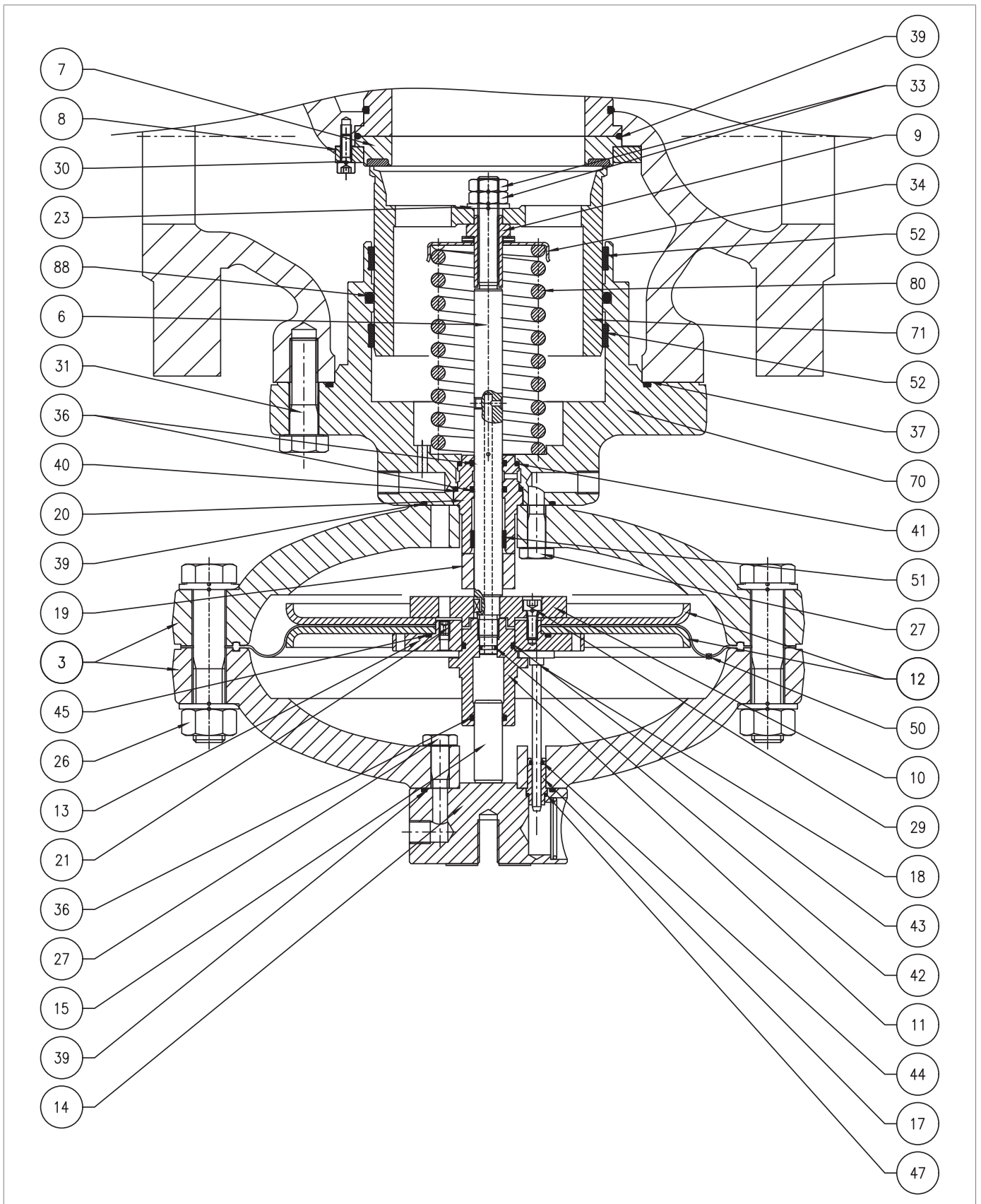
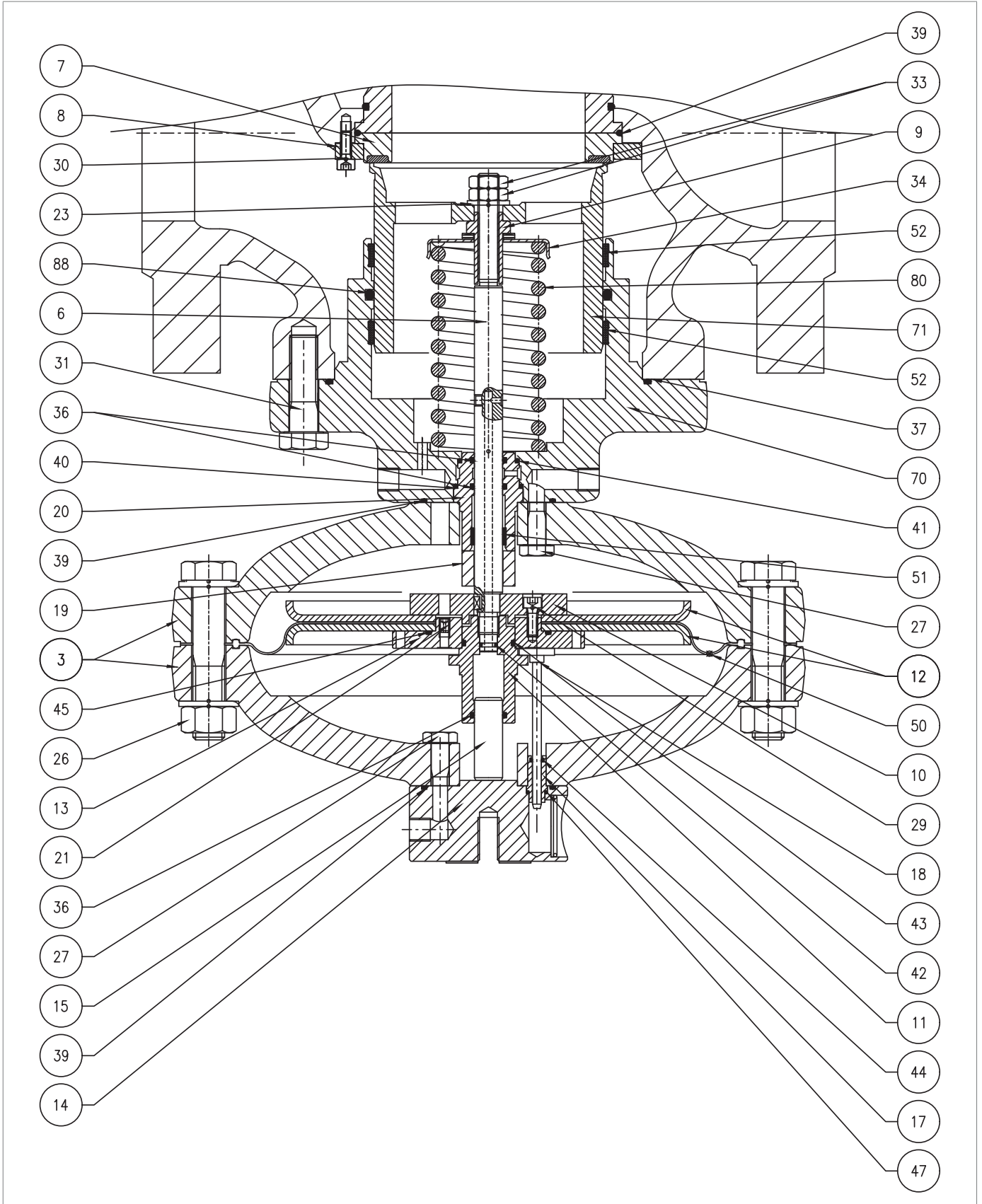

Fig. 9.63. Built-in monitor PM/819 3"÷ 4"

Step	Action
1	Disconnect the connection pipes between the regulator, the monitor and their pilot units, including the downstream pressure outlets.
2	Undo and remove the screws (31). <b>NOTICE!</b> <b>Support the head assembly during this step to avoid falls.</b>
3	Remove the reduction unit and place it on its side, on an anti-shock surface. <b>NOTICE!</b> <b>Take care not to damage the plug profile (71).</b>
4	Remove the O-ring (37) from the plug guide (70) and replace it, lubricating it with synthetic grease. <b>NOTICE!</b> <b>Before inserting the replacement O-ring, clean the retaining slots with a cleaning solution.</b>
5	Unscrew and remove the screws (30), the shaft collar (8) and the reinforced gasket (7), preventing them from falling. <b>NOTICE!</b> <b>Carefully prevent the sleeve from falling.</b>
6	Remove the O-ring (39) from the reinforced gasket (7) and replace it, lubricating it with synthetic grease. <b>NOTICE!</b> <b>Before inserting the replacement O-ring, clean the retaining slots with a cleaning solution.</b>
7	Position the reinforced gasket (7) and the shaft collar (8).
8	Insert and fix the screws (30) according to the following tightening torques: <ul style="list-style-type: none"> <li>• 3" : "Tab. 9.91";</li> <li>• 4" : "Tab. 9.92".</li> </ul> <b>NOTICE!</b> <b>Tighten the screws as shown in the diagram at "9.4.2.2 - Cross diagram for tightening screws".</b>
9	Unscrew and remove the nuts (33) together with the washer (23).
10	Remove the plug (71) and place it on an anti-shock surface.
11	Unscrew the lock nut (9).
12	Remove the spring (80) and the spring support (34).
13	Remove and replace the I/DWR rings (52) from the plug guide (70). <b>NOTICE!</b> <b>Before inserting the replacement I/DWR rings, clean the retaining slots with a cleaning solution.</b>
14	Remove the O-ring (88) from the plug (70) and replace it, lubricating it with synthetic grease. <b>NOTICE!</b> <b>Before inserting the replacement O-ring, clean the retaining slots with a cleaning solution.</b>
15	Clean the plug (70) and the plug guide (71), lubricating with silicone grease.
16	Unscrew and remove the nuts (26) together with the screws (25, 98).
17	Remove the upper lid (3).



*Built-in monitor PM/819 3"÷ 4"*

Step	Action
18	Remove the indicator rod (18) from the rod guide (17).
19	Undo and remove the upper screws (27).
20	Separate the upper cover (3) from the eyebolt flange (14).
21	Take out the rod guide (17).
22	Remove the O-rings (39, 47) from the eyebolt flange (14) and replace them, lubricating them with synthetic grease. <b>NOTICE!</b> <b>Before inserting the replacement O-rings, clean the retaining slots with a cleaning solution.</b>
23	Remove the O-ring (44) from the rod guide (17) and replace it, lubricating it with synthetic grease. <b>NOTICE!</b> <b>Before inserting the replacement O-ring, clean the retaining slots with a cleaning solution.</b>
24	Place the rod guide (17) in the eyebolt flange (14).
25	Assemble the eyebolt flange (14) with the upper lid (3).
26	Insert and fix the upper screws (27) according to the following tightening torques: <ul style="list-style-type: none"> <li>3" : "Tab. 9.91";</li> <li>4" : "Tab. 9.92".</li> </ul> <b>NOTICE!</b> <b>Tighten the screws as shown in the diagram at "9.4.2.2 - Cross diagram for tightening screws".</b>
27	Insert the indicator rod (18) into the rod guide (17).
28	Unscrew and remove the piston guide (11). <b>NOTICE!</b> <b>In this step, keep the diaphragm unit still, fitting the compass wrench into the holes in the upper diaphragm support (13).</b>
29	Remove the balancing piston (15) from the piston guide (11).
30	Remove the O-rings (36, 43) from the eyebolt flange (11) and replace them, lubricating them with synthetic grease. <b>NOTICE!</b> <b>Before inserting the replacement O-rings, clean the retaining slots with a cleaning solution.</b>
31	Place the balancing piston (15) in the piston guide (11).
32	Take out the diaphragm unit.
33	Undo and remove the screws (29) from the lower diaphragm support (10).
34	Remove the diaphragm support (10) and the lower diaphragm protection disc (12).
35	Remove the diaphragm (50).
36	Remove the upper diaphragm support (13) from the upper diaphragm protection disc (12).
37	Remove and replace the O-ring (45) from the upper diaphragm support (13), lubricating it with synthetic grease. <b>NOTICE!</b> <b>Before inserting the replacement O-ring, clean the retaining slots with a cleaning solution.</b>

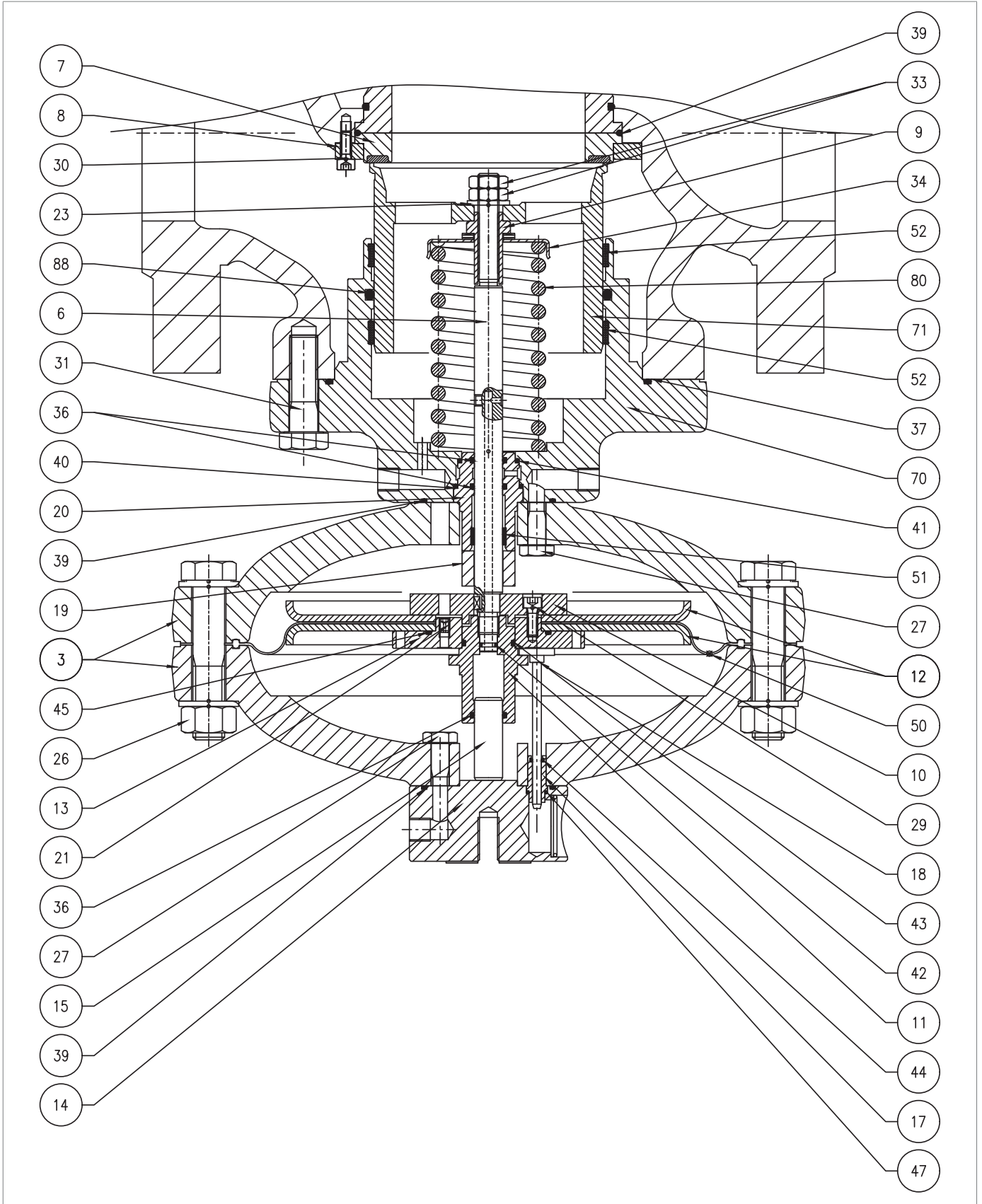

*Built-in monitor PM/819 3"÷ 4"*

Step	Action
38	<p>Put the upper diaphragm support (13) back in place into the upper diaphragm protection disc (12).</p> <p><b>! NOTICE!</b></p> <p><b>Check that the hole on the nozzle (21) is free from dirt or foreign bodies.</b></p>
39	<p>Fit the new diaphragm (50).</p> <p><b>! NOTICE!</b></p> <p><b>Fit the diaphragm so that its convulsion is oriented towards the loading chamber.</b></p>
40	<p>Put the lower diaphragm protection disc (12) and the lower diaphragm support (10) in place.</p> <p><b>! NOTICE!</b></p> <p><b>Check that the nozzle hole on the upper diaphragm support (13) is aligned with the hole on the lower diaphragm support (10).</b></p>
41	<p>Apply thread locking glue to insert and fix the screws (29) according to the following tightening torques:</p> <ul style="list-style-type: none"> <li>• 3" : "Tab. 9.91";</li> <li>• 4" : "Tab. 9.92".</li> </ul> <p><b>! NOTICE!</b></p> <p><b>Tighten the screws as shown in the diagram at "9.4.2.2 - Cross diagram for tightening screws".</b></p>
42	Undo and remove the lower screws (27).
43	Remove the lower cover (3).
44	<p>Remove the O-ring (39) from the plug guide (70) and replace it, lubricating it with synthetic grease.</p> <p><b>! NOTICE!</b></p> <p><b>Before inserting the replacement O-ring, clean the retaining slots with a cleaning solution.</b></p>
45	Remove the spacer (19), the stem guide (20) the stem (6) and the key (28).
46	<p>Remove and replace the I/DWR rings (51) from the stem guide (20).</p> <p><b>! NOTICE!</b></p> <p><b>Before inserting the replacement I/DWR, clean the retaining slots with a cleaning solution.</b></p>
47	<p>Remove the O-rings (36) from the stem guide (20) and replace them, lubricating them with synthetic grease.</p> <p><b>! NOTICE!</b></p> <p><b>Before inserting the replacement O-rings, clean the retaining slots with a cleaning solution.</b></p>
48	<p>Remove the O-rings (40, 41) from the stem guide (20) and replace them, lubricating them with synthetic grease.</p> <p><b>! NOTICE!</b></p> <p><b>Before inserting the replacement O-rings, clean the retaining slots with a cleaning solution.</b></p>
49	<p>Remove the O-ring (42) from the stem (6) and replace it, lubricating it with synthetic grease.</p> <p><b>! NOTICE!</b></p> <p><b>Before inserting the replacement O-ring, clean the retaining slots with a cleaning solution.</b></p>

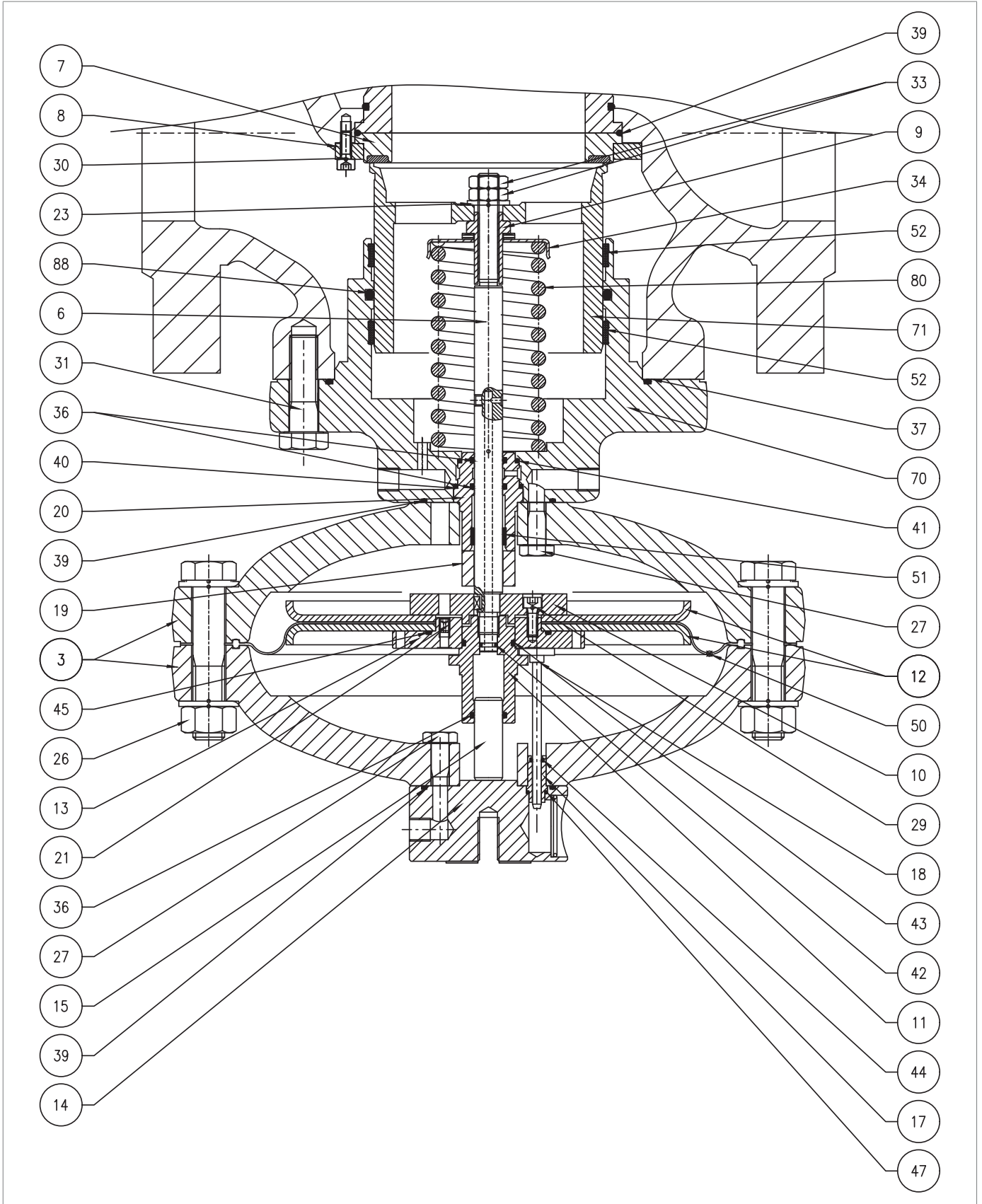

*Built-in monitor PM/819 3"÷ 4"*

Step	Action
50	<p>Remove the stem guide (20), the stem (6) the spacer (19) and the key (28).</p> <div style="border: 1px solid black; padding: 5px;"> <p><b>! NOTICE!</b></p> <ul style="list-style-type: none"> <li>• <b>Lubricate the rod surface with silicone grease;</b></li> <li>• <b>Make sure that the key (28) is in the correct position in the stem (6).</b></li> </ul> </div>
51	<p>Put the lower lid (3) in place and fix it on the plug guide (70).</p> <div style="border: 1px solid black; padding: 5px;"> <p><b>! NOTICE!</b></p> <p><b>The hole for the passage of the loading pressure must match the similar one on the plug guide.</b></p> </div>
52	<p>Insert and fix the lower screws (27) according to the following tightening torques:</p> <ul style="list-style-type: none"> <li>• 3" : "Tab. 9.91";</li> <li>• 4" : "Tab. 9.92".</li> </ul> <div style="border: 1px solid black; padding: 5px;"> <p><b>! NOTICE!</b></p> <p><b>Tighten the screws as shown in the diagram at "9.4.2.2 - Cross diagram for tightening screws".</b></p> </div>
53	<p>Put the diaphragm unit in place.</p> <div style="border: 1px solid black; padding: 5px;"> <p><b>! NOTICE!</b></p> <p><b>Before inserting the diaphragm unit, clean the retaining slots of the lids (3) with a cleaning solution.</b></p> </div>
54	<p>Insert and fix the piston guide (11) according to the following tightening torques:</p> <ul style="list-style-type: none"> <li>• 3" : "Tab. 9.91";</li> <li>• 4" : "Tab. 9.92".</li> </ul> <div style="border: 1px solid black; padding: 5px;"> <p><b>! NOTICE!</b></p> <p><b>In this step, keep the diaphragm unit still, fitting the compass wrench into the holes in the upper diaphragm support (13).</b></p> </div>
55	<p>Put the upper lid (3) in place, taking care to fit the indicator rod (18) into the gap between the upper diaphragm support (13) and the piston guide (11).</p> <div style="border: 1px solid black; padding: 5px;"> <p><b>! NOTICE!</b></p> <ul style="list-style-type: none"> <li>• <b>The indicator rod (18) must not obstruct the hole on the upper diaphragm support (13);</b></li> <li>• <b>The eyebolt flange stroke indicator (14) must be perpendicular to the gas flow and visible.</b></li> </ul> </div>
56	<p>Insert and fix the screws (25, 98) with the nuts (26) according to the following tightening torques:</p> <ul style="list-style-type: none"> <li>• 3" : "Tab. 9.91";</li> <li>• 4" : "Tab. 9.92".</li> </ul> <div style="border: 1px solid black; padding: 5px;"> <p><b>! NOTICE!</b></p> <p><b>Tighten the screws as shown in the diagram at "9.4.2.2 - Cross diagram for tightening screws".</b></p> </div>
57	<p>Put the spring (80) and spring support back (34) back in place.</p>
58	<p>Insert the lock nut (9) together with the radial bearing (30) according to the tightening torques:</p> <ul style="list-style-type: none"> <li>• 3" : "Tab. 9.91";</li> <li>• 4" : "Tab. 9.92".</li> </ul> <div style="border: 1px solid black; padding: 5px;"> <p><b>! NOTICE!</b></p> <p><b>Before fixing the lock nut (9), check that the spring (80) is well seated in the appropriate centring stop on the plug guide (70).</b></p> </div>
59	<p>Put the plug (71) in place lubricating the surface with silicone grease.</p>

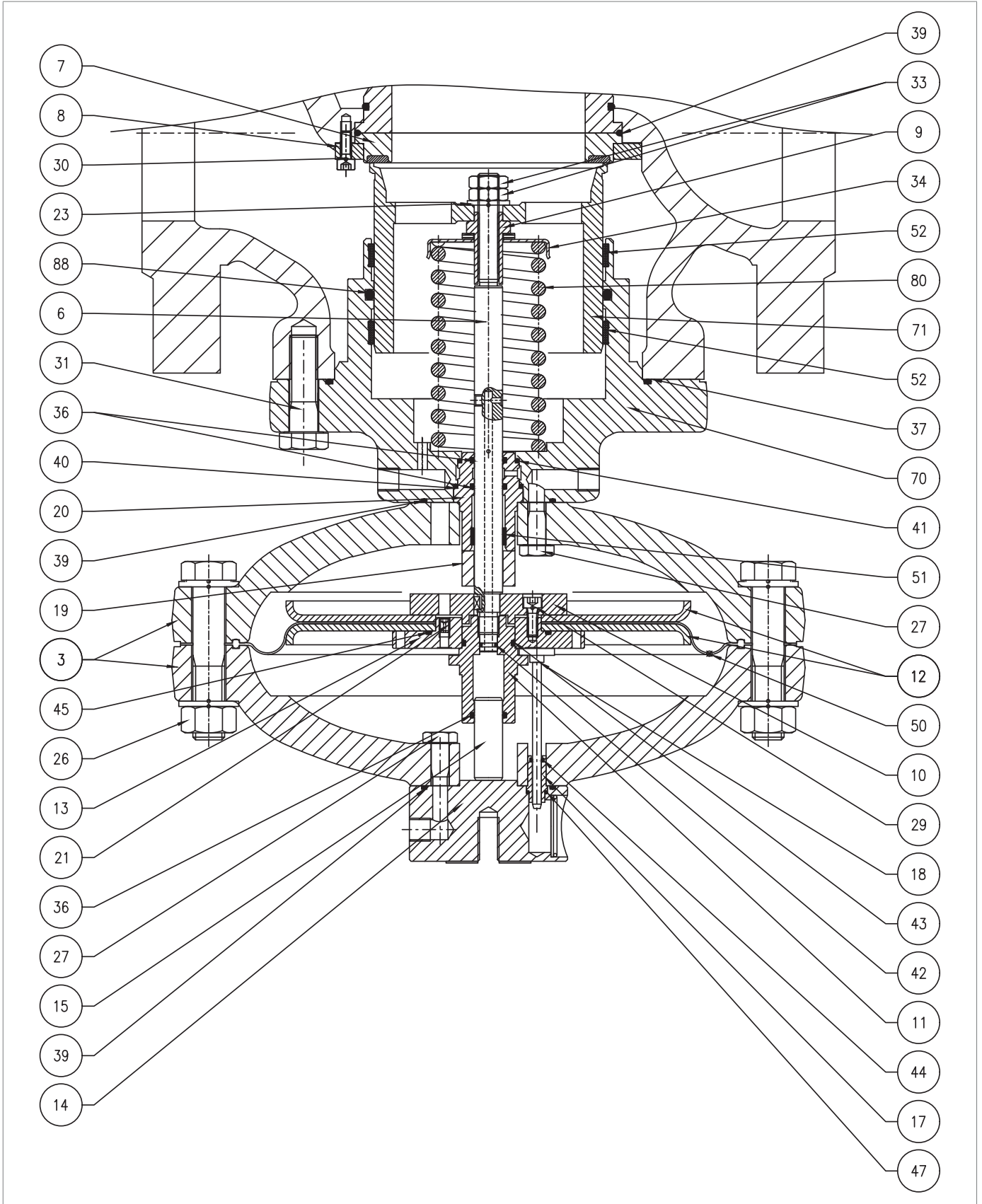

*Built-in monitor PM/819 3"÷ 4"*

Step	Action
60	<p>Position the washer (23) and the nuts (33), fixing them to the tightening torque indicated in the relative table.</p> <div style="border: 1px solid blue; padding: 5px;"> <p><b>! NOTICE!</b></p> <p><b>Before fitting the external nut (33), apply thread locking glue.</b></p> </div>
61	Position the reduction unit, supporting it carefully.
62	<p>Fit and fix the screws (31) according to the following tightening torques:</p> <ul style="list-style-type: none"> <li>• 3" : "Tab. 9.91";</li> <li>• 4" : "Tab. 9.92".</li> </ul> <div style="border: 1px solid blue; padding: 5px;"> <p><b>! NOTICE!</b></p> <p><b>Tighten the screws as shown in the diagram at "9.4.2.2 - Cross diagram for tightening screws".</b></p> </div>
63	Connect the connection pipes between the regulator, the monitor and their pilot units, including the downstream pressure outlets.

Tab. 9.130

**! WARNING!**

**Ensure that all parts have been fitted correctly.**

9.4.6.3 - BUILT-IN MONITOR PM/819 6"÷ 10"

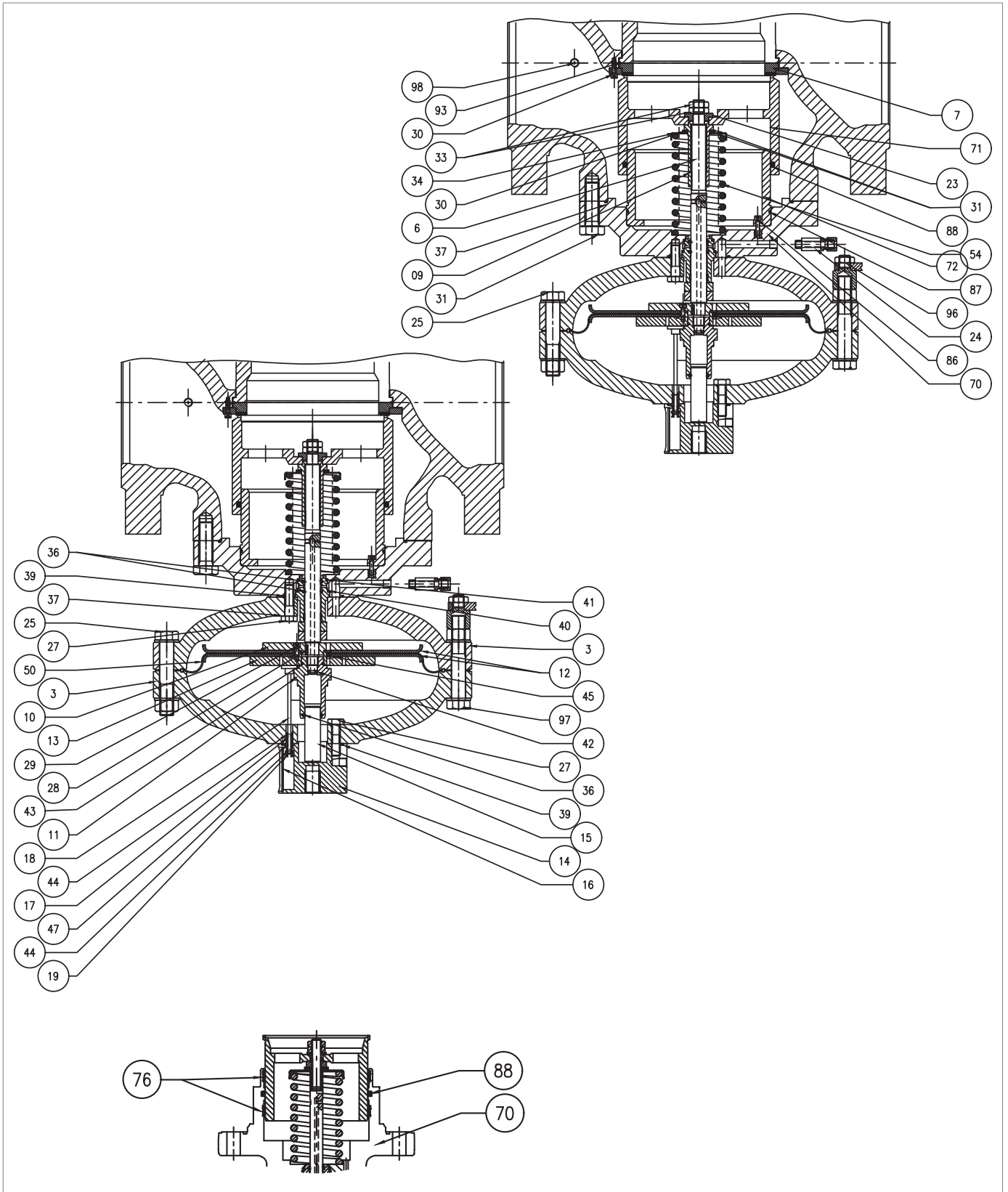
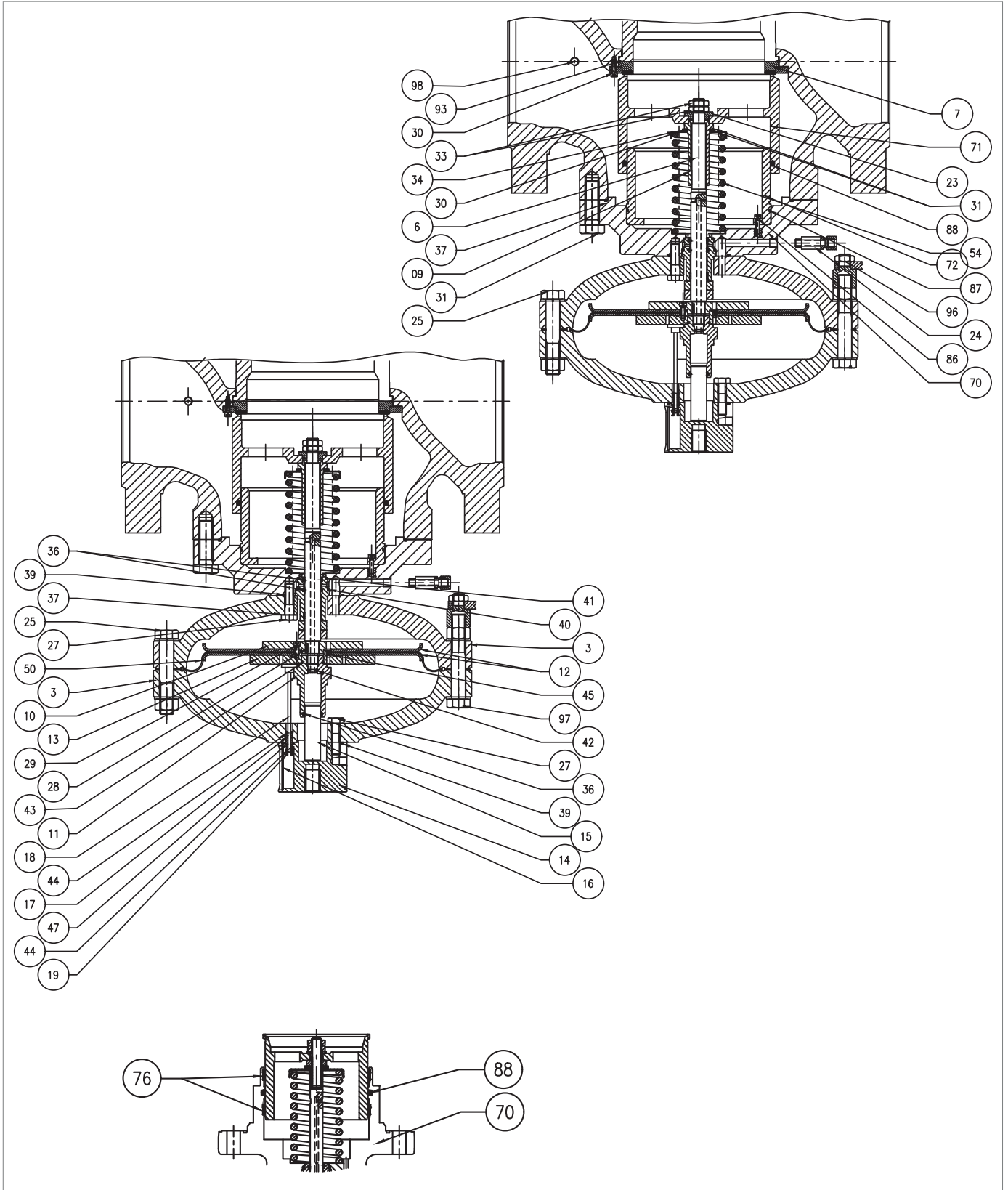

Fig. 9.64. Built-in monitor PM/819 6"÷ 10"

Step	Action
1	Disconnect the connection pipes between the regulator, the monitor and their pilot units, including the downstream pressure outlets.
2	Undo and remove the screws (31). <b>NOTICE!</b> <b>Support the head assembly during this step to avoid falls.</b>
3	Remove the reduction unit and place it on its side and on an anti-shock surface. <b>NOTICE!</b> <b>Take care not to damage the plug profile (71).</b>
4	Remove the O-ring (37) from the plug guide (70) and replace it, lubricating it with synthetic grease. <b>NOTICE!</b> <b>Before inserting the replacement O-ring, clean the retaining slots with a cleaning solution.</b>
5	Unscrew and remove the screws (30), the shaft collar (8) and the reinforced gasket (7), preventing them from falling. <b>NOTICE!</b> <b>Carefully prevent the sleeve from falling.</b>
6	Remove the O-ring (39) from the reinforced gasket (7) and replace it, lubricating it with synthetic grease. <b>NOTICE!</b> <b>Before inserting the replacement O-ring, clean the retaining slots with a cleaning solution.</b>
7	Position the reinforced gasket (7) and the shaft collar (8).
8	Insert and fix the screws (30) according to the following tightening torques: <ul style="list-style-type: none"> <li>• 6" : "Tab. 9.93";</li> <li>• 8" : "Tab. 9.94";</li> <li>• 10" : "Tab. 9.95".</li> </ul> <b>NOTICE!</b> <b>Tighten the screws as shown in the diagram at "9.4.2.2 - Cross diagram for tightening screws".</b>
9	Unscrew and remove the nuts (33) and the washer (23).
10	Remove the plug (71) and place it on an anti-shock surface.
11	Remove the O-ring (88) from the plug guide (71) and replace it, lubricating it with synthetic grease. <b>NOTICE!</b> <b>Before inserting the replacement O-ring, clean the retaining slots with a cleaning solution.</b>
12	Unscrew and remove the locking nut (9).
13	Remove the radial bearing (130), the spring support (34) and the spring (80).
14	Undo and remove the screws (86).
15	Take out the plug guide (72). <b>NOTICE!</b> <b>In this step, tighten some M6x50 screws into the threaded holes of the plug guide. Then screw them for vertical extraction, so that the plug guide always remains aligned.</b>
16	Remove the screws M6x50.



*Built-in monitor PM/819 6"÷ 10"*

Step	Action
17	Remove the O-ring (87) from the plug guide (72) and replace it, lubricating it with synthetic grease. <b>! NOTICE!</b> <b>Before inserting the replacement O-ring, clean the retaining slots with a cleaning solution.</b>
18	Put the plug guide (72) back in place.
19	Insert and fix the screws (86).
20	Remove the screws (57) together with the sight glass (16).
21	Remove the bush (63).
22	Remove the O-ring (44) from the bush (63) and replace it, lubricating it with synthetic grease. <b>! NOTICE!</b> <b>Before inserting the replacement O-ring, clean the retaining slots with a cleaning solution.</b>
23	Unscrew and remove the nuts (26) together with the screws (25, 98).
24	Remove the upper lid (3).
25	Remove the indicator rod (18) from the rod guide (17).
26	Undo and remove the screws of the upper section (27).
27	Separate the upper cover (3) from the eyebolt flange (14).
28	Take out the rod guide (17).
29	Remove the O-rings (39, 47) from the eyebolt flange (14) and replace them, lubricating them with synthetic grease. <b>! NOTICE!</b> <b>Before inserting the replacement O-rings, clean the retaining slots with a cleaning solution.</b>
30	Remove the O-ring (44) from the rod guide (17) and replace it, lubricating it with synthetic grease. <b>! NOTICE!</b> <b>Before inserting the replacement O-ring, clean the retaining slots with a cleaning solution.</b>
31	Place the rod guide (17) in the eyebolt flange (14).
32	Assemble the eyebolt flange (14) with the upper lid (3).
33	Insert and fix the screws of the upper section (27) according to the following tightening torques: <ul style="list-style-type: none"> <li>• 6" : "Tab. 9.93";</li> <li>• 8" : "Tab. 9.94";</li> <li>• 10" : "Tab. 9.95".</li> </ul> <b>! NOTICE!</b> <b>Tighten the screws as shown in the diagram at "9.4.2.2 - Cross diagram for tightening screws".</b>
34	Insert the indicator rod (18) into the rod guide (17).
35	Unscrew and remove the piston guide (11). <b>! NOTICE!</b> <b>In this step, keep the diaphragm unit still, fitting the compass wrench into the holes in the upper diaphragm support (13).</b>
36	Remove the balancing piston (15) from the piston guide (11).

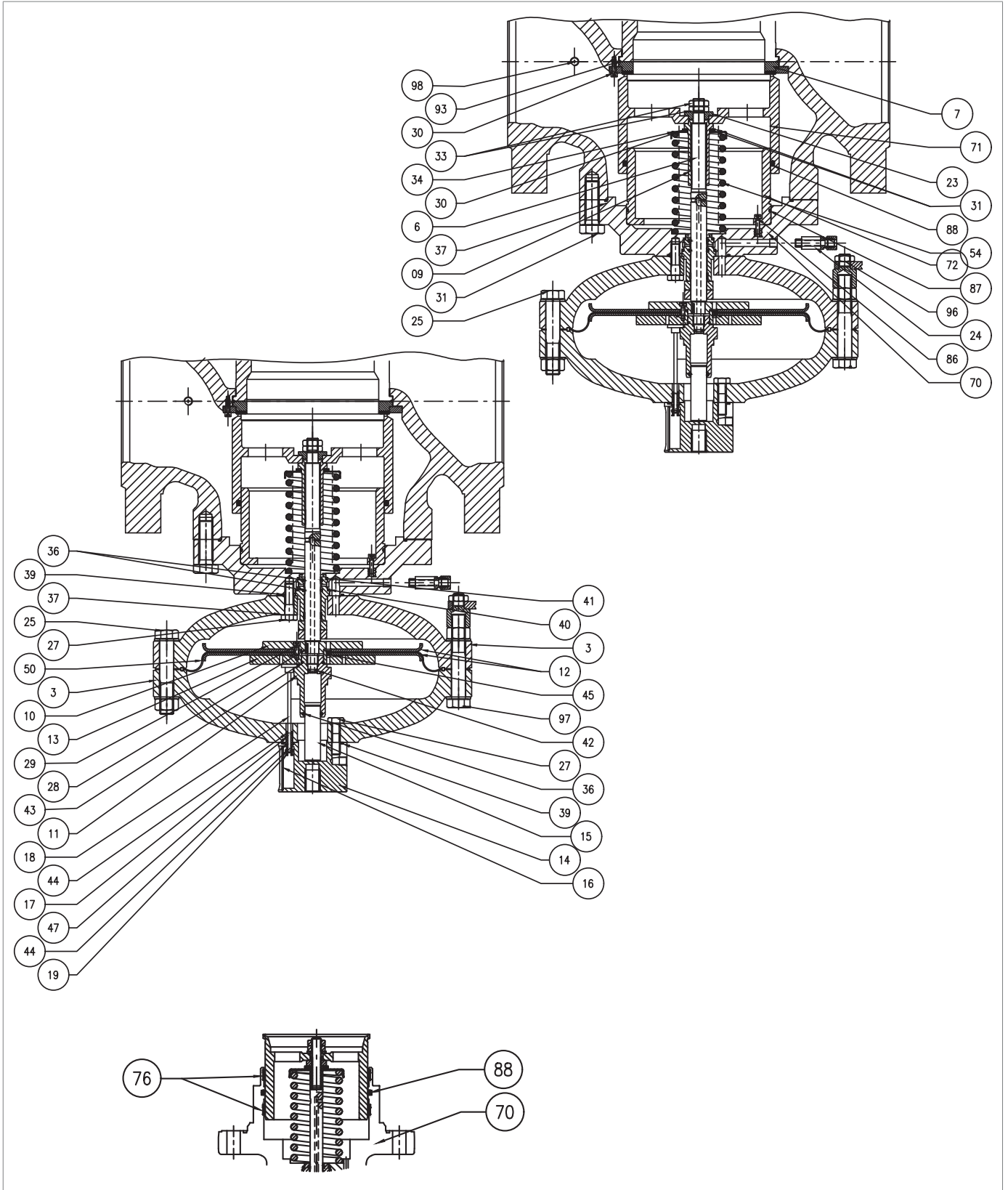

*Built-in monitor PM/819 6"÷ 10"*

Step	Action
37	Remove the O-rings (36, 43) from the eyebolt flange (11) and replace them, lubricating them with synthetic grease. <b>NOTICE!</b> <b>Before inserting the replacement O-rings, clean the retaining slots with a cleaning solution.</b>
38	Place the balancing piston (15) in the piston guide (11).
39	Take out the diaphragm unit.
40	Undo and remove the screws (29) from the lower diaphragm support (10).
41	Remove the lower diaphragm support (10) and the lower diaphragm protection disc (12).
42	Remove the diaphragm (50).
43	Remove the upper diaphragm support (13) from the upper diaphragm protection disc (12).
44	Remove and replace the O-ring (45) from the upper diaphragm support (13), lubricating it with synthetic grease. <b>NOTICE!</b> <b>Before inserting the replacement O-ring, clean the retaining slots with a cleaning solution.</b>
45	Put the upper diaphragm support (13) back in place into the upper diaphragm protection disc (12). <b>NOTICE!</b> <b>Check that the hole on the nozzle (21) is free from dirt or foreign bodies.</b>
46	Fit the new diaphragm (50). <b>NOTICE!</b> <b>Fit the diaphragm so that its convulsion is oriented towards the loading chamber.</b>
47	Put the lower diaphragm protection disc (12) and the lower diaphragm support (10) in place. <b>NOTICE!</b> <b>Check that the nozzle hole on the upper diaphragm support (13) is aligned with the hole on the lower diaphragm support (10).</b>
48	Apply thread locking glue to insert and fix the screws (29) according to the following tightening torques: <ul style="list-style-type: none"> <li>• 6" : "Tab. 9.93";</li> <li>• 8" : "Tab. 9.94";</li> <li>• 10" : "Tab. 9.95".</li> </ul> <b>NOTICE!</b> <b>Tighten the screws as shown in the diagram at "9.4.2.2 - Cross diagram for tightening screws".</b>
49	Remove the spacers (19, 64).
50	Undo and remove the screws of the lower section (27).
51	Remove the lower cover (3).
52	Remove the O-ring (39) from the plug guide (70) and replace it, lubricating it with synthetic grease. <b>NOTICE!</b> <b>Before inserting the replacement O-ring, clean the retaining slots with a cleaning solution.</b>
53	Remove the stem guide (20), the stem (6) and the key (28).

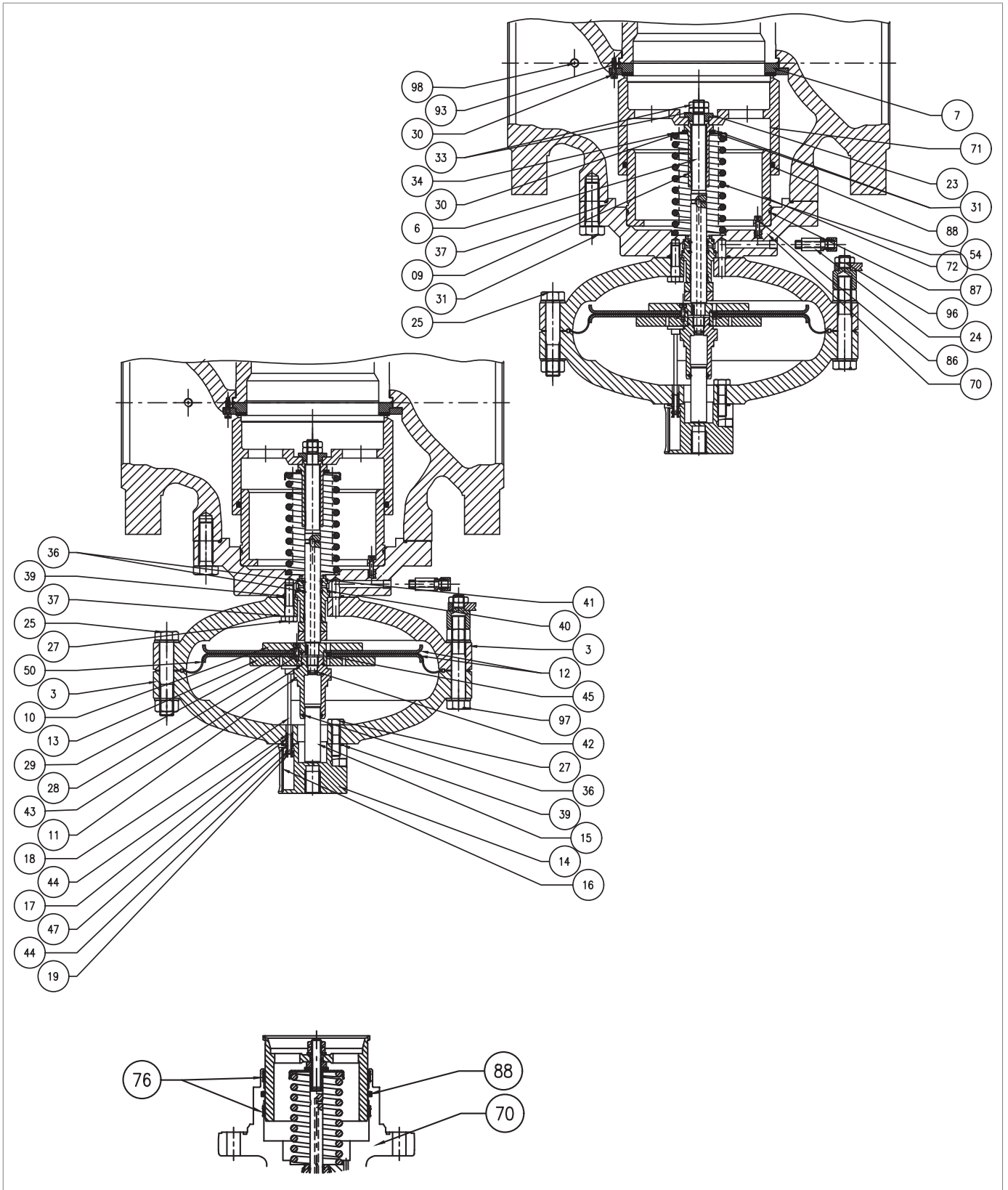

*Built-in monitor PM/819 6"÷ 10"*

Step	Action
54	<p>Remove the O-ring (41) from the plug guide (70) and replace it, lubricating it with synthetic grease.</p> <p><b>! NOTICE!</b></p> <p><b>Before inserting the replacement O-ring, clean the retaining slots with a cleaning solution.</b></p>
55	<p>Remove the O-rings (40) from the stem guide (20) and replace them, lubricating them with synthetic grease.</p> <p><b>! NOTICE!</b></p> <p><b>Before inserting the replacement O-ring, clean the retaining slots with a cleaning solution.</b></p>
56	<p>Remove and replace the I/DWR rings (51) from the stem guide (20).</p> <p><b>! NOTICE!</b></p> <p><b>Before inserting the replacement I/DWR, clean the retaining slots with a cleaning solution.</b></p>
57	<p>Remove the O-rings (36) from the stem guide (20) and replace them, lubricating them with synthetic grease.</p> <p><b>! NOTICE!</b></p> <p><b>Before inserting the replacement O-rings, clean the retaining slots with a cleaning solution.</b></p>
58	<p>Remove the O-ring (42) from the stem (6) and replace it, lubricating it with synthetic grease.</p> <p><b>! NOTICE!</b></p> <p><b>Before inserting the replacement O-ring, clean the retaining slots with a cleaning solution.</b></p>
59	<p>Remove the stem guide (20), the stem (6) and the key (28).</p> <p><b>! NOTICE!</b></p> <ul style="list-style-type: none"> <li>• Lubricate the rod surface with silicone grease;</li> <li>• Make sure that the key (28) is in the correct position in the stem (6).</li> </ul>
60	<p>Put the lower lid (3) in place and fix it on the plug guide (70).</p> <p><b>! NOTICE!</b></p> <p><b>The hole for the passage of the loading pressure must match the similar one on the plug guide.</b></p>
61	<p>Insert and fix the screws of the lower section (27) according to the following tightening torque:</p> <ul style="list-style-type: none"> <li>• 6" : "Tab. 9.93";</li> <li>• 8" : "Tab. 9.94";</li> <li>• 10" : "Tab. 9.95".</li> </ul> <p><b>! NOTICE!</b></p> <p><b>Tighten the screws as shown in the diagram at "9.4.2.2 - Cross diagram for tightening screws".</b></p>
62	<p>Place the spacers (19, 64).</p>
63	<p>Put the diaphragm unit in place.</p> <p><b>! NOTICE!</b></p> <p><b>Before inserting the diaphragm unit, clean the retaining slots with a cleaning solution.</b></p>

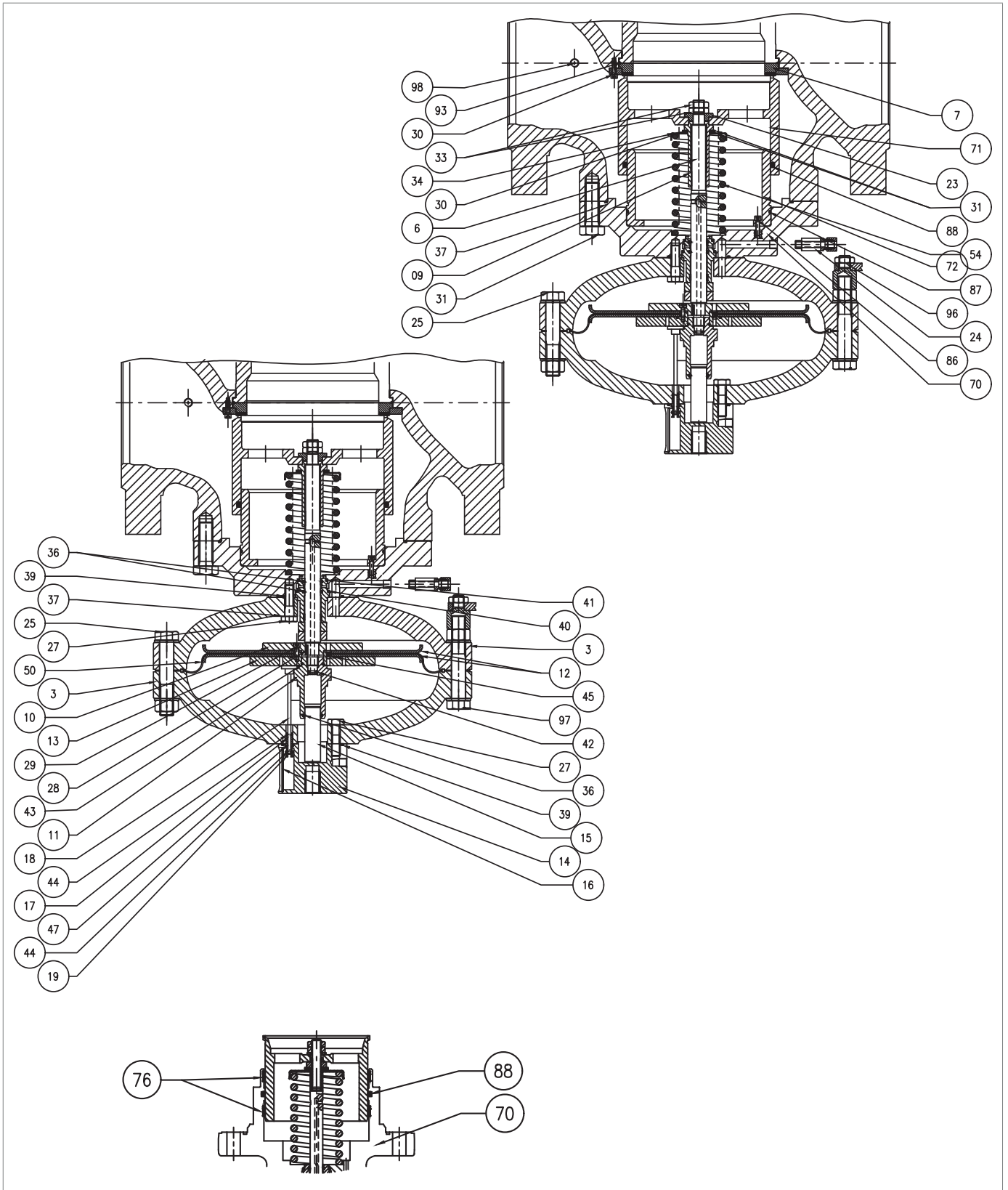

*Built-in monitor PM/819 6"÷ 10"*

Step	Action
64	<p>Insert and fix the piston guide (11) according to the following tightening torques:</p> <ul style="list-style-type: none"> <li>6" : "Tab. 9.93";</li> <li>8" : "Tab. 9.94";</li> <li>10" : "Tab. 9.95".</li> </ul> <div style="border: 1px solid black; padding: 5px;"> <p><b>! NOTICE!</b></p> <p><b>In this step, keep the diaphragm unit still, fitting the compass wrench into the holes in the upper diaphragm support (13).</b></p> </div>
65	<p>Put the upper lid (3) in place, taking care to fit the indicator rod (18) into the gap between the upper diaphragm support (13) and the piston guide (11).</p> <div style="border: 1px solid black; padding: 5px;"> <p><b>! NOTICE!</b></p> <ul style="list-style-type: none"> <li><b>The indicator rod (18) must not obstruct the hole on the upper diaphragm support (13);</b></li> <li><b>The eyebolt flange stroke indicator (14) must be perpendicular to the gas flow and visible.</b></li> </ul> </div>
66	<p>Insert and fix the screws (25, 98) with the nuts (26) according to the following tightening torques:</p> <ul style="list-style-type: none"> <li>6" : "Tab. 9.93";</li> <li>8" : "Tab. 9.94";</li> <li>10" : "Tab. 9.95".</li> </ul> <div style="border: 1px solid black; padding: 5px;"> <p><b>! NOTICE!</b></p> <p><b>Tighten the screws as shown in the diagram at "9.4.2.2 - Cross diagram for tightening screws".</b></p> </div>
67	Put the spring (80) and spring support back (34) back in place.
68	<p>Insert and fix the lock nut (9) together with the radial bearing (130) according to the tightening torques:</p> <ul style="list-style-type: none"> <li>6" : "Tab. 9.93";</li> <li>8" : "Tab. 9.94";</li> <li>10" : "Tab. 9.95".</li> </ul> <div style="border: 1px solid black; padding: 5px;"> <p><b>! NOTICE!</b></p> <p><b>Before fixing the lock nut (9), check that the spring (80) is well seated in the appropriate centring stop on the plug guide (70).</b></p> </div>
69	Put the plug (71) in place lubricating the surface with silicone grease.
70	<p>Apply thread locking glue to insert and fix the washer (23) and the nuts (33) according to the following tightening torques:</p> <ul style="list-style-type: none"> <li>6" : "Tab. 9.93";</li> <li>8" : "Tab. 9.94";</li> <li>10" : "Tab. 9.95".</li> </ul>
71	Position the reduction unit, supporting it carefully.
72	<p>Fit and fix the screws (31) according to the following tightening torques:</p> <ul style="list-style-type: none"> <li>6" : "Tab. 9.93";</li> <li>8" : "Tab. 9.94";</li> <li>10" : "Tab. 9.95".</li> </ul> <div style="border: 1px solid black; padding: 5px;"> <p><b>! NOTICE!</b></p> <p><b>Tighten the screws as shown in the diagram at "9.4.2.2 - Cross diagram for tightening screws".</b></p> </div>
73	Reposition the connecting pipes between the regulator and the monitor and their respective pilot assemblies, including the downstream pressure taps.

Tab. 9.131

**! WARNING!**

**Ensure that all parts have been fitted correctly.**

**9.4.7 - 200/A SERIES PILOT + PRE-REDUCER R14/A MAINTENANCE**

**9.4.7.1 - 200/A SERIES PILOT DISCONNECTION**

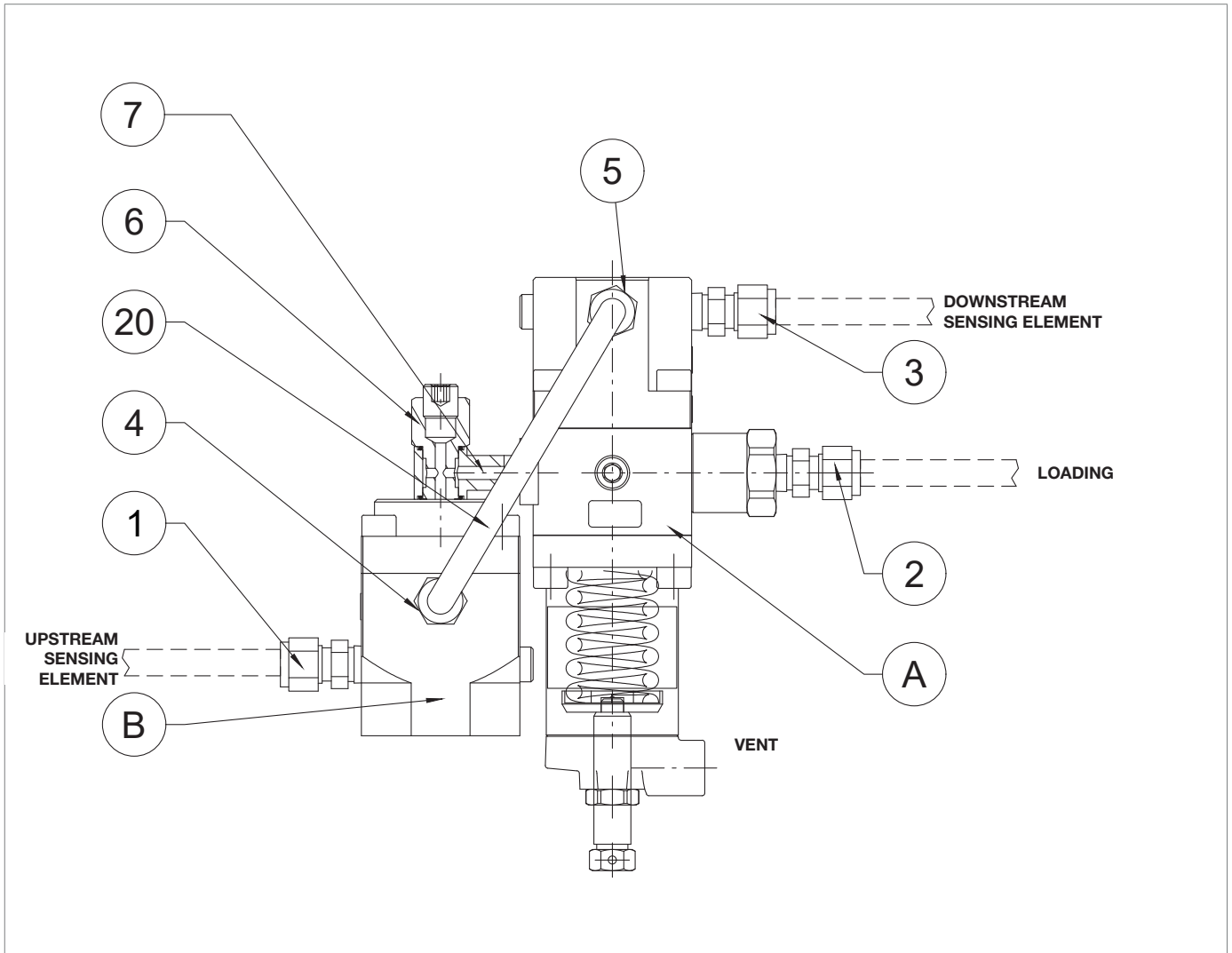

Fig. 9.65. Pilot 200/A

To disconnect, proceed as follows:

Step	Action
1	Disconnect the sensing lines between the 200/A pilot and the regulator by adjusting the fittings (1, 2, 3).
2	Unscrew and remove the fixing screw to remove the pilot from the regulator.
3	Remove the pipe (20) by adjusting the fittings (4, 5).
4	Unscrew and remove the screw (6) to separate the R14/A pre-regulator from the pilot.
5	Undo and remove the screw (7) from pilot 200/A.

Tab. 9.132

To reconnect the pilot, proceed as follows:

Step	Action
1	Insert and fix the screw (7) to the 200/A pilot.
2	Insert and fix the screw (6) to connect the R14/A pre-regulator to the 200/A pilot.
3	Connect the pipe (20) by adjusting the fittings (4, 5).
4	Insert and fix the fixing screw to connect the pilot to the regulator.
5	Connect the sensing lines between the pilot and the regulator by adjusting the fittings (1, 2, 3).

Tab. 9.133

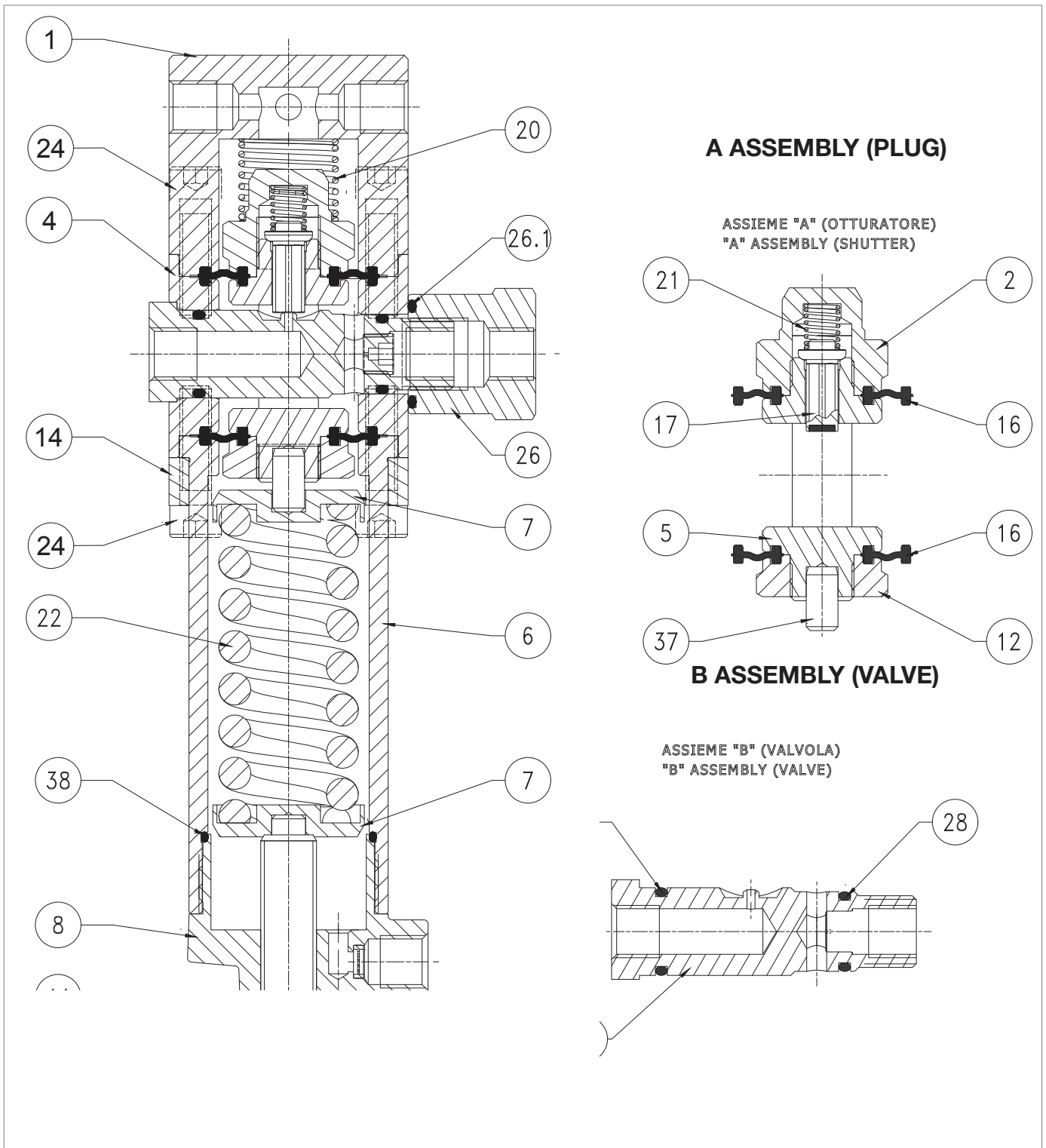



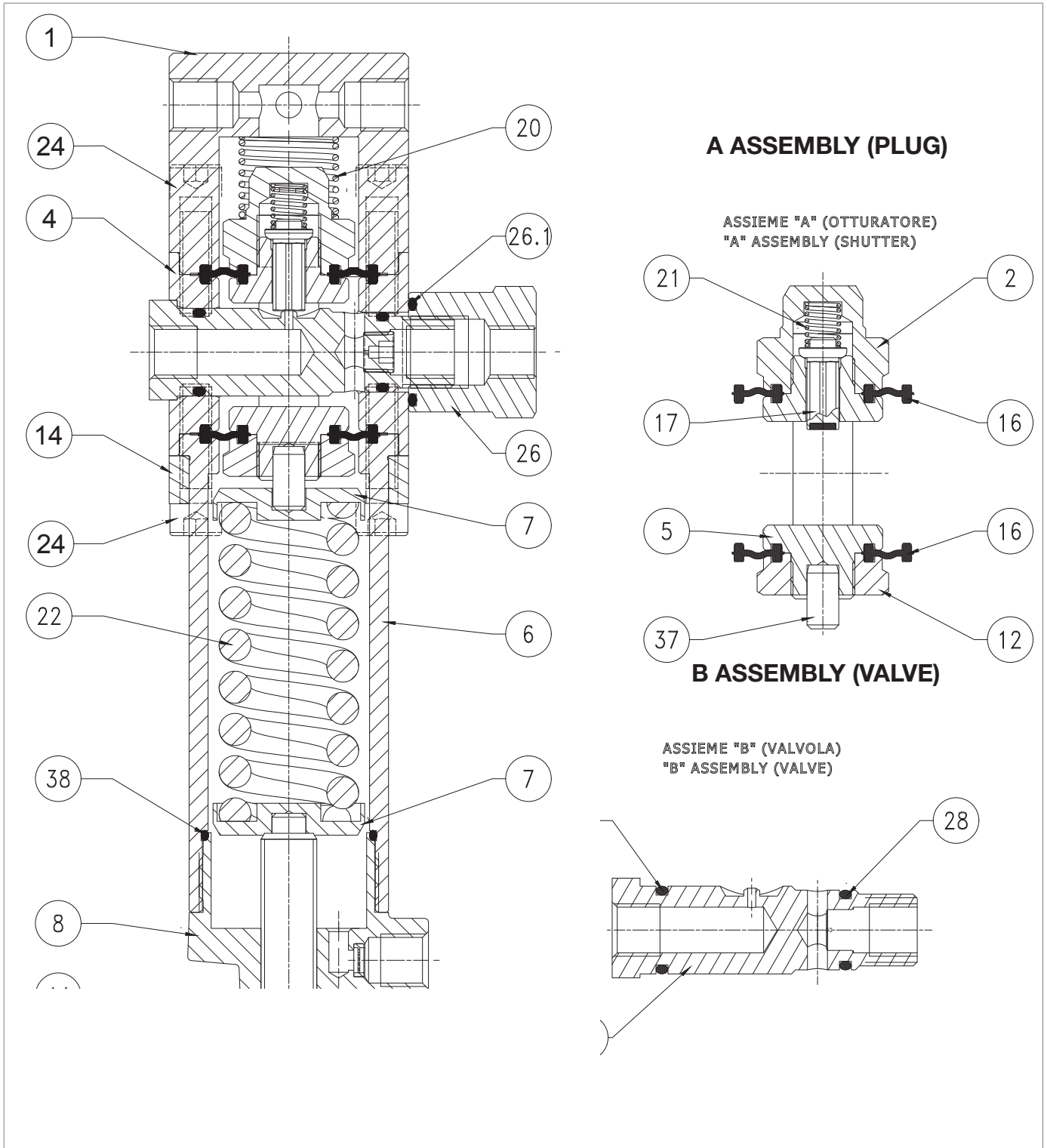

Fig. 9.66. Pilot 204/A - 205/A

Step	Action
1	Loosen the nut (9).
2	Completely release the spring (22) by turning the adjusting screw (10).
3	Remove the adjusting screw (10) together with the cap (9).
4	Remove the cap (8).
	Remove the O-ring (38) from the cap (8) and replace it, lubricating it with synthetic grease.
5	 <b>NOTICE!</b> <b>Before inserting the replacement O-ring, clean the retaining slots with a cleaning solution.</b>
6	Remove the spring (22) and the spring supports (7).
7	Undo and remove the screws of the lower section (24).
8	Remove the bracket (14) from the sleeve (6).
9	Remove the sleeve (6).
10	Undo and remove the screws of the upper section (24).
11	Remove the pilot cover (1).
12	Remove the spring (20).
13	Unscrew and remove the nut (26).
	Remove the O-ring (26.1) from the nut (26) and replace it, lubricating it with synthetic grease.
14	 <b>NOTICE!</b> <b>Before inserting the replacement O-ring, clean the retaining slots with a cleaning solution.</b>
15	Pull out the "B" (valve) assembly.
	Remove the O-rings (28, 29) from the valve seat (3) and replace them, lubricating them with synthetic grease.
16	 <b>NOTICE!</b> <b>Before inserting the replacement O-ring, clean the retaining slots with a cleaning solution.</b>
17	Remove assembly "A" (plug) from the valve body (4) by pushing it from the top downwards.
18	Unscrew and remove the pilot nut (2).
	Remove the O-ring (18) of the pilot nut (2) and replace it, lubricating it with synthetic grease.
19	 <b>NOTICE!</b> <b>Before inserting the replacement O-ring, clean the retaining slots with a cleaning solution.</b>
20	Remove the spring (21).
21	Remove and replace the plug (17).
22	Remove the upper protection disc (15).
	Remove and replace the upper diaphragm (16), lubricating the lanyards with synthetic grease.
23	 <b>NOTICE!</b> <b>Before inserting the replacement diaphragm, clean the retaining slots with a cleaning solution.</b>
24	Unscrew and remove the nut (25).
25	Remove the lower protection disc (15).



Pilot 204/A - 205/A

Step	Action
26	Remove and replace the lower diaphragm (16), lubricating the lanyards with synthetic grease. <b>NOTICE!</b> <b>Before inserting the replacement diaphragm, clean the retaining slots with a cleaning solution.</b>
27	Fit the lower protection disc (15).
28	Fix the nut (25) according to the following tightening torque: • Pilot 204/A-205/A: "Tab. 9.96".
29	Fit the plug (17) and then the spring (21).
30	Fit the upper protection disc (15).
31	Fix the pilot nut (2) according to the following tightening torque: • Pilot 204/A-205/A: "Tab. 9.96".
32	Insert assembly "A" (plug) from top to bottom into the valve body (4). <b>NOTICE!</b> • <b>Take care not to damage the diaphragms (16) during this step</b> • <b>Make sure the marking on the lower section of the headframe is parallel to the axis of the hole for inserting the seat (3) into the valve body (4).</b>
33	Insert assembly "B" (valve) into the valve body (4). <b>NOTICE!</b> <b>Take care not to damage the O-rings (28, 29) and the valve seat (3).</b>
34	Screw in the nut (26) according to the following tightening torque: • Pilot 204/A-205/A: "Tab. 9.96".
35	Fit the spring (20).
36	Fit the cover (1).
37	Insert and fix the screws of the upper section (24) according to the following tightening torque: • Pilot 204/A-205/A: "Tab. 9.96".
38	Fit the sleeve (6) and the bracket (14).
39	Insert and fix the screws of the lower section (24) according to the following tightening torque: • Pilot 204/A-205/A: "Tab. 9.96".
40	Fit the spring (22) and the spring supports (7).
41	Unscrew the cap (8).
42	Remove and replace the O-ring (11) in the nut (9). <b>NOTICE!</b> <b>Before inserting the replacement O-ring, clean the retaining slots with a cleaning solution.</b>
43	Fit the adjusting screw (10) together with the cap (9).

Tab. 9.134

**WARNING!**

**Ensure that all parts have been fitted correctly.**

9.4.7.3 - PILOT 207/A

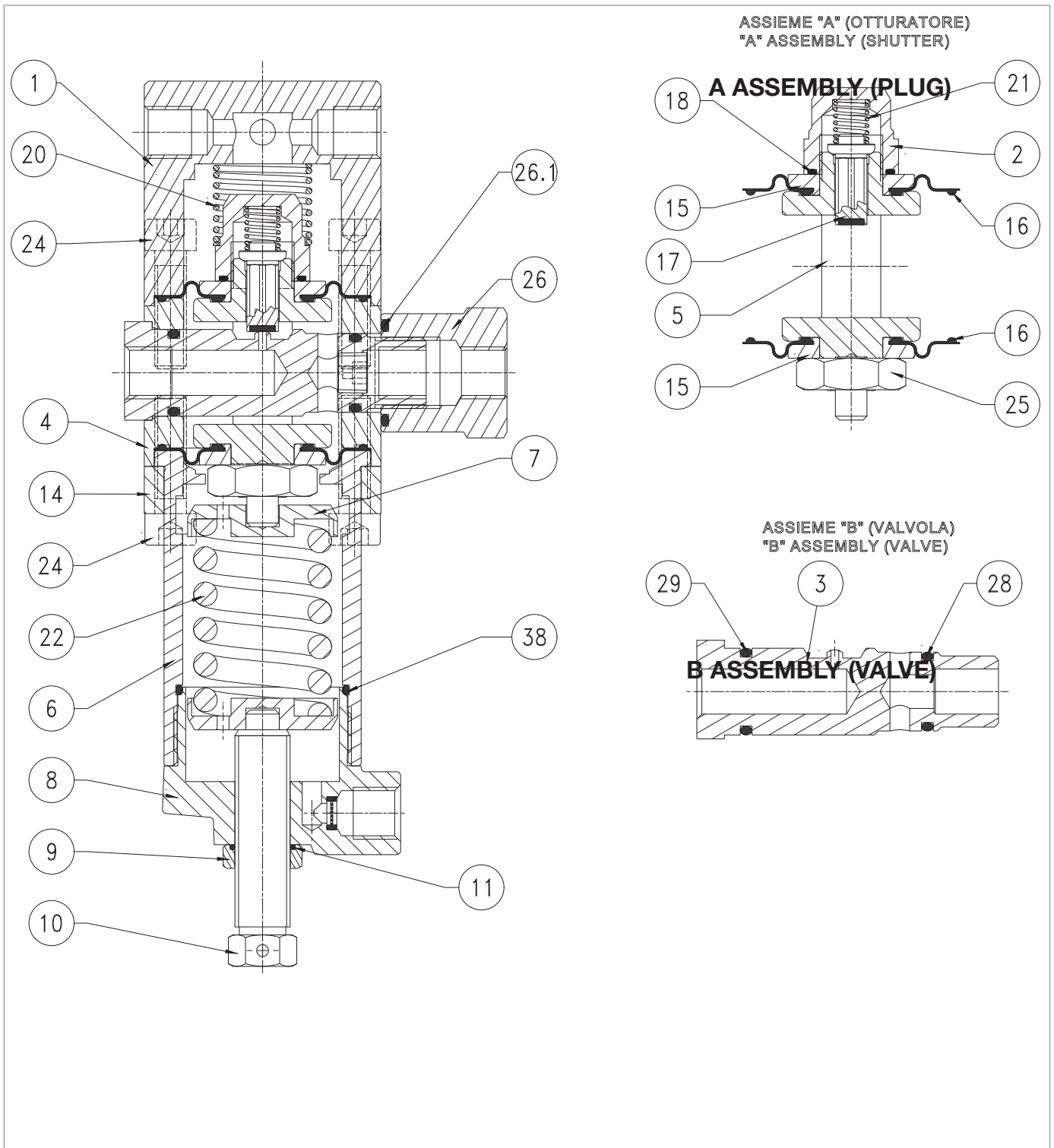





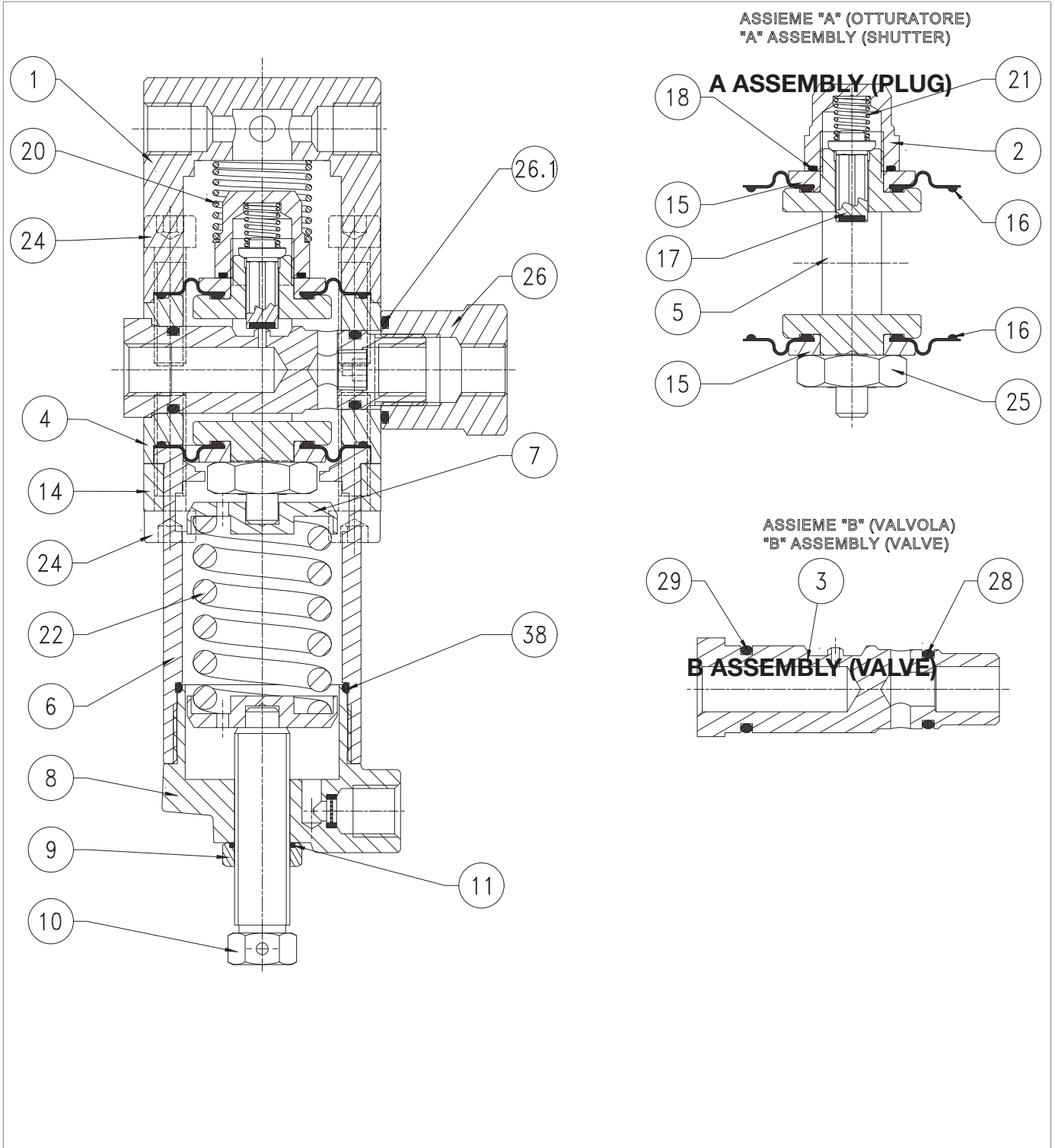





Fig. 9.67. Pilot 207/A

Step	Action
1	Loosen the nut (9).
2	Completely release the spring (22) by turning the adjusting screw (10).
3	Remove the adjusting screw (10) together with the cap (9).
4	Remove the cap (8).
	Remove the O-ring (38) from the cap (8) and replace it, lubricating it with synthetic grease.
5	<div style="border: 1px solid black; padding: 5px;">  <b>NOTICE!</b>  <b>Before inserting the replacement O-ring, clean the retaining slots with a cleaning solution.</b> </div>
6	Remove the spring (22) and the spring supports (7).
7	Undo and remove the screws of the lower section (24).
8	Remove the bracket (14) from the sleeve (6).
9	Remove the sleeve (6).
10	Undo and remove the screws of the upper section (24).
11	Remove the pilot cover (1).
12	Remove the spring (20).
13	Unscrew and remove the nut (26).
	Remove the O-ring (26.1) from the nut (26) and replace it, lubricating it with synthetic grease.
14	<div style="border: 1px solid black; padding: 5px;">  <b>NOTICE!</b>  <b>Before inserting the replacement O-ring, clean the retaining slots with a cleaning solution.</b> </div>
15	Unscrew and remove the pilot nut (2).
16	Remove the spring (21).
17	Remove and replace the plug (17).
18	Remove and replace the upper diaphragm (16).
19	Pull out the "B" (valve) assembly.
	Remove the O-rings (28, 29) from the valve seat (3) and replace them, lubricating them with synthetic grease.
20	<div style="border: 1px solid black; padding: 5px;">  <b>NOTICE!</b>  <b>Before inserting the replacement O-rings, clean the retaining slots with a cleaning solution.</b> </div>
21	Remove assembly "A" (plug) from the valve body (4) by pushing it from the top downwards.
22	Unscrew and remove the nut (12).
	Remove and replace the lower diaphragm (16), lubricating the lanyards with synthetic grease.
23	<div style="border: 1px solid black; padding: 5px;">  <b>NOTICE!</b>  <b>Before inserting the replacement diaphragm, clean the retaining slots with a cleaning solution.</b> </div>
24	Place and fix the nut (12) according to the following tightening torque: <ul style="list-style-type: none"> <li>Pilot 207/A: "Tab. 9.97".</li> </ul>
	Insert assembly "A" (plug) from top to bottom into the valve body (4).
25	<div style="border: 1px solid black; padding: 5px;">  <b>NOTICE!</b>  <ul style="list-style-type: none"> <li>Take care not to damage the diaphragms (16) during this step.</li> <li>Make sure the marking on the lower section of the headframe is parallel to the axis of the hole for inserting the seat (3) into the valve body (4).</li> </ul> </div>



Pilot 207/A

Step	Action
26	Insert assembly "B" (valve) into the valve body (4). <div style="border: 1px solid black; padding: 5px;">  <b>NOTICE!</b>  <b>Take care not to damage the O-rings (28, 29) and the valve seat (3).</b> </div>
27	Screw in the nut (26) according to the following tightening torque: <ul style="list-style-type: none"> <li>Pilot 207/A: "Tab. 9.97"</li> </ul>
28	Put the upper diaphragm (16) back in place, lubricating the lanyards with synthetic grease. <div style="border: 1px solid black; padding: 5px;">  <b>NOTICE!</b>  <b>Before inserting the replacement diaphragm, clean the retaining slots with a cleaning solution.</b> </div>
29	Put the plug (17) and then the spring (21) back in place.
30	Refit and fix the pilot nut (2) according to the following tightening torque: <ul style="list-style-type: none"> <li>Pilot 207/A: "Tab. 9.97".</li> </ul>
31	Fit the spring (20).
32	Fit the cover (1).
33	Insert and fix the screws of the upper section (24) according to the following tightening torque: <ul style="list-style-type: none"> <li>Pilot 207/A: "Tab. 9.97".</li> </ul>
34	Fit the sleeve (6) and the bracket (14).
35	Insert and fix the screws of the lower section (24) according to the following tightening torque: <ul style="list-style-type: none"> <li>Pilot 207/A: "Tab. 9.97".</li> </ul>
36	Fit the spring (22) and the spring supports (7).
37	Unscrew the cap (8).
38	Remove and replace the O-ring (11) in the nut (9). <div style="border: 1px solid black; padding: 5px;">  <b>NOTICE!</b>  <b>Before inserting the replacement O-ring, clean the retaining slots with a cleaning solution.</b> </div>
39	Fit the adjusting screw (10) together with the cap (9).

Tab. 9.135

 **WARNING!**

**Ensure that all parts have been fitted correctly.**

**9.4.7.4 - 200/A SERIES PILOT RECONNECTION**

 **NOTICE!**

**To reconnect the pilot to the regulator, refer to table "Tab. 9.133".**

9.4.7.5 - PRE-REGULATOR R14/A

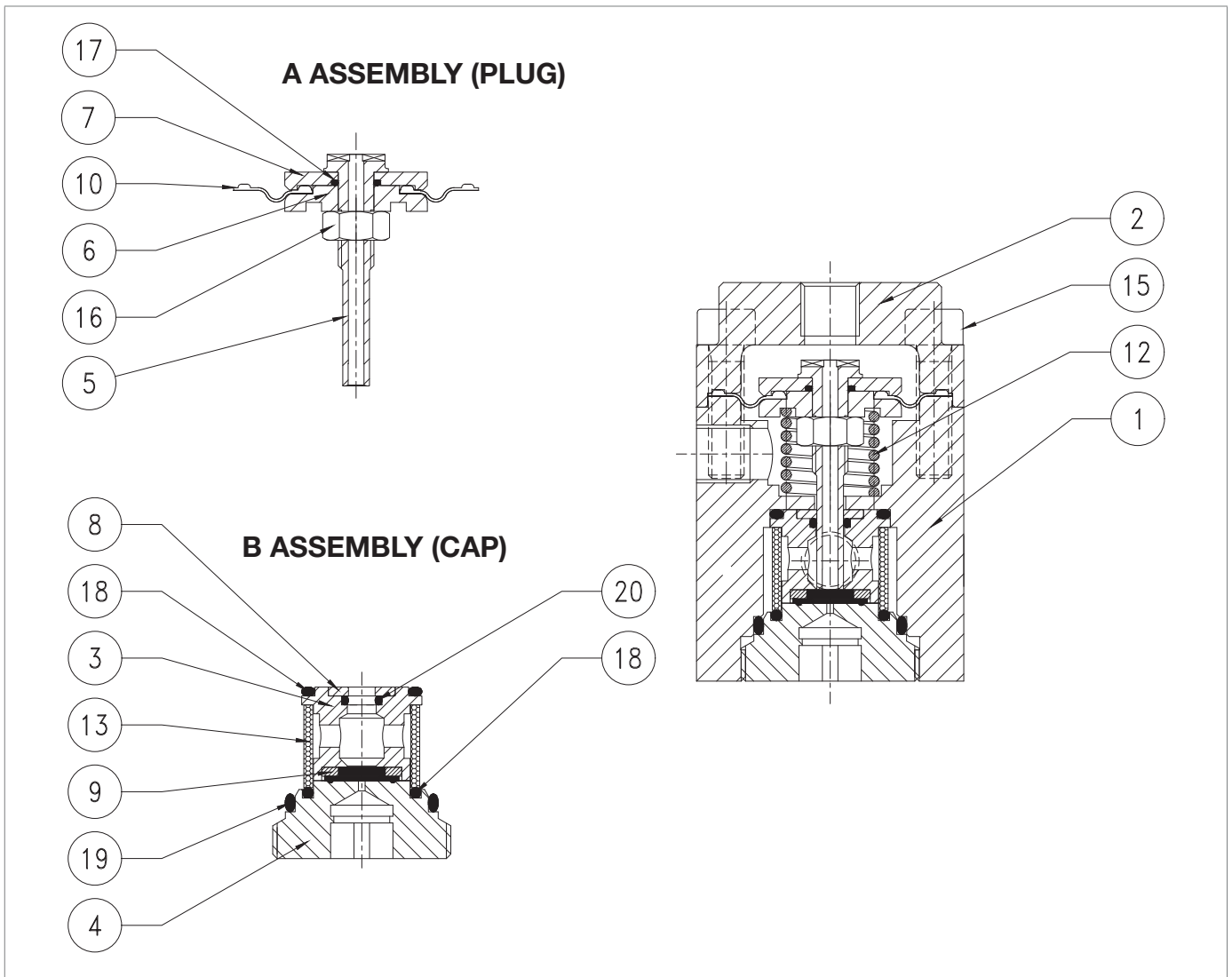





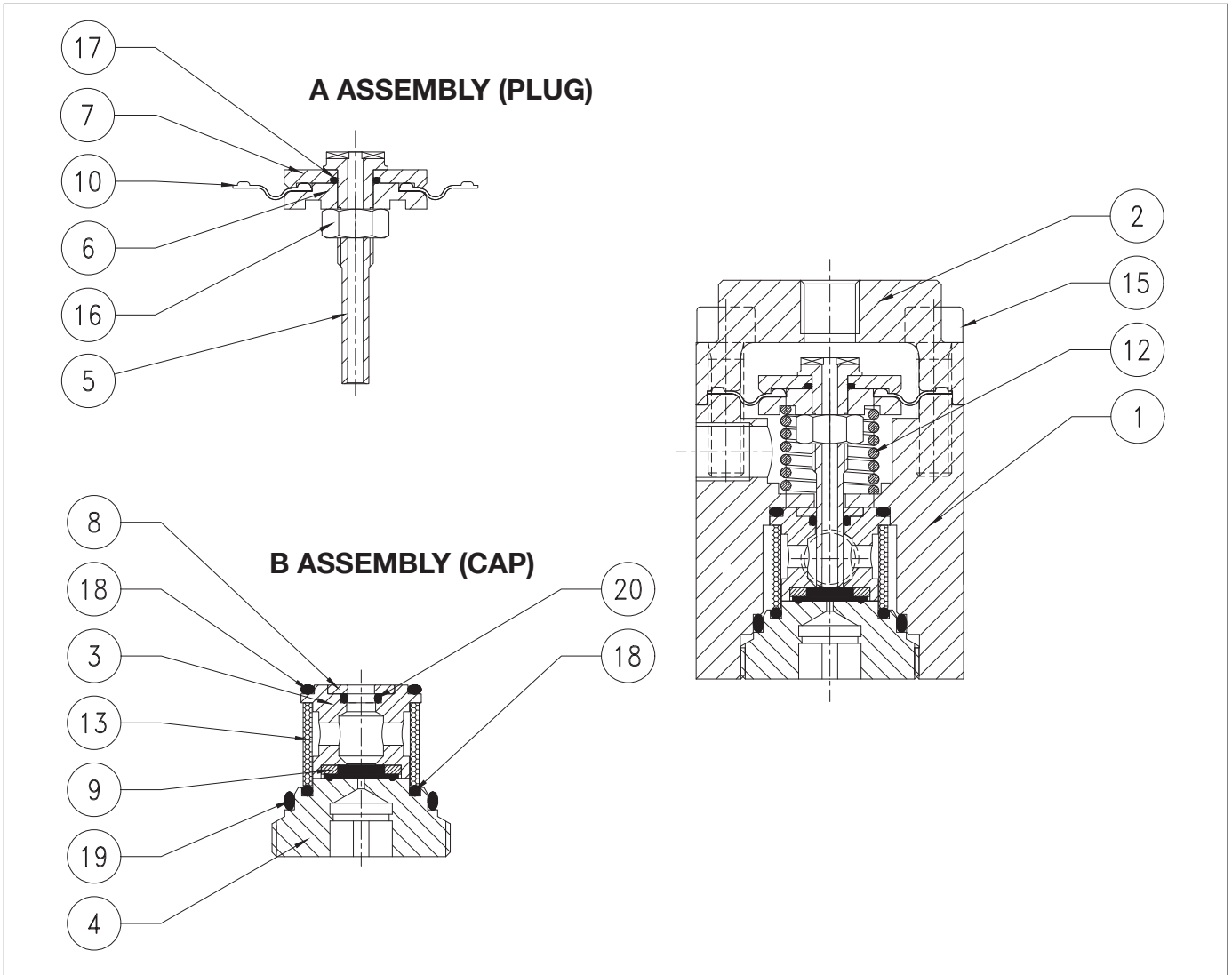

Fig. 9.68. Pre-regulator R14/A

Step	Action
1	Undo and remove the screws (15).
2	Remove the cover (2)
3	Pull out the "A" (plug) assembly.
4	Remove the spring (12).
5	Unscrew and remove the nut (16).
6	Insert the diaphragm protection disc (6) and the diaphragm (10).
7	Remove and replace the O-ring (17) from the diaphragm protection disc (7), lubricating it with synthetic grease. <div style="border: 1px solid black; padding: 5px;">  <b>NOTICE!</b>  <b>Before inserting the replacement O-ring, clean the retaining slots with a cleaning solution.</b> </div>
8	Remove and replace the gasket (10). <div style="border: 1px solid black; padding: 5px;">  <b>NOTICE!</b>  <b>Before inserting the replacement diaphragm, clean the retaining slots with a cleaning solution.</b> </div>
9	Fit the diaphragm protection disc (7).
10	Fit and fix the nut (16) into the plug (5) according to the following tightening torque: <ul style="list-style-type: none"> <li>R14/A: "Tab. 9.98".</li> </ul>
11	Unscrew and remove assembly "B" (cap) by adjusting the cap (4).
12	Take out the plug guide (3).
13	Remove the O-ring (18) from the plug guide (3) and replace it, lubricating it with synthetic grease. <div style="border: 1px solid black; padding: 5px;">  <b>NOTICE!</b>  <b>Before inserting the replacement O-ring, clean the retaining slots with a cleaning solution.</b> </div>
14	Remove the ring (8).
15	Remove the O-ring (20) from the plug guide (3) and replace it, lubricating it with synthetic grease. <div style="border: 1px solid black; padding: 5px;">  <b>NOTICE!</b>  <b>Before inserting the replacement O-ring, clean the retaining slots with a cleaning solution.</b> </div>
16	Remove and replace the reinforced gasket (9). <div style="border: 1px solid black; padding: 5px;">  <b>NOTICE!</b>  <b>Before inserting the replacement O-ring, clean the retaining slots with a cleaning solution.</b> </div>
17	Remove and replace the filter (13).
18	Remove the O-rings (18, 19) from the cap (4) and replace them, lubricating them with synthetic grease. <div style="border: 1px solid black; padding: 5px;">  <b>NOTICE!</b>  <b>Before inserting the replacement O-rings, clean the retaining slots with a cleaning solution.</b> </div>
19	Put the filter (13) and the plug guide (3) in place.



Pre-regulator R14/A

Step	Action
20	Position the ring (8).
21	Position and secure the "B" assembly (cap). <b>NOTICE!</b> <b>Take care not to damage the O-rings (18, 19) during this step.</b>
22	Fit the spring (12).
23	Insert assembly "A" (plug) into the body (1). <b>NOTICE!</b> <b>Before inserting the plug unit, lubricate the plug surface with silicone grease.</b>
24	Fit the cover (2).
25	Insert and fix the screws (15) according to the following tightening torque: • R14/A: "Tab. 9.98". <b>NOTICE!</b> <b>Tighten the screws as shown in the diagram at "9.4.2.2 - Cross diagram for tightening screws".</b>

Tab. 9.136

**WARNING!**

**Ensure that all parts have been fitted correctly.**

#### 9.4.7.6 - REASSEMBLY OF THE PILOT UNIT

Step	Action
1	Connect the connecting sockets between the 200/A series pilot and the R14/A pre-reducer by screwing on the conical fittings.

Tab. 9.137

**WARNING!**

**Ensure that all parts have been fitted correctly.**

**9.4.8 - M/A THROTTLE VALVE MAINTENANCE**

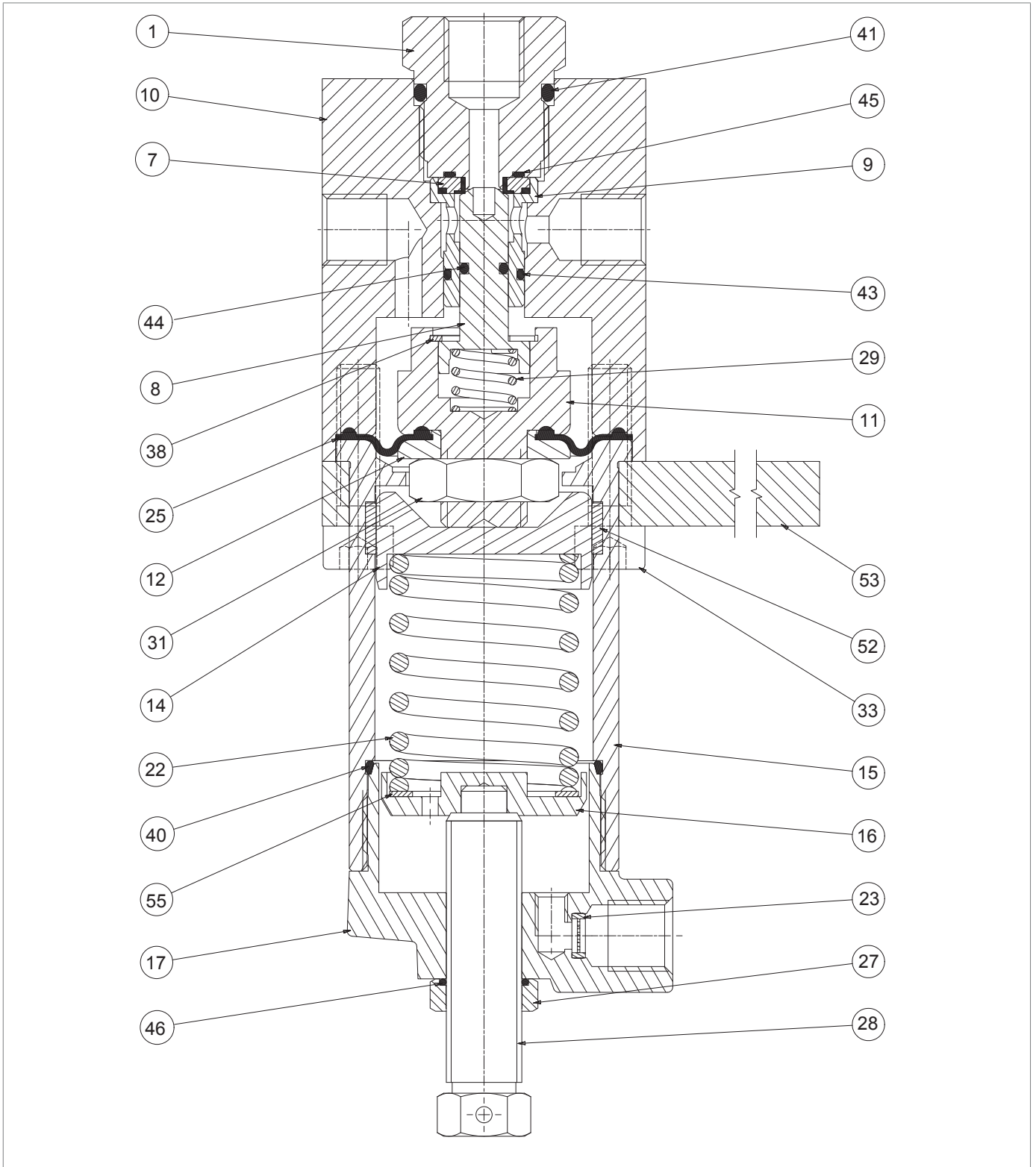





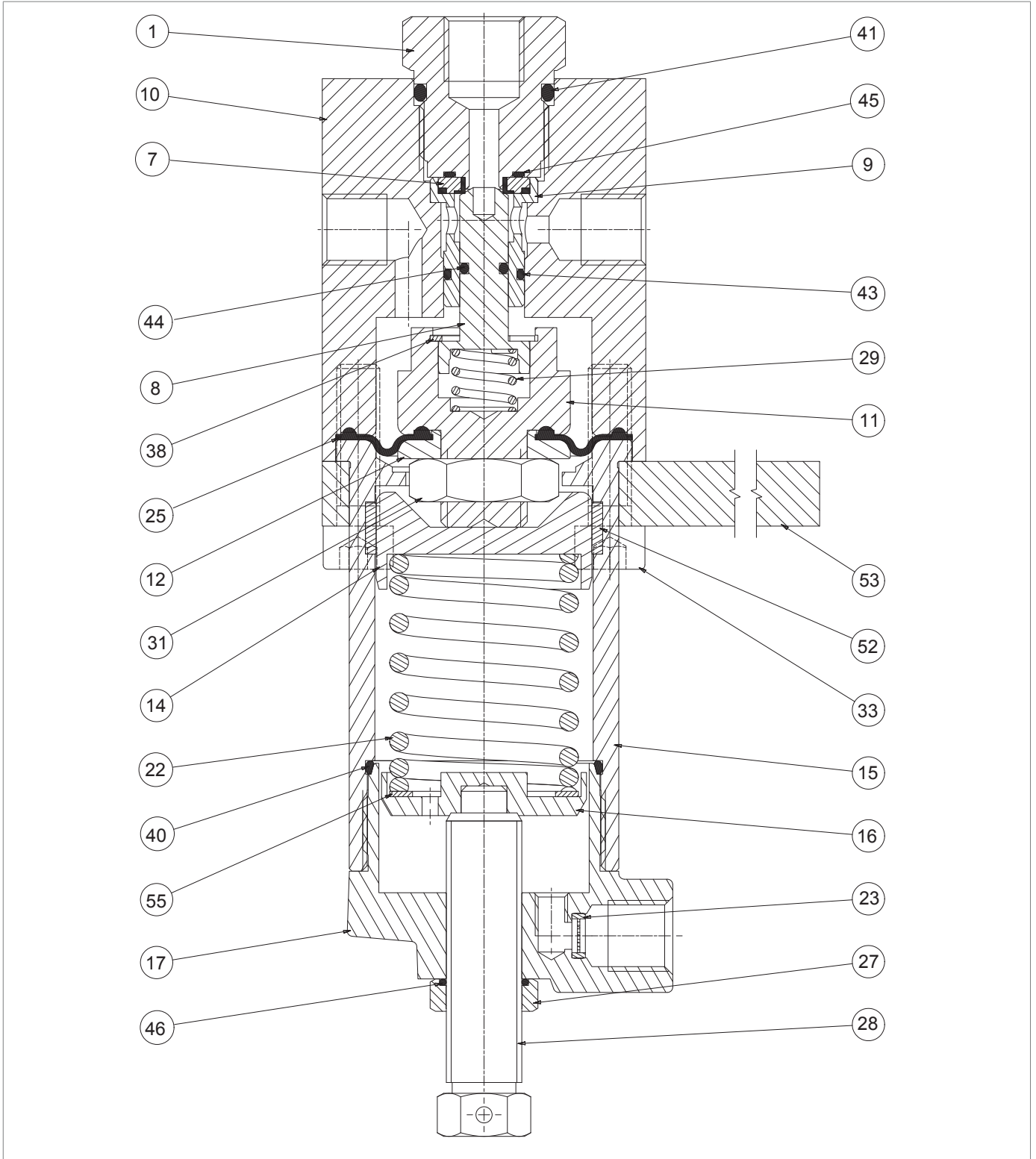





Fig. 9.69. M/A accelerating valve

Step	Action
1	Loosen the nut (27).
2	Completely release the spring (22) by turning the adjusting screw (28).
3	Remove the adjusting screw (28) together with the nut (27).
4	Remove the cap (17).
	Remove the O-ring (40) from the cap (17) and replace it, lubricating it with synthetic grease.
5	 <b>NOTICE!</b> <b>Before inserting the replacement O-ring, clean the retaining slots with a cleaning solution.</b>
6	Remove the lower spring support (16) together with the ring (55).
7	Remove the spring (22).
8	Remove the upper spring support (14).
9	Undo and remove the screws of the lower section (33).
10	Remove the bracket (53) from the sleeve (15).
11	Remove the sleeve (15).
	Remove and replace the I/DWR (52) from the sleeve (15).
12	 <b>NOTICE!</b> <b>Before inserting the replacement I/DWR, clean the retaining slots with a cleaning solution.</b>
13	Take out the diaphragm/plug unit (8,11,12, 25, 29, 31).
14	Unscrew and remove the nut (31).
15	Remove the diaphragm protection disc (12).
	Remove and replace the diaphragm (25).
16	 <b>NOTICE!</b> <b>Before inserting the replacement diaphragm, clean the retaining slots with a cleaning solution.</b>
17	Put the diaphragm protection disc (12) back in place.
18	Refit and secure the nut (31).
	Remove the O-ring (44) from the plug (8) and replace it, lubricating it with synthetic grease.
19	 <b>NOTICE!</b> <b>Before inserting the replacement O-ring, clean the retaining slots with a cleaning solution.</b>
20	Unscrew and remove the gasket support (1).
	Remove the O-rings (41, 45) from the gasket support (1) and replace them, lubricating them with synthetic grease.
21	 <b>NOTICE!</b> <b>Before inserting the replacement O-rings, clean the retaining slots with a cleaning solution.</b>
22	Take out the plug guide (9).
23	Remove and replace the reinforced gasket (7) from the plug guide (9).



*M/A accelerating valve*

Step	Action
24	Remove the O-ring (43) from the plug guide (9) and replace it, lubricating it with synthetic grease. <div style="border: 1px solid black; padding: 2px;">  <b>NOTICE!</b>  <b>Before inserting the replacement O-ring, clean the retaining slots with a cleaning solution.</b> </div>
25	Fit the plug guide (9) together with the reinforced gasket (7).
26	Place the gasket support (1) in the body (10).
27	Take out the diaphragm/plug unit (8, 11, 12, 25, 29, 31). <div style="border: 1px solid black; padding: 2px;">  <b>NOTICE!</b>  <b>Before inserting the diaphragm/plug unit, lubricate the plug (8) surface with silicone grease.</b> </div>
28	Fit the sleeve (15) and the bracket (53).
29	Insert and fix the screws (33). <div style="border: 1px solid black; padding: 2px;">  <b>NOTICE!</b>  <b>Tighten the screws as shown in the diagram at “9.4.2.2 - Cross diagram for tightening screws”.</b> </div>
30	Position the upper spring support (14) together with the spring (22).
31	Fit the lower spring support (16) together with the ring (55).
32	Fit and secure the cap (17).
33	Remove and replace the O-ring (46) in the nut (27). <div style="border: 1px solid black; padding: 2px;">  <b>NOTICE!</b>  <b>Before inserting the replacement O-ring, clean the retaining slots with a cleaning solution.</b> </div>
34	Fit the adjusting screw (28) together with the nut (27).

Tab. 9.138

 **WARNING!**

**Ensure that all parts have been fitted correctly.**

**9.4.9 - MAINTENANCE OF THE BUILT-IN SLAM SHUT VALVE SB/82**

**9.4.9.1 - SB/82 1" BUILT-IN SLAM-SHUT VALVE**

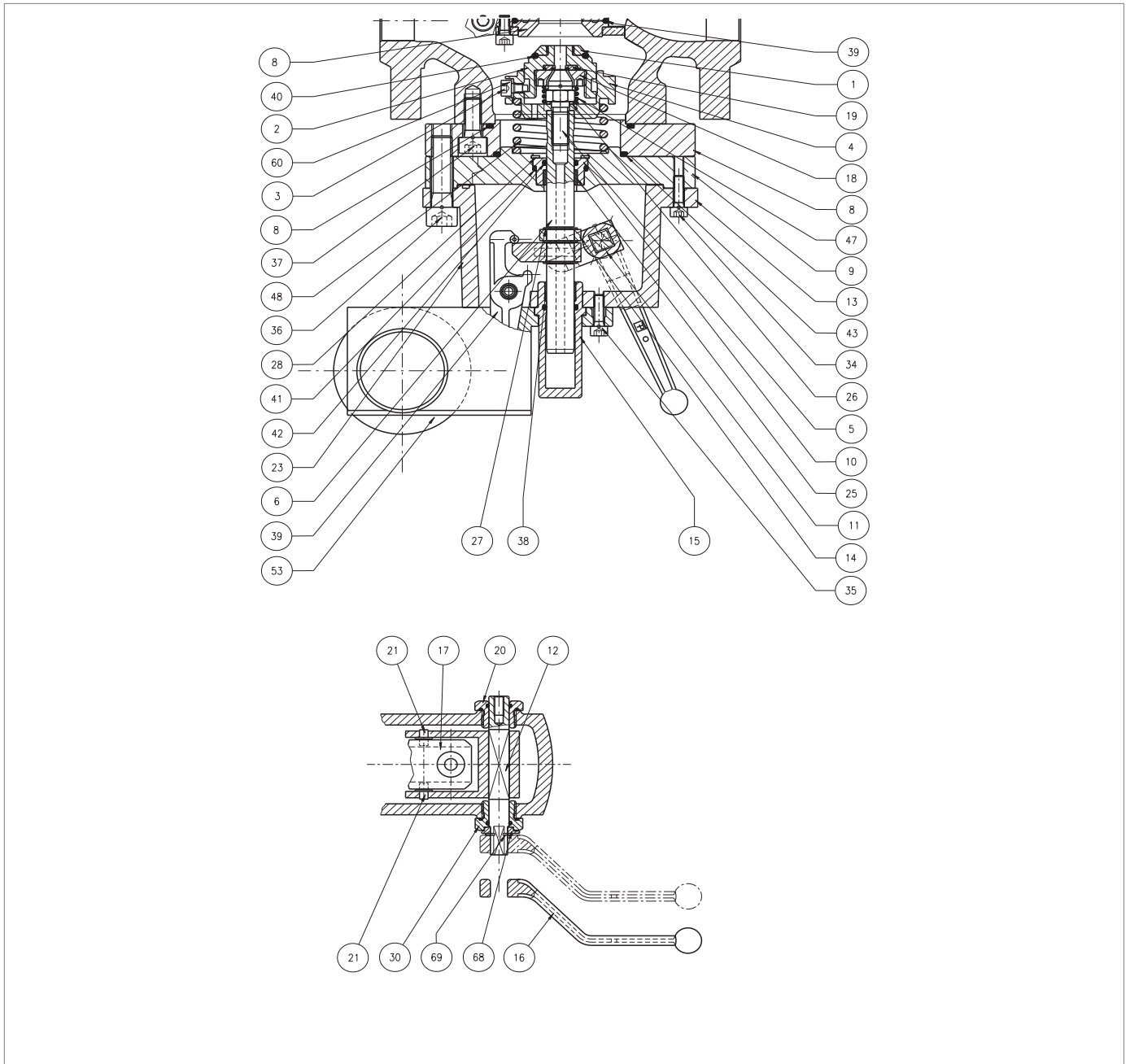







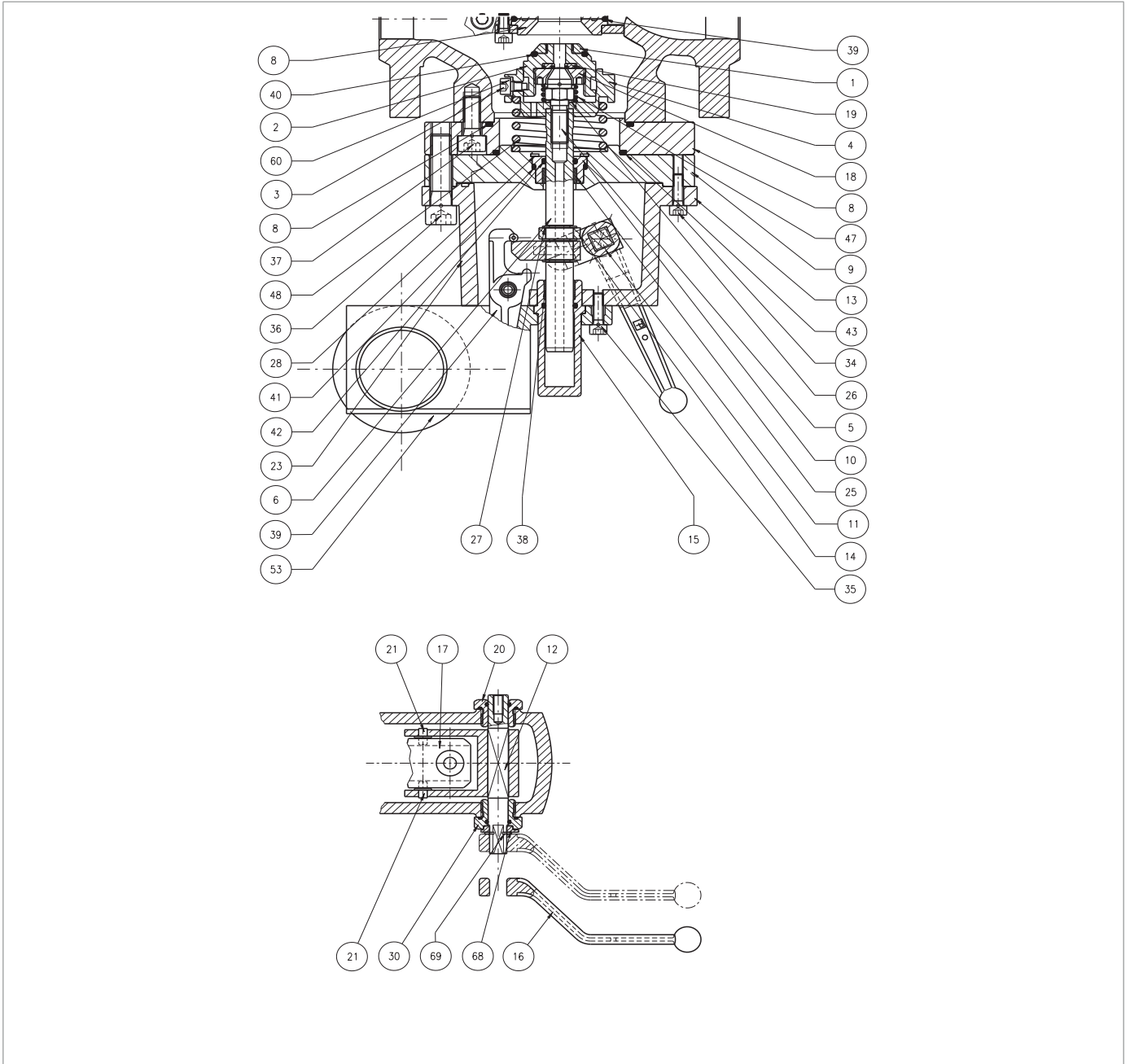

Fig. 9.70. SB/82 1" built-in slam-shut valve

Step	Action
1	 <b>WARNING!</b> <b>Check that the slam-shut valve is in the shut-off position.</b>
2	Undo and remove the screws (36).  <b>WARNING!</b> <b>Partially unscrew all screws before removing the first one to allow the spring to stretch.</b>
3	Remove the built-in SB/82 slam-shut valve and place it on an anti-shock surface.
4	Undo the screws (137).
5	Remove the flange (8).
6	Remove the O-ring (43) from the flange (8) and replace it, taking care to lubricate it with synthetic grease.  <b>NOTICE!</b> <b>Before inserting the replacement O-ring, clean the retaining slots with a cleaning solution.</b>
7	Remove the O-ring (37) from the flange (8) and replace it, taking care to lubricate it with synthetic grease.  <b>NOTICE!</b> <b>Before inserting the replacement O-ring, clean the retaining slots with a cleaning solution.</b>
8	Undo and remove the screws (3).
9	Undo and remove the toothed washers (60).
10	Take out the plug unit.
11	Remove the spring (47).
12	Unscrew and remove the ring nut (18) with the appropriate tool.  <b>NOTICE!</b> <b>Please refer to “Tab. 7.48” at “7.1 - List of equipment”.</b>
13	Remove and replace the pad (19).
14	Fit and fix the ring nut (18) with the appropriate tool.  <b>NOTICE!</b> <b>Please refer to “Tab. 7.48” at “7.1 - List of equipment”.</b>
15	Unscrew and remove the ring nut (1).
16	Remove the O-ring (40) from the plug (2) and replace it, taking care to lubricate it with synthetic grease.  <b>NOTICE!</b> <b>Before inserting the replacement O-ring, clean the retaining slots with a cleaning solution.</b>
17	Refit and secure the ring nut (1).
18	Undo the plug screw (5).
19	Remove the washer (26).
20	Remove the spring (48) and the spring support (4).
21	Undo and remove the screws (22) of the pressure switch.
22	Remove the cover (119) together with the gasket (29).
23	Undo the side screws (39) inside the box.



*SB/82 1" built-in slam-shut valve*

Step	Action
24	Undo the screws (35).
25	Take out the pressure switch unit. <b>NOTICE!</b> <b>For the maintenance procedure of the pressure switch unit, refer to the relative table.</b>
26	Remove the cup (15).
27	Remove the O-ring (42) from the cup (15) and replace it, taking care to lubricate it with synthetic grease. <b>NOTICE!</b> <b>Before inserting the replacement O-ring, clean the retaining slots with a cleaning solution.</b>
28	Undo and remove the screws (34).
29	Remove the intermediate body (13) from the flange (9).
30	Extract the stem (6) taking care not to damage it.
31	Remove the Seeger ring (28) from the flange (9).
32	Remove the bush (10).
33	Remove the O-ring (41) from the bush (10) and replace it, lubricating it with synthetic grease. <b>NOTICE!</b> <b>Before inserting the replacement O-ring, clean the retaining slots with a cleaning solution.</b>
34	Remove the I/DWR ring (25) from the bush (10) and replace it, taking care to lubricate it with synthetic grease. <b>NOTICE!</b> <b>Before inserting the replacement I/DWR ring, clean the retaining slots with a cleaning solution.</b>
35	Fit the bush (10). <b>NOTICE!</b> <b>Take care not to damage the O-ring (41).</b>
36	Fit the Seeger ring (28).
37	Fit the stem (6). <b>NOTICE!</b> <b>Lubricate the stem surface with silicone grease.</b>
38	Fit the intermediate body (13).
39	Fit the cup (15).
40	Fit the pressure switch unit.
41	Insert and fix the screws (35) according to the following tightening torque: <ul style="list-style-type: none"> <li>1" : "Tab. 9.99".</li> </ul>
42	Insert and fix the side screws (39) into the pressure switch according to the following tightening torque: <ul style="list-style-type: none"> <li>1" : "Tab. 9.99".</li> </ul>
43	Fit the gasket (29) and the cover (119).
44	Insert and fix the screws (22).
45	Put the spring (48) and spring support (4) in place.

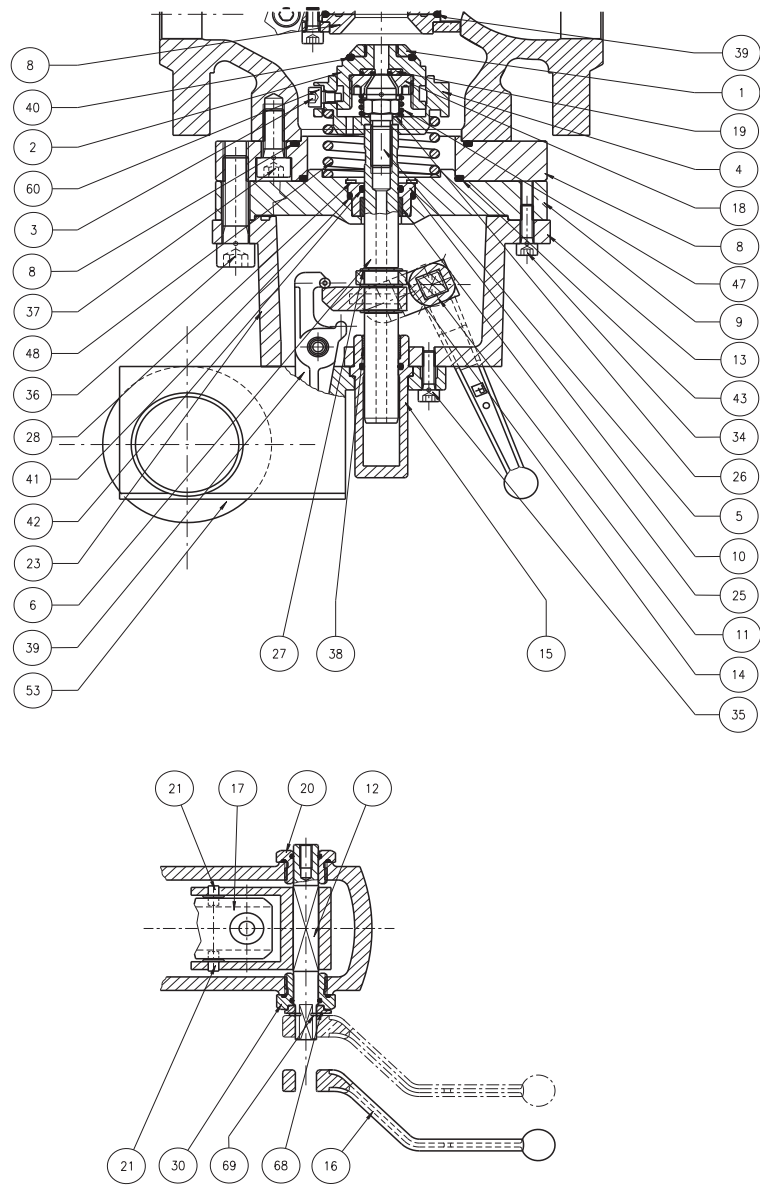

*SB/82 1" built-in slam-shut valve*

Step	Action
46	Fit the washer (26) <b>NOTICE!</b> <b>Before inserting the screw (5), apply thread locking glue.</b>
47	Fix the plug screw (5).
48	Fit the spring (47).
49	Fit the plug unit.
50	Insert the serrated washers (60). <b>NOTICE!</b> <b>Before inserting the screw (3), apply thread locking glue.</b>
51	Insert and fix the screws (3) according to the following tightening torque • 1" : "Tab. 9.99". <b>NOTICE!</b> <b>Tighten the screws as shown in the diagram at "9.4.2.2 - Cross diagram for tightening screws".</b>
52	Arm the slam-shut valve by moving the reset lever (16) to the opening position
53	Fit the flange (8) on the body.
54	Fix the screws (137) according to the following tightening torque • 1" : "Tab. 9.99". <b>NOTICE!</b> <b>Tighten the screws as shown in the diagram at "9.4.2.2 - Cross diagram for tightening screws".</b>
55	Put the SB/82 built-in slam-shut valve in place.
56	Insert and fix the screws (36) according to the following tightening torque • 1" : "Tab. 9.99". <b>NOTICE!</b> <b>Tighten the screws as shown in the diagram at "9.4.2.2 - Cross diagram for tightening screws".</b>

Tab. 9.139

**WARNING!**

**Ensure that all parts have been fitted correctly.**

9.4.9.2 - INCORPORATED SLAM-SHUT VALVE SB/82 2"- 3"

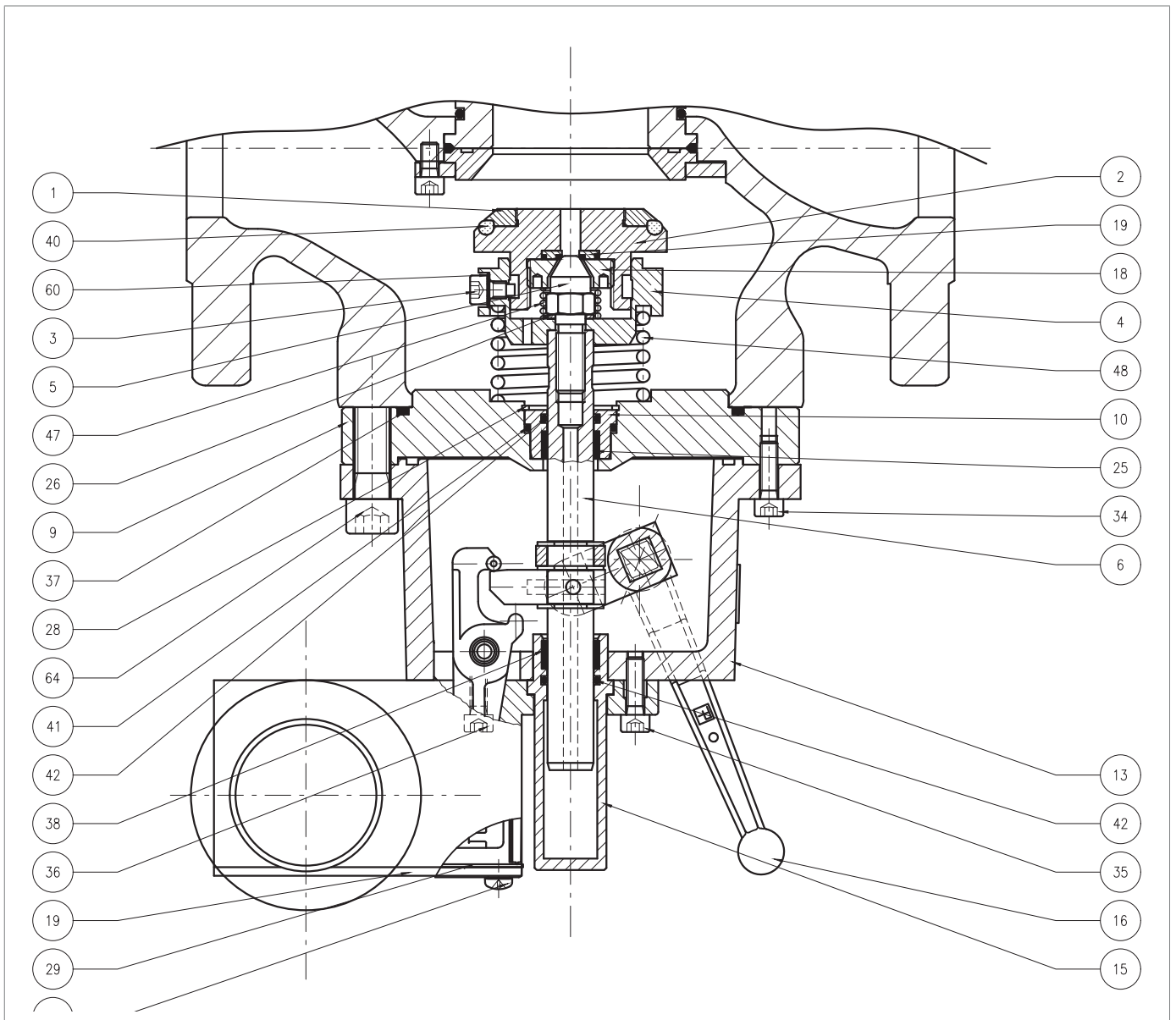







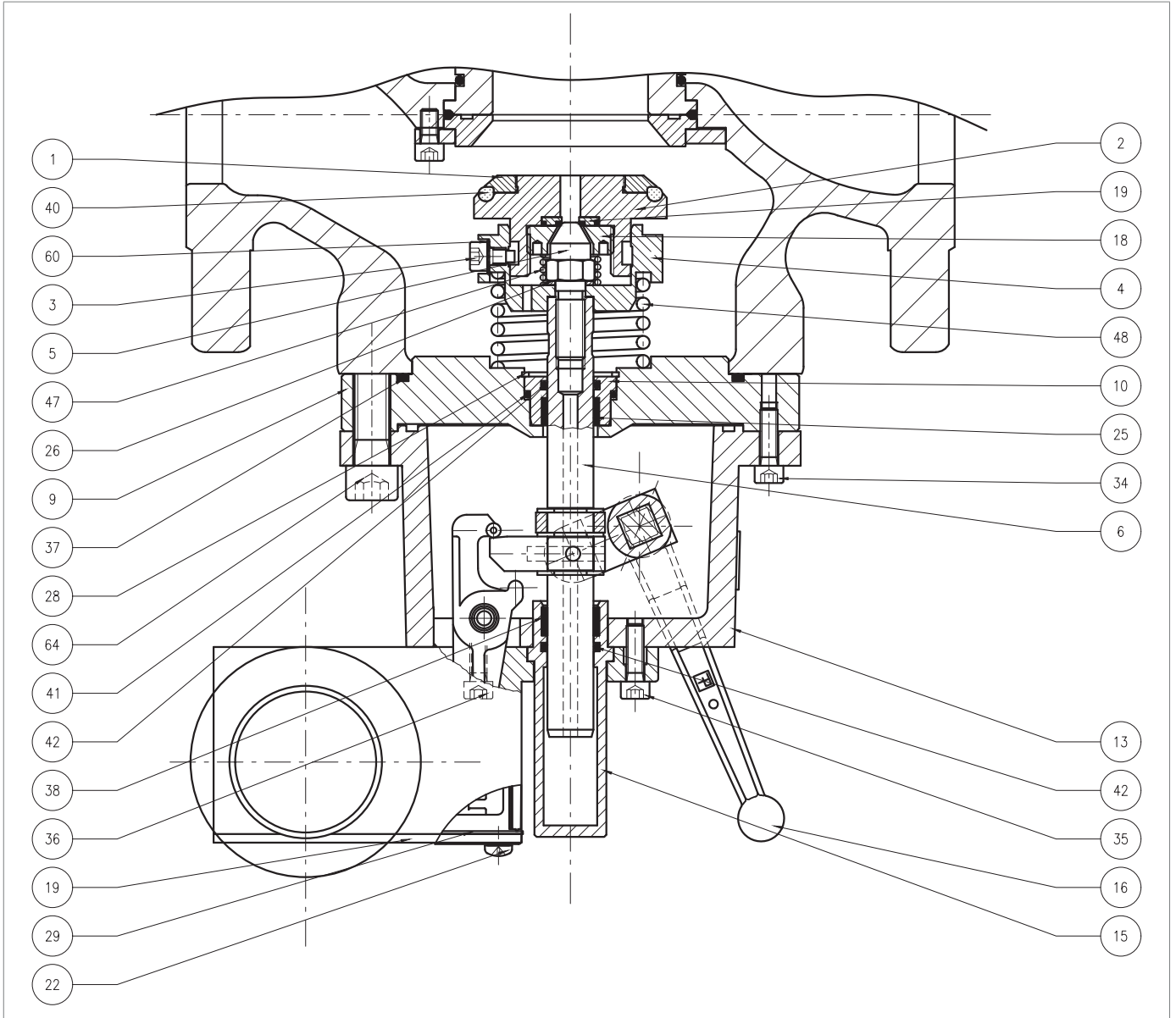

Fig. 9.71. Incorporated slam-shut valve SB/82 2"- 3"

Step	Action
1	 <b>WARNING!</b> <b>Check that the slam-shut valve is in the shut-off position.</b>
2	Undo and remove the screws (64).  <b>WARNING!</b> <b>Partially unscrew all screws before removing the first one to allow the spring to stretch.</b>
3	Remove the O-ring (37) from the flange (9) and replace it, taking care to lubricate it with synthetic grease.  <b>NOTICE!</b> <b>Before inserting the replacement O-ring, clean the retaining slots with a cleaning solution.</b>
4	Undo the screws (3) together with the toothed washers (60).
5	Take out the plug unit.
6	Remove the spring (47).
7	Unscrew and remove the ring nut (18) with the appropriate tool.  <b>NOTICE!</b> <b>Please refer to “Tab. 7.48” at “7.1 - List of equipment”.</b>
8	Remove and replace the pad (19).
9	Fit and fix the ring nut (18) with the appropriate tool.  <b>NOTICE!</b> <b>Please refer to “Tab. 7.48” at “7.1 - List of equipment”.</b>
10	Unscrew and remove the ring nut (1).
11	Remove the O-ring (40) from the plug (2) and replace it, taking care to lubricate it with synthetic grease.  <b>NOTICE!</b> <b>Before inserting the replacement O-ring, clean the retaining slots with a cleaning solution.</b>
12	Refit and secure the ring nut (1).
13	Undo the plug screw (5).
14	Remove the washer (26).
15	Remove the spring (48) and the spring support (4).
16	Undo and remove the screws (22) of the pressure switch.
17	Remove the cover (119) together with the gasket (29).
18	Undo the side screws (36) inside the control pressure switch.
19	Undo the external screws (35).
20	Take out the pressure switch unit.  <b>NOTICE!</b> <b>For the maintenance procedure of the pressure switch unit, refer to the relative table.</b>
21	Remove the cup (15).



*Incorporated slam-shut valve SB/82 2" - 3"*

Step	Action
22	<p>Remove the O-ring (42) from the cup (15) and replace it, taking care to lubricate it with synthetic grease.</p> <div style="border: 1px solid black; padding: 5px;"> <p><b>! NOTICE!</b>  <b>Before inserting the replacement O-ring, clean the retaining slots with a cleaning solution.</b></p> </div>
23	Undo and remove the screws (34).
24	Remove the intermediate body (13)
25	Extract the stem (6) taking care not to damage it.
26	Remove the Seeger ring (28) from the flange (9).
27	Remove the bush (10).
28	<p>Remove the O-ring (41) from the flange (9) and replace it, taking care to lubricate it with synthetic grease.</p> <div style="border: 1px solid black; padding: 5px;"> <p><b>! NOTICE!</b>  <b>Before inserting the replacement O-ring, clean the retaining slots with a cleaning solution.</b></p> </div>
29	<p>Remove the O-ring (42) from the bush (10) and replace it, lubricating it with synthetic grease.</p> <div style="border: 1px solid black; padding: 5px;"> <p><b>! NOTICE!</b>  <b>Before inserting the replacement O-ring, clean the retaining slots with a cleaning solution.</b></p> </div>
30	<p>Remove the I/DWR ring (25) from the bush (10) and replace it, taking care to lubricate it with synthetic grease.</p> <div style="border: 1px solid black; padding: 5px;"> <p><b>! NOTICE!</b>  <b>Before fitting the replacement I/DWR ring, clean the retaining slots using a cleaning solution.</b></p> </div>
31	Fit the valve seat (10), taking care not to damage the O-ring (41).
32	Place the Seeger ring (28) in the flange (9).
33	<p>Place the stem (6) in the bush (10).</p> <div style="border: 1px solid black; padding: 5px;"> <p><b>! NOTICE!</b>  <b>Lubricate the stem surface with silicone grease.</b></p> </div>
34	Fit the intermediate body (13).
35	Insert and fix the screws (34).
36	Fit the cup (15).
37	Fit the pressure switch unit.
38	<p>Insert and fix the screws (35) according to the following tightening torque:</p> <ul style="list-style-type: none"> <li>• 2" : "Tab. 9.100";</li> <li>• 3" : "Tab. 9.101".</li> </ul> <div style="border: 1px solid black; padding: 5px;"> <p><b>! NOTICE!</b>  <b>Tighten the screws as shown in the diagram at "9.4.2.2 - Cross diagram for tightening screws".</b></p> </div>
39	<p>Insert and fix the side screws (36) according to the following tightening torque:</p> <ul style="list-style-type: none"> <li>• 2" : "Tab. 9.100";</li> <li>• 3" : "Tab. 9.101".</li> </ul> <div style="border: 1px solid black; padding: 5px;"> <p><b>! NOTICE!</b>  <b>Tighten the screws as shown in the diagram at "9.4.2.2 - Cross diagram for tightening screws".</b></p> </div>
40	Fit the gasket (29) together with the cover (119).

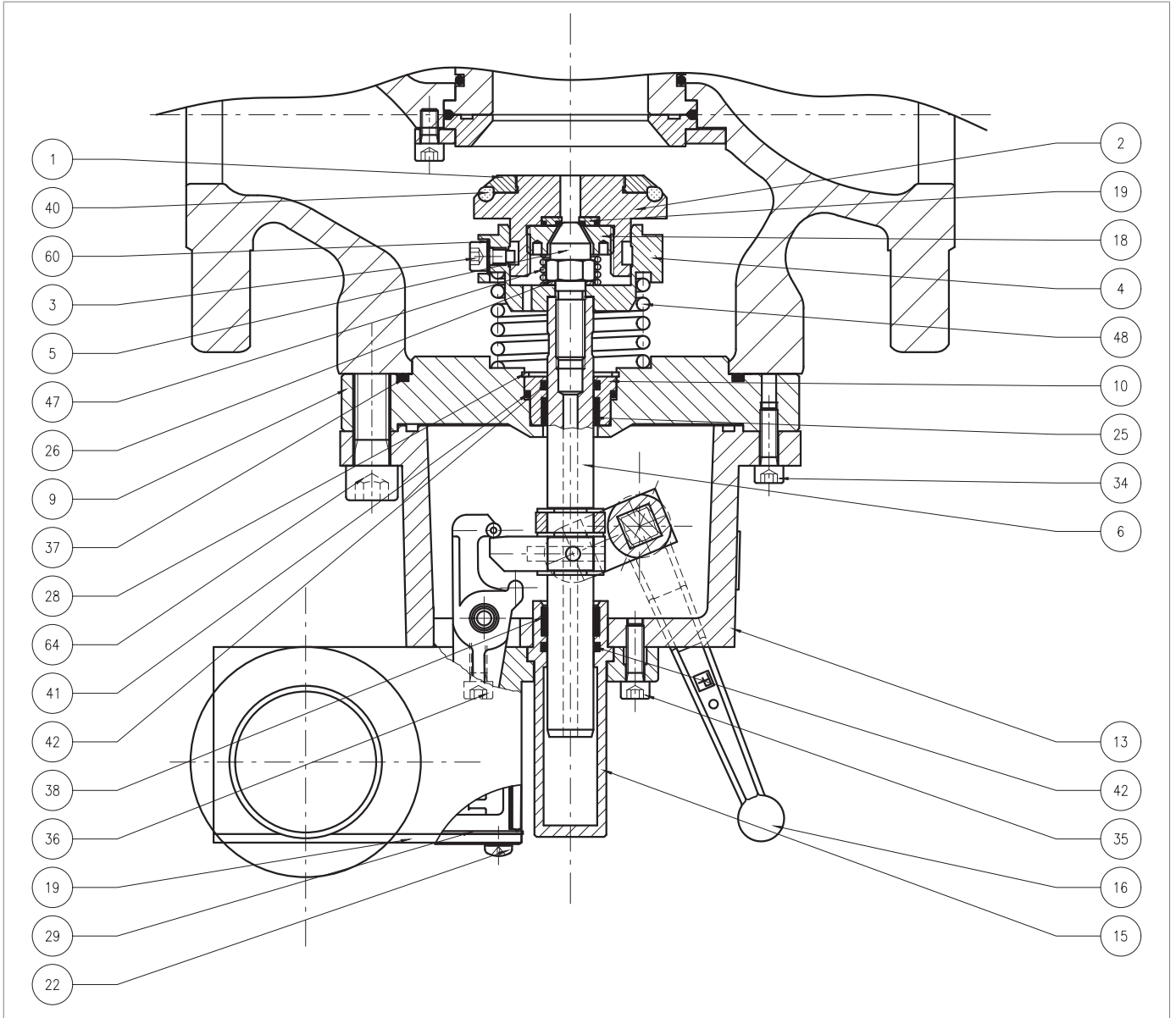

*Incorporated slam-shut valve SB/82 2" - 3"*

Step	Action
41	Insert and fix the screws (22).
42	Put the spring (48) and spring support (4) in place.
43	Fit the washer (26).
44	Insert and fix the plug screws (5) according to the following tightening torque: <ul style="list-style-type: none"> <li>• 2" : "Tab. 9.100";</li> <li>• 3" : "Tab. 9.101".</li> </ul> <div style="border: 1px solid black; padding: 5px;"> <p><b>! NOTICE!</b></p> <ul style="list-style-type: none"> <li>• <b>Before inserting the screw (5), apply thread locking glue;</b></li> <li>• <b>Tighten the screws as shown in the diagram at "9.4.2.2 - Cross diagram for tightening screws".</b></li> </ul> </div>
45	Fit the spring (47).
46	Fit the plug unit.
47	Insert the screws (3) together with the toothed washers (60). <div style="border: 1px solid black; padding: 5px;"> <p><b>! NOTICE!</b></p> <p><b>Before inserting the screw (3), apply thread locking glue.</b></p> </div>
48	Fasten the screws (3), holding down the plug unit to compress the spring (47) in the plug guide (4).
49	Arm the slam-shut valve by moving the reset lever (16) to the opening position
50	Put the SB/82 built-in slam-shut valve in place.
51	Insert and fix the screws (64) according to the following tightening torque: <ul style="list-style-type: none"> <li>• 2" : "Tab. 9.100";</li> <li>• 3" : "Tab. 9.101".</li> </ul> <div style="border: 1px solid black; padding: 5px;"> <p><b>! NOTICE!</b></p> <p><b>Tighten the screws as shown in the diagram at "9.4.2.2 - Cross diagram for tightening screws".</b></p> </div>

Tab. 9.140

**! WARNING!**

**Ensure that all parts have been fitted correctly.**

**9.4.9.3 - INCORPORATED SLAM-SHUT VALVE SB/82 4" - 8"**

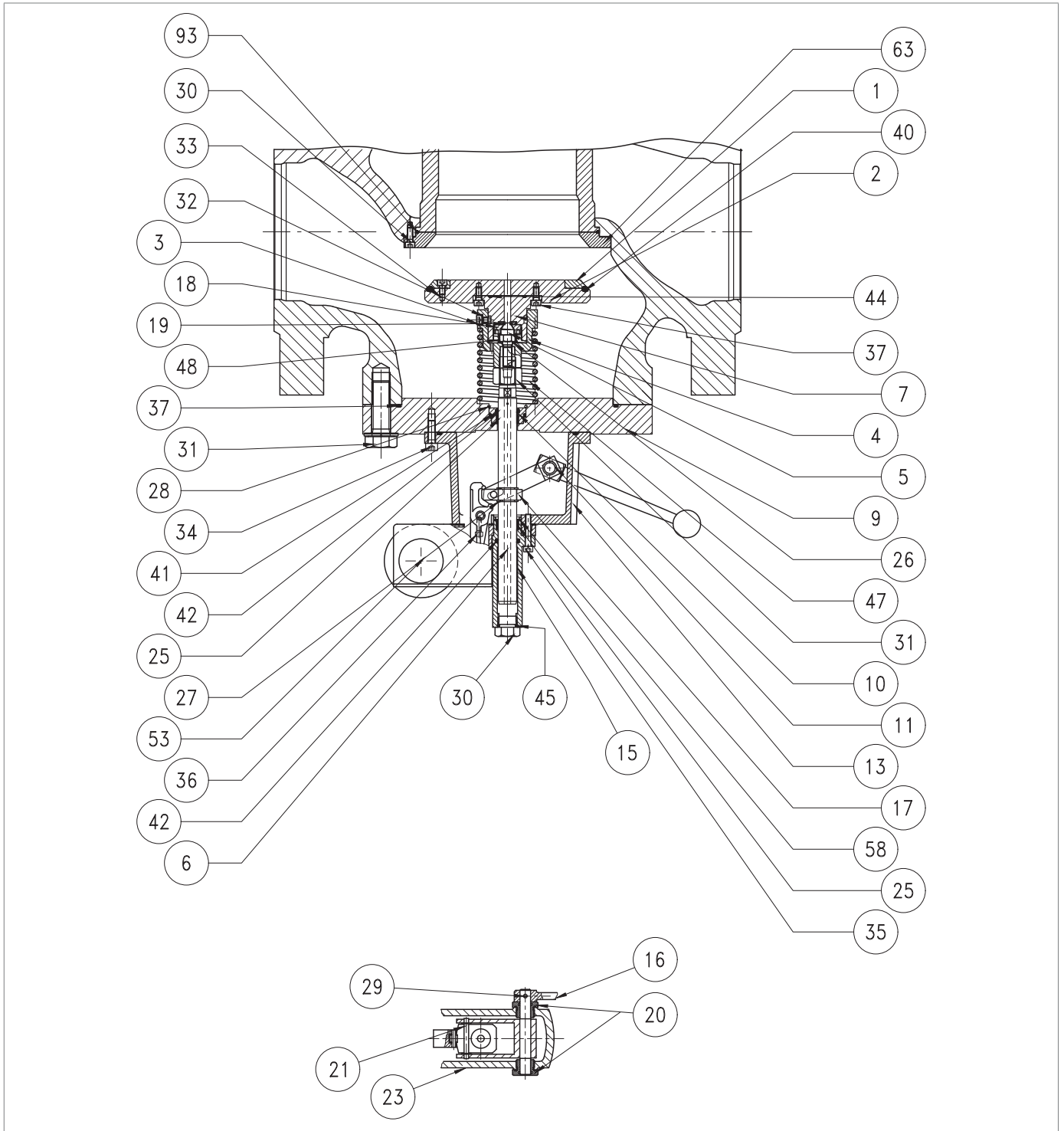







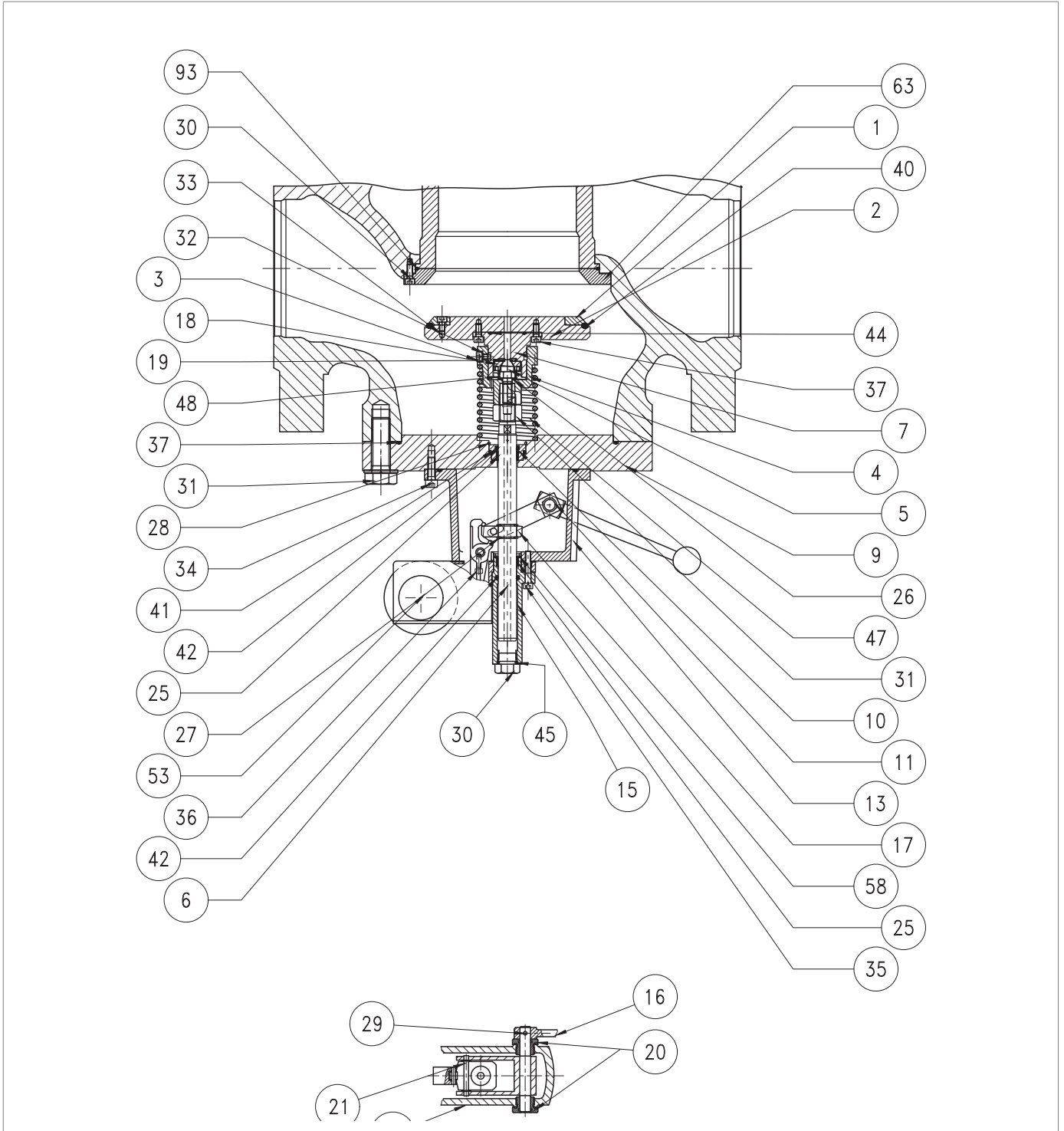







Fig. 9.72. Incorporated slam-shut valve SB/82 4" - 8"

Step	Action
1	 <b>WARNING!</b> <b>Check that the slam-shut valve is in the shut-off position.</b>
2	Undo and remove the screws (31).  <b>WARNING!</b> <b>Partially unscrew all screws before removing the first one to allow the spring to stretch.</b>
3	Remove the O-ring (37) from the flange (9) and replace it, taking care to lubricate it with synthetic grease.  <b>NOTICE!</b> <b>Before inserting the replacement O-ring, clean the retaining slots with a cleaning solution.</b>
4	Undo the screws (3) together with the toothed washers (32).
5	Take out the plug unit.
6	Remove the spring (47).
7	Unscrew and remove the ring nut (18) with an appropriate tool.  <b>NOTICE!</b> <b>Please refer to “Tab. 7.48” at “7.1 - List of equipment”.</b>
8	Remove and replace the pad (19).
9	Fit and fix the ring nut (18) with the appropriate tool.
10	Undo and remove the screws (137).
11	Remove the O-ring (44) from the plug support (7) and replace it, taking care to lubricate it with synthetic grease.  <b>NOTICE!</b> <b>Before inserting the replacement O-ring, clean the retaining slots with a cleaning solution.</b>
12	Undo the screws (33).
13	Remove the ring nut (1).
14	Remove the O-ring (40) from the plug (2) and replace it, taking care to lubricate it with synthetic grease.  <b>NOTICE!</b> <b>Before inserting the replacement O-ring, clean the retaining slots with a cleaning solution.</b>
15	Fit the ring nut (1).
16	Insert and fix the screws (33) according to the following tightening torques: <ul style="list-style-type: none"> <li>• 4” : “Tab. 9.102”;</li> <li>• 6” : “Tab. 9.103”;</li> <li>• 8” : “Tab. 9.104”.</li> </ul>  <b>NOTICE!</b> <b>Tighten the screws as shown in the diagram at “9.4.2.2 - Cross diagram for tightening screws”.</b>
17	Place the plug (2) on the plug support (7).



*Incorporated slam-shut valve SB/82 4''- 8''*

Step	Action
18	Insert and fix the screws (137) according to the following tightening torques: <ul style="list-style-type: none"> <li>• 4" : "Tab. 9.102";</li> <li>• 6" : "Tab. 9.103";</li> <li>• 8" : "Tab. 9.104".</li> </ul> <div style="border: 1px solid black; padding: 5px; margin-top: 10px;">  <b>NOTICE!</b>  <b>Tighten the screws as shown in the diagram at "9.4.2.2 - Cross diagram for tightening screws".</b> </div>
19	Undo the plug screw (5).
20	Remove the washer (26).
21	Remove the spring (48) and the spring support (4).
22	Unscrew and remove the nut (131).
23	Undo and remove the screws (22) of the pressure switch.
24	Remove the cover (119) and the gasket (29).
25	Undo the side screws (36) inside the control pressure switch.
26	Undo the screws (35).
27	Remove the cup (15).
28	Remove the O-ring (42) from the cup (15) and replace it, taking care to lubricate it with synthetic grease. <div style="border: 1px solid black; padding: 5px; margin-top: 10px;">  <b>NOTICE!</b>  <b>Before inserting the replacement O-ring, clean the retaining slots with a cleaning solution.</b> </div>
29	Remove the cap (30).
30	<b>VALID ONLY FOR 6"-8"</b> Remove the O-ring (45) from the cap (30) and replace it, taking care to lubricate it with synthetic grease. <div style="border: 1px solid black; padding: 5px; margin-top: 10px;">  <b>NOTICE!</b>  <b>Before inserting the replacement O-ring, clean the retaining slots with a cleaning solution.</b> </div>
31	Remove the Seeger ring (58) from the cup (15).
32	Remove the I/DWR ring (25) from the cup (15) and replace it, taking care to lubricate it with synthetic grease. <div style="border: 1px solid black; padding: 5px; margin-top: 10px;">  <b>NOTICE!</b>  <b>Before fitting the replacement I/DWR ring, clean the retaining slots using a cleaning solution.</b> </div>
33	Place the Seeger ring (58) in the cup (15).
34	Take out the pressure switch unit. <div style="border: 1px solid black; padding: 5px; margin-top: 10px;">  <b>NOTICE!</b>  <b>For the maintenance procedure of the pressure switch unit, refer to the relative table.</b> </div>
35	Undo and remove the screws (34).
36	Remove the intermediate body (13).
37	Remove the Seeger ring (28) from the flange (9).
38	Remove the bush (10).

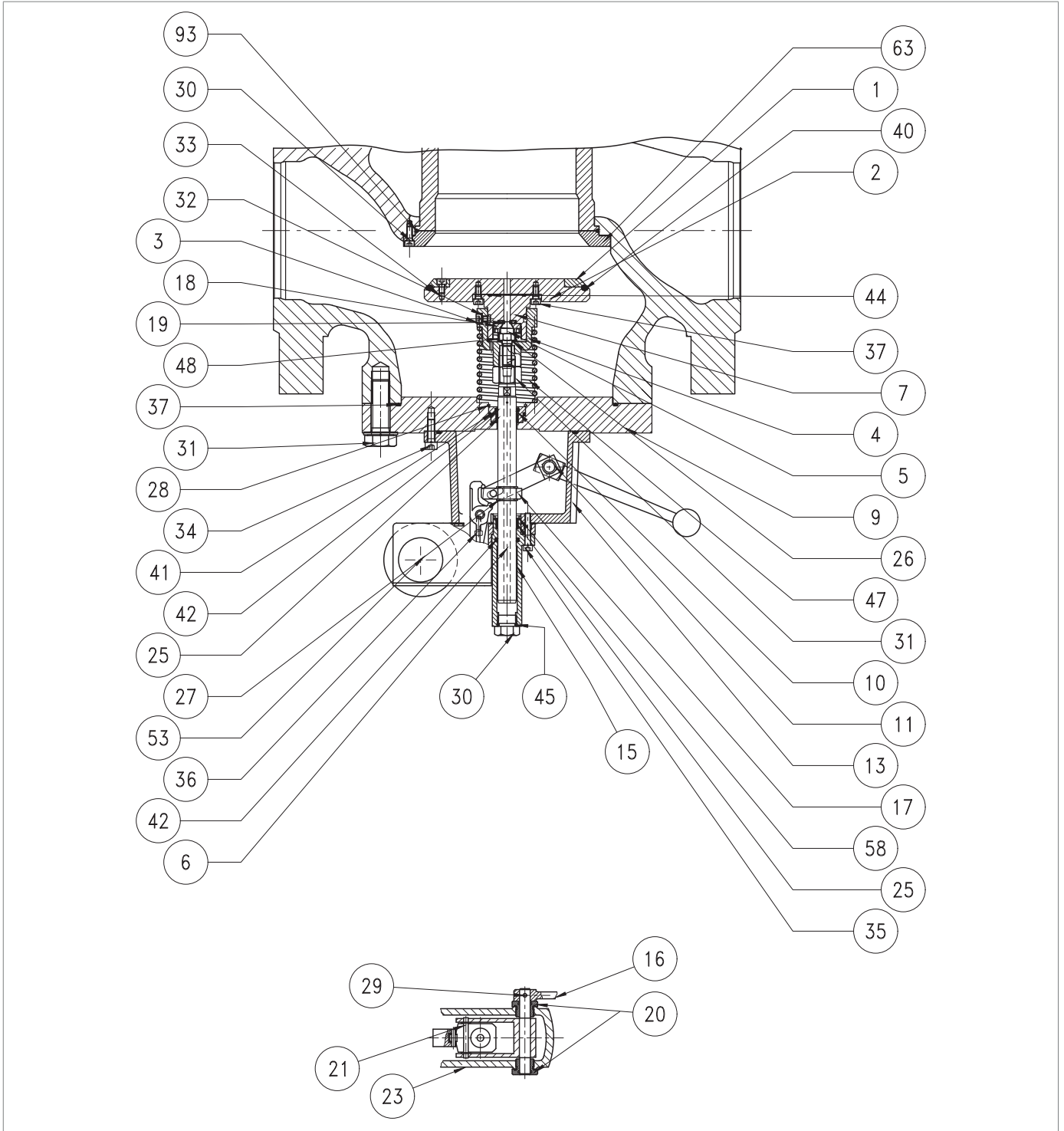



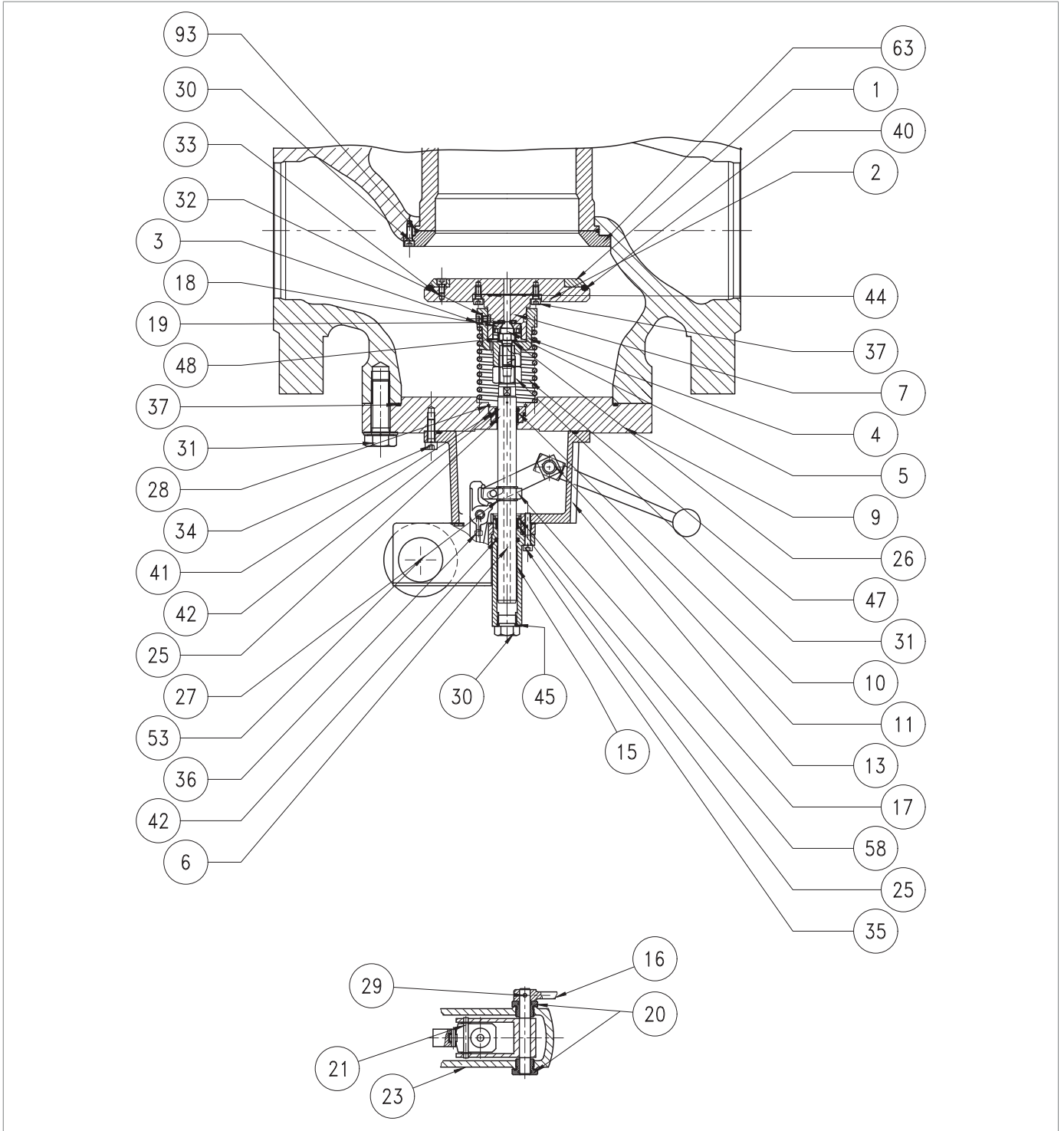

*Incorporated slam-shut valve SB/82 4"- 8"*

Step	Action
39	<p>Remove the O-ring (41) from the flange (9) and replace it, taking care to lubricate it with synthetic grease.</p> <p><b>NOTICE!</b> Before inserting the replacement O-ring, clean the retaining slots with a cleaning solution.</p>
40	<p>Remove the O-ring (42) from the bush (10) and replace it, lubricating it with synthetic grease.</p> <p><b>NOTICE!</b> Before inserting the replacement O-ring, clean the retaining slots with a cleaning solution.</p>
41	<p>Remove the I/DWR ring (25) from the bush (10) and replace it, taking care to lubricate it with synthetic grease.</p> <p><b>NOTICE!</b> Before fitting the replacement I/DWR ring, clean the retaining slots using a cleaning solution.</p>
42	Fit the valve seat (10), taking care not to damage the O-ring (41).
43	Place the Seeger ring (28) in the flange (9).
44	<p>Place the stem (6) in the bush (10).</p> <p><b>NOTICE!</b> Lubricate the stem surface with silicone grease.</p>
45	Fit the intermediate body (13).
46	<p>Insert and fix the screws (34) according to the following tightening torques:</p> <ul style="list-style-type: none"> <li>4" : "Tab. 9.102";</li> <li>6" : "Tab. 9.103";</li> <li>8" : "Tab. 9.104".</li> </ul> <p><b>NOTICE!</b> Tighten the screws as shown in the diagram at "9.4.2.2 - Cross diagram for tightening screws".</p>
47	Fit the pressure switch unit.
48	Fit the cup (15).
49	<p>Insert and fix the screws (35) according to the following tightening torques:</p> <ul style="list-style-type: none"> <li>4" : "Tab. 9.102";</li> <li>6" : "Tab. 9.103";</li> <li>8" : "Tab. 9.104".</li> </ul> <p><b>NOTICE!</b> Tighten the screws as shown in the diagram at "9.4.2.2 - Cross diagram for tightening screws".</p>
50	<p>Insert and fix the side screws (36) into the pressure switch according to the following tightening torques:</p> <ul style="list-style-type: none"> <li>4" : "Tab. 9.102";</li> <li>6" : "Tab. 9.103";</li> <li>8" : "Tab. 9.104".</li> </ul> <p><b>NOTICE!</b> Tighten the screws as shown in the diagram at "9.4.2.2 - Cross diagram for tightening screws".</p>
51	Fit and fix the cap (30).
52	Fit the gasket (29) and the cover (119).



*Incorporated slam-shut valve SB/82 4"- 8"*

Step	Action
53	Insert and fix the screws (22).  <b>NOTICE!</b> <b>Tighten the screws as shown in the diagram at “9.4.2.2 - Cross diagram for tightening screws”.</b>
54	Insert and fix the screws (131).
55	Put the spring (48) and spring support (4) in place.
56	Fit the washer (26).
57	Apply thread locking glue to insert and fix the plug screws (5) according to the following tightening torque: <ul style="list-style-type: none"> <li>• 4” : “Tab. 9.102”;</li> <li>• 6” : “Tab. 9.103”;</li> <li>• 8” : “Tab. 9.104”.</li> </ul>  <b>NOTICE!</b> <b>Tighten the screws as shown in the diagram at “9.4.2.2 - Cross diagram for tightening screws”.</b>
58	Fit the spring (47).
59	Fit the plug unit.
60	Insert the screws (3) together with the toothed washers (60).  <b>NOTICE!</b> <b>Before inserting the screw (3), apply thread locking glue.</b>
61	Fasten the screws (3), holding down the plug unit to compress the spring (47) in the plug guide (4).
62	Arm the slam-shut valve by moving the reset lever (16) to the opening position
63	Put the SB/82 built-in slam-shut valve in place.
64	Insert and fix the screws (31) according to the following tightening torque: <ul style="list-style-type: none"> <li>• 4” : “Tab. 9.102”;</li> <li>• 6” : “Tab. 9.103”;</li> <li>• 8” : “Tab. 9.104”.</li> </ul>  <b>NOTICE!</b> <b>Tighten the screws as shown in the diagram at “9.4.2.2 - Cross diagram for tightening screws”.</b>

Tab. 9.141

 **WARNING!**

**Ensure that all parts have been fitted correctly.**

**9.4.9.4 - BUILT-IN SLAM-SHUT VALVE SB/82 10"**

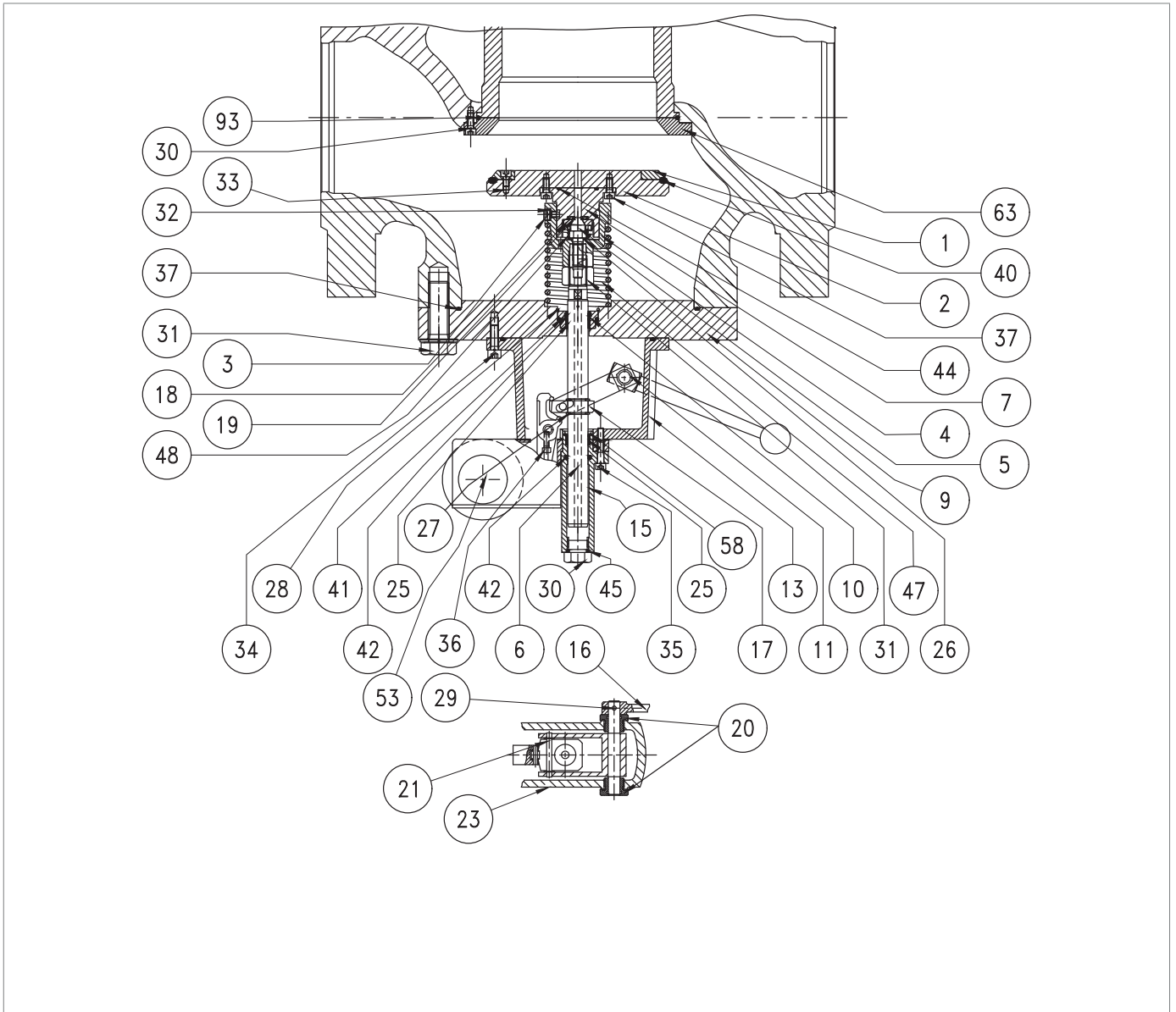





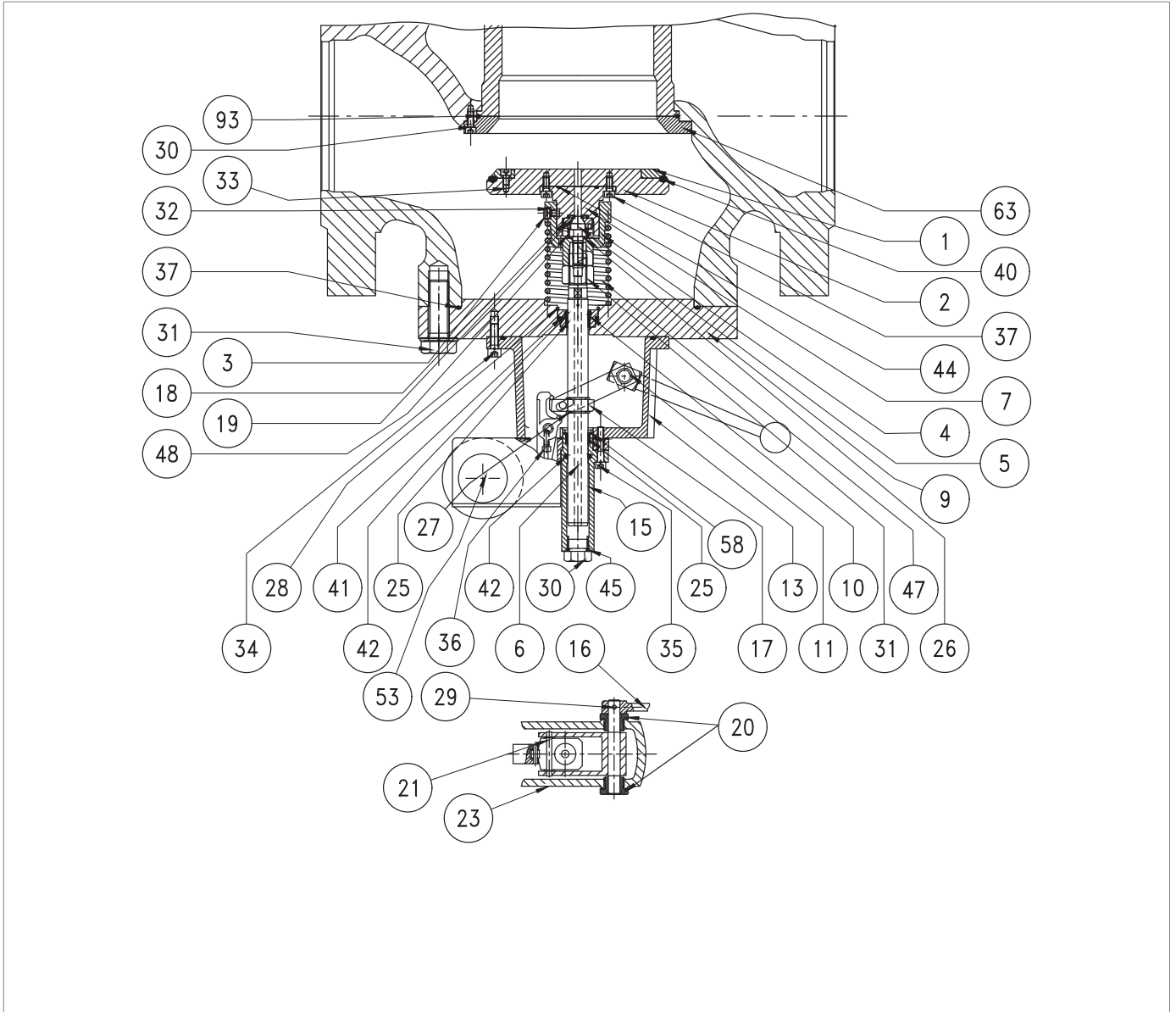

Fig. 9.73. Built-in slam-shut valve SB/82 10"

Step	Action
1	 <b>WARNING!</b> <b>Check that the slam-shut valve is in the shut-off position.</b>
2	Undo and remove the screws (31).  <b>WARNING!</b> <b>Partially unscrew all screws before removing the first one to allow the spring to stretch.</b>
3	Remove the SB/82 built-in slam-shut valve and place it on a shock-proof surface.
4	Remove the O-ring (37) from the flange (9) and replace it, taking care to lubricate it with synthetic grease.  <b>NOTICE!</b> <b>Before inserting the replacement O-ring, clean the retaining slots with a cleaning solution.</b>
5	Unscrew and remove the nuts (131) together with the washer (32).
6	Remove the plug (2) together with the plug sleeve (1) and the bush (5).
7	Remove the bush (5).
8	Remove the O-ring (42) from the bush (5) and replace it, lubricating it with synthetic grease.  <b>NOTICE!</b> <b>Before inserting the replacement O-ring, clean the retaining slots with a cleaning solution.</b>
9	Undo and remove the screws (33).
10	Separate the plug (2) from the plug sleeve (1).
11	Remove the I/DWR rings (24) from the plug sleeve (1) and replace them, lubricating them with synthetic grease.  <b>NOTICE!</b> <b>Before fitting the replacement I/DWR ring, clean the retaining slots using a cleaning solution.</b>
12	Unscrew and remove the extension (3) from the stem (6).
13	Remove the spring (48) and the spring support (4).
14	Undo and remove the screws (22) of the pressure switch.
15	Remove the cover (19) and the gasket (29).
16	Undo the side screws (137) inside the control pressure switch.
17	Undo the screws (36).
18	Remove the cup (15).
19	Remove the O-ring (42) from the cup (15) and replace it, taking care to lubricate it with synthetic grease.  <b>NOTICE!</b> <b>Before inserting the replacement O-ring, clean the retaining slots with a cleaning solution.</b>
20	Remove the cap (30).
21	Remove the O-ring (45) from the cap (30) and replace it, taking care to lubricate it with synthetic grease.  <b>NOTICE!</b> <b>Before inserting the replacement O-ring, clean the retaining slots with a cleaning solution.</b>





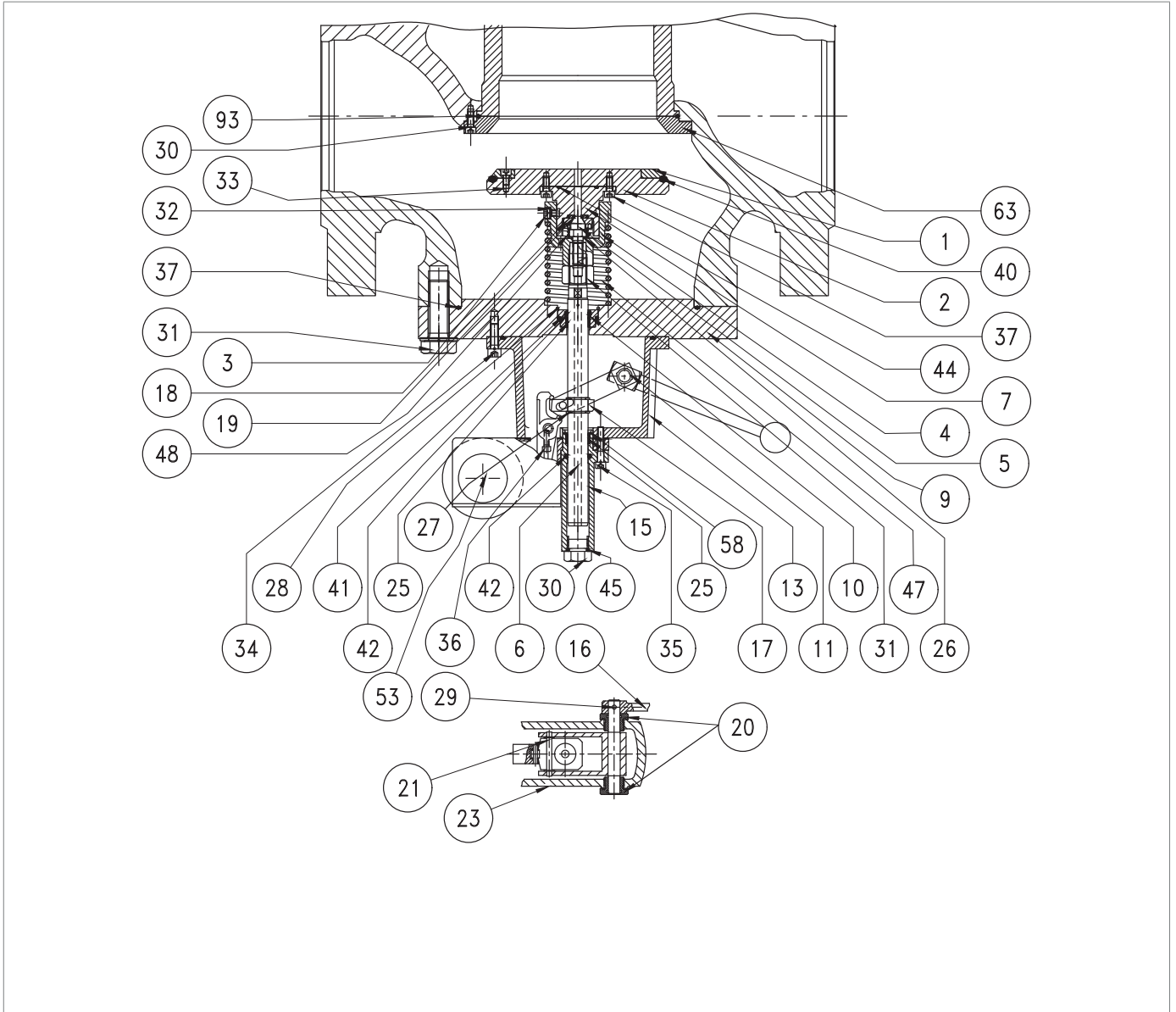

*Built-in slam-shut valve SB/82 10"*

Step	Action
22	Remove the Seeger ring (58) from the cup (15).
23	Remove the I/DWR ring (25) from the cup (15) and replace it, taking care to lubricate it with synthetic grease. <b>NOTICE!</b> <b>Before fitting the replacement I/DWR ring, clean the retaining slots using a cleaning solution.</b>
24	Place the Seeger ring (58) in the cup (15).
25	Take out the pressure switch unit. <b>NOTICE!</b> <b>For the maintenance procedure of the pressure switch unit, refer to the relative table.</b>
26	Undo and remove the screws (35).
27	Remove the intermediate body (13).
28	Remove the stem (6) taking care not to damage it.
29	Remove the Seeger ring (28) from the flange (9).
30	Remove the bush (10).
31	Remove the O-ring (41) from the flange (9) and replace it, taking care to lubricate it with synthetic grease. <b>NOTICE!</b> <b>Before inserting the replacement O-ring, clean the retaining slots with a cleaning solution.</b>
32	Remove the O-ring (42) from the bush (10) and replace it, lubricating it with synthetic grease. <b>NOTICE!</b> <b>Before inserting the replacement O-ring, clean the retaining slots with a cleaning solution.</b>
33	Fit the valve seat (10), taking care not to damage the O-ring (41).
34	Place the Seeger ring (28) in the flange (9).
35	Place the stem (6) in the bush (10). <b>NOTICE!</b> <b>Lubricate the stem surface with silicone grease.</b>
36	Fit the intermediate body (13).
37	Fit the pressure switch unit.
38	Insert and fix the screws (35) according to the following tightening torque: • 10" : "Tab. 9.105". <b>NOTICE!</b> <b>Tighten the screws as shown in the diagram at "9.4.2.2 - Cross diagram for tightening screws".</b>
39	Fit the cup (15).
40	Insert and fix the side screws (137) into the pressure switch according to the following tightening torque: • 10" : "Tab. 9.105". <b>NOTICE!</b> <b>Tighten the screws as shown in the diagram at "9.4.2.2 - Cross diagram for tightening screws".</b>



*Built-in slam-shut valve SB/82 10"*

Step	Action
41	Insert and fix the screws (36) according to the following tightening torque: <ul style="list-style-type: none"> <li>10" : "Tab. 9.105".</li> </ul> <div style="border: 1px solid blue; padding: 5px;">  <b>NOTICE!</b>  <b>Tighten the screws as shown in the diagram at "9.4.2.2 - Cross diagram for tightening screws".</b> </div>
42	Fit and secure the cap (30).
43	Fit the gasket (29) and the cover (19).
44	Insert and fix the screws (22).
45	Place the plug sleeve (1) on the plug (2) and
46	Insert and fix the screws (33) according to the following tightening torque: <ul style="list-style-type: none"> <li>10" : "Tab. 9.105".</li> </ul> <div style="border: 1px solid blue; padding: 5px;">  <b>NOTICE!</b>  <b>Tighten the screws as shown in the diagram at "9.4.2.2 - Cross diagram for tightening screws".</b> </div>
47	Fit the bush (5) in the plug (2).
48	Put the spring (48) and spring support (4) in place.
49	Position and screw the extension (3).
50	Fit the plug (2) together with the plug sleeve (1).
51	Position and secure the nuts (31), together with the washer (32).
52	<div style="background-color: orange; padding: 5px;">  <b>WARNING!</b>  <b>During the next steps, support the SB/82 slam-shut valve so as to prevent any falls.</b> </div>
53	Put the SB/82 built-in slam-shut valve in place.
54	Insert and fix the screws (31) according to the following tightening torque: <ul style="list-style-type: none"> <li>10" : "Tab. 9.105".</li> </ul> <div style="border: 1px solid blue; padding: 5px;">  <b>NOTICE!</b>  <b>Tighten the screws as shown in the diagram at "9.4.2.2 - Cross diagram for tightening screws".</b> </div>

Tab. 9.142

 **WARNING!**

**Ensure that all parts have been fitted correctly.**

#### 9.4.10 - HP2/2 BYPASS DEVICE MAINTENANCE PROCEDURE

 **NOTICE!**

**For further information refer to the relevant table.**

**9.4.11 - MAINTENANCE PROCEDURE FOR PRESSURE SWITCHES MODELS 102M/102MH - 105M/105MH**

**9.4.11.1 - PRESSURE SWITCH MOD. 102M/102MH**

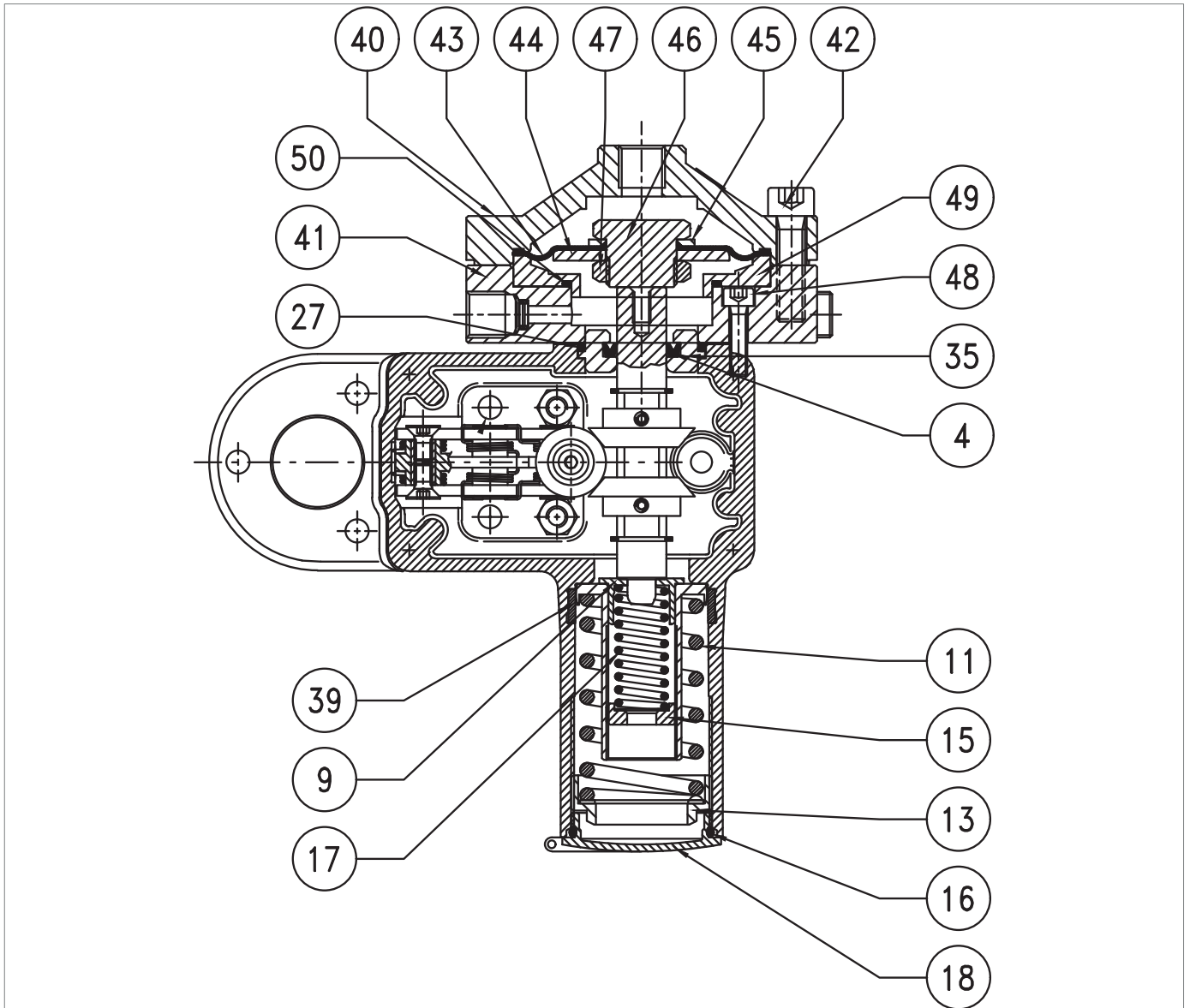
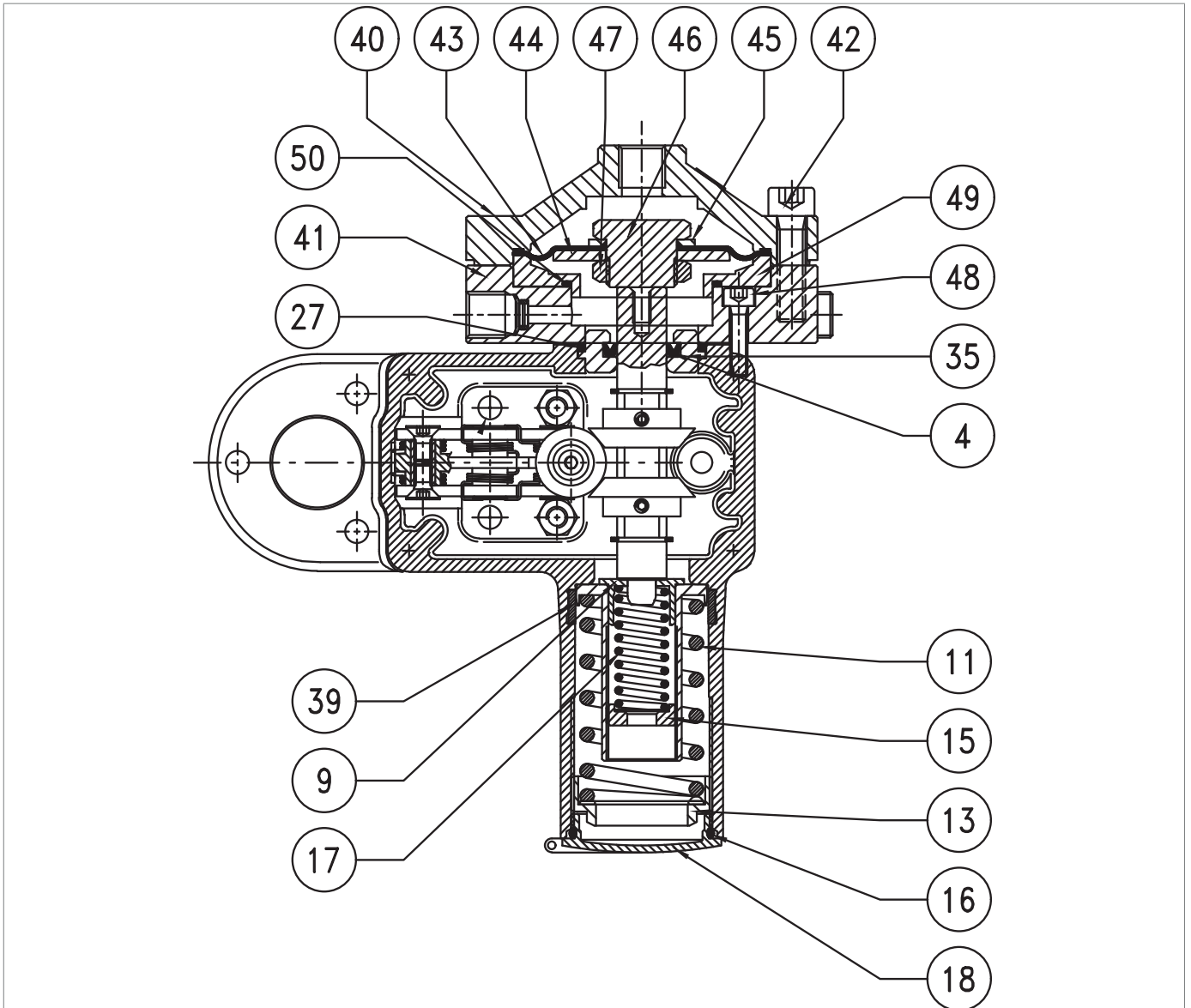

Fig. 9.74. Pressure switch Mod. 102M/102MH

Step	Action
1	Unscrew and remove the cap (18).
2	Remove the O-ring (16) from the cover (18) and replace it, lubricating it with synthetic grease. <b>NOTICE!</b> <b>Before inserting the replacement O-ring, clean the retaining slots with a cleaning solution.</b>
3	Completely release the spring (11) by adjusting the ring nut (13).
4	Completely release the minimum pressure spring (17) by adjusting the ring nut (15). <b>NOTICE!</b> <b>The minimum spring may not be installed.</b>
5	Remove the ring nut (13), the spring (11) and the spring support (17).
6	Remove the I/DWR ring (39) from the pressure switch sleeve and replace it, lubricating it with synthetic grease. <b>NOTICE!</b> <b>Before inserting the replacement I/DWR ring, clean the retaining slots with a cleaning solution.</b>
7	Undo and remove the screws (42).
8	Remove the upper cover (40).
9	Take out the diaphragm unit (43, 44, 45, 46, 47).
10	Unscrew the nut (47).
11	Remove the diaphragm protection disc (44).
12	Remove and replace the diaphragm (43), lubricating the lanyard with synthetic grease. <b>NOTICE!</b> <b>Before inserting the replacement diaphragm, clean the retaining slots with a cleaning solution.</b>
13	Fit the diaphragm protection disc (44).
14	Place and fix the nut (47) according to the following tightening torque: <ul style="list-style-type: none"> <li>• Mod. 102: "Tab. 9.106"</li> </ul>
15	Remove the ring (49).
16	Undo and remove the screws (48).
17	Remove the lower lid (41).
18	Remove the O-ring (50) from the nut (49) and replace it, lubricating it with synthetic grease. <b>NOTICE!</b> <b>Before inserting the replacement O-ring, clean the retaining slots with a cleaning solution.</b>
19	Remove the bush (35).
20	Remove the O-ring (27) from the bush (35) and replace it, lubricating it with synthetic grease. <b>NOTICE!</b> <b>Before inserting the replacement O-ring, clean the retaining slots with a cleaning solution.</b>



Pressure switch Mod. 102M/102MH

Step	Action
21	<p>Remove the U-shaped ring (4) from the bush (35) and replace it, lubricating it with synthetic grease.</p> <p><b>! NOTICE!</b> <b>Before inserting the replacement U-ring, clean the retaining slots with a cleaning solution.</b></p>
22	<p>Position the bush (35) together with the O-ring (27).</p> <p><b>! NOTICE!</b> <b>Before inserting the bush (35), lubricate the inner surface with silicone grease.</b></p>
23	<p>Fit the lower cover (41).</p> <p><b>! NOTICE!</b> <b>Make sure there is a gasket between the lower cover and the pressure switch body.</b></p>
24	<p>Insert and fix the screws (48) according to the following tightening torque:</p> <ul style="list-style-type: none"> <li>• Mod. 102: "Tab. 9.106".</li> </ul> <p><b>! NOTICE!</b> <b>Tighten the screws as shown in the diagram at "9.4.2.2 - Cross diagram for tightening screws".</b></p>
25	Put the diaphragm unit in place (43, 44, 45, 46, 47).
26	Fit the lid (40).
27	<p>Insert and fix the screws (42) according to the following tightening torque:</p> <ul style="list-style-type: none"> <li>• Mod. 102: "Tab. 9.106".</li> </ul> <p><b>! NOTICE!</b> <b>Tighten the screws as shown in the diagram at "9.4.2.2 - Cross diagram for tightening screws".</b></p>

Tab. 9.143

**! WARNING!**

**Ensure that all parts have been fitted correctly.**

9.4.11.2 - PRESSURE SWITCH MOD. 103M/103MH

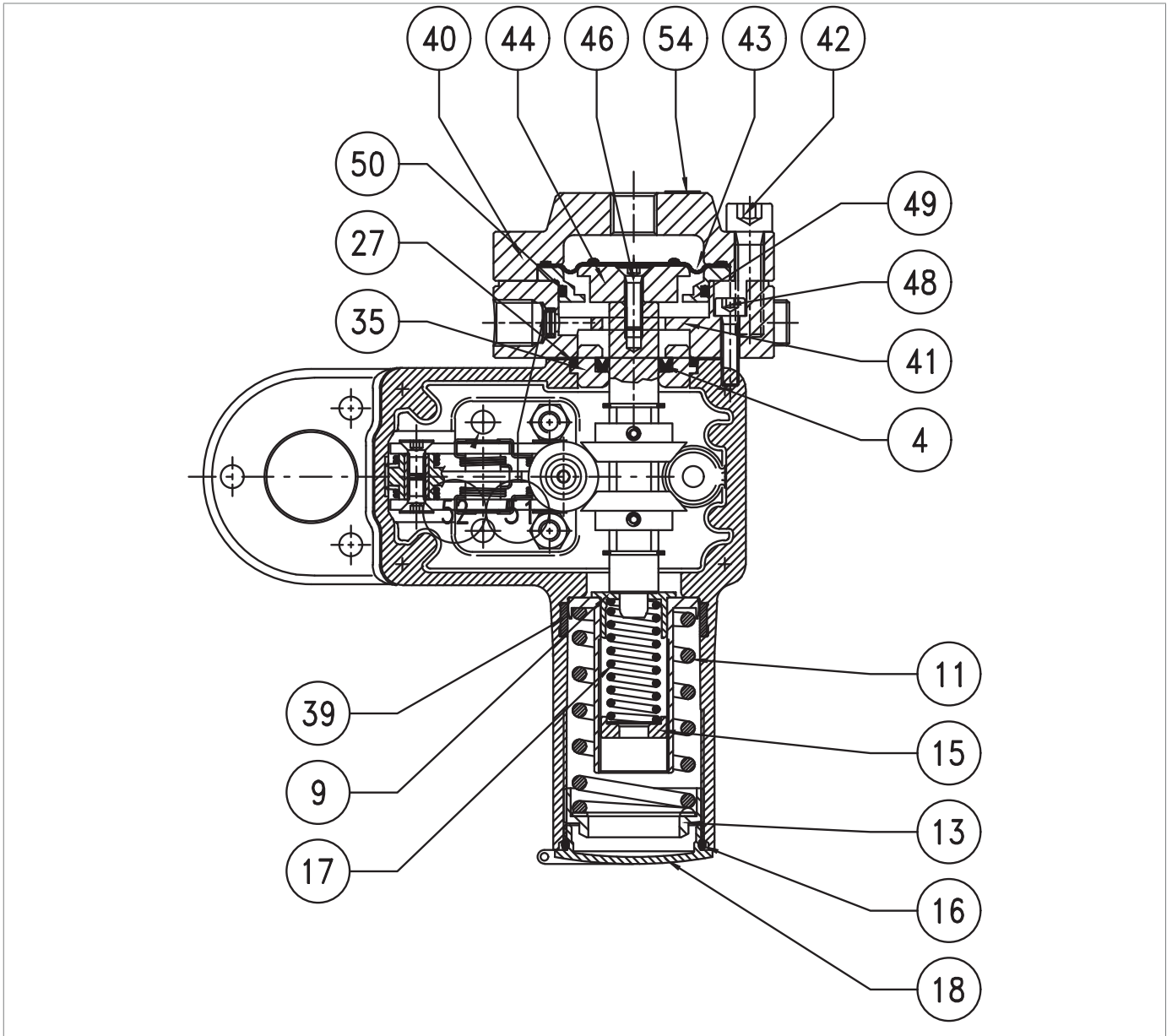
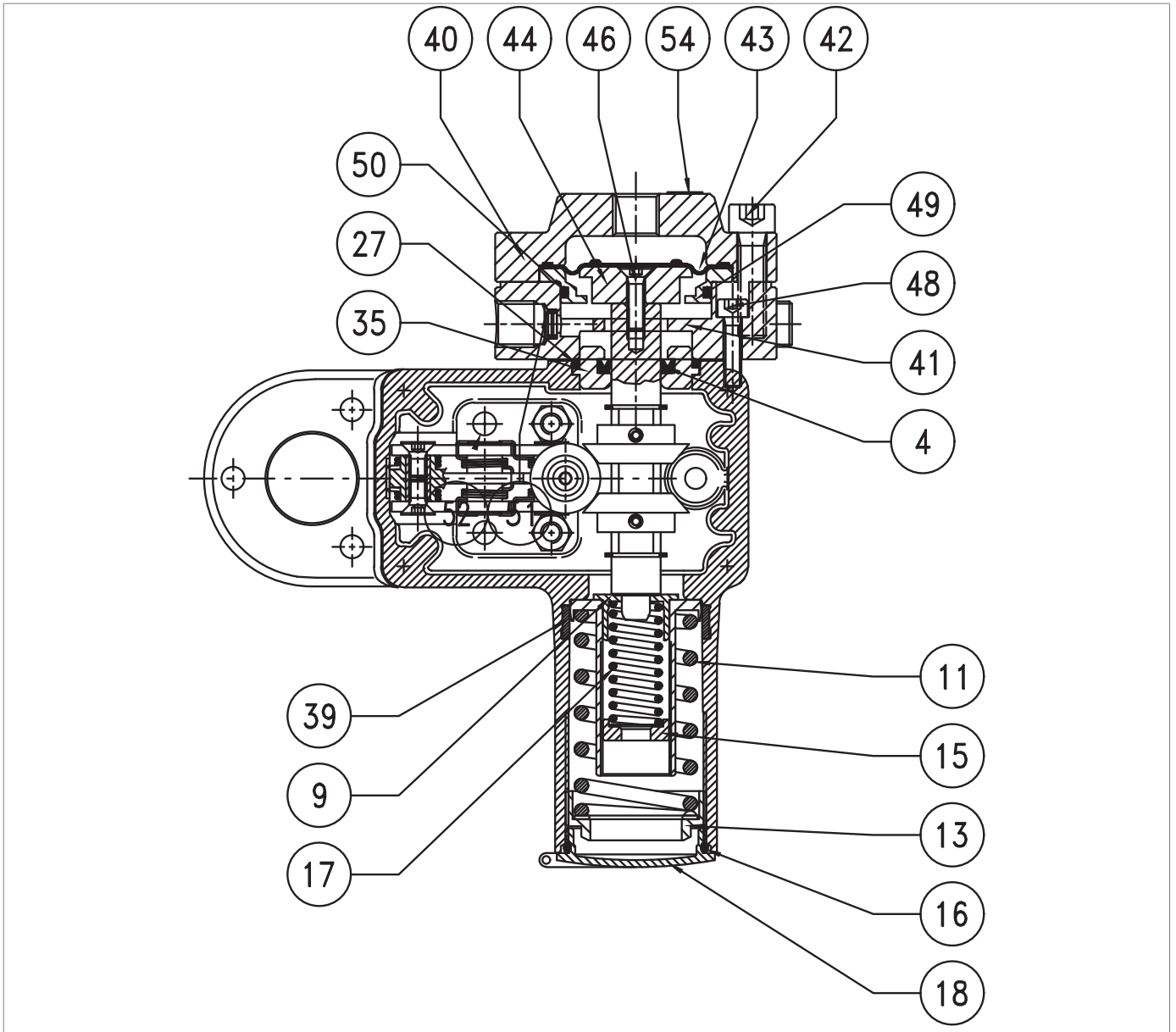

Fig. 9.75. Pressure switch Mod. 103M/103MH

Step	Action
1	Unscrew and remove the cap (18).
2	Remove the O-ring (16) from the cover (18) and replace it, lubricating it with synthetic grease. <b>! NOTICE!</b> <b>Before inserting the replacement O-ring, clean the retaining slots with a cleaning solution.</b>
3	Completely release the spring (11) by adjusting the ring nut (13).
4	Completely release the minimum pressure spring (17) by adjusting the ring nut (15). <b>! NOTICE!</b> <b>The minimum spring may not be installed.</b>
5	Remove the ring nut (13), the spring (11) and the spring support (17).
6	Remove the I/DWR ring (39) from the pressure switch sleeve and replace it, lubricating it with synthetic grease. <b>! NOTICE!</b> <b>Before fitting the replacement I/DWR ring, clean the retaining slots using a cleaning solution.</b>
7	Undo and remove the screws (42).
8	Remove the upper cover (40).
9	Remove and replace the diaphragm (43), lubricating the lanyard with synthetic grease. <b>! NOTICE!</b> <b>Before inserting the replacement diaphragm, clean the retaining slots with a cleaning solution.</b>
10	Undo and remove the screws (46).
11	Remove the ring (49).
12	Remove the O-ring (50) from the ring (49) and replace it. <b>! NOTICE!</b> <b>Before inserting the replacement O-ring, clean the retaining slots with a cleaning solution.</b>
13	Undo and remove the screws (48).
14	Remove the lower lid (41).
15	Remove the bush (35).
16	Remove the O-ring (27) from the bush (35) and replace it, lubricating it with synthetic grease. <b>! NOTICE!</b> <b>Before inserting the replacement O-ring, clean the retaining slots with a cleaning solution.</b>
17	Remove the U-shaped ring (4) from the bush (35) and replace it, lubricating it with synthetic grease. <b>! NOTICE!</b> <b>Before inserting the replacement U-ring, clean the retaining slots with a cleaning solution.</b>
18	Position the bush (35) together with the O-ring (27). <b>! NOTICE!</b> <b>Before inserting the bush (35), lubricate the internal surface with silicone grease.</b>



Pressure switch Mod. 103M/103MH

Step	Action
19	Remove the lower lid (41)
20	<p>Insert and fix the screws (48) according to the following tightening torque:</p> <ul style="list-style-type: none"> <li>• Mod. 103 : "Tab. 9.107".</li> </ul> <div style="border: 1px solid black; padding: 5px;"> <p><b>! NOTICE!</b></p> <ul style="list-style-type: none"> <li>• <b>Tighten the screws as shown in the diagram at "9.4.2.2 - Cross diagram for tightening screws";</b></li> <li>• <b>Make sure there is a gasket between the lower cover and the pressure switch body.</b></li> </ul> </div>
21	<p>Fit the diaphragm protection disc (44), then insert and secure the screw (46).</p> <div style="border: 1px solid black; padding: 5px;"> <p><b>! NOTICE!</b></p> <p><b>Before inserting the screw (46), apply thread locking glue.</b></p> </div>
22	<p>Insert and fix the screws (46) according to the following tightening torque:</p> <ul style="list-style-type: none"> <li>• Mod. 103 : "Tab. 9.107".</li> </ul> <div style="border: 1px solid black; padding: 5px;"> <p><b>! NOTICE!</b></p> <ul style="list-style-type: none"> <li>• <b>Tighten the screws as shown in the diagram at "9.4.2.2 - Cross diagram for tightening screws";</b></li> <li>• <b>Before inserting the screw (46), apply thread locking glue.</b></li> </ul> </div>
23	Fit the diaphragm (43).
24	Fit the lid (40).
25	<p>Insert and fix the screws (42) according to the following tightening torque:</p> <ul style="list-style-type: none"> <li>• Mod. 103 : "Tab. 9.107".</li> </ul> <div style="border: 1px solid black; padding: 5px;"> <p><b>! NOTICE!</b></p> <p><b>Tighten the screws as shown in the diagram at "9.4.2.2 - Cross diagram for tightening screws".</b></p> </div>

Tab. 9.144

 **WARNING!**

**Ensure that all parts have been fitted correctly.**

9.4.11.3 - PRESSURE SWITCH MOD. 104M/104MH ÷ 105M/105MH

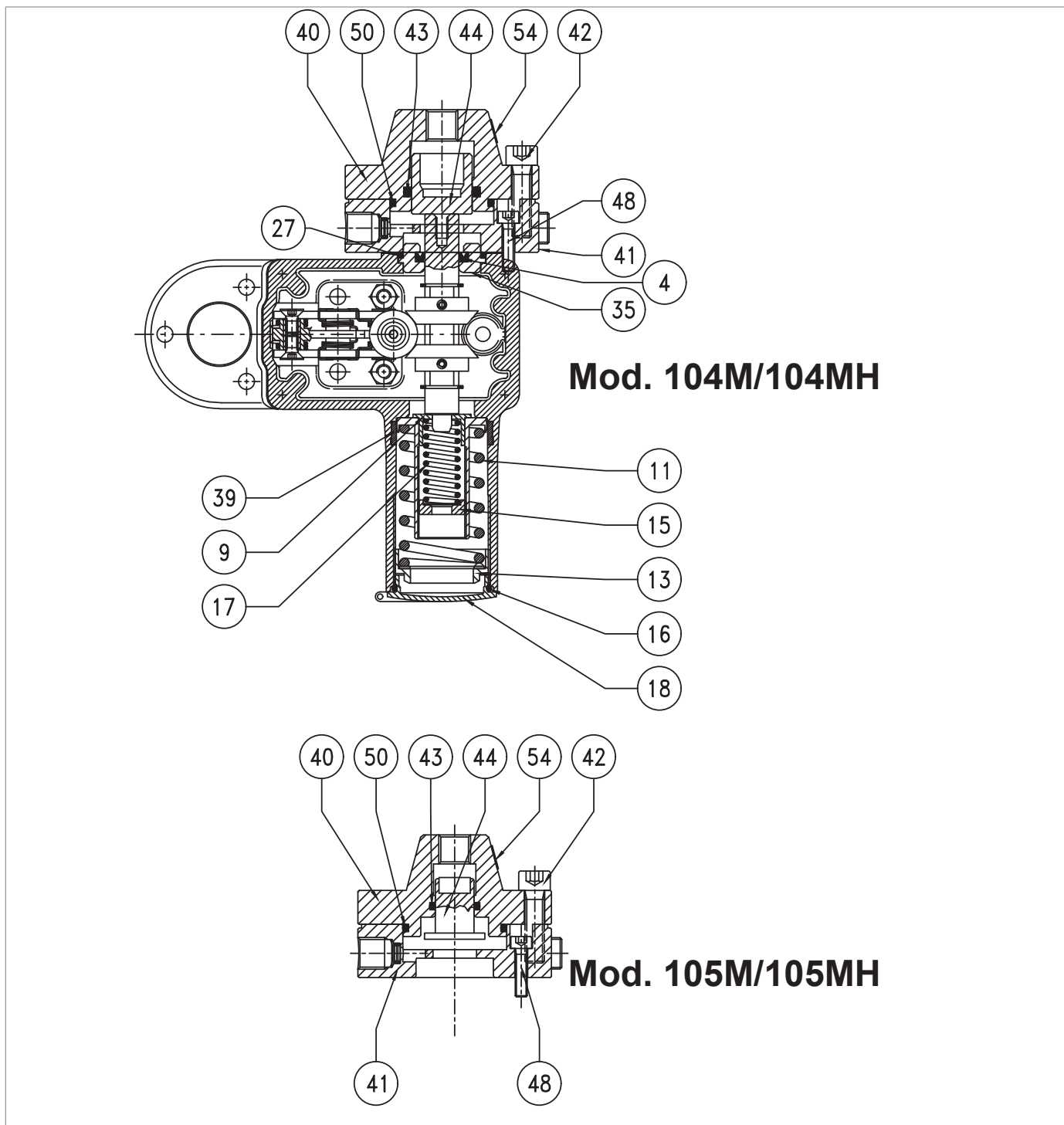
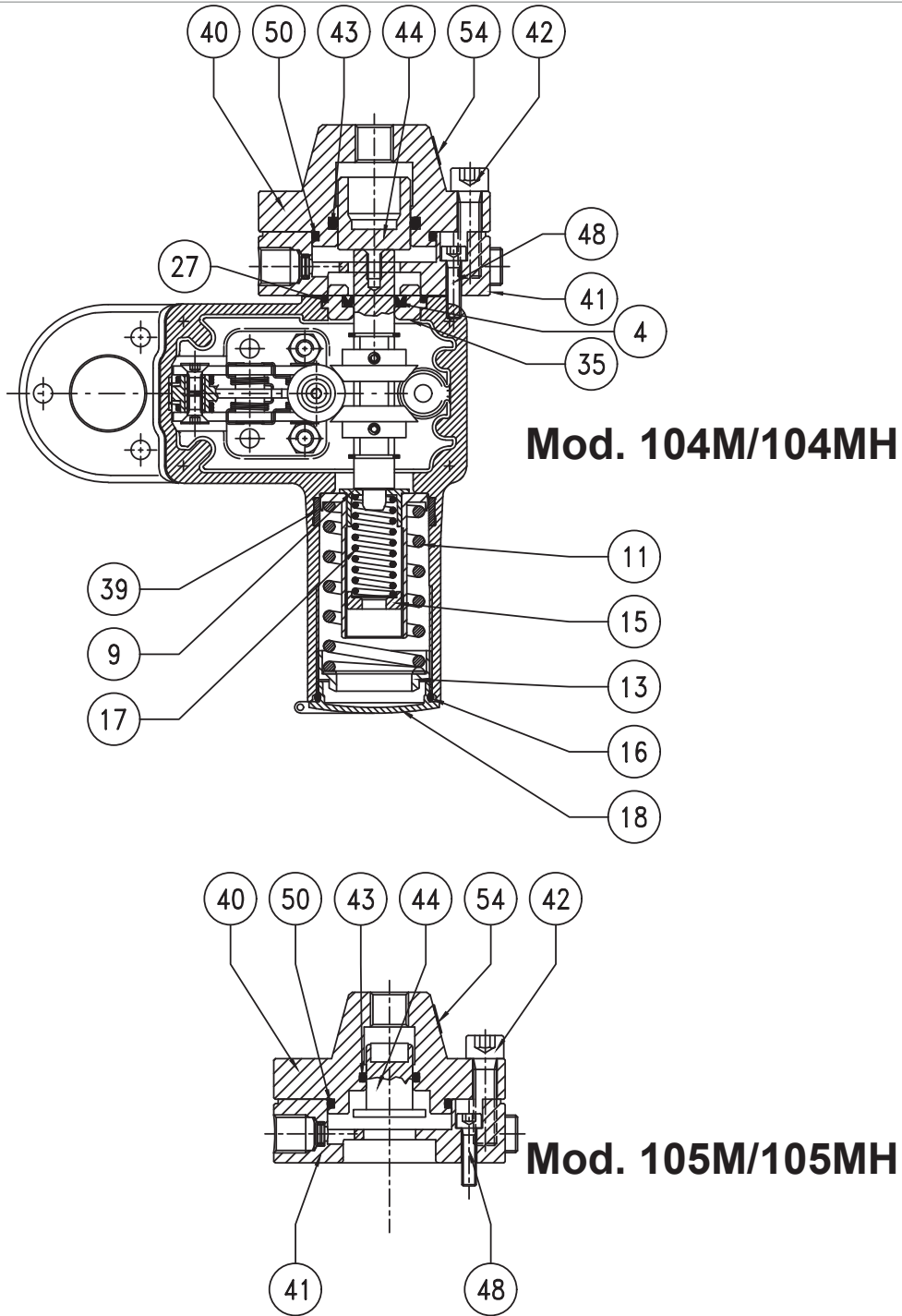



Fig. 9.76. Pressure switch Mod. 104M/104MH ÷ 105M/105MH

Step	Action
1	Unscrew and remove the cap (18).
2	Remove the O-ring (16) from the cover (18) and replace it, lubricating it with synthetic grease. <b>NOTICE!</b> <b>Before inserting the replacement O-ring, clean the retaining slots with a cleaning solution.</b>
3	Completely release the spring (11) by adjusting the ring nut (13).
4	Completely release the minimum pressure spring (17) by adjusting the ring nut (15). <b>NOTICE!</b> <b>The minimum spring may not be installed.</b>
5	Remove the ring nut (13), the spring (11) and the spring support (17).
6	Remove the I/DWR ring (39) from the pressure switch sleeve and replace it, lubricating it with synthetic grease. <b>NOTICE!</b> <b>Before fitting the replacement I/DWR ring, clean the retaining slots using a cleaning solution.</b>
7	Undo and remove the screws (42).
8	Remove the upper cover (40) together with the piston (44).
9	Pull the piston (44) out of the upper cover (40).
10	Remove the O-rings (43, 50) from the upper cover (40) and replace them, lubricating them with synthetic grease. <b>NOTICE!</b> <b>Before inserting the replacement O-rings, clean the retaining slots with a cleaning solution.</b>
11	Refit the piston (44) into the upper lid (40).
12	Undo and remove the screws (48).
13	Remove the lower lid (41).
14	Remove the bush (35).
15	Remove the O-ring (27) from the bush (35) and replace it, lubricating it with synthetic grease. <b>NOTICE!</b> <b>Before inserting the replacement O-ring, clean the retaining slots with a cleaning solution.</b>
16	Remove the U-shaped ring (4) from the bush (35) and replace it, lubricating it with synthetic grease. <b>NOTICE!</b> <b>Before inserting the replacement U-ring, clean the retaining slots with a cleaning solution.</b>
17	Position the bush (35) together with the O-ring (27). <b>NOTICE!</b> <b>Before inserting the bush (35), lubricate the internal surface with silicone grease.</b>
18	Fit the lower cover (41). <b>NOTICE!</b> <b>Make sure there is a gasket between the lower cover and the pressure switch body.</b>



Pressure switch Mod. 104M/104MH ÷ 105M/105MH

Step	Action
19	Insert and fix the screws (48) according to the following tightening torques: <ul style="list-style-type: none"> <li>Mod. 104-105: "Tab. 9.108".</li> </ul> <div style="border: 1px solid blue; padding: 2px;">  <b>NOTICE!</b> </div> <p><b>Tighten the screws as shown in the diagram at "9.4.2.2 - Cross diagram for tightening screws".</b></p>
20	Fit the upper cover (40).
21	Insert and fix the screws (42) according to the following tightening torques: <ul style="list-style-type: none"> <li>Mod. 104-105: "Tab. 9.108".</li> </ul> <div style="border: 1px solid blue; padding: 2px;">  <b>NOTICE!</b> </div> <p><b>Tighten the screws as shown in the diagram at "9.4.2.2 - Cross diagram for tightening screws".</b></p>

Tab. 9.145

 **WARNING!**

**Ensure that all parts have been fitted correctly.**

**9.4.12 - HB/97 BUILT-IN SLAM-SHUT VALVE MAINTENANCE PROCEDURE**

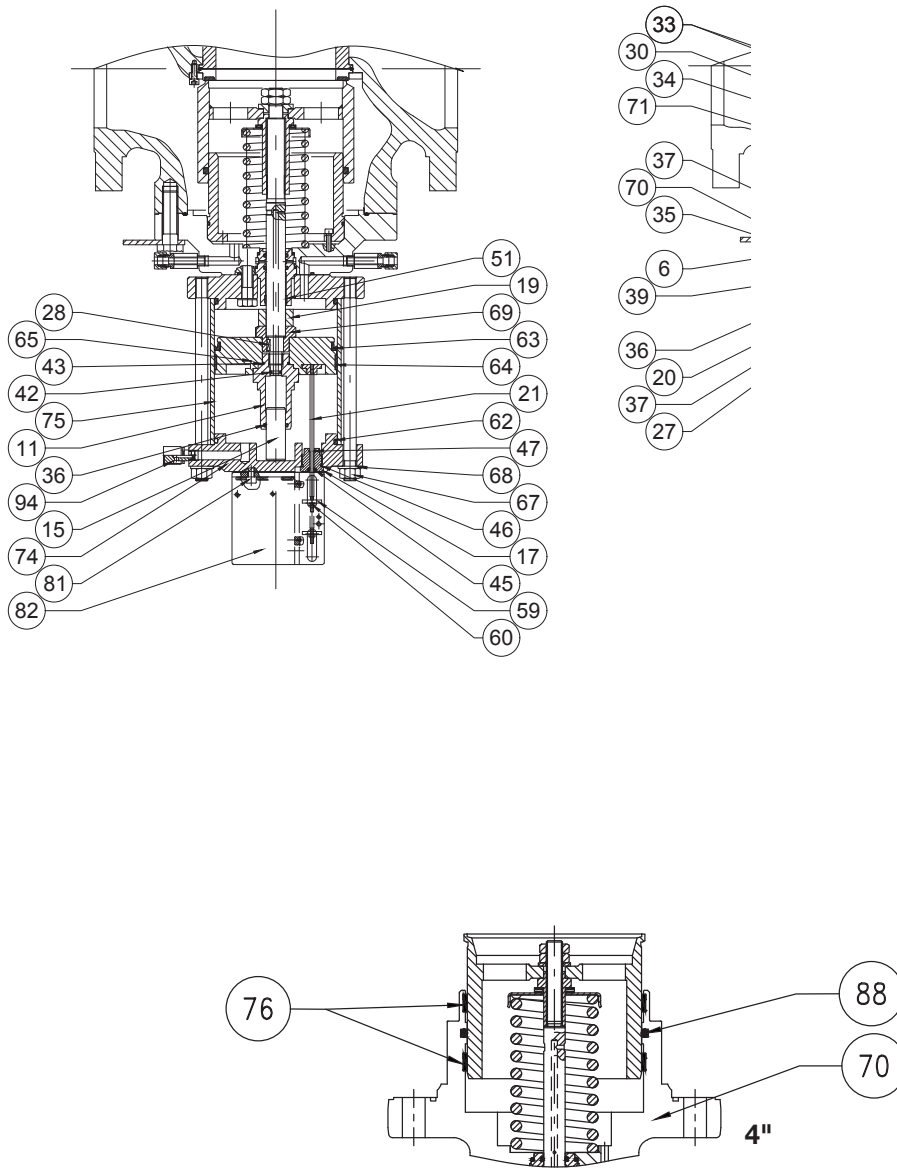
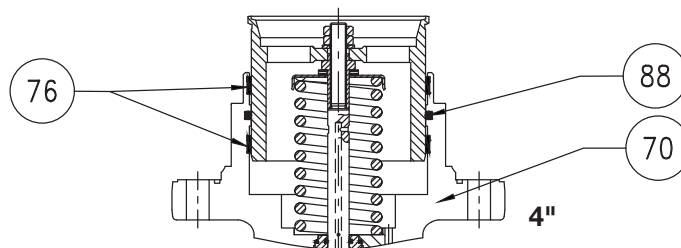
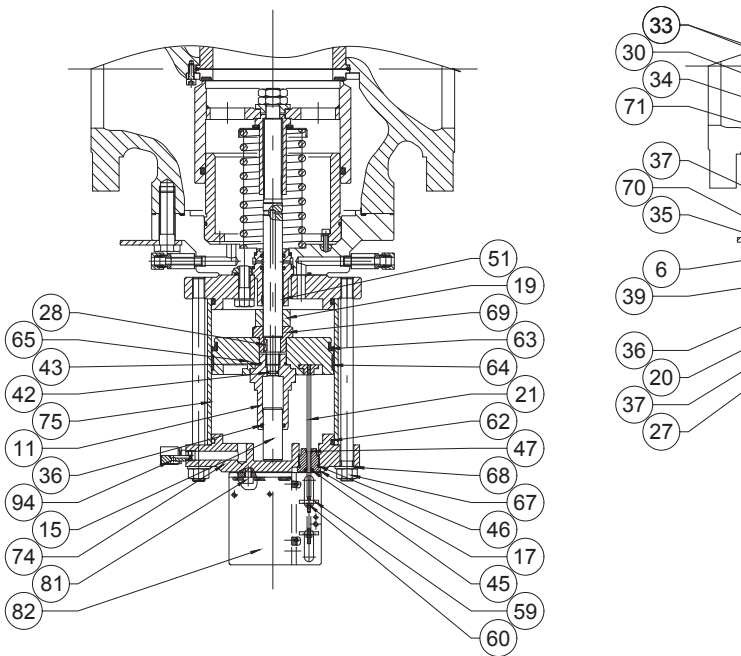

Fig. 9.77. HB/97 built-in slam-shut valve

Step	Action
1	<p><b>! NOTICE!</b></p> <p>To disconnect the LINE OFF 2.0 device, refer to paragraph “9.4.11.1 - Pressure switch Mod. 102M/102MH”.</p>
2	Undo and remove the screws (81).
3	Remove the bracket (82).
4	Unscrew and remove the nut (59) together with the indicator disc (60).
5	Unscrew and remove the nut (17).
6	Pull out the indicator rod (21).
7	Remove the guide O-ring (45) from the nut (17) and replace it, lubricating it with synthetic grease. <p><b>! NOTICE!</b></p> <p>Before inserting the replacement guide ring, clean the retaining slots with a cleaning solution.</p>
8	Remove the O-rings (46, 47) from the nut (17) and replace them, lubricating them with synthetic grease. <p><b>! NOTICE!</b></p> <p>Before inserting the replacement O-rings, clean the retaining slots with a cleaning solution.</p>
9	Undo and remove the screws (35). <p><b>! NOTICE!</b></p> <p>In this step, support the built-in SB/97 slam-shut valve to prevent any falls.</p>
10	Remove the HB/97 built-in slam-shut valve and fit it vertically with the plug (71) on an anti-shock surface.
11	Unscrew and remove the nuts (67) together with the washers (68).
12	Remove the flange (74). <p><b>! NOTICE!</b></p> <p>Check that the vent (94) is not clogged by dirt.</p>
13	Remove the O-ring (62) from the flange (74) and replace it, lubricating it with synthetic grease. <p><b>! NOTICE!</b></p> <p>Before inserting the replacement O-ring, clean the retaining slots with a cleaning solution.</p>
14	Remove the plating (75).
15	Fit the HB/97 built-in slam-shut valve sideways.
16	Unscrew and remove the nuts (33) together with the washer (23).
17	Remove the plug (71) and place it on an anti-shock surface.
18	<p><b>ONLY VALID FOR 4"</b></p> <p>Remove the O-ring (88) from the plug (70) and replace it, lubricating it with synthetic grease.</p> <p><b>! NOTICE!</b></p> <p>Before inserting the O-ring, clean the retaining slots with a cleaning solution.</p>



*HB/97 built-in slam-shut valve*

Step	Action
19	<p><b>ONLY VALID FOR 4"</b></p> <p>Remove the I/DWR rings (76) from the plug guide (70) and replace it, lubricating it with synthetic grease.</p> <p><b>! NOTICE!</b></p> <p><b>Before inserting the I/DWR rings, clean the retaining slots with a cleaning solution.</b></p>
20	<p>Remove the O-ring (88) from the plug (71) and replace it, lubricating it with synthetic grease.</p> <p><b>! NOTICE!</b></p> <p><b>Before inserting the replacement O-ring, clean the retaining slots with a cleaning solution.</b></p>
21	<p>While keeping the nut (69) in place, unscrew and remove the lock nut (9).</p> <p><b>! WARNING!</b></p> <p><b>By unscrewing the lock nut (9), the spring (80) is released.</b></p>
22	Remove the radial bearing (30).
23	Remove the spring support (34) and the spring (80).
24	While keeping the nut (69) in place, unscrew and remove the balancing piston guide (11).
25	Remove the balancing piston (15) from the balancing piston guide (11).
26	<p>Remove the O-rings (36, 43) from the balancing piston guide (11) and replace them, taking care to lubricate them with synthetic grease.</p> <p><b>! NOTICE!</b></p> <p><b>Before inserting the replacement O-rings, clean the retaining slots with a cleaning solution.</b></p>
27	Fit the balancing piston (15) from the balancing piston guide (11).
28	Take out the piston (65).
29	<p>Remove the U-shaped ring (63) from the bush (65) and replace it, lubricating it with synthetic grease.</p> <p><b>! NOTICE!</b></p> <ul style="list-style-type: none"> <li>• <b>Before inserting the replacement U-ring, clean the retaining slots with a cleaning solution.</b></li> <li>• <b>The concave part must face the flange (73).</b></li> </ul>
30	<p>Remove the I/DWR ring (64) from the piston (65) and replace it, lubricating it with synthetic grease.</p> <p><b>! NOTICE!</b></p> <p><b>Before inserting the replacement I/DWR ring, clean the retaining slots with a cleaning solution.</b></p>
31	Take out the nut (69).
32	<p><b>ONLY VALID FOR 6" ÷ 10"</b></p> <p>Remove the spacer (19).</p>
33	Undo and remove the screws (27) together with the washer (137).
34	Remove the flange (73).
35	<p>Remove the O-ring (62) from the flange (73) and replace it, lubricating it with synthetic grease.</p> <p><b>! NOTICE!</b></p> <p><b>Before inserting the replacement O-ring, clean the retaining slots with a cleaning solution.</b></p>

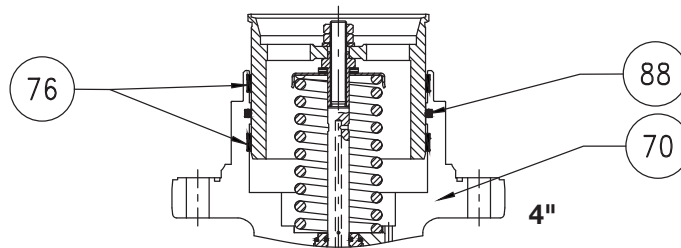
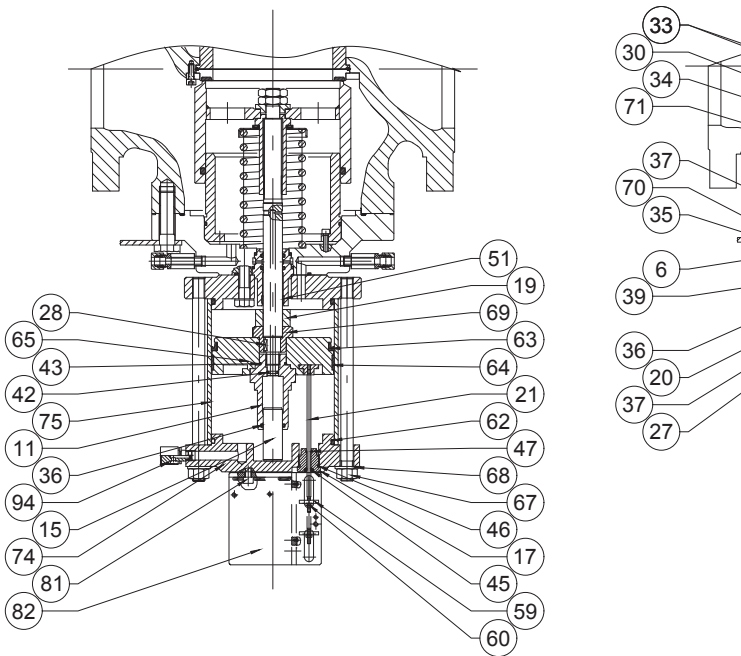

HB/97 built-in slam-shut valve

Step	Action
36	Remove the stem guide (20) together with the stem (6) and the key (28).
37	Remove the stem (6) from the stem guide (20).
38	Remove the I/DWR ring (51) from the stem guide (20) and replace it, lubricating it with synthetic grease. <b>! NOTICE!</b> <b>Before fitting the replacement I/DWR ring, clean the retaining slots using a cleaning solution.</b>
39	Remove the O-rings (36) from the stem guide (20) and replace them, lubricating them with synthetic grease. <b>! NOTICE!</b> <b>Before inserting the replacement O-rings, clean the retaining slots with a cleaning solution.</b>
40	Remove the O-rings (40, 41) from the stem guide (20) and replace them, lubricating them with synthetic grease. <b>! NOTICE!</b> <b>Before inserting the replacement O-rings, clean the retaining slots with a cleaning solution.</b>
41	Remove the O-ring (42) from the stem (6) and replace it, lubricating it with synthetic grease. <b>! NOTICE!</b> <b>Before inserting the replacement O-ring, clean the retaining slots with a cleaning solution.</b>
42	<b>VALID ONLY FOR 6"- 10"</b> Undo and remove the screws (86).
43	<b>VALID ONLY FOR 6"- 10"</b> Take out the plug guide (72). <b>! NOTICE!</b> <b>In this step, tighten some M6x50 screws into the threaded holes of the plug guide to remove it vertically.</b>
44	Remove the screws M6x50.
45	<b>VALID ONLY FOR 6"- 10"</b> Remove the O-ring (87) from the plug guide (72) and replace it, lubricating it with synthetic grease. <b>! NOTICE!</b> <b>Before inserting the replacement O-ring, clean the retaining slots with a cleaning solution.</b>
46	<b>VALID ONLY FOR 6"- 10"</b> Put the plug guide (72) in place.
47	<b>VALID ONLY FOR 6"- 10"</b> Insert and fix the screws (86) according to the following tightening torques: <ul style="list-style-type: none"> <li>• 6" : "Tab. 9.110";</li> <li>• 8" : "Tab. 9.111";</li> <li>• 10" : "Tab. 9.112".</li> </ul> <b>! NOTICE!</b> <b>Tighten the screws as shown in the diagram at "9.4.2.2 - Cross diagram for tightening screws".</b>

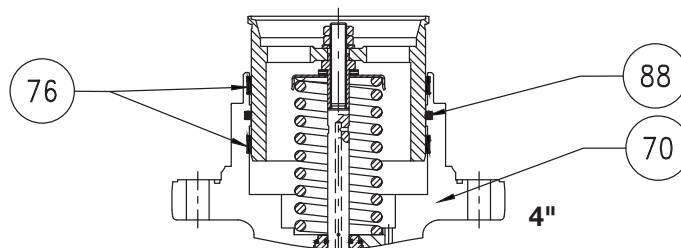
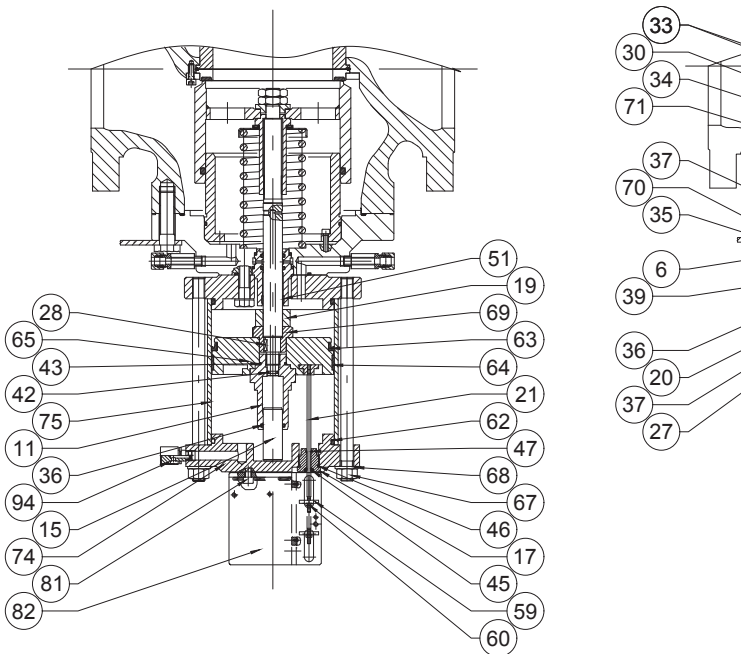





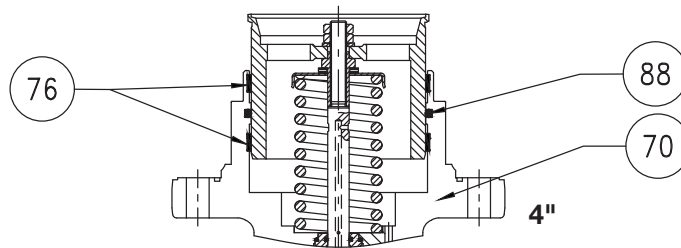
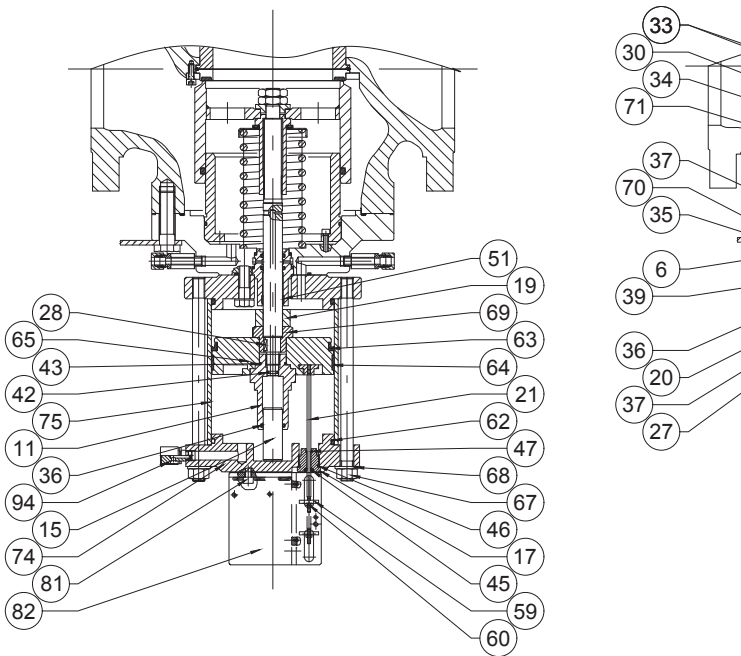



HB/97 built-in slam-shut valve

Step	Action
48	<p>Insert the stem (6) together with the key (28) in the stem guide (20).</p> <div style="border: 1px solid blue; padding: 5px;"> <p><b>! NOTICE!</b></p> <p><b>Clean and lubricate the stem surface with silicone grease; make sure that the key (28) is in the correct position in the stem (6).</b></p> </div>
49	Insert the stem guide (20) together with the stem (6) into the plug guide (70).
50	<p>Fit the flange (73).</p> <div style="border: 1px solid blue; padding: 5px;"> <p><b>! NOTICE!</b></p> <p><b>Match the chamber pressurisation hole with the plug guide hole (70)</b></p> </div>
51	<p>Insert and fix the screws (27) together with the washers (137) according to the following tightening torques:</p> <ul style="list-style-type: none"> <li>• 4" : "Tab. 9.109";</li> <li>• 6" : "Tab. 9.110";</li> <li>• 8" : "Tab. 9.111";</li> <li>• 10" : "Tab. 9.112".</li> </ul> <div style="border: 1px solid blue; padding: 5px;"> <p><b>! NOTICE!</b></p> <p><b>Tighten the screws as shown in the diagram at "9.4.2.2 - Cross diagram for tightening screws".</b></p> </div>
52	<p><b>VALID ONLY FOR 6"- 10"</b></p> <p>Insert the spacer (19).</p>
53	<p>Insert the nut (69).</p> <div style="border: 1px solid blue; padding: 5px;"> <p><b>! NOTICE!</b></p> <p><b>Make sure that the key (28) is present and correctly positioned in the stem (6).</b></p> </div>
54	Fit the piston (65).
55	<p>Keeping the nut (69) in position, insert and fix the balancing piston guide (11) according to the tightening torques:</p> <ul style="list-style-type: none"> <li>• 4" : "Tab. 9.109";</li> <li>• 6" : "Tab. 9.110";</li> <li>• 8" : "Tab. 9.111";</li> <li>• 10" : "Tab. 9.112".</li> </ul>
56	Position the spring (80), together with the spring support (34) and the radial bearing (30).
57	<p>Keeping the nut (69) in position, insert and fix the nut (9) according to the following tightening torques:</p> <ul style="list-style-type: none"> <li>• 4" : "Tab. 9.109";</li> <li>• 6" : "Tab. 9.110";</li> <li>• 8" : "Tab. 9.111";</li> <li>• 10" : "Tab. 9.112".</li> </ul>
58	Fit the plug (71).
59	<p>Fit the nut (23) together with the nuts (33) and fix them according to the following tightening torques:</p> <ul style="list-style-type: none"> <li>• 4" : "Tab. 9.109";</li> <li>• 6" : "Tab. 9.110";</li> <li>• 8" : "Tab. 9.111";</li> <li>• 10" : "Tab. 9.112".</li> </ul> <div style="border: 1px solid blue; padding: 5px;"> <p><b>! NOTICE!</b></p> <p><b>Before fitting the external nut (33), apply some thread locking glue.</b></p> </div>



HB/97 built-in slam-shut valve

Step	Action
60	Fit the plating (75). <div style="border: 1px solid black; padding: 5px;">  <b>NOTICE!</b>  <b>Before refitting the plating (75), clean and lubricate the internal surface with silicone grease.</b> </div>
61	Fit the upper flange (74). <div style="border: 1px solid black; padding: 5px;">  <b>NOTICE!</b>  <b>The stroke indicator hole must be perpendicular to the flow and visible in the in-line installation.</b> </div>
62	Insert and fix the nuts (67) according to the following tightening torques: <ul style="list-style-type: none"> <li>• 4" : "Tab. 9.109";</li> <li>• 6" : "Tab. 9.110";</li> <li>• 8" : "Tab. 9.111";</li> <li>• 10" : "Tab. 9.112".</li> </ul>
63	Remove the O-ring (37) from the flange (70) and replace it, taking care to lubricate it with synthetic grease. <div style="border: 1px solid black; padding: 5px;">  <b>NOTICE!</b>  <b>Before inserting the replacement O-ring, clean the retaining slots with a cleaning solution.</b> </div>
64	Put the HB/97 built-in slam-shut valve back in place. <div style="border: 1px solid black; padding: 5px;">  <b>NOTICE!</b>  <b>During this step, support the slam-shut device to prevent any falls.</b> </div>
65	Insert and fix the screws (35). <div style="border: 1px solid black; padding: 5px;">  <b>NOTICE!</b>  <b>Tighten the screws as shown in the diagram at "9.4.2.2 - Cross diagram for tightening screws".</b> </div>
66	Insert the indicator rod (21). <div style="border: 1px solid black; padding: 5px;">  <b>NOTICE!</b>  <b>The rod must be fitted into the slot in the piston (65).</b> </div>
67	Insert and fix the screws (17).
68	Put the bracket (82) in place.
69	Insert and fix the screws (81) according to the following tightening torques: <ul style="list-style-type: none"> <li>• 4" : "Tab. 9.109";</li> <li>• 6" : "Tab. 9.110";</li> <li>• 8" : "Tab. 9.111";</li> <li>• 10" : "Tab. 9.112".</li> </ul> <div style="border: 1px solid black; padding: 5px;">  <b>NOTICE!</b>  <b>Tighten the screws as shown in the diagram at "9.4.2.2 - Cross diagram for tightening screws".</b> </div>
70	Fit and set the indicator washer (59) to "0".
71	Insert and fix the screws (60).
72	<div style="border: 1px solid black; padding: 5px;">  <b>NOTICE!</b>  <b>To reconnect the LINE OFF 2.0, refer to "Tab. 9.148".</b> </div>

Tab. 9.146

 **WARNING!**

**Ensure that all parts have been fitted correctly.**

**9.4.13 - LINE OFF 2.0 MAINTENANCE PROCEDURE**

**9.4.13.1 - LINE OFF 2.0 DISCONNECTION**

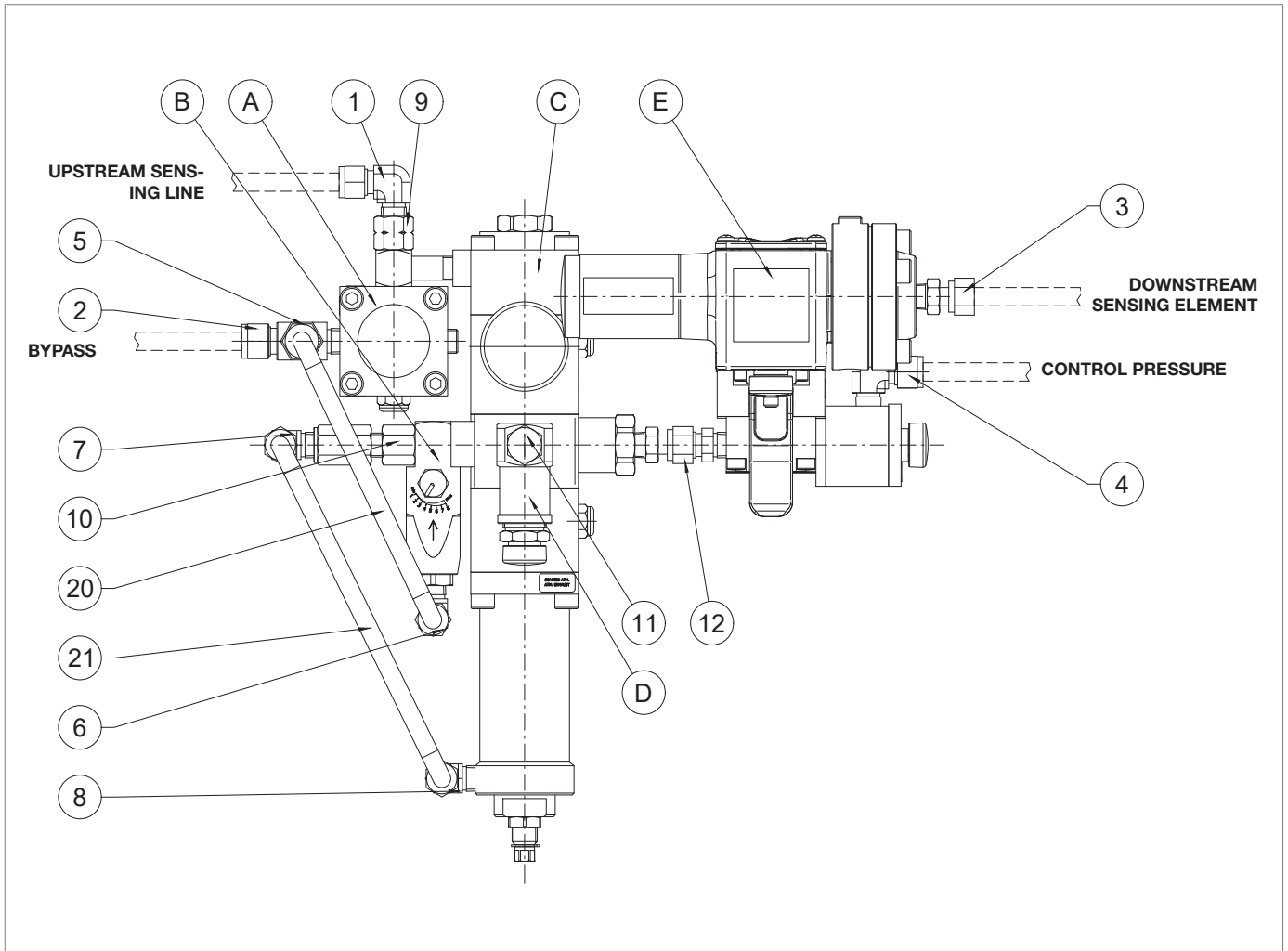

Fig. 9.78. LINE OFF 2.0

To disconnect, proceed as follows:

Step	Action
1	Disconnect the pipes from the fittings (1, 2, 3, 4).
2	Unscrew and remove the fixing screw to disconnect the LINE OFF 2.0.
3	Disconnect the pipe (20) from the fittings (5, 6).
4	Disconnect the pipe (21) from the fittings (7, 8).
5	Remove assembly "A" (bypass device <b>HP2/2</b> ) and adjust the fitting (9).
6	Remove assembly "B" (throttle valve <b>AR100</b> ) and adjust the fitting (10).
7	Remove assembly "D" (safety valve <b>VS/FI</b> ) and adjust the fitting (11).
8	Remove assembly "E" (valve <b>3/2</b> and control pressure switch) from assembly "C" (regulator <b>R44/SS</b> ) and adjust the fitting (12).

Tab. 9.147

To disconnect, proceed as follows:

Step	Action
1	Remove assembly "E" (valve <b>3/2</b> and control device) from assembly "C" (regulator <b>R44/SS</b> ) together with the fitting (12).
2	Remove assembly "D" (safety valve <b>VS/FI</b> ) together with the fitting (11).
3	Remove assembly "B" (throttle valve <b>AR100</b> ) together with the fitting (10).
4	Remove assembly "A" (bypass device <b>HP2/2</b> ) together with the fitting (9).
5	Reconnect the pipe (21) together with the fittings (7, 8).
6	Reconnect the pipe (20) together with the fittings (5, 6).
7	Insert and tighten the fixing screw to put the LINE OFF 2.0 in place.
8	Reconnect the pipes together with the fittings (1, 2, 3, 4).

Tab. 9.148

9.4.13.2 - HP2/2 BYPASS DEVICE

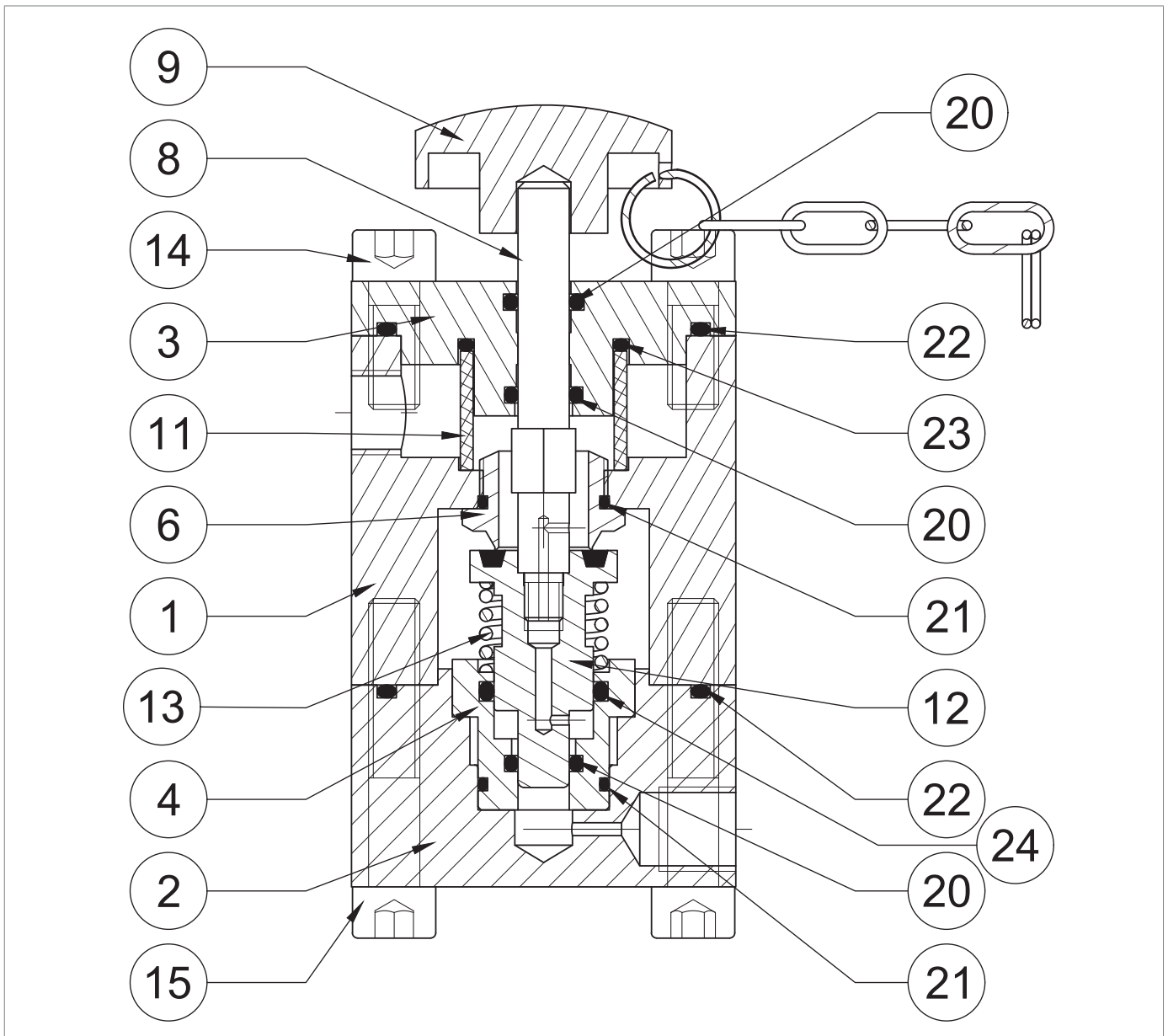







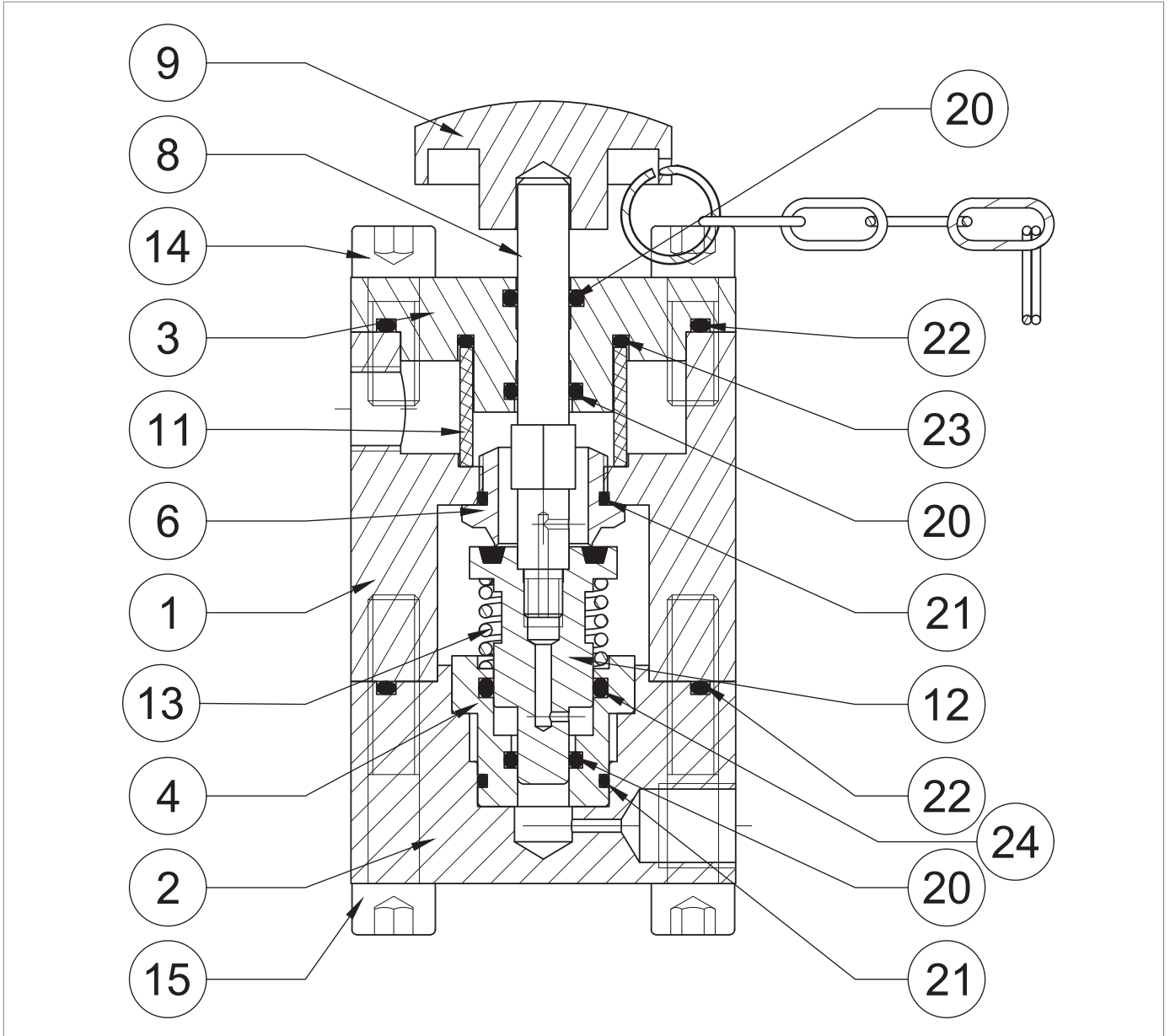

Fig. 9.79. HP2/2 bypass device

Step	Action
1	Remove the knob (9).
2	Undo and remove the screws (15).
3	Remove the cover (2) together with the bush (4), spring (13), plug (12) and stem (8).
4	Remove the bush (4), together with the spring (13), plug (12), stem (8) from the cover (2).
	Remove the O-ring (22) from the cover (2) and replace it, lubricating it with synthetic grease.
5	 <b>NOTICE!</b> <b>Before inserting the replacement O-ring, clean the retaining slots with a cleaning solution.</b>
6	Fit the plug (12) together with the stem (8).
7	Separate the stem (8) from the plug (12).
8	Replace the plug (12).
	Remove the O-rings (20, 21, 24) from the bush (4) and replace them, lubricating them with synthetic grease.
9	 <b>NOTICE!</b> <b>Before inserting the replacement O-rings, clean the retaining slots with a cleaning solution.</b>
	Undo and remove the screws (6).
10	 <b>NOTICE!</b> <b>Attention do not to ruin the seat profile during this step.</b>
	Remove the O-ring (21) from the seat (6) and replace it, lubricating it with synthetic grease.
11	 <b>NOTICE!</b> <b>Before inserting the replacement O-ring, clean the retaining slots with a cleaning solution.</b>
12	Undo and remove the screws (14).
13	Remove the flange (3).
	Remove the O-rings (22, 23) from the flange (3) and replace them, lubricating them with synthetic grease.
14	 <b>NOTICE!</b> <b>Before inserting the replacement O-rings, clean the retaining slots with a cleaning solution.</b>
	Remove the O-rings (20) from the flange (3) and replace them, lubricating them with synthetic grease.
15	 <b>NOTICE!</b> <b>Before inserting the replacement O-rings, clean the retaining slots with a cleaning solution.</b>
16	Remove and replace the filter (11).
17	Put the flange (3) back in place.
	Insert and fix the screws (14) according to the following tightening torque: <ul style="list-style-type: none"> <li>• HP2/2 : “Tab. 9.113”.</li> </ul>
18	 <b>NOTICE!</b> <b>Tighten the screws as shown in the diagram at “9.4.2.2 - Cross diagram for tightening screws”.</b>



HP2/2 bypass device

Step	Action
19	Fit and fix the seat (6) in the body (1). <b>NOTICE!</b> <b>Care must be taken not to ruin the seat profile during this step.</b>
20	Fit the bush (4) in the cover (2).
21	Screw the stem (8) into the plug (12). <b>NOTICE!</b> <b>Before fitting the stem (8), apply thread locking glue.</b>
22	Fit the spring (13).
23	Fit the plug (12) together with the stem (8) into the bush (4).
24	Fit the cover (2) together with the bush (4).
25	Insert and fix the screws (15) according to the following tightening torque: • HP2/2 : "Tab. 9.113". <b>NOTICE!</b> <b>Tighten the screws as shown in the diagram at "9.4.2.2 - Cross diagram for tightening screws".</b>

Tab. 9.149

### **WARNING!**

**Ensure that all parts have been fitted correctly.**

#### 9.4.13.3 - AR100 THROTTLE VALVE

### **NOTICE!**

**For more information, please refer to maintenance procedure 9.4.4 'Maintenance of 300/A series pilot + AR100 throttle valve'.**

9.4.13.4 - PRESSURE REGULATOR R44/SS

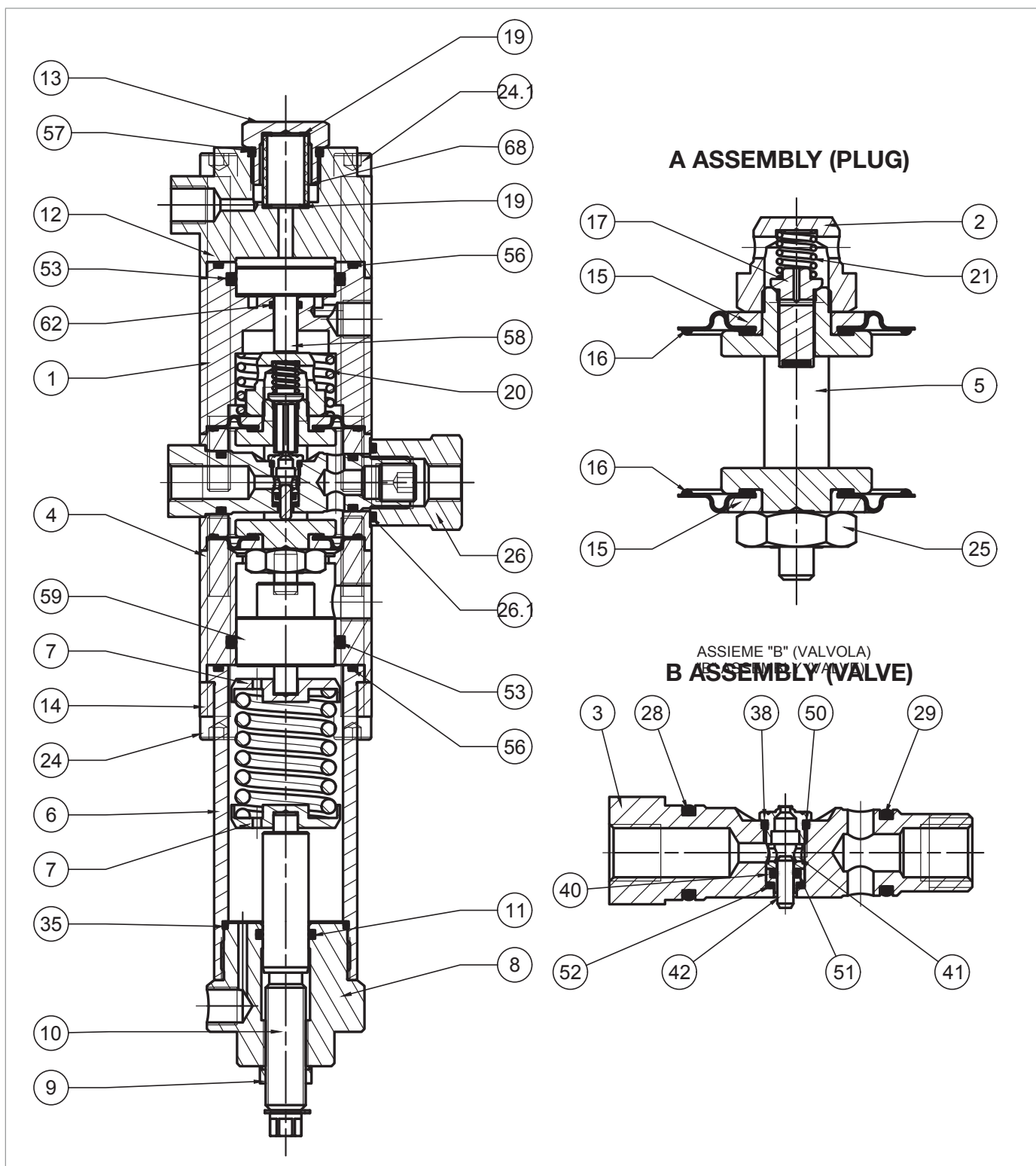
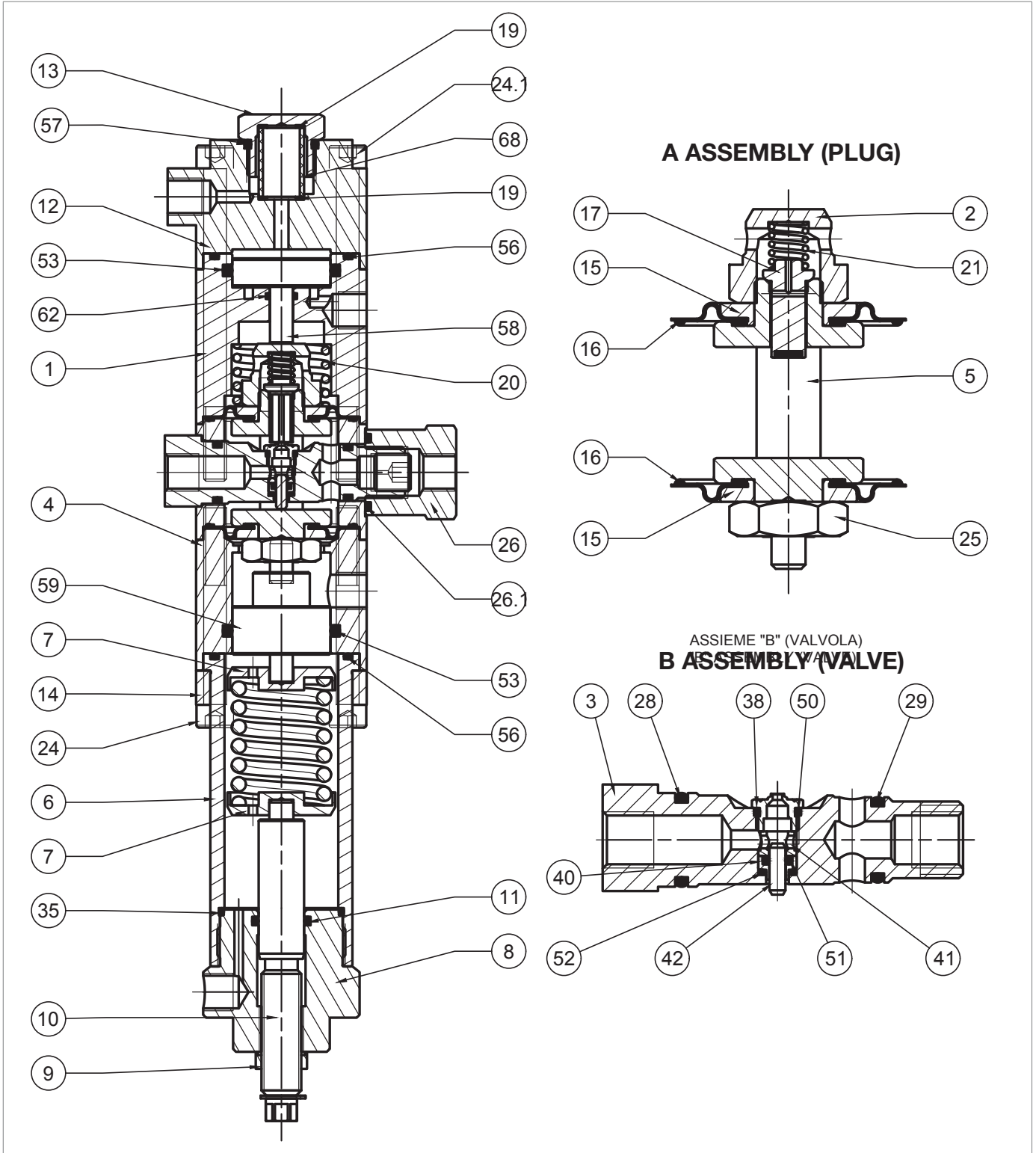

Fig. 9.80. Pressure regulator R44/SS

Step	Action
1	Remove the Seeger ring (54).
2	Unscrew the nut (9).
3	Completely release the spring (23) by turning the adjusting screw (10).
4	Unscrew and remove the cap (8).
5	Remove the spring (23) and the spring supports (7).
6	Remove the screw (10) from the cap (8) clockwise, from the inside outwards.
7	Remove the O-ring (11) from the cap (8) and replace it, lubricating it with synthetic grease. <div style="border: 1px solid black; padding: 5px;"><b>! NOTICE!</b>  <b>Before inserting the replacement O-ring, clean the retaining slots with a cleaning solution.</b></div>
8	Insert the screw (10) into the cap (8) anti-clockwise, from the outside inwards.
9	Insert the nut (9).
10	Fit the Seeger ring (54).
11	Undo the screws (24).
12	Remove the bracket (14).
13	Remove the sleeve (6).
14	Remove the O-ring (56) from the sleeve (6) and replace it, lubricating it with synthetic grease. <div style="border: 1px solid black; padding: 5px;"><b>! NOTICE!</b>  <b>Before inserting the replacement O-ring, clean the retaining slots with a cleaning solution.</b></div>
15	Remove the O-ring (35) from the sleeve (6) and replace it, lubricating it with synthetic grease. <div style="border: 1px solid black; padding: 5px;"><b>! NOTICE!</b>  <b>Before inserting the replacement O-ring, clean the retaining slots with a cleaning solution.</b></div>
16	Remove the spacer (4).
17	Take out the piston (59).
18	Remove the O-ring (53) from the spacer (4) and replace it, lubricating it with synthetic grease. <div style="border: 1px solid black; padding: 5px;"><b>! NOTICE!</b>  <b>Before inserting the replacement O-ring, clean the retaining slots with a cleaning solution.</b></div>
19	Unscrew and remove the cap (13).
20	Remove the O-ring (57) from the cap (13) and replace it, lubricating it with synthetic grease. <div style="border: 1px solid black; padding: 5px;"><b>! NOTICE!</b>  <b>Before inserting the replacement O-ring, clean the retaining slots with a cleaning solution.</b></div>
21	Remove and replace the filter (68).
22	Remove and replace the gaskets (19).
23	Undo and remove the screws (24.1).
24	Remove the cover (12).
25	Remove the cover (1).
26	Take out the piston (58).





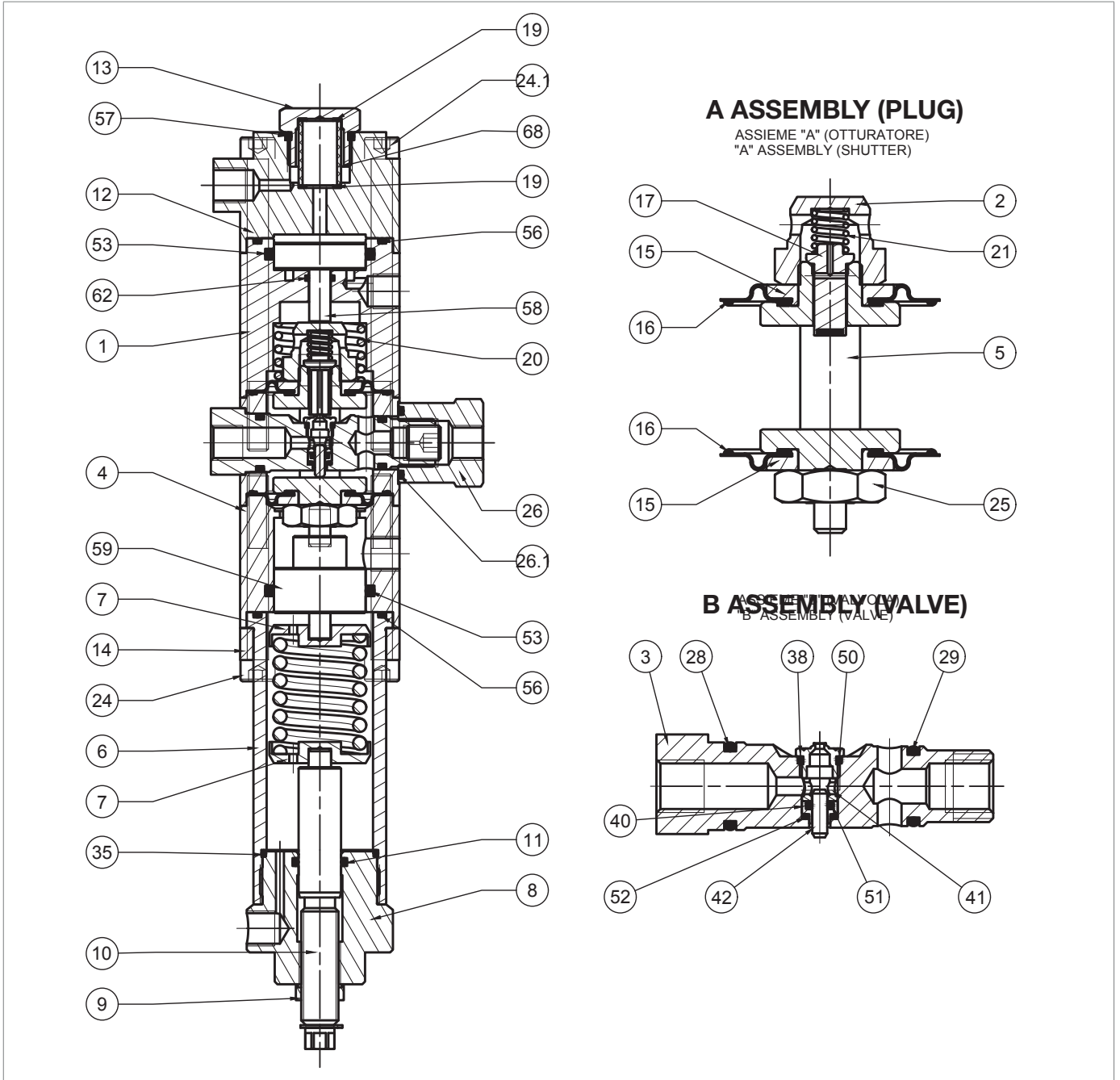

Pressure regulator R44/SS

Step	Action
27	Remove the O-ring (56) from the cover (1) and replace it, lubricating it with synthetic grease. <b>! NOTICE!</b> <b>Before inserting the replacement O-ring, clean the retaining slots with a cleaning solution.</b>
28	Remove the O-rings (53, 62) from the cover (1) and replace them, lubricating them with synthetic grease. <b>! NOTICE!</b> <b>Before inserting the replacement O-rings, clean the retaining slots with a cleaning solution.</b>
29	Remove the spring (20).
30	Unscrew the nut (26).
31	Remove the O-ring (26.1) from the nut (26) and replace it, lubricating it with synthetic grease. <b>! NOTICE!</b> <b>Before inserting the replacement O-ring, clean the retaining slots with a cleaning solution.</b>
32	Pull out the "B" (valve) assembly.
33	Unscrew the valve seat (38). <b>! NOTICE!</b> <b>Take care not to damage the surfaces.</b>
34	Remove the O-ring (50) from the valve seat (38) and replace it, lubricating it with synthetic grease. <b>! NOTICE!</b> <b>Before inserting the replacement O-ring, clean the retaining slots with a cleaning solution.</b>
35	Remove the bush (41).
36	Remove the balancing piston (42).
37	Take out the piston guide (40).
38	Remove the O-ring (51) from the piston guide (40) and replace it, lubricating it with synthetic grease. <b>! NOTICE!</b> <b>Before inserting the replacement O-ring, clean the retaining slots with a cleaning solution.</b>
39	Remove the O-ring (52) from the valve seat (3) and replace it, lubricating it with synthetic grease. <b>! NOTICE!</b> <b>Before inserting the replacement O-ring, clean the retaining slots with a cleaning solution.</b>
40	Remove the O-rings (28, 29) from the valve seat (3) and replace them, lubricating them with synthetic grease. <b>! NOTICE!</b> <b>Before inserting the replacement O-rings, clean the retaining slots with a cleaning solution.</b>
41	Fit the piston guide (40) and balancing piston (42).
42	Insert the bush (41) into the pilot seat (3) so that the wider stop rests on the O-ring (51).



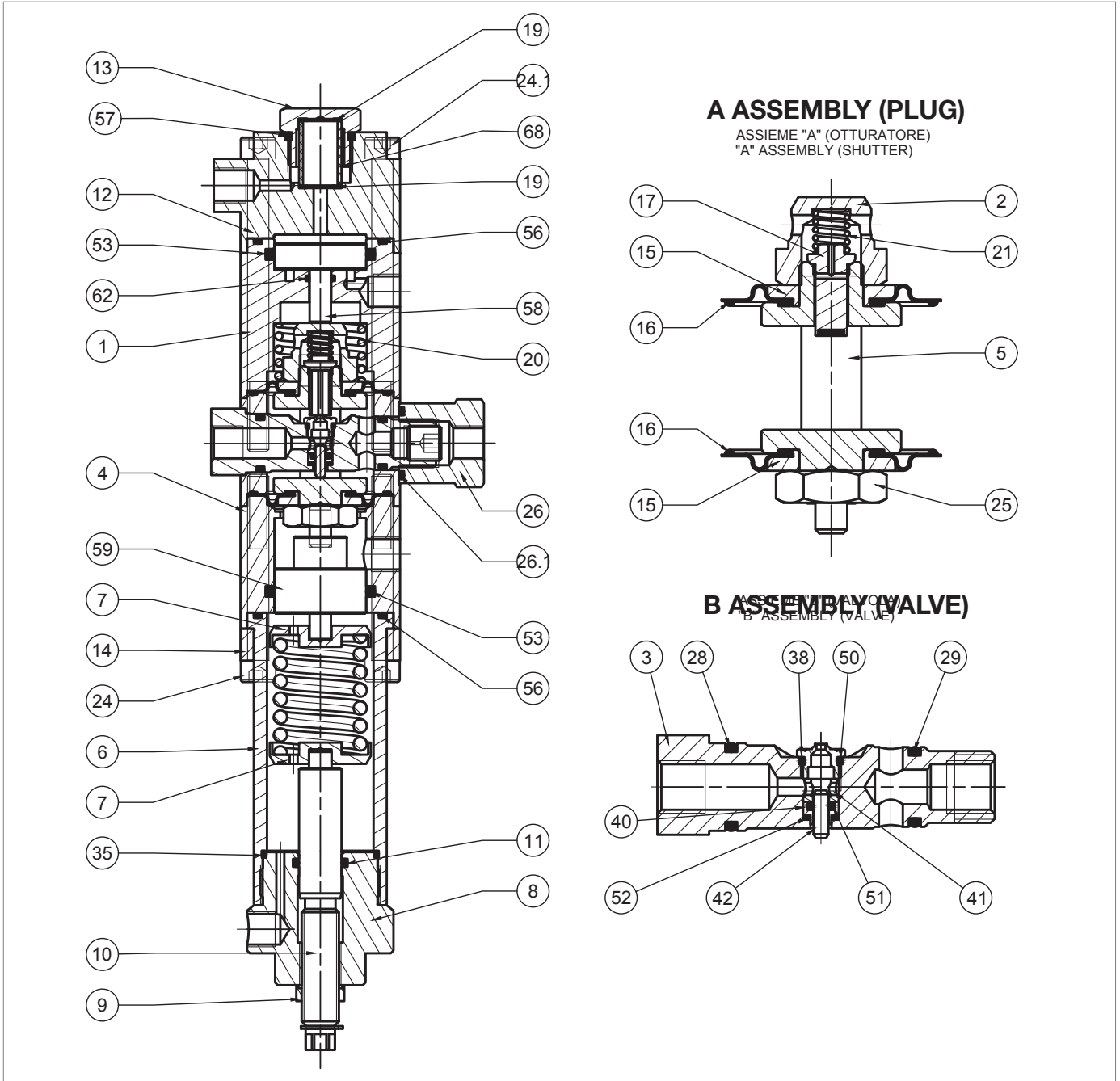

Pressure regulator R44/SS

Step	Action
43	Insert and fix the valve seat (38). <div style="border: 1px solid black; padding: 5px; margin-top: 5px;">  <b>NOTICE!</b>  <b>Take care not to damage the valve seat profile (38) and the O-ring (50).</b> </div>
44	Remove assembly "A" (plug) from the valve body (4).
45	Unscrew and remove the pilot nut (2).
46	Remove the spring (21).
47	Remove and replace the plug (17).
48	Remove the upper protection disc (15)
49	Remove and replace the upper diaphragm (16), lubricating the lanyards with synthetic grease. <div style="border: 1px solid black; padding: 5px; margin-top: 5px;">  <b>NOTICE!</b>  <b>Before inserting the replacement diaphragm, clean the retaining slots with a cleaning solution.</b> </div>
50	Unscrew and remove the nut (25).
51	Remove the lower protection disc (15).
52	Remove and replace the lower diaphragm (16), lubricating the lanyards with synthetic grease. <div style="border: 1px solid black; padding: 5px; margin-top: 5px;">  <b>NOTICE!</b>  <b>Before inserting the replacement diaphragm, clean the retaining slots with a cleaning solution.</b> </div>
53	Fit the lower protection disc (15).
54	Insert and fix the screws (25) according to the following tightening torque: <ul style="list-style-type: none"> <li>• R44/SS : "Tab. 9.114".</li> </ul>
55	Fit the upper protection disc (15).
56	Fit the plug (17).
57	Fit the spring (21).
58	Insert and fix the pilot nut (2) according to the following tightening torque: <ul style="list-style-type: none"> <li>• R44/SS : "Tab. 9.114".</li> </ul>
59	Insert assembly "A" (plug) from top to bottom into the valve body (4). <div style="border: 1px solid black; padding: 5px; margin-top: 5px;">  <b>NOTICE!</b>  <ul style="list-style-type: none"> <li>• <b>Take care not to damage the diaphragms (16) during this step;</b></li> <li>• <b>The marking on the lower section of the headframe (5) must be parallel to the axis of the hole for inserting the seat (3) into the valve body (4).</b></li> </ul> </div>
60	Insert assembly "B" (valve) into the valve body (4). <div style="border: 1px solid black; padding: 5px; margin-top: 5px;">  <b>NOTICE!</b>  <ul style="list-style-type: none"> <li>• <b>Insert the assembly with the valve seat (38) facing upwards;</b></li> <li>• <b>Take care not to damage the O-rings (28, 29) and the valve seat (38).</b></li> </ul> </div>
61	Screw in the nut (26) as far as it will go.
62	Fit the spring (20).
63	Insert the piston (58) into the cover (1).
64	Fit the covers (1 and 12).



Pressure regulator R44/SS

Step	Action
65	Insert and fix the screws (24.1) according to the following tightening torque: <ul style="list-style-type: none"> <li>R44/SS : "Tab. 9.114".</li> </ul> <div style="border: 1px solid black; padding: 5px;">  <b>NOTICE!</b>  <b>Tighten the screws as shown in the diagram at "9.4.2.2 - Cross diagram for tightening screws".</b> </div>
66	Fit the gaskets (19) and the filter (68).
67	Fit and secure the nut (13)
68	Fit the piston (59) into the spacer (4).
69	Fit the sleeve (6).
70	Put the bracket (14) back in place.
71	Insert and fix the screws (24) according to the following tightening torque: <ul style="list-style-type: none"> <li>R44/SS : "Tab. 9.114".</li> </ul> <div style="border: 1px solid black; padding: 5px;">  <b>NOTICE!</b>  <b>Tighten the screws as shown in the diagram at "9.4.2.2 - Cross diagram for tightening screws".</b> </div>
72	Insert the spring (23) together with the spring supports (7). <div style="border: 1px solid black; padding: 5px;">  <b>NOTICE!</b>  <b>Make sure that the piston pin (59) is inside the spring support (7).</b> </div>
73	Fit and secure the cap (8) to the sleeve (6).

Tab. 9.150

 **WARNING!**

**Ensure that all parts have been fitted correctly.**

 **WARNING!**

**Ensure that all parts have been fitted correctly.**

9.4.13.5 - SAFETY VALVE VS/FI FOR LINE OFF 2.0

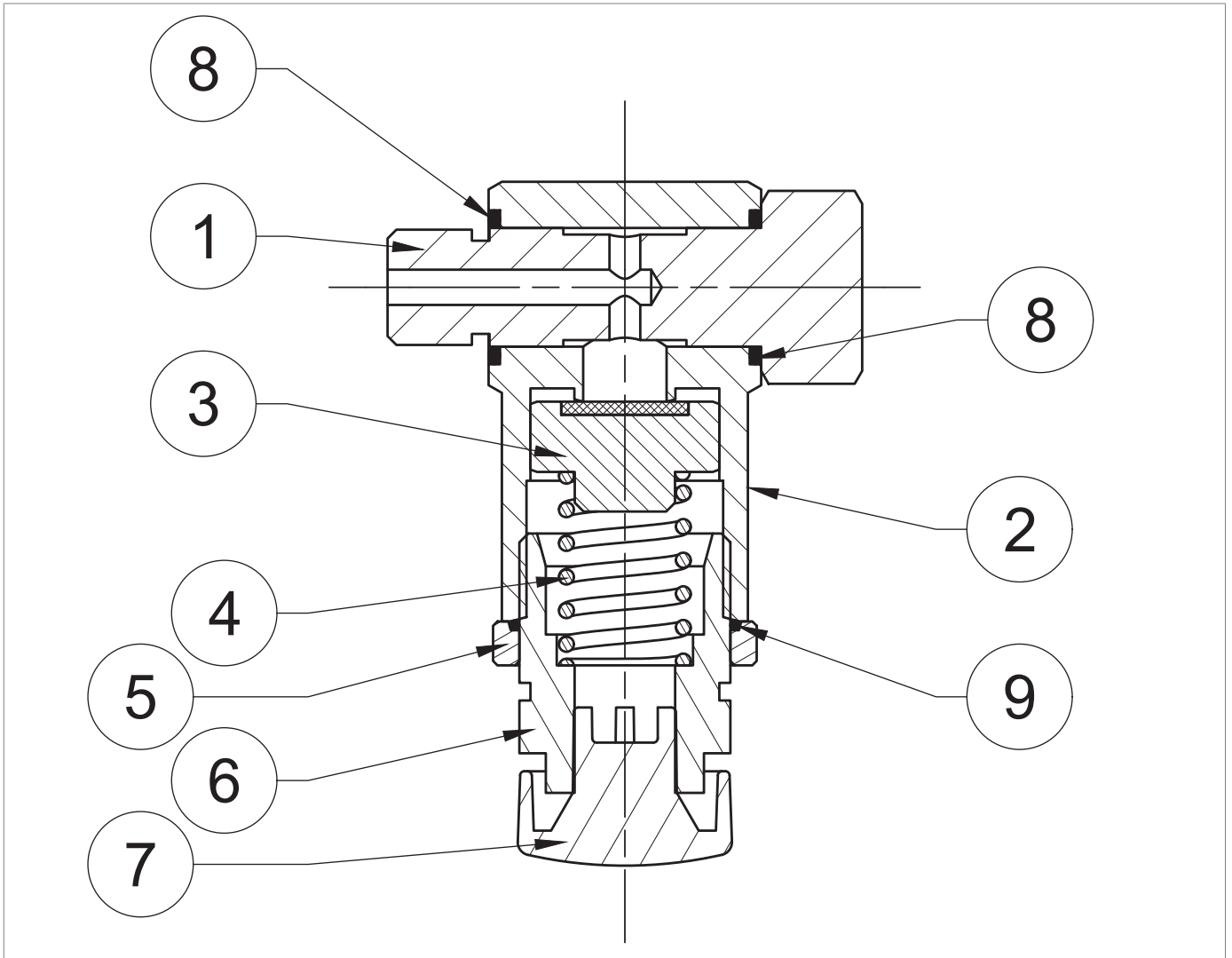

Fig. 9.81. Safety valve VS/FI for LINE OFF 2.0

Step	Action
1	Pull out the locking screw (1).
2	Remove the O-rings (8) from the body (2) and replace them, lubricating them with synthetic grease. <b>NOTICE!</b> <b>Before inserting the replacement O-ring, clean the retaining slots with a cleaning solution.</b>
3	Remove the vent plug (7) and make sure that it is not obstructed by any dirt.
4	Loosen the ring nut (5).
5	Unscrew and remove the cap (6).
6	Remove the O-ring (9) from the ring nut (5) and replace it, lubricating it with synthetic grease. <b>NOTICE!</b> <b>Before inserting the replacement O-ring, clean the retaining slots with a cleaning solution.</b>
7	Remove the spring (4).
8	Remove and replace the plug (3).
9	Insert the plug (3) and the spring (4).
10	Insert and screw in the cap (6).
11	Fit the vent cap (7).
12	Insert the locking screw (1).

Tab. 9.151

**! WARNING!**

**Ensure that all parts have been fitted correctly.**

**9.4.13.6 - PRESSURE SWITCHES MODELS 102 - 105**

**! NOTICE!**

**For more information, please refer to the chapter “9.4.11 - Maintenance procedure for Pressure Switches Models 102M/102MH - 105M/105MH”.**

9.4.13.7 - VALVE 3/2

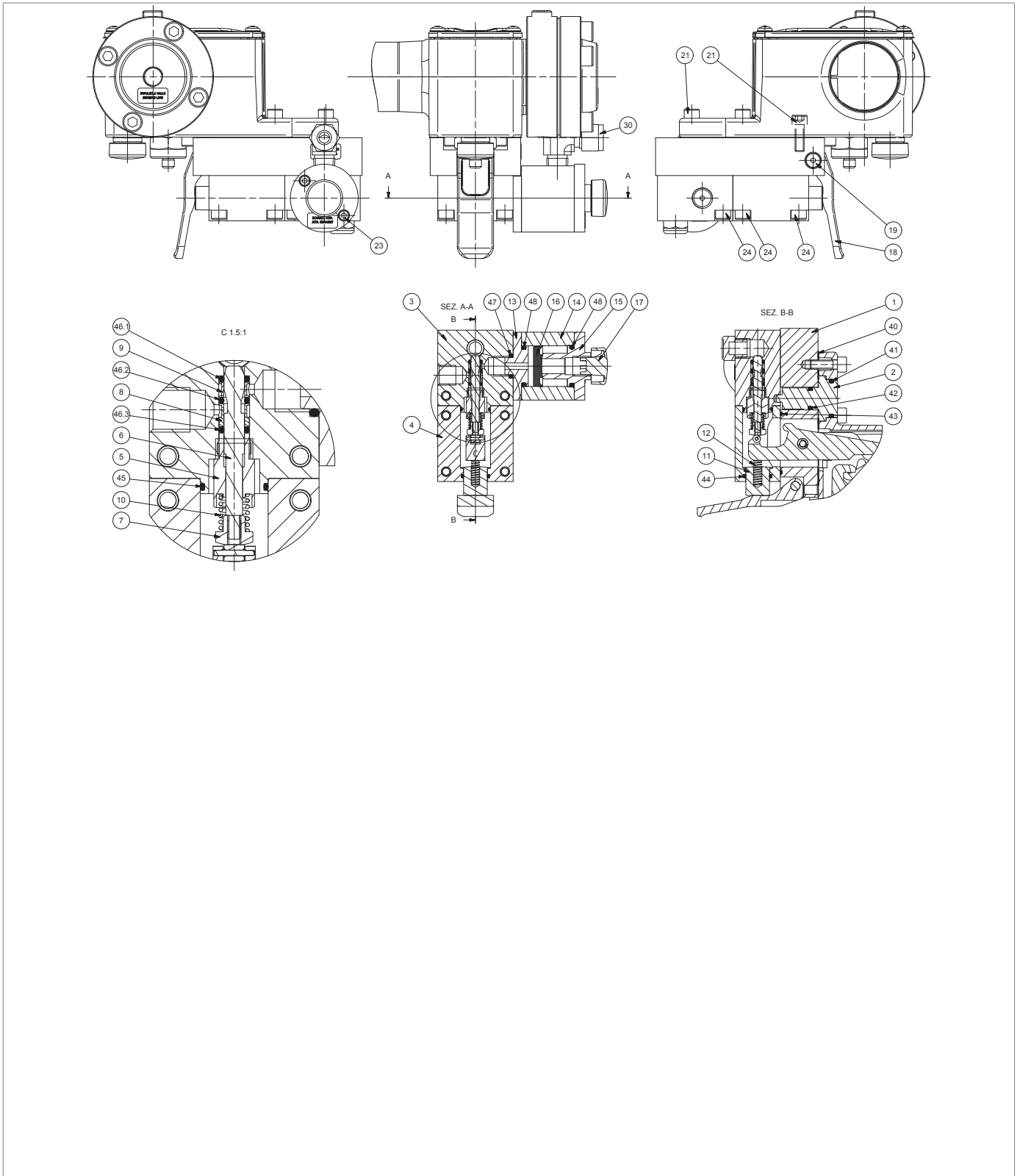







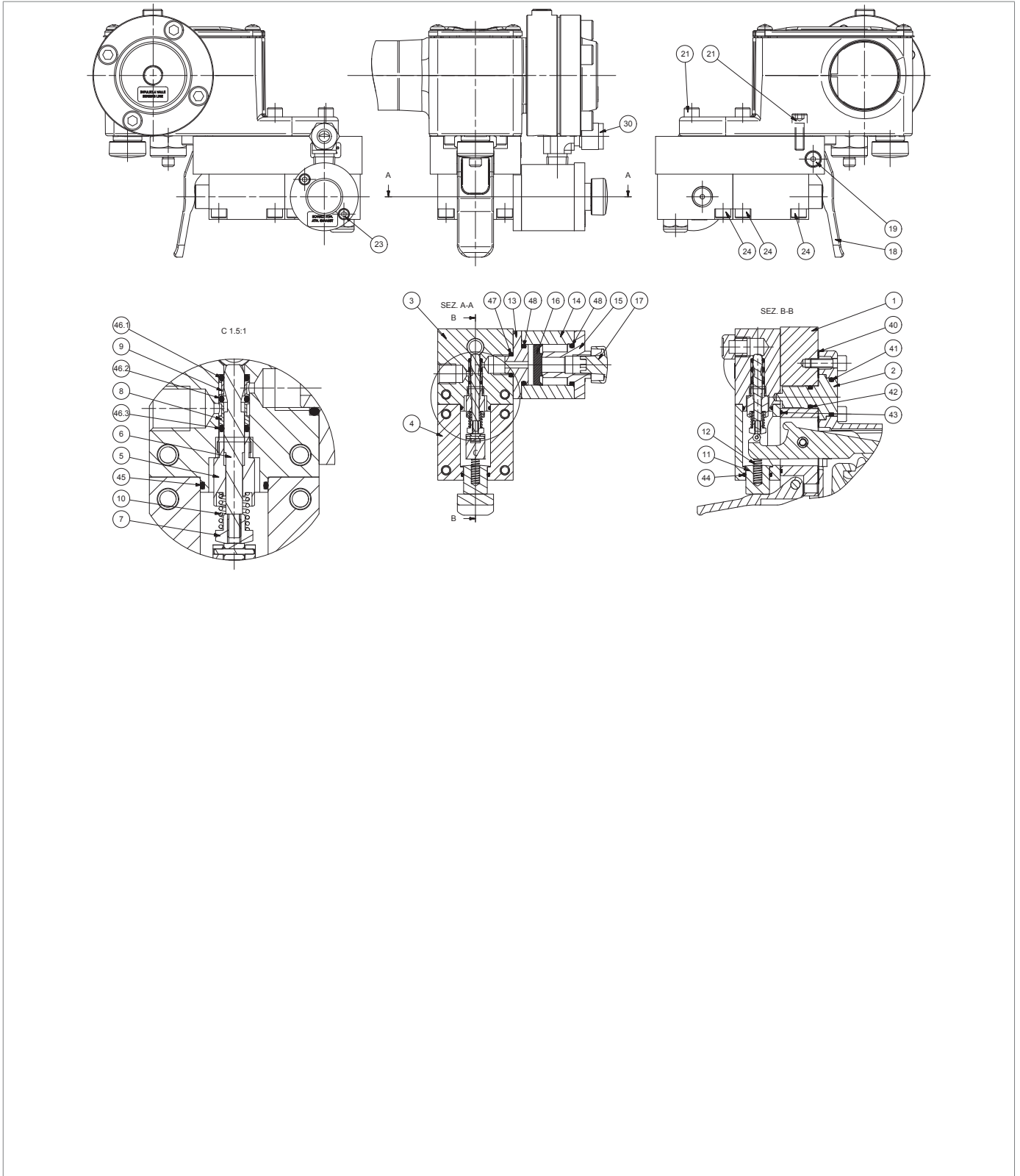

Fig. 9.82. Valve 3/2

Step	Action
1	 <b>NOTICE!</b> <b>Make sure the block is in the OFF state</b>
2	Undo and remove the screws (122) of the pressure switch cover (119).
3	Remove the pressure switch cover (119) together with the gasket (139).
4	Turn the device upside down.
5	Undo and remove the screw (19) and the lever (18).
6	Undo and remove the screws (23).
7	Remove the quick discharge assembly (13, 14, 15, 17).
8	Remove the O-ring (47) from the valve body (3) and lubricate it with synthetic grease.  <b>NOTICE!</b> <b>Before inserting the replacement O-ring, clean the retaining slots with a cleaning solution.</b>
9	Remove the locking flange (15).
10	Remove the O-ring (48) from the shut-off flange (15) and replace it, lubricating it with synthetic grease.  <b>NOTICE!</b> <b>Before inserting the replacement O-ring, clean the retaining slots with a cleaning solution.</b>
11	Remove and replace the gasket (16), lubricating it with synthetic grease.  <b>NOTICE!</b> <b>Orient the lip of the seal (16) towards the cover (15).</b>
12	Remove the intermediate flange (13).
13	Remove the O-ring (48) from the intermediate flange (13) and replace it, lubricating it with synthetic grease.  <b>NOTICE!</b> <b>Before inserting the replacement O-ring, clean the retaining slots with a cleaning solution.</b>
14	Undo and remove the screws (24).
15	Lift the valve body (3) together with the valve cover (4).
16	Separate the valve body (3) from the valve cover (4).
17	Remove the O-ring (45) from the valve cover (3) and lubricate it with synthetic grease.  <b>NOTICE!</b> <b>Before inserting the replacement O-ring, clean the retaining slots with a cleaning solution.</b>
18	Pull out the button (11) together with the spring (12),
19	Remove the O-ring (44) from the valve cover (4) and lubricate it with synthetic grease.  <b>NOTICE!</b> <b>Before inserting the replacement O-ring, clean the retaining slots with a cleaning solution.</b>
20	Fit the button (11) together with the spring (12).
21	Unscrew and remove the stem assembly (5, 6, 7, 8, 9, 10).
22	Remove the O-ring (46.3) and the bush (8).



Valve 3/2

Step	Action
23	Remove the O-ring (46.2) and the bush (9).
24	Remove the O-ring (46.1).
25	Replace the O-rings (46.1, 46.2 and 46.3) and lubricate them with synthetic grease. <b>! NOTICE!</b> <b>Before inserting the replacement O-rings, clean the retaining slots with a cleaning solution.</b>
26	Insert the O-ring (46.1) and the perforated bushing (9). <b>! NOTICE!</b> <b>Use the equipment (P) of "Tab. 7.48".</b>
27	Insert the O-ring (46.2) and the perforated bush (8). <b>! NOTICE!</b> <ul style="list-style-type: none"> <li>• Use the equipment (P) of "Tab. 7.48"</li> <li>• Align the bush (8) as shown in detail (C)</li> </ul>
28	Insert the O-ring (46.3). <b>! NOTICE!</b> <b>Use the equipment (P) of "Tab. 7.48".</b>
29	Insert and press the equipment (P) together with the O-rings (46.1, 46.2, 46.3) and the perforated bushes (8, 9) into the valve body (3).
30	Remove the equipment (P).
31	Insert and screw the stem assembly (5, 6, 7, 8, 9, 10).
32	Remove the O-ring (43) from the valve bracket (1) and replace it, lubricating it with synthetic grease. <b>! NOTICE!</b> <b>Before inserting the replacement O-ring, clean the retaining slots with a cleaning solution.</b>
33	Turn the device upside down.
34	Undo and remove the outer screws (21).
35	Undo and remove the inner screws (21).
36	Lift the pressure switch.
37	Remove the centring pin (2).
38	Remove the O-rings (41, 42) from the centring pin (2) and replace them, lubricating them with synthetic grease. <b>! NOTICE!</b> <b>Before inserting the replacement O-rings, clean the retaining slots with a cleaning solution.</b>
39	Remove and replace the gasket (40).
40	Fit the centring pin (2) on the valve bracket (1).
41	Assemble the pressure switch to the valve bracket (1).
42	Insert and fix the screws (21).
43	Insert and fix the internal screws (21).
44	Turn the device upside down.

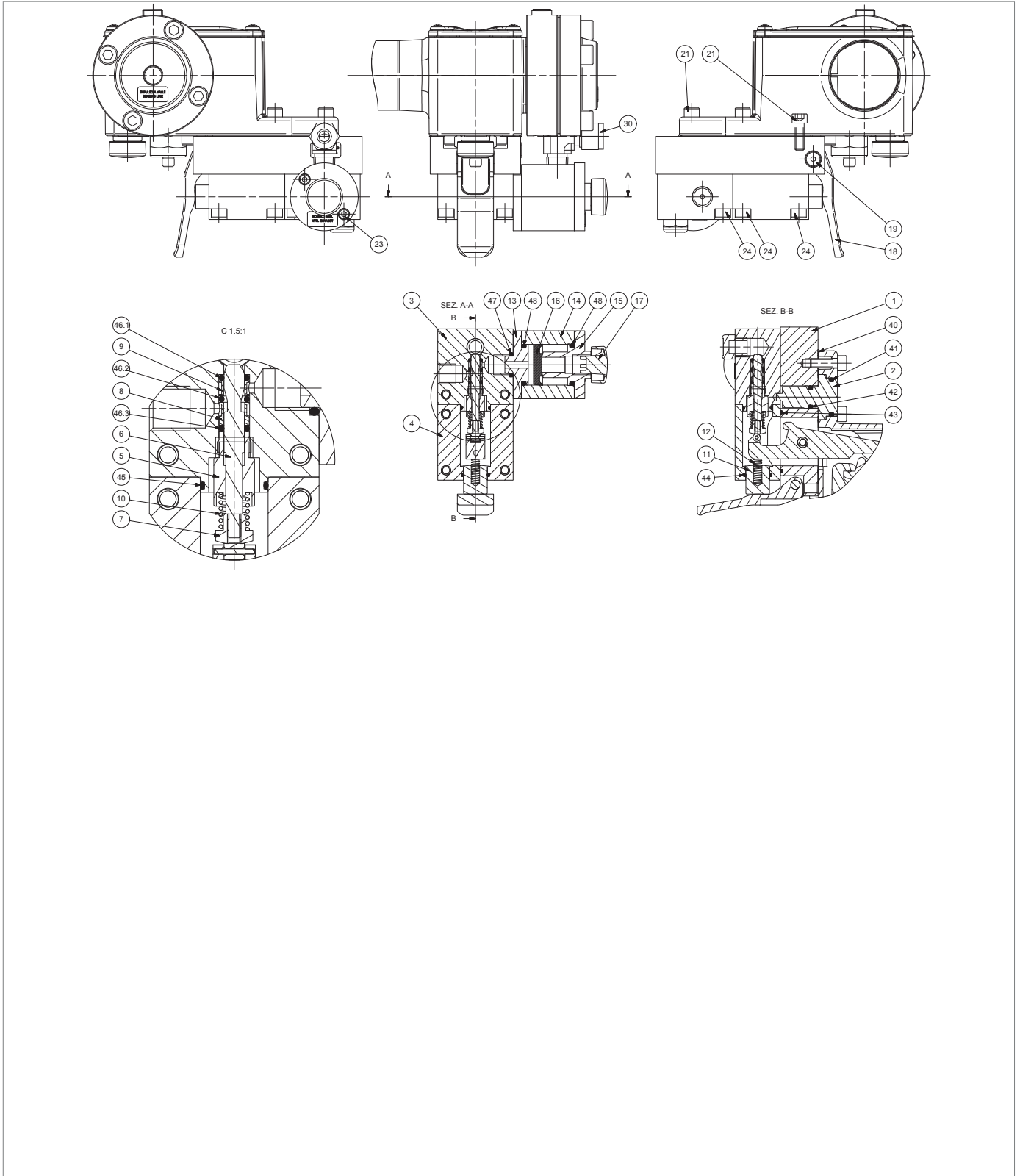

Valve 3/2

Step	Action
45	Insert the valve cover (4) so that the spring (12) rests on the lever of the pressure switch. <b>NOTICE!</b> <b>Keep the valve cover (4) tilted for easier assembly.</b>
46	Push and tilt the valve cover upwards (4).
47	Insert the valve body (3) together with the stem assembly (5, 6, 7, 8, 9, 10) into the valve cover (4). <b>NOTICE!</b> <b>The valve body (3) must be centred with the centring pin (2).</b>
48	Fasten the screws (24) of the valve body (3).
49	Fasten the screws (24) of the valve cover (4).
50	Fit the lever (18).
51	Insert and fix the screws (19).
52	Insert the flange (15) into the cylinder (14).
53	Insert the gasket (16) into the cylinder (14) with the flat side facing upwards.
54	Insert the flange (13) into the cylinder (14).
55	Insert the screws (23).
56	Fit the quick discharge assembly (13, 14, 15, 17) into the valve body (3).
57	Fix the screws (23).
58	Fit the cover (119) together with the gasket (139).
59	Insert and fix the screws (122) of the pressure switch.

Tab. 9.152

**WARNING!**

**Ensure that all parts have been fitted correctly.**

**9.4.13.8 - LINE OFF 2.0 RECONNECTION**

**NOTICE!**

**To reconnect the LINE OFF 2.0 refer to “Tab. 9.148”.**

**9.4.14 - PROCEDURE FOR RECOMMISSIONING AFTER MAINTENANCE**

**NOTICE!**

**For the recommissioning procedure, refer to the relevant paragraph.**

PAGE INTENTIONALLY LEFT BLANK

## 10 - TROUBLESHOOTING

Below is a list of the cases (causes and services) that may occur over time in the form of malfunctions of various kinds. These situations depend on the conditions of the gas as well as on the natural ageing and wear of the materials.

### 10.1 - GENERAL WARNINGS

#### **HAZARD!**

**Maintenance work must be carried out by qualified personnel:**

- trained in workplace safety also based on the regulations in force in the place of installation of the work equipment;
- qualified and authorised to carry out activities related to the equipment.

#### **WARNING!**





Shall not be held liable for any damage to people and property due to PIETRO FIORENTINI S.p.A. actions:

- other than those described;
- performed according to methods other than those specified;
- carried out by unsuitable personnel.

#### **NOTICE!**

If an operating fault occurs and qualified personnel are not available for the specific intervention, call the Assistance Centre authorised by PIETRO FIORENTINI S.p.A.

## 10.2 - OPERATOR QUALIFICATION SPECIFICATION

Commissioning	
<b>Operator qualification</b>	<ul style="list-style-type: none"> <li>• Mechanical maintenance technician;</li> <li>• Electrical maintenance technician;</li> <li>• Installer;</li> <li>• User technician.</li> </ul>
<b>PPE required</b>	<div style="display: flex; align-items: center; gap: 5px;">      </div> <div style="background-color: #f4a460; padding: 5px; margin-top: 5px;"> <p><b>⚠ WARNING!</b></p> </div> <p>The PPE listed in this table is related to the risk associated with the equipment. For the required PPE to protect against risks associated with the workplace, installation or operating conditions, please refer to:</p> <ul style="list-style-type: none"> <li>• the regulations in force in the country of installation;</li> <li>• <u>any information provided by the Safety Manager at the installation facility.</u></li> </ul>
<b>Equipment required</b>	Please refer to the chapter “7 - Commissioning/maintenance equipment”.

Tab. 10.153

## 10.3 - TROUBLESHOOTING PROCEDURES

For proper troubleshooting, proceed as follows:

- close the downstream shut-off valves;
- refer to the troubleshooting tables listed below.

## 10.4 - TROUBLESHOOTING TABLES

### NOTICE!

See chapter “9 - Maintenance and functional checks” for pictures of the regulator **APERFLUX 851** and its accessories.

### 10.4.1 - TROUBLESHOOTING REGULATOR APERFLUX 851

Failure	Device	Possible causes	Intervention
<b>Abnormalities of operation</b>	LAMINATION VALVE AR100	Unsuitable feed pressure to the regulator	Adjust the flow rate of the AR100 throttle valve
	SERIE 300 PILOTS	Diaphragm holder unit friction (16)	Centre the hole, assembly and shaft movement
		Balancing pin friction	Lubricate O-ring (51)
		Worn diaphragms (16)	Replace
		Diaphragm (49) worn (for 302/A pilot only)	Replace
		Spring (22) collapsed or out of level	Refit and replace if needed
	REGULATOR	Dirty or worn diaphragm (20)	Clean and replace if needed
		Diaphragm (20) out of level	Refit
		Unsuitable spring (45)	Replace
<b>Pumping</b>	LAMINATION VALVE AR100	Unsuitable feed pressure to the regulator	Adjust the flow rate of the AR100 throttle valve
	SERIE 300 PILOTS	Operating frictions	Check the pilot
<b>No sealing at zero flow</b>	SERIE 300 PILOTS	Dirty or worn plug (17)	Clean and replace if needed
		Failed sealing O-ring (50)	Clean and replace if needed
		Failed sealing O-ring (51)	Clean and replace if needed
		Failed sealing O-ring (52)	Clean and replace if needed
		Upper diaphragm (16) worn (excluding 302/A pilot)	Replace
		Failed sealing O-ring (18) (for pilots 304/A-305/A only)	Clean and replace if needed
	REGULATOR	Dirty or worn diaphragm (20)	Clean and replace if needed
		Diaphragm (20) out of level	Replace
		Failed sealing O-ring (39)	Clean and replace if needed
		Failed sealing O-ring (40)	Clean and replace if needed
		Failed sealing O-ring (41)	Clean and replace if needed

Failure	Device	Possible causes	Intervention
<b>Downstream pressure increases</b>	LAMINATION VALVE AR100	Filter cartridge clogging (11)	Replace
	SERIE 300 PILOTS	Plug (17) worn	Replace
		Diaphragm (49) worn (for 302/A pilot only)	Replace
		Worn diaphragms (16)	Replace
	REGULATOR	Diaphragm (20) worn	Replace
LAMINATION VALVE AR100	Incorrect adjustment	Adjust the flow rate of the AR100 throttle valve	
<b>Downstream pressure decreases</b>	SERIE 300 PILOTS	Ice formation on the valve seat	Increase pilot circuit gas inlet temperature
		Clogging due to valve seat soiling	Clean and check
	REGULATOR	Breakage within the sealing edge of the control element (20)	Replace

Tab. 10.154

## 10.4.2 - DB/851 SILENCER TROUBLESHOOTING

Failure	Device	Possible causes	Intervention
<b>Increase in noise</b>	DB/851 SILENCER	Breakage of the external basket (64)	Replace
<b>Failed sealing Zero flow rate</b>	DB/851 SILENCER	Failed sealing of the O-ring (39)	Clean and replace if needed
		Failed sealing of the O-ring (84)	Clean and replace if needed

Tab. 10.155

### 10.4.3 - APM/819 BUILT-IN MONITOR TROUBLESHOOTING

Failure	Device	Possible causes	Intervention
<b>Abnormalities of operation</b>	R14 PRE-REGULATOR	Dirty or worn plug (9)	Clean and replace if needed
		Guide ring (8) worn	Replace
	SERIE 200 PILOTS	Dirty or worn plug (17)	Clean and replace if needed
		Diaphragm holder unit friction (16)	Centre the hole, assembly and shaft movement
		Worn diaphragms (16)	Replace
		Spring (22) collapsed or out of level	Refit and replace if needed
		AC out of class due to unsuitable spring (22)	Replace
		SG out of class due to dirty or worn plug (17)	Clean and replace if needed
	REGULATOR	Reinforced gasket dirty or worn	Clean and replace if needed
		O-ring (35) friction	Lubricate and if needed replace
		Stem guide O-ring (36) frictions	Lubricate and if needed replace
		I/DWR (52) frictions	Lubricate and if needed replace
		I/DWR (51) friction	Lubricate and if needed replace
		Breakage of the diaphragm (50)	Replace
		SG out of class due to dirty or worn reinforced gasket	Clean and replace if needed

Failure	Device	Possible causes	Intervention	
<b>Failed sealing Zero flow rate</b>	R14 PRE-REGULATOR	Failed sealing of the O-ring (17)	Clean and replace if needed	
		Failed sealing of the O-ring (18)	Clean and replace if needed	
		Failed sealing of the O-ring (20)	Clean and replace if needed	
		Diaphragm (10) worn	Replace	
	SERIE 200 PILOTS	Diaphragm (16 upper) worn	Replace	
		Dirty or worn plug (17)	Clean and replace if needed	
			Reinforced gasket (8) dirty or worn	Clean and replace if needed
			Failed sealing of the O-ring (35)	Clean and replace if needed
			Failed sealing of the O-ring (36) of the balancing piston	Clean and replace if needed
			Failed sealing of the O-ring (42)	Clean and replace if needed
			Failed sealing of the O-ring (43)	Clean and replace if needed
	<b>Downstream pressure increases</b>	R14 PRE-REGULATOR	Plug (9) damaged	Replace
SERIE 200 PILOTS		Plug (17) damaged	Replace	
		Diaphragm holder (16) and plug (17) assembly locked in open position	Check and clean if needed	
		Plug spring collapsed	Replace	
		Downstream sensing line obstructed	Clean	
REGULATOR			Reinforced gasket (8) damaged	Replace
			Ice between reinforced gasket (8) and plug (71)	Increase the gas inlet temperature of the regulator
			Soiling between reinforced gasket (8) and plug (71)	Clean and check gas filtration
			Plug (71) locked	Clean and check the movements
			Imperfect control-element unit tightening	Tighten properly
			Transfer hole clogged	Clean
			Plug guide O-ring (35) damaged	Replace
			Stem guide O-ring (36) frictions	Lubricate and if needed replace
			I/DWR (52) frictions	Lubricate and if needed replace
I/DWR (51) friction		Lubricate and if needed replace		
	Spring (80) collapsed	Replace		

Failure	Device	Possible causes	Intervention
<b>Downstream pressure decreases</b>	PRE-REGULATOR R14/A	Filter clogging (13)	Replace
		Plug (9) deformation	Replace
		Diaphragm (10) damaged	Replace
		Blocked stem (203) in closing	Clean and lubricate
		Stem (5) clogged	Clean
	SERIE 200 PILOTS	Plug (17) locked in shut-off position	Clean and lubricate
		Diaphragms (16) damaged	Replace
		Diaphragm holder (16) and plug (17) assembly locked in open position	Check and clean if needed
		Valve seat (3) clogged	Clean
		Spring (22) collapsed	Replace
	PM 819 MONITOR	No upstream pressure	Check line filter cartridges for clogging
		Plug (71) locked	Clean and check the movements
		Dirty O-ring (35)	Clean and replace if needed
		Stem guide O-Ring (36) frictions	Lubricate and if needed replace
		I/DWR (52) frictions	Lubricate and if needed replace
		I/DWR (51) friction	Lubricate and if needed replace
		Ice formation	Increase gas inlet temperature regulator
Diaphragm (50) damaged		Replace	
Nut (11) loosened	Tighten		

Tab. 10.156

#### 10.4.4 - SB/82 BUILT-IN SLAM-SHUT VALVE TROUBLESHOOTING

**⚠ WARNING!**

If the built-in slam-shut valve tripped, close the inlet and outlet valves (V1 and V2) of the line before any other operation and discharge pressure.

Failure	Device	Possible causes	Intervention
<b>Incorrect release pressure</b>	SLAM-SHUT VALVE SB/82 BUILT-IN SLAM-SHUT VALVE	Incorrect spring calibration of max. and/or min.	Repeat calibration by adjusting the ring nuts. If the minimum setting is also required, recalibrate the maximum and minimum springs several times in this sequence
		Lever mechanisms with friction	Clean and lubricate the the lever mechanisms and if needed replace the box
	PRESSURE SWITCHES MODELS 101 ÷ 105	Springs (11.17) collapsed	Replace
		Springs (11.17) out of level	Refit
<b>Impossible to reset</b>	SLAM-SHUT VALVE SB/82 BUILT-IN SLAM-SHUT VALVE	Max. and/or min. pressure spring incorrect calibration.	Repeat calibration by adjusting the ring nuts
		The downstream pressure is not consistent with the min and/or max setting of the slam-shut device	Adjust the downstream pressure
	PRESSURE SWITCHES MODELS 101 ÷ 105	Levers broken or chipped	Changing the standard box containing the entire complex
		Membrane rupture (43) if min. spring is present.	Replace
<b>Failure to provide service</b>	SLAM-SHUT VALVE SB/82 BUILT-IN SLAM-SHUT VALVE	Blocked stem (6) in opening	Clean and lubricate
		Locked lever mechanisms	Clean and lubricate
	PRESSURE SWITCHES MODELS 101 ÷ 105	Membrane rupture (43) if min. spring is missing.	Replace

Failure	Device	Possible causes	Intervention
<b>Downstream pressure increase with slam-shut device shutting off</b>	SLAM-SHUT VALVE SB/82 BUILT-IN SLAM-SHUT VALVE DN 1" - 3"	Failed sealing of the O-ring (40)	Clean and replace if needed
		Shutter pad (19) drawer	Clean and replace if needed
		Conical seat (8) damaged	Replace
		Failed sealing of the O-ring (39)	Clean and replace if needed
	SLAM-SHUT VALVE SB/82 BUILT-IN SLAM-SHUT VALVE DN 4" - 8"	Failed sealing of the O-ring (40)	Clean and replace if needed
		Shutter pad (19) drawer	Clean and replace if needed
		Failed sealing of the O-ring (44)	Clean and replace if needed
		Conical seat (8) damaged	Replace
	SLAM-SHUT VALVE SB/82 BUILT-IN SLAM-SHUT VALVE DN 10"	Failed sealing of the O-ring (39)	Clean and replace if needed
		Reinforced gasket (8) drawer	Clean and replace if needed
		Failed sealing of the O-ring (42)	Clean and replace if needed
		Valve seat (2) damaged	Replace
	BYPASS DEVICE HP2/2	Failed sealing of the pad O-ring (5)	Clean and replace if needed
		Failed sealing of the O-ring (15)	Clean and replace if needed
		Valve seat (6) damaged	Replace
		Failed sealing of the O-ring (20)	Clean and replace if needed

*Tab. 10.157*

## 10.4.5 - HB/97 BUILT-IN SLAM-SHUT VALVE TROUBLESHOOTING

### WARNING!

If the built-in slam-shut valve tripped, close the inlet and outlet valves (V1 and V2) of the line before any other operation and discharge pressure.

Failure	Device	Possible causes	Intervention
<b>Incorrect release pressure</b>	PRESSURE SWITCHES MODELS 101 ÷ 105	Max. and/or min. pressure spring incorrect calibration.	Repeat calibration by adjusting the ring nuts
		Lever mechanisms with friction	Clean and lubricate the lever mechanisms and if necessary replace the box
		Springs (11.17) collapsed	Replace
		Springs (11.17) out of level	Refit
<b>Impossible to reset</b>	SLAM-SHUT VALVE HB/97 BUILT-IN SLAM-SHUT VALVE	Stem (6) locked due to friction	Clean and lubricate
		Stem (6) locked in shut-off position	Clean and lubricate
		Plug (71) locked due to friction	Clean and lubricate
		U-ring (63) damaged	Replace
		I/DWR ring (64) damaged	Replace
	PRESSURE SWITCHES MODELS 101 ÷ 105	Wrong calibration spring of max and / or min.	Repeat calibration by adjusting the ring nuts
		The downstream pressure is not consistent with the min and/or max setting of the slam-shut device	Adjust the downstream pressure
		Lever mechanisms with friction	Clean and lubricate the lever mechanisms and if needed replace the box
		Breakage of the Diaphragm breakage (43) if a min. pressure spring is installed.	Replace
		Release button manual locked	Clean and lubricate
	BYPASS DEVICE HP2/2	Filter (11) clogged	Replace

Failure	Device	Possible causes	Intervention
<b>Delayed shut-off</b>	LAMINATION VALVE AR100	Filter (5) clogged	Replace
	PRESSURE REGULATOR R44/SS	Lower diaphragm (16) breakage	Replace
		Upper diaphragm (16) breakage	Replace
		Failed sealing of the upper O-ring (53)	Clean and replace if needed
		Failed sealing of the lower O-ring (53)	Clean and replace if needed
		Failed sealing of the O-ring (11)	Clean and replace if needed
		Failed sealing of the O-ring (35)	Clean and replace if needed
		Balancing piston (42) locked	Clean and lubricate
		Failed sealing of the O-ring (62)	Clean and replace if needed
	SAFETY VALVE VS/FI	Die	Check and clean if necessary
	VALVE 3/2	Outer O-rings (46) not sealing	Clean and replace if needed
		Failed sealing of the O-ring (47)	Clean and replace if needed
		Failed sealing of the O-ring (48)	Clean and replace if needed
		Pad (16) dirty or damaged	Clean and replace if needed
	SLAM-SHUT VALVE HB/97 BUILT-INSLAM- SHUT VALVE	Stem (6) with friction	Clean and lubricate
Plug (71) with friction		Clean and lubricate	
VALVE 3/2	Failed sealing of the balancing piston O-ring (36)	Clean and replace if needed	
	Gasket (16) locked	Clean and replace if needed	
	Clogged vents	Check and clean if necessary	

Failure	Device	Possible causes	Intervention
<b>Failure to provide service</b>	SLAM-SHUT VALVE HB/97 BUILT-INSLAM- SHUT VALVE	Stem (6) locked in opening position	Clean and lubricate
		Plug (71) locked in opening position	Clean and lubricate
		die O-ring (36)	Clean and replace if needed
		I/DWR ring (64) damaged	replace
	PRESSURE SWITCHES MODELS 101 ÷ 105	Breaking Diaphragm rupture (43) if there is no min. spring.	Replace
		Locked lever mechanisms	Check and if necessary clean and lubricate
	VALVE 3/2	Pin (6) locked	Check and if necessary clean and lubricate
		Lip pad (16) locked	Clean and replace if needed
		Clogged vents	Check and clean if needed

Failure	Device	Possible causes	Intervention
<b>Unintentional intervention</b>	SLAM-SHUT VALVE HB/97 BUILT-INSLAM-SHUT VALVE	Failed sealing of the O-ring (40)	Clean and replace if needed
		Failed sealing of the lower O-ring (36)	Clean and replace if needed
		Failed sealing of the O-ring (39)	Clean and replace if needed
		Failed sealing of the U-ring (63)	Clean and replace if needed
		Failed sealing of the O-ring (43)	Clean and replace if needed
		Failed sealing of the upper O-ring (62)	Clean and replace if needed
		Failed sealing of the O-ring (42)	Clean and replace if needed
	PRESSURE REGULATOR R44/SS	Lower diaphragm (16) not sealing	Clean and replace if needed
		Failed sealing of the O-ring (28)	Clean and replace if needed
		Failed sealing of the O-ring (29)	Clean and replace if needed
		Failed sealing of the O-ring (26.1)	Clean and replace if needed
	SAFETY VALVE VS/FI	Lack of Pad seal (3)	Clean and replace if needed
	VALVE 3/2	Gasket (16) locked	Clean and replace if needed
		Outer O-rings (46) not sealing	Clean and replace if needed
Failed sealing of the O-ring (47)		Clean and replace if needed	
Failed sealing of the O-ring (48)		Clean and replace if needed	
<b>Downstream pressure increase with slam-shut device shutting off</b>	SLAM-SHUT VALVE HB/97 BUILT-INSLAM-SHUT VALVE	Reinforced gasket (8) dirty or damaged	Clean and replace if needed
		Failed sealing of the O-ring (39)	Clean and replace if needed
		Plug profile (71) damaged	Replace
		Failed sealing of the O-ring (88)	Clean and replace if needed
		Failed sealing of the O-ring (87)	Clean and replace if needed
	BYPASS DEVICE HP2/2	Failed sealing of the O-ring (21)	Clean and replace if needed
		Damaged seat profile (6)	Replace
		Pad (12) dirty or damaged	Clean and replace if needed
		Failed sealing of the O-ring (24)	Clean and replace if needed

*Tab. 10.158*

## 11 - UNINSTALLATION AND DISPOSAL

### 11.1 - GENERAL SAFETY WARNINGS

#### HAZARD!



Make sure that there are no ignition sources in the work area set up to uninstall and/or dispose of the equipment.

#### WARNING!

Before proceeding with uninstallation and disposal, make the equipment safe by disconnecting it from any power supply.

### 11.2 - QUALIFICATION OF THE OPERATORS IN CHARGE

#### Commissioning

Operator qualification	Installer
PPE required	 <p> <b>WARNING!</b></p> <p>The PPE listed in this table is related to the risk associated with the equipment. For the required PPE to protect against risks associated with the workplace, installation or operating conditions, please refer to:</p> <ul style="list-style-type: none"> <li>• the regulations in force in the country of installation;</li> <li>• any information provided by the Safety Manager at the installation facility.</li> </ul>
Equipment required	Please refer to the chapter "7 - Commissioning/maintenance equipment".

Tab. 11.159

### 11.3 - UNINSTALLATION

#### WARNING!

Before any intervention, it is necessary:

- to ensure that the line on which the equipment is installed is shut off upstream and downstream;
  - to operate the slam shut valve in manual mode by pressing the release button (Pos. 10 - Figure 4.11.).
- Next, check that the pressure indicated by the pressure gauge installed on the LINE OFF 2.0 device (Pos. 7.3 - Figure 8.31.) is 0 bar, ensuring complete depressurisation of the line.

#### NOTICE!

For equipment uninstallation procedures, please refer to the installation procedures (see chapter "6 - installation"), proceeding in reverse order.

### 11.4 - INFORMATION REQUIRED IN CASE OF RE-INSTALLATION

**! NOTICE!**

Should the equipment be reused after uninstallation, please refer to Chapter:

- “6 - installation”;
- “8 - Commissioning”.

## 11.5 - DISPOSAL INFORMATION

**! NOTICE!**

**Bear in mind that the laws in force in the country where the system is installed must be complied with. Illegal or incorrect disposal involves the application of the penalties provided for by the regulations in force in the country of installation.**

**! NOTICE!**

**Proper disposal prevents damage to man and the environment and promotes the reuse of precious raw materials.**

The equipment was manufactured with materials that can be recycled by specialised companies. To dispose of the equipment correctly, proceed as indicated in “Tab. 11.160”:

Step	Action
1	Set up a large work area free from obstacles where to safely dismantle the equipment.
2	Sort the various components by type of material for easier recycling through separate collection.
3	Send the materials obtained in <b>Step 2</b> to a specialised company.

*Tab. 11.160*

The equipment in any possible configuration consists of the following materials:

Material	Disposal/recycling indications
<b>Plastic</b>	It must be dismantled and disposed of separately.
<b>Lubricants/Oils</b>	They must be collected and delivered to the appropriate specialized and authorized collection and disposal centres.
<b>Iron</b>	Disassemble and collect separately. It must be recycled through the specific collection centres.
<b>Steel</b>	Disassemble and collect separately. It must be recycled through the specific collection centres.
<b>Aluminium</b>	Disassemble and collect separately. It must be recycled through the specific collection centres.
<b>Pneumatic/electric components</b>	They must be dismantled in order to be reused if they are still in good condition or, if possible, overhauled and recycled.

*Tab. 11.161*

**! NOTICE!**

**Please refer to the chapter “9 - Maintenance and functional checks” to better identify the composition of the equipment and its parts.**

## 12 - RECOMMENDED SPARE PARTS

### 12.1 - GENERAL WARNINGS

#### NOTICE!

If spare parts not marked are used, PIETRO FIORENTINI S.p.A. their declared performance cannot be guaranteed.

It is recommended to use original spare parts PIETRO FIORENTINI S.p.A.

PIETRO FIORENTINI S.p.A. shall not be held liable for any damage caused by using non-original parts..

### 12.2 - HOW TO REQUEST SPARE PARTS

#### NOTICE!

For specific information, please refer to the sales network of PIETRO FIORENTINI S.p.A.

PAGE INTENTIONALLY LEFT BLANK

## 13 - CALIBRATION TABLES

### 13.1 - 300 SERIES PILOT CALIBRATION TABLES

302/A							
Pos.	Spring item code	Spring colour	d	Lo	De	Min.	Max
1	2701800	Yellow	4.5	100	35	0.8	1.1
2	2702080	Orange	5			1.201	2,2
3	2702290	Red	5.5			2,201	3,5
4	2702460	Green	6			3,501	5,6
5	2702660	Black	6.5			5,601	7,3

**d** = Wire Diameter (mm)    **Lo** = Spring Length (mm)    **De** = External Diameter (mm)

Tab. 13.162

304/A							
Pos.	Spring item code	Spring colour	d	Lo	De	Min.	Max
4	2702290	Red	5.5	100	35	7	10
5	2702460	Green	6			10,001	15
6	2702660	Black	6.5			15,001	22
7	2702820	Blue	7			22,001	33
8	2703045	Brown	7,5			33,001	43

**d** = Wire Diameter (mm)    **Lo** = Spring Length (mm)    **De** = External Diameter (mm)

Tab. 13.163

305/A							
Pos.	Spring item code	Spring colour	d	Lo	De	Min.	Max
7	2702820	Blue	7	100	35	22,001	33
8	2703045	Brown	7,5			33,001	42
9	2703224	Grey	8			42,001	60

**d** = Wire Diameter (mm)    **Lo** = Spring Length (mm)    **De** = External Diameter (mm)

Tab. 13.164

## 13.2 - 200 SERIES PILOT CALIBRATION TABLES

The PM/819 monitor uses pilots 204/A, 205/A and 207/A.

The adjustment ranges of the different pilots are shown in the following tables:

Pilot 204/A							
Pos.	Spring item code	Spring colour	d	Lo	De	Min.	Max
1	2701260	White	3,5	60	35	0.3	1
2	2701530	Yellow	4			1,001	2
3	2702070	Orange	5			2.001	6
4	2702450	Red	6			6,001	12
5	2702815	Green	7			12.001	18
6	2703220	Black	8			18.001	28
7	2703420	Blue	8,5			28.001	43

**d** = Wire Diameter (mm)    **Lo** = Spring Length (mm)    **De** = External Diameter (mm)

Tab. 13.165

Pilot 205/A							
Pos.	Spring item code	Spring colour	d	Lo	De	Min.	Max
1	2702820	Blue	7	100	35	20	30
2	2703045	Brown	7,5			30.001	44
3	2703224	Grey	8			44.001	60

**d** = Wire Diameter (mm)    **Lo** = Spring Length (mm)    **De** = External Diameter (mm)

Tab. 13.166

Pilot 207/A							
Pos.	Spring item code	Spring colour	d	Lo	De	Min.	Max
1	2703224	Grey	8	100	35	41	74

**d** = Wire Diameter (mm)    **Lo** = Spring Length (mm)    **De** = External Diameter (mm)

Tab. 13.167

Pre-regulator R14/A							
Pos.	Spring item code	Spring colour	d	Lo	De	Min.	Max
1	2700525	Orange	2	40	22	0,65	2,15
2	2700645	Red	2.3			1,25	2.8
3	2700775	Green	2.5			1.95	3,6

**d** = Wire Diameter (mm)    **Lo** = Spring Length (mm)    **De** = External Diameter (mm)    **Min./Max.** = pressure (bar)

Tab. 13.168.

### 13.3 - CALIBRATION TABLES FOR PRESSURE SWITCHES MOD. 100

Below are the calibration tables for the pressure switches that may be installed in the built-in slam-shut valves:

Mod. 102M/102MH - Max pressure							
Pos.	Spring item code	Spring colour	d	Lo	De	Min.	Max
1	2701260	White	3,5	60	35	0,2	0.8
2	2701530	Yellow	4			0.801	1,6
3	2701790	Yellow/black	4.5			1,601	2.6
4	2702280	White/red	5.5			2,601	5.5
<b>d = Wire Diameter (mm)   Lo = Spring Length (mm)   De = External Diameter (mm)</b>							

Tab. 13.169

Mod. 102M - Min pressure							
Pos.	Spring item code	Spring colour	d	Lo	De	Min.	Max
1	2700513	Red	2	40	15	0,05	0,199
2	2700713	Green	2.3			0,2	0,4
3	2700750	Black	2.5			0.401	0.8
4	2700985	Brown	3			0.801	2.8
<b>d = Wire Diameter (mm)   Lo = Spring Length (mm)   De = External Diameter (mm)</b>							

Tab. 13.170

Mod. 102MH - Min pressure							
Pos.	Spring item code	Spring colour	d	Lo	De	Min.	Max
1	2700985	Brown	3	40	15	2.8	4,2
	2700980	Blue	3	35			
2	2700985	Brown	3	40		4,201	5.5
	2700985	Brown	3				
<b>d = Wire Diameter (mm)   Lo = Spring Length (mm)   De = External Diameter (mm)</b>							

Tab. 13.171

Mod. 103M/103MH - Max pressure							
Pos.	Spring item code	Spring colour	d	Lo	De	Min.	Max
1	2701530	Yellow	4	60	35	2	4
2	2701790	Yellow/black	4.5	60		4.001	7,5
3	2702280	White/red	5.5	60		7.501	15
4	2702450	Red	6	60		15.001	22
<b>d = Wire Diameter (mm)   Lo = Spring Length (mm)   De = External Diameter (mm)</b>							

Tab. 13.172

**Mod. 103M - Min pressure**

Pos.	Spring item code	Spring colour	d	Lo	De	Min.	Max
1	2700464	Orange	1,7	40	15	0,2	0,5
2	2700513	Red	2			0,501	0,8
3	2700713	Green	2,3			0,801	1,7
4	2700750	Black	2,5			1,701	4
5	2700985	Brown	3			4.001	8

**d** = Wire Diameter (mm)    **Lo** = Spring Length (mm)    **De** = External Diameter (mm)

*Tab. 13.173*
**Mod. 103MH - Min pressure**

Pos.	Spring item code	Spring colour	d	Lo	De	Min.	Max
1	2700985	Brown	3	40	15	8	13
	2700980	Blue	3	35			
2	2700985	Brown	3	40	15	13.001	19
	2700985	Brown	3				

**d** = Wire Diameter (mm)    **Lo** = Spring Length (mm)    **De** = External Diameter (mm)

*Tab. 13.174*
**Mod. 104M/104MH - Max pressure**

Pos.	Spring item code	Spring colour	d	Lo	De	Min.	Max
1	2702280	White/Red	5,5	60	35	15.001	30
2	2702450	Red	6	60		30.001	45

**d** = Wire Diameter (mm)    **Lo** = Spring Length (mm)    **De** = External Diameter (mm)

*Tab. 13.175*
**Mod. 104M - Min pressure**

Pos.	Spring item code	Spring colour	d	Lo	De	Min.	Max
1	2700713	Green	2,3	40	15	1,6	3
2	2700750	Black	2,5			3,001	8
3	2700985	Brown	3			8,001	18

**d** = Wire Diameter (mm)    **Lo** = Spring Length (mm)    **De** = External Diameter (mm)

*Tab. 13.176*
**Mod. 104MH - Min pressure**

Pos.	Spring item code	Spring colour	d	Lo	De	Min.	Max
1	2700985	Brown	3	40	15	18	30
	2700980	Blue	3	35			
2	2700985	Brown	3	40		15	30.001
	2700985	Brown	3				

**d** = Wire Diameter (mm)    **Lo** = Spring Length (mm)    **De** = External Diameter (mm)

*Tab. 13.177*

**Mod. 105M/105MH - Max pressure**

Pos.	Spring item code	Spring colour	d	Lo	De	Min.	Max
1	2702280	White/Red	5.5	60	35	30	65
2	2702450	Red	6	60		65.001	90

**d** = Wire Diameter (mm)    **Lo** = Spring Length (mm)    **De** = External Diameter (mm)

*Tab. 13.178*
**Mod. 105M - Min pressure**

Pos.	Spring item code	Spring colour	d	Lo	De	Min.	Max
1	2700713	Green	2.3	40	15	3	7
2	2700750	Black	2.5			7.001	16
3	2700985	Brown	3			16.001	44

**d** = Wire Diameter (mm)    **Lo** = Spring Length (mm)    **De** = External Diameter (mm)

*Tab. 13.179*
**Mod. 105MH - Min pressure**

Pos.	Spring item code	Spring colour	d	Lo	De	Min.	Max	
1	2700985	Brown	3	40	15	44	60	
	2700980	Blue	3	35				
2	2700985	Brown	3	40		15	60.001	90
	2700985	Brown	3					

**d** = Wire Diameter (mm)    **Lo** = Spring Length (mm)    **De** = External Diameter (mm)

*Tab. 13.180*

### 13.4 - M/A ACCELERATOR VALVE CALIBRATION TABLES

M/A							
Pos.	Spring item code	Spring colour	d	Lo	De	Min.	Max
1	2701260	White	3.5	60	35	0.3	1
2	2701530	Yellow	4			1,001	2,1
3	2702070	Orange	5			2,101	5.5
4	2702450	Red	6			5,501	11
5	2702815	Green	7			11.001	20

**d** = Wire Diameter (mm)    **Lo** = Spring Length (mm)    **De** = External Diameter (mm)

Tab. 13.181

M/A 1							
Pos.	Spring item code	Spring colour	d	Lo	De	Min.	Max
1	2702820	Blue	7	100	35	20	33
2	2703045	Brown	7,5			33,001	43
3	2703224	Grey	8			43.001	63

**d** = Wire Diameter (mm)    **Lo** = Spring Length (mm)    **De** = External Diameter (mm)

Tab. 13.182

M/A 2							
Pos.	Spring item code	Spring colour	d	Lo	De	Min.	Max
1	2703224	Grey	8	100	35	40	75

**d** = Wire Diameter (mm)    **Lo** = Spring Length (mm)    **De** = External Diameter (mm)

Tab. 13.183

PAGE INTENTIONALLY LEFT BLANK

TM002ENG

