

ASX 176

High medium pressure gas regulator

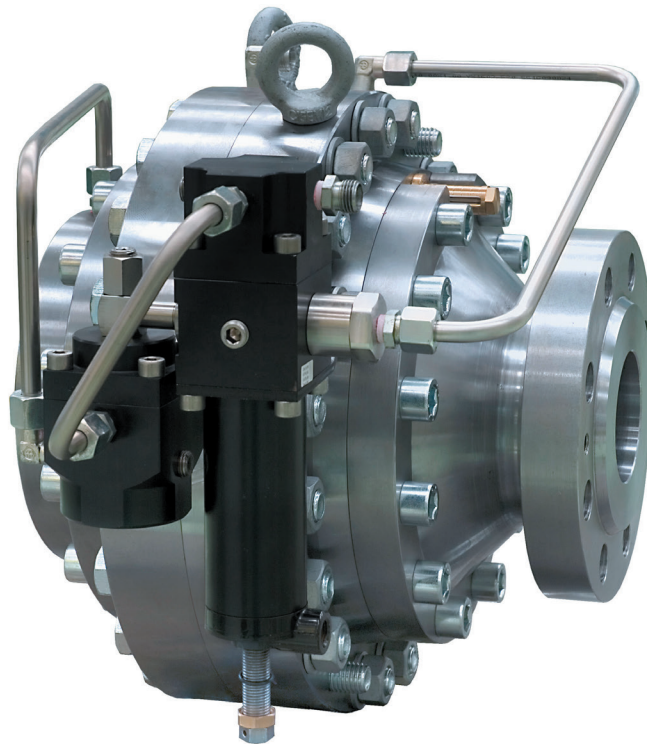

Revision D - Edition 02/2026

**USER, MAINTENANCE
AND WARNING MANUAL**

PAGE INTENTIONALLY LEFT BLANK

1 - INTRODUCTION

FOREWORD

All rights reserved. No part of this publication may be reproduced, distributed, translated into other languages or transmitted by any electronic or mechanical media, including photocopies, recording or any other storage and retrieval system, for any other purposes that are not exclusively the personal use of the buyer, without the express written permission of the Manufacturer.

The manufacturer is in no way responsible for the consequences of operations carried out in a manner not in accordance with the manual.

GENERAL REMARKS

All operating, maintenance instructions and recommendations described in this manual must be observed. In order to obtain the best performance and to keep the equipment in efficient condition, the manufacturer recommends that maintenance operations be carried out regularly.

It is of particular importance that the personnel responsible for the equipment be trained in its use, maintenance and application of the safety instructions and procedures indicated in this manual.

Revision: D

PAGE INTENTIONALLY LEFT BLANK

1.1 - REVISION HISTORY

Revision index	Date
A	12/2021
B	01/2024
C	11/2024
D	02/2026

Tab. 1.1.

INDEX

1 - INTRODUCTION	3
1.1 - REVISION HISTORY.....	5
2 - GENERAL INFORMATION	11
2.1 - MANUFACTURER IDENTIFICATION	11
2.2 - IDENTIFICATION OF THE PRODUCT	11
2.3 - REGULATORY FRAMEWORK.....	11
2.4 - WARRANTY	11
2.5 - SYMBOLS USED IN THE MANUAL.....	12
2.6 - ADDRESSEES, SUPPLY AND STORAGE OF THE MANUAL	13
2.7 - LANGUAGE	13
2.8 - APPLIED RATING PLATES	14
2.8.1 - GLOSSARY FOR RATING PLATES.....	16
2.9 - GLOSSARY OF UNITS OF MEASUREMENT	18
2.10 - QUALIFIED PROFESSIONAL FIGURES	19
3 - SAFETY	21
3.1 - GENERAL SAFETY WARNINGS.....	21
3.2 - PERSONAL PROTECTIVE EQUIPMENT.....	22
3.3 - RESIDUAL RISKS	23
3.3.1 - TABLE SHOWING RESIDUAL RISKS DUE TO PRESSURE	24
3.3.2 - TABLE OF RESIDUAL RISKS FOR POTENTIALLY EXPLOSIVE ATMOSPHERES	26
3.4 - OBLIGATIONS AND PROHIBITIONS	28
3.5 - SAFETY PICTOGRAMS	29
3.6 - NOISE LEVEL	29

4 - DESCRIPTION AND OPERATION 31

4.1 - GENERAL DESCRIPTION	31
4.1.1 - REGULATOR REACTION MODES.....	32
4.2 - OPERATION.....	32
4.3 - DESIGNED USE.....	34
4.3.1 - INTENDED USE	34
4.3.2 - REASONABLY FORESEEABLE MISUSE	34
4.3.3 - TYPES OF FLUIDS	34
4.4 - TECHNICAL FEATURES/PERFORMANCE	35
4.5 - POSSIBLE CONFIGURATIONS	36
4.5.1 - BUILT-IN SILENCER.....	37
4.5.2 - MONITOR	38
4.5.2.1 - BUILT-IN MONITOR	38
4.5.2.2 - M/A ACCELERATING VALVE	44
4.5.3 - SLAM-SHUT VALVE	45
4.5.3.1 - BUILT-IN SLAM-SHUT VALVE SSX/176	45
4.5.4 - SLAM-SHUT VALVE PRESSURE SWITCHES.....	48

5 - TRANSPORT AND HANDLING 51

5.1 - SPECIFIC WARNINGS FOR TRANSPORT AND HANDLING	51
5.1.1 - PACKAGING AND FASTENERS USED FOR TRANSPORT	52
5.2 - PHYSICAL CHARACTERISTICS OF THE EQUIPMENT	54
5.2.1 - ASX 176 (+LDB/176).....	54
5.2.2 - ASX 176 + PM/176	55
5.2.3 - ASX 176 + SSX/176.....	56
5.3 - EQUIPMENT ANCHORING AND LIFTING METHOD.....	58
5.3.1 - FORKLIFT HANDLING METHOD.....	59
5.3.2 - CRANE HANDLING METHOD.....	61
5.4 - PACKAGING REMOVAL.....	62
5.4.1 - PACKAGING DISPOSAL	62
5.5 - STORAGE AND ENVIRONMENTAL CONDITIONS	63
5.5.1 - PRE-INSTALLATION WARNINGS AFTER PROLONGED STORAGE	63

6 - INSTALLATION 65

6.1 - INSTALLATION PRE-REQUISITES.....	65
6.1.1 - ENVIRONMENTAL CONDITIONS ALLOWED.....	65
6.1.2 - CHECKS BEFORE INSTALLATION.....	66
6.2 - SPECIFIC SAFETY INSTRUCTIONS FOR THE INSTALLATION PHASE	67
6.3 - GENERAL INFORMATION ON CONNECTIONS	68
6.4 - REGULATOR INSTALLATION POSITIONS.....	69
6.5 - EQUIPMENT INSTALLATION PROCEDURE	70
6.5.1 - IN-LINE EQUIPMENT INSTALLATION PROCEDURE	70
6.5.2 - INSTALLATION PROCEDURE FOR IN-LINE EQUIPMENT WITH SPACER	71
6.5.3 - CONNECTION OF THE SENSING LINES TO THE DOWNSTREAM PIPING.....	73
6.6 - POST-INSTALLATION AND PRE-COMMISSIONING CHECKS	75

7 - COMMISSIONING/MAINTENANCE EQUIPMENT..... 77

7.1 - LIST OF EQUIPMENT.....	77
7.2 - EQUIPMENT NEEDED FOR THE DIFFERENT CONFIGURATIONS	78

8 - COMMISSIONING 81

8.1 - GENERAL WARNINGS	81
8.1.1 - SAFETY REQUIREMENTS FOR COMMISSIONING	81
8.2 - PRELIMINARY PROCEDURES FOR COMMISSIONING	82
8.3 - PROPER COMMISSIONING CHECK	83
8.4 - CALIBRATION OF ANY ACCESSORIES.....	83
8.5 - REGULATOR COMMISSIONING PROCEDURE	84
8.6 - COMMISSIONING PROCEDURE FOR THE ASX 176 REGULATOR WITH BUILT-IN MONITOR PM/176..	86
8.7 - COMMISSIONING PROCEDURE FOR THE ASX 176 REGULATOR WITH BUILT-IN PM/176 MONITOR AND M/A ACCELERATING VALVE	88
8.8 - COMMISSIONING PROCEDURE FOR THE ASX 176 REGULATOR WITH BUILT-IN SSX/176 SLAM-SHUT VALVE.....	90
8.8.1 - CHECKING THE SSX/176 SLAM-SHUT VALVE FOR PROPER SEALING DURING SHUT-OFF	90
8.8.2 - LINE OFF 2.0 COMMISSIONING AND CALIBRATION PROCEDURE FOR SSX/176 BUILT-IN SLAM-SHUT VALVE	92
8.8.3 - PRESSURE SWITCH CALIBRATION PROCEDURE FOR LINE OFF 2.0 MOD. 100.....	94
8.9 - DEVICE CALIBRATION.....	96
8.9.1 - CALIBRATION OF 200/A SERIES PILOTS	96
8.9.2 - CALIBRATION OF PRESSURE SWITCHES MOD. 100.....	97

9 - MAINTENANCE AND FUNCTIONAL CHECKS..... 99

9.1 - GENERAL WARNINGS	99
9.2 - PERIODICALLY CHECKING AND INSPECTING THE EQUIPMENT FOR PROPER OPERATION.....	101
9.3 - ROUTINE MAINTENANCE	102
9.3.1 - GENERAL SAFETY WARNINGS.....	102
9.3.2 - REPLACEMENT FREQUENCY FOR COMPONENTS SUBJECT TO WEAR	103
9.4 - ROUTINE MAINTENANCE PROCEDURES.....	105
9.4.1 - TIGHTENING TORQUES ASX 176	106
9.4.2 - REPLACING ELEMENTS SUBJECT TO WEAR AND ABRASION.....	125
9.4.3 - REGULATOR MAINTENANCE PROCEDURE ASX 176.....	126
9.4.4 - MAINTENANCE PROCEDURE REGULATOR ASX 176 WITH SILENCER LDB/176.....	142
9.4.5 - MAINTENANCE PROCEDURE FOR BUILT-IN MONITOR PM/176 OR BUILT-IN SLAM-SHUT VALVE SSX/176.....	158
9.4.6 - PILOT MAINTENANCE PROCEDURE 200/A SERIES + PRE-REGULATOR R14/A	174
9.4.7 - M/A ACCELERATING VALVE MAINTENANCE PROCEDURE.....	190
9.4.8 - MAINTENANCE PROCEDURE FOR PRESSURE SWITCHES MOD. 100.....	194
9.4.9 - LINE OFF 2.0 MAINTENANCE PROCEDURE	206
9.4.10 - PROCEDURE FOR RECOMMISSIONING AFTER MAINTENANCE	231

10 - TROUBLESHOOTING..... 233

10.1 -GENERAL WARNINGS	233
10.2 -OPERATOR QUALIFICATION SPECIFICATION.....	234
10.3 -TROUBLESHOOTING PROCEDURES	234
10.4 -TROUBLESHOOTING TABLES	235
10.4.1 - TROUBLESHOOTING ASX 176 REGULATOR.....	235
10.4.2 - TROUBLESHOOTING OF SILENCER LDB/176	237
10.4.3 - MONITOR PM/176 TROUBLESHOOTING.....	238
10.4.4 - TROUBLESHOOTING OF THE SSX/176 SLAM-SHUT VALVE AND LINE OFF 2.0 DEVICE.....	240

11 - UNINSTALLATION AND DISPOSAL	243
11.1 -GENERAL SAFETY WARNINGS.....	243
11.2 -QUALIFICATION OF THE OPERATORS IN CHARGE.....	243
11.3 -UNINSTALLATION.....	243
11.4 -INFORMATION REQUIRED IN CASE OF RE-INSTALLATION.....	244
11.5 -DISPOSAL INFORMATION.....	244
12 - RECOMMENDED SPARE PARTS	245
12.1 -GENERAL WARNINGS	245
12.2 -HOW TO REQUEST SPARE PARTS.....	245
13 - CALIBRATION TABLES	247
13.1 -200/A AND 210/A SERIES PILOT CALIBRATION TABLES	247
13.2 -CALIBRATION TABLES FOR PRESSURE SWITCHES MOD. 100.....	248
13.3 -M/A ACCELERATOR VALVE CALIBRATION TABLES.....	251

2 - GENERAL INFORMATION

2.1 - MANUFACTURER IDENTIFICATION

Manufacturer	PIETRO FIORENTINI S.P.A.
Address	Via Enrico Fermi, 8/10 36057 Arcugnano (VI) - ITALY Tel. +39 0444 968511 Fax +39 0444 960468 www.fiorentini.com sales@fiorentini.com

Tab. 2.2.

2.2 - IDENTIFICATION OF THE PRODUCT

Equipment	HIGH PRESSURE REGULATOR
Model	ASX 176

Tab. 2.3.

2.3 - REGULATORY FRAMEWORK

PIETRO FIORENTINI S.P.A., with registered offices in Arcugnano (Italy) - Via E. Fermi, 8/10, declares that the equipment of the ASX 176 series described in this instruction manual was designed, manufactured, tested and checked in compliance with the requirements of the EN 334 standard on gas pressure regulators.

The equipment meets the requirements of Directive 2014/68/EU (Pressure Equipment Directive PED). The assessment procedure adopted is in accordance with module H1 as per Annex III of the Directive.

NOTICE!

The declaration of conformity in its original version is delivered together with the equipment.

2.4 - WARRANTY

PIETRO FIORENTINI S.P.A. guarantees that the equipment was manufactured using the best materials, with high quality workmanship, and complies with the quality requirements, specifications and performance set out in the order.



The warranty shall be considered null and void and PIETRO FIORENTINI S.P.A. shall not be liable for any damage and/or malfunctions:

- due to any acts or omissions of the purchaser or end-user, or any of their carriers, employees, agents, or any third party or entity;
- in the event that the purchaser, or a third party, makes changes to the equipment supplied by PIETRO FIORENTINI S.P.A. without the prior written approval of the latter;
- in the event of failure by the purchaser to comply with the instructions contained in these instructions, as provided by PIETRO FIORENTINI S.P.A..

NOTICE!

The warranty conditions are specified in the commercial contract.

2.5 - SYMBOLS USED IN THE MANUAL

Symbol	Definition
	Symbol used to identify important warnings for the safety of the operator and/or equipment.
	Symbol used to identify information of particular importance in the manual. The information may also concern the safety of the personnel involved in using the equipment.
	Obligation to consult the instruction manual/booklet. Indicates a requirement for the personnel to refer to (and understand) the operating and warning instructions of the machine before working with or on it.

Tab. 2.4.

HAZARD!

Alerts to a hazard with a high level of risk, an imminent hazardous situation which, if not prevented, will result in death or severe damage.

WARNING!

Alerts to a hazard with a medium level of risk, a potentially hazardous situation which, if not prevented, may result in death or severe damage.

ATTENTION!

Alerts to a hazard with a low level of risk, a potentially hazardous situation which, if not prevented, could result in minor or moderate damage.

NOTICE!

Alerts to specific warnings, directions or notes of particular concern, that are not related to physical injury, as well as practices for which physical injury is not likely to occur.

2.6 - ADDRESSEES, SUPPLY AND STORAGE OF THE MANUAL

The instruction manual is intended for qualified operator responsible for using and managing the equipment throughout its service life.

It contains the necessary information to properly use the equipment and keep its functional and qualitative characteristics unchanged over time. All information and warnings for safe, correct use are also provided.

The manual, as well as the declaration of conformity and/or test certificate, is an integral part of the equipment and must always accompany it whenever it is moved or resold. It is up to the user to keep this documentation intact for reference throughout the lifespan of the equipment.

WARNING!

Removing, rewriting or editing the pages of the manual and their contents is not allowed.

Keep the instruction manual near the equipment, in an accessible place known by all qualified technicians involved in using and running it.

PIETRO FIORENTINI S.p.A. shall not be held liable for any damage to people, animals and property caused by failure to adhere to the warnings and operating procedures described in this manual.

The original manual has been drawn up in Italian.

Any translations into additional languages are to be made from the original instructions.

2.7 - LANGUAGE

The original manual has been drawn up in Italian.

Any translations into additional languages are to be made from the original instruction manual.

HAZARD!

The translations into other languages cannot be fully verified. If any inconsistency is found, please refer to the text of the original manual.

If inconsistencies are found or the text does not make sense:

- **stop any actions;**
- **contact immediately PIETRO FIORENTINI S.p.A. at the addresses given in paragraph 2.1 ("Manufacturer identification").**

WARNING!

XX shall be held liable only for the information provided in the original instruction manual.

2.8 - APPLIED RATING PLATES



WARNING!

**Removing rating plates and/or replacing them with other plates is strictly not allowed.
Should the plates be unintentionally damaged or removed, the customer must notify
PIETRO FIORENTINI S.p.A.**

The equipment and its accessories are provided with nameplates (from Id.1 to Id.8).

The plates specify identification details of the equipment and its accessories to be provided, if necessary, to PIETRO FIORENTINI S.p.A.

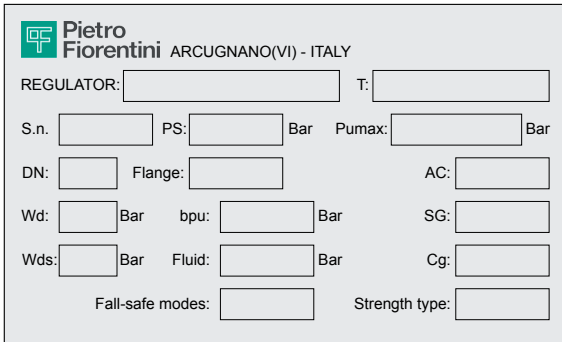
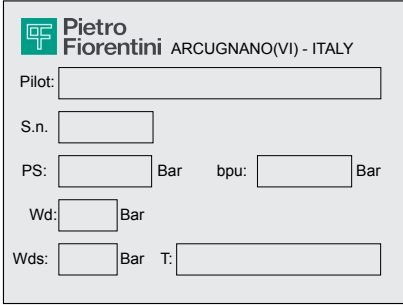
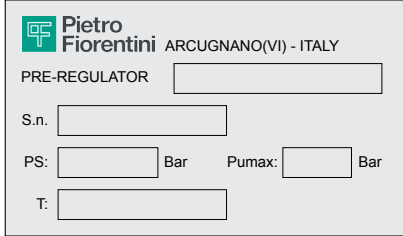
Tab. 2.5 shows the rating plates applied:

Id.	Type	Image
1	RATING PLATE REGULATOR (EC version)	
2	RATING PLATE PILOT	
3	RATING PLATE PRE-REGULATOR	
4	RATING PLATE SILENCER	

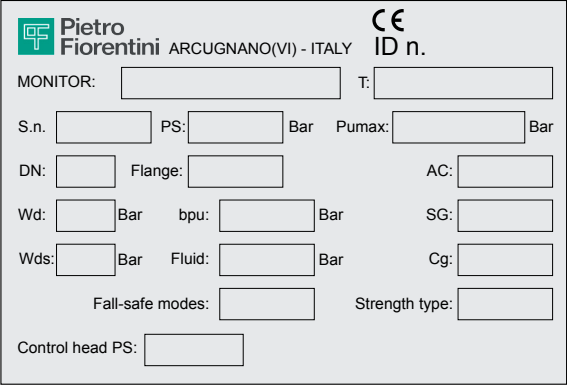
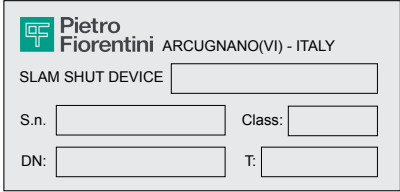
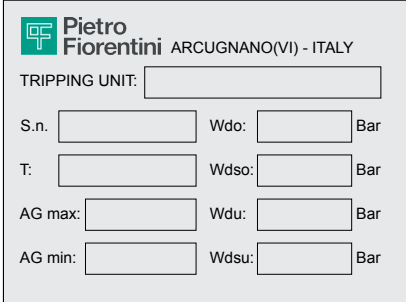
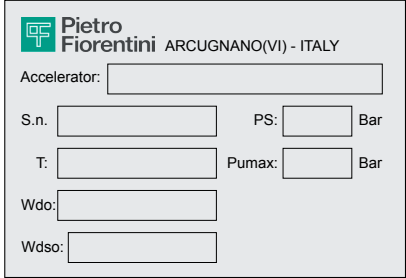
Id.	Type	Image
5	RATING PLATE MONITOR	 <p> Pietro Fiorentini ARCUGNANO(VI) - ITALY CE ID n. MONITOR: <input type="text"/> T: <input type="text"/> S.n. <input type="text"/> PS: <input type="text"/> Bar Pmax: <input type="text"/> Bar DN: <input type="text"/> Flange: <input type="text"/> AC: <input type="text"/> Wd: <input type="text"/> Bar bpu: <input type="text"/> Bar SG: <input type="text"/> Wds: <input type="text"/> Bar Fluid: <input type="text"/> Bar Cg: <input type="text"/> Fall-safe modes: <input type="text"/> Strength type: <input type="text"/> Control head PS: <input type="text"/> </p>
6	RATING PLATE SLAM-SHUT VALVE	 <p> Pietro Fiorentini ARCUGNANO(VI) - ITALY SLAM SHUT DEVICE <input type="text"/> S.n. <input type="text"/> Class: <input type="text"/> DN: <input type="text"/> T: <input type="text"/> </p>
7	RATING PLATE PRESSURE SWITCH	 <p> Pietro Fiorentini ARCUGNANO(VI) - ITALY TRIPPING UNIT: <input type="text"/> S.n. <input type="text"/> Wdo: <input type="text"/> Bar T: <input type="text"/> Wdso: <input type="text"/> Bar AG max: <input type="text"/> Wdu: <input type="text"/> Bar AG min: <input type="text"/> Wdsu: <input type="text"/> Bar </p>
8	RATING PLATE ACCELERATOR VALVE	 <p> Pietro Fiorentini ARCUGNANO(VI) - ITALY Accelerator: <input type="text"/> S.n. <input type="text"/> PS: <input type="text"/> Bar T: <input type="text"/> Pmax: <input type="text"/> Bar Wdo: <input type="text"/> Wdso: <input type="text"/> </p>

Tab. 2.5.

2.8.1 - GLOSSARY FOR RATING PLATES

The terms and abbreviations used on rating plates are described in Tab. 2.6:

Term	Description
AC	Accuracy class.
AG max	Slam-shut valve accuracy class due to pressure increase. "OPSO" (Over pressure shut off).
AG min	Slam-shut valve accuracy class due to pressure decrease. "UPSO" (Under pressure shut off).
bpu	Range of inlet pressure for which the regulator ensures a given accuracy class.
CE	Marking certifying compliance with applicable European directives.
Cg	Flow rate coefficient.
Class	Alphanumeric designation used for reference purposes related to a combination of mechanical and dimensional characteristics for flanges, in accordance with the relevant parts of EN 1759 series, which includes the word Class followed by a dimensionless whole number.
Control head PS	Maximum permissible monitor head pressure.
DN	Nominal size of connections.
Fail safe mode	Regulator reaction mode (Fail open or Fail close).
Flange	Type of flanged connections or type of connection thread.
Fluid	Type of fluid compatible with the equipment.
ID n.	Number of the Notified Body participating in the conformity assessment of the equipment.
Monitor	Monitor family.
Pilot	Pilot family.
PS	Maximum permissible pressure for which the equipment was designed.
Pumax	Maximum inlet pressure at which the regulator can operate continuously under specific conditions.
REGULATOR	Equipment family.
SG	Shut-off pressure class.
Slam-shut device	Slam-shut valve family.
S.n.	Equipment serial number.
Strength type	Strength class: Integral strength (IS) or differential strength (DS).
T	Permissible temperature range (min. and max.) that the equipment was designed for.
Tripping unit	Pressure switch family.
Type	Accessory type and family.
Wd	Full setpoint range that can be obtained from the regulator by adjusting and/or replacing certain components (e.g. replacement of valve seat or control element, e.g. spring).
Wdo	Full setpoint range with regard to tripping caused by increased pressure in the pressure switch built into the slam-shut valve. This range can be obtained by adjusting and/or replacing the components (for example, spring or sensitive element).
Wds	Full setpoint range that can be obtained from the regulator by adjusting but not replacing the components.
Wdso	Full setpoint range with regard to tripping caused by increased pressure in the pressure switch built into the slam-shut valve. This range can be obtained by adjusting but not replacing the components.

Term	Description
Wdu	Full setpoint range with regard to tripping caused by decreased pressure in the pressure switch built into the slam-shut valve. This range can be obtained by adjusting and/or replacing the components (for example, spring or sensitive element).
Wdsu	Full setpoint range with regard to tripping caused by decreased pressure in the pressure switch built into the slam-shut valve. This range can be obtained by adjusting but not replacing the components.

Tab. 2.6.

2.9 - GLOSSARY OF UNITS OF MEASUREMENT

Type of measurement	Unit of measurement	Description
Volumetric flow rate	Sm ³ /h	Standard cubic metres per hour
	Scfh	Standard cubic feet per hour
Pressure	bar	Unit of measurement in the CGS system
	psi	Pounds per square inch
	"wc	water column inch
	Pa	Pascal
Temperature	°C	Degree centigrade
	°F	Fahrenheit degree
	K	Kelvin
Tightening torque	Nm	Newton metre
	ft-lbs	Foot per pound
Sound pressure	dB	Decibel
Other measurements	V	Volt
	W	Watt
	Ω	Ohm

Tab. 2.7.

2.10 - QUALIFIED PROFESSIONAL FIGURES

Qualified operators in charge of using and managing the equipment throughout its technical service life:

Professional figure	Definition
Mechanical maintenance technician	<p>Qualified technician able to:</p> <ul style="list-style-type: none"> perform preventive/corrective maintenance operations on all mechanical parts of the equipment subject to maintenance or repair; access all device parts for visual inspection, equipment checks, adjustments and settings. <p>The maintenance mechanical technician is not authorised to operate on live electrical systems (if any).</p>
Mechanical electric	<p>Qualified technician able to:</p> <ul style="list-style-type: none"> perform preventive/corrective maintenance operations on all electrical parts of the device subject to maintenance or repair; read wiring diagrams and check the correct functional cycle; perform adjustments and operate on electrical systems for maintenance, repair and replacement of worn parts. <p>The electrical maintenance technician can operate in the presence of voltage inside electrical panels, junction boxes, control equipment etc. only if he/she is deemed to be suitable (S.P.).</p> <p>For general requirements, refer to the IEC EN 50110-1:2014 standard.</p>
Worker in charge of transport, handling, unloading and placement on site	<p>Operator qualified to:</p> <ul style="list-style-type: none"> the use of lifting equipment handle materials and equipment. <p>The equipment must be lifted and handled strictly in accordance with the instructions provided by the manufacturer as well as the regulations in force at the place where the equipment is installed.</p>
Installer	<p>Qualified operator able to:</p> <ul style="list-style-type: none"> carry out all the operations necessary to properly install the equipment safely; perform all the operations necessary to properly operate the equipment and system safely.
User's technician	<p>Technician trained and authorized to use and manage the equipment for the activities for which it was supplied. They must:</p> <ul style="list-style-type: none"> be able to perform all operations required for the proper functioning of the equipment and the system, and for their safety and that of any personnel present; have proven experience in properly using the equipment similar to that described in this manual, and be trained, informed and instructed in this regard. <p>The technician may carry out maintenance only if authorised/qualified to do so.</p>

Tab. 2.8.

PAGE INTENTIONALLY LEFT BLANK

3 - SAFETY

3.1 - GENERAL SAFETY WARNINGS

WARNING!

The equipment described in this manual is:

- a device subjected to pressure in pressurised systems;
- normally installed in systems carrying flammable gases (for example: natural gas).

WARNING!

If the gas used is a combustible gas, the installation area of the equipment is defined as a 'danger zone' as there are residual risks that potentially explosive atmospheres may be generated.

In "danger zones" and in the immediate vicinity, the following are required:

- there must not be any effective sources of ignition;
- no smoking.

ATTENTION!

Authorised operators must not carry out operations or services on their own initiative that do not fall within their competence.

Never operate the equipment:

- while under the influence of intoxicating substances such as alcohol;
- if you are using drugs that may lengthen reaction times.

NOTICE!

The employer must train and inform operators on how to behave during operations and on the equipment to be used.

Before installation, commissioning or maintenance, operators must:

- take note of the safety regulations applicable to the place of installation they are working in;
- obtain the necessary permits to operate when required;
- wear the personal protective equipment required by the procedures described in this instruction manual;
- ensure that the required collective protective equipment and safety information are available in the area they are operating in;

3.2 - PERSONAL PROTECTIVE EQUIPMENT

Tab. 3.9 shows the personal protective equipment (PPE) and its description. An obligation is associated with each symbol. Personal protective equipment means any equipment intended to be worn by the worker in order to protect them against one or several risks that are likely to threaten their safety or health during work.

For the operators in charge, depending on the type of work requested, the most appropriate PPE of the following will be reported and must be used:

Symbol	Meaning
	Obligation to use safety or insulated gloves. Indicates a requirement for the personnel to use safety or insulated gloves.
	Obligation to use safety goggles. Indicates a requirement for personnel to use protective goggles for eye protection.
	Obligation to use safety shoes. Indicates a requirement for personnel to use accident-prevention safety shoes.
	Obligation to use noise protection equipment. Indicates a requirement for the personnel to use ear muffs or ear plugs to protect their hearing.
	Obligation to wear protective clothing. Indicates a requirement for personnel to wear specific protective clothing.
	Obligation to use a protective mask. Indicates a requirement for the personnel to use respiratory masks in the event of a chemical risk.
	Obligation to use a protective helmet. Indicates a requirement for the personnel to use protective helmets.
	Obligation to wear high visibility vests. Indicates a requirement for the personnel to use high visibility vests.

Tab. 3.9.

WARNING!

Each licensed operator is obliged to:

- **take care of his/her own health and safety and that of other people in the workplace who are affected by his/her actions or omissions, in accordance with the training, instructions and equipment provided by the employer;**
- **appropriately use the PPE made available;**
- **immediately report to the employer, the manager or the person in charge any deficiencies in the equipment and devices, as well as any dangerous conditions they may become aware of.**

3.3 - RESIDUAL RISKS

In accordance with the requirements of directive PED 2014/68/EU, point 1.2 of Annex I, below is an assessment of the risks associated with the equipment and an indication of the principles adopted for their prevention, according to the following classification:

- a) Elimination and/or reduction of the risk.
- b) Application of appropriate protective measures.
- c) Information to users about residual risks.

3.3.1 - TABLE SHOWING RESIDUAL RISKS DUE TO PRESSURE

Risk and Hazard	Event and Cause	Effect and Consequence	Solution and Prevention
Pressurised gas leakage. leakage Projection of metallic and non-metallic pressurised parts.	<ul style="list-style-type: none"> Violent impact; Impact (also due to falling, improper handling, etc.). 	<ul style="list-style-type: none"> Deformation; Broken connections and, if pressurised, even burst. 	a. Handling and installation with appropriate devices to avoid localised stress. b. Installation in suitable places and spaces with appropriate guards and packaging. c. Information in the instructions for use and warning.
Pressurised gas leakage. leakage Projection of metallic and non-metallic pressurised parts. metallic and not in leakage	<ul style="list-style-type: none"> Use of inappropriate fluids. 	<ul style="list-style-type: none"> Corrosion; Embrittlement; Explosion. 	a. The user must check compliance of the used fluid with the specifications on the data plate.
Pressurised gas leakage. leakage Projection of metallic and non-metallic pressurised parts. metallic and not in leakage	<ul style="list-style-type: none"> Operation at temperatures below the minimum permissible temperature. 	<ul style="list-style-type: none"> Embrittlement; Breakage; Explosion. 	a. Install in places where the temperature is not below the minimum permissible temperature and/or insulate the equipment adequately. b. The minimum temperature allowed is indicated on the data plate.
Pressurised gas leakage. leakage Projection of metallic and non-metallic pressurised parts. Explosion.	<ul style="list-style-type: none"> Overpressure or exceedance of the rated limit values (maximum pressure allowed) 	<ul style="list-style-type: none"> Explosion; Breaks; Cracks; Permanent deformations. 	a. The device has appropriate design safety margins. b. The user must check the maximum pressure applicable to the equipment. c. The maximum allowable pressure is highlighted on the appropriate plate on the equipment.
Falling of the equipment.	<ul style="list-style-type: none"> Dangerous handling. 	<ul style="list-style-type: none"> Deformation; Cracking; Breakage. 	b. The user must have suitably sized lifting equipment. c. The above requirements are referred to in the equipment use and warning manual.
Pressurised fluid leakage Projection of metallic and non-metallic pressurised parts. metallic and not in leakage	<ul style="list-style-type: none"> Incorrect fastening of the equipment. 	<ul style="list-style-type: none"> Deformation; Breakage. 	a. The device is equipped with unified type process connections and press fittings. b. The user must ensure correct fixing to the line. c. Directions in the instructions for use and warning.

Risk and Hazard	Event and Cause	Effect and Consequence	Solution and Prevention
Explosion of the device. Pressurised fluid leakage Projection of metallic and non-metallic pressurised parts. metallic.	<ul style="list-style-type: none"> Operation at temperatures above the maximum permissible temperature. 	<ul style="list-style-type: none"> Reduction of mechanical resistance and breakage of the device; Explosion. 	a. The user must equip the system with suitable control and safety devices. b. The maximum temperature allowed is indicated on the data plate.
Pressurised gas leakage	<ul style="list-style-type: none"> Equipment maintenance with the system running. 	<ul style="list-style-type: none"> Inappropriate opening of pressurised chambers. 	a. The user must perform any maintenance with the equipment not running. b. The above requirements are referred to in the use and warning instructions.
Pressurised gas leakage Projection of metallic and non-metallic pressurised parts. metallic and not in leakage	<ul style="list-style-type: none"> External loads bearing on the device. 	<ul style="list-style-type: none"> Deformation; Cracking and fissure formation; If under pressure, also bursting. 	a. With the exclusion of what is set out in the design, the user must verify that no additional concentrated load bears on the device.
Pressurised gas leakage Projection of metallic and non-metallic pressurised parts. metallic and not in leakage	<ul style="list-style-type: none"> Electrostatic potential, differential stray currents. 	<ul style="list-style-type: none"> Localised corrosion in the device. 	b. The user must equip the device with the necessary protection and earthing devices. c. The above requirements are referred to in the use and warning manual.
Pressurised gas leakage Projection of metallic and non-metallic pressurised parts. metallic and not in leakage	<ul style="list-style-type: none"> Humidity; Environments with aggressive atmosphere. 	<ul style="list-style-type: none"> Deterioration of external surfaces; Corrosion. 	a. The user must periodically check the state of conservation of the external surfaces. b. The above requirements are referred to in the use and warning instructions.

Tab. 3.10.

3.3.2 - TABLE OF RESIDUAL RISKS FOR POTENTIALLY EXPLOSIVE ATMOSPHERES

Tab. 3.11 shows the conditions that can lead to the generation of a potentially explosive atmosphere respectively for:

- ASX 176 pressure regulator;
- of the PM/176 monitor;
- of the SSX/176 slam-shut valve.

Considering that the silencer does not have active functional parts, in this analysis it is considered an integral part of the ASX 176 regulator.

The table is valid for use with natural gas with a density of no more than 0.8; for different densities, the installation and environmental conditions must also be evaluated.

WARNING!

If the gas used is a combustible gas, the installation area of the equipment is defined as a 'danger zone' as there are residual risks that potentially explosive atmospheres may be generated. There must be no effective sources of ignition in 'danger zones' and in close proximity thereto.

Operational operational	Atmosphere potentially explosive	Normative references	Management measures included in the instructions for use and warning
First start-up	No	<ul style="list-style-type: none"> • During the production cycle and before the CE marking according to Directive 2014/68/EU, the external tightness of the equipment is checked at a value of 1.1 PS (in accordance with Standard EN 334). • Before commissioning, the external sealing of the system portion on which the equipment is installed is checked at a suitable pressure (in accordance with the provisions of standards EN 12186 and EN 12279). 	The instructions for use indicate the need to meet the requirements in Standards EN 12186 and EN 12279.
Operation in normal conditions	No	<p>The indications in the previous point apply, in addition:</p> <ul style="list-style-type: none"> • the equipment is installed outdoors or in an environment with natural ventilation (in accordance with Standards EN 12186 and EN 12279); • the installation is subject to surveillance according to current national rules/good practice/the equipment manufacturer's instructions (in accordance with the provisions of Standard EN 12186 and Standard EN 12279). 	<p>The instructions for use indicate that:</p> <ul style="list-style-type: none"> • any environment in which the equipment is installed must meet the requirement of Standards EN 12186 and EN 12279; • periodic checks and maintenance must be carried out during surveillance in accordance with the national rules in force (if any), and with the specific manufacturer's recommendations.

Operational operational	Atmosphere potentially explosive	Normative references	Management measures included in the instructions for use and warning
Breakage of the control head diaphragm (malfunction)	No	<p>This event must be considered a rare malfunction.</p> <p>All atmospheric pressure chambers delimited on at least one side by a diaphragm must be channelled to a safe area (in accordance with the provisions of Standard EN 12186 and Standard EN 12279).</p>	The instructions for use indicate the need to meet the requirements of Standards EN 12186 and EN 12279.
Breakage of other parts non-metallic (malfunction)	No	This type of malfunction is not reasonably expected as it involves static sealing (to the outside).	-
Decommissioning	No	<ul style="list-style-type: none"> The pressure of the system section in which the equipment is installed must be reduced with appropriate vent lines channelled to a safe area (in accordance with the provisions of Standard EN 12186 and Standard EN 12279). The residual gas must be discharged as indicated above. 	The instructions for use indicate the need to meet the requirements of Standards EN 12186 and EN 12279
Reboot	No	<ul style="list-style-type: none"> After reassembling the equipment, carry out an external leakage test at a suitable pressure value, as specified by the manufacturer. Before commissioning, the external sealing of the system portion on which the equipment is installed is checked at a suitable pressure (in accordance with the provisions of standards EN 12186 and EN 12279). 	<p>The instructions for use indicate:</p> <ul style="list-style-type: none"> the minimum conditions for testing external leakage; the need to meet the requirements of Standards EN 12186 and EN 12279.

Tab. 3.11.

3.4 - OBLIGATIONS AND PROHIBITIONS

The following is a list of obligations and prohibitions to be observed for the safety of the operator.

Is mandatory:



- to carefully read and understand the instructions for use and warning;
- verify that downstream equipment is adequately sized according to the performance required of the equipment under actual operating conditions
- before installing the equipment, to strictly refer to the details specified on the nameplates;
- to avoid violent shocks and impacts that could damage the equipment and, as a result, cause the pressurised fluid to leak.

It is forbidden to:

- operate in various capacities on the equipment without the PPE indicated in the work procedures described in these use and warning instructions;
- operate in the presence of open flames or bring open flames close to the work area;
- smoke near the equipment or while working on it;
- use the equipment with parameters other than those indicated on the name plate;
- use the equipment with fluids other than those indicated on the rating plate and in these use and warning instructions;
- use the equipment outside the operating temperature range specified on the rating plate and in these use and warning instructions;
- service the equipment with the system portion, on which it is installed, in operation;
- install or use the equipment in environments other than those specified in these instructions for use and warning.

3.5 - SAFETY PICTOGRAMS

The following safety pictograms may be shown on the equipment and/or packaging PIETRO FIORENTINI S.p.A.:

Symbol	Definition
	Symbol used to identify an ELECTRICAL HAZARD.
	Symbol used to identify a GENERIC HAZARD.

Tab. 3.12.

HAZARD!

It is absolutely forbidden to remove the safety pictograms on the equipment.

The user is required to replace the safety pictograms which, following wear, removal or tampering, are illegible.

3.6 - NOISE LEVEL

Depending on the operating conditions, for the required use and configuration, the equipment may generate noise beyond the limits allowed by current legislation in the country of installation.

For the value of the noise generated by the equipment and further information, contact PIETRO FIORENTINI S.p.A..

ATTENTION!

The obligation to use earmuffs or ear plugs to protect the operator's hearing remains in the event that the noise in the installation environment of the equipment (depending on specific operating conditions) exceeds the value of 85 dBA.

PAGE INTENTIONALLY LEFT BLANK

4 - DESCRIPTION AND OPERATION

4.1 - GENERAL DESCRIPTION

The equipment ASX 176 is a piloted pressure regulator for medium and high pressure which reduces the inlet gas pressure, keeping the downstream value stable even when the following varies:

- inlet pressure value;
- the required flow rate within the operating conditions of the equipment.

The regulator ASX 176 consists of (see Fig. 4.1):

Pos.	Description	Pos.	Description
1	Main regulator	5	Regulator plug
2	Piloting unit	6	Reinforced gasket
3	Pre-regulator R14/A	7	Main diaphragm
4	200/A series pilot		

Tab. 4.13.

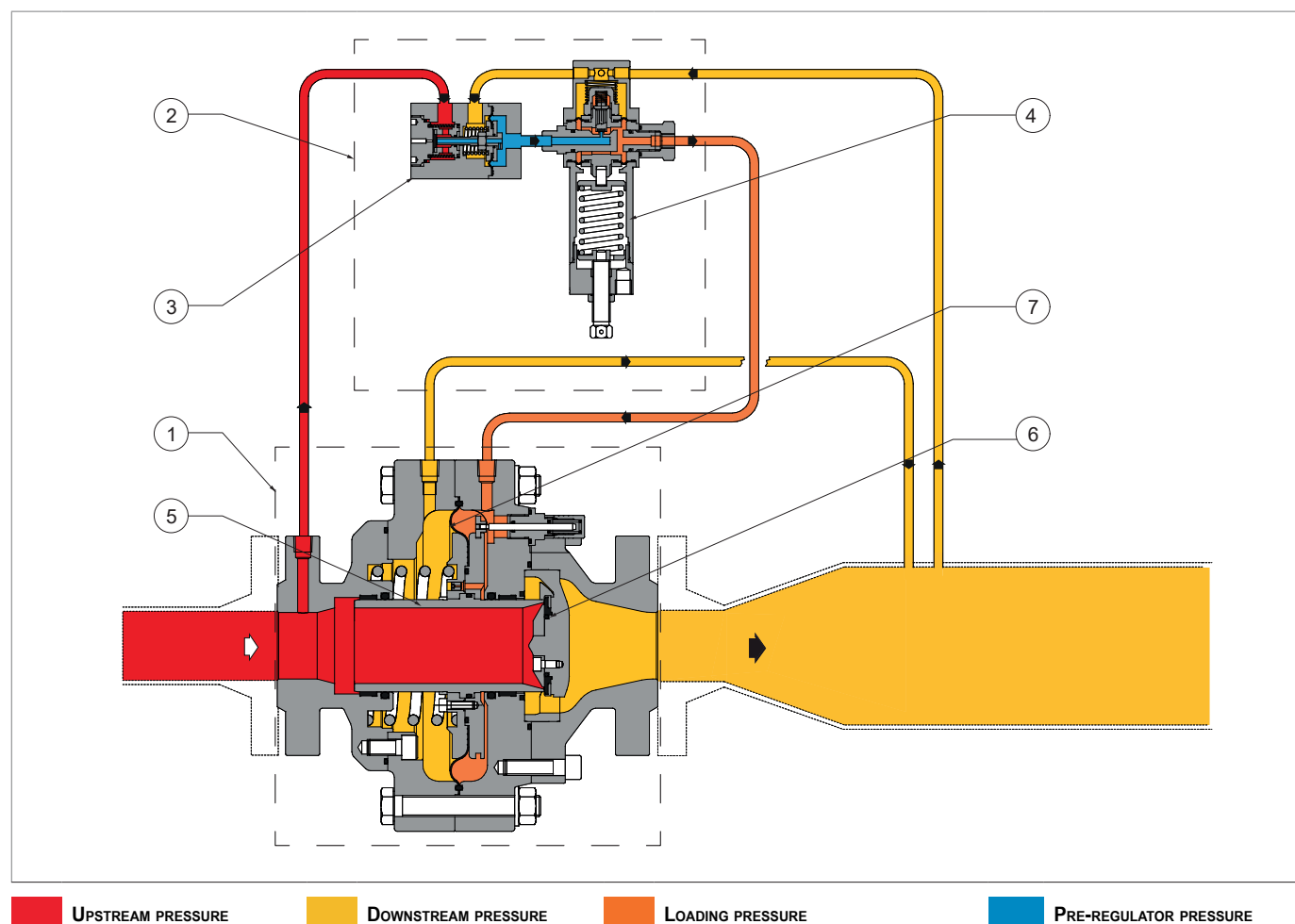

Fig. 4.1. General description ASX 176

4.1.1 - REGULATOR REACTION MODES

The ASX 176 equipment is a regulator controlled with a "fail close" reaction (on-closure reaction), that is, it closes in the event of:

- breakage of main diaphragm;
- breakage of the pilot diaphragm;
- no power supply in the pilot.

Equipment ASX 176 allows installation of the 210/A series pilot. This series of pilots changes the way the regulator reacts in the event of a rupture of the pilot membrane.

4.2 - OPERATION

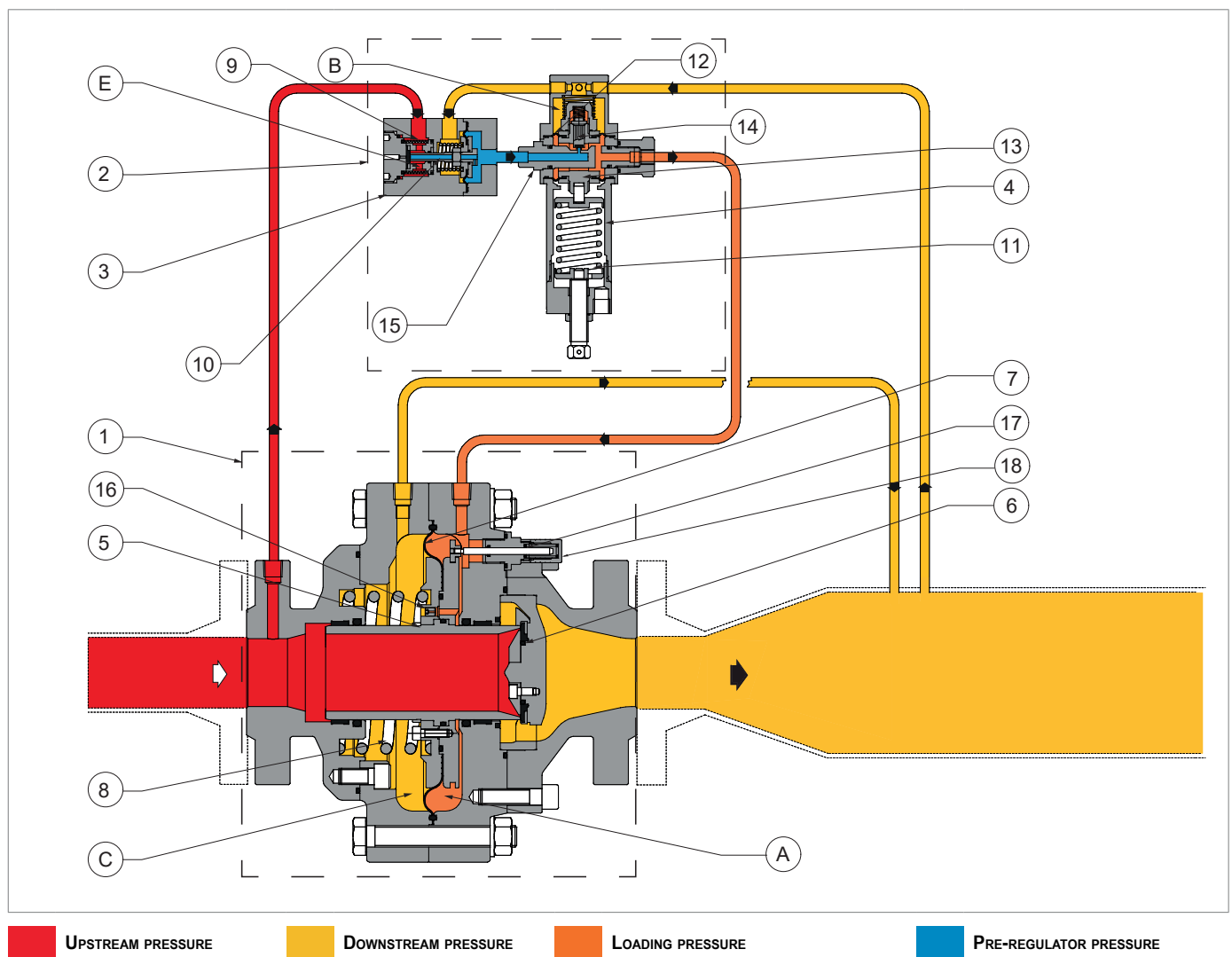

Fig. 4.2. Operation ASX 176

NOTICE!

To check the position of the plug (5), look at the position of the stroke indicator rod (17) referring to the slide (18):

- fully open 100%;
- closed 0%.

In depressurised conditions, the regulator plug (5) is kept in a shut-off position by the spring (8) and rests on the reinforced gasket (6). The upstream pressure, although variable, does not change this position since the regulator plug (5) is fully balanced.

The position of the regulator plug (5) is controlled by the main diaphragm (7) on which the following forces act:

- during shut-off: load of the spring (8) and thrust resulting from the downstream pressure (P_d) in the chamber (C);
- when opening: thrust generated by the loading pressure (P_m) supplied by the pilot (4) in the chamber (A).

When the regulator is installed in a vertical position, the weight of the mobile unit acts on the above mentioned forces during both opening and shut-off.

The loading pressure (P_m) is obtained from the upstream piping of the regulator (1). The gas enters the pre-regulator (3), passes through the filter (9) and its pressure is reduced to a fixed value of the pressure in the pre-regulator (P_{ep}), which depends on the regulator calibration pressure.

Pressure at the pre-regulator (P_{ep}) enters the pilot (4) from the pre-regulator (3). The pilot (4) regulates the value of the loading pressure (P_m) to be supplied into the chamber (A) of the regulator in order to open the plug (5) of the regulator through the opening of the plug (14).

The loading pressure (P_m) is set by comparing:

- the force exerted by the pilot calibration spring (11);
- the action of the downstream pressure (P_d), which acts on the diaphragm (12) in the chamber (B).

The loading circuit is an open circuit with continuous discharge by means of a transfer hole (16) in the diaphragm protection disc with discharge to the downstream pressure in the chamber (C).

Under normal operating conditions, the plug (14) of the pilot is positioned so that the value of the motorised pressure (P_m) is such that the value of the downstream pressure (P_d) remains around the calibration value.

Operating conditions	Operating consequences	Outcome
Drop in downstream pressure (P_d) for: <ul style="list-style-type: none"> • rise in the requested flow rate; • drop in upstream pressure (P_u). 	Imbalance in the mobile unit (13) of the pilot (4), which causes the plug (14) of the pilot (4) to open.	<ul style="list-style-type: none"> • Increase in loading pressure (P_m); • Move the regulator plug (5) during opening until the downstream pressure calibration value (P_d) is restored.
Increased downstream pressure (P_d) due to: <ul style="list-style-type: none"> • drop in the requested flow rate; • increase in upstream pressure (P_u). 	The force exerted by the downstream pressure (P_d) on the pilot diaphragm moves the mobile unit (13) and shifts the plug (14) of the pilot (4) to the shut-off position.	<ul style="list-style-type: none"> • Decrease in loading pressure (P_m); • Move the regulator plug (5) during shut-off until the downstream pressure calibration value (P_d) is restored.

Tab. 4.14.

4.3 - DESIGNED USE

4.3.1 - INTENDED USE

The equipment in question is intended for:

Operation	Permitted	Not permitted	Work environment
Adjustment of the downstream pressure for:	Gaseous, and non-corrosive, fluids that have been filtered beforehand.	<ul style="list-style-type: none"> Liquids. Any product other than those permitted. 	Installations to carry and convey natural gas to networks for: <ul style="list-style-type: none"> civil use; industrial use.

Tab. 4.15.

The equipment in question is used as a main controller and in-line monitor controller.

It was designed to be used exclusively within the limits specified on the rating plate and according to the instructions and limits of use referred to in this manual.

Safe work conditions are as follows:

- use within the limits stated on the rating plate and in this manual;
- compliance with the user manual procedures;
- routine maintenance to be carried out when and how recommended;
- special maintenance to be carried out if required;
- do not tamper with and/or bypass the safety devices.

4.3.2 - REASONABLY FORESEEABLE MISUSE

Incorrect and reasonably foreseeable use means the use of the equipment in a way not foreseen in the phase but which can result from readily foreseeable human behaviour:

- corrosive fluids;
- fluids not properly treated upstream;
- liquids;
- instinctive reaction of an operator in the event of a malfunction, accident or breakdown while using the equipment;
- behaviour resulting from pressure to keep the equipment running under all circumstances;
- behaviour resulting from carelessness;
- behaviour resulting from the use of the equipment by unauthorised and unsuitable people;
- using the equipment in a manner other than that referred to under paragraph "Intended use";

Any use of the equipment other than the intended use must be previously approved in writing by PIETRO FIORENTINI S.p.A. If no written approval is provided, use shall be considered "improper".

In the event of improper use, PIETRO FIORENTINI S.p.A. shall not be held liable for any damage caused to people or property, and any type of warranty on the equipment shall be deemed void.

4.3.3 - TYPES OF FLUIDS

The equipment works with combustible gases used:

- in pressure control stations according to EN 12186 or EN 12279;
- in transmission and distribution networks.
- in commercial and industrial plants (after checking by contacting the Manufacturer).

NOTICE!

The equipment may be also used with inert gases, subject to verification by contacting the manufacturer.

4.4 - TECHNICAL FEATURES/PERFORMANCE

The ASX 176 equipment is a medium and high pressure axial type of regulator. The regulation system is balanced and guarantees a stable outlet pressure even when the inlet pressure varies.

The main specifications for this regulator are:

Technical features	
Maximum allowable pressure	Up to 102 bar
Ambient temperature range	-10 °C - +60 °C (class 1) -20 °C - +60 °C (class 2)
Inlet gas temperature range	-20 °C + 60 °C
Inlet pressure range (bpu)	0.8 - 100 bar
Possible regulation range (Wd)	0.3 - 74 bar (depending on the pilot installed)
Minimum differential pressure	0.5 bar
Accuracy class (AC)	up to 1 (depending on operating conditions)
Lock up pressure class (SG)	up to 2.5 (depending on operating conditions)

Tab. 4.16.

Cg, Kg and K1 coefficients					
Nominal diameter [mm]	25	50	80	100	150
Size [inches]	1"	2"	3"	4"	6"
Coefficient Cg	630	2300	5000	8800	19000
Kg coefficient	663	2420	5260	9258	19988
Coefficient K1	145	145	145	145	145

Tab. 4.17.

4.5 - POSSIBLE CONFIGURATIONS

The ASX 176 equipment can have different configurations through the installation of the following accessories:

- Built-in silencer LDB/176;
- PM 176 built-in monitor;
- Built-in slam-shut valve SSX/176.

The possible configurations are described in Tab. 4.18:

ASX 176	Silencer LDB/176	Monitor PM/176	Slam-shut valve SSX/176
LDB/176 silencer	-	Yes	Yes
PM/176 monitor	Yes	-	No
SSX/176 slam-shut valve	Yes	No	-

Tab. 4.18.

The accessories can be installed directly at the factory or, at a later time, directly on site.

 **NOTICE!**

The installation of accessories is described in the relevant chapter of this manual.

4.5.1 - BUILT-IN SILENCER

The LDB/176 silencer (1) is incorporated in the regulator (2).

The LDB/176 silencer (1) reduces the noise generated by the equipment during the lamination process. Noise is absorbed precisely where it is generated, which prevents it from propagating.

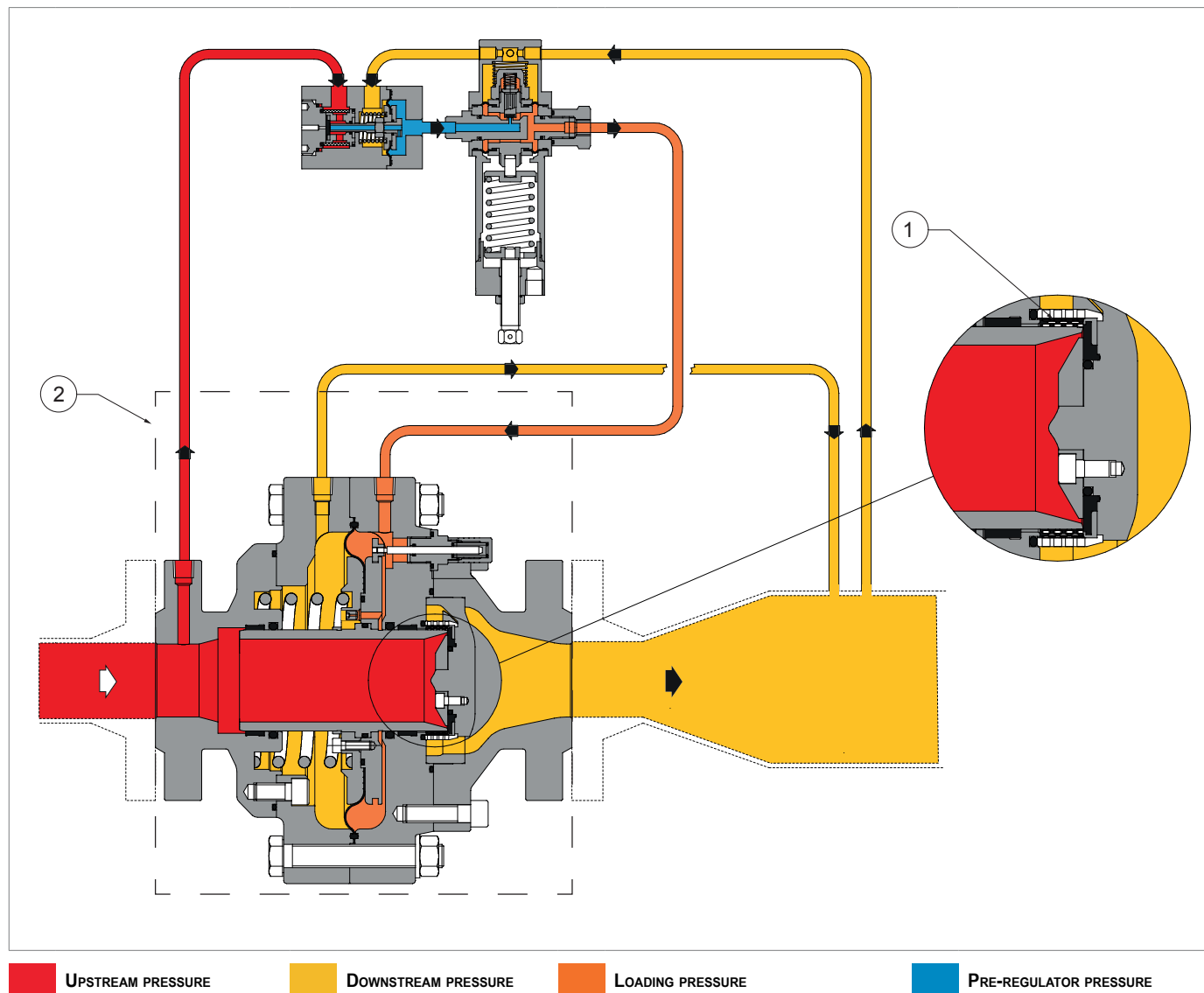

Fig. 4.3. Built-in silencer LDB/176

4.5.2 - MONITOR

The PM/176 monitor (1) is installed upstream of the main pressure regulator (2) in a fully open position during normal operation.

The PM/176 (1) monitor is used to keep the pressure value downstream of the main regulator within the pre-set limits in case of failure.

The PM/176 (1) monitor can be:

- incorporated in the regulator (2);
- installed in line with the regulator (2).

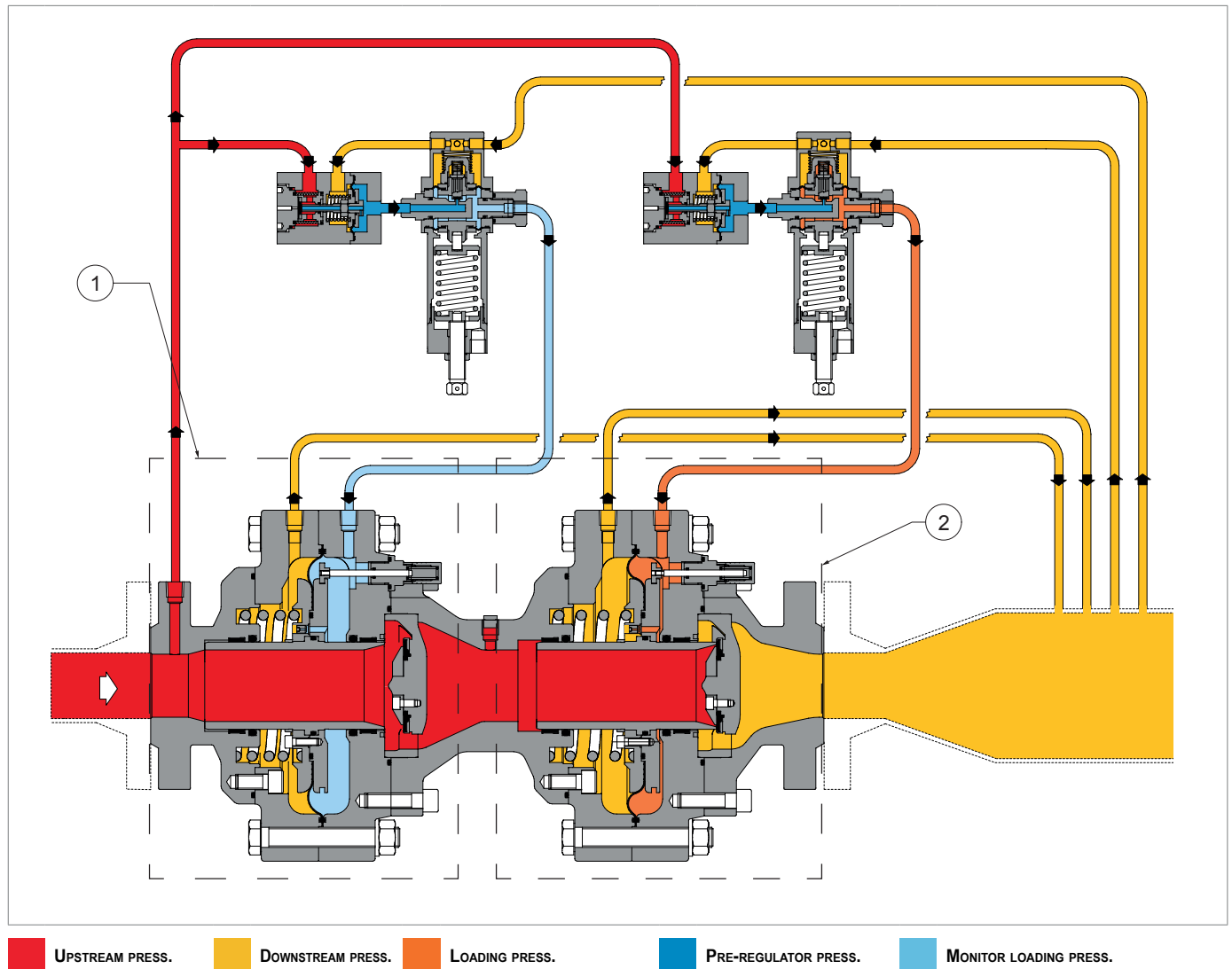

Fig. 4.4. ASX 176 with built-in monitor PM/176

4.5.2.1 - BUILT-IN MONITOR

The PM/176 monitor (1) is mounted in series directly on the service regulator housing (2). The PM/176 (1) monitor is normally in stand-by position, fully open, and in the event of a fault in the main regulator, it comes into operation, ensuring correct pressure regulation.

Monitor PM/176 (1) and the main regulator are controlled by:

- two separate pilots;
- independent servomotors.

BUILT-IN MONITOR OPERATION

! NOTICE!

To check the position of the plug (3), look at the position of the stroke indicator rod (8) referring to the glass cover (9):

- fully open 100%;
- closed 0%.

In depressurised conditions, the plug (3) is kept in a closed position by the spring (4) and rests on the reinforced gasket (5). The upstream pressure (P_u), although variable, does not change this position as the plug (3) is fully balanced.

The position of the plug (3) is controlled by the movements of the diaphragm (6) that the forces act on:

- during shut-off: the load of the spring (4) and thrust resulting from the downstream pressure (P_d) in the chamber (C),
- in opening: towards the open position: the thrust resulting from the loading pressure (P_m) in the chamber (D), supplied by the pilot (7).

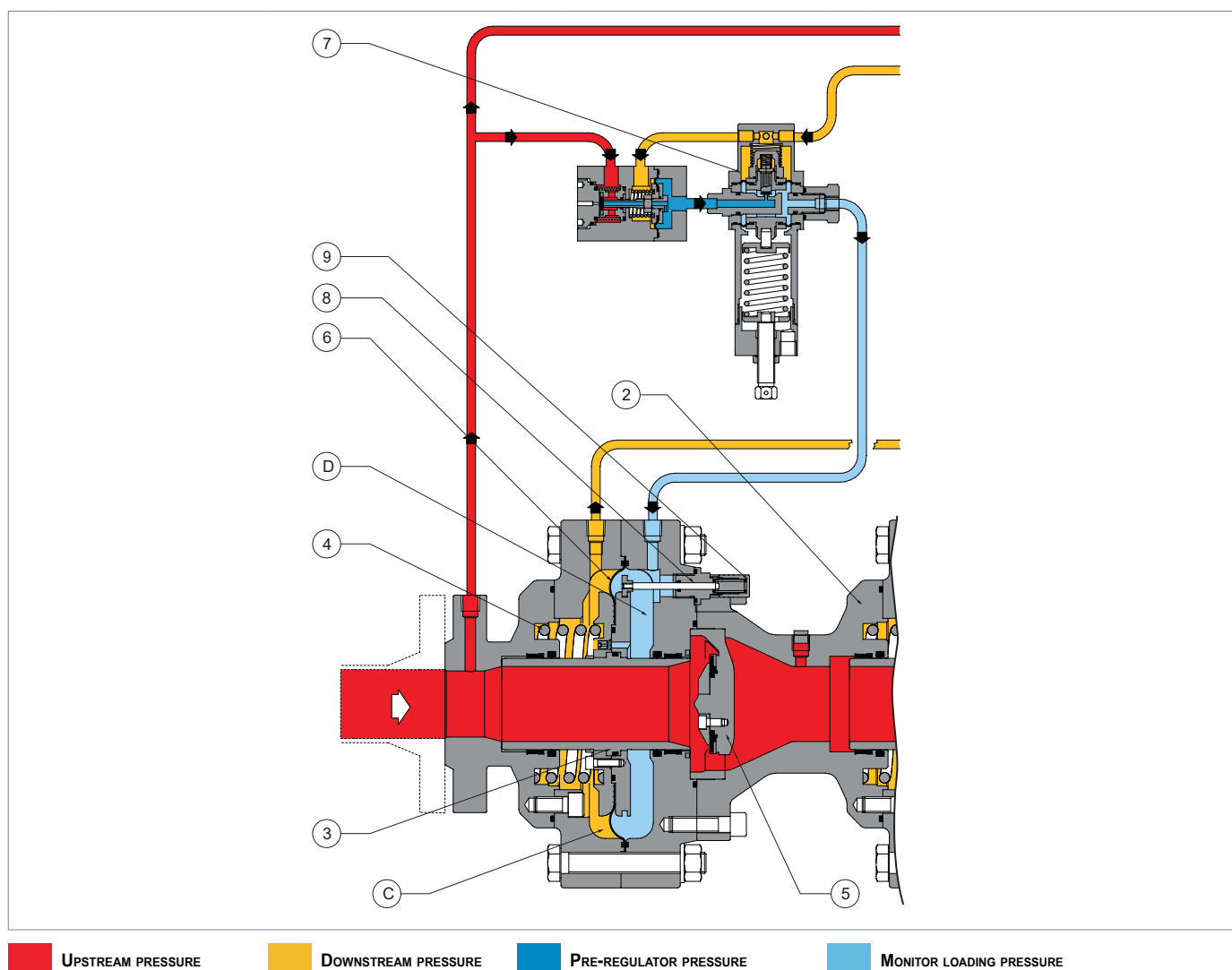
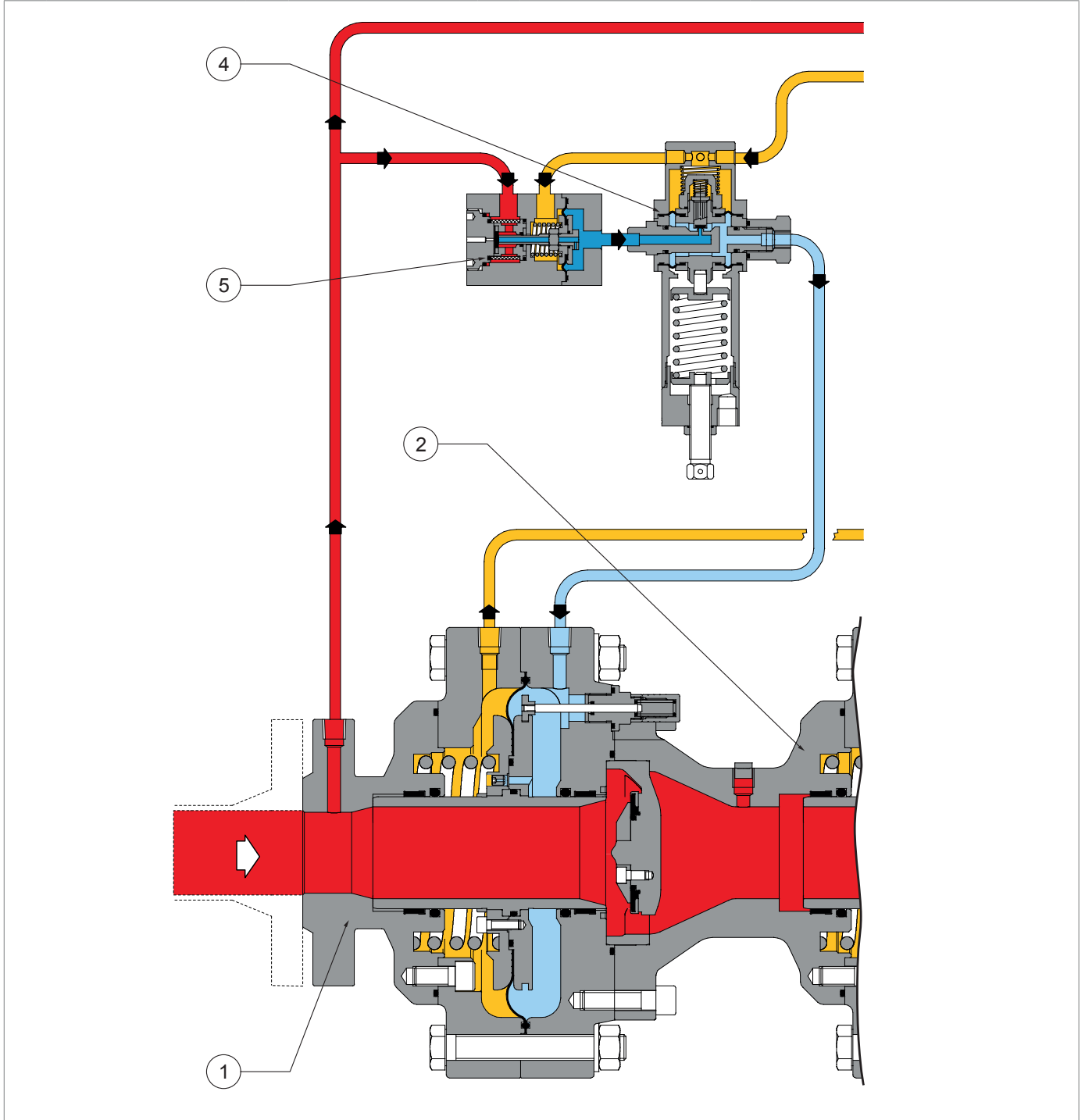

Fig. 4.5. Incorporated monitor operation

OPERATION OF THE BUILT-IN MONITOR IN STAND-BY CONDITIONS:

The built-in PM/176 monitor (1), during regular operation, is normally open given the pilot calibration (4) which is higher than the main regulator pilot calibration (2).

The passage of the pre-regulator pressure (Pep), generated by the R14/A pre-regulator (5) through the completely open pilot (4), also keeps the PM/176 built-in monitor (1) fully open.



■ UPSTREAM PRESSURE
 ■ DOWNSTREAM PRESSURE
 ■ PRE-REGULATOR PRESSURE
 ■ MONITOR LOADING PRESSURE

Fig. 4.6. Operation of the built-in monitor in stand-by conditions

PAGE INTENTIONALLY LEFT BLANK

BUILT-IN MONITOR OPERATION IN THE EVENT OF FAILURE OF THE MAIN REGULATOR:

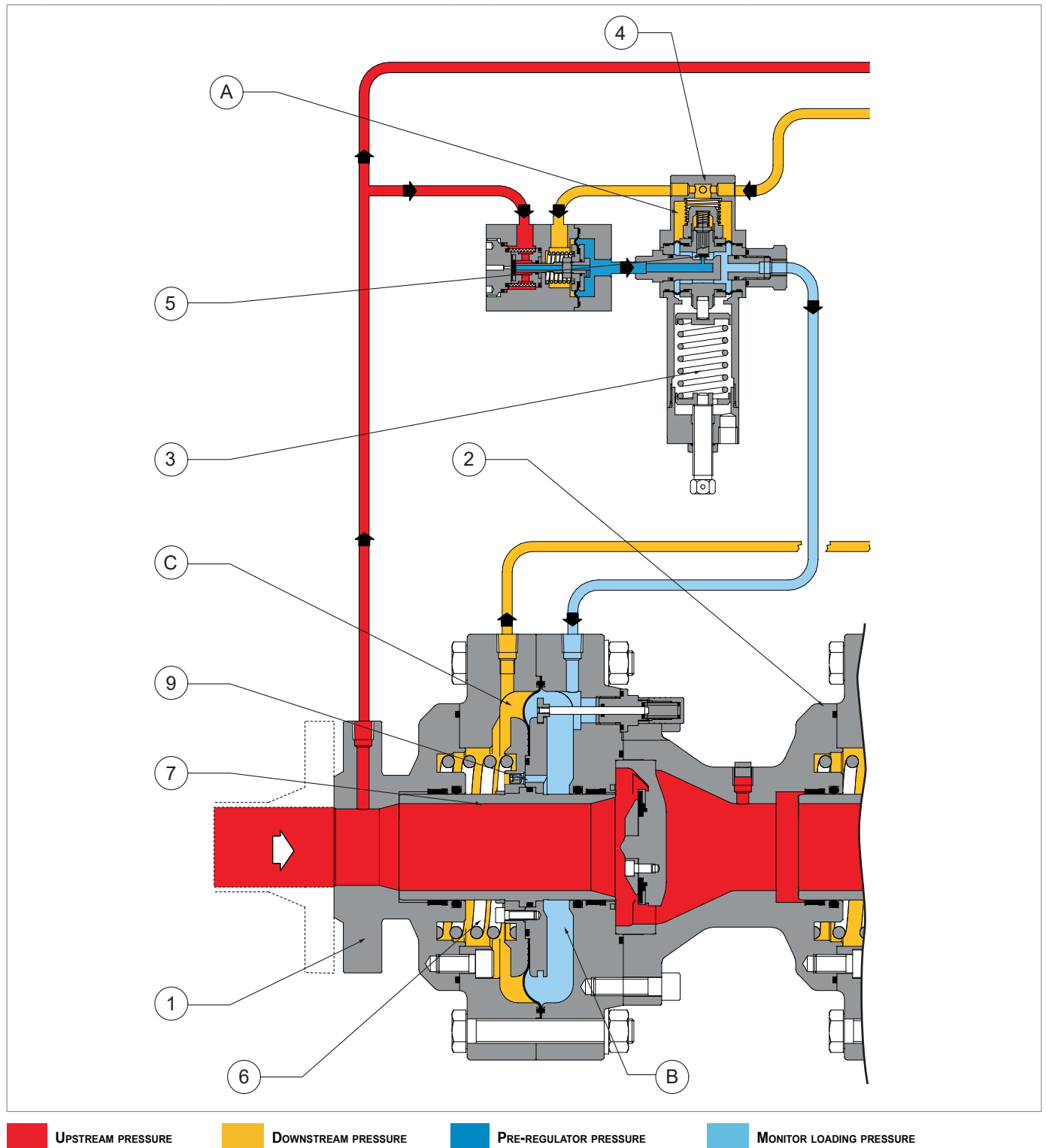

Fig. 4.7. Built-in monitor operation in the event of failure of the main regulator

In the event of failure of the main regulator (2), the PM/176 monitor (1) will be tripped until the pre-set downstream pressure has been reached.

Operating conditions	Operating consequences	Outcome
Decrease in downstream pressure (Pd) due to: <ul style="list-style-type: none"> • rise in the requested flow rate; • or decrease in upstream pressure (Up). 	Imbalance between the pressure force in the chamber (A) and the calibration spring (3) of the pilot (4) which causes: <ul style="list-style-type: none"> • increased opening of the pilot (4) plug (5); • consequent increase in the value of the loading pressure (Pm), inside the chamber (B). 	Opening of the plug (7) of the PM/176 monitor (1) until the equilibrium of forces between the downstream pressure (Pd) in the chamber (A) and the calibration spring (3) of the pilot (4) has been restored.
Increase in downstream pressure (Pd) with the pilot (4) plug (5) being moved to the shut-off position.	Move the plug (7) of the PM/176 monitor (1) to the shut-off position for: <ul style="list-style-type: none"> • the decrease in the loading pressure (Pm) due to the transfer of this pressure between the chambers (B) and (C) of the regulator (2) through the transfer hole (9); • force applied by the spring (6). 	Return of the downstream pressure (Pd) to the predetermined value and to the balance of forces between the downstream pressure (Pd) in the chamber (A) and the calibration spring (3) of the pilot (4).

Tab. 4.19.

4.5.2.2 - M/A ACCELERATING VALVE

NOTICE!

For the monitor to be used as a safety accessory according to “PED” Directive 2014/68/EU, installing the M/A accelerating valve is recommended.

In the event of a malfunction of the main regulator (2), the M/A accelerating valve (3) is installed to speed up tripping of the built-in PM/176 monitor (1).

The M/A accelerating valve (3), based on a downstream pressure signal (P_d), discharges the gas contained in the loading chamber of the monitor into the atmosphere, thus enabling more rapid tripping.

The calibration of the M/A accelerating valve:

- must be higher than the shut-off pressure of the monitor (1) with reference to the specific SG value;
- is carried out by turning the adjusting screw (4) clockwise or anti-clockwise to increase or decrease its value.

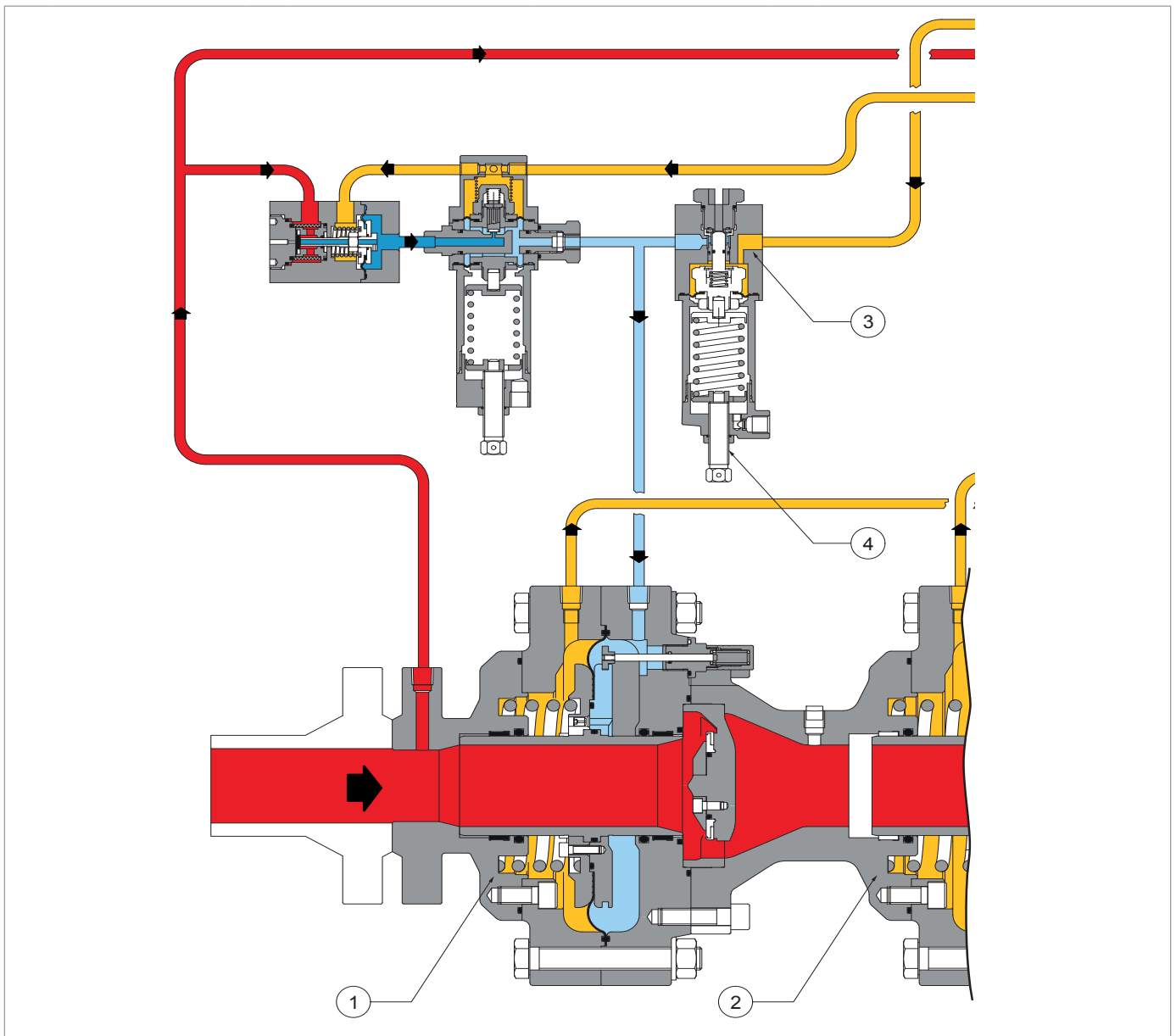

 UPSTREAM PRESSURE
  DOWNSTREAM PRESSURE
  PRE-REGULATOR PRESS.
  MONITOR LOADING PRESSURE

Fig. 4.8. M/A accelerating valve

4.5.3 - SLAM-SHUT VALVE

The slam-shut valve is a safety device is used to shut off the gas flow if the pressure value at the control point exceeds the calibration value of the valve itself.

The slam-shut valve is incorporated in the main regulator of the equipment and consists of:

- a control system;
- the slam-shut device mechanism.

In the event of triggering, the slam-shut valve shuts off power supply to the regulator and its control pilot.

4.5.3.1 - BUILT-IN SLAM-SHUT VALVE SSX/176

The built-in slam-shut valve SSX/176 can be operated:

- by the pressure switch;
- manually;
- with remote control.

The main features of the SSX/176 built-in slam-shut valve are:

- balanced valve plug;
- local shut-off button;
- tripping due to downstream pressure increase and/or decrease;
- built-in bypass;
- manual resetting only.

Pressure switch type	Set	Operating range (bar)	AG
Mod. 102M	max	0.2 - 5.5	5
	min	0.05 ÷ 0.2	30
	min	0.2 ÷ 2.8	10
Mod. 103M	max	2 - 7	5
	max	7 - 22	2.5
	min	0.2 ÷ 2	10
	min	2 - 8	2.5
Mod. 104M	max	15 - 45	2.5
	min	1.6 ÷ 8	5
	min	8 - 18	2.5
Mod. 105M	max	30 - 90	2.5
	min	3 - 16	5
	min	16 - 44	2.5
Mod. 102MH	max	0.2 - 5.5	5
	min	2.8 - 5.5	2.5
Mod. 103MH	max	2 - 7	5
	max	7 - 22	2.5
	min	8 - 19	5
Mod. 104MH	max	15 - 45	2.5
	min	18 - 41	2.5
Mod. 105MH	max	30 - 90	2.5
	min	44 - 90	2.5

Tab. 4.20.

The SSX/176 built-in slam-shut valve consists of:

Pos.	Description
1	Slam-shut valve plug
2	LINE OFF 2.0 device

Tab. 4.21.

The LINE OFF 2.0 device (2) consists of:

Pos.	Description
4	HP2/2: filtering device of the gas supplying the control circuit; it also acts as a bypass necessary for resetting the built-in slam-shut valve SSX/176.
5	R44/SS: pressure regulator necessary to decrease the upstream pressure of the equipment to the loading pressure of the SSX/176 built-in slam-shut valve cylinder.
6	AR100: flow throttle valve to adjust the pressure loading speed in the pneumatic circuit and to filter the gas entering the R44/SS regulator (6).
	 NOTICE! The load speed is adjusted by a screw (minimum value 1, maximum value 8).
7	VS/FI: safety valve used to: <ul style="list-style-type: none"> • discharge any overpressure generated by malfunction of the R44/SS pressure regulator into the atmosphere; • protect the entire circuit downstream of the R44/SS pressure regulator.
8	Valve 3/2: used to pressurise and depressurise the chamber (C) of the SSX/176 built-in slam-shut valve.
9	Control pressure switch: through the head of the control pressure switch connected downstream, it is used to trip the SSX/176 built-in slam-shut valve due to decreases or increases in downstream pressure.

Tab. 4.22.

 **NOTICE!**

To check the position of the plug (1), look at the position of the stroke indicator rod (17) referring to the glass cover (18):

- **fully open 100%;**
- **closed 0%.**

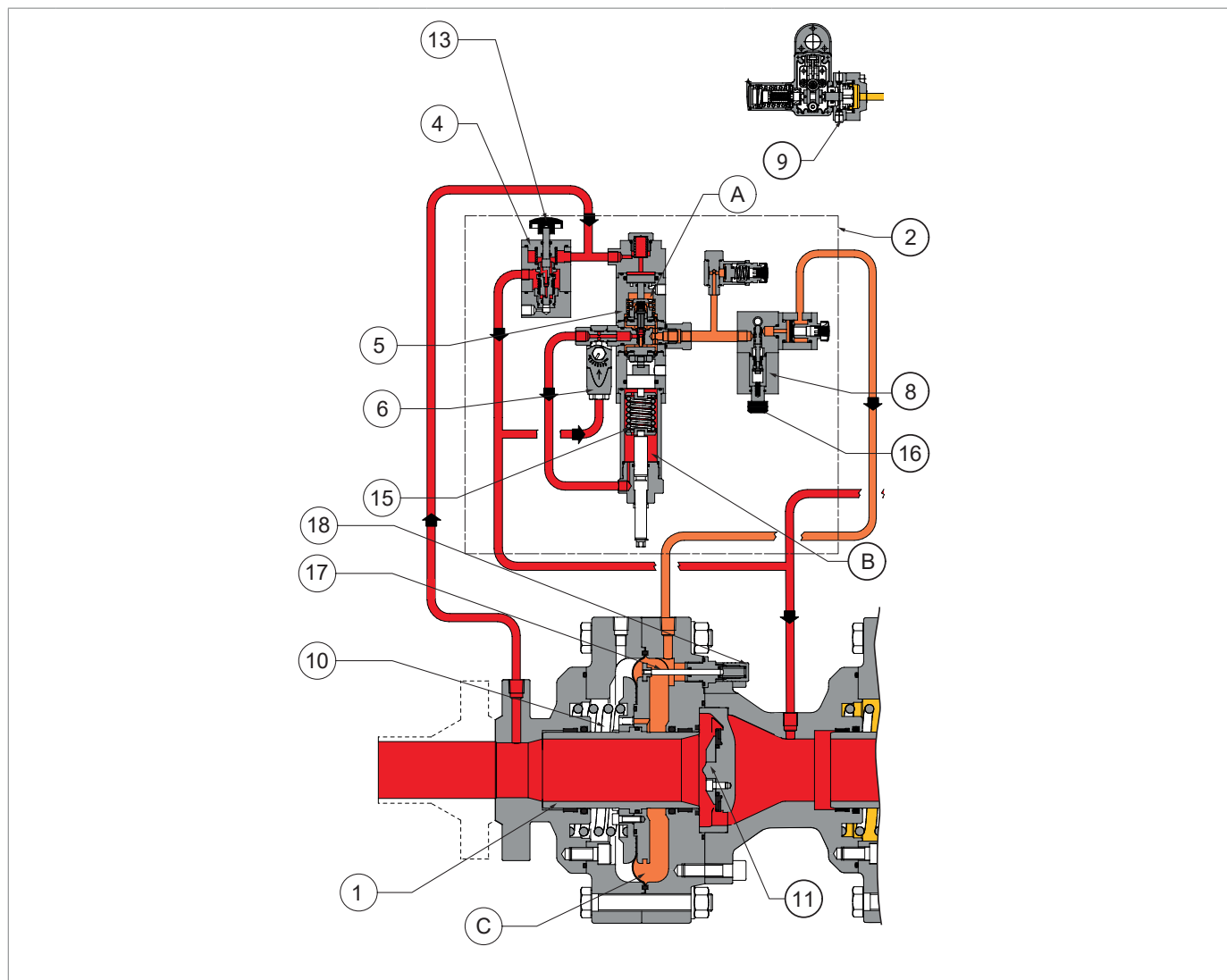

Fig. 4.9. ASX 176 with built-in slam-shut valve SSX/176

OPERATION:

At no pressure, the valve plug (1) is kept in the shut-off position by the spring (10) and rests on the reinforced gasket (11).

The upstream pressure (U_p) reaches the HP2/2 bypass device (4) and the upper head (A) of the R44/SS regulator (6) to prevent inappropriate resetting of the valve. By adjusting the activation button (13) of the bypass, the pressurised gas is filtered and feeds the AR100 throttle valve (5), which in turn supplies:

- the chamber of the adjustment spring (B);
- the R44/SS regulator (6), calibrated at a pressure of 4.5 bar to overcome the force of the shut-off spring (15) of the main valve.

Pressing the reset lever (16) acts on the pressure switch coupling system (9), so as to allow, through the 3/2 valve (8):

- the chamber (C) of the slam-shut valve to be pressurised by the R44/SS regulator (6);
- the plug opening (1).

In the event that the slam-shut valve is required to trip, the pressure switch coupling system acts on the 3/2 valve to:

- discharge the pressure from the chamber (C) into the atmosphere through the 3/2 valve (8);
- allow the spring (10) to bring the plug (1) to the shut-off position.

4.5.4 - SLAM-SHUT VALVE PRESSURE SWITCHES

The pressure switch is a control device consisting of (see Fig. 4.10):

Pos.	Description
1	Control element. NOTICE! The control element can be a diaphragm or a piston.
2	Stem.
3-4	Adjustment feeler gauges
5	Spring for maximum pressure tripping.
6	Spring for minimum pressure tripping.
7	UPSO minimum spring adjustment nuts (6).
8	OPSO maximum spring adjustment nuts (5).
10	Manual release button.

Tab. 4.23.

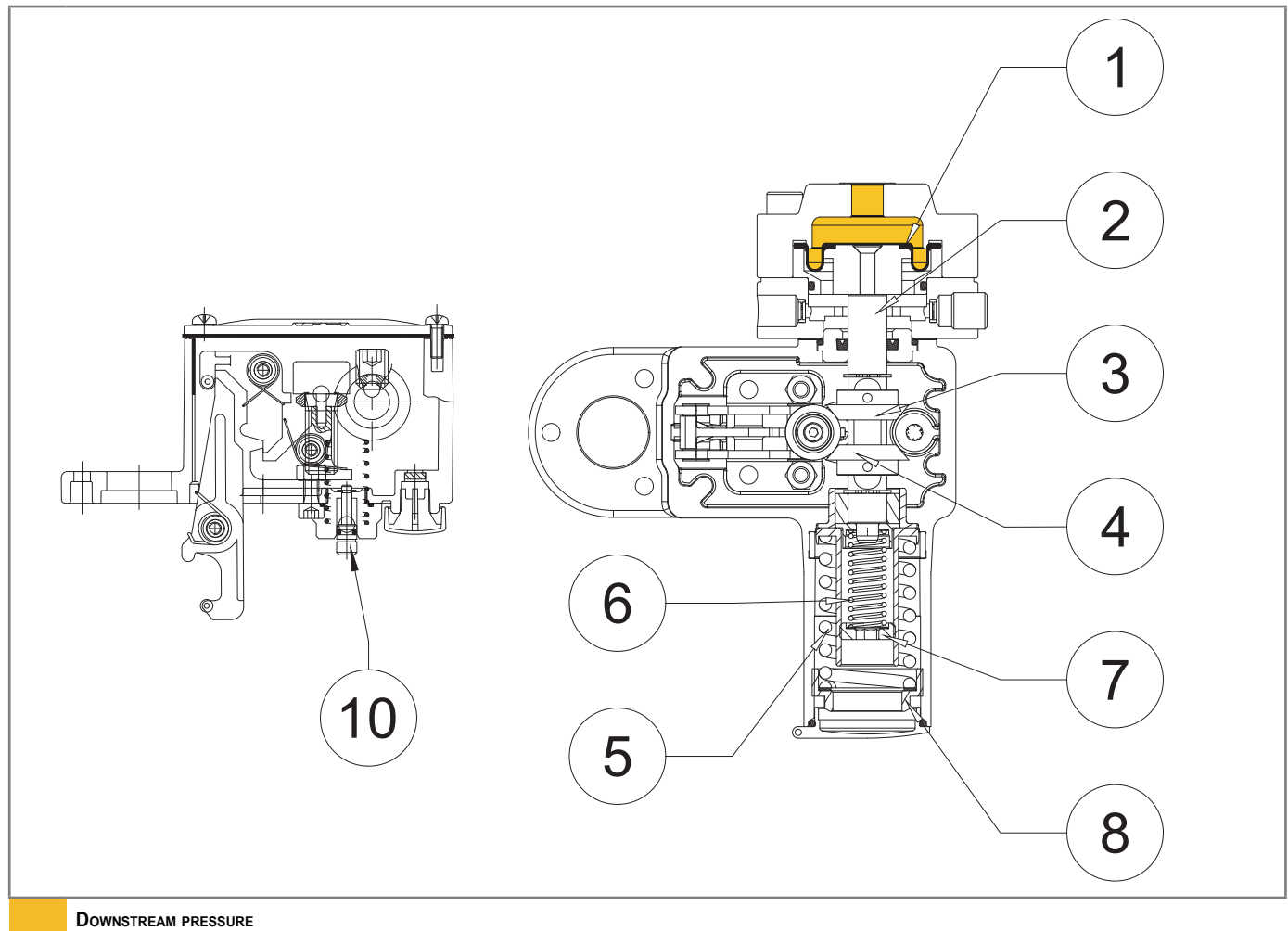

Fig. 4.10.

Slam-shut device pressure switch

Tab. 4.24 lists models of possible pressure switches for this slam shut valve:

Model pressure switch	Max [bar]	Min [bar]
102M	0.2 - 5.5	0.05 - 2.8
102MH	0.2 - 5.5	2.8 - 5.5
103M	2 - 22	0.2 - 8
103MH	2 - 22	8 - 19
104M	15 - 45	1.6 - 18
104MH	15 - 45	18 - 41
105M	30 - 90	3 - 44
105MH	30 - 90	44 - 90

Tab. 4.24.

PAGE INTENTIONALLY LEFT BLANK

5 - TRANSPORT AND HANDLING

5.1 - SPECIFIC WARNINGS FOR TRANSPORT AND HANDLING

NOTICE!

Transport and handling must be carried out by personnel:

- qualified (specially trained);
- who are familiar with accident prevention and workplace safety regulations;
- authorised to use lifting equipment and means;
- in compliance with the regulations in force in the country of destination of the equipment.

Transport with forklift or crane

Operator qualification	Person in charge of transport, handling, unloading and placing on site
PPE required	 <p>WARNING!</p> <p>The PPE listed in this table is related to the risk associated with the equipment. For the required PPE to protect against risks associated with the workplace, installation or operating conditions, please refer to:</p> <ul style="list-style-type: none"> • the regulations in force in the country of installation; • <u>any information provided by the Safety Manager at the installation facility.</u>
Means of lifting	Hoist crane, forklift truck or other suitable equipment.
Weights and dimensions of the equipment	For dimensions and weights please refer to “5.2 - Physical characteristics of the equipment”.

Tab. 5.25.

5.1.1 - PACKAGING AND FASTENERS USED FOR TRANSPORT

The transport packaging has been designed and manufactured to avoid damage during normal transport, storage and handling.

The equipment and spare parts must be kept in their packaging until they are installed.



Upon receiving the equipment:

- make sure that no part of the packaging has been damaged during transport and/or handling;
- immediately report any damage found to PIETRO FIORENTINI S.p.A..

! NOTICE!

PIETRO FIORENTINI S.p.A. shall not be liable for any damage to people or property caused by accidents due to failure to comply with the instructions provided in this manual.

Tab. 5.26 shows the types of packaging used:

Ref.	Type of packaging	Image
A	Cardboard box	
B	Wooden box	
C	Pallet	

Tab. 5.26.

PAGE INTENTIONALLY LEFT BLANK

5.2 - PHYSICAL CHARACTERISTICS OF THE EQUIPMENT

5.2.1 - ASX 176 (+LDB/176)

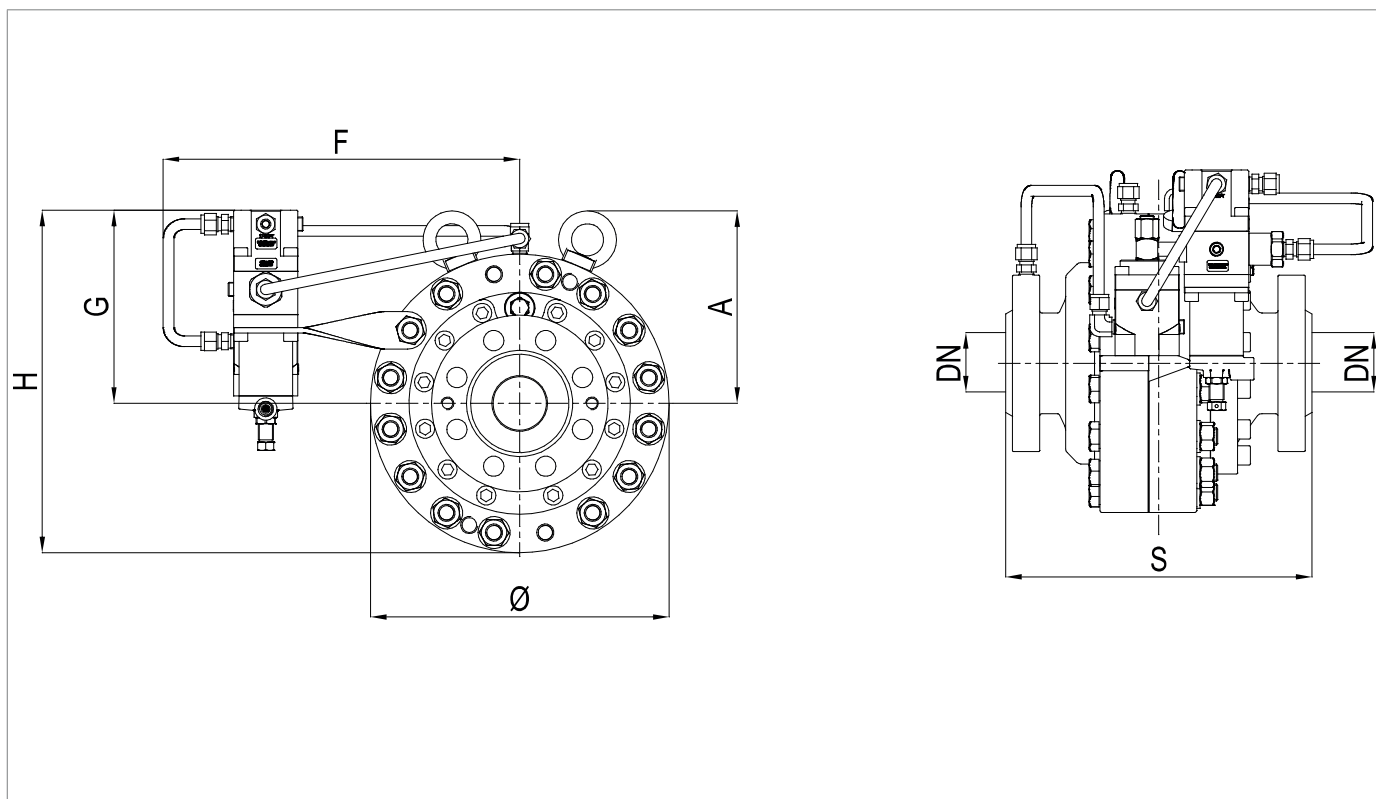

Fig. 5.11. Physical characteristics ASX 176 (+LDB/176)

Overall dimensions ASX 176					
Nominal diameter [mm]	25	50	80	100	150
Size [inches]	1"	2"	3"	4"	6"
S - Class 300	197	267	317	368	473
S - Class 600	210	286	336	394	508
Ø	279	279	359	440	550
A	180	180	223	263	318
F	335	335	375	409	465
G	181	181	186	203	201
H	321	321	365	425	476
Pneumatic connections	Øe 10mm x Øi 8mm				

Tab. 5.27.

Weights [kgf]					
Class 300	55	72	123	214	333
Class 600	55	74	126	225	365

Tab. 5.28.

5.2.2 - ASX 176 + PM/176

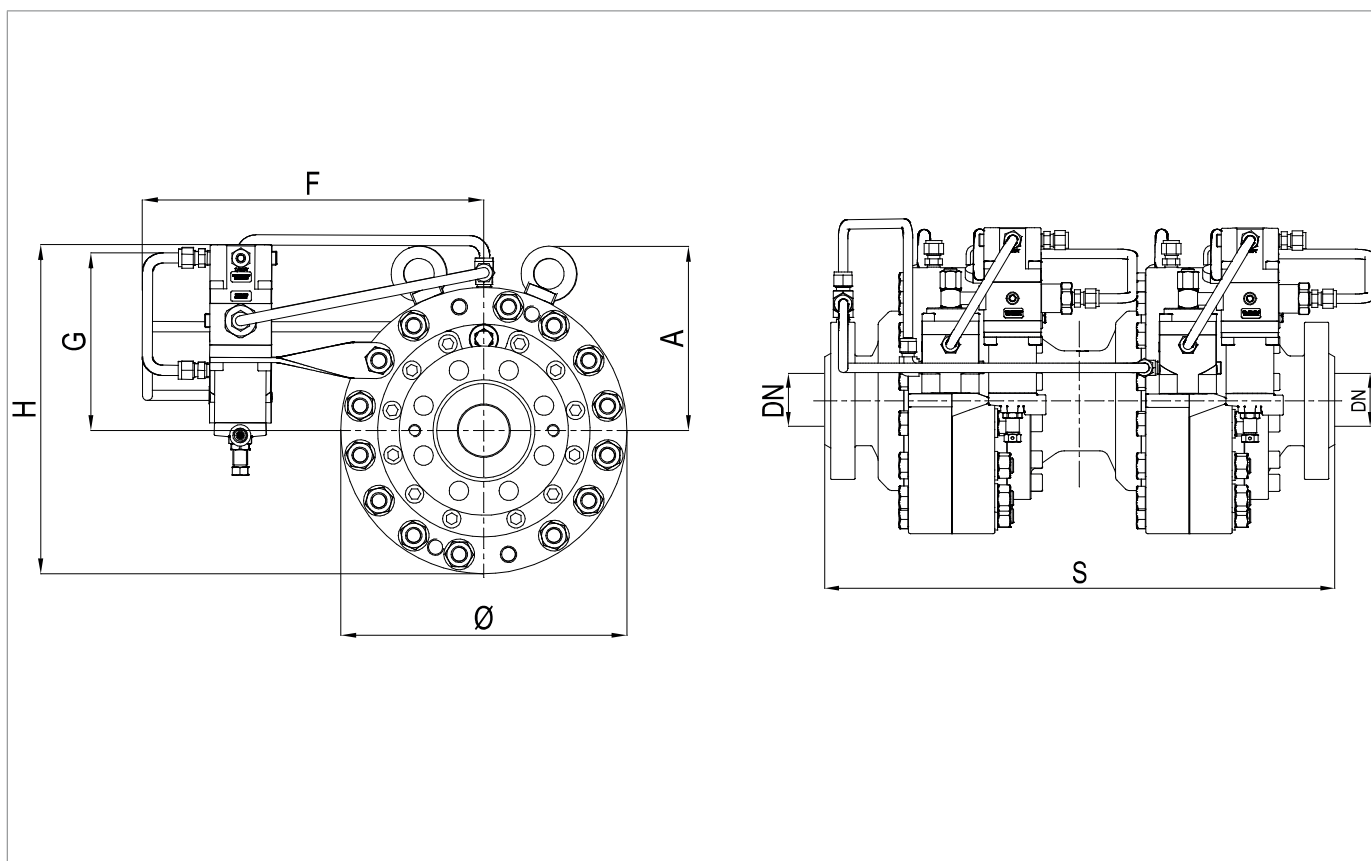

Fig. 5.12. ASX 176 + PM/176 physical characteristics

ASX 176 + PM/176 overall dimensions					
Nominal diameter [mm]	25	50	80	100	150
Size [inches]	1"	2"	3"	4"	6"
S - Class 300	372	516	581	694	901
S - Class 600	385	535	600	720	936
Ø	279	279	359	440	550
A	180	180	223	263	318
F	335	335	375	409	318
G	181	181	186	203	201
H	321	321	365	425	476
Pneumatic connections	Øe 10mm x Øi 8mm				

Tab. 5.29.

Weights [kgf]					
Class 300	110	137	239	425	656
Class 600	110	139	242	445	730

Tab. 5.30.

5.2.3 - ASX 176 + SSX/176

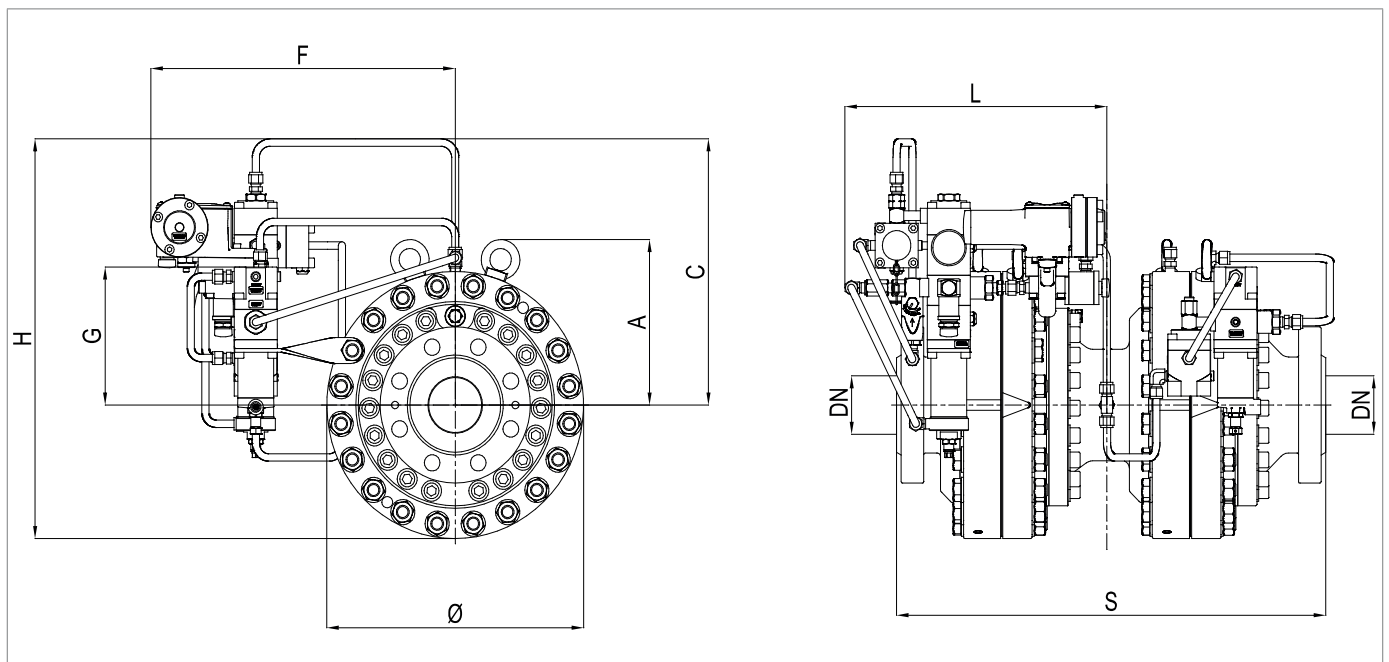

Fig. 5.13. Physical characteristics ASX 176 + SSX/176

Overall dimensions ASX 176 + SSX/176					
Nominal diameter [mm]	25	50	80	100	150
Size [inches]	1"	2"	3"	4"	6"
S - Class 300	372	516	581	694	901
S - Class 600	385	535	600	720	936
Ø	279	279	359	440	550
A	180	180	223	263	318
C	346	346	352	369	388
F	348	348	389	425	460
G	181	181	186	203	201
H	489	489	532	590	653
L	284	308	365	443	523
Pneumatic connections	Øe 10mm x Øi 8mm				

Tab. 5.31.

Weights [kgf]					
Class 300	115	142	244	429	661
Class 600	115	144	246	449	735

Tab. 5.32.

PAGE INTENTIONALLY LEFT BLANK

5.3 - EQUIPMENT ANCHORING AND LIFTING METHOD

 **HAZARD!**

Before handling the equipment, make sure that the capacity of the lifting equipment is suitable for the load.

 **WARNING!**

Unloading, transport and handling activities must be carried out by operators qualified and specially trained:

- on accident prevention rules;
- on maximum safety in the workplace;
- on the use of lifting equipment.

 **ATTENTION!**

Before handling the equipment:

- remove any movable or hanging component or firmly secure it to the load;
- protect the most fragile equipment;
- check that the load is stable.

5.3.1 - FORKLIFT HANDLING METHOD

HAZARD!

It is forbidden to:

- transit under suspended loads;
- move the load over the personnel operating in the site/plant area.

WARNING!





The following is not allowed on forklifts:

- carrying passengers;
- lifting people.

NOTICE!

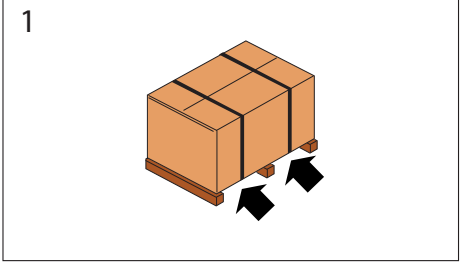
Packaging must be always handled in a vertical position

Proceed as shown in Tab. 5.33:

Step	Action	Image
1	Place the forks of the forklift under the load surface.	
2	Make sure that the forks protrude from the front of the load (by at least 5 cm), far enough to eliminate any risk of the transported load tipping.	
3	Raise the forks until they are touching the load. NOTICE! Fasten the load to the forks with clamps or similar devices if required.	
4	Slowly lift the load by a few dozen centimetres and check its stability, making sure that the centre of gravity of the load is at the centre of the lifting forks.	

Step	Action	Image
5	Tilt the mast backwards (towards the driver's seat) to help the over-turning moment and to ensure greater load stability during transport.	
6	Adjust transport speed according to the type of floor and load, avoiding jerky movements. ⚠ WARNING! If: <ul style="list-style-type: none"> • obstacles along the path; • particular operating situations; hinder operator visibility, the assistance of a ground operator is required, standing outside the range of action of the lifting equipment, with the task of signalling.	-
7	Place the load in the chosen installation area.	-

Tab. 5.33.

5.3.2 - CRANE HANDLING METHOD

⚠ WARNING!

It is mandatory to use chains, ropes and eyebolts CE marked or marked with conformity marks in accordance with the regulations in force in the place of installation. Do not use chains connected to each other by bolts.

Always check that:

- the safety catch of the hook returns to the initial position;
- the ropes are in excellent condition and have adequate sections.

It is forbidden to:

- drag the load on the ground;
- operate near power lines;
- stand within the range of action of the crane.

! NOTICE!

Packaging must be always handled in a vertical position.

The equipment must be handled using the lifting points provided on the equipment itself. For proper transport, follow the procedure in Tab. 5.34:

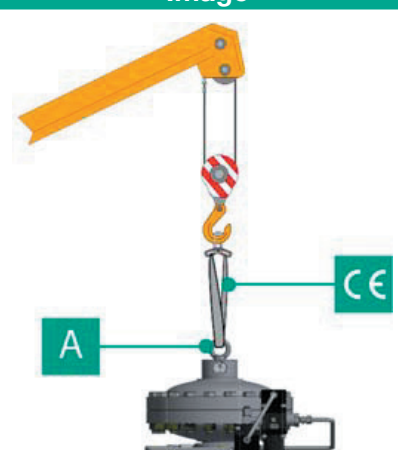
Step	Action	Image
1	Attach the lifting rope or chain to the appropriate supports. <div style="background-color: #f4a460; padding: 5px; border: 1px solid #0070c0;"> <p>⚠ WARNING! The lifting point is sized for lifting only the equipment, and not other parts of the system connected to it.</p> </div>	
2	Slightly lift the load making sure the ropes or chains are secure. <div style="border: 1px solid #0070c0; padding: 5px;"> <p>! NOTICE! Check whether the load is properly balanced.</p> </div>	
3	Handle the load avoiding sudden movements.	
4	Place the load in the chosen installation area.	

Tab. 5.34.

5.4 - PACKAGING REMOVAL

Packaging removal	
Operator qualification	<ul style="list-style-type: none"> Person in charge of transport, handling, unloading and placing on site; Installer.
PPE required	 <p>WARNING!</p> <p>The PPE listed in this table is related to the risk associated with the equipment. For the PPE necessary to protect against risks associated with the workplace or operating conditions, please refer to:</p> <ul style="list-style-type: none"> the regulations in force in the country of installation; any information provided by the Safety Manager at the installation facility.

Tab. 5.35.

To unpack equipment in a cardboard boxes, proceed as in :Tab. 5.36

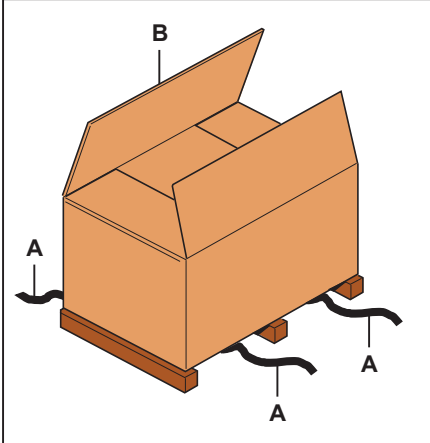
Step	Action	Image
1	Remove the straps (A).	
2	Remove the packaging cardboard (B).	
3	Remove the fasteners that secure the equipment to the base (if any).	
4	<p>Move the equipment from the base to the place intended for it.</p> <p>NOTICE!</p> <p>Have at least 2 operators manually move the equipment, if required due to its dimensions/weight.</p>	

Tab. 5.36.

NOTICE!

After removing all packaging materials, check for any anomalies.

If there are anomalies:

- do not install the equipment;
- contact PIETRO FIORENTINI S.p.A. and specify the details provided on the equipment rating plate.

5.4.1 - PACKAGING DISPOSAL

NOTICE!

Sort the various materials making up the packaging and dispose of them in compliance with the regulations in force in the country of installation.

5.5 - STORAGE AND ENVIRONMENTAL CONDITIONS

If the equipment needs to be stored for an extended period, the minimum environmental conditions for the intended storage are provided. Only by complying with these requirements can the declared performance be guaranteed:

Conditions	Data
Maximum storage period	Maximum 3 years.
	 NOTICE! For installations in later periods, see paragraph “pre-installation warnings after prolonged storage.”
Temperature	Not above 40°C
Humidity	Not above 70%
Radiation	Away from radiation sources according to UNI ISO 2230:2009

Tab. 5.37.

5.5.1 - PRE-INSTALLATION WARNINGS AFTER PROLONGED STORAGE

For installations that have been stored for longer than 3 years, the condition of all rubber parts must be checked and, if found to be damaged, they must be replaced in order to ensure the correct functioning of the equipment.

For the replacement of the rubber parts of the equipment, please refer to chapter “9 - Maintenance and functional checks”.

 NOTICE! PIETRO FIORENTINI S.p.A. recommends checking the condition of rubber parts in case of downtime or storage longer than 3 years.
--

PAGE INTENTIONALLY LEFT BLANK

6 - INSTALLATION

6.1 - INSTALLATION PRE-REQUISITES

6.1.1 - ENVIRONMENTAL CONDITIONS ALLOWED

WARNING!

To safely use the equipment, in full respect of the allowed environmental conditions, follow the data shown on the regulator plate and on any accessories (refer to paragraph “2.8 - Applied rating plates”).

The installation site must be suitable for the safe use of the equipment.

The equipment installation area must have lighting that guarantees the operator good visibility during the work phases on the equipment.

NOTICE!

The equipment must operate in places that are properly lit by artificial lighting suitable for the protection of the operator (in compliance with UNI EN 12464-1:2011 and UNI EN 12464-2:2014). If maintenance work is to be performed in areas and/or parts that are poorly lit, it is mandatory to:

- use all the light sources of the installation plant;
- be equipped with a handheld lighting system or connected to the power mains, compliant with Directive 2014/34/EU (ATEX) for use in environments at risk of explosion.

6.1.2 - CHECKS BEFORE INSTALLATION

The device does not require any further upstream safety device for protection against any overpressure with respect to its **PS admissible pressure** when, for the upstream reduction station, the maximum incidental downstream pressure is:

$$\text{MIPd} \leq 1.1 \text{ PS}$$

MIPd = Maximum incidental downstream pressure value (for further information, see UNI EN 12186:2014).

ATTENTION!







If the installation of the equipment requires the application of compression fittings, these must be installed in accordance with the instructions of the Manufacturer of the fittings themselves.

The choice of fittings must be compatible with:

- **the use specified for the equipment;**
- **the plant specifications when required.**

Before installation, it must be ensured that:

- the expected dimensions of the installation site are compatible with those of the equipment;
- there are no impediments for the workers in charge of maintenance;
- the upstream and downstream pipes are at the same level and can bear the weight of the equipment;
- the inlet and outlet connections of the pipes are aligned on the flanges;
- the inlet and outlet connections of the equipment are clean and intact;
- the inside of the upstream pipe is clean and free of processing residues such as welding slag, sand, paint residues, water, etc...

Installation	
Operator qualification	Installer
PPE required	<div style="display: flex; align-items: center; gap: 10px;">      </div> <div style="background-color: #ff8c00; padding: 5px; margin-top: 5px;">  WARNING! </div> <p>The PPE listed in this table is related to the risk associated with the equipment. For the required PPE to protect against risks associated with the workplace, installation or operating conditions, please refer to:</p> <ul style="list-style-type: none"> • the regulations in force in the country of installation; • any information provided by the Safety Manager at the installation facility.
Equipment required	Refer to chapter 7 'Equipment for commissioning/maintenance'.

Tab. 6.38.

6.2 - SPECIFIC SAFETY INSTRUCTIONS FOR THE INSTALLATION PHASE

 **WARNING!**

Before proceeding with installation, make sure that the upstream and downstream valves installed on the line are shut off.

 **WARNING!**

Installation may also take place in areas where there is a risk of explosion, which implies that all necessary prevention and protection measures have to be taken.

For these measures, please refer to the regulations in force at the place of installation.

6.3 - GENERAL INFORMATION ON CONNECTIONS

The equipment must be installed in-line with an arrow on the body pointing to the gas flow direction. In line installation and squared installation there must be the following (see Fig. 6.14 and Fig. 6.15):

Pos.	Description
1	1 slam shut valve upstream of the equipment
2	2 vent valves set up one upstream and one downstream of the equipment.
3	2 pressure gauges set up one upstream and one downstream of the equipment.
4	1 pressure regulator .
5	1 shut-off valve downstream of the equipment.

Tab. 6.39.

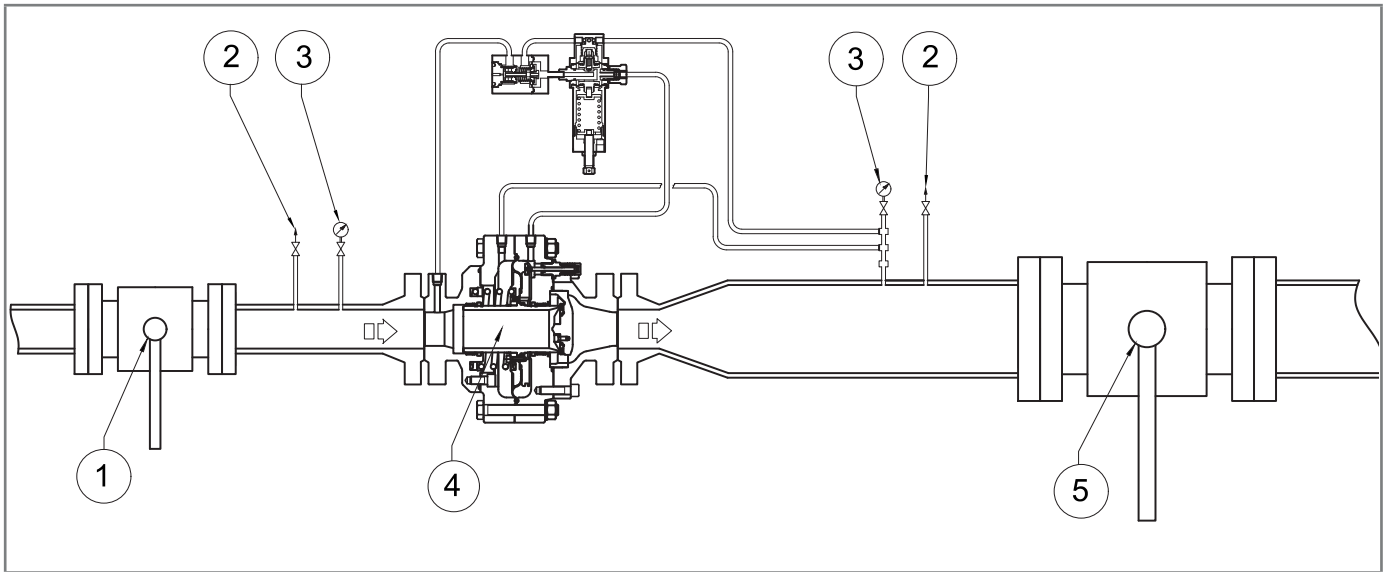

Fig. 6.14. Inline installation

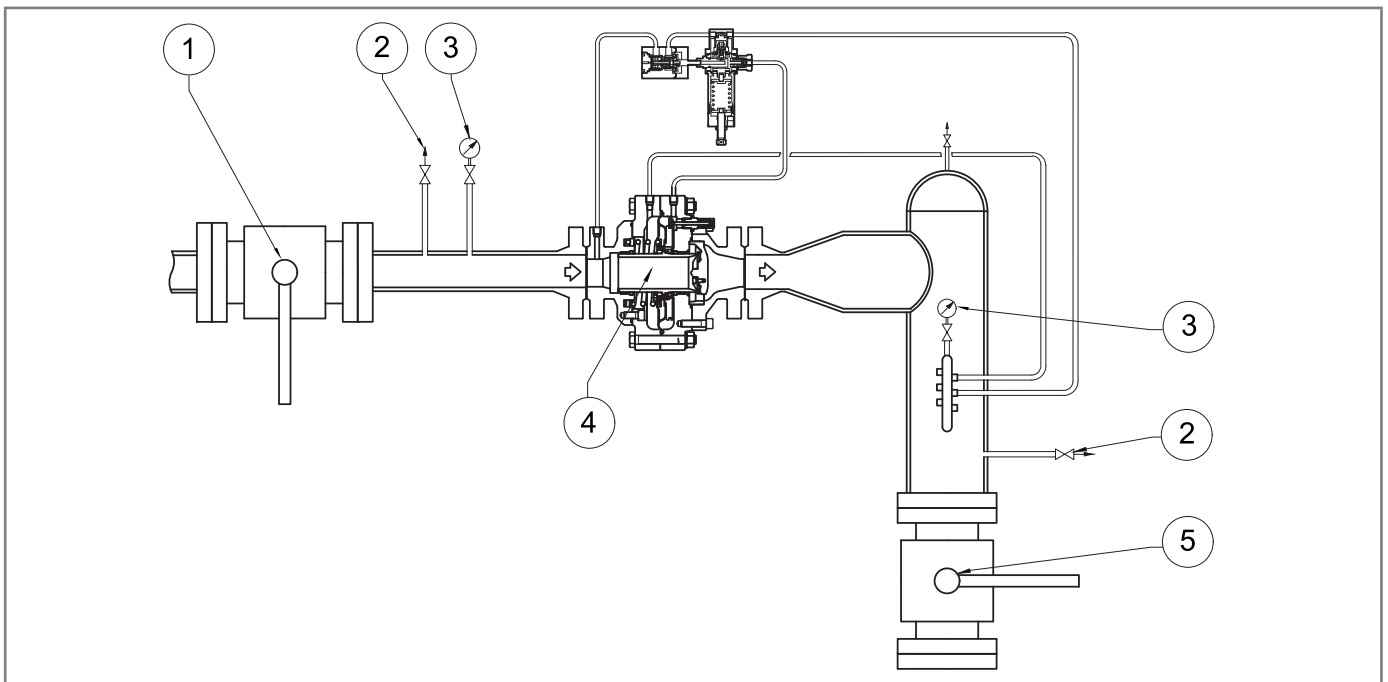

Fig. 6.15. Angle installation

! NOTICE!

When used in gas pressure reduction stations, the device must be installed at least according to the requirements of standards UNI EN 12186:2014 or UNI EN 12279:2007.

Equipment vents must be ducted in accordance with UNI EN 12186:2014 or UNI EN 12279:2007 or the standards in force at the place of installation of the equipment.

6.4 - REGULATOR INSTALLATION POSITIONS

Fig. 6.16 and Fig. 6.17 illustrate the possible regulator arrangements:

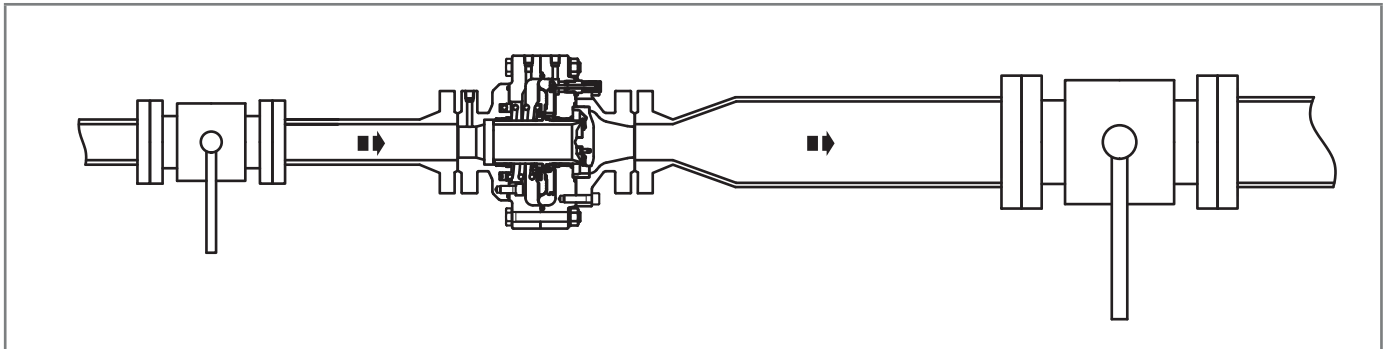

Fig. 6.16. Horizontal position

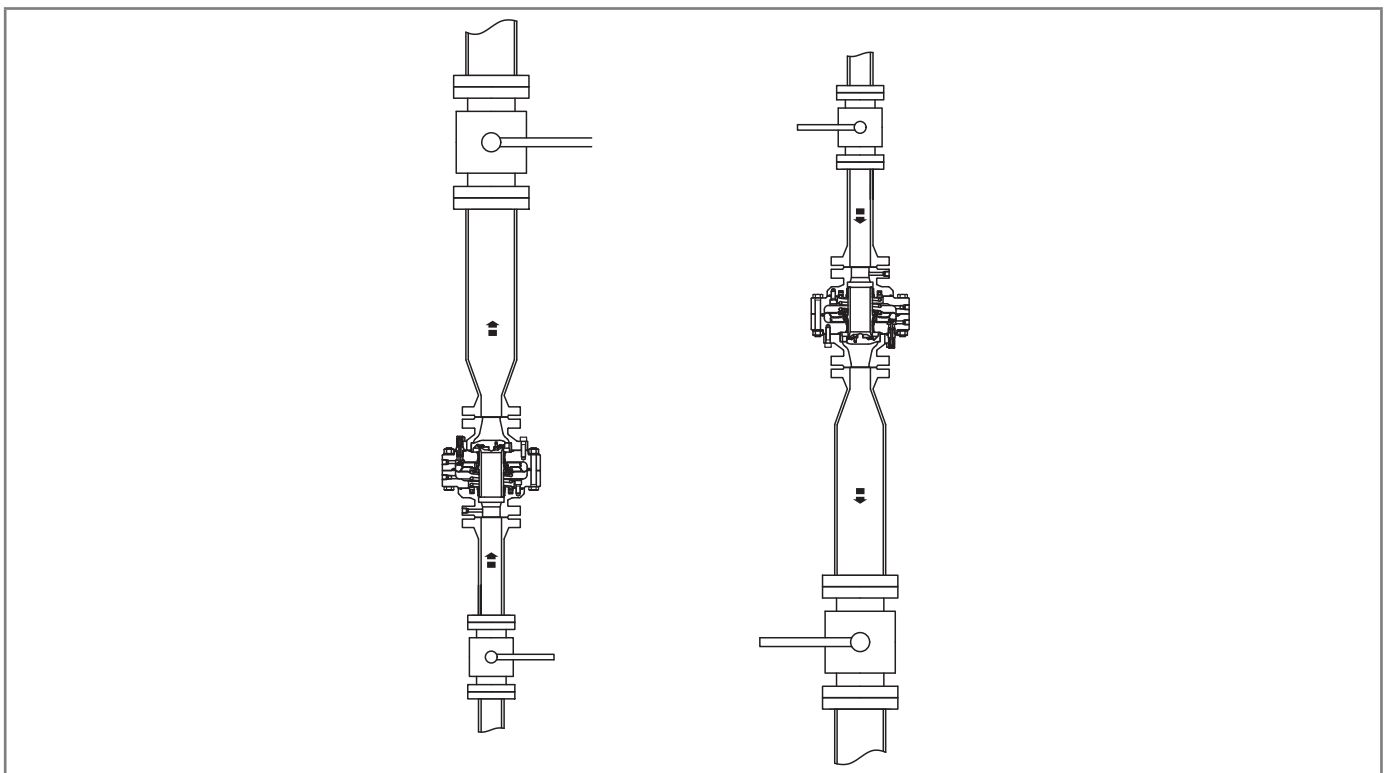

Fig. 6.17. Vertical position with flow direction from bottom to top (left) or top to bottom (right)

6.5 - EQUIPMENT INSTALLATION PROCEDURE

6.5.1 - IN-LINE EQUIPMENT INSTALLATION PROCEDURE

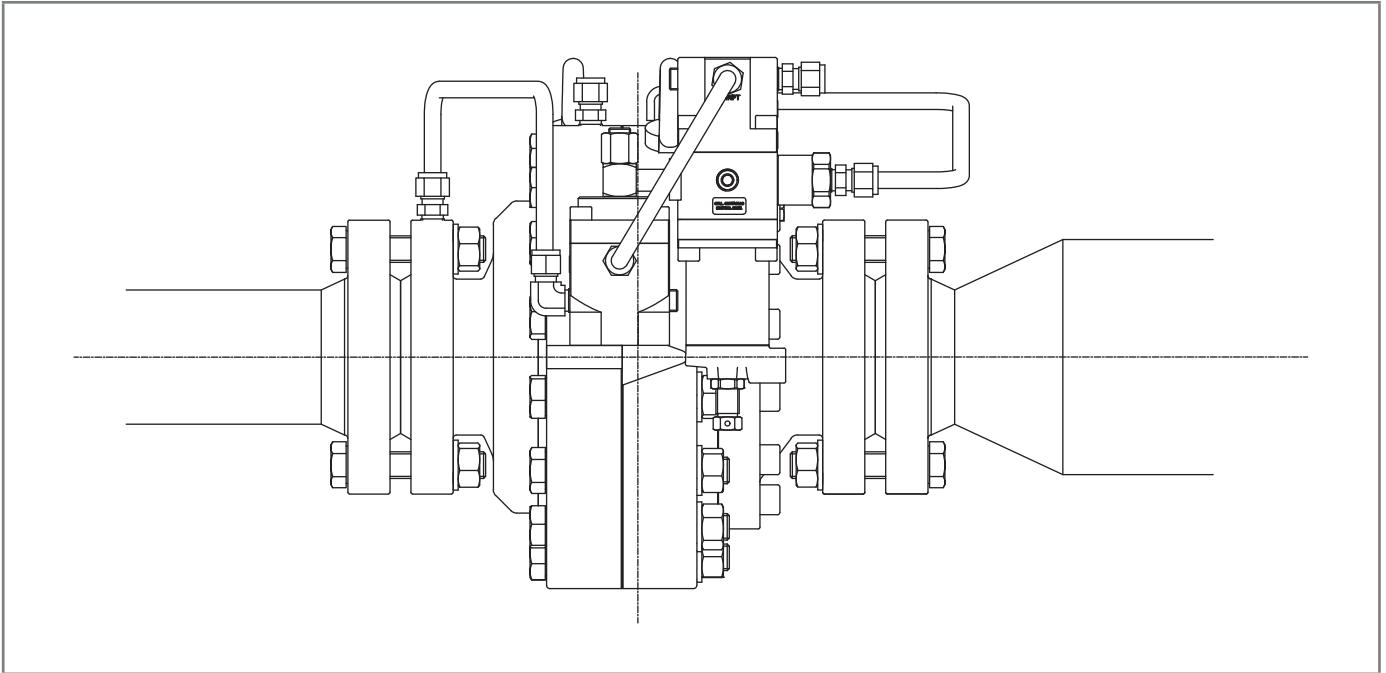

Fig. 6.18. ASX 176 installation without spacer

Step	Action
1	Place the equipment in the section of the line designated for it.
2	Place the gaskets between the line flanges and the regulator flanges.
3	Insert the bolts into the appropriate holes of the connecting flanges.
4	Screw the bolts following the technical rules for tightening flanges.

Tab. 6.40.

! NOTICE!

For installation after maintenance, replace the gaskets and clean the flange bearing surface.

6.5.2 - INSTALLATION PROCEDURE FOR IN-LINE EQUIPMENT WITH SPACER

It is possible to install the equipment by inserting a spacer. This configuration is used to service the reinforced gasket without removing the regulator from the line.

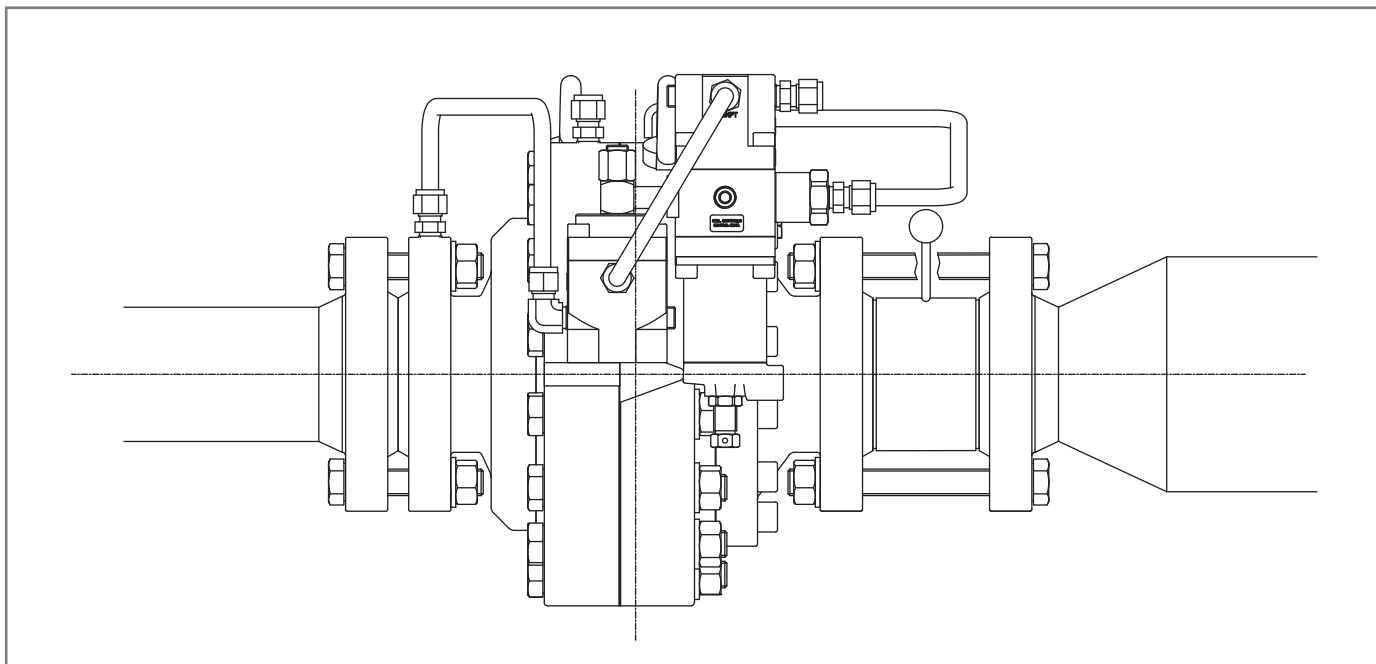

Fig. 6.19. ASX 176 installation with spacer

Step	Action
1	Place the equipment in the section of the line designated for it.
2	Place the gaskets between the line flange and the upstream regulator flange.
3	Insert the bolts into the appropriate holes of the upstream connecting flanges.
4	Place a gasket between the spacer and the regulator.
5	Place a gasket between the spacer and the downstream pipe flange.
6	Insert the bolts into the appropriate holes of the downstream connecting flanges.
7	Screw the bolts following the technical rules for tightening flanges.

Tab. 6.41.

NOTICE!

For installation after maintenance, replace the gaskets and clean the flange bearing surface.

Tab. 6.42 lists the dimensions of the mounting spacer:

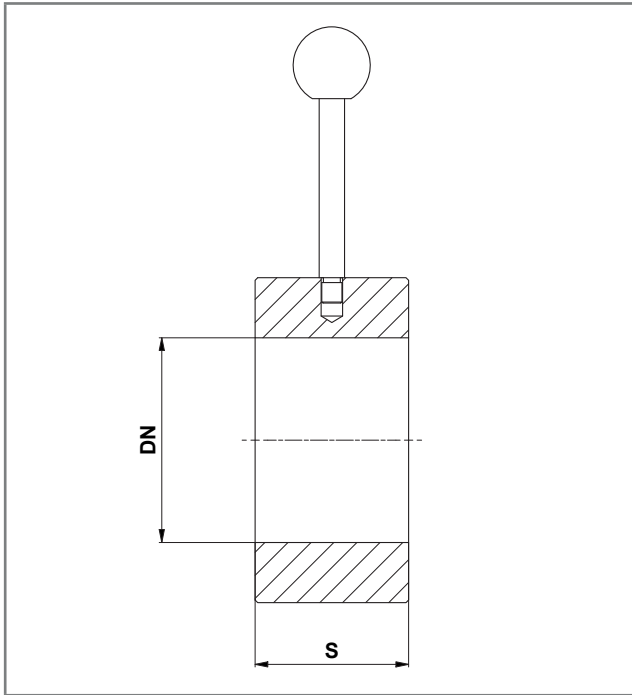

Fig. 6.20. Mounting spacer

DN	S
25	30
50	50
80	60
100	60
150	80

Tab. 6.42.

6.5.3 - CONNECTION OF THE SENSING LINES TO THE DOWNSTREAM PIPING

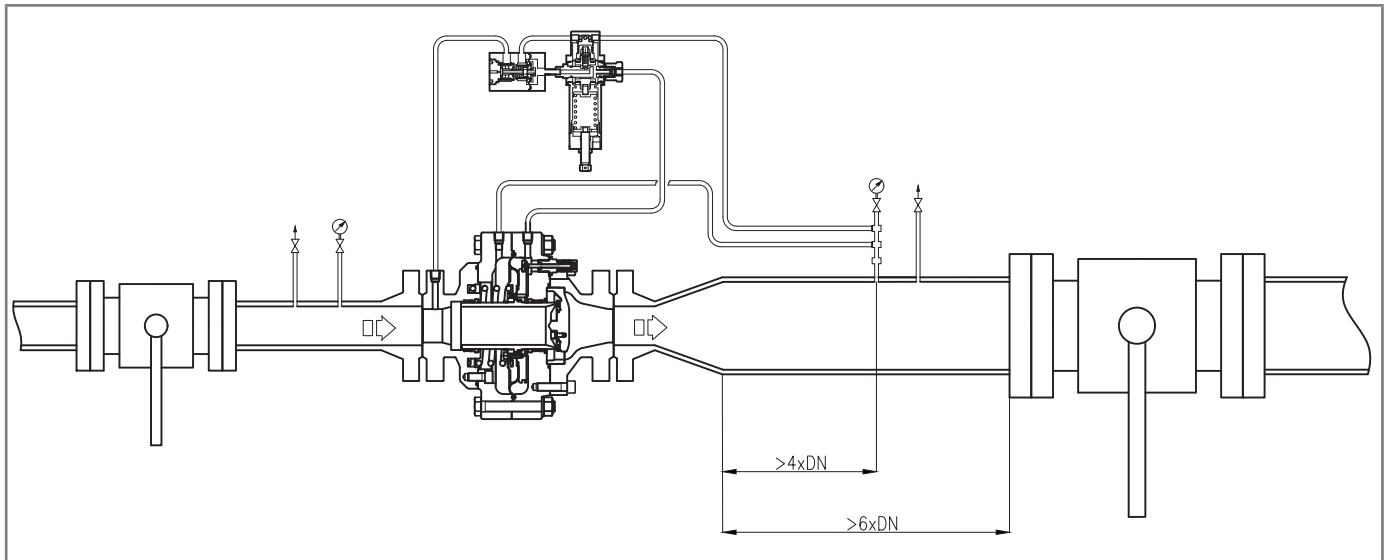

Fig. 6.21. Connection of sensing lines to the downstream piping

For proper adjustment, it is essential that:

- the downstream shut-off valve is placed at a distance of at least 6 times the nominal diameter of the pipe downstream of the regulator;
- the downstream sensing lines are placed on a straight section of pipe (with uniform diameter) having a length equal to at least 4 times the rated diameter of the pipe itself.

⚠ ATTENTION!

The pilot drain must not be connected to the multi-socket switch.

For optimum performance, the velocity of the pressurised fluid at the intake point should not exceed the following values:

- $V_{max} = 30 \text{ m/s}$ for $P_a > 5 \text{ bar}$
- $V_{max} = 25 \text{ m/s}$ for $P_a < 5 \text{ bar}$

As a limitation of use, the velocity of the pressurised fluid at the intake point does not exceed the following values:

- $V_{max} = 30 \text{ m/s}$ for $P_a > 5 \text{ bar}$

To calculate the flow rate, use the following formula:

$$V = 345,92 \times \frac{Q}{DN^2} \times \frac{1 - 0,002 \times Pd}{1 + Pd}$$

V = gas velocity in m/sec

Q = gas flow rate in Sm^3/h

DN = nominal diameter of the regulator in mm

Pd = regulator outlet pressure in barg

⚠ NOTICE!

All pneumatic connections to be made on site must have a minimum internal diameter of 8 mm.

To prevent the pneumatic connections of the sensing lines from collecting impurities and condensation, it is necessary that:

- the pneumatic connection fittings are always welded to the top or at most 90° on the axis of the pipe itself (refer to Fig. 6.22);
- the hole in the piping has no burrs or internal protrusions;
- the slope of the pneumatic connection is always 5-10% towards the downstream pipe fitting.

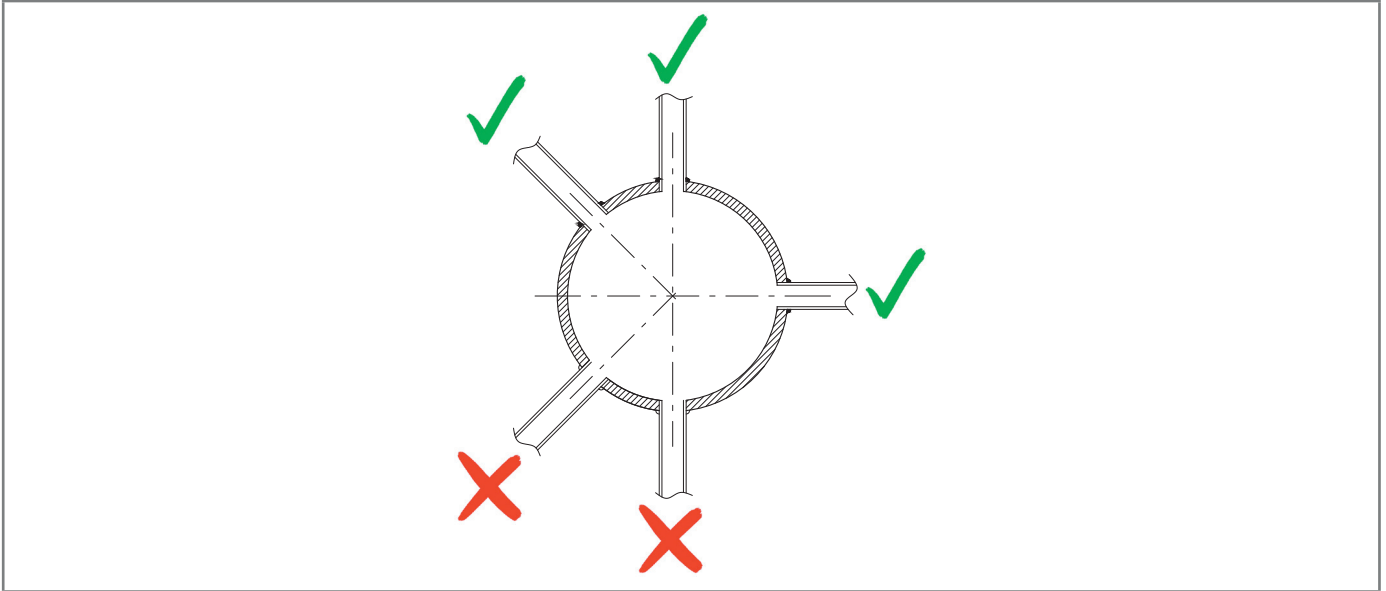

Fig. 6.22.

Welded connections of the pneumatic connection

If there is a multiple sensing line (see Fig. 6.23), connect the equipment connections as shown below:

- 1 and 2 to the discharge outlet of the regulator control head and PM/176 monitor if any;
- 3 and 4 to the pilot sensing lines;
- 5 and 6 to the sensing lines of the throttle and/or of the slam-shut device, if any.

! NOTICE!

If there is a multiple sensing line, it is not recommended to place shut-off valves on sensing lines. In any case, follow the regulations in force in the place of installation and use of the equipment.

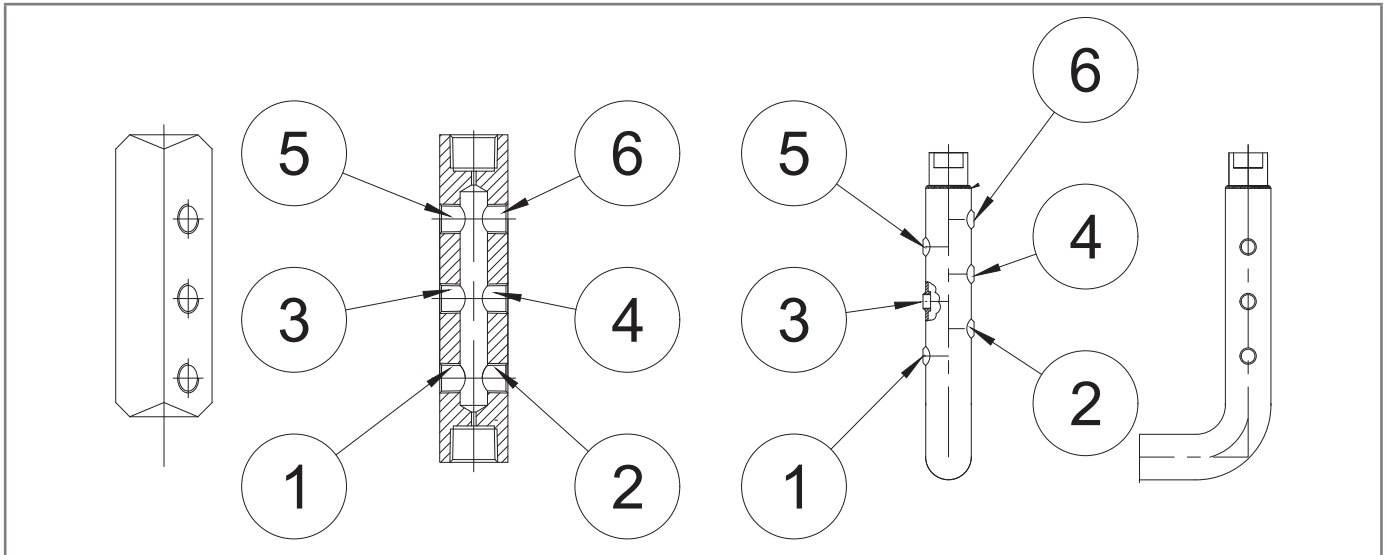

Fig. 6.23. Equipment connections

6.6 - POST-INSTALLATION AND PRE-COMMISSIONING CHECKS

When the equipment is operating, make sure that all connections are:

- properly secured/tightened to prevent any leakage during commissioning;
- connected correctly.

PAGE INTENTIONALLY LEFT BLANK





7 - COMMISSIONING/MAINTENANCE EQUIPMENT

7.1 - LIST OF EQUIPMENT

Use of commissioning/maintenance equipment	
Operator qualification	<ul style="list-style-type: none"> • Mechanical maintenance technician; • Electrical maintenance technician; • Installer; • User technician.
PPE required	<div style="display: flex; align-items: center;">  </div> <div style="background-color: #f4a460; padding: 5px; margin-top: 5px;"> ⚠ WARNING! </div> <p>The PPE listed in this table is related to the risk associated with the equipment. For the required PPE to protect against risks associated with the workplace, installation or operating conditions, please refer to:</p> <ul style="list-style-type: none"> • the regulations in force in the country of installation; • any information provided by the Safety Manager at the installation facility.

Tab. 7.43.

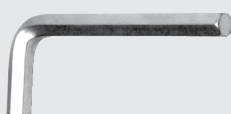
The types of equipment required to commission and service the equipment are described in Tab. 7.44:

Ref.	Equipment type	Image
A	Combination wrench	
B	Adjustable wrench	
C	Double ended bi-hex tubular socket wrench	
D	Bent male hex wrench	
E	Male hex T-key	

Ref.	Equipment type	Image
F	O-ring extraction tool	
G	Fiorentini special tool	

Tab. 7.44.

7.2 - EQUIPMENT NEEDED FOR THE DIFFERENT CONFIGURATIONS

Each table is distinguished by:

Term	Description
K./Wr.	Key, with reference to the equipment indicated in Tab. 7.44.
Code	Code, referring to the equipment.
DN	Indicates the Nominal Diameter of the reference configuration.
L.	Length, referring to the equipment.
Ref.	Reference to the equipment.
Type	Type (size) or code of the equipment.

Tab. 7.45.

ASX 176 (+ LDB/176)						
Equipment		Size [inches]				
Ref.	Type	1"	2"	3"	4"	6"
A	K./Wr.	13-17-19- 24-30	13-17-19- 24-30	13-17-19- 24-27-30	13-17-19- 24-30-32	13-17-19- 24-30-41
B	L.	300				
C	K./Wr.	17	17	17	17	17
D	K./Wr.	10	10	14	14	14
E	K./Wr.	5-6-7	5-6-7	5-6-7	5-6-7	5-6-7
F	Code	7999099				

Tab. 7.46.

ASX 176 + PM/176						
Equipment		Size [inches]				
Ref.	Type	1"	2"	3"	4"	6"
A	K./Wr.	13-17-19- 24-30	13-17-19- 24-30	13-17-19- 24-27-30	13-17-19- 24-30-32	13-17-19- 24-30-41
B	L.	300				
C	K./Wr.	17	17	17	17	17
D	K./Wr.	10	10	14	14	14
E	K./Wr.	5-6-7	5-6-7	5-6-7	5-6-7	5-6-7
F	Code	7999099				

Tab. 7.47.

ASX 176 + SSX/176						
Equipment		Size [inches]				
Ref.	Type	1"	2"	3"	4"	6"
A	K./Wr.	13-17-19- 24-30	13-17-19- 24-30	13-17-19- 24-27-30	13-17-19- 24-30-32	13-17-19- 24-30-41
B	L.	300				
C	K./Wr.	17	17	17	17	17
D	K./Wr.	10	10	14	14	14
E	K./Wr.	5-6-7	5-6-7	5-6-7	5-6-7	5-6-7
F	Code	7999099				
G	Code	7999097				

Tab. 7.48.

PAGE INTENTIONALLY LEFT BLANK

8 - COMMISSIONING

8.1 - GENERAL WARNINGS

8.1.1 - SAFETY REQUIREMENTS FOR COMMISSIONING

HAZARD!

During commissioning the risks associated with any discharges to the atmosphere of flammable or noxious gases must be evaluated.

HAZARD!

In case of installation on distribution networks for natural gas, consider the risk associated with explosive mixtures (gas/air) being formed inside the piping, if the line is not subjected to inerting.

WARNING!

During commissioning, any unauthorised personnel must keep away.
The 'no entry' area has to be marked with signs and/or boundaries.

NOTICE!

Commissioning has to be carried out by authorised and qualified personnel.

The equipment is supplied with the pilot unit already calibrated.

Even if the built-in monitor PM/176 or the built-in slam-shut valve SSX/176 is fitted to the equipment, any pilots or pressure switches present will be already calibrated.



NOTICE!

The calibration of the equipment accessories may vary due to external causes (e.g. vibration during transport), while remaining within the values indicated on the nameplates.

Before commissioning the equipment, it is necessary to check that:

- all shut-off valves (inlet, outlet, any bypass) are closed;
- the gas is at a temperature within the limits specified on the data plate.

Commissioning

Operator qualification	<ul style="list-style-type: none"> • Installer; • Qualified technician.
PPE required	 <p> WARNING!</p> <p>The PPE listed in this table is related to the risk associated with the equipment. For the required PPE to protect against risks associated with the workplace, installation or operating conditions, please refer to:</p> <ul style="list-style-type: none"> • the regulations in force in the country of installation; • <u>any information provided by the Safety Manager at the installation facility.</u>
Equipment required	Please refer to the chapter "7 - Commissioning/maintenance equipment".

Tab. 8.49.

8.2 - PRELIMINARY PROCEDURES FOR COMMISSIONING

HAZARD!

Before commissioning the equipment, it must be ensured that any source of explosion has been eliminated if there is such a danger.

WARNING!

Before commissioning, you need to make sure that the characteristics of the equipment are suitable for the conditions of use.

ATTENTION!

To protect the equipment from damage, the following operations must never be carried out:

- pressurisation through a valve located downstream of the equipment;
- depressurise the equipment through a valve located upstream of it.

Commissioning can be carried out using two different procedures:

Commissioning types

Injection of an inert fluid	Pressurising the equipment by injecting an inert fluid (e.g. nitrogen) to avoid potentially explosive mixtures for services with combustible gases. <div style="background-color: #f4a460; padding: 5px; margin-top: 5px;">  WARNING! During pressurisation, always check that the equipment has no leaks. </div>
Direct injection	Direct injection of gas into pipes, keeping the gas velocity in the pipes as low as possible (maximum permitted value of 5 m/s).

Tab. 8.50.

8.3 - PROPER COMMISSIONING CHECK

Completely sprinkle the equipment (or equivalent control system) with a foaming solution in order to check the tightness of the regulator's external surfaces and of the connections made during installation.

8.4 - CALIBRATION OF ANY ACCESSORIES

To carry out a correct calibration of all accessories in the equipment, refer to Tab. 8.51 where starting with the calibration of the controller, all values are defined:

Calibration of a line consisting of: ASX 176 + PM/176 Incorporated monitor or SSX/176 slam-shut valve				
Calibration REGULATOR (Pd) bar	Calibration MONITOR	Calibration ACCELERATOR	Calibration Max pressure SLAM-SHUT DE- VICE	Calibration Min pressure SLAM-SHUT DE- VICE
0.8 ÷ 2.1	Pd x 1.1	Pd x 1.2	Pd x 1.5	Pd - 0.3 bar
2.1 ÷ 5	Pd x 1.1	Pd x 1.2	Pd x 1.4	Pd - 0.5 bar
5 - 25	Pd x 1.05	Pd x 1.1	Pd x 1.3	Pd - 3 bar
25 - 60	Pd x 1.03	Pd x 1.06	Pd x 1.3	Pd - 5 bar

Tab. 8.51.

8.5 - REGULATOR COMMISSIONING PROCEDURE

In the application consisting of multiple pressure adjusting lines, it is advisable to commission one line at a time, starting with the line with the lowest set point.

The set point value is mentioned on the test certificate enclosed with each piece of equipment.

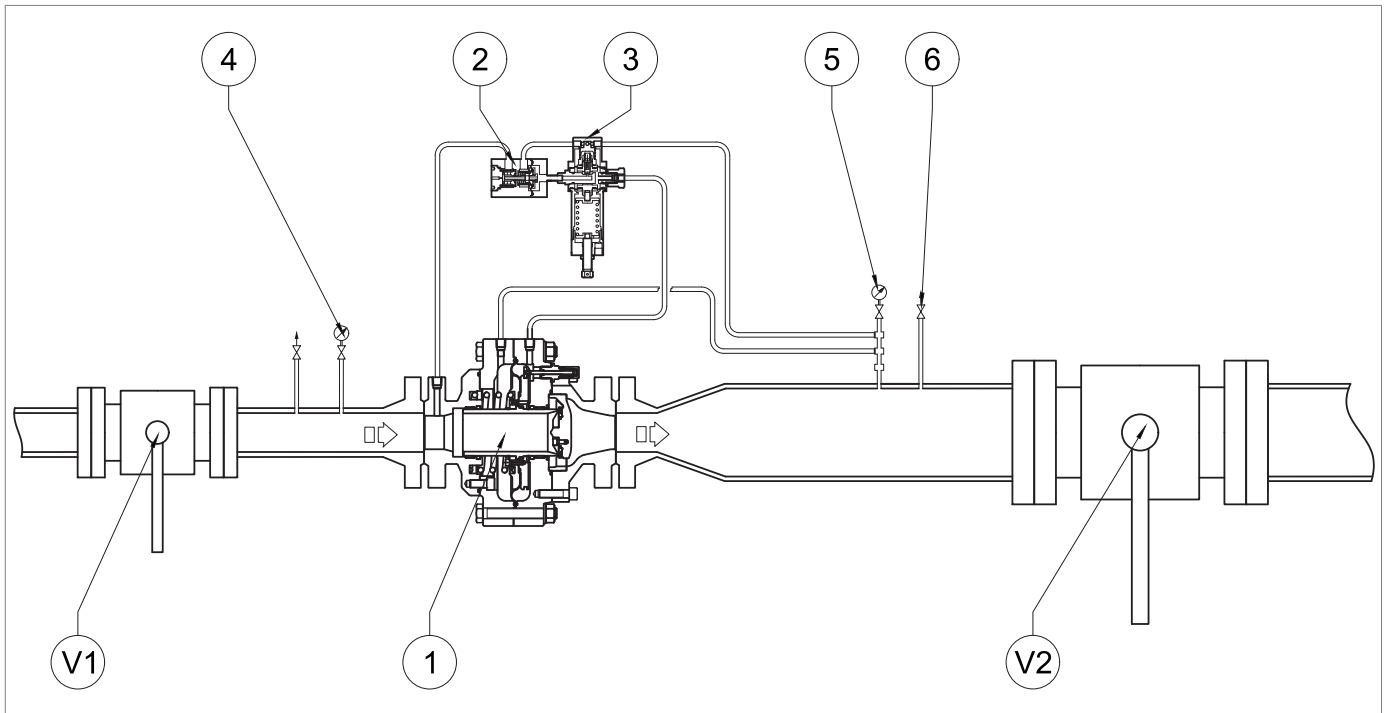

Fig. 8.24.

Commissioning the regulator ASX 176

Step	Action
1	Partially open the air vent valve (6).
2	Completely unscrew the fixing nut and adjusting screw (Fig. 8.30) of the pilot (3) to relieve the spring.
3	<p>Open the upstream shut-off valve (V1) very slowly.</p> <p>! NOTICE!</p> <p>Check the pressure by referring to the pressure gauge (4) located upstream.</p>
4	<p>Turn the pilot adjusting screw (3) clockwise to load the calibration spring until the pre-set downstream pressure value has been reached.</p> <p>! NOTICE!</p> <p>Check the pressure referring to the pressure gauge (5) located upstream.</p>
5	Close the bleed cock (6).
6	<p>Check that the downstream pressure, after an increase phase, does not exceed the shut-off pressure value (refer to the SG value on the nameplate, see paragraph 2.8).</p> <p>! NOTICE!</p> <ul style="list-style-type: none"> • If the downstream pressure exceeds the closing pressure value, refer to chapter “10 - Troubleshooting” to clear the causes of the malfunctions. • Check the pressure referring to the pressure gauge (5) located upstream.
7	<p>Check the tightness of all the fittings between the shut-off valves (V1, V2).</p> <p>! NOTICE!</p> <p>Check for sealing with a foaming substance.</p>
8	<p>Open the downstream shut-off valve (V2) very slowly until the piping has been filled completely.</p> <p>! NOTICE!</p> <p>If at the beginning of this operation, the pressure in the downstream pipeline is much lower than the calibration pressure, split the opening of this valve so as not to exceed the maximum flow rate of the system.</p>
9	Insert and secure the adjusting screw with the fixing nut (Fig. 8.30) of the pilot (3).

Tab. 8.52.

8.6 - COMMISSIONING PROCEDURE FOR THE ASX 176 REGULATOR WITH BUILT-IN MONITOR PM/176

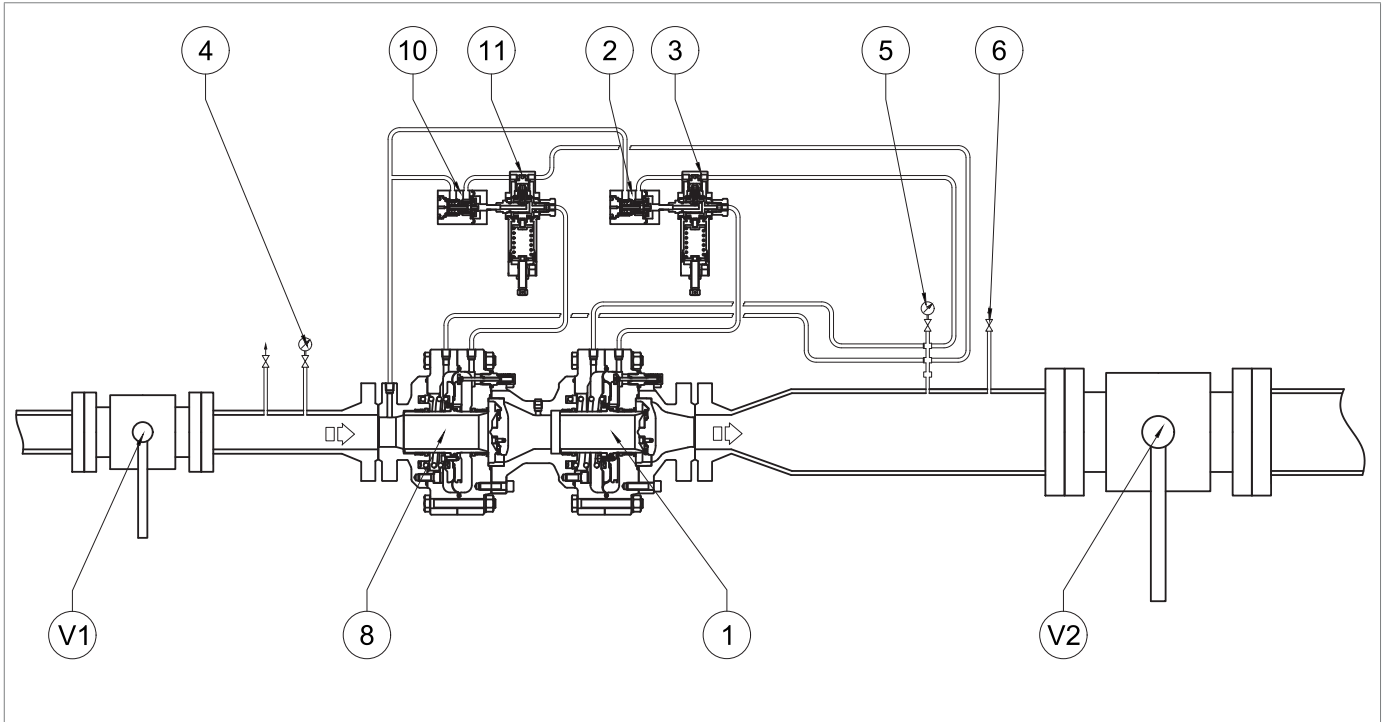







Fig. 8.25. Procedure for commissioning the ASX 176 regulator with the PM/176 built-in monitor

Step	Action
1	Partially open the bleed cock (6).
2	Completely unscrew the fixing nut and the adjustment screw (Fig. 8.30) of the pilots (3, 11) to relieve the spring.
3	Completely compress the pilot spring (3) by turning the adjusting screw (Fig. 8.30) clockwise.
4	Completely relieve the pilot spring (11) by turning the adjusting screw (Fig. 8.30) anticlockwise.
5	Open the upstream shut-off valve (V1) very slowly. <div style="border: 1px solid black; padding: 5px;">  NOTICE! Check the pressure by referring to the pressure gauge (4) located upstream. </div>
6	Turn the adjustment screw (Fig. 8.30) on the monitor pilot (11) clockwise to increase the downstream pressure value to the selected monitor operating value. <div style="border: 1px solid black; padding: 5px;">  NOTICE! Check the pressure referring to the pressure gauge (5) located upstream. </div>
7	Turn the adjusting screw (Fig. 8.30) on the pilot (3) anti-clockwise to relieve the calibration spring until the pre-set downstream pressure value has been reached.
8	Make sure that the PM/176 monitor (8) is fully open (100%) by checking the position of the stroke indicator rod (Fig. 4.5). <div style="border: 1px solid black; padding: 5px;">  NOTICE! Check the pressure referring to the pressure gauge (5) located upstream. </div>
9	Slowly close the bleed cock (6).
10	Check that the downstream pressure, after an increase phase, does not exceed the shut-off pressure value (refer to the SG value on the nameplate, see paragraph 2.8). <div style="border: 1px solid black; padding: 5px;">  NOTICE! <ul style="list-style-type: none"> • If the downstream pressure exceeds the closing pressure value, refer to chapter “10 - Troubleshooting” to clear the causes of the malfunctions; • Check the pressure referring to the pressure gauge (5) located upstream. </div>
11	Check all joints between the shut-off valves (V1, V2) for sealing. <div style="border: 1px solid black; padding: 5px;">  NOTICE! Check for sealing with a foaming substance. </div>
12	Open the downstream shut-off valve (V2) very slowly until the pipeline fills completely. <div style="border: 1px solid black; padding: 5px;">  NOTICE! <ul style="list-style-type: none"> • If at the beginning of this operation, the pressure in the downstream pipeline is much lower than the calibration pressure, split the opening of this valve so as not to exceed the maximum flow rate of the system. • Check the pressure referring to the pressure gauge (5) located upstream. </div>
13	Insert and secure the adjusting screws with the fixing nuts (Fig. 8.30) of the pilots (3, 11).

Tab. 8.53.

8.7 - COMMISSIONING PROCEDURE FOR THE ASX 176 REGULATOR WITH BUILT-IN PM/176 MONITOR AND M/A ACCELERATING VALVE

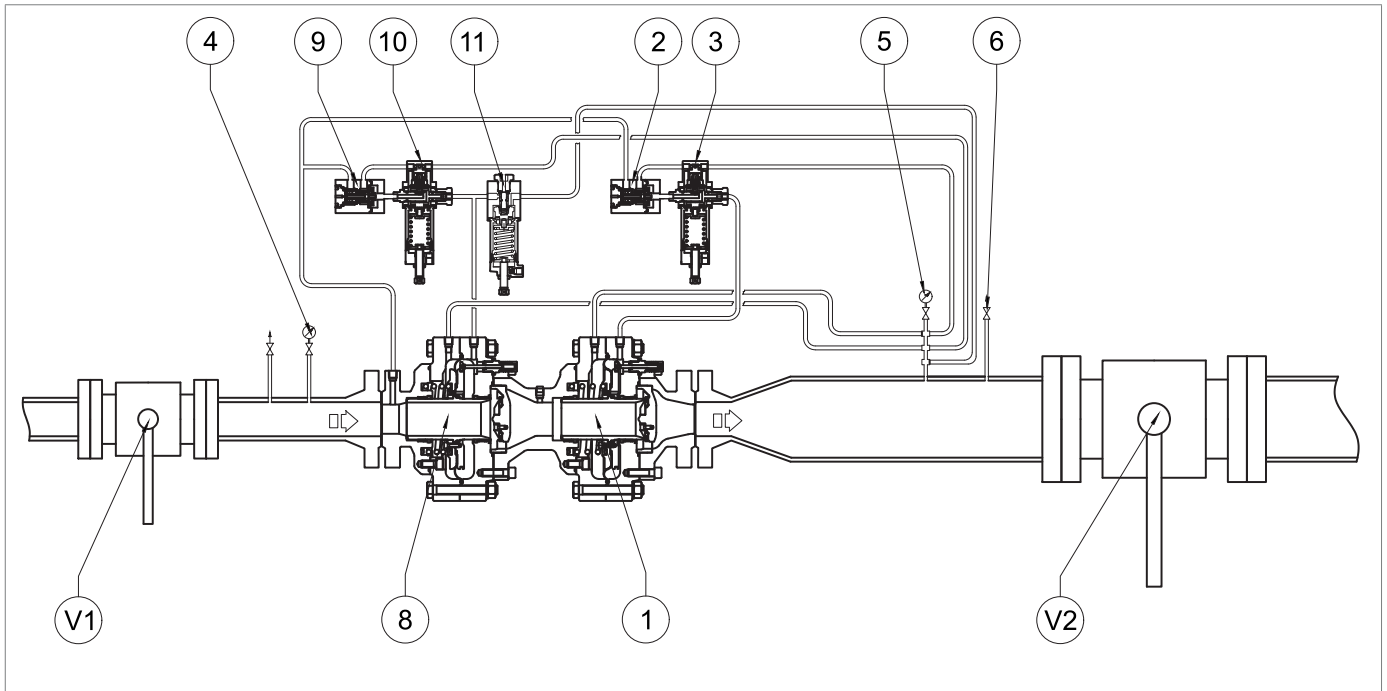

Fig. 8.26. Commissioning of the ASX 176 regulator with built-in PM/176 monitor and M/A accelerating valve

Step	Action
1	Partially open the bleed cock (6).
2	Completely unscrew the fixing nut and the adjusting screw of the pilots (3, 10) and the M/A accelerating valve (11).
3	Completely compress the pilot spring (3) by turning the adjusting screw (Fig. 8.30) clockwise.
4	Completely relieve the pilot spring (10) by turning the adjusting screw (Fig. 8.30) anti-clockwise.
5	Fully compress the M/A accelerating valve spring (11) by turning the adjusting screw clockwise.
6	Open the upstream shut-off valve (V1) very slowly. NOTICE! Check the pressure by referring to the pressure gauge (4) located upstream.
7	Slowly increase the downstream pressure by turning the adjusting screw (Fig. 8.30) of the monitor pilot (10) clockwise until the setpoint pressure of the M/A throttle valve (11) is reached. NOTICE! Check the pressure referring to the pressure gauge (5) located upstream.
8	Turn the adjusting screw of the M/A accelerating valve (11) anti-clockwise to decrease the calibration of the cut-in pressure value until gas is released from the gas outlet. NOTICE! Check the gas outlet with a foaming substance.

Step	Action
9	<p>Turn the adjusting screw (Fig. 8.30) on the monitor pilot (10) anti-clockwise to decrease the downstream pressure value to the selected monitor operating value.</p> <div style="border: 1px solid black; padding: 5px;"> <p>! NOTICE!</p> <ul style="list-style-type: none"> • Ensuring that the M/A accelerating valve (11) has interrupted the gas discharge; • Check the pressure referring to the pressure gauge (5) located upstream. </div>
10	<p>Turn the adjusting screw (Fig. 8.30) on the pilot (3) anti-clockwise to relieve the calibration spring until the pre-set downstream pressure value has been reached.</p> <div style="border: 1px solid black; padding: 5px;"> <p>! NOTICE!</p> <p>Check the pressure referring to the pressure gauge (5) located upstream.</p> </div>
11	<p>Make sure that the PM/176 monitor (8) is fully open (100%) by checking the position of the stroke indicator rod (Fig. 4.5).</p>
12	<p>Slowly close the bleed cock (6).</p>
13	<p>Check that the downstream pressure, after an increase phase, does not exceed the shut-off pressure value (refer to the SG value on the nameplate, see paragraph 2.8).</p> <div style="border: 1px solid black; padding: 5px;"> <p>! NOTICE!</p> <ul style="list-style-type: none"> • If the downstream pressure exceeds the closing pressure value, refer to chapter “10 - Troubleshooting” to clear the causes of the malfunctions. • Check the pressure referring to the pressure gauge (5) located upstream. </div>
14	<p>Check all joints between the shut-off valves (V1, V2) for sealing.</p> <div style="border: 1px solid black; padding: 5px;"> <p>! NOTICE!</p> <p>Check for sealing with a foaming substance.</p> </div>
15	<p>Open the downstream shut-off valve (V2) very slowly until the pipeline fills completely.</p> <div style="border: 1px solid black; padding: 5px;"> <p>! NOTICE!</p> <ul style="list-style-type: none"> • If at the beginning of this operation, the pressure in the downstream pipeline is much lower than the calibration pressure, split the opening of this valve so as not to exceed the maximum flow rate of the system. • Check the pressure referring to the pressure gauge (5) located upstream. </div>
16	<p>Insert and secure the adjusting screws (Fig. 8.30) with the fixing nuts of the pilots (3, 10) and the M/A throttle valve (11).</p>

Tab. 8.54.

8.8 - COMMISSIONING PROCEDURE FOR THE ASX 176 REGULATOR WITH BUILT-IN SSX/176 SLAM-SHUT VALVE

8.8.1 - CHECKING THE SSX/176 SLAM-SHUT VALVE FOR PROPER SEALING DURING SHUT-OFF

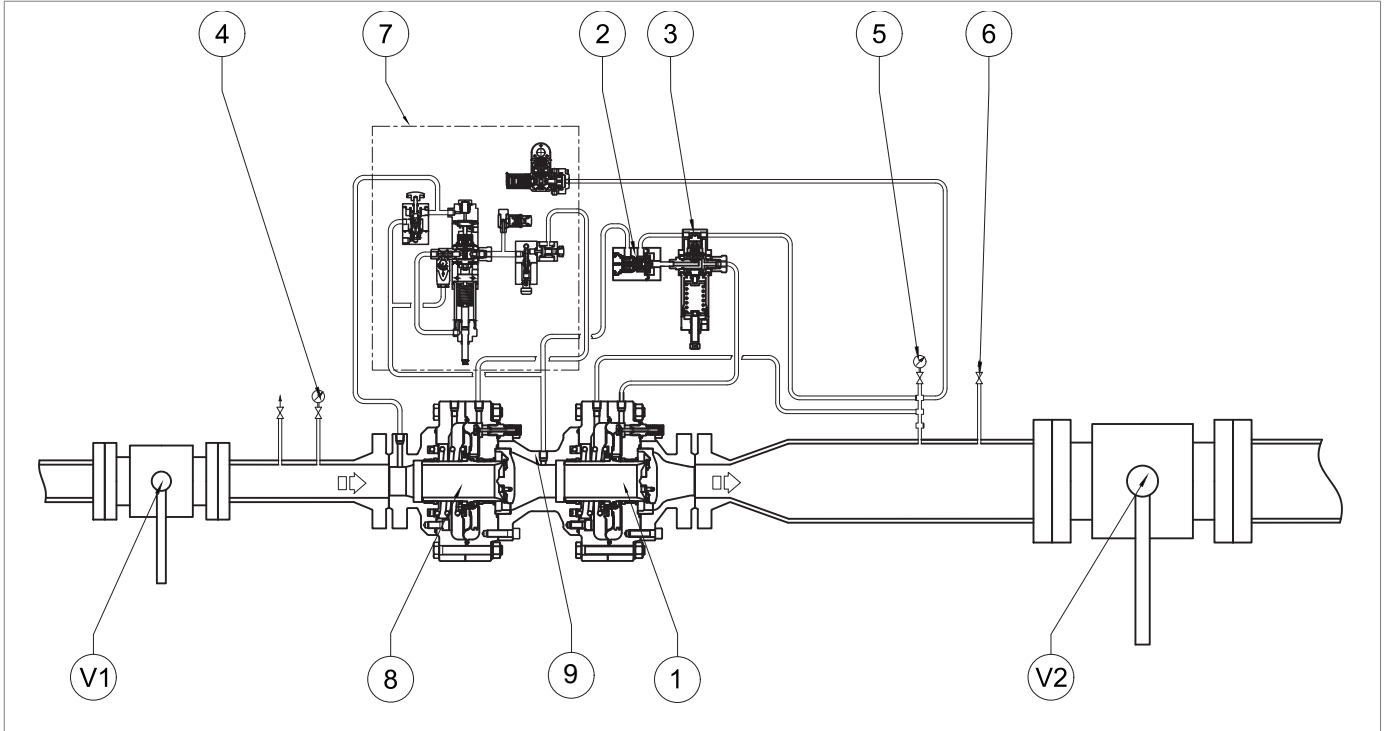

Fig. 8.27. SSX/176 slam-shut valve sealing during sealing

Step	Action
1	Check that the built-in slam-shut valve (8) is in the shut-off position (0%) by checking the position of the stroke indicator rod.
2	Completely unscrew the fixing nut (Fig. 8.30) of the pilot screw (3).
3	Completely relieve the pilot spring (3) by turning the adjusting screw (Fig. 8.30) anti-clockwise.
4	Open the vent (6) and drain the downstream section completely.
5	Disconnect the piping between the R14/A pre-regulator (2) and the intermediate mouthpiece (9).
6	<p>Check the tightness of the built-in slam-shut valve with a foaming substance, through the connection connected to the intermediate mouthpiece (9) of the regulator (1).</p> <div style="border: 1px solid blue; padding: 5px;"> <p>! NOTICE! In case of connection leakage, see chapter "10 - Troubleshooting".</p> </div>
7	<p>Reconnect the piping between the R14/A pre-regulator (2) and the intermediate mouthpiece (9).</p> <div style="border: 1px solid blue; padding: 5px;"> <p>! NOTICE! Check the need to replace the fitting, referring to the fitting manufacturer's instructions.</p> </div>

Tab. 8.55.

8.8.2 - LINE OFF 2.0 COMMISSIONING AND CALIBRATION PROCEDURE FOR SSX/176 BUILT-IN SLAM-SHUT VALVE

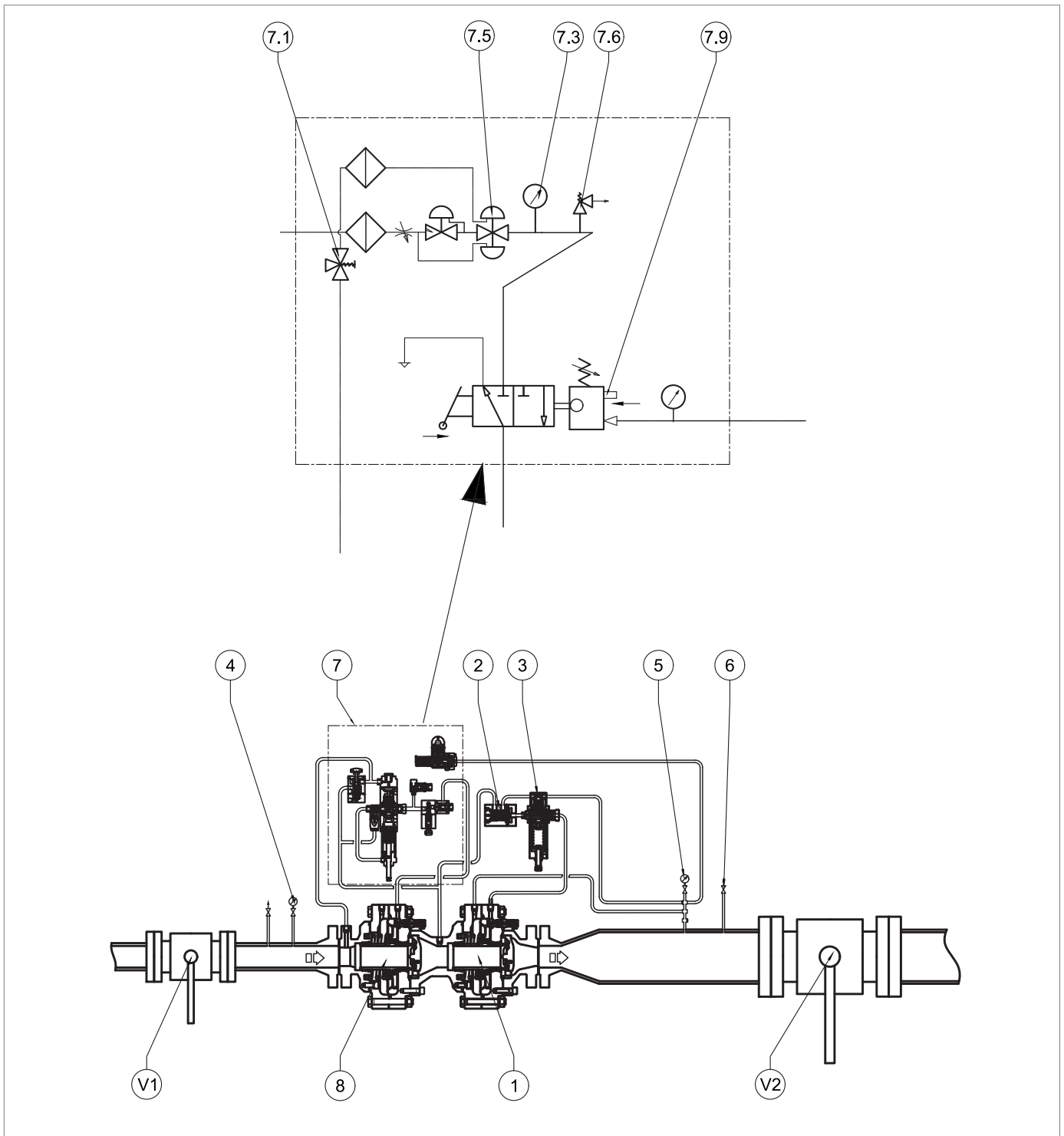



Fig. 8.28. LINE OFF 2.0 commissioning and calibration for the SSX/176 built-in slam-shut valve

Step	Action
1	Press and hold the button of the bypass valve HP2/2 (7.1) to: <ul style="list-style-type: none"> bring the upstream pressure to the power supply unit of the LINE-OFF 2.0 device; balance the pressure of the HBC 975 slam-shut valve plug.
2	Release the button of bypass valve HP2/2 (7.1) after checking that the upstream and downstream pressure of the slam-shut valve is balanced.
3	Turn the adjusting screw of the R44/SS regulator (7.5) clockwise and tighten it until reaching the tripping value (6 bar) of the safety valve VS/FI (7.6). <div style="border: 1px solid blue; padding: 5px; margin-top: 10px;">  NOTICE! Check the pressure, referring to the pressure gauge (7.3) connected to the R44/SS regulator. </div>
4	If the safety valve VS/FI (7.6): <ul style="list-style-type: none"> opens before the expected pressure value, unscrew the shaft collar nut and tighten (clockwise) the adjustment plug so that the spring inside it is further compressed; does not open at the expected pressure value, unscrew the shaft collar nut and loosen the adjustment plug anti-clockwise, so as to release the spring inside.
5	Check the VS/FI valve (7.6) for correct calibration: <ul style="list-style-type: none"> decreasing the pressure by adjusting the adjusting screw of the R44/SS regulator (7.5); increasing the pressure until the VS/FI valve (7.6) trips by turning the adjusting screw of the R44/SS regulator (7.5).
6	Repeat step 5 at least three times to properly calibrate the VS/FI safety valve (7.6).
7	By turning the adjusting screw, calibrate the R44/SS regulator (7.5) to the required pressure value (min. 4 bar, max. 5 bar) referring to the connected pressure gauge (7.3), then: <ul style="list-style-type: none"> if the pressure value on the pressure gauge is lower than the set value of the R44/SS regulator (7.5): tighten the adjusting screw clockwise so as to further compress the spring inside it; if the pressure value on the pressure gauge is higher than the calibration value of the R44/SS regulator (7.5): unscrew the adjusting screw anti-clockwise so as to further release the spring inside.
8	Press the button of bypass valve HP2/2 (7.1) and check that the upstream and downstream pressure is balanced.
9	Release the HP2/2 bypass valve button (7.1).
10	Reset the SSX/176 slam-shut valve by adjusting the lever (7.9).

Tab. 8.56.

COMMISSIONING THE REGULATOR

 **NOTICE!**

Please refer to “8.5 - Regulator commissioning procedure” of this chapter.

8.8.3 - PRESSURE SWITCH CALIBRATION PROCEDURE FOR LINE OFF 2.0 MOD. 100

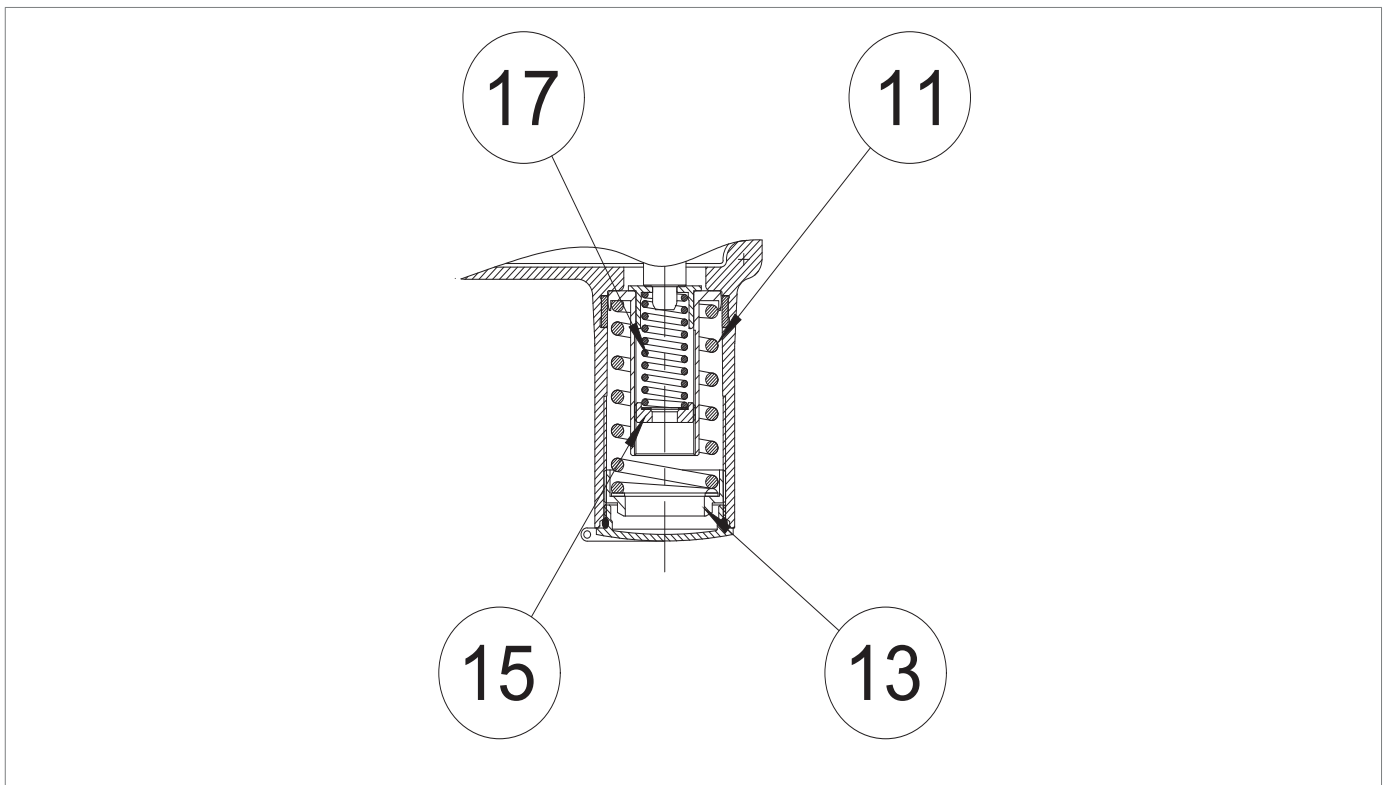

Fig. 8.29. Calibration of pressure switches mod. 100

SPRING SETTING FOR MAXIMUM PRESSURE TRIPPING

Step	Action
1	<p>By adjusting the main regulator, increase the downstream pressure up to the tripping value of the slam-shut valve, to check for proper calibration.</p> <p>! NOTICE!</p> <p>Check the pressure referring to the pressure gauge (Fig. 8.24, ref.5) downstream of the main regulator. If the slam-shut valve:</p> <ul style="list-style-type: none"> trips before the expected pressure value: screw in (clockwise) the adjustment ring nut (13) so as to further compress the spring (11); does not trip at the expected pressure value: unscrew (anti-clockwise) the adjustment ring nut (13) so as to relieve the spring (11).
2	By opening the vent (Fig. 8.24, ref.6), decrease the pressure in the downstream section to the calibration value of the main regulator.
3	Close the vent (Fig. 8.24, ref. 6).
4	Reset the slam-shut device by adjusting the lever in the 3/2 valve (Fig. 4.1, ref. 8).
5	<p>Repeat steps 2-3-4 at least three times.</p> <p>! NOTICE!</p> <p>The calibration value must comply with the operating limits specified on the plate.</p>

Tab. 8.57.

SPRING CALIBRATION FOR MINIMUM PRESSURE TRIP (IF ANY)

Step	Action
1	Open the vent (Fig. 8.24, ref. 6) to the atmosphere and keep it open for the subsequent phases.
2	<p>Decrease the downstream pressure to the minimum tripping pressure of the slam-shut device by adjusting the pilot.</p> <div style="border: 1px solid black; padding: 5px;"> <p>! NOTICE!</p> <p>Check the pressure referring to the downstream pressure gauge (Fig. 8.24, ref. 5).</p> <p>If the slam-shut valve:</p> <ul style="list-style-type: none"> • trips before the expected pressure value: unscrew (anti-clockwise) the adjustment ring nut (15) so as to relieve the spring (17); • does not trip before the expected pressure value, screw in (clockwise) the adjustment ring nut (15) so as to further compress the spring (17). </div>
3	Close the vent (Fig. 8.24, ref. 6).
4	Equalize the upstream and downstream pressure of the slam shut valve using the HP2/2 by-pass valve (Fig. 8.28, ref. 7.1).
5	Re-open the vent (Fig. 8.24, ref. 6).
6	Increase the downstream pressure up to the calibration value by adjusting the main regulator.
7	Reset the slam-shut device by adjusting the lever in the 3/2 valve (Fig. 4.1, ref. 8).
8	<p>Check the main regulator for proper calibration.</p> <div style="border: 1px solid black; padding: 5px;"> <p>! NOTICE!</p> <p>The calibration value must comply with the operating limits specified on the plate.</p> </div>
9	Check the minimum pressure spring for proper calibration by repeating steps 2-3-4 at least three times.
10	Close the vent (Fig. 8.24, ref. 6).
11	Check the maximum pressure spring for proper calibration by repeating steps 2-3-4 of Tab. 8.57 at least three times.

Tab. 8.58.

COMMISSIONING THE REGULATOR

! NOTICE!

Please refer to “8.5 - Regulator commissioning procedure” of this chapter.

8.9 - DEVICE CALIBRATION

8.9.1 - CALIBRATION OF 200/A SERIES PILOTS

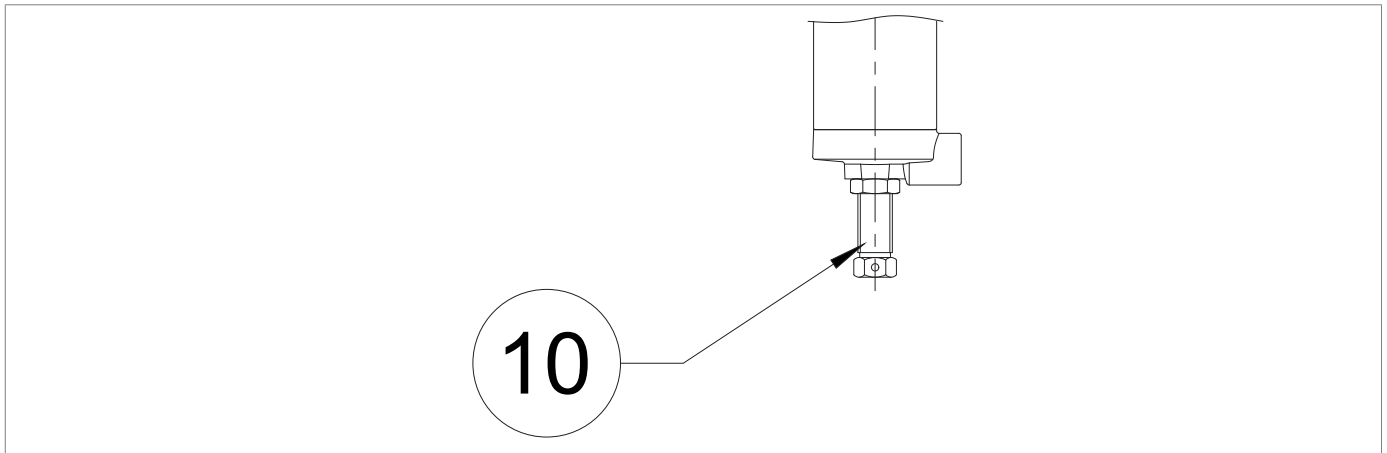

Fig. 8.30. 200/A series pilots

Turn the adjusting screw (10):

- anticlockwise to decrease the adjusted pressure;
- clockwise to increase the adjusted pressure.

8.9.2 - CALIBRATION OF PRESSURE SWITCHES MOD. 100

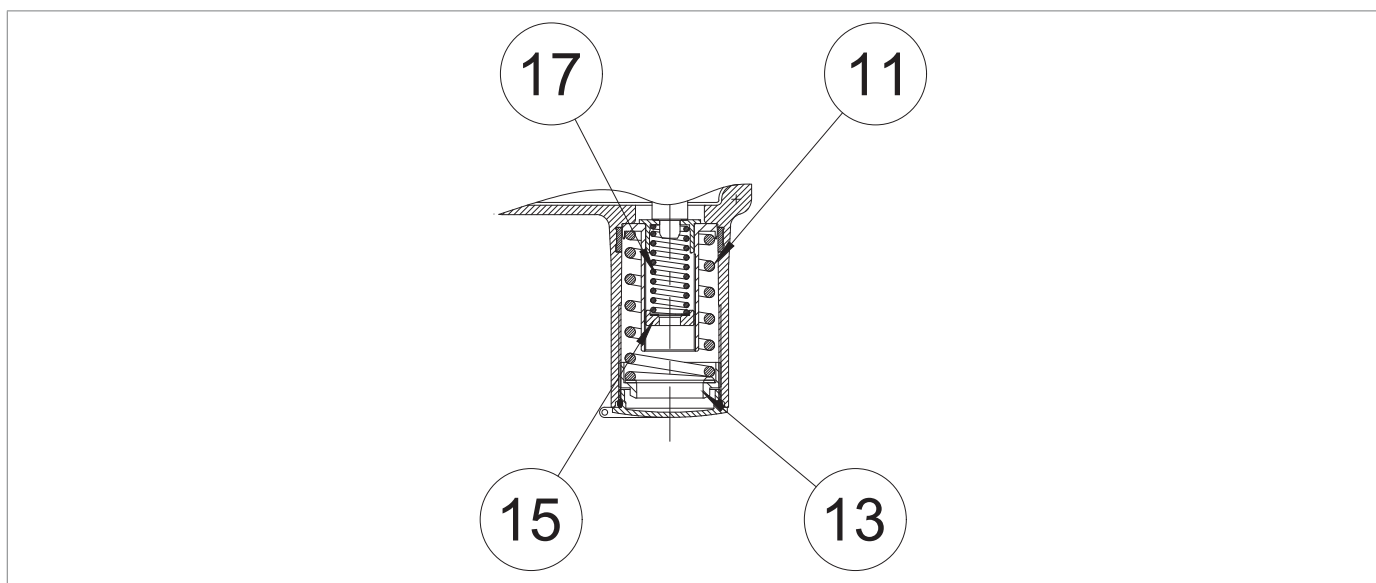

Fig. 8.31. Pressure switches mod. 100

Adjust the maximum pressure (11) ring nut (13):

- anti-clockwise to decrease the slam-shut device tripping pressure;
- clockwise to increase the slam-shut device tripping pressure.

Turn the minimum pressure (17) ring nut (15):

- anti-clockwise to decrease the slam-shut device tripping pressure;
- clockwise to increase the slam-shut device tripping pressure.

 **NOTICE!**

For calibration ranges, please refer to chapter “13 - Calibration tables”.

PAGE INTENTIONALLY LEFT BLANK

9 - MAINTENANCE AND FUNCTIONAL CHECKS

9.1 - GENERAL WARNINGS

HAZARD!

- Maintenance work must be carried out by qualified personnel trained on safety in the workplace and authorised to carry out equipment-related activities.
- Each maintenance operation requires in-depth and specialised knowledge of the equipment, the necessary operations, the associated risks and the correct procedures to operate safely.
- Repair or maintenance work not provided for in this manual may be carried out only if approved by PIETRO FIORENTINI S.p.A.. No liability for personal injury or damage to property can be attributed to PIETRO FIORENTINI S.p.A. for work other than that described or performed in a manner other than indicated.

WARNING!

Before any intervention, it is necessary:

- to ensure that the line on which the equipment is installed is shut off upstream and downstream;
 - to operate the slam shut valve in manual mode by pressing the release button (Pos. 10 - Figure 4.10.).
- Next, check that the pressure indicated by the pressure gauge installed on the LINE OFF 2.0 device (Pos. 7.3 - Figure 8.28.) is 0 bar, ensuring complete depressurisation of the line.

WARNING!

In case of doubt, do not perform any work. Contact PIETRO FIORENTINI S.p.A. for the necessary clarifications.

The management and/or use of the equipment includes interventions that are necessary as a result of normal use such as:

- inspection and checks;
- functional checks;
- routine maintenance;
- special maintenance.

NOTICE!

Maintenance work is strictly related to:

- the quality of the conveyed gas (impurities, humidity, gasoline, corrosive substances);
- the effectiveness of filtration;
- the conditions of use of the equipment.

To properly run the equipment, one should:

- follow the service frequency referred to in the manual for functional checks and routine maintenance.
- not exceed the time interval between one service and the next. The time interval is to be understood as the maximum acceptable; it can, however, be shortened;
- promptly check the causes of any anomalies such as excessive noise, leakage of fluids or similar and remedy them. The timely removal of any causes of anomaly and/or malfunction prevents further damage to the equipment and ensures operator safety;

Before beginning disassembly of the equipment, make sure that:

- the spare parts and parts used in replacements have adequate requirements to ensure the original performance of the equipment. Use original, compliant spare parts;
- the operator must have the necessary equipment (see chapter "7 - Commissioning/maintenance equipment").

! NOTICE!

The recommended spare parts are unambiguously identified with tags indicating:



- **the assembly drawing number of the equipment in which they are to be used (see chapter "12 - Recommended spare parts");**
- **the position shown in the assembly drawing of the equipment.**

The equipment maintenance operations are divided, from an operational point of view, into three main categories:

Commissioning and maintenance operations	
Periodic checks and inspections	All those checks that the operator must carry out on a regular basis to ensure that the equipment is in proper working order.
Routine maintenance	All those operations that the operator must preventively carry out to ensure proper operation of the device over time. Routine maintenance includes: <ul style="list-style-type: none"> • inspection; • control; • adjustment; • cleaning; • lubrication; • replacement; of all spare parts.
Special maintenance	All those operations to be carried out by the operator when the equipment requires them.

Tab. 9.59.

9.2 - PERIODICALLY CHECKING AND INSPECTING THE EQUIPMENT FOR PROPER OPERATION

Periodic checks and inspections	
Operator qualification	Mechanical maintenance technician
PPE required	 <div style="background-color: orange; padding: 5px; margin-top: 10px;">  WARNING! </div> <p>The PPE listed in this table is related to the risk associated with the equipment. For the required PPE to protect against risks associated with the workplace, installation or operating conditions, please refer to:</p> <ul style="list-style-type: none"> the regulations in force in the country of installation; <u>any information provided by the Safety Manager at the installation facility.</u>

Tab. 9.60.

Tab. 9.61 lists checks and verifications, i.e. operations that do not require any manual intervention on the individual equipment.

Some items thereof can be replaced remotely using suitable remote control tools.

Activity description	Equipment/accessories involved	Evaluation criterion	Minimum frequency
Control of significant performance*	Pressure regulators	<ul style="list-style-type: none"> No fluctuations in the adjusted pressure. Significant pressure values within pre-set limits. 	Monthly
	Gas flow slam-shut type safety devices (external position indicator)	<ul style="list-style-type: none"> Fully open position. 	
	Stand-by monitor (external position indicator)	<ul style="list-style-type: none"> Fully open position. 	
Visual inspection of external status of the equipment	All	<ul style="list-style-type: none"> No visible damage. External surface protection as per UNI 9571-1:2012. 	Half-yearly

Tab. 9.61.

* These checks may be carried out remotely if there is a remote control system capable of analysing the significant performance of the equipment and of sending alerts/alarms when pre-set thresholds are reached.

9.3 - ROUTINE MAINTENANCE

9.3.1 - GENERAL SAFETY WARNINGS

HAZARD!

- Put the equipment in a safe condition (close the downstream shut-off valve and then the upstream one, and drain the line completely);
- Ensure that the pressure upstream and downstream of the equipment is 0.

WARNING!

Before any intervention, it is necessary:

- to ensure that the line on which the equipment is installed is shut off upstream and downstream;
 - to operate the slam shut valve in manual mode by pressing the release button (Pos. 10 - Figure 4.10.).
- Next, check that the pressure indicated by the pressure gauge installed on the LINE OFF 2.0 device (Pos. 7.3 - Figure 8.28.) is 0 bar, ensuring complete depressurisation of the line.

NOTICE!

Before installing new sealing elements (o-rings, diaphragm, etc.), their integrity must be checked.

9.3.2 - REPLACEMENT FREQUENCY FOR COMPONENTS SUBJECT TO WEAR

NOTICE!

The following provisions shall apply to equipment components only.

The non-metallic parts of the equipment concerned are divided into the following two categories:

Preventive maintenance work	
Category 1	Parts subject to wear and/or abrasion, where: <ul style="list-style-type: none"> wear and tear means the normal degradation of a part after prolonged use under normal operating conditions; abrasion is the mechanical action on the surface of the affected part resulting from the passage of gas under normal operating conditions.
Category 2	Parts subject to aging only, including parts that also require lubrication and/or cleaning.

Tab. 9.62.

NOTICE!







Check, within the minimum frequency specified in Tab. 9.63, the available components for wear/abrasion/aging.

Category	Part description	Evaluation criterion	Minimum replacement frequency
1	Valve seat sealing rings and non-metallic plugs	Pressure regulators	6 years
		Safety devices	
		Pressure safety system equipment	
1	Non-metallic parts with internal sealing function of valve seats and accessories of individual equipment	Pilots	6 years
		Pre-regulators	
		Accelerators	
1	Non-metallic parts with a sealing function between parts, at least one of which is in motion under normal working/operating conditions	Any others	6 years
		Pressure regulators	
		Gas flow slam-shut type safety devices	
1	Non-metallic parts with sealing function involved in disassembly operations during maintenance	Relief devices with discharge to atmosphere	6 years
		Equipment subject to maintenance	
2	Non-metallic parts providing feedback (sensing elements) of the controlled pressure of safety equipment.	Safety equipment and/or accessories	6 years
2	Non-metallic parts with sealing and performance functions (diaphragms) of equipment	Pressure regulators and accessories	6 years
		Gas flow slam-shut type safety devices	6 years
		Relief device with discharge to atmosphere	6 years
2	Non-metallic parts of equipment with an internal sealing function: under normal operating conditions during maintenance	Relief valves	6 years
		Regulation lines disconnection equipment	In the presence of ascertained leaks

Category	Part description	Evaluation criterion	Minimum replacement frequency
2	Non-metallic parts with a static sealing function only	Various equipment	In the presence of ascertained leaks
2	Lubricating parts	Shut-off valves	Yearly
		Other equipment	Yearly
2	Filter elements	Filters	As needed

Tab. 9.63.

9.4 - ROUTINE MAINTENANCE PROCEDURES

Routine maintenance	
Operator qualification	Mechanical maintenance technician
PPE required	<div style="display: flex; justify-content: space-around; align-items: center;">      </div> <div style="background-color: #e67e22; color: white; padding: 5px; margin-top: 5px;">  WARNING! </div> <p>The PPE listed in this table is related to the risk associated with the equipment. For the required PPE to protect against risks associated with the workplace, installation or operating conditions, please refer to:</p> <ul style="list-style-type: none"> the regulations in force in the country of installation; <u>any information provided by the Safety Manager at the installation facility.</u>
Equipment required	Please refer to the chapter "7 - Commissioning/maintenance equipment".

Tab. 9.64.

9.4.1 - TIGHTENING TORQUES ASX 176

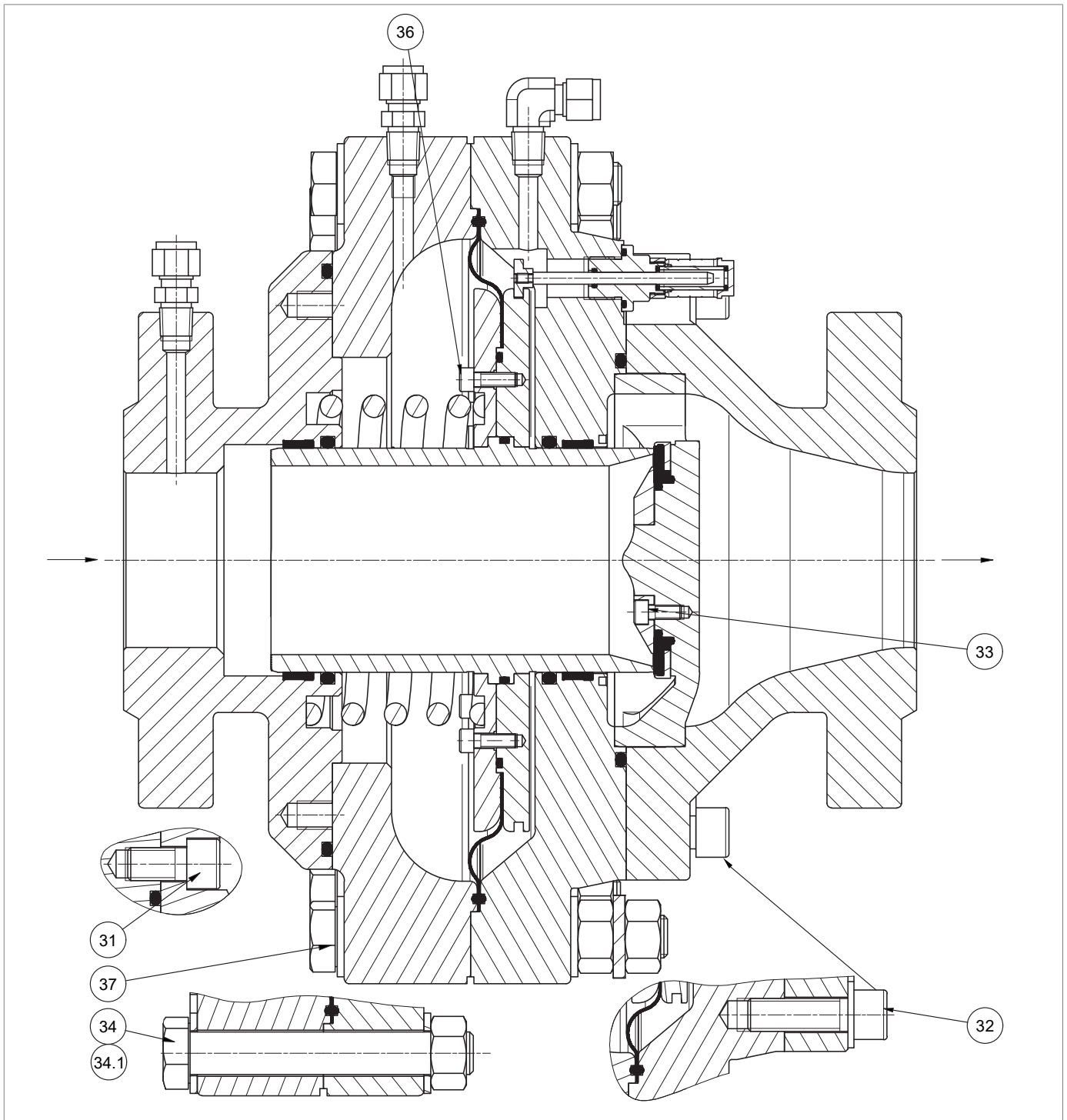

Fig. 9.32. Tightening torques ASX 176

ASX 176 1"

Pos.	Description	Torque (Nm)	Torque (ft - lb)
32	Screw M12X30 UNI 5931	80	59
33	Screw M6X12 UNI 5931	10	7
34	Screw M16X100 UNI 5739	200	147
34.1	Screw M16X100 UNI 5739	200	147
36	Screw M6X10 UNI 5931	10	7
37	Screw M16X110 UNI 5739	200	147

Tab. 9.65.
ASX 176 2"

Pos.	Description	Torque (Nm)	Torque (ft - lb)
31	Screw M12X25 UNI 5931	80	59
32	Screw M12X45 UNI 5931	80	59
33	Screw M6X12 UNI 5931	10	7
34	Screw M16X120 UNI 5739	200	147
34.1	Screw M16X120 UNI 5739	200	147
36	Screw M6X20 UNI 5931	10	7
37	Screw M16X130 UNI 5737	200	147

Tab. 9.66.
ASX 176 3"

Pos.	Description	Torque (Nm)	Torque (ft - lb)
31	Screw M14X25 UNI 5931	130	95
32	Screw M14X45 UNI 5931	130	95
33	Screw M6X14 UNI 5931	10	7
34	Screw M18X120 UNI 5739	200	147
34.1	Screw M18X120 UNI 5739	200	147
36	Screw M6X18 UNI 5931	10	7
37	Screw M18X140 UNI 5737	200	147

Tab. 9.67.
ASX 176 4"

Pos.	Description	Torque (Nm)	Torque (ft - lb)
31	Screw M16X35 UNI 5931	200	147
32	Screw M16X60 UNI 5931	200	147
33	Screw M6X14 UNI 5931	10	7
34	Screw M22X150 UNI 5739	280	206
34.1	Screw M22X150 UNI 5739	280	206
36	Screw M6X16 UNI 5931	10	7

Tab. 9.68.

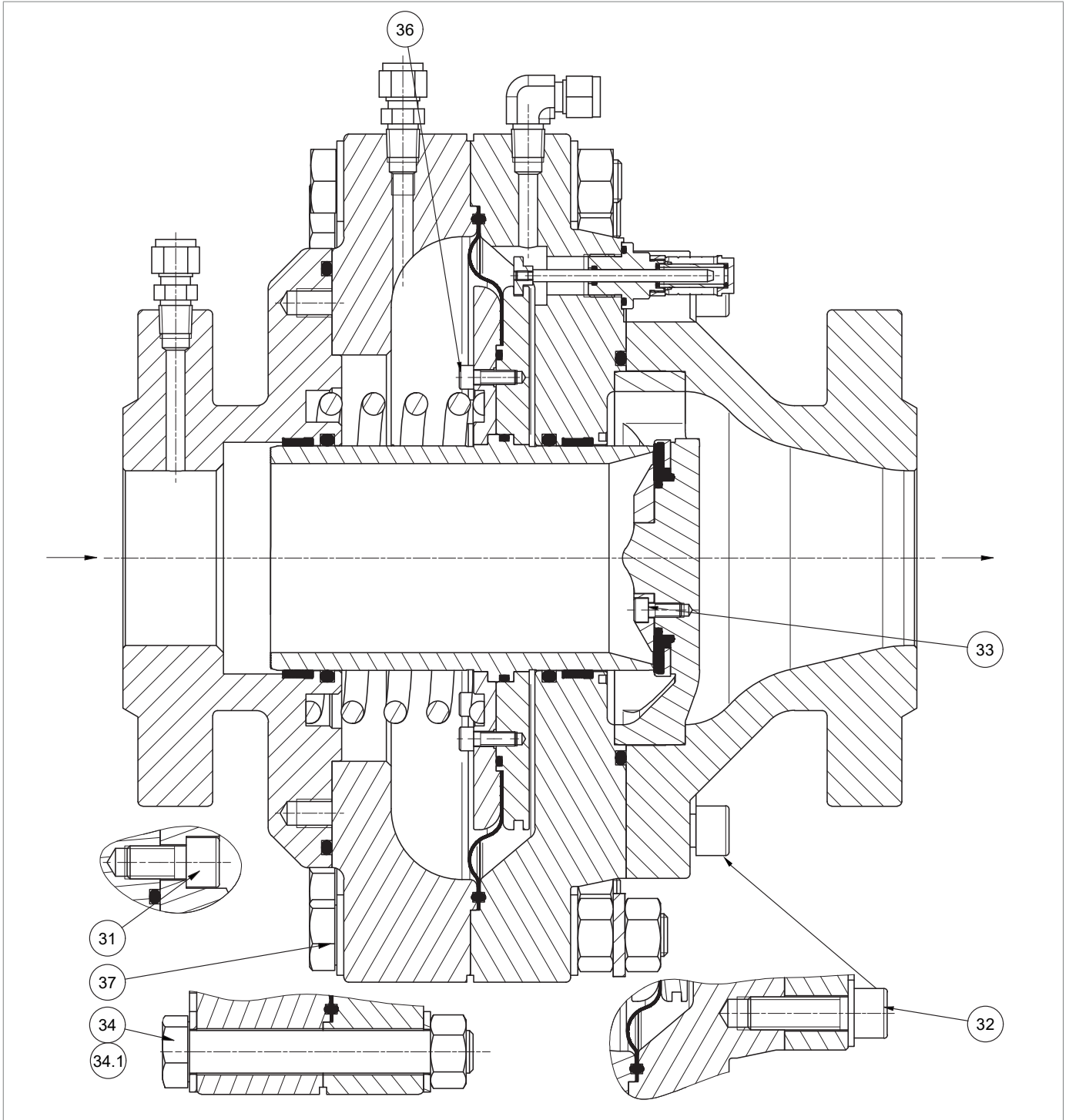

Tightening torques ASX 176

ASX 176 6"

Pos.	Description	Torque (Nm)	Torque (ft - lb)
31	Screw M18X50 UNI 5931	220	162
32	Screw M18X60 UNI 5931	220	162
33	Screw M6X14 UNI 5931	10	7
34	Screw M27X200 UNI 5739	300	221
34.1	Screw M27X200 UNI 5739	300	221
36	Screw M6X16 UNI 5931	10	7
37	Pilot screw ASX 176	300	221

Tab. 9.69.

9.4.1.1 - TIGHTENING TORQUES ASX 176 + SILENCER LDB/176

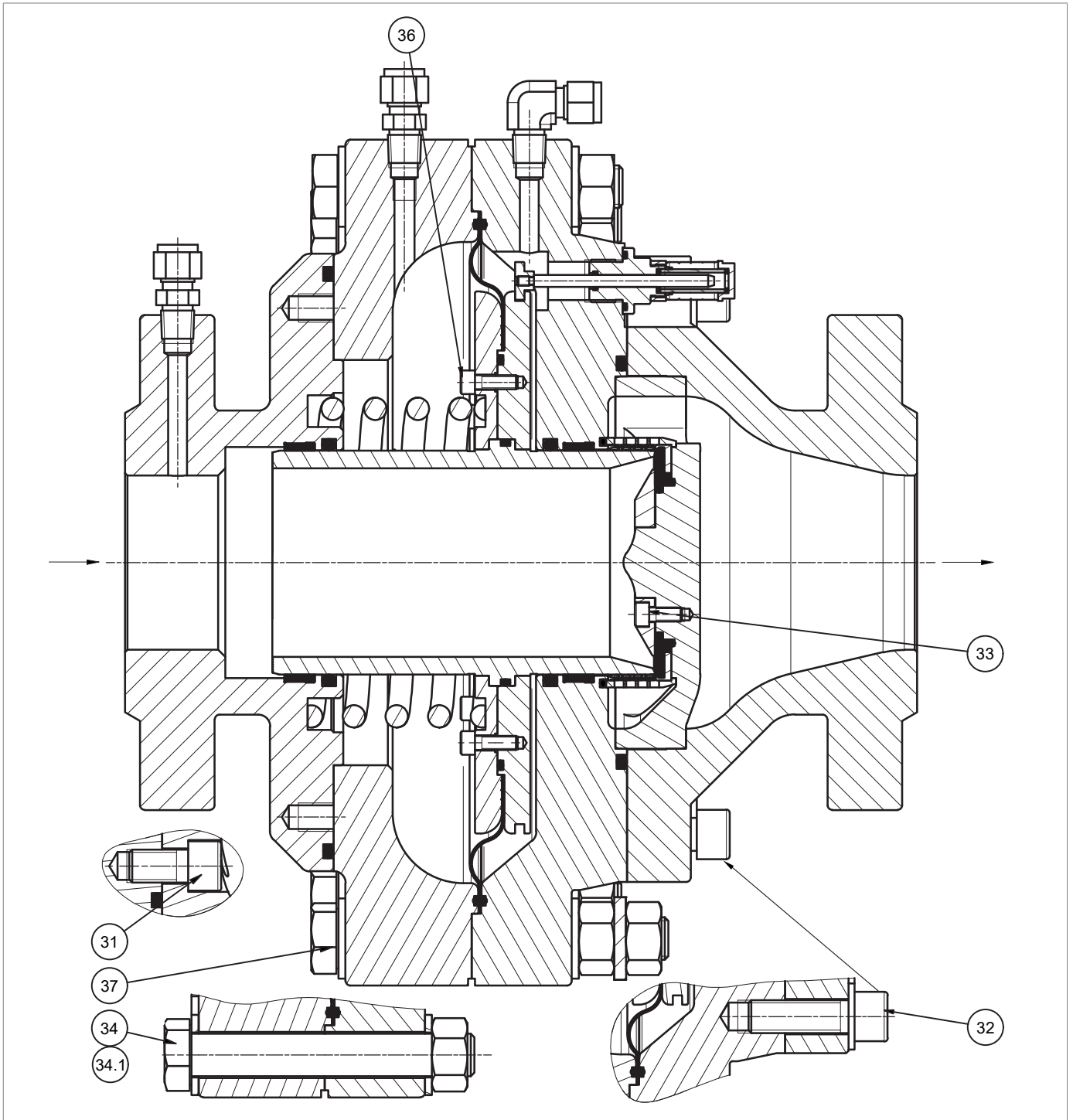

Fig. 9.33. Tightening torques ASX 176 + Silencer LDB/176

ASX 176 1" + LDB/176

Pos.	Description	Torque (Nm)	Torque (ft - lb)
32	Screw M12X30 UNI 5931	80	59
33	Screw M6X12 UNI 5931	10	7
34	Screw M16X100 UNI 5739	200	147
34.1	Screw M16X100 UNI 5739	200	147
36	Screw M6X10 UNI 5931	10	7
37	Screw M16X110 UNI 5739	200	147

Tab. 9.70.
ASX 1761 2" + LDB/176

Pos.	Description	Torque (Nm)	Torque (ft - lb)
31	Screw M12X25 UNI 5931	80	59
32	Screw M12X45 UNI 5931	80	59
33	Screw M6X12 UNI 5931	10	7
34	Screw M16X120 UNI 5739	200	147
34.1	Screw M16X120 UNI 5739	200	147
36	Screw M6X20 UNI 5931	10	7
37	Screw M16X130 UNI 5737	200	147

Tab. 9.71.
ASX 176 3" + LDB/176

Pos.	Description	Torque (Nm)	Torque (ft - lb)
31	Screw M14X25 UNI 5931	130	95
32	Screw M14X45 UNI 5931	130	95
33	Screw M6X14 UNI 5931	10	7
34	Screw M18X120 UNI 5739	200	147
34.1	Screw M18X120 UNI 5739	200	147
36	Screw M6X18 UNI 5931	10	7
37	Screw M18X140 UNI 5737	200	147

Tab. 9.72.
ASX 176 4" + LDB/176

Pos.	Description	Torque (Nm)	Torque (ft - lb)
31	Screw M16X35 UNI 5931	200	147
32	Screw M16X60 UNI 5931	200	147
33	Screw M6X14 UNI 5931	10	7
34	Screw M22X150 UNI 5739	280	206
34.1	Screw M22X150 UNI 5739	280	206
36	Screw M6X16 UNI 5931	10	7

Tab. 9.73.

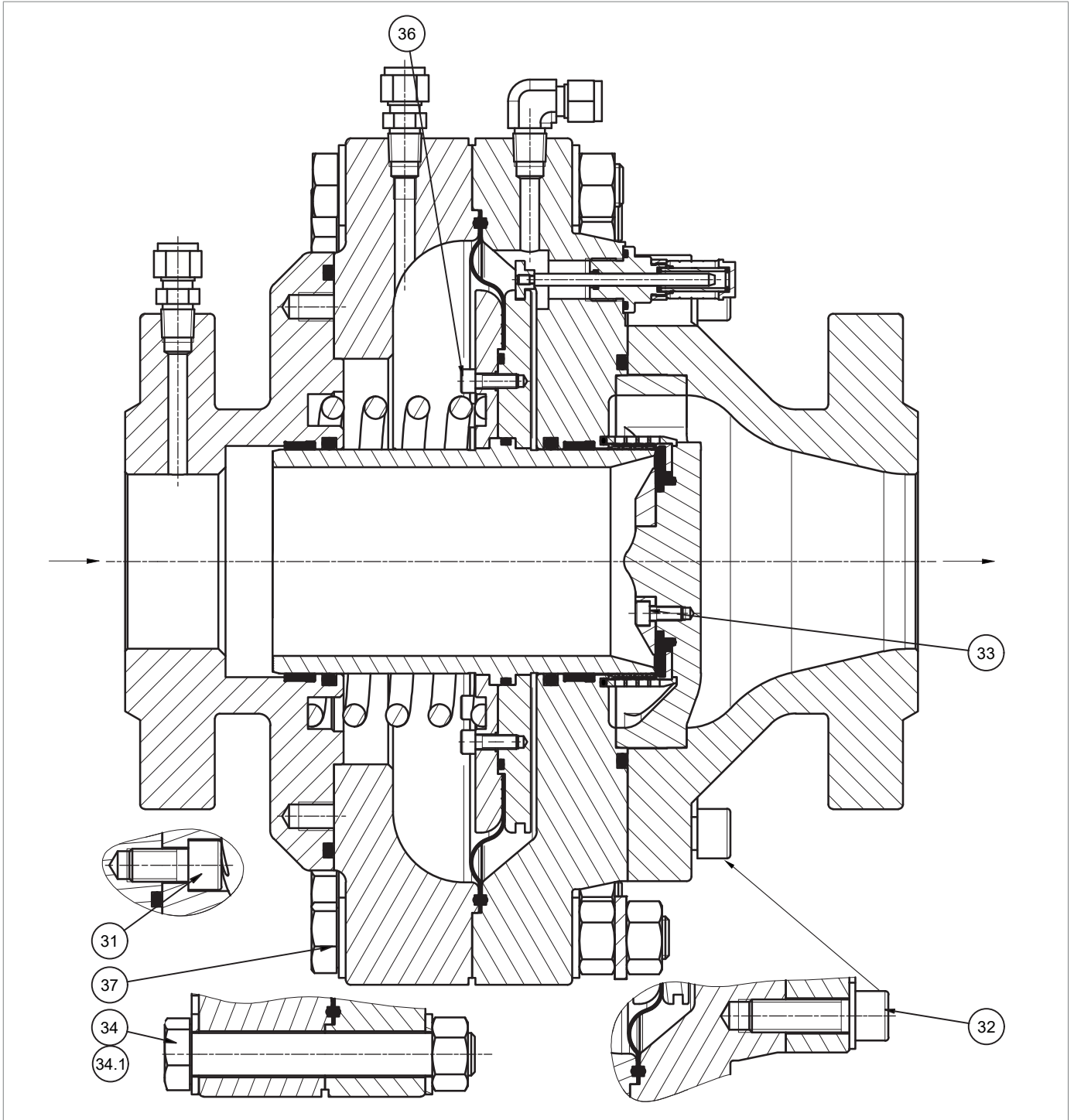

Tightening torques ASX 176 + Silencer LDB/176

ASX 176 6" + LDB/176

Pos.	Description	Torque (Nm)	Torque (ft - lb)
31	Screw M18X50 UNI 5931	220	162
32	Screw M18X60 UNI 5931	220	162
33	Screw M6X14 UNI 5931	10	7
34	Screw M27X200 UNI 5739	300	221
34.1	Screw M27X200 UNI 5739	300	221
36	Screw M6X16 UNI 5931	10	7
37	Pilot screw ASX 176	300	221

Tab. 9.74.

9.4.1.2 - BUILT-IN MONITOR TORQUES PM/176 OR SLAM-SHUT VALVE SSX/176

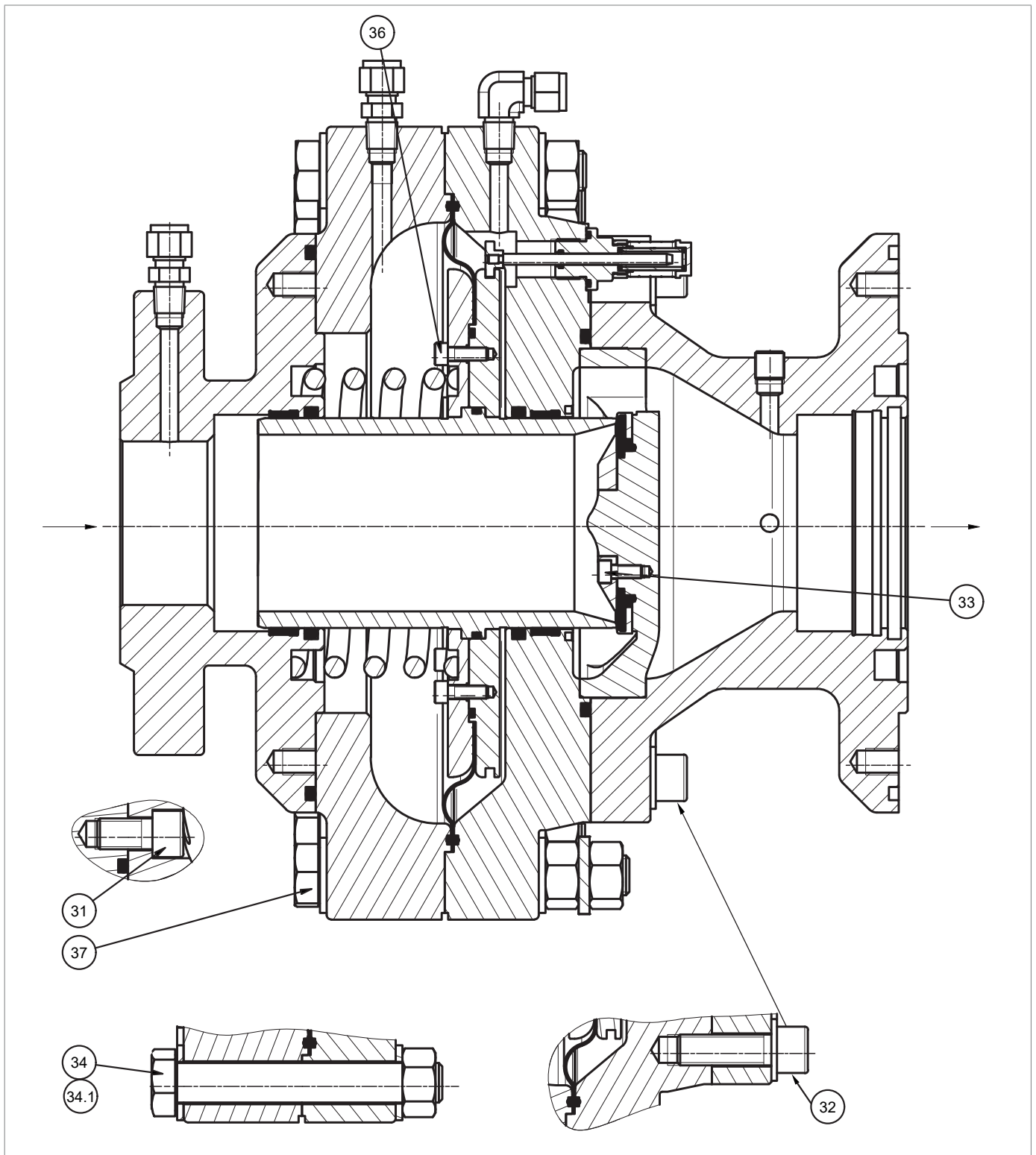

Fig. 9.34. Built-in monitor torque PM/176 or slam-shut valve SSX/176

PM/176 (or SSX/176) DN 1"

Pos.	Description	Torque (Nm)	Torque (ft - lb)
32	Screw M12X30 UNI 5931	80	59
33	Screw M6X12 UNI 5931	10	7
34	Screw M16X100 UNI 5739	200	147
34.1	Screw M16X100 UNI 5739	200	147
36	Screw M6X10 UNI 5931	10	7
37	Screw M16X110 UNI 5739	200	147

Tab. 9.75.
PM/176 (or SSX/176) DN 2"

Pos.	Description	Torque (Nm)	Torque (ft - lb)
31	Screw M12X25 UNI 5931	80	59
32	Screw M12X45 UNI 5931	80	59
33	Screw M6X12 UNI 5931	10	7
34	Screw M16X120 UNI 5739	200	147
34.1	Screw M16X120 UNI 5739	200	147
36	Screw M6X20 UNI 5931	10	7
37	Screw M16X130 UNI 5737	200	147

Tab. 9.76.
PM/176 (or SSX/176) DN 3"

Pos.	Description	Torque (Nm)	Torque (ft - lb)
31	Screw M14X25 UNI 5931	130	95
32	Screw M14X45 UNI 5931	130	95
33	Screw M6X14 UNI 5931	10	7
34	Screw M18X120 UNI 5739	200	147
34.1	Screw M18X120 UNI 5739	200	147
36	Screw M6X18 UNI 5931	10	7
37	Screw M18X140 UNI 5737	200	147

Tab. 9.77.
PM/176 (or SSX/176) DN 4"

Pos.	Description	Torque (Nm)	Torque (ft - lb)
31	Screw M16X35 UNI 5931	200	147
32	Screw M16X60 UNI 5931	200	147
33	Screw M6X14 UNI 5931	10	7
34	Screw M22X150 UNI 5739	280	206
34.1	Screw M22X150 UNI 5739	280	206
36	Screw M6X 16 UNI 5931	10	7

Tab. 9.78.

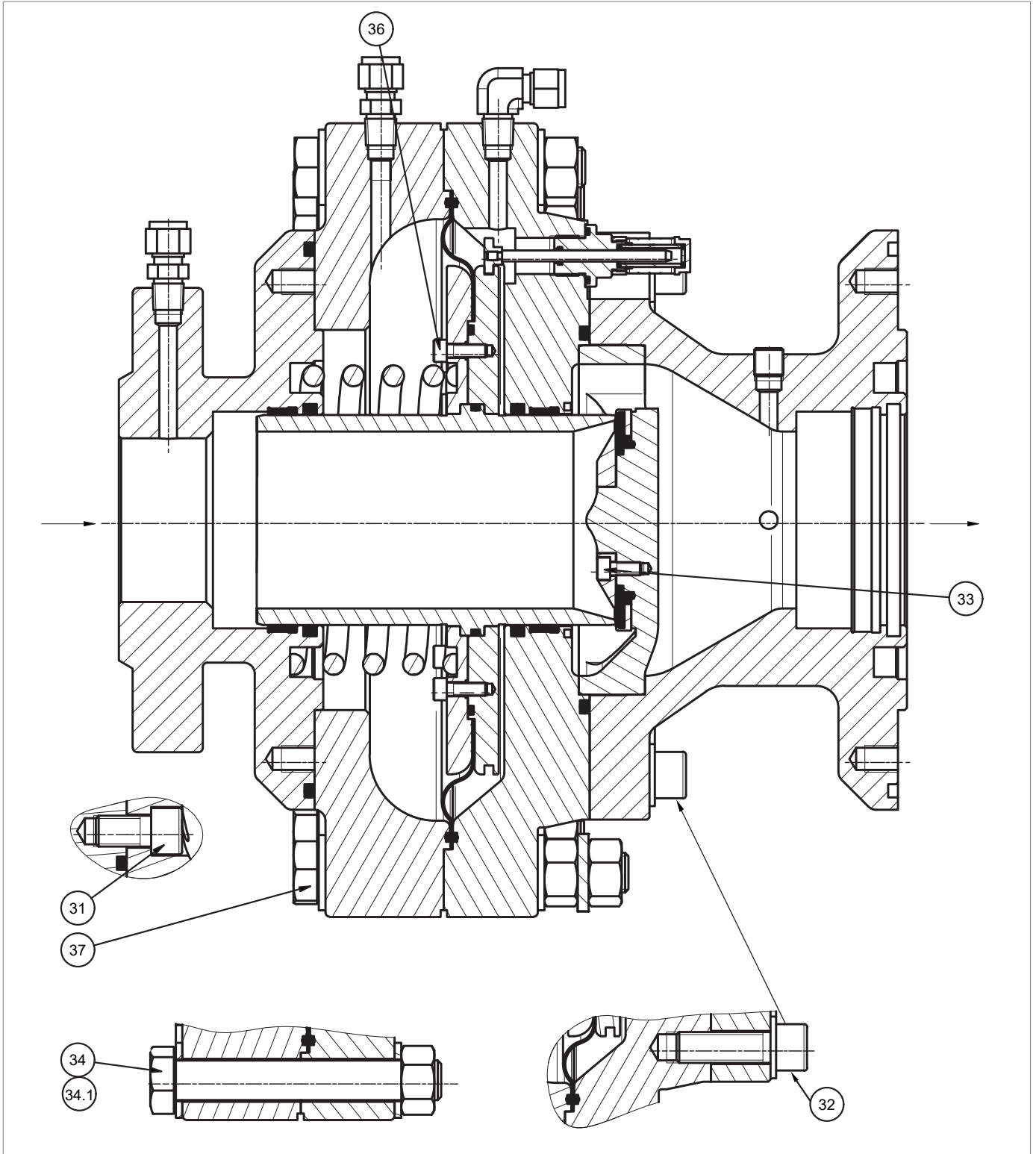

Built-in monitor torque PM/176 or slam-shut valve SSX/176

PM/176 (or SSX/176) DN 6"

Pos.	Description	Torque (Nm)	Torque (ft - lb)
31	Screw M18X50 UNI 5931	220	162
32	Screw M18X60 UNI 5931	220	162
33	Screw M6X14 UNI 5931	10	7
34	Screw M27X200 UNI 5739	300	221
34.1	Screw M27X200 UNI 5739	300	221
36	Screw M6X16 UNI 5931	10	7
37	Pilot screw ASX 176	300	221

Tab. 9.79.

9.4.1.3 - TIGHTENING TORQUES FOR PILOTS SERIES 200

Fig. 9.35. Tightening torques for pilots 204-205-207

PILOTS 204-205

Pos.	Description	Torque (Nm)	Torque (ft - lb)
2	Nut M16X1	25	18
24	Screw M8X30 UNI 5931	20	14
25	Nut M16X1.5	25	18
26	Nut M18X1.5	20	14

Tab. 9.80.

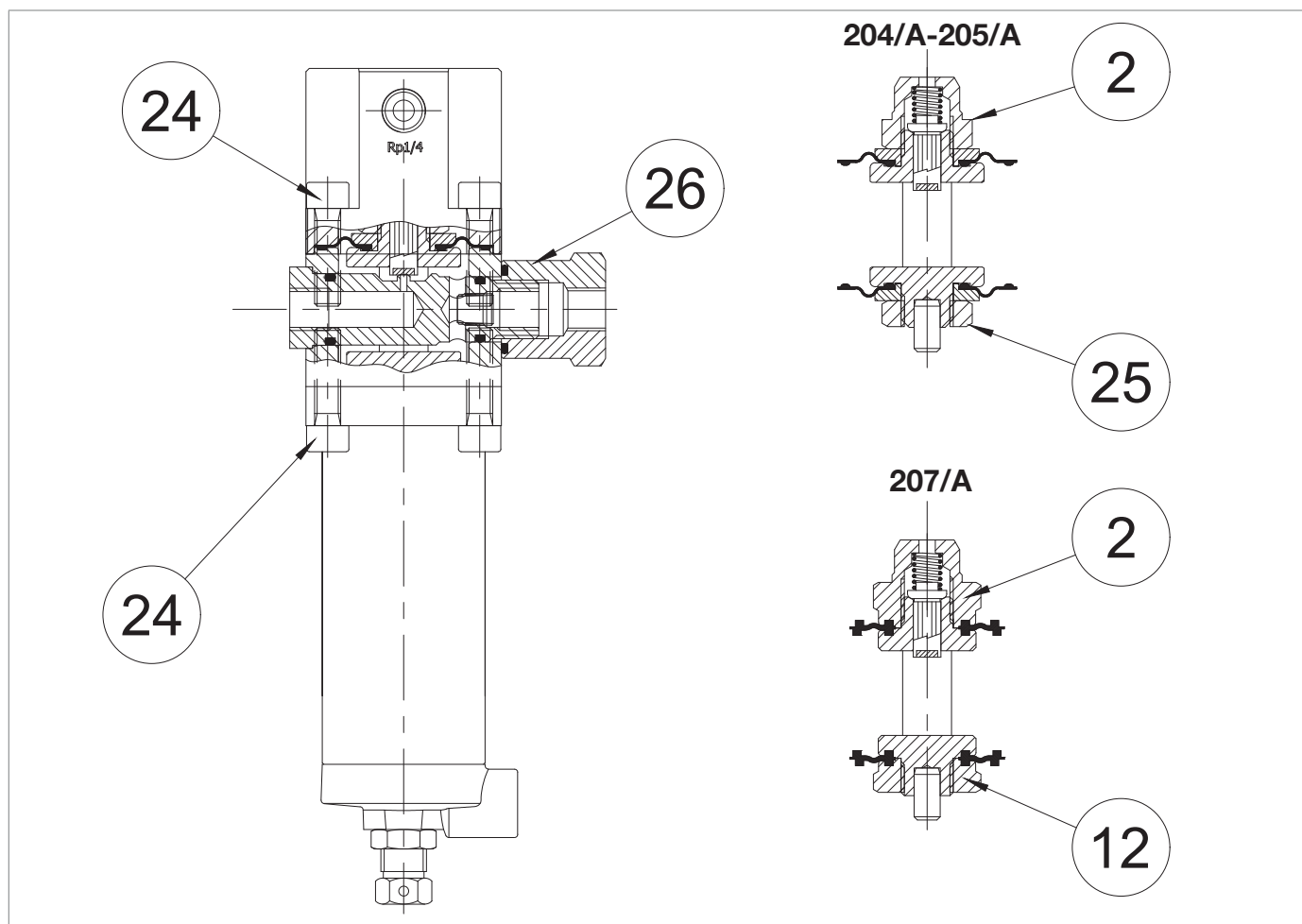
PILOT 207

Pos.	Description	Torque (Nm)	Torque (ft - lb)
2	Nut M16X1	25	18
12	Nut M16X1	25	18
24	Screw M8X30 UNI 5931 AISI	20	14
26	Nut M18X1.5	20	14

Tab. 9.81.

9.4.1.4 - TIGHTENING TORQUES FOR PRE-REGULATORS R14/A

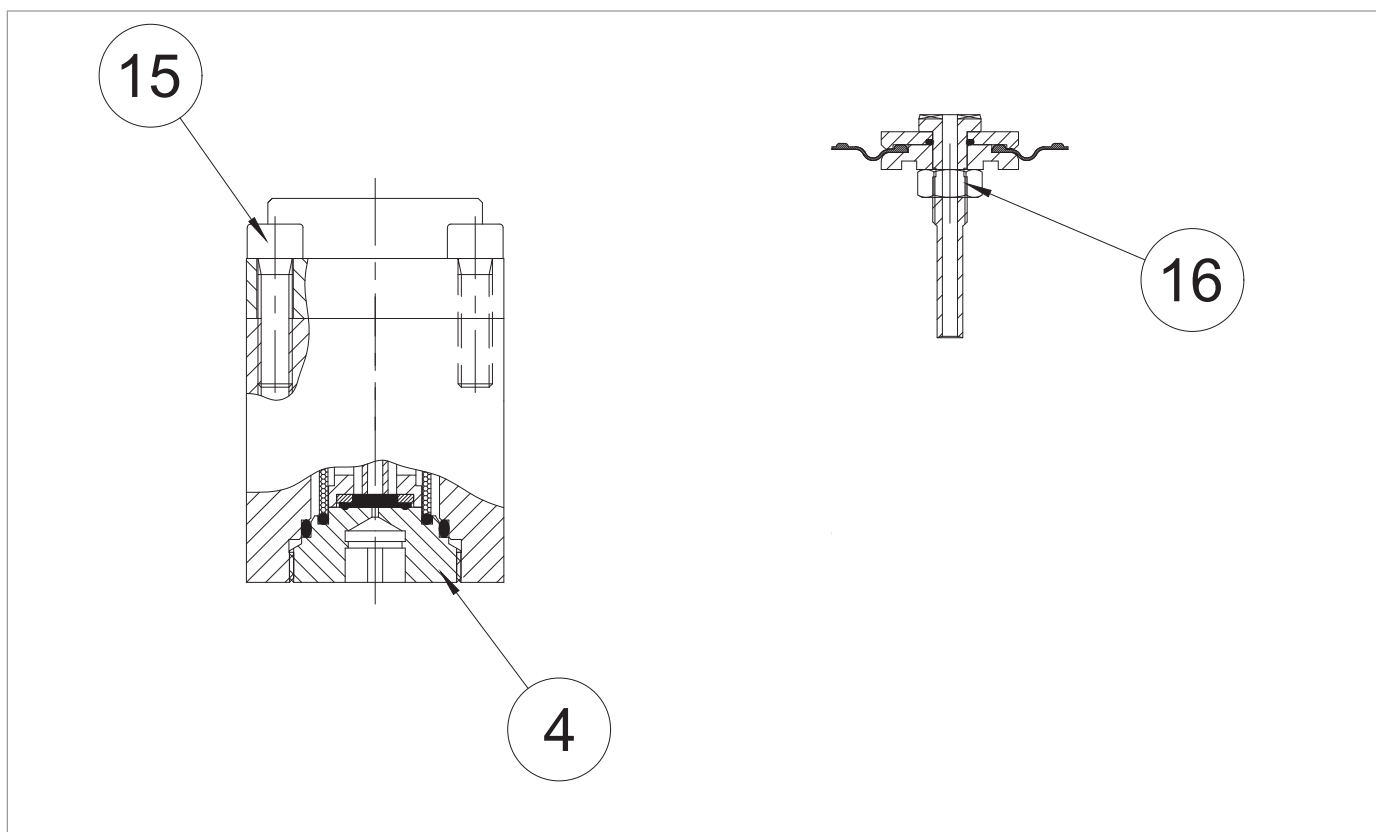

Fig. 9.36. Tightening torques for pre-regulator R14/A

PRE-REGULATOR R14/A			
Pos.	Description	Torque (Nm)	Torque (ft - lb)
4	Cap	35	25
15	Nut M8X30 UNI 5931	20	14
16	Nut M8 UNI 5588	8	5

Tab. 9.82.

9.4.1.5 - TIGHTENING TORQUES FOR PRESSURE SWITCHES MODELS 102M/102MH - 105M/105MH

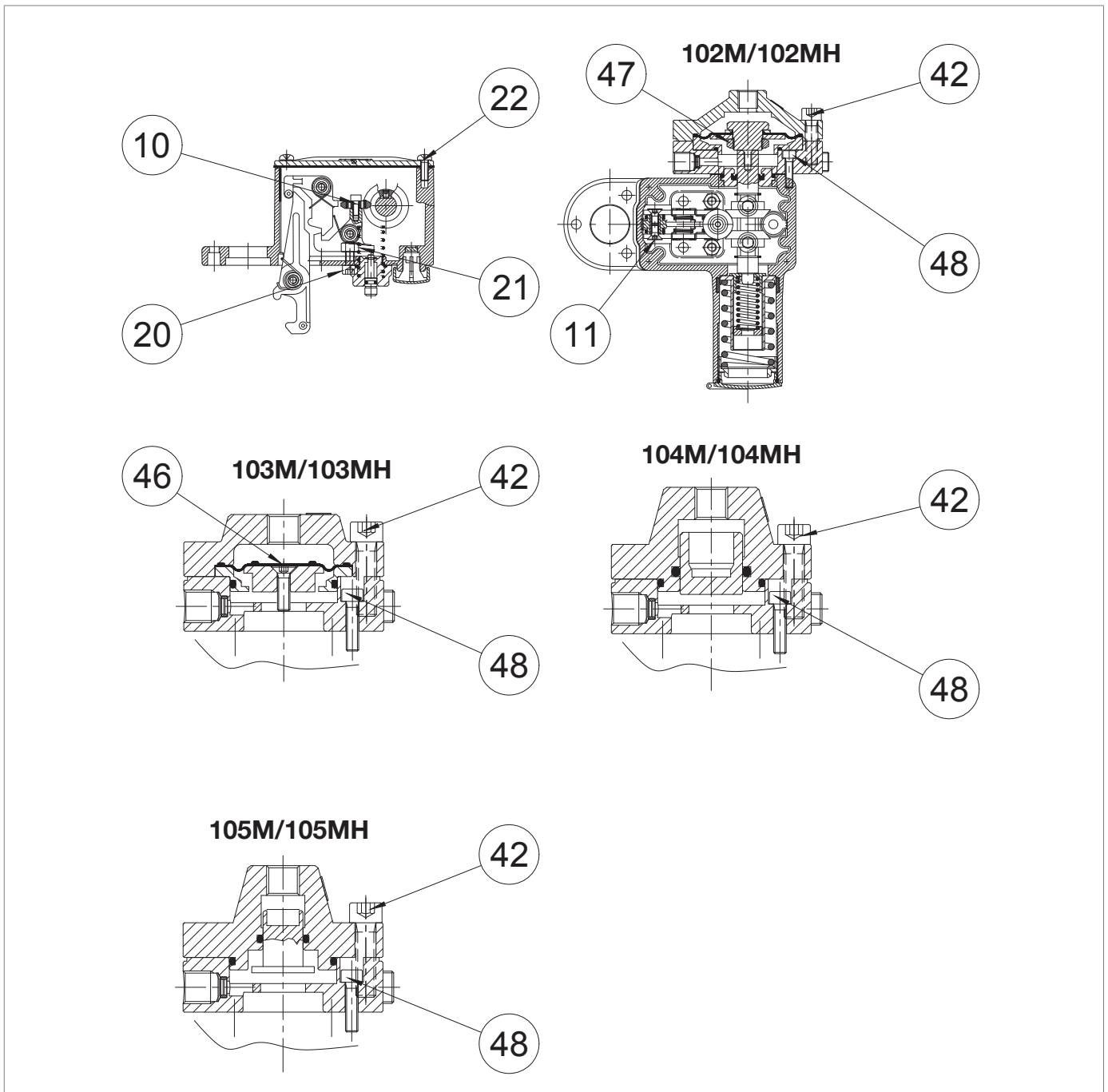

Fig. 9.37. Tightening torques for pressure switches models 102M/102MH - 105M/105MH

Mod. 102M/102MH

Pos.	Description	Torque (Nm)	Torque (ft - lb)
10	Screw M4X10 UNI 5931	3	2
11	Screw M5X10 UNI 5933	5	3
20	Screw M6X16 UNI 5931	10	7
21	Nut M6 UNI 5588	10	7
22	Screw M5X15 UNI 8112	5	3
42	Screw M6X25 UNI 5931	16	11
47	Nut M20X1	8	5
48	Screw M5X16 UNI 5931	5	3

Tab. 9.83.
Mod. 103M/103MH

Pos.	Description	Torque (Nm)	Torque (ft - lb)
10	Screw M4X10 UNI 5931	3	2
11	Screw M5X10 UNI 5933	5	3
20	Screw M6X16 UNI 5931	10	7
21	Nut M6 UNI 5588	10	7
22	Screw M5X15 UNI 8112	5	3
42	Screw M8X30 UNI 5931	16	11
46	Screw M5X18 UNI 5931	8	5
48	Screw M5X20 UNI 5931	5	3

Tab. 9.84.
Mod. 104M/104MH - 105M/105MH

Pos.	Description	Torque (Nm)	Torque (ft - lb)
10	Screw M4X10 UNI 5931	3	2
11	Screw M5X10 UNI 5933	5	3
20	Screw M6X16 UNI 5931	10	7
21	Nut M6 UNI 5588	10	7
22	Screw M5X15 UNI 8112	5	3
42	Screw M8X30 UNI 5931	16	11
48	Screw M5X20 UNI 5931	5	3

Tab. 9.85.

9.4.1.6 - TIGHTENING TORQUES FOR HP2/2 BYPASS DEVICE

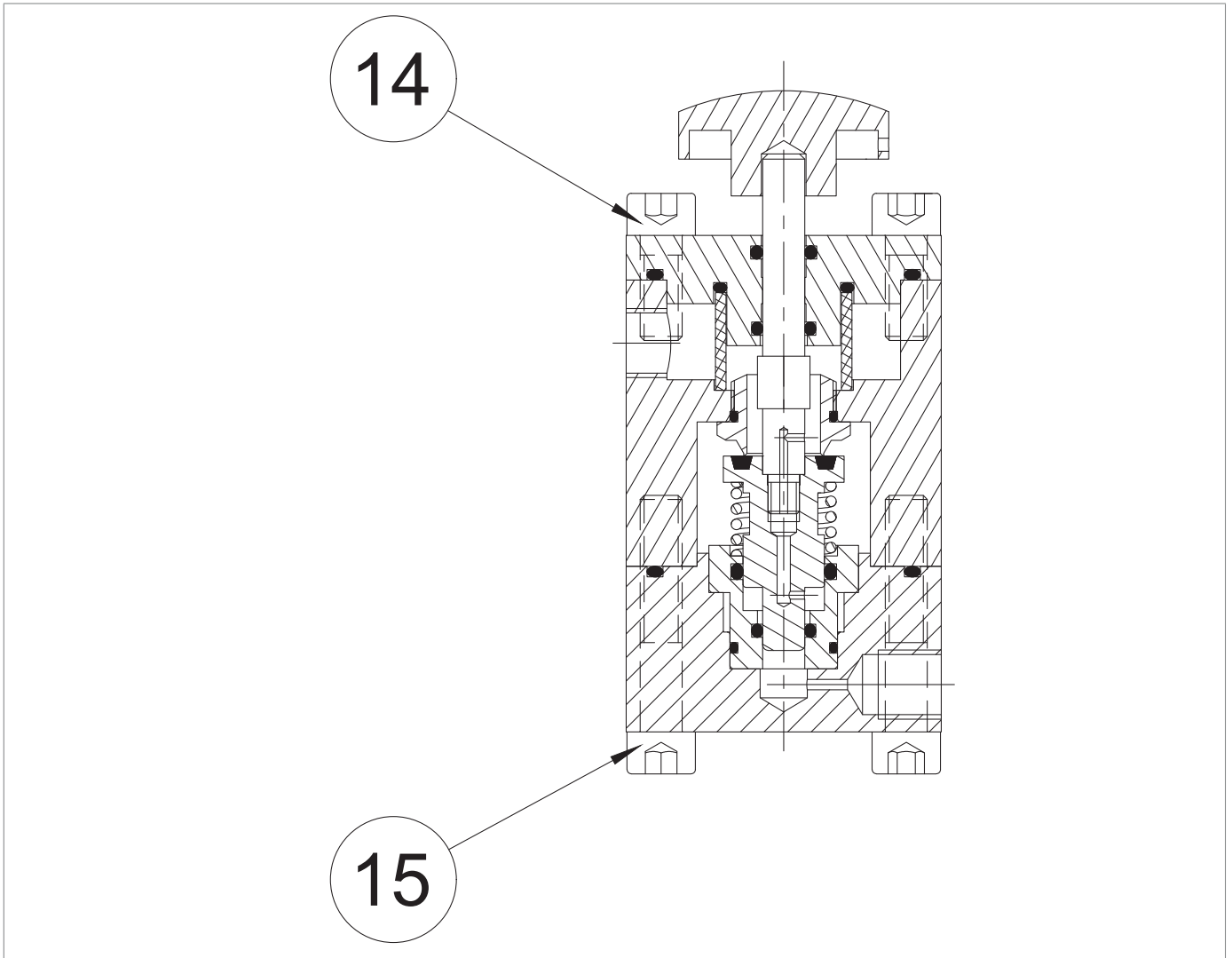

Fig. 9.38. Tightening torques for HP2/2 bypass device

HP2/2			
Pos.	Description	Torque (Nm)	Torque (ft - lb)
14	Screw M8X20 UNI 5931	16	11
15	Screw M8X45 UNI 5931	16	11

Tab. 9.86.

9.4.1.7 - TIGHTENING TORQUES FOR R44/SS REGULATOR

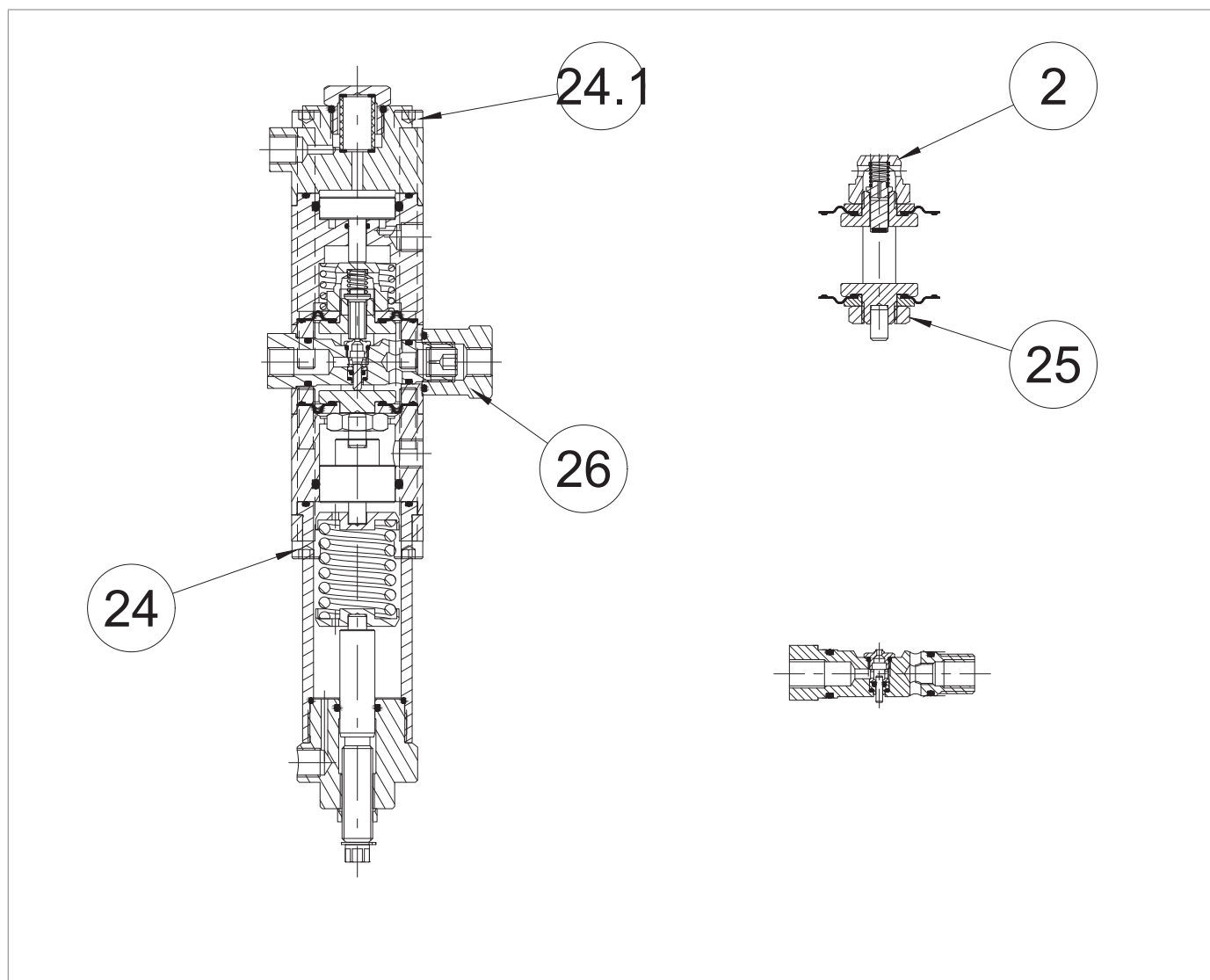

Fig. 9.39. Tightening torques for R44/SS regulator

R44/SS			
Pos.	Description	Torque (Nm)	Torque (ft - lb)
2	Nut M16X1	25	18
24	Screw M8X110 UNI 5931	16	11
24.1	Screw M8X70 UNI 5931	16	11
25	Nut M16X1.5	25	18
26	Nut M18X1.5	20	14

Tab. 9.87.

9.4.1.8 - TIGHTENING TORQUES FOR THROTTLE VALVE AR100

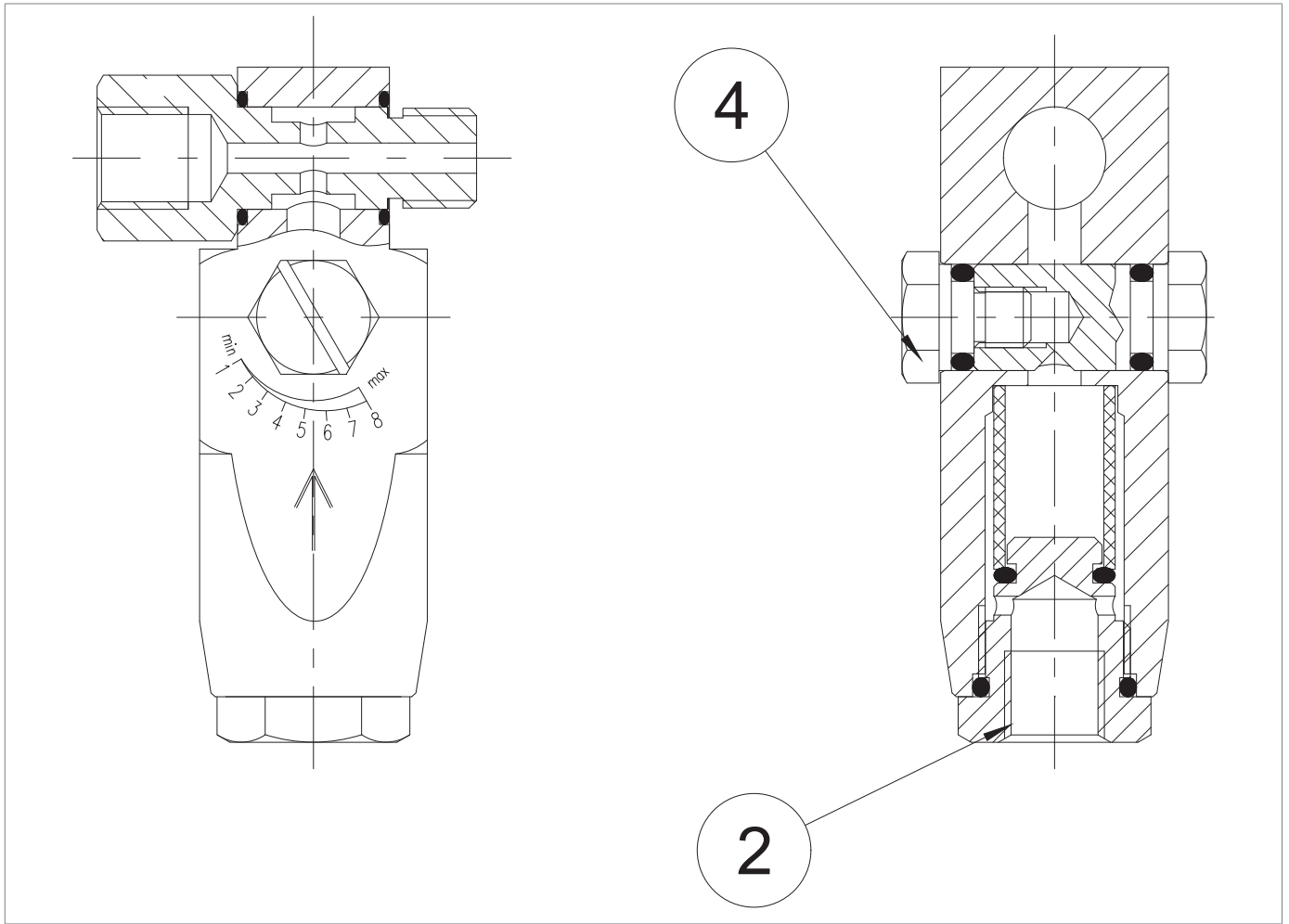

Fig. 9.40. Tightening torques for throttle valve AR100

LAMINATION VALVE AR100			
Pos.	Description	Torque (Nm)	Torque (ft - lb)
2	Cap M20X1.5	20	14
4	Screw M8	4	2

Tab. 9.88.

9.4.2 - REPLACING ELEMENTS SUBJECT TO WEAR AND ABRASION

9.4.2.1 - INITIAL OPERATIONS

WARNING!

Before any intervention, it is necessary:

- to ensure that the line on which the equipment is installed is shut off upstream and downstream;
 - to operate the slam shut valve in manual mode by pressing the release button (Pos. 10 - Figure 4.10.).
- Next, check that the pressure indicated by the pressure gauge installed on the LINE OFF 2.0 device (Pos. 7.3 - Figure 8.28.) is 0 bar, ensuring complete depressurisation of the line.

ATTENTION!

During assembly, make sure to tighten the screws as per the tables (tightening torques), according to the size for which maintenance is being carried out.

Proceed as follows:

Step	Action
1	Unscrew the conical seal fittings to disconnect all power outlets and sensing lines for the pilot and regulator.
2	Loosen the nut securing the pilot support bracket to the regulator.
3	Remove the 200/A series pilot present with the R14/A pre-regulator from the regulator.
	<div style="border: 1px solid blue; padding: 5px;">  NOTICE! For replacement and pilot disconnection procedures for the 200/A series and the R14/A pre-regulator, please refer to paragraph 9.4.6. </div>

Tab. 9.89.

9.4.2.2 - CROSS DIAGRAM FOR TIGHTENING SCREWS

To tighten the screws, when required by the maintenance procedure, refer to the following diagram:

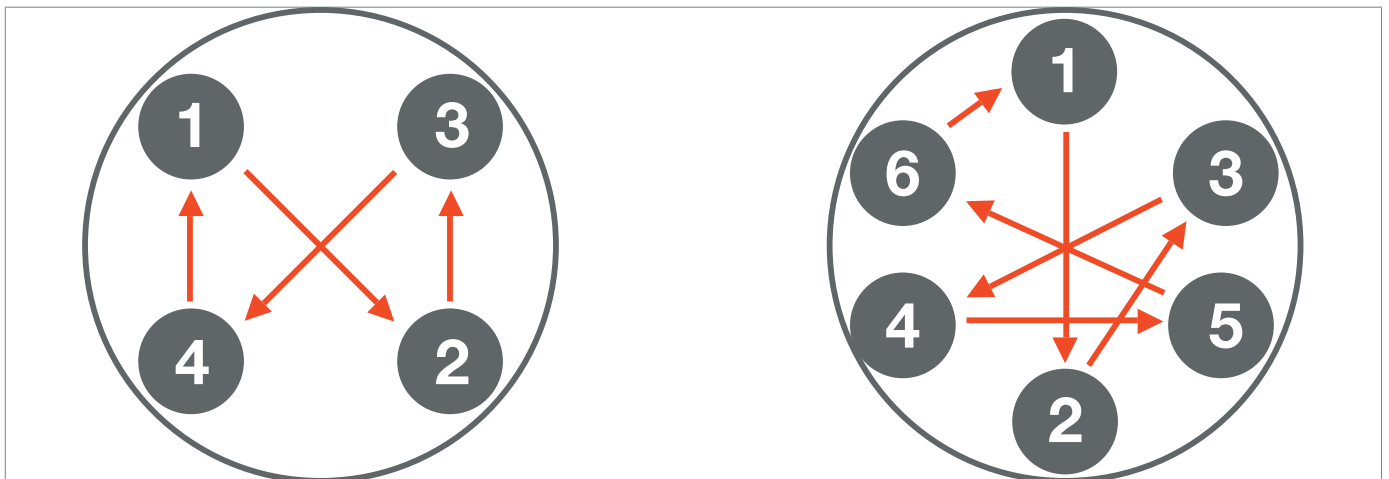

Fig. 9.41. Cross diagram

9.4.3 - REGULATOR MAINTENANCE PROCEDURE ASX 176

9.4.3.1 - REGULATOR ASX 176 1"

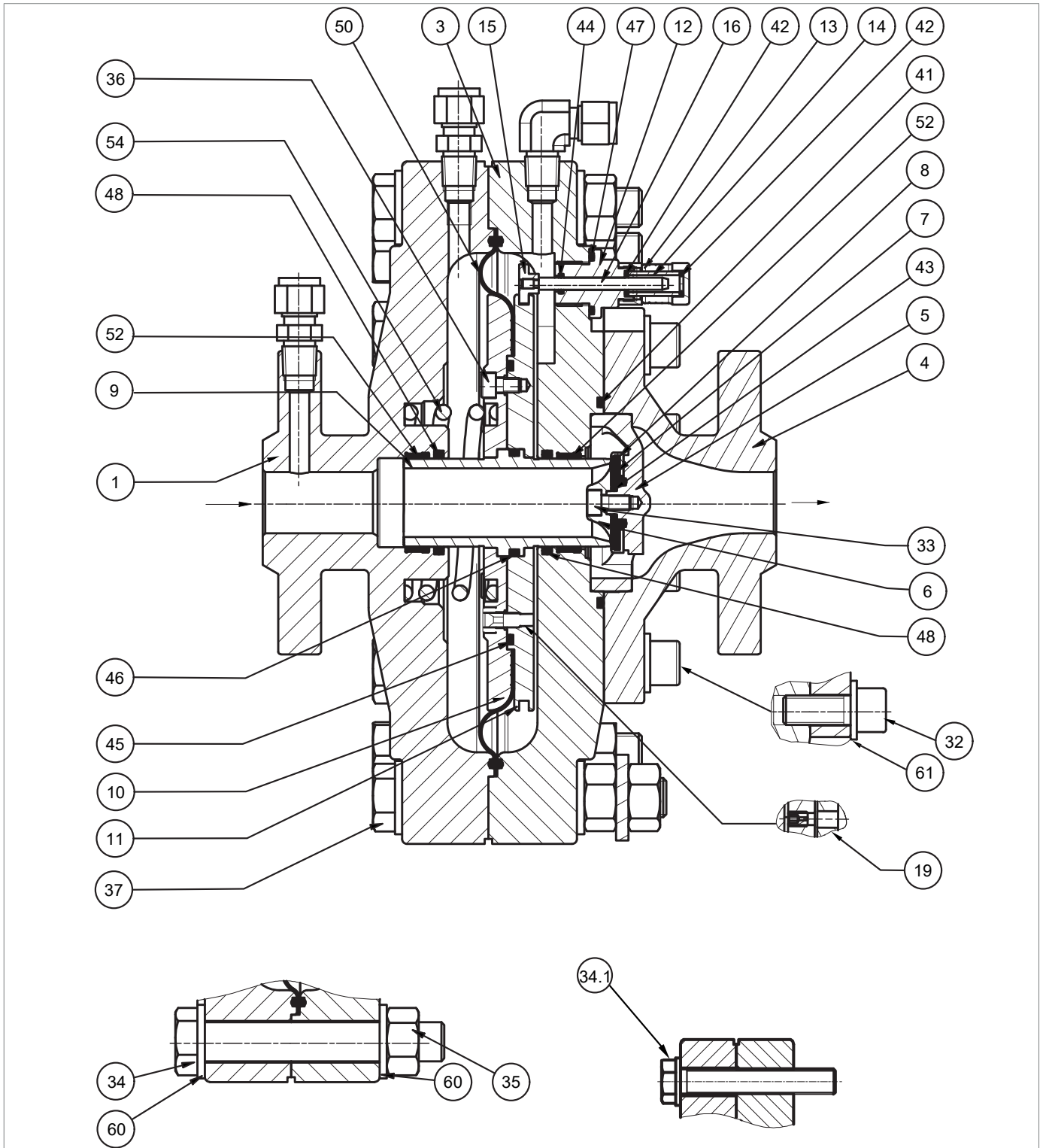





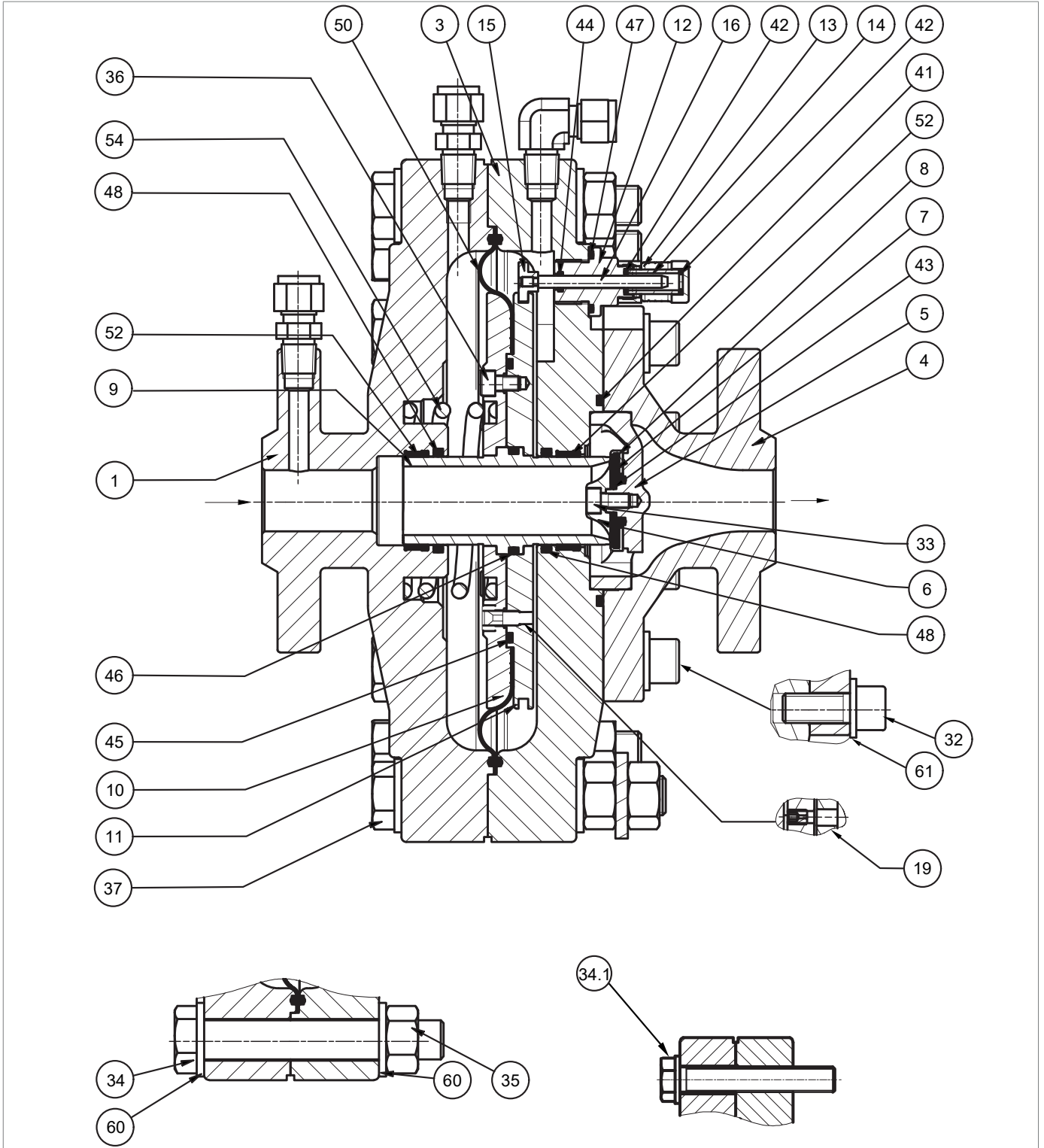

Fig. 9.42. Regulator ASX 176 1"

Step	Action
1	 WARNING! If fitted, remove the spacer.
2	Place the regulator with the upstream mouthpiece (1) of the main regulator on a shockproof surface.
3	Unscrew and remove the stroke indicator cap (13) together with the indicator slide (14) from the indicator rod guide (12).
4	Unscrew and remove the indicator rod guide (12) from the downstream cover (3).
5	Remove indicator rod assembly (15, 16) from the downstream cover (3) and diaphragm holder (11).
6	Rotate the regulator, resting the downstream mouthpiece (4) on a shockproof surface.
7	Unscrew and remove the nut (35), together with the screws (34, 37) and washers (60).
8	Undo and remove the screws (34.1) from the downstream cover (3).  NOTICE! The upstream mouthpiece (1) must remain parallel to the downstream cover (3).
9	Remove the upstream mouthpiece (1).
10	Remove the spring (54).
11	Remove the diaphragm plug assembly (9, 10, 11, 50) from the downstream cover (3).
12	Position the plug (9) from the downstream side on a shockproof surface.  NOTICE! Take care not to damage the plug.
13	Undo and remove the screws (36).  NOTICE! During this phase, prop up the diaphragm holder (11).
14	Remove the diaphragm holder (10) from the plug (9).
15	Remove and replace the diaphragm (50).
16	Remove the O-ring (45) and replace it, lubricating it with synthetic grease.  NOTICE! Before inserting the replacement O-ring, clean the retaining slots with a cleaning solution.
17	Pull the plug (9) out of the diaphragm holder (11).
18	Remove the O-ring (46) and replace it, lubricating it with synthetic grease.  NOTICE! Before inserting the replacement O-ring, clean the retaining slots with a cleaning solution.
19	Place the plug (9) in the diaphragm holder (11).
20	Position the diaphragm (50).
21	Position the diaphragm holder (10).



Regulator ASX 176 1"

Step	Action
22	<p>Insert and fix the screws (36) according to the following tightening torque:</p> <ul style="list-style-type: none"> • 1":Tab. 9.64 <p>! NOTICE!</p> <p>Tighten the screws according to the cross diagram in paragraph 9.4.2.2.</p>
23	<p>Check the hole in the transfer (19) on the diaphragm holder (10).</p> <p>! WARNING!</p> <p>Make sure the hole is not obstructed.</p>
24	<p>Remove and replace the O-ring (48) from the upstream mouthpiece (1), lubricating it with synthetic grease.</p> <p>! NOTICE!</p> <p>Before inserting the replacement O-ring, clean the retaining slots with a cleaning solution.</p>
25	<p>Remove and replace the I/DWR ring (52) from the upstream mouthpiece (1).</p> <p>! NOTICE!</p> <p>Before inserting the replacement I/DWR rings, clean the retaining slots with a cleaning solution.</p>
26	<p>Remove and replace the O-ring (48) from the downstream cover (3), lubricating it with synthetic grease.</p> <p>! NOTICE!</p> <p>Before inserting the replacement O-ring, clean the retaining slots with a cleaning solution.</p>
27	<p>Remove and replace the I/DWR ring (52) from the downstream cover (3).</p> <p>! NOTICE!</p> <p>Before inserting the replacement I/DWR rings, clean the retaining slots with a cleaning solution.</p>
28	<p>Turn the downstream cover assembly (3) and the downstream mouthpiece (4) upside down, placing the cover on an impact-resistant surface.</p>
29	<p>Undo the screws (32) together with the washers (61).</p>
30	<p>Remove the downstream mouthpiece (4).</p>
31	<p>Remove the reinforced gasket assembly (4, 5, 6, 7, 8, 33, 43) from the downstream mouthpiece (4).</p>
32	<p>Unscrew and remove the screw (33) together with the shaft collar (6) from the reinforced gasket assembly.</p>
33	<p>Remove gasket ring holder (8), gasket ring (7) and O-ring (43) from the gasket holder (5).</p>
34	<p>Replace the O-ring (43), lubricating it with synthetic grease.</p> <p>! NOTICE!</p> <p>Before inserting the replacement O-ring, clean the retaining slots with a cleaning solution.</p>
35	<p>Remove and replace the gasket ring (7) from the gasket ring holder (8).</p>
36	<p>Position the gasket ring support (8) and gasket ring (7) in the reinforced gasket assembly.</p>

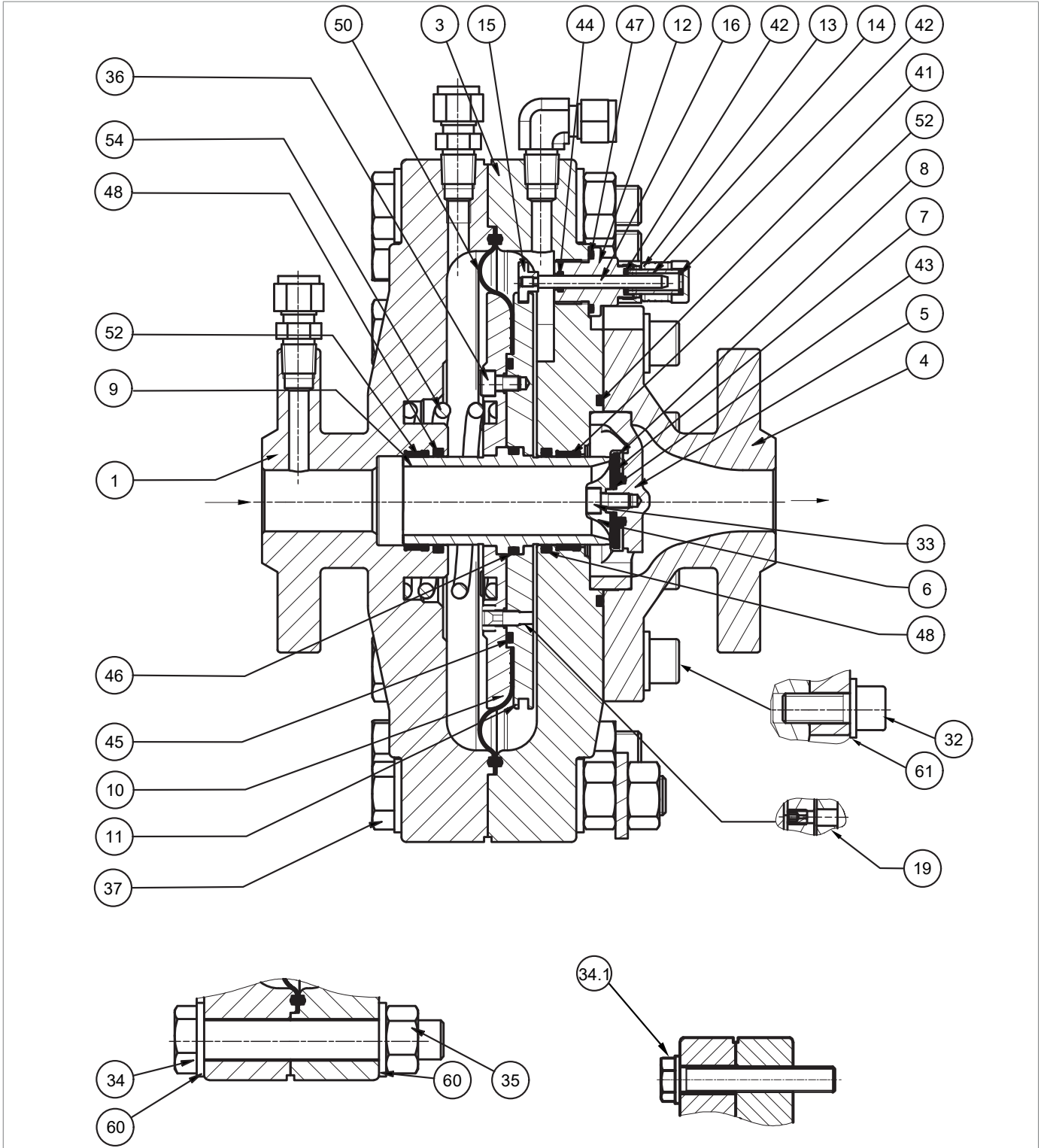

Regulator ASX 176 1"

Step	Action
37	<p>Insert and fasten the screw (33) together with the shaft collar (6) according to the tightening torque:</p> <ul style="list-style-type: none"> • 1":Tab. 9.64 <p>NOTICE!</p> <p>Tighten the screws according to the cross diagram in paragraph 9.4.2.2.</p>
38	<p>Remove the O-ring (41) and replace it, lubricating it with synthetic grease.</p> <p>NOTICE!</p> <p>Before inserting the replacement O-ring, clean the retaining slots with a cleaning solution.</p>
39	Place the reinforced gasket assembly (4, 5, 6, 7, 8, 33, 43) in the downstream cover (3).
40	Place the downstream mouthpiece (4) in the downstream cover (3).
41	<p>Insert and fasten the screws (32) together with the washers (61) according to the tightening torque:</p> <ul style="list-style-type: none"> • 1":Tab. 9.64 <p>NOTICE!</p> <p>Tighten the screws according to the cross diagram in paragraph 9.4.2.2.</p>
42	Turn the downstream cover assembly (3) and the downstream mouthpiece (4) upside down, placing the mouthpiece on an impact-resistant surface.
43	<p>Insert the diaphragm plug assembly (9, 10, 11, 50) into the downstream cover (3).</p> <p>NOTICE!</p> <p>Take care not to damage the O-ring (48), the I/DWR (52) and the plug profile (9).</p>
44	Fit the spring (54).
45	<p>Place the upstream mouthpiece (1) in the plug (9).</p> <p>NOTICE!</p> <p>Take care not to damage the O-ring (48) and the I/DWR (52).</p>
46	<p>Insert and fasten the screws (34.1) in the two threaded holes of the downstream cover (3) to compress the spring (54), and hold the mouthpiece (1) parallel to the downstream cover (3), according to the tightening torque:</p> <ul style="list-style-type: none"> • 1":Tab. 9.64 <p>NOTICE!</p> <p>Take care not to tilt the upstream mouthpiece (1) when fastening the screws (34.1).</p>
47	Bring the upstream mouthpiece (1) with the downstream cover (3) into position.
48	<p>Insert and secure the remaining screws (34) and screw (37) together with the washers (60) with the nut (35) in accordance with the tightening torque:</p> <ul style="list-style-type: none"> • 1":Tab. 9.64 <p>NOTICE!</p> <p>Tighten the screws according to the cross diagram in paragraph 9.4.2.2.</p>
49	Rotate the regulator, resting the downstream mouthpiece (4) on a shockproof surface.

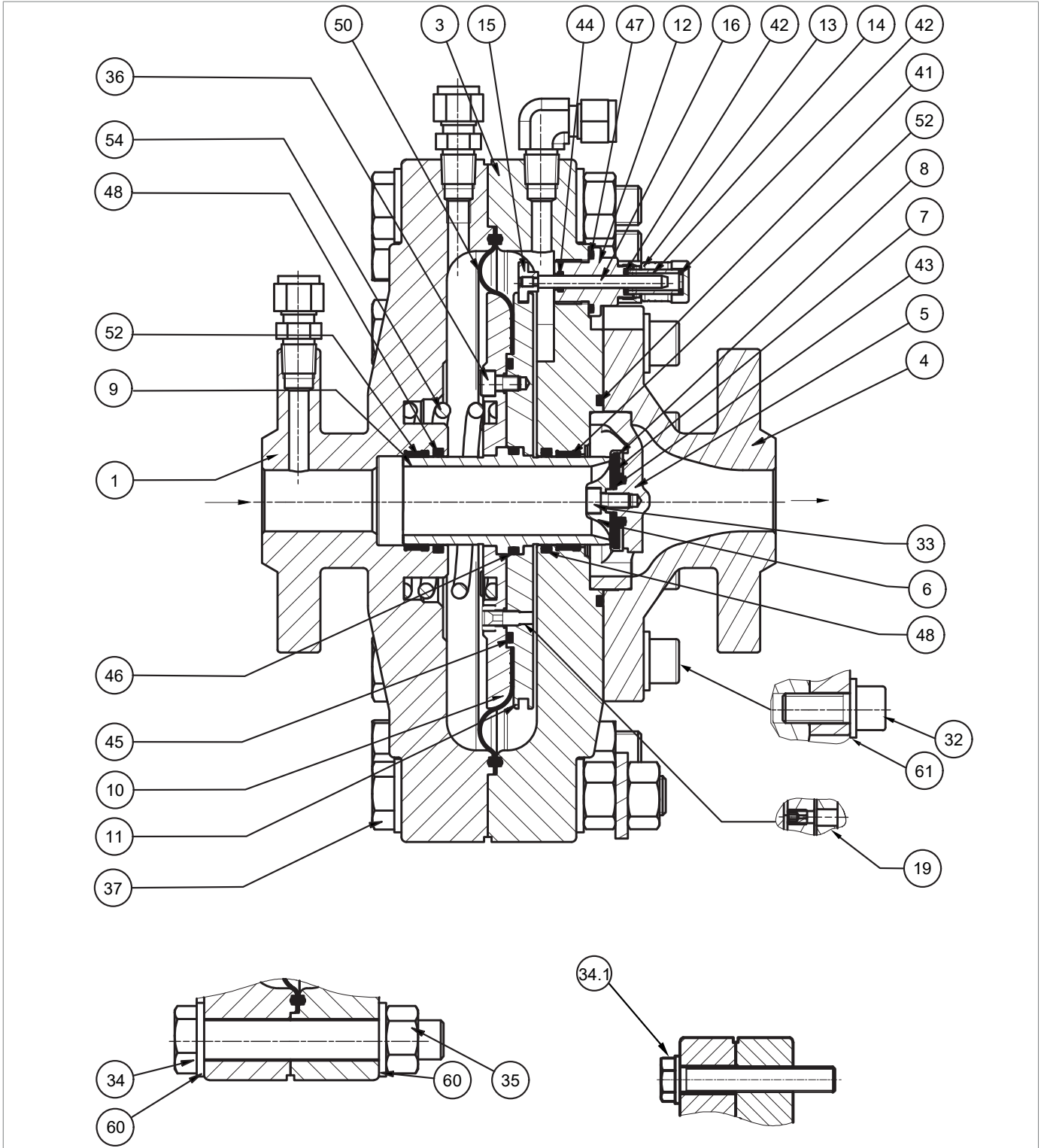

Regulator ASX 176 1"

Step	Action
50	<p>Remove and replace the O-rings (42, 44, 47) from the indicator rod guide (12), lubricating them with synthetic grease.</p> <div style="border: 1px solid black; padding: 5px;"> <p>! NOTICE!</p> <p>Before inserting the replacement O-rings, clean the retaining slots with a cleaning solution.</p> </div>
51	<p>Remove and replace the O-ring (42) from the stroke indicator cap (13), lubricating it with synthetic grease.</p> <div style="border: 1px solid black; padding: 5px;"> <p>! NOTICE!</p> <p>Before inserting the replacement O-ring, clean the retaining slots with a cleaning solution.</p> </div>
52	Insert the indicator rod assembly (15, 16) into the downstream cover (3).
53	Hook the extension (15) into the diaphragm holder (11).
54	Insert and screw the indicator rod guide (12) into the downstream cover (3).
55	Insert and secure the stroke indicator cap (13) together with the stroke indicator slide (14) in the indicator rod guide (12).







Tab. 9.90.

! NOTICE!

After maintenance, reposition the regulator and spacer (if present) in line following the procedure indicated in paragraph "6.5 - Equipment installation procedure".

! WARNING!

Ensure that all parts have been fitted correctly.

Step	Action
1	 WARNING! If fitted, remove the spacer.
2	Place the regulator with the upstream mouthpiece (1) of the main regulator on a shockproof surface.
3	Unscrew and remove the stroke indicator cap (13) together with the indicator slide (14) from the indicator rod guide (12).
4	Unscrew and remove the indicator rod guide (12) from the downstream cover (3).
5	Remove indicator rod assembly (15, 16) from the downstream cover (3) and diaphragm holder (11).
6	Rotate the regulator, resting the downstream mouthpiece (4) on a shockproof surface.
7	Unscrew and remove the nut (35), together with the screws (34, 37) and washers (60)
8	Undo and remove the screws (34.1) from the downstream cover (3).  NOTICE! The upstream mouthpiece (1) and cover (2) assembly must remain parallel to the downstream cover (3).
9	Separate the upstream cover (2) from the downstream cover (3).  NOTICE! Place the upstream cover (2) on the side of the upstream mouthpiece (1).
10	Remove the spring (54).
11	Remove the diaphragm plug assembly (9, 10, 11, 50) from the downstream cover (3).
12	Position the plug (9) from the downstream side on a shockproof surface.  NOTICE! Take care not to damage the plug (9).
13	Undo and remove the screws (36).  NOTICE! During this phase, prop up the diaphragm holder (11).
14	Remove the diaphragm holder (10) from the plug (9).
15	Remove and replace the diaphragm (50).
16	Remove the O-ring (45) and replace it, lubricating it with synthetic grease.  NOTICE! Before inserting the replacement O-ring, clean the retaining slots with a cleaning solution.
17	Pull the plug (9) out of the diaphragm holder (11).
18	Remove the O-ring (46) and replace it, lubricating it with synthetic grease.  NOTICE! Before inserting the replacement O-ring, clean the retaining slots with a cleaning solution.
19	Place the plug (9) in the diaphragm holder (11).
20	Position the diaphragm (50).
21	Position the diaphragm holder (10).

Step	Action
22	<p>Insert and fix the screws (36) according to the following tightening torque:</p> <ul style="list-style-type: none"> • 2": Tab. 9.66 • 3": Tab. 9.67 • 4": Tab. 9.68 • 6": Tab. 9.69 <p>NOTICE! Tighten the screws according to the cross diagram in paragraph 9.4.2.2.</p>
23	<p>Check the hole in the transfer (19) on the diaphragm holder (10).</p> <p>WARNING! Make sure the hole is not obstructed.</p>
24	Undo and remove the screws (31).
25	Separate the upstream cover (2) from the upstream mouthpiece (1).
26	<p>Remove and replace the O-rings (40, 48) from the upstream mouthpiece (1), lubricating them with synthetic grease.</p> <p>NOTICE! Before inserting the replacement O-rings, clean the retaining slots with a cleaning solution.</p>
27	<p>Remove and replace the I/DWR ring (52) from the upstream mouthpiece (1).</p> <p>NOTICE! Before inserting the replacement I/DWR rings, clean the retaining slots with a cleaning solution.</p>
28	Place upstream cover (2) in upstream mouthpiece (1).
29	<p>Insert and fix the screws (31) according to the following tightening torque:</p> <ul style="list-style-type: none"> • 2": Tab. 9.66 • 3": Tab. 9.67 • 4": Tab. 9.68 • 6": Tab. 9.69 <p>NOTICE! Tighten the screws according to the cross diagram in paragraph 9.4.2.2.</p>
30	<p>Remove and replace the O-ring (48) from the downstream cover (3), lubricating it with synthetic grease.</p> <p>NOTICE! Before inserting the replacement O-ring, clean the retaining slots with a cleaning solution.</p>
31	<p>Remove and replace the I/DWR ring (52) from the downstream cover (3).</p> <p>NOTICE! Before inserting the replacement I/DWR ring, clean the retaining slots with a cleaning solution.</p>
32	Turn the downstream cover assembly (3) and downstream mouthpiece (4) upside down, placing the cover on an impact-resistant surface.
33	Undo the screws (32) together with the washers (61).

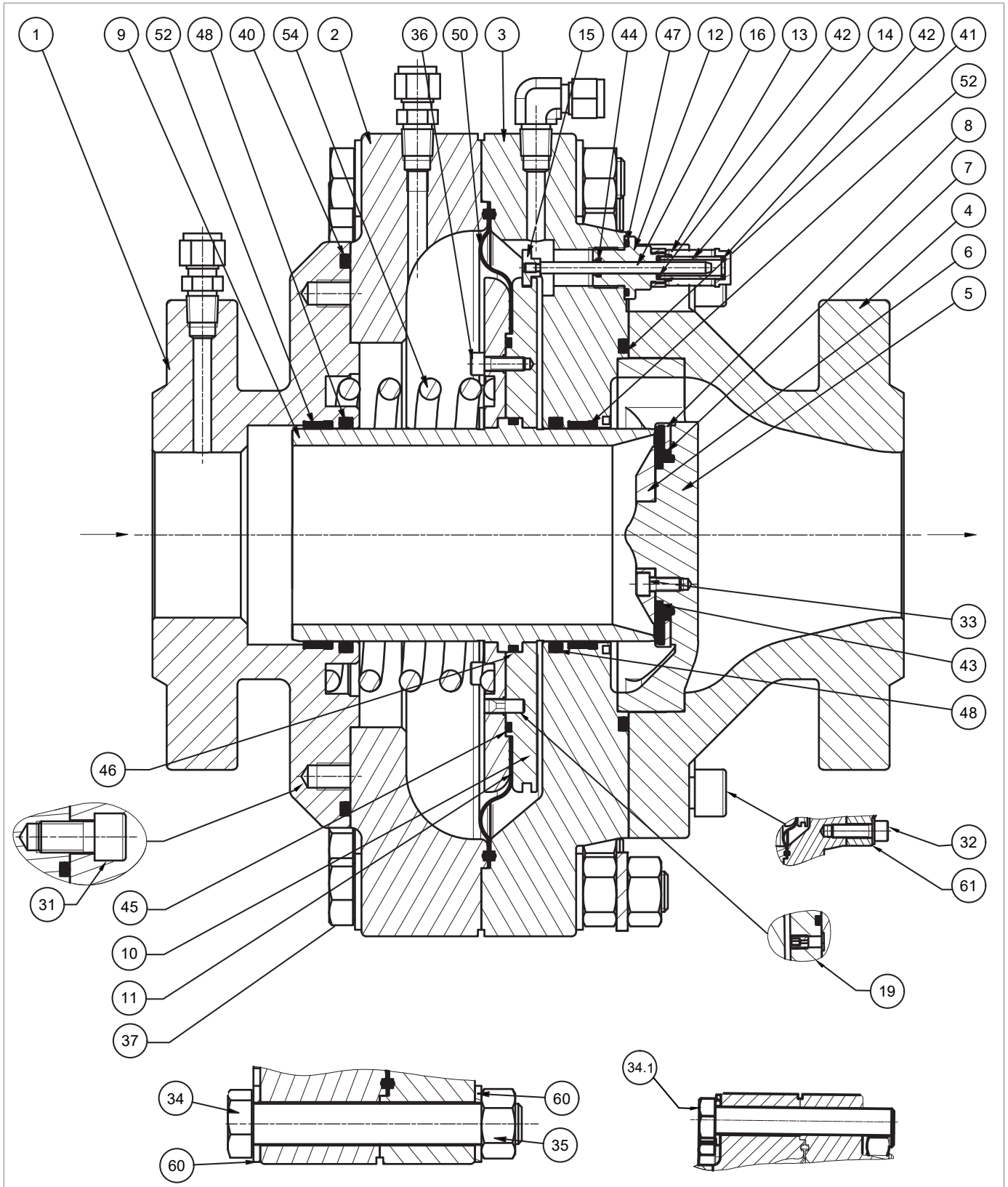

Regulator ASX 176 2'' - 6''

Step	Action
34	Remove the downstream mouthpiece (4).
35	Remove the reinforced gasket assembly (4, 5, 6, 7, 8, 33, 43) from the downstream mouthpiece (4).
36	Unscrew and remove the screws (33) together with the shaft collar (6) from the gasket support (5).
37	Remove gasket ring holder (8), gasket ring (7) and O-ring (43) from the gasket holder (5).
38	Replace the O-ring (43), lubricating it with synthetic grease. <div style="border: 1px solid black; padding: 5px;">! NOTICE! Before inserting the replacement O-ring, clean the retaining slots with a cleaning solution.</div>
39	Remove and replace the gasket ring (7) from the gasket ring holder (8).
40	Place the gasket ring holder (8) and the gasket ring (7) in the gasket holder (5).
41	Insert and fasten the screws (33) together with the shaft collar (6) according to the tightening torque: <ul style="list-style-type: none"> • 2": Tab. 9.66 • 3": Tab. 9.67 • 4": Tab. 9.68 • 6": Tab. 9.69 <div style="border: 1px solid black; padding: 5px;">! NOTICE! Tighten the screws according to the cross diagram in paragraph 9.4.2.2.</div>
42	Remove and replace the O-ring (41) from the downstream cover (3), lubricating it with synthetic grease. <div style="border: 1px solid black; padding: 5px;">! NOTICE! Before inserting the replacement O-ring, clean the retaining slots with a cleaning solution.</div>
43	Place the reinforced gasket assembly (4, 5, 6, 7, 8, 33, 43) in the downstream cover (3).
44	Place the downstream mouthpiece (4) in the downstream cover (3).
45	Insert and fasten the screws (32) together with the washers (61) according to the tightening torque: <ul style="list-style-type: none"> • 2": Tab. 9.66 • 3": Tab. 9.67 • 4": Tab. 9.68 • 6": Tab. 9.69 <div style="border: 1px solid black; padding: 5px;">! NOTICE! Tighten the screws according to the cross diagram in paragraph 9.4.2.2.</div>
46	Turn the downstream cover assembly (3) and the downstream mouthpiece (4) upside down, placing the mouthpiece on an impact-resistant surface.
47	Insert the diaphragm plug assembly (9, 10, 11, 50) into the downstream cover (3). <div style="border: 1px solid black; padding: 5px;">! NOTICE! Take care not to damage the O-ring (48), the I/DWR (52) and the plug profile (9).</div>
48	Fit the spring (54).
49	Place the upstream cover (2) and the upstream mouthpiece (1) in the plug (9). <div style="border: 1px solid black; padding: 5px;">! NOTICE! Take care not to damage the O-ring (48) and the I/DWR (52).</div>

Step	Action
50	<p>Insert and fasten the screws (34.1) in the two threaded holes of the downstream cover (3) to compress the spring (54), and hold the upstream mouthpiece (1) and cover (2) assembly parallel to the downstream cover (3), according to the tightening torque:</p> <ul style="list-style-type: none"> • 2": Tab. 9.66 • 3": Tab. 9.67 • 4": Tab. 9.68 • 6": Tab. 9.69 <p>NOTICE! Take care not to tilt the top cover (2) when fastening the screws (34.1).</p>
51	<p>Place the downstream cover (3) in position with the upstream cover (2).</p> <p>NOTICE! Ensure that the diaphragm lanyard (50) remains in place.</p>
52	<p>Insert and secure the remaining screws (34) and screw (37) together with the washers (60) with the nut (35) in accordance with the tightening torque:</p> <ul style="list-style-type: none"> • 2": Tab. 9.66 • 3": Tab. 9.67 • 4": Tab. 9.68 • 6": Tab. 9.69 <p>NOTICE! Tighten the screws according to the cross diagram in paragraph 9.4.2.2.</p>
53	<p>Rotate the regulator, resting the downstream mouthpiece (4) on a shockproof surface.</p>
54	<p>Remove and replace the O-rings (42, 44, 47) from the indicator rod guide (12), lubricating them with synthetic grease.</p> <p>NOTICE! Before inserting the replacement O-rings, clean the retaining slots with a cleaning solution.</p>
55	<p>Remove and replace the O-ring (42) from the stroke indicator cap (13), lubricating it with synthetic grease.</p> <p>NOTICE! Before inserting the replacement O-ring, clean the retaining slots with a cleaning solution.</p>
56	<p>Insert the indicator rod assembly (15, 16) into the downstream cover (3).</p>
57	<p>Hook the extension (15) into the diaphragm holder (11).</p>
58	<p>Insert and screw the indicator rod guide (12) into the downstream cover (3).</p>
59	<p>Insert and secure the stroke indicator cap (13) together with the indicator slide (14) in the indicator rod guide (12).</p>

Tab. 9.91.

NOTICE!

After maintenance, reposition the regulator and spacer (if present) in line following the procedure indicated in paragraph "6.5 - Equipment installation procedure".

WARNING!

Ensure that all parts have been fitted correctly.

9.4.4 - MAINTENANCE PROCEDURE REGULATOR ASX 176 WITH SILENCER LDB/176

9.4.4.1 - REGULATOR ASX 176 WITH SILENCER LDB/176 1"

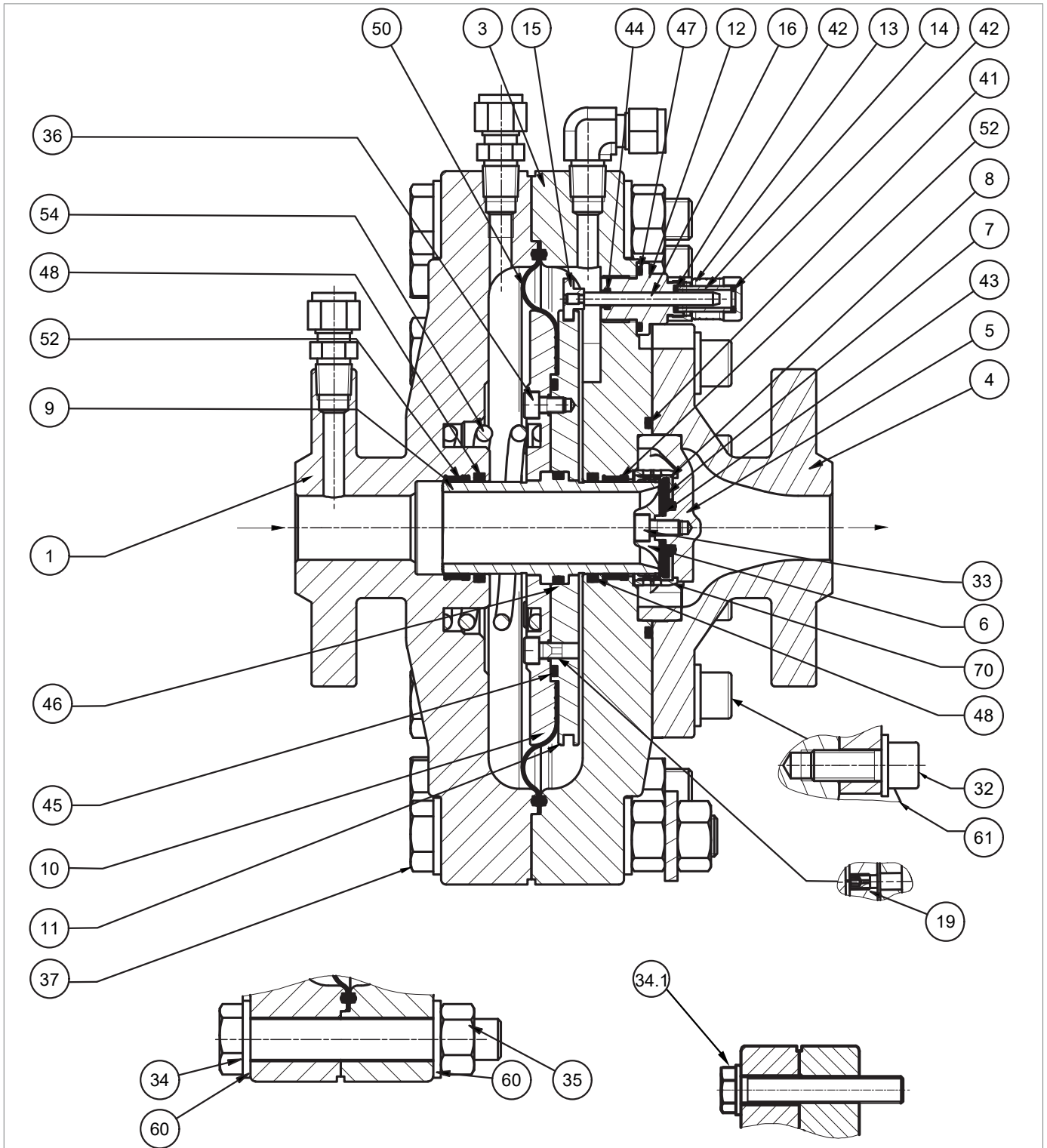

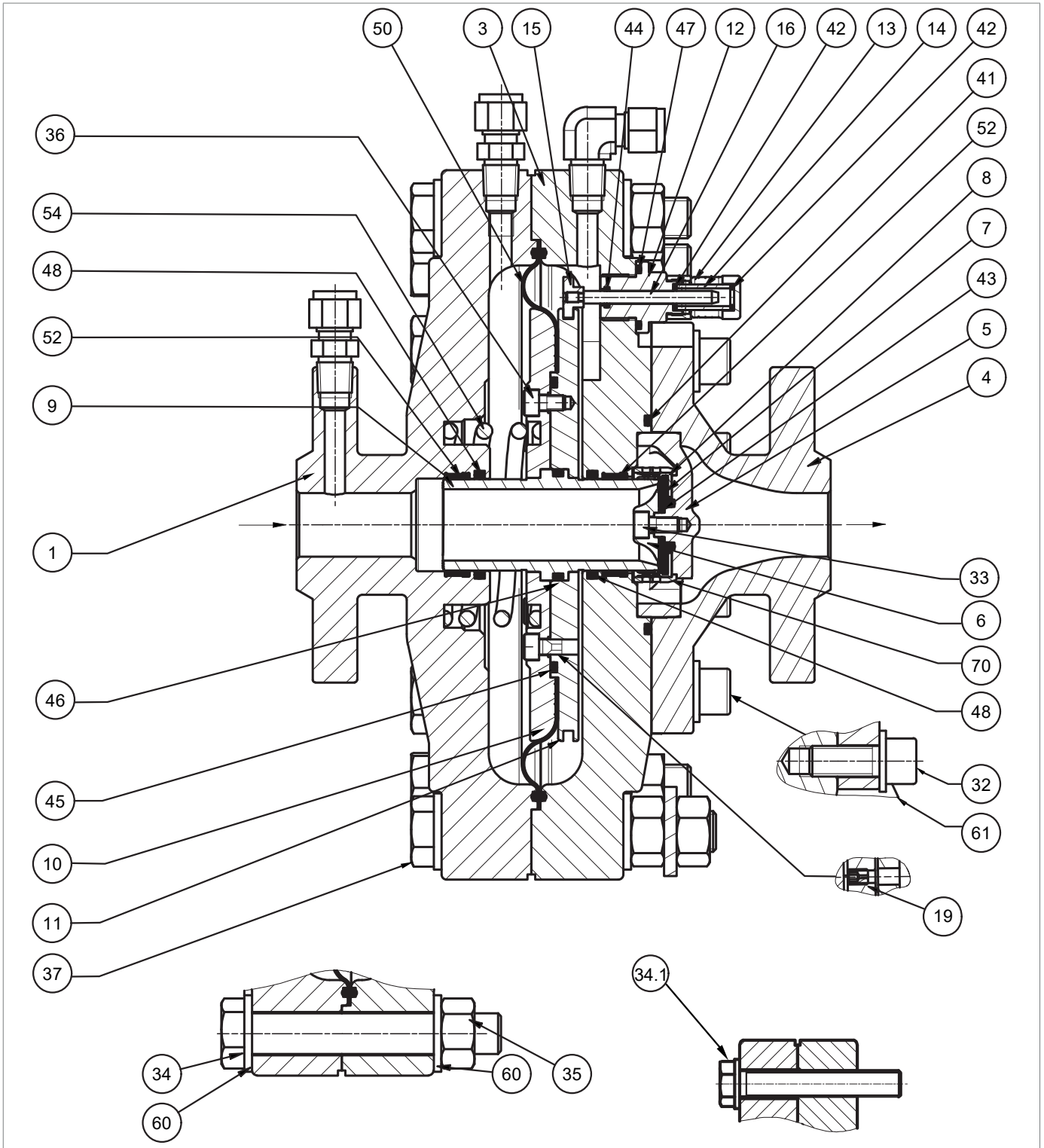









Fig. 9.44. Regulator ASX 176 with silencer LDB/176 1"

Step	Action
1	 WARNING! If fitted, remove the spacer.
2	Place the regulator with the downstream mouthpiece (4) of the main regulator on a shockproof surface.
3	Unscrew and remove the stroke indicator cap (13) together with the indicator slide (14) from the indicator rod guide (12).
4	Unscrew and remove the indicator rod guide (12) from the downstream cover (3).
5	Remove indicator rod assembly (15, 16) from the downstream cover (3) and diaphragm holder (11).
6	Rotate the regulator, resting the downstream mouthpiece (4) on a shockproof surface.
7	Unscrew and remove the nut (35), together with the screws (34, 37) and washers (60).
8	Undo and remove the screws (34.1) from the downstream cover (3).  NOTICE! The upstream mouthpiece (1) must remain parallel to the downstream cover (3).
9	Remove the spring (54).
10	Remove the diaphragm plug assembly (9, 10, 11, 50) from the downstream cover (3).
11	Position the plug (9) from the downstream side on a shockproof surface.  NOTICE! Take care not to damage the plug (9).
12	Undo and remove the screws (36).  NOTICE! During this phase, prop up the diaphragm holder (11).
13	Remove the diaphragm holder (10) from the plug (9).
14	Remove and replace the diaphragm (50).
15	Remove the O-ring (45) and replace it, lubricating it with synthetic grease.  NOTICE! Before inserting the replacement O-ring, clean the retaining slots with a cleaning solution.
16	Pull the plug (9) out of the diaphragm holder (11).
17	Remove the O-ring (46) and replace it, lubricating it with synthetic grease.  NOTICE! Before inserting the replacement O-ring, clean the retaining slots with a cleaning solution.
18	Place the plug (9) in the diaphragm holder (11).
19	Position the diaphragm (50).
20	Position the diaphragm holder (10).
21	Insert and fix the screws (36) according to the following tightening torque: <ul style="list-style-type: none"> • 1": Tab. 9.70  NOTICE! Tighten the screws according to the cross diagram in paragraph 9.4.2.2.







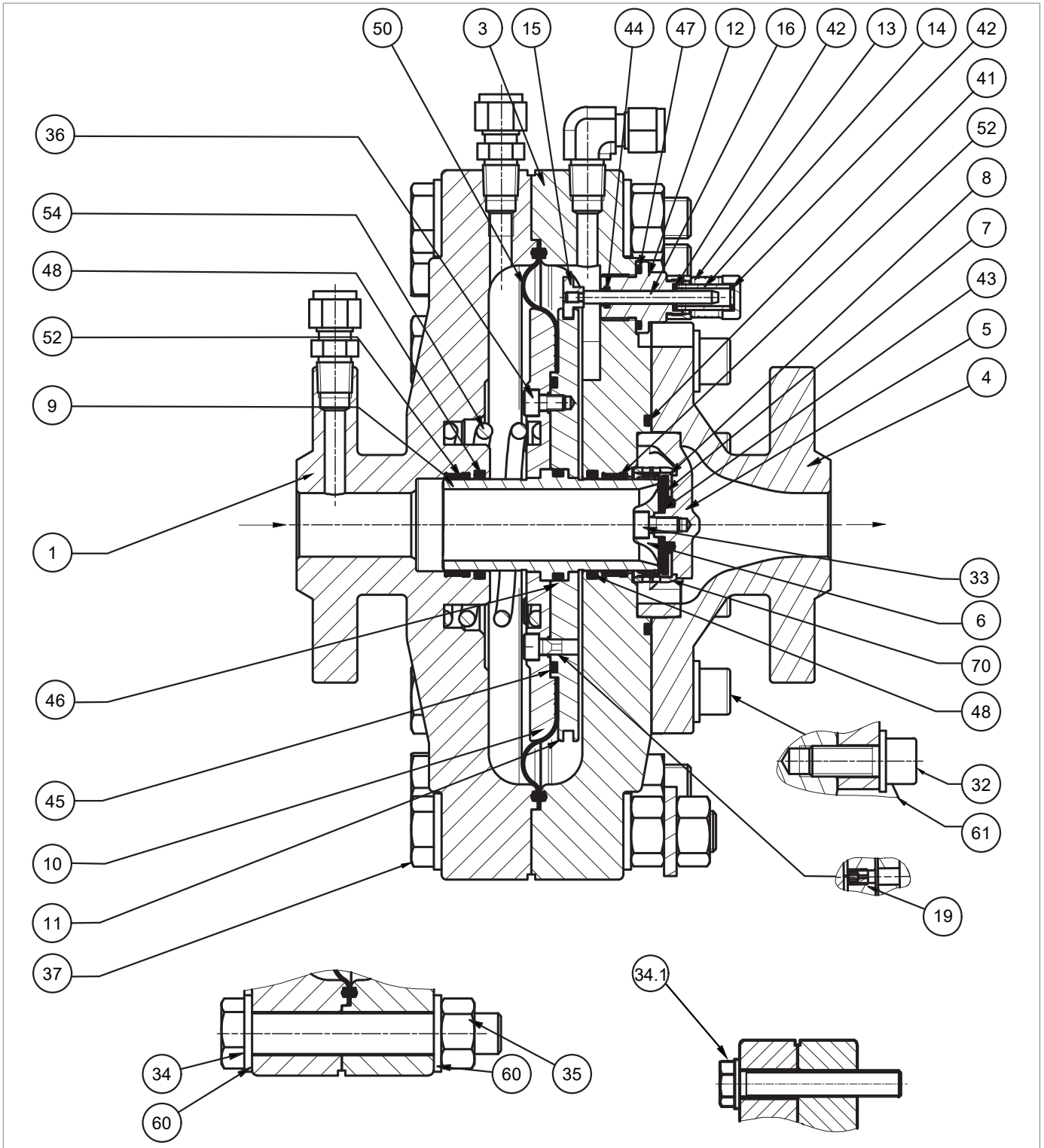



Regulator ASX 176 with silencer LDB/176 1"

Step	Action
22	<p>Check the hole in the transfer (19) on the diaphragm holder (10).</p> <p> WARNING! Make sure the hole is not obstructed.</p>
23	<p>Remove and replace the O-ring (48) from the upstream mouthpiece (1), lubricating it with synthetic grease.</p> <p> NOTICE! Before inserting the replacement O-ring, clean the retaining slots with a cleaning solution.</p>
24	<p>Remove and replace the I/DWR ring (52) from the upstream mouthpiece (1).</p> <p> NOTICE! Before inserting the replacement I/DWR ring, clean the retaining slots with a cleaning solution.</p>
25	<p>Remove and replace the O-ring (48) from the downstream cover (3), lubricating it with synthetic grease.</p> <p> NOTICE! Before inserting the replacement O-ring, clean the retaining slots with a cleaning solution.</p>
26	<p>Remove and replace the I/DWR ring (52) from the downstream cover (3).</p> <p> NOTICE! Before inserting the replacement I/DWR ring, clean the retaining slots with a cleaning solution.</p>
27	Turn the downstream cover assembly (3) and downstream mouthpiece (4) upside down, placing the downstream cover on an impact-resistant surface
28	Undo the screws (32) together with the washers (61).
29	Remove the downstream mouthpiece (4).
30	Remove the reinforced gasket assembly (4, 5, 6, 7, 8, 33, 43) together with the LDB/176 grid (70) from the downstream mouthpiece (4).
31	Unscrew and remove the screw (33) together with the shaft collar (6) from the reinforced gasket assembly.
32	Remove gasket ring holder (8), gasket ring (7) and O-ring (43) from the gasket holder (5).
33	Remove grid LDB/176 (70).
34	<p>Replace the O-ring (43), lubricating it with synthetic grease.</p> <p> NOTICE! Before inserting the replacement O-ring, clean the retaining slots with a cleaning solution.</p>
35	Remove and replace the gasket ring (7) from the gasket ring holder (8).
36	Position grid LDB/176 (70).
37	Position the gasket ring support (8) and gasket ring (7) in the reinforced gasket assembly.
38	<p>Insert and fasten the screw (33) together with the shaft collar (6) according to the tightening torque:</p> <ul style="list-style-type: none"> • 1": Tab. 9.70 <p> NOTICE! Tighten the screws according to the cross diagram in paragraph 9.4.2.2.</p>



Regulator ASX 176 with silencer LDB/176 1"

Step	Action
39	Remove the O-ring (41) and replace it, lubricating it with synthetic grease.  NOTICE! Before inserting the replacement O-ring, clean the retaining slots with a cleaning solution.
40	Place the reinforced gasket assembly (4, 5, 6, 7, 8, 33, 43) in the downstream cover (3).
41	Place the downstream mouthpiece (4) in the downstream cover (3).
42	Insert and fasten the screws (32) together with the washers (61) according to the tightening torque: <ul style="list-style-type: none"> 1": Tab. 9.70  NOTICE! Tighten the screws according to the cross diagram in paragraph 9.4.2.2.
43	Turn the downstream cover assembly (3) and downstream mouthpiece (4) upside down.
44	Insert the diaphragm plug assembly (9, 10, 11, 50) into the downstream cover (3).  NOTICE! Take care not to damage the O-ring (48), the I/DWR (52) and the plug profile (9).
45	Fit the spring (54).
46	Place the upstream mouthpiece (1) in the plug (9).  NOTICE! Take care not to damage the O-ring (48) and the I/DWR (52).
47	Insert and fasten the screws (34.1) in the two threaded holes of the downstream cover (3) to compress the spring (54) and hold the upstream mouthpiece (1) parallel to the downstream cover (3), according to the tightening torque: <ul style="list-style-type: none"> 1": Tab. 9.70  NOTICE! Take care not to tilt the upstream mouthpiece (1) when fastening the screws (34.1).
48	Bring the upstream mouthpiece (1) with the downstream cover (3) into position.
49	Insert and secure the remaining screws (34) and screw (37) together with the washers (60) with the nut (35) in accordance with the tightening torque: <ul style="list-style-type: none"> 1": Tab. 9.70  NOTICE! Tighten the screws according to the cross diagram in paragraph 9.4.2.2.
50	Rotate the regulator, resting the downstream mouthpiece (4) on a shockproof surface
51	Remove and replace the O-rings (42, 44, 47) from the indicator rod guide (12), lubricating them with synthetic grease.  NOTICE! Before inserting the replacement O-rings, clean the retaining slots with a cleaning solution.
52	Remove and replace the O-ring (42) from the stroke indicator cap (13), lubricating it with synthetic grease.  NOTICE! Before inserting the replacement O-ring, clean the retaining slots with a cleaning solution.

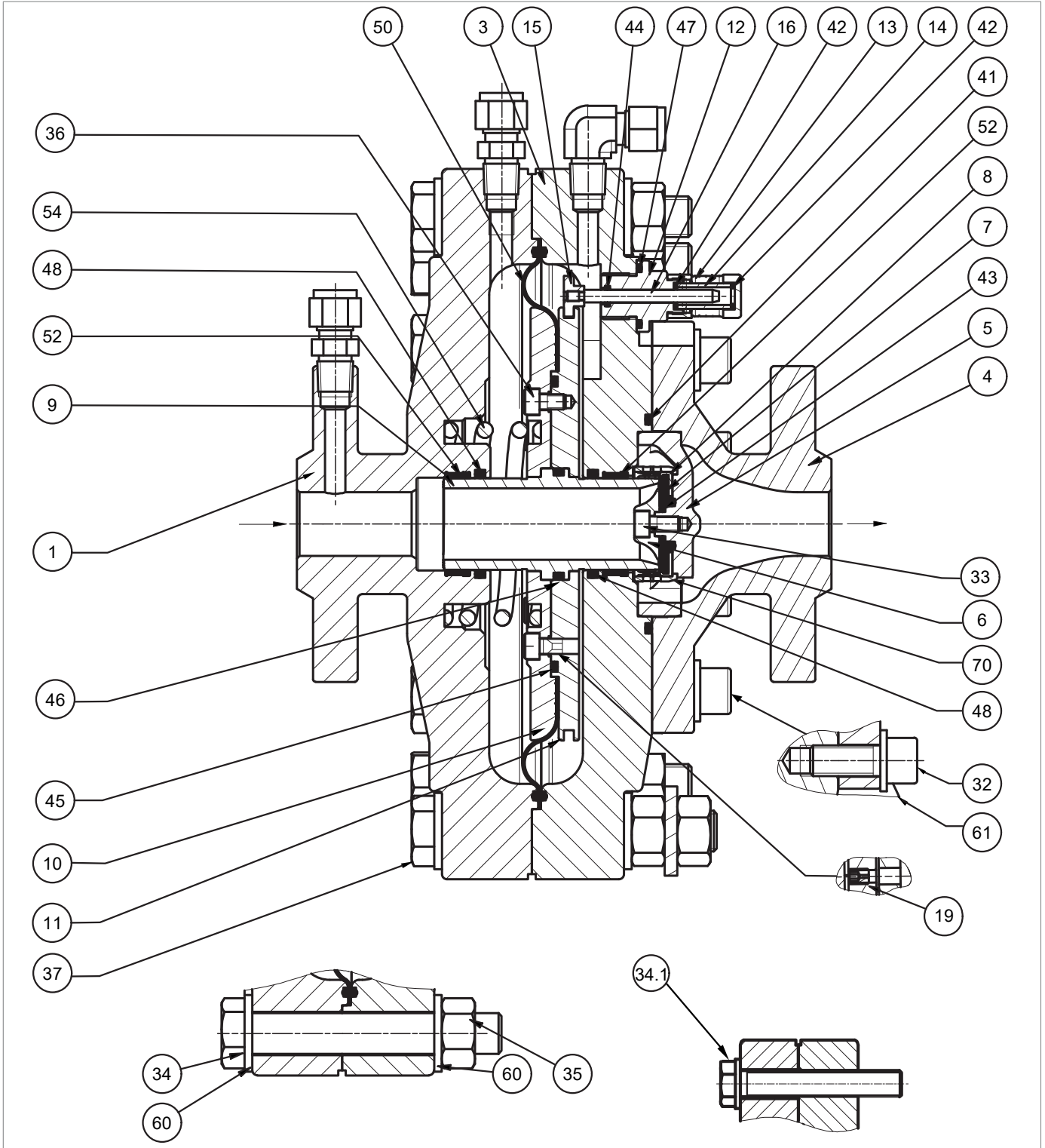

Regulator ASX 176 with silencer LDB/176 1"

Step	Action
53	Insert the indicator rod assembly (15, 16) into the downstream cover (3).
54	Hook the extension (15) into the diaphragm holder (11).
55	Insert and screw the indicator rod guide (12) into the downstream cover (3).
56	Insert and secure the stroke indicator cap (13) together with the indicator slide (14) in the indicator rod guide (12).

Tab. 9.92.

 **NOTICE!**

After maintenance, reposition the regulator and spacer (if present) in line following the procedure indicated in paragraph "6.5 - Equipment installation procedure".

 **WARNING!**

Ensure that all parts have been fitted correctly.

9.4.4.2 - REGULATOR ASX 176 WITH SILENCER LDB/176 2" - 6"

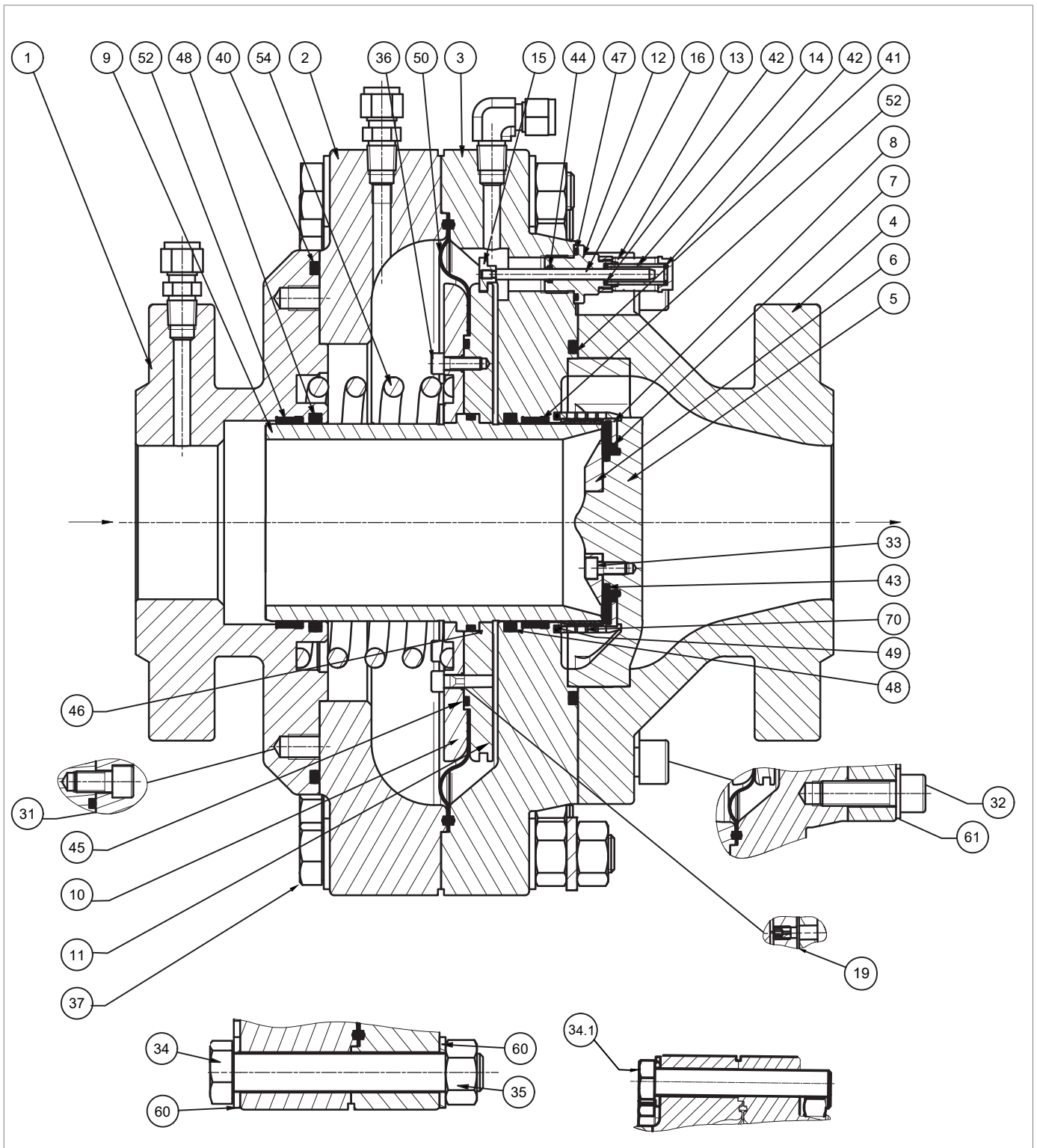







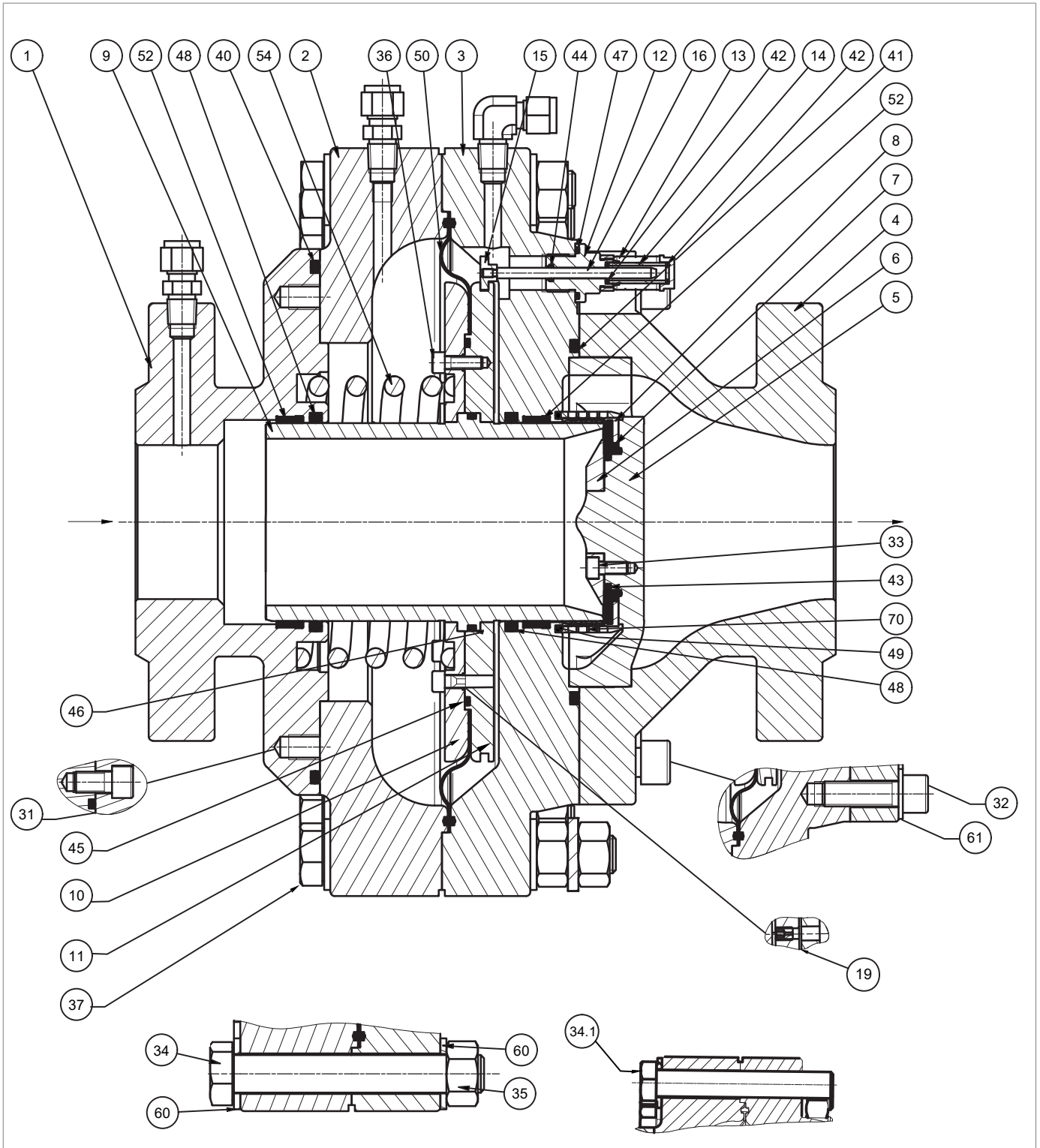

Fig. 9.45. Regulator ASX 176 with silencer LDB/176 2" - 6"

Step	Action
1	 WARNING! If fitted, remove the spacer.
2	Place the regulator with the downstream mouthpiece (4) of the main regulator on a shockproof surface.
3	Unscrew and remove the stroke indicator cap (13) together with the indicator slide (14) from the indicator rod guide (12).
4	Unscrew and remove the indicator rod guide (12) from the downstream cover (3).
5	Remove indicator rod assembly (15, 16) from the downstream cover (3) and diaphragm holder (11).
6	Rotate the regulator, resting the downstream mouthpiece (4) on a shockproof surface.
7	Unscrew and remove the nut (35), together with the screws (34, 37) and washers (60).
8	Undo and remove the screws (34.1) from the downstream cover (3).  NOTICE! The upstream mouthpiece (1) and upstream cover (2) assembly must remain parallel to the downstream cover (3).
9	Separate the upstream cover (2) from the downstream cover (3).  NOTICE! Place the cover (2) on the side of the mouthpiece (1).
10	Remove the spring (54).
11	Remove the diaphragm plug assembly (9, 10, 11, 50) from the downstream cover (3).
12	Position the plug (9) from the downstream side on a shockproof surface.  NOTICE! Take care not to damage the plug (9).
13	Undo and remove the screws (36).  NOTICE! During this phase, prop up the diaphragm holder (11).
14	Remove the diaphragm holder (10) from the plug (9).
15	Remove and replace the diaphragm (50).
16	Remove the O-ring (45) and replace it, lubricating it with synthetic grease.  NOTICE! Before inserting the replacement O-ring, clean the retaining slots with a cleaning solution.
17	Pull the plug (9) out of the diaphragm holder (11).
18	Remove the O-ring (46) and replace it, lubricating it with synthetic grease.  NOTICE! Before inserting the replacement O-ring, clean the retaining slots with a cleaning solution.
19	Place the plug (9) in the diaphragm holder (11).
20	Position the diaphragm (50).
21	Position the diaphragm holder (10).



Regulator ASX 176 with silencer LDB/176 2" - 6"

Step	Action
22	<p>Insert and fix the screws (36) according to the following tightening torque:</p> <ul style="list-style-type: none"> • 2": Tab. 9.71 • 3": Tab. 9.72 • 4": Tab. 9.73 • 6": Tab. 9.74 <div style="border: 1px solid black; padding: 5px;"> <p>! NOTICE!</p> <p>Tighten the screws according to the cross diagram in paragraph 9.4.2.2.</p> </div>
23	<p>Check the hole in the transfer (19) on the diaphragm holder (10).</p> <div style="background-color: #f4a460; padding: 5px;"> <p>! WARNING!</p> <p>Make sure the hole is not obstructed.</p> </div>
24	Undo and remove the screws (31).
25	Separate the upstream cover (2) from the upstream mouthpiece (1).
26	<p>Remove and replace the O-rings (40, 48) from the upstream mouthpiece (1), lubricating them with synthetic grease.</p> <div style="border: 1px solid black; padding: 5px;"> <p>! NOTICE!</p> <p>Before inserting the replacement O-rings, clean the retaining slots with a cleaning solution.</p> </div>
27	<p>Remove and replace the I/DWR ring (52) from the upstream mouthpiece (1).</p> <div style="border: 1px solid black; padding: 5px;"> <p>! NOTICE!</p> <p>Before inserting the replacement I/DWR ring, clean the retaining slots with a cleaning solution.</p> </div>
28	Place upstream cover (2) in upstream mouthpiece (1).
29	<p>Insert and fix the screws (31) according to the following tightening torque:</p> <ul style="list-style-type: none"> • 2": Tab. 9.71 • 3": Tab. 9.72 • 4": Tab. 9.73 • 6": Tab. 9.74 <div style="border: 1px solid black; padding: 5px;"> <p>! NOTICE!</p> <p>Tighten the screws according to the cross diagram in paragraph 9.4.2.2.</p> </div>
30	<p>Remove and replace the O-rings (48) from the downstream cover (3), lubricating them with synthetic grease.</p> <div style="border: 1px solid black; padding: 5px;"> <p>! NOTICE!</p> <p>Before inserting the replacement O-ring, clean the retaining slots with a cleaning solution.</p> </div>
31	<p>Remove and replace the I/DWR ring (52) from the downstream cover (3).</p> <div style="border: 1px solid black; padding: 5px;"> <p>! NOTICE!</p> <p>Before inserting the replacement I/DWR ring, clean the retaining slots with a cleaning solution.</p> </div>
32	Turn the downstream cover assembly (3) and the downstream mouthpiece (4) upside down, placing the downstream cover on an impact-resistant surface.
33	Undo the screws (32) together with the washers (61).
34	Remove the downstream mouthpiece (4).

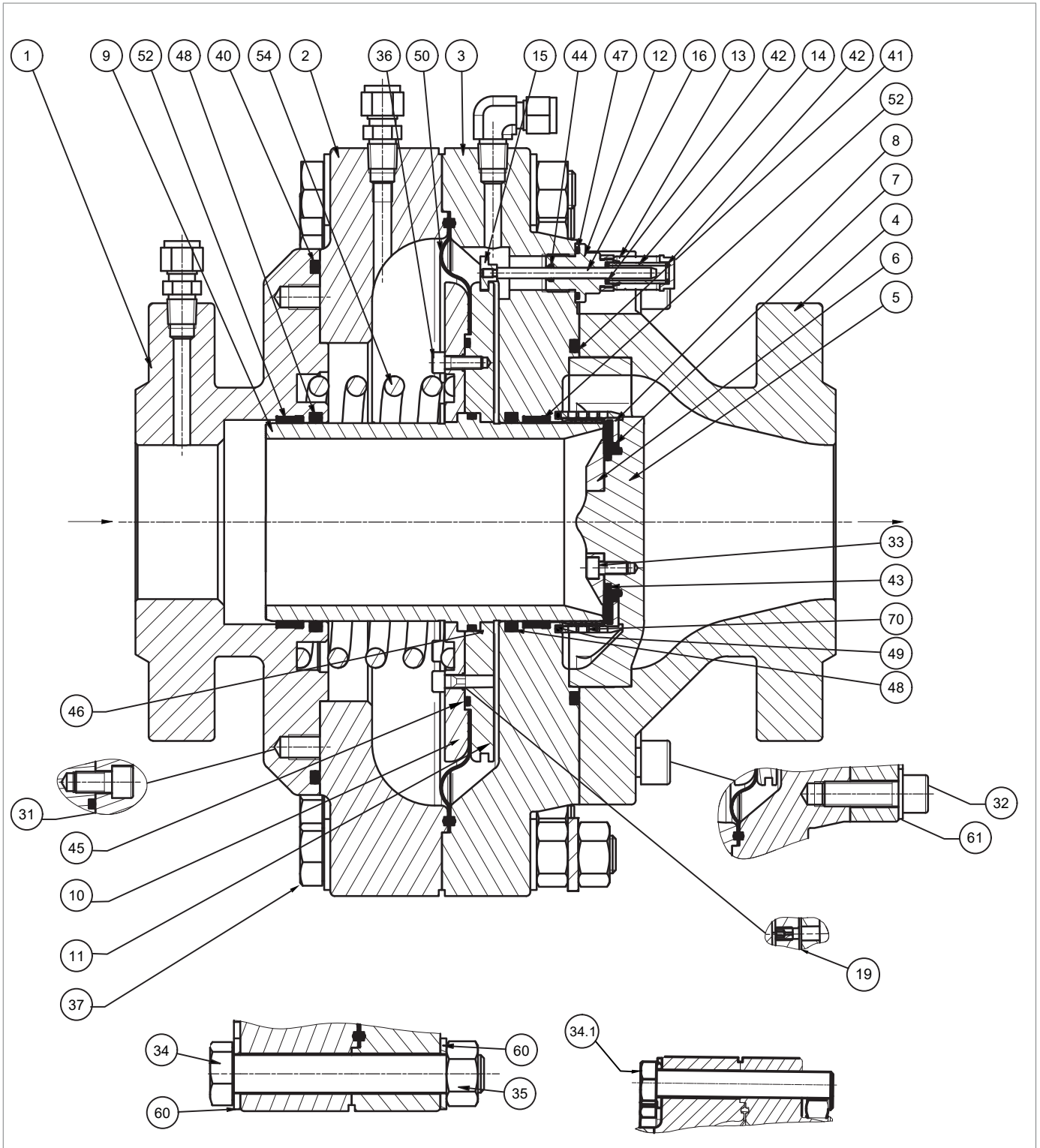

Regulator ASX 176 with silencer LDB/176 2" - 6"

Step	Action
35	Remove the reinforced gasket assembly (4, 5, 6, 7, 8, 33, 43) together with the LDB/176 grid (70) from the downstream mouthpiece (4).
36	Remove and replace the O-rings (49) from the downstream cover (3) by lubricating them with synthetic grease. ! NOTICE! Before inserting the replacement O-rings, clean the retaining slots with a cleaning solution.
37	Unscrew and remove the screws (33) together with the shaft collar (6) from the gasket support (5).
38	Remove the ring (8), reinforced gasket (7) and O-ring (43) from the gasket support (5).
39	Remove grid LDB/176 (70).
40	Replace the O-ring (43), lubricating it with synthetic grease. ! NOTICE! Before inserting the replacement O-ring, clean the retaining slots with a cleaning solution.
41	Remove and replace the gasket ring (7) from the gasket ring holder (8).
42	Position grid LDB/176 (70).
43	Place the gasket ring holder (8) and the gasket ring (7) in the gasket holder (5).
44	Insert and fasten the screws (33) together with the shaft collar (6) according to the tightening torque: <ul style="list-style-type: none"> • 2": Tab. 9.71 • 3": Tab. 9.72 • 4": Tab. 9.73 • 6": Tab. 9.74 ! NOTICE! Tighten the screws according to the cross diagram in paragraph 9.4.2.2.
45	Remove and replace the O-ring (41) from the downstream cover (3), lubricating it with synthetic grease. ! NOTICE! Before inserting the replacement O-ring, clean the retaining slots with a cleaning solution.
46	Place the reinforced gasket assembly in the downstream cover (3).
47	Place the downstream mouthpiece (4) in the downstream cover (3).
48	Insert and fasten the screws (32) together with the washers (61) according to the tightening torque: <ul style="list-style-type: none"> • 2": Tab. 9.71 • 3": Tab. 9.72 • 4": Tab. 9.73 • 6": Tab. 9.74 ! NOTICE! Tighten the screws according to the cross diagram in paragraph 9.4.2.2.
49	Turn the downstream cover assembly (3) and the downstream mouthpiece (4) upside down, placing the downstream mouthpiece on an impact-resistant surface.
50	Insert the diaphragm plug assembly (9, 10, 11, 50) into the downstream cover (3). ! NOTICE! Take care not to damage the O-ring (48), the I/DWR (52) and the plug profile (9).

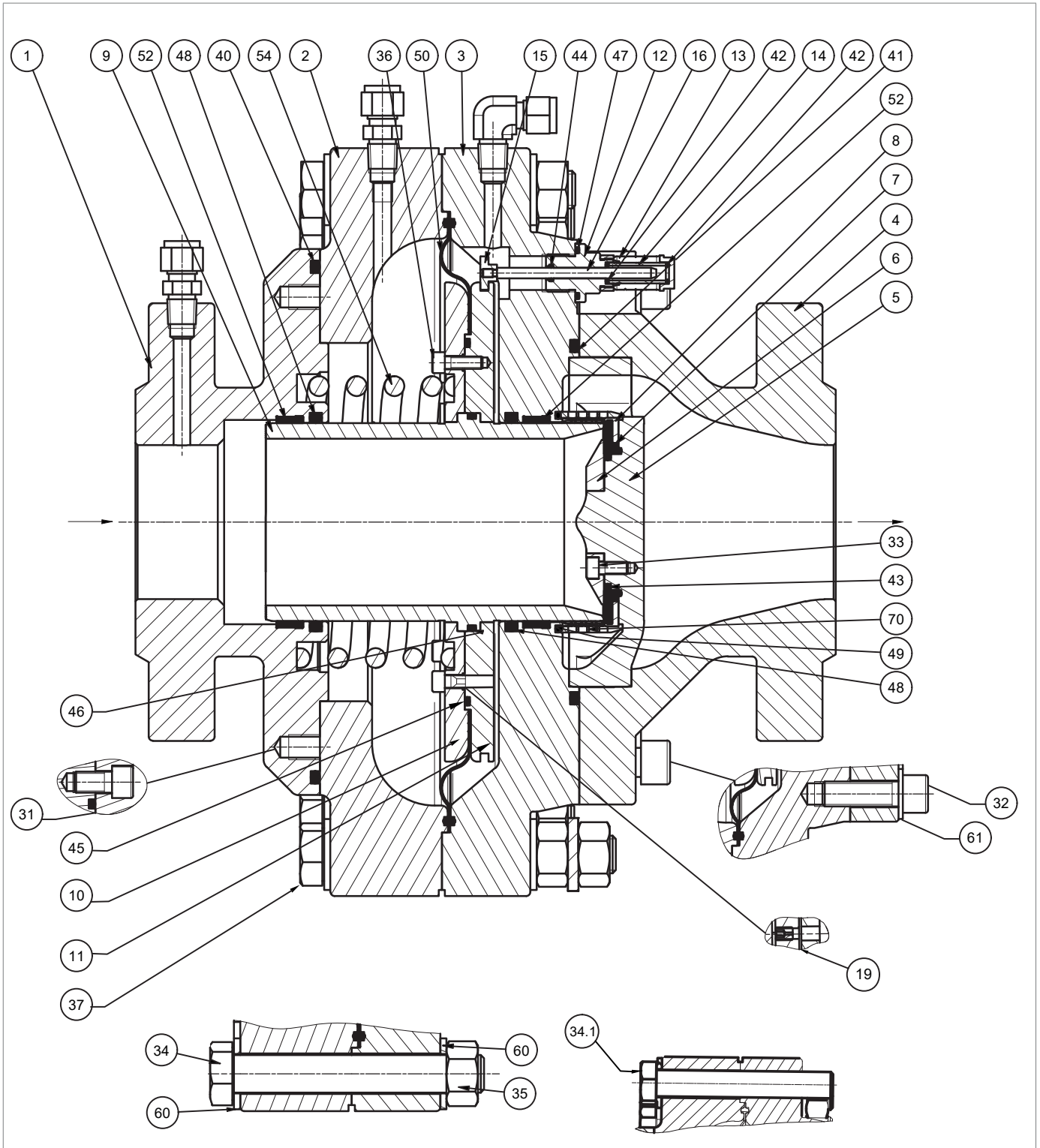

Regulator ASX 176 with silencer LDB/176 2" - 6"

Step	Action
51	Fit the spring (54).
52	Place the upstream cover (2) and the upstream mouthpiece (1) in the plug (9). NOTICE! Take care not to damage the O-ring (48) and the I/DWR (52).
53	Insert and fasten the screws (34.1) in the two threaded holes of the downstream cover (3) to compress the spring (54), and hold the upstream mouthpiece (1) and cover (2) assembly parallel to the downstream cover (3), according to the tightening torque: <ul style="list-style-type: none"> • 2": Tab. 9.71 • 3": Tab. 9.72 • 4": Tab. 9.73 • 6": Tab. 9.74 NOTICE! Take care not to tilt the top cover (2) when fastening the screws (34.1).
54	Place the downstream cover (3) in position with the upstream cover (2).
55	Insert and secure the remaining screws (34) and screw (37) together with the washers (60) with the nut (35) in accordance with the tightening torque: <ul style="list-style-type: none"> • 2": Tab. 9.71 • 3": Tab. 9.72 • 4": Tab. 9.73 • 6": Tab. 9.74 NOTICE! Tighten the screws according to the cross diagram in paragraph 9.4.2.2.
56	Rotate the regulator, resting the downstream mouthpiece (4) on a shockproof surface.
57	Remove and replace the O-rings (42, 44, 47) from the indicator rod guide (12), lubricating them with synthetic grease. NOTICE! Before inserting the replacement O-rings, clean the retaining slots with a cleaning solution.
58	Remove and replace the O-ring (42) from the stroke indicator cap (13), lubricating it with synthetic grease. NOTICE! Before inserting the replacement O-ring, clean the retaining slots with a cleaning solution.
59	Insert the indicator rod assembly (15, 16) into the downstream cover (3).
60	Hook the extension (15) into the right diaphragm holder (11).
61	Insert and screw the indicator rod guide (12) into the downstream cover (3).
62	Insert and secure the stroke indicator cap (13) together with the indicator slide (14) in the indicator rod guide (12).

Tab. 9.93.

NOTICE!

After maintenance, reposition the regulator and spacer (if present) in line following the procedure indicated in paragraph "6.5 - Equipment installation procedure".

WARNING!

Ensure that all parts have been fitted correctly.

9.4.5 - MAINTENANCE PROCEDURE FOR BUILT-IN MONITOR PM/176 OR BUILT-IN SLAM-SHUT VALVE SSX/176

9.4.5.1 - BUILT-IN MONITOR PM/176 OR SSX/176 1"

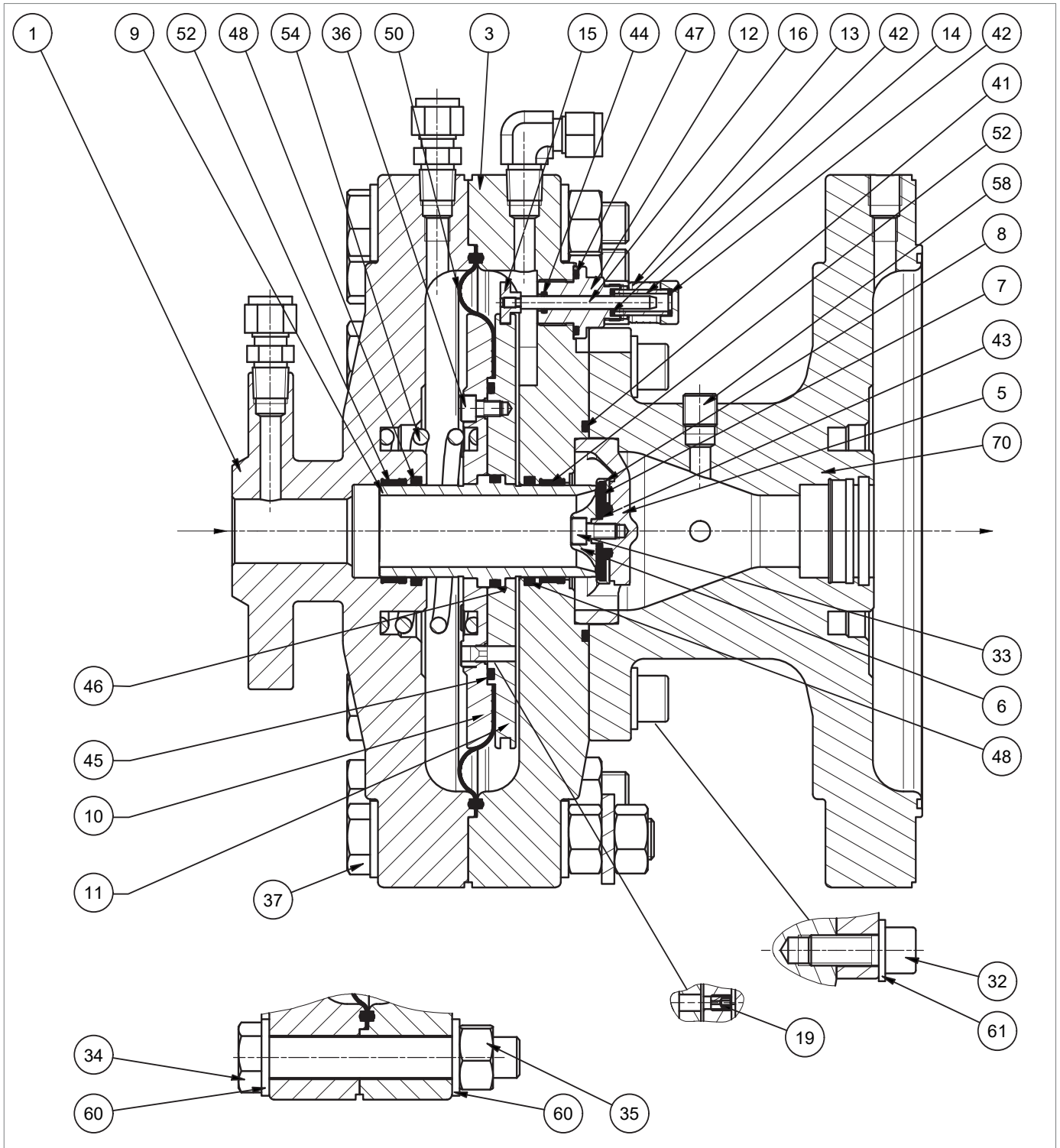







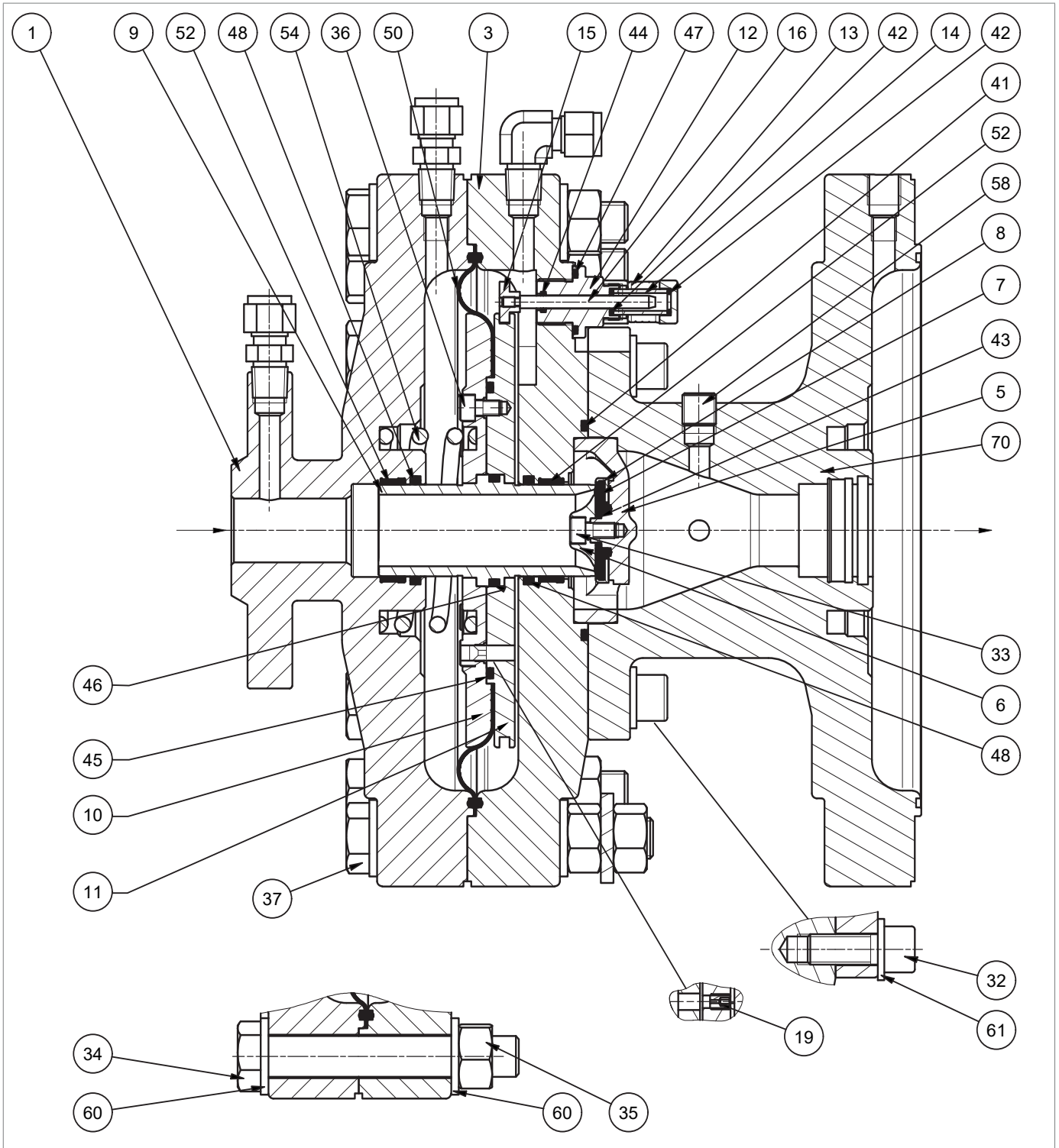









Fig. 9.46. Built-in monitor PM/176 or SSX/176 1"

Step	Action
1	 WARNING! If fitted, remove the spacer.
2	 WARNING! Check that the slam-shut valve is in the shut-off position.
3	Place the regulator with the downstream mouthpiece (4) of the main regulator on a shockproof surface.
4	Unscrew and remove the stroke indicator cap (13) together with the indicator slide (14) from the indicator rod guide (12).
5	Unscrew and remove the indicator rod guide (12) from the downstream cover (3).
6	Remove indicator rod assembly (15, 16) from the downstream cover (3) and diaphragm holder (11).
7	Rotate the regulator, resting the downstream mouthpiece (4) on a shockproof surface.
8	Unscrew and remove the nut (35), together with the screws (34, 37) and washers (60).
9	Undo and remove the screws (34.1) from the downstream cover (3).  NOTICE! The upstream mouthpiece (1) must remain parallel to the downstream cover (3).
10	Remove the spring (54).
11	Remove the diaphragm plug assembly (9, 10, 11, 50) from the downstream cover (3).
12	Position the plug (9) from the downstream side on a shockproof surface.  NOTICE! Take care not to damage the plug (9).
13	Undo and remove the screws (36).  NOTICE! During this phase, prop up the diaphragm holder (11).
14	Remove the diaphragm holder (10) from the plug (9).
15	Remove and replace the diaphragm (50).
16	Remove the O-ring (45) and replace it, lubricating it with synthetic grease.  NOTICE! Before inserting the replacement O-ring, clean the retaining slots with a cleaning solution.
17	Pull the plug (9) out of the diaphragm holder (11).
18	Remove the O-ring (46) and replace it, lubricating it with synthetic grease.  NOTICE! Before inserting the replacement O-ring, clean the retaining slots with a cleaning solution.
19	Place the plug (9) in the diaphragm holder (11).
20	Position the diaphragm (50).
21	Position the diaphragm holder (10).
22	Insert and fix the screws (36) according to the following tightening torque: <ul style="list-style-type: none"> • 1": Tab. 9.75  NOTICE! Tighten the screws according to the cross diagram in paragraph 9.4.2.2.







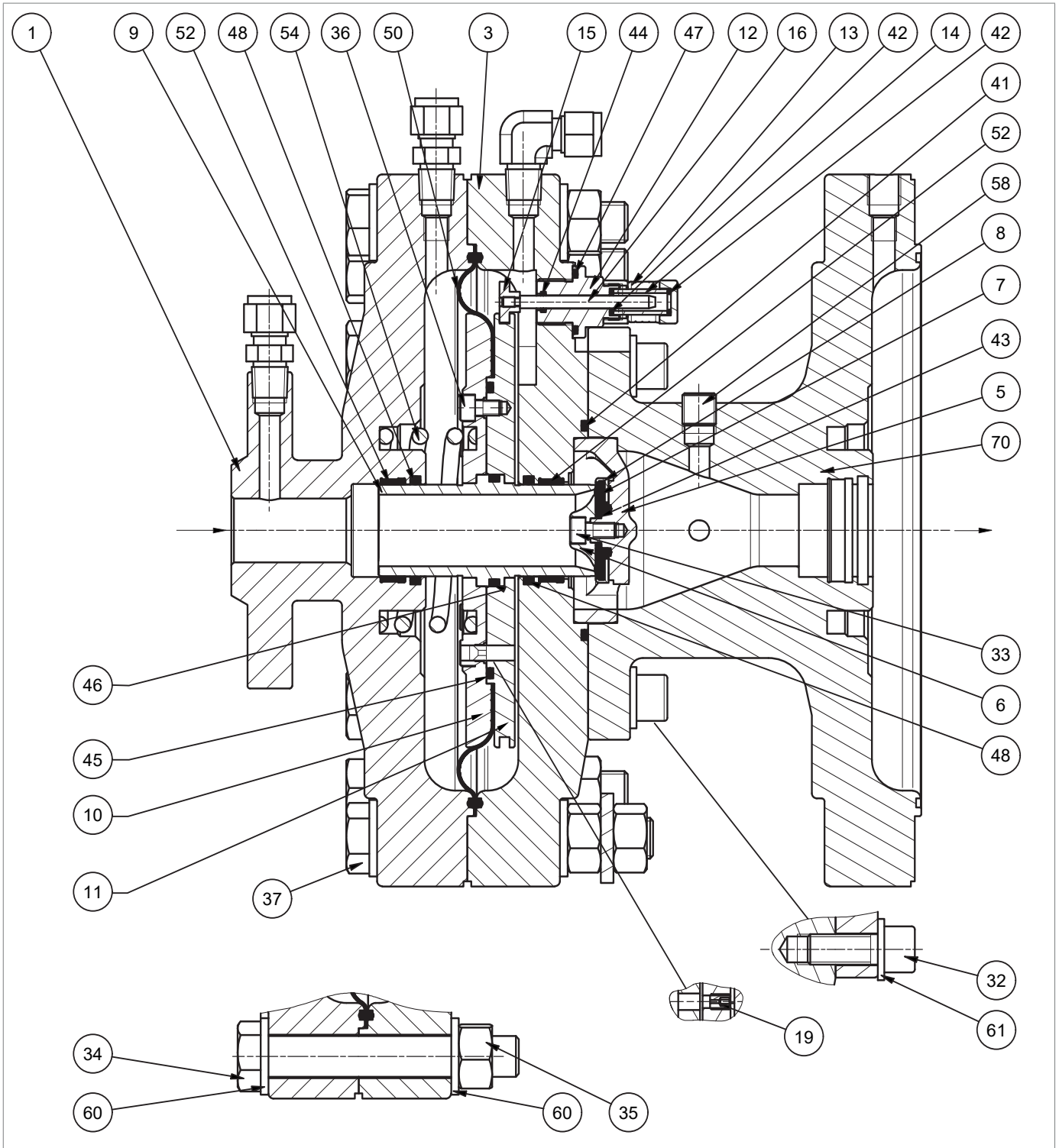



Built-in monitor PM/176 or SSX/176 1"

Step	Action
23	<p>VALID ONLY FOR PM/176 1" Check the hole in the transfer (19) on the diaphragm holder (10).</p> <p> WARNING! Make sure it is not obstructed.</p>
24	<p>Remove and replace the O-ring (48) from the upstream mouthpiece (1), lubricating it with synthetic grease.</p> <p> NOTICE! Before inserting the replacement O-ring, clean the retaining slots with a cleaning solution.</p>
25	<p>Remove and replace the I/DWR ring (52) from the upstream mouthpiece (1).</p> <p> NOTICE! Before inserting the replacement I/DWR ring, clean the retaining slots with a cleaning solution.</p>
26	<p>Remove and replace the O-ring (48) from the downstream cover (3), lubricating it with synthetic grease.</p> <p> NOTICE! Before inserting the replacement O-ring, clean the retaining slots with a cleaning solution.</p>
27	<p>Remove and replace the I/DWR ring (52) from the downstream cover (3).</p> <p> NOTICE! Before inserting the replacement I/DWR ring, clean the retaining slots with a cleaning solution.</p>
28	Turn the downstream cover assembly (3) and the downstream mouthpiece (4) upside down, placing the downstream cover on an impact-resistant surface.
29	Undo the screws (32) together with the washers (61).
30	Remove the mouthpiece (70).
31	Remove the reinforced gasket assembly (4, 5, 6, 7, 8, 33, 43) from the mouthpiece (70).
32	Unscrew and remove the screw (33) together with the shaft collar (6) from the reinforced gasket assembly.
33	Remove gasket ring holder (8), gasket ring (7) and O-ring (43) from the gasket holder (5).
34	<p>Replace the O-ring (43), lubricating it with synthetic grease.</p> <p> NOTICE! Before inserting the replacement O-ring, clean the retaining slots with a cleaning solution.</p>
35	Remove and replace the gasket ring (7) from the gasket ring holder (8).
36	Position the gasket ring support (8) and gasket ring (7) in the reinforced gasket assembly.
37	<p>Insert and fasten the screw (33) together with the shaft collar (6) according to the tightening torque:</p> <ul style="list-style-type: none"> • 1": Tab. 9.75 <p> NOTICE! Tighten the screws according to the cross diagram in paragraph 9.4.2.2.</p>



Built-in monitor PM/176 or SSX/176 1"

Step	Action
38	Remove the O-ring (41) and replace it, lubricating it with synthetic grease.  NOTICE! Before inserting the replacement O-ring, clean the retaining slots with a cleaning solution.
39	Place the reinforced gasket assembly (4, 5, 6, 7, 8, 33, 43) in the mouthpiece (70).
40	Place the downstream cover (3) in the mouthpiece (70).
41	Insert and fasten the screws (32) together with the washers (61) according to the tightening torque: <ul style="list-style-type: none"> • 1": Tab. 9.75  NOTICE! Tighten the screws according to the cross diagram in paragraph 9.4.2.2.
42	Turn the downstream cover assembly (3) and the downstream mouthpiece (4) upside down, placing the mouthpiece on an impact-resistant surface.
43	Insert the diaphragm plug assembly (9, 10, 11, 50) into the downstream cover (3).  NOTICE! Take care not to damage the O-ring (48), the I/DWR (52) and the plug profile (9).
44	Fit the spring (54).
45	Place the downstream cover (3) and the upstream mouthpiece (1) in the plug (9).  NOTICE! Take care not to damage the O-ring (48) and the I/DWR (52).
46	Insert and fasten the screws (34.1) in the two threaded holes of the downstream cover (3) to compress the spring (54) and hold the upstream mouthpiece (1) parallel to the downstream cover (3), according to the tightening torque: <ul style="list-style-type: none"> • 1": Tab. 9.75  NOTICE! Take care not to tilt the upstream mouthpiece (1) when tightening the screws (34.1).
47	Place the downstream cover (3) with the upstream mouthpiece (1) in position.
48	Insert and secure the remaining screws (34) and screw (37) together with the washers (60) with the nut (35) in accordance with the tightening torque: <ul style="list-style-type: none"> • 1": Tab. 9.75  NOTICE! Tighten the screws according to the cross diagram in paragraph 9.4.2.2.
49	Rotate the regulator, resting the downstream mouthpiece (4) on a shockproof surface.
50	Remove and replace the O-rings (42, 44, 47) from the indicator rod guide (12), lubricating them with synthetic grease.  NOTICE! Before inserting the replacement O-rings, clean the retaining slots with a cleaning solution.
51	Remove and replace the O-ring (42) from the downstream cover (3), lubricating it with synthetic grease.  NOTICE! Before inserting the replacement O-ring, clean the retaining slots with a cleaning solution.

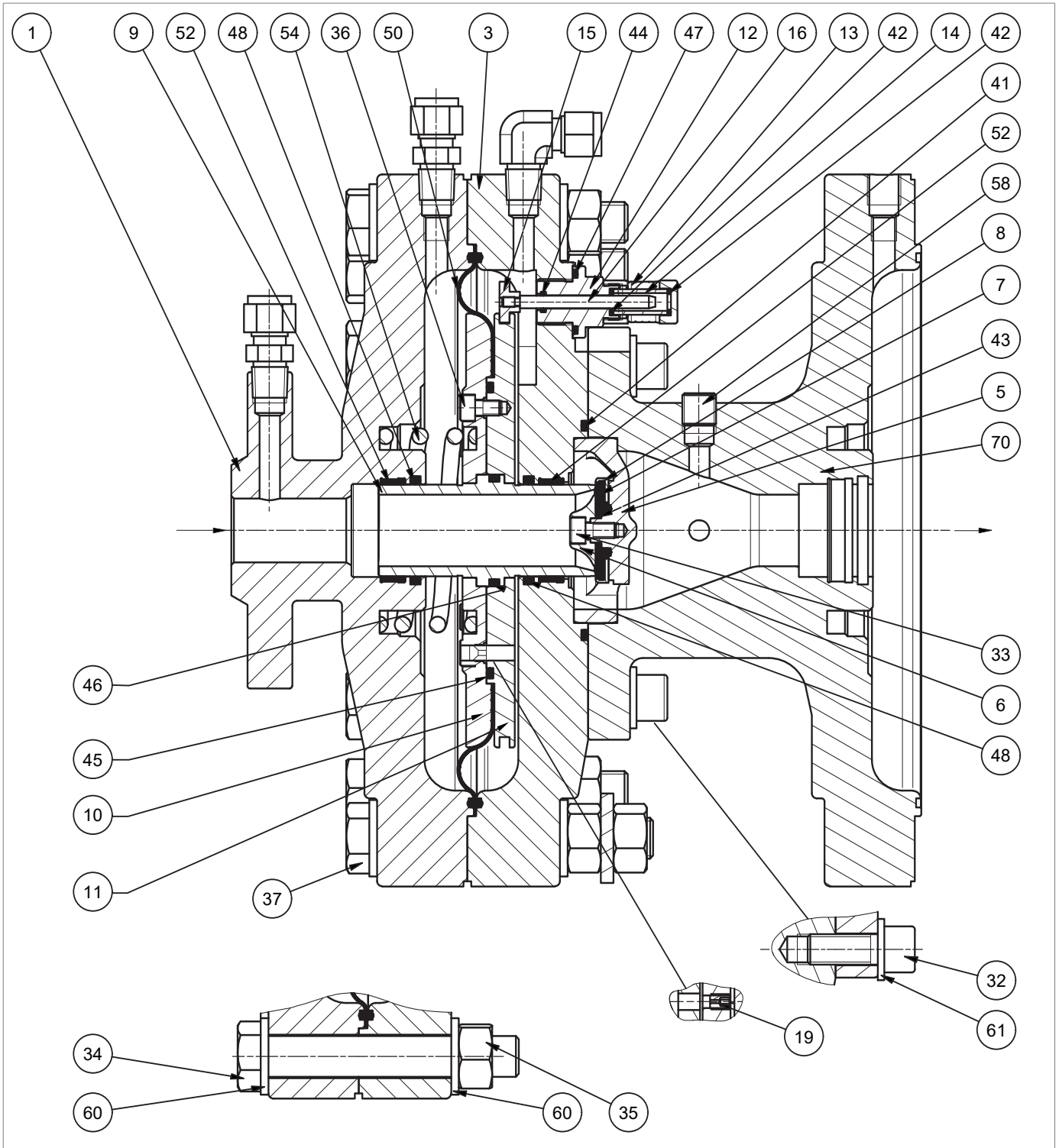

Built-in monitor PM/176 or SSX/176 1"

Step	Action
52	Insert the indicator rod assembly (12) into the downstream cover (3).
53	Hook the extension (15) into the left diaphragm holder (10).
54	Insert and screw the indicator rod guide (12) into the downstream cover (3).
55	Insert and secure the stroke indicator cap (13) together with the indicator slide (14) in the indicator rod guide (12).

Tab. 9.94.

 **NOTICE!**

After maintenance, reposition the regulator and spacer (if present) in line following the procedure indicated in paragraph "6.5 - Equipment installation procedure".

 **WARNING!**

Ensure that all parts have been fitted correctly.

9.4.5.2 - BUILT-IN MONITOR PM/176 OR SSX/176 2" - 6"

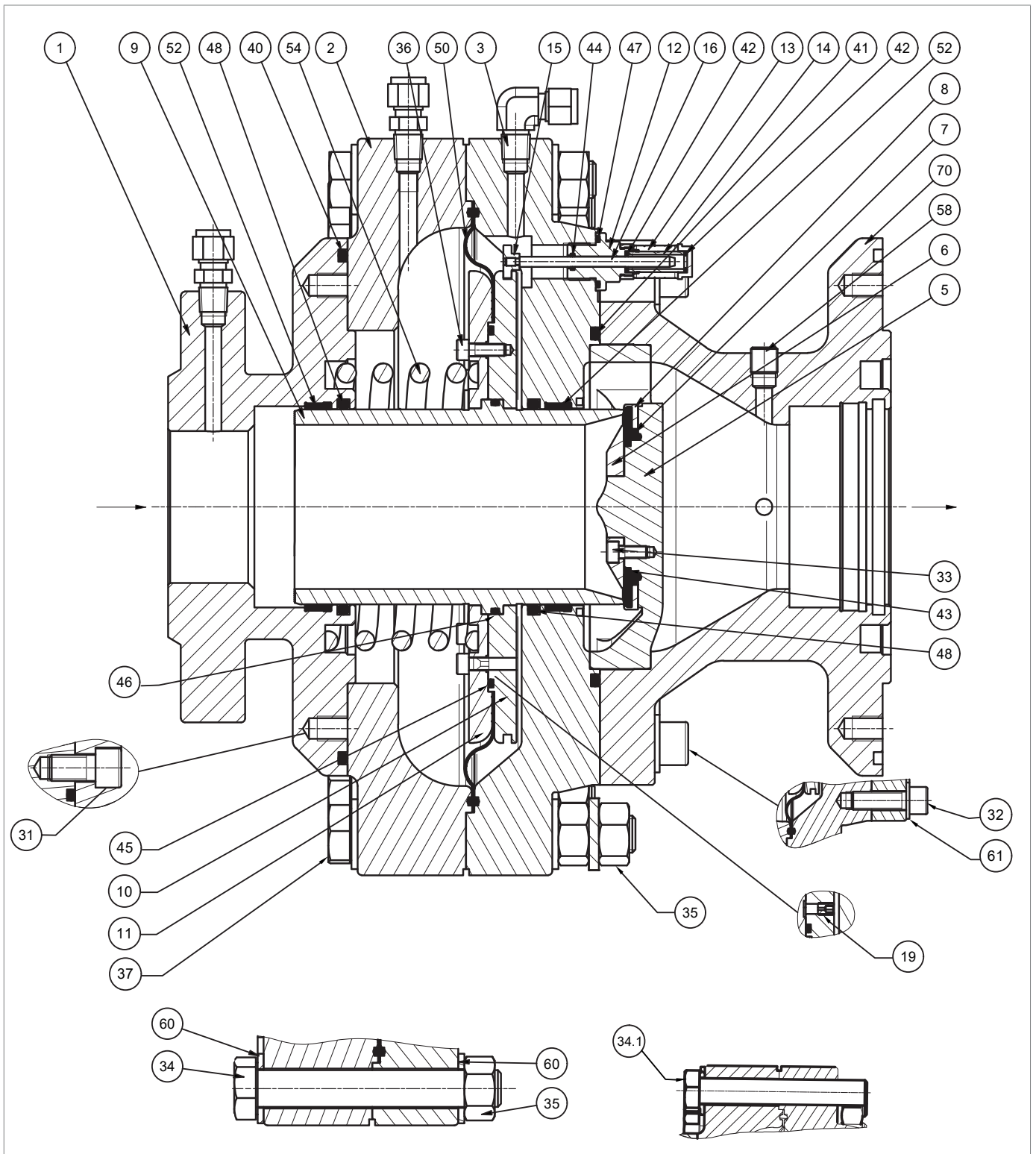







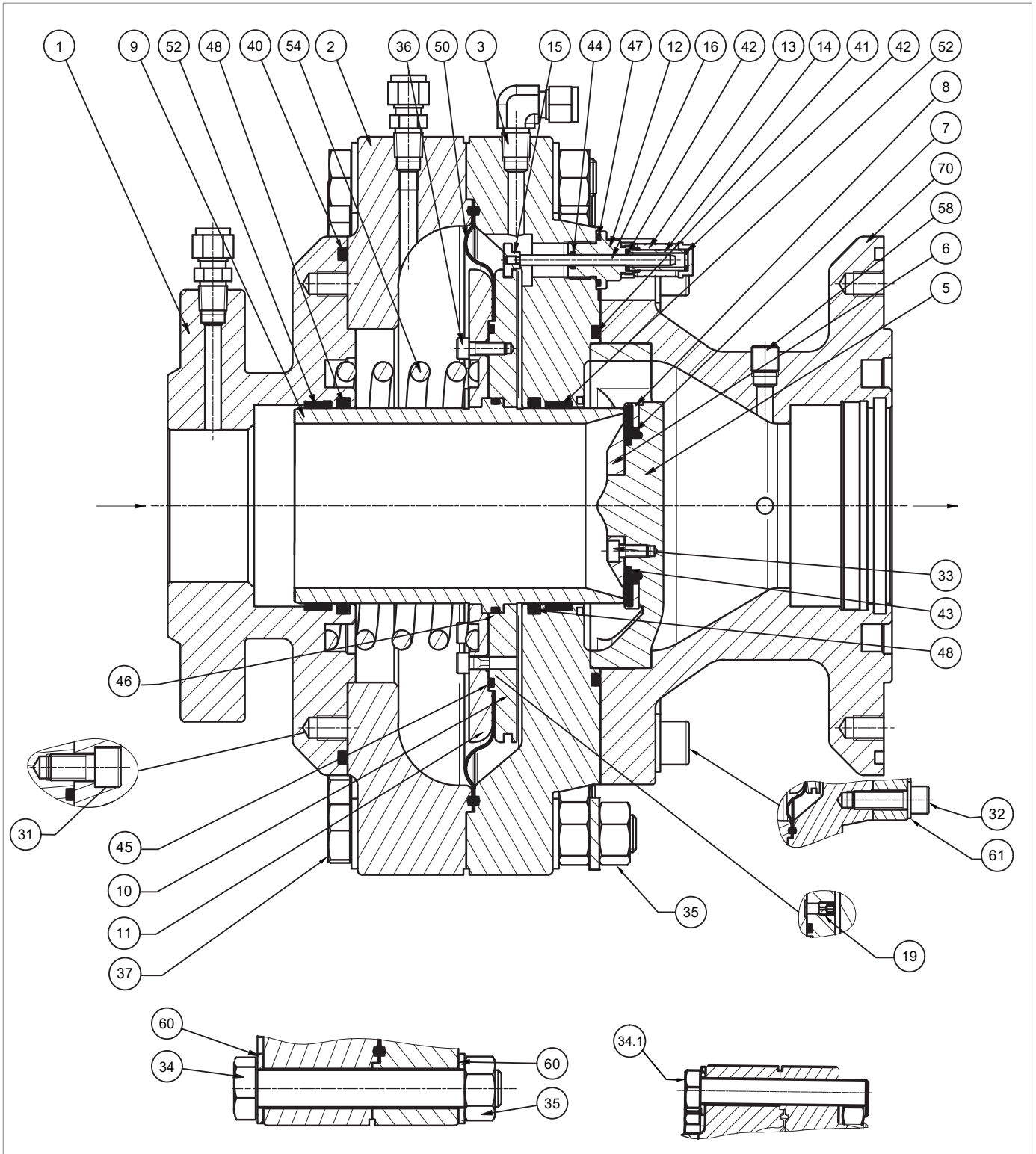









Fig. 9.47. Built-in monitor PM/176 or SSX/176 2" - 6"

Step	Action
1	 WARNING! If fitted, remove the spacer.
2	 WARNING! Check that the slam-shut valve is in the shut-off position.
3	Place the regulator with the downstream mouthpiece (4) of the main regulator on a shockproof surface.
4	Unscrew and remove the stroke indicator cap (13) together with the indicator slide (14) from the indicator rod guide (12).
5	Unscrew and remove the indicator rod guide (12) from the downstream cover (3).
6	Remove indicator rod assembly (15, 16) from the downstream cover (3) and right diaphragm holder (11).
7	Rotate the regulator, resting the downstream mouthpiece (4) on a shockproof surface.
8	Unscrew and remove the nut (35), together with the screws (34, 37) and washers (60).
9	Undo and remove the screws (34.1) from the downstream cover (3).  NOTICE! The upstream mouthpiece (1) and cover (2) assembly must remain parallel to the downstream cover (3).
10	Separate the upstream cover (2) from the downstream cover (3).  NOTICE! Place the upstream cover (2) on the side of the upstream mouthpiece (1).
11	Remove the spring (54).
12	Remove the diaphragm plug assembly (9, 10, 11, 50) from the downstream cover (3).
13	Position the plug (9) from the downstream side on a shockproof surface.  NOTICE! Take care not to damage the plug (9).
14	Undo and remove the screws (36).  NOTICE! During this phase, prop up the diaphragm holder (11).
15	Remove the diaphragm holder (10) from the plug (9).
16	Remove and replace the diaphragm (50).
17	Remove the O-ring (45) and replace it, lubricating it with synthetic grease.  NOTICE! Before inserting the replacement O-ring, clean the retaining slots with a cleaning solution.
18	Pull the plug (9) out of the diaphragm holder (11).
19	Remove the O-ring (46) and replace it, lubricating it with synthetic grease.  NOTICE! Before inserting the replacement O-ring, clean the retaining slots with a cleaning solution.
20	Place the plug (9) in the diaphragm holder (11).
21	Position the diaphragm (50).
22	Position the diaphragm holder (10).







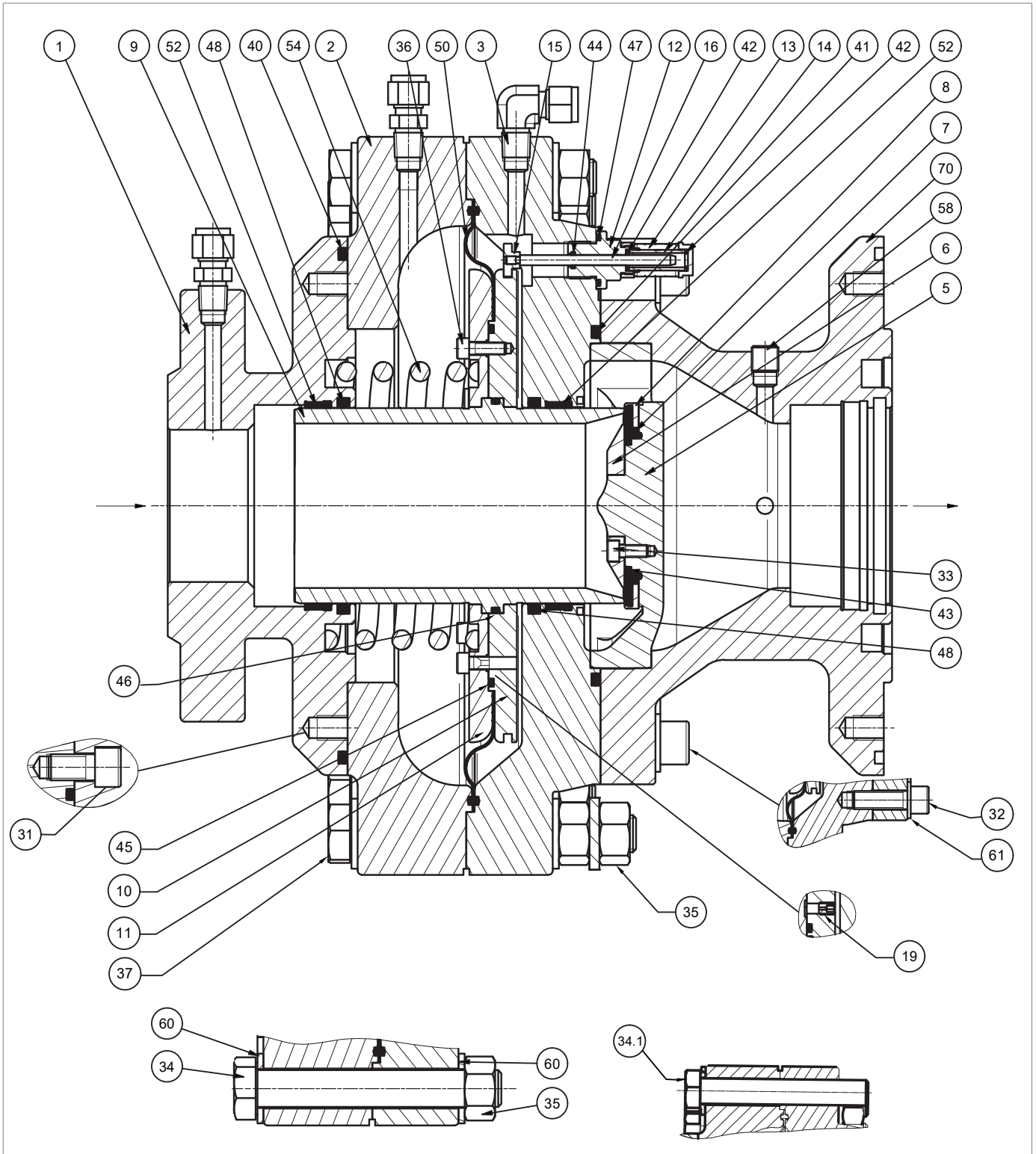

Built-in monitor PM/176 DN or SSX/176 2" - 6"

Step	Action
23	<p>Insert and fix the screws (36) according to the following tightening torque:</p> <ul style="list-style-type: none"> • 2": Tab. 9.76 • 3": Tab. 9.77 • 4": Tab. 9.78 • 6": Tab. 9.79 <div style="border: 1px solid black; padding: 5px;">  NOTICE! Tighten the screws according to the cross diagram in paragraph 9.4.2.2. </div>
24	<p>ONLY VALID FOR PM/176 2" - 6" Check the hole in the transfer (19) on the left diaphragm holder (10).</p> <div style="background-color: #f4a460; padding: 5px;">  WARNING! Make sure it is not obstructed. </div>
25	Undo and remove the screws (31).
26	Separate the upstream cover (2) from the upstream mouthpiece (1).
27	<p>Remove and replace the O-rings (40, 48) from the upstream mouthpiece (1), lubricating them with synthetic grease.</p> <div style="border: 1px solid black; padding: 5px;">  NOTICE! Before inserting the replacement O-rings, clean the retaining slots with a cleaning solution. </div>
28	<p>Remove and replace the I/DWR ring (52) from the upstream mouthpiece (1).</p> <div style="border: 1px solid black; padding: 5px;">  NOTICE! Before inserting the replacement I/DWR ring, clean the retaining slots with a cleaning solution. </div>
29	Place upstream cover (2) in upstream mouthpiece (1).
30	<p>Insert and fix the screws (31) according to the following tightening torque:</p> <ul style="list-style-type: none"> • 2": Tab. 9.76 • 3": Tab. 9.77 • 4": Tab. 9.78 • 6": Tab. 9.79 <div style="border: 1px solid black; padding: 5px;">  NOTICE! Tighten the screws according to the cross diagram in paragraph 9.4.2.2. </div>
31	<p>Remove and replace the O-ring (48) from the downstream cover (3), lubricating it with synthetic grease.</p> <div style="border: 1px solid black; padding: 5px;">  NOTICE! Before inserting the replacement O-ring, clean the retaining slots with a cleaning solution. </div>
32	<p>Remove and replace the I/DWR ring (52) from the downstream cover (3).</p> <div style="border: 1px solid black; padding: 5px;">  NOTICE! Before inserting the replacement I/DWR ring, clean the retaining slots with a cleaning solution. </div>
33	Turn the downstream cover assembly (3) and downstream mouthpiece (4) upside down, placing the downstream cover on an impact-resistant surface



Built-in monitor PM/176 DN or SSX/176 2" - 6"

Step	Action
34	Undo the screws (32) together with the washers (61).
35	Remove the downstream mouthpiece (70).
36	Remove the reinforced gasket assembly (4, 5, 6, 7, 8, 33, 43) from the mouthpiece (70).
37	Unscrew and remove the screws (33) together with the shaft collar (6) from the gasket support (5).
38	Remove gasket ring holder (8), gasket ring (7) and O-ring (43) from the gasket holder (5).
39	Replace the O-ring (43), lubricating it with synthetic grease. <div style="border: 1px solid black; padding: 5px;">  NOTICE! Before inserting the replacement O-ring, clean the retaining slots with a cleaning solution. </div>
40	Remove and replace the gasket ring (7) from the gasket ring holder (8).
41	Place the gasket ring holder (8) and the gasket ring (7) in the gasket holder (5).
42	Insert and fasten the screws (33) together with the shaft collar (6) according to the tightening torque: <ul style="list-style-type: none"> • 2": Tab. 9.76 • 3": Tab. 9.77 • 4": Tab. 9.78 • 6": Tab. 9.79 <div style="border: 1px solid black; padding: 5px;">  NOTICE! Tighten the screws according to the cross diagram in paragraph 9.4.2.2. </div>
43	Remove and replace the O-ring (41) from the downstream cover (3), lubricating it with synthetic grease. <div style="border: 1px solid black; padding: 5px;">  NOTICE! Before inserting the replacement O-ring, clean the retaining slots with a cleaning solution. </div>
44	Place the reinforced gasket assembly (4, 5, 6, 7, 8, 33, 43) in the mouthpiece (70).
45	Place the downstream cover (3) in the mouthpiece (70).
46	Insert and fasten the screws (32) together with the washers (61) according to the tightening torque: <ul style="list-style-type: none"> • 2": Tab. 9.76 • 3": Tab. 9.77 • 4": Tab. 9.78 • 6": Tab. 9.79 <div style="border: 1px solid black; padding: 5px;">  NOTICE! Tighten the screws according to the cross diagram in paragraph 9.4.2.2. </div>
47	Insert the diaphragm plug assembly (9, 10, 11, 50) into the downstream cover (3). <div style="border: 1px solid black; padding: 5px;">  NOTICE! Take care not to damage the O-ring (48), the I/DWR (52) and the plug profile (9). </div>
48	Fit the spring (54).
49	Place the upstream cover (2) and the upstream mouthpiece (1) in the plug (9). <div style="border: 1px solid black; padding: 5px;">  NOTICE! Take care not to damage the O-ring (48) and the I/DWR (52). </div>

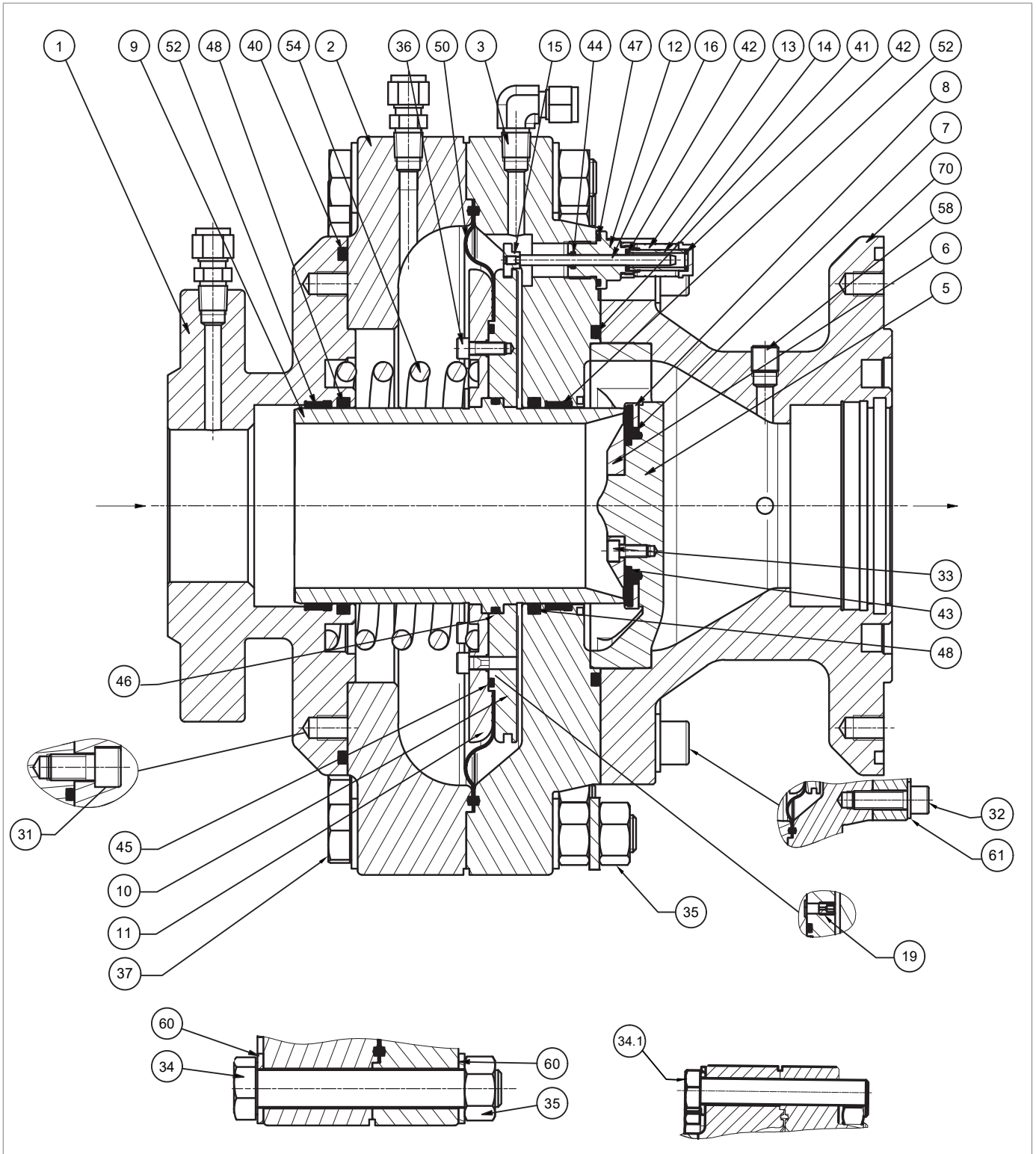

Built-in monitor PM/176 DN or SSX/176 2" - 6"

Step	Action
50	<p>Insert and fasten the screws (34.1) in the two threaded holes of the downstream cover (3) to compress the spring (54), and hold the upstream mouthpiece (1) and upstream cover (2) assembly parallel to the downstream cover (3), according to the tightening torque:</p> <ul style="list-style-type: none"> • 2": Tab. 9.76 • 3": Tab. 9.77 • 4": Tab. 9.78 • 6": Tab. 9.79 <div style="border: 1px solid black; padding: 5px;"> <p>! NOTICE!</p> <p>Take care not to tilt the top cover (2) when fastening the screws (34.1).</p> </div>
51	<p>Place the downstream cover (3) in position with the upstream cover (2).</p> <div style="border: 1px solid black; padding: 5px;"> <p>! NOTICE!</p> <p>Ensure that the diaphragm lanyard (50) remains in place.</p> </div>
52	<p>Insert and fasten the remaining screws (34) and screw (37) together with the washers (60) according to the tightening torque:</p> <ul style="list-style-type: none"> • 2": Tab. 9.76 • 3": Tab. 9.77 • 4": Tab. 9.78 • 6": Tab. 9.79 <div style="border: 1px solid black; padding: 5px;"> <p>! NOTICE!</p> <p>Tighten the screws according to the cross diagram in paragraph 9.4.2.2.</p> </div>
53	<p>Rotate the regulator, resting the downstream mouthpiece (4) on a shockproof surface.</p>
54	<p>Remove and replace the O-rings (42, 44, 47) from the indicator rod guide (12), lubricating them with synthetic grease.</p> <div style="border: 1px solid black; padding: 5px;"> <p>! NOTICE!</p> <p>Before inserting the replacement O-rings, clean the retaining slots with a cleaning solution.</p> </div>
55	<p>Remove and replace the O-ring (42) from the stroke indicator cap (13), lubricating it with synthetic grease.</p> <div style="border: 1px solid black; padding: 5px;"> <p>! NOTICE!</p> <p>Before inserting the replacement O-ring, clean the retaining slots with a cleaning solution.</p> </div>
56	<p>Insert the indicator rod assembly (15, 16) into the downstream cover (3).</p>
57	<p>Hook the extension (15) into the diaphragm holder (11).</p>
58	<p>Insert and screw the indicator rod guide (12) into the downstream cover (3).</p>
59	<p>Insert and secure the stroke indicator cap (13) together with the indicator slide (14) in the indicator rod guide (12).</p>

Tab. 9.95.

! NOTICE!

After maintenance, reposition the regulator and spacer (if present) in line following the procedure indicated in paragraph 6.5 'Installation procedure'.

! WARNING!

Ensure that all parts have been fitted correctly.

9.4.6 - PILOT MAINTENANCE PROCEDURE 200/A SERIES + PRE-REGULATOR R14/A

9.4.6.1 - 200/A SERIES PILOT DISCONNECTION

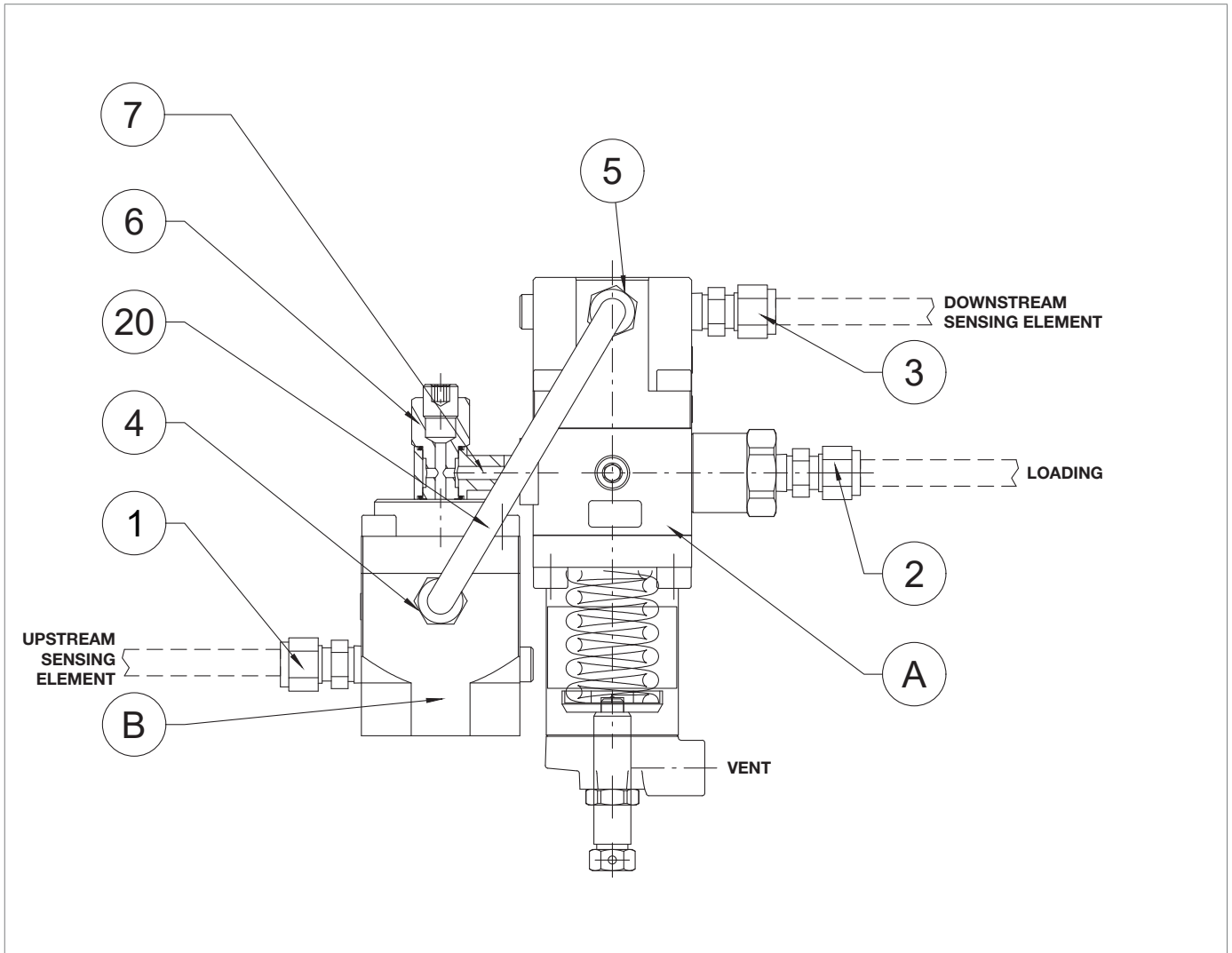

Fig. 9.48. 200/A series pilot

To disconnect the pilot, proceed as in Tab. 9.96:

Step	Action
1	Disconnect the sensing lines between the 200/A pilot and the regulator by adjusting the fittings (1, 2, 3).
2	Unscrew and remove the fixing screw to remove the pilot from the regulator.
3	Remove the pipe (20) by adjusting the fittings (4, 5).
4	Unscrew and remove the screw (6) to separate the R14/A pre-regulator from the pilot.
5	Undo and remove the screw (7) from pilot 200/A.

Tab. 9.96.

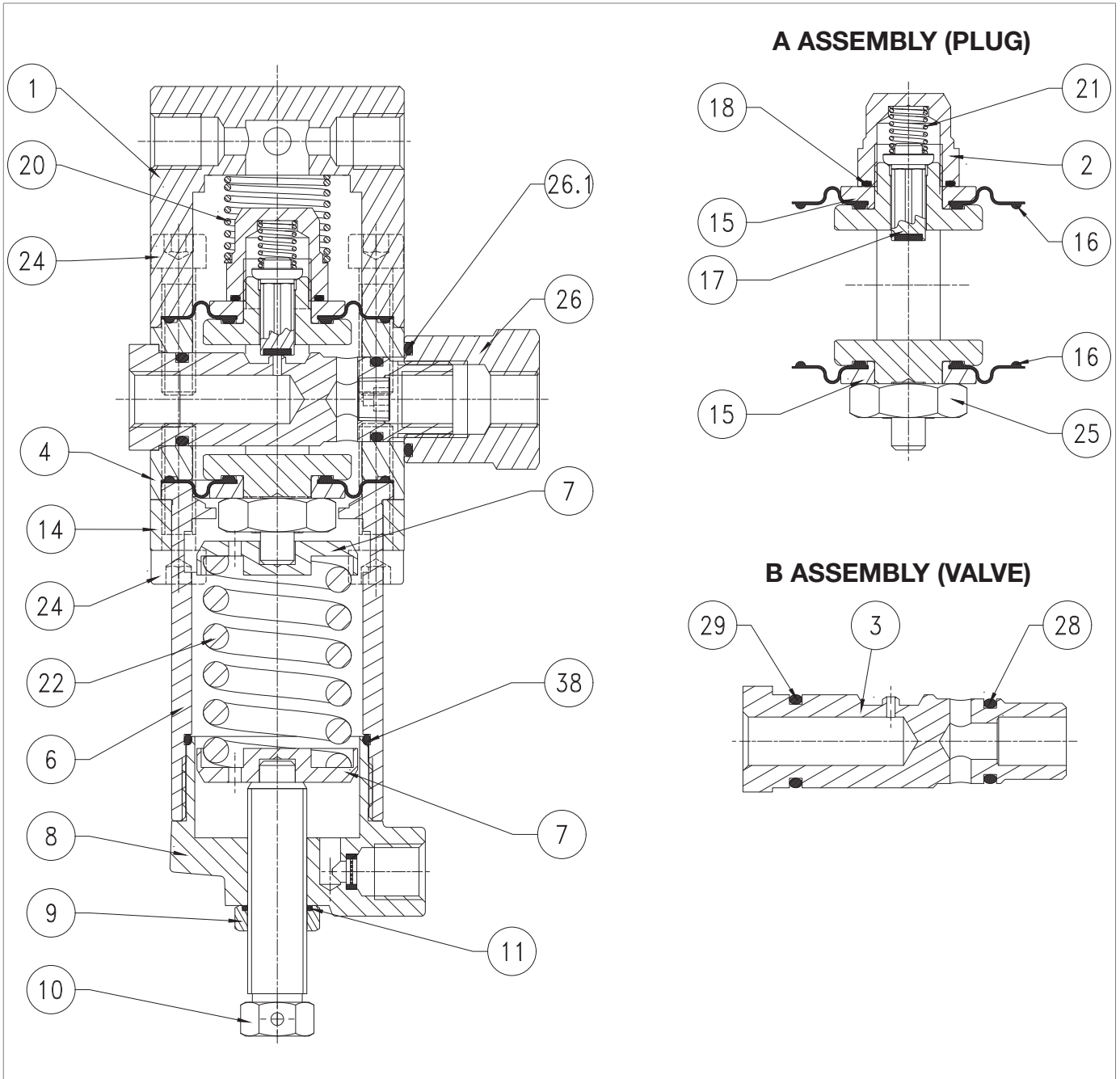



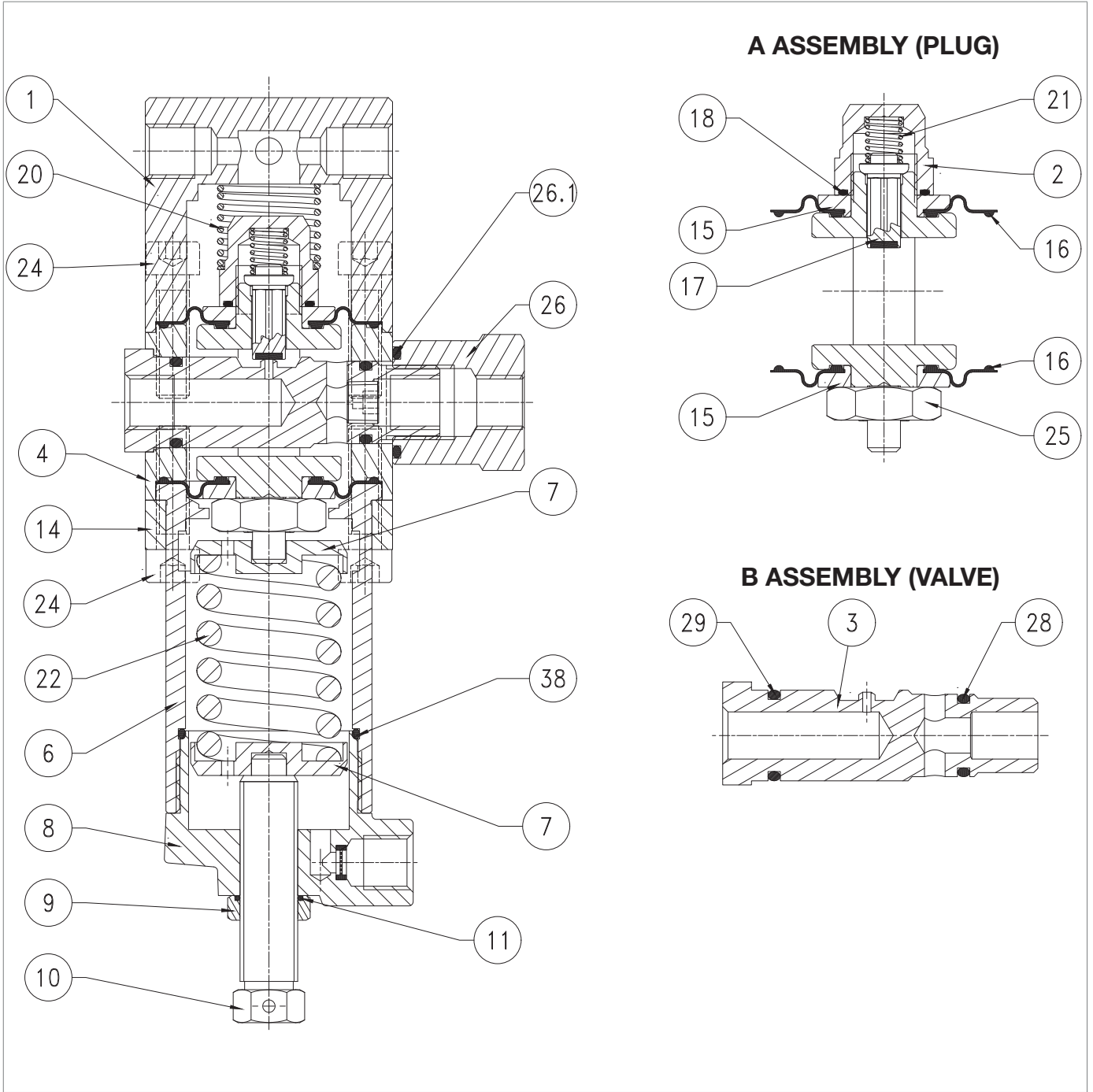

Fig. 9.49. Pilot 204/A - 205/A

Step	Action
1	Loosen the nut (9).
2	Completely release the spring (22) by turning the adjusting screw (10).
3	Remove the adjusting screw (10) together with the cap (9).
4	Remove the cap (8).
	Remove the O-ring (38) from the cap (8) and replace it, lubricating it with synthetic grease.
5	 NOTICE! Before inserting the replacement O-ring, clean the retaining slots with a cleaning solution.
6	Remove the spring (22) and the spring supports (7).
7	Undo and remove the screws of the lower section (24).
8	Remove the bracket (14) from the sleeve (6).
9	Remove the sleeve (6).
10	Undo and remove the screws of the upper section (24).
11	Remove the pilot cover (1).
12	Remove the spring (20).
13	Unscrew and remove the nut (26).
	Remove the O-ring (26.1) from the nut (26) and replace it, lubricating it with synthetic grease.
14	 NOTICE! Before inserting the replacement O-ring, clean the retaining slots with a cleaning solution.
15	Pull out the "B" (valve) assembly.
	Remove the O-rings (28, 29) from the valve seat (3) and replace them, lubricating them with synthetic grease.
16	 NOTICE! Before inserting the replacement O-ring, clean the retaining slots with a cleaning solution.
17	Remove assembly "A" (plug) from the valve body (4) by pushing it from the top downwards.
18	Unscrew and remove the pilot nut (2).
	Remove the O-ring (18) of the pilot nut (2) and replace it, lubricating it with synthetic grease.
19	 NOTICE! Before inserting the replacement O-ring, clean the retaining slots with a cleaning solution.
20	Remove the spring (21).
21	Remove and replace the plug (17).
22	Remove the upper protection disc (15).
	Remove and replace the upper diaphragm (16), lubricating the lanyards with synthetic grease.
23	 NOTICE! Before inserting the replacement diaphragm, clean the retaining slots with a cleaning solution.
24	Unscrew and remove the nut (25).
25	Remove the lower protection disc (15).



Pilot 204/A - 205/A

Step	Action
26	Remove and replace the lower diaphragm (16), lubricating the lanyards with synthetic grease. NOTICE! Before inserting the replacement diaphragm, clean the retaining slots with a cleaning solution.
27	Fit the lower protection disc (15).
28	Fix the nut (25) according to the following tightening torque: • Pilot 204/A-205/A: Tab. 9.80
29	Fit the plug (17) and then the spring (21).
30	Fit the upper protection disc (15).
31	Fix the pilot nut (2) according to the following tightening torque: • Pilot 204/A-205/A: Tab. 9.80
32	Insert assembly "A" (plug) from top to bottom into the valve body (4). NOTICE! • Take care not to damage the diaphragms (16) during this step • Make sure the marking on the lower section of the headframe is parallel to the axis of the hole for inserting the seat (3) into the valve body (4).
33	Insert assembly "B" (valve) into the valve body (4). NOTICE! Take care not to damage the O-rings (28, 29) and the valve seat (3).
34	Screw in the nut (26) according to the following tightening torque: • Pilot 204/A-205/A: Tab. 9.80
35	Fit the spring (20).
36	Fit the cover (1).
37	Insert and fix the screws of the upper section (24) according to the following tightening torque: • Pilot 204/A-205/A: Tab. 9.80
38	Fit the sleeve (6) and the bracket (14).
39	Insert and fix the screws of the lower section (24) according to the following tightening torque: • Pilot 204/A-205/A: Tab. 9.80
40	Fit the spring (22) and the spring supports (7).
41	Unscrew the cap (8).
42	Remove and replace the O-ring (11) in the nut (9). NOTICE! Before inserting the replacement O-ring, clean the retaining slots with a cleaning solution.
43	Fit the adjusting screw (10) together with the cap (9).

Tab. 9.97.

WARNING!

Ensure that all parts have been fitted correctly.

9.4.6.3 - PILOT 207/A

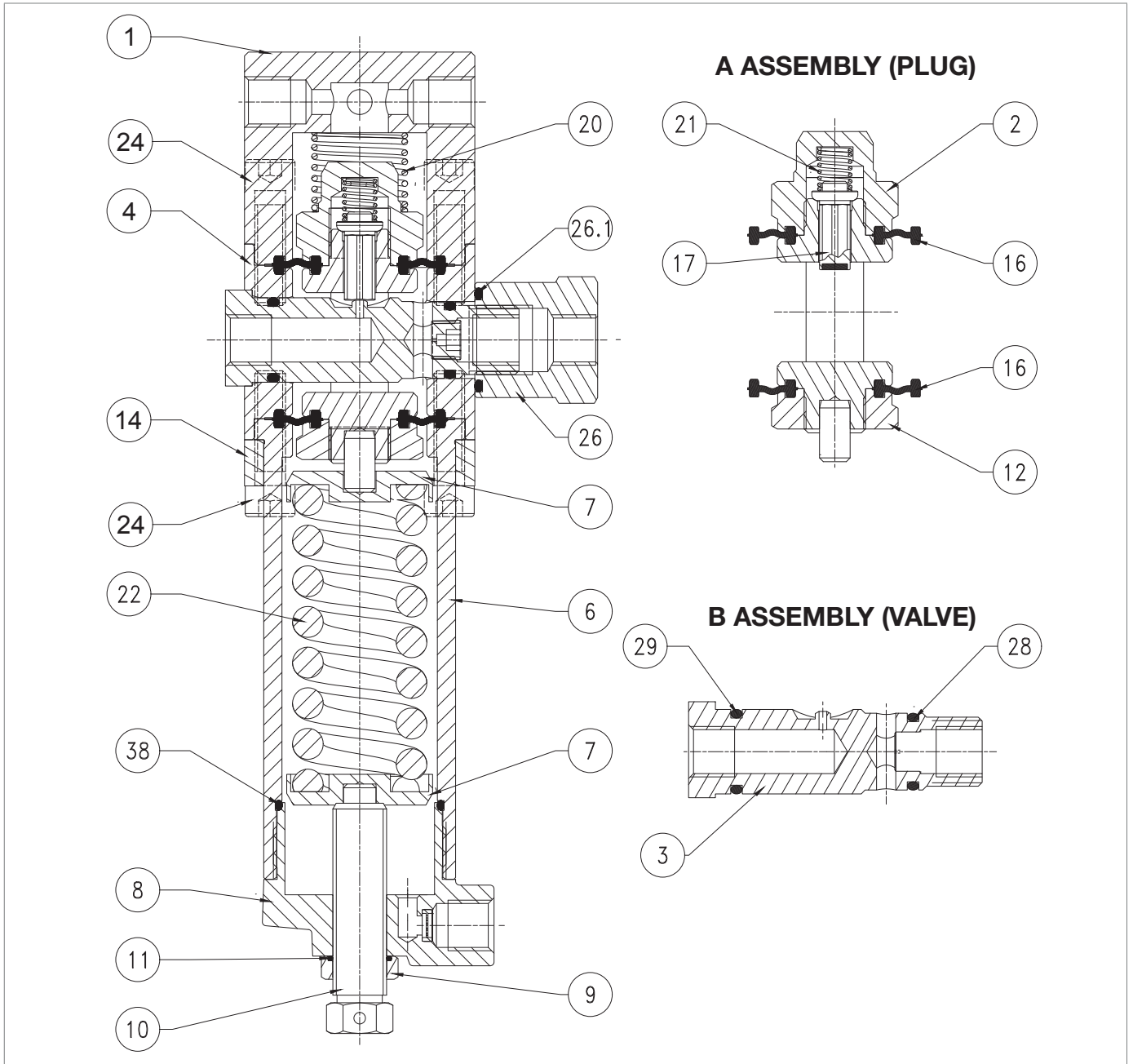



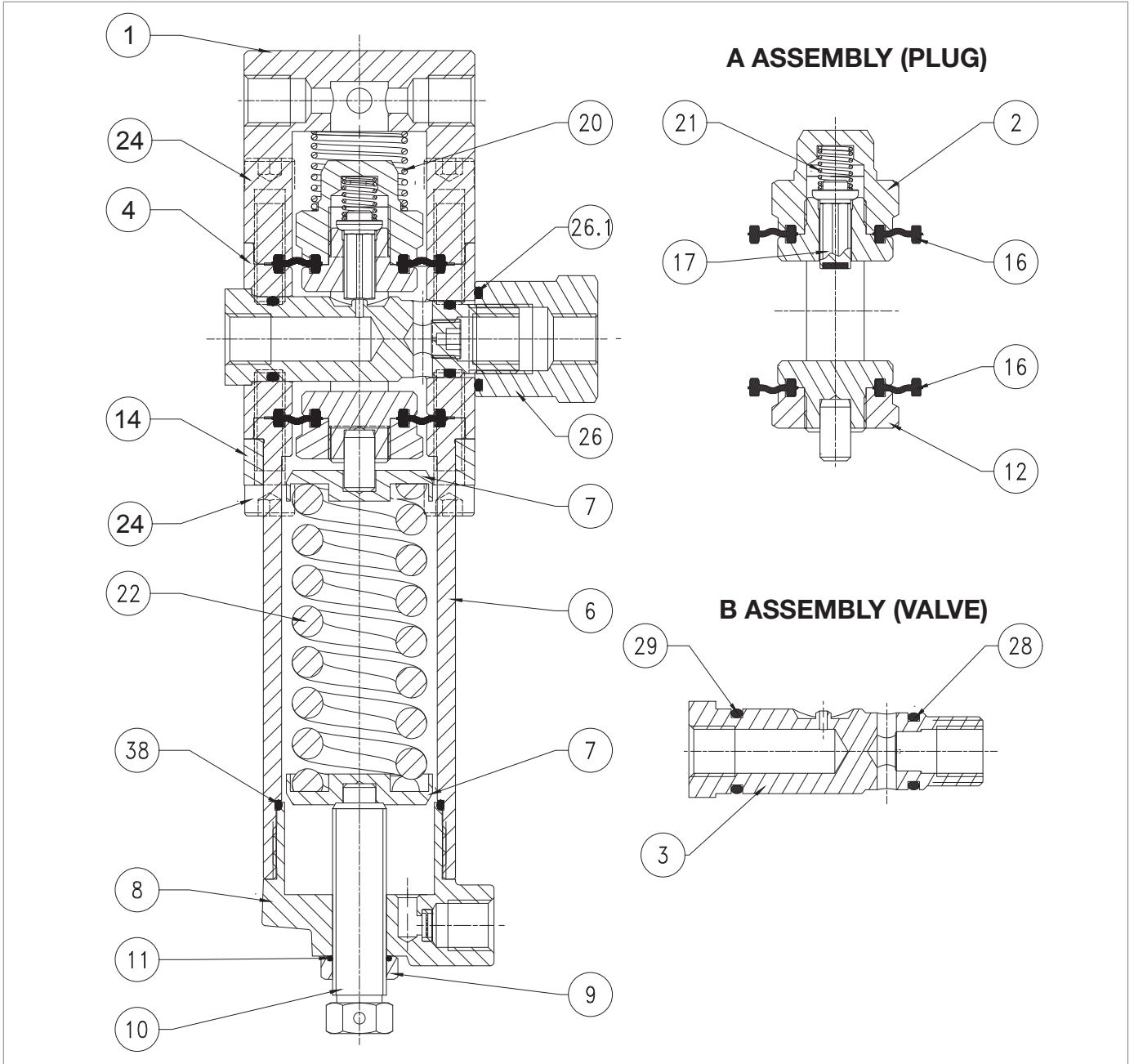





Fig. 9.50. Pilot 207/A

Step	Action
1	Loosen the nut (9).
2	Completely release the spring (22) by turning the adjusting screw (10).
3	Remove the adjusting screw (10) together with the cap (9).
4	Remove the cap (8).
	Remove the O-ring (38) from the cap (8) and replace it, lubricating it with synthetic grease.
5	<div style="border: 1px solid black; padding: 5px;">  NOTICE! Before inserting the replacement O-ring, clean the retaining slots with a cleaning solution. </div>
6	Remove the spring (22) and the spring supports (7).
7	Undo and remove the screws of the lower section (24).
8	Remove the bracket (14) from the sleeve (6).
9	Remove the sleeve (6).
10	Undo and remove the screws of the upper section (24).
11	Remove the pilot cover (1).
12	Remove the spring (20).
13	Unscrew and remove the nut (26).
	Remove the O-ring (26.1) from the nut (26) and replace it, lubricating it with synthetic grease.
14	<div style="border: 1px solid black; padding: 5px;">  NOTICE! Before inserting the replacement O-ring, clean the retaining slots with a cleaning solution. </div>
15	Unscrew and remove the pilot nut (2).
16	Remove the spring (21).
17	Remove and replace the plug (17).
18	Remove and replace the upper diaphragm (16).
19	Pull out the "B" (valve) assembly.
	Remove the O-rings (28, 29) from the valve seat (3) and replace them, lubricating them with synthetic grease.
20	<div style="border: 1px solid black; padding: 5px;">  NOTICE! Before inserting the replacement O-rings, clean the retaining slots with a cleaning solution. </div>
21	Remove assembly "A" (plug) from the valve body (4) by pushing it from the top downwards.
22	Unscrew and remove the nut (12).
	Remove and replace the lower diaphragm (16), lubricating the lanyards with synthetic grease.
23	<div style="border: 1px solid black; padding: 5px;">  NOTICE! Before inserting the replacement diaphragm, clean the retaining slots with a cleaning solution. </div>
24	Place and fix the nut (12) according to the following tightening torque: <ul style="list-style-type: none"> Pilot 207/A: Tab. 9.81



Pilot 207/A

Step	Action
25	Insert assembly "A" (plug) from top to bottom into the valve body (4). <div style="border: 1px solid black; padding: 5px;">  NOTICE! <ul style="list-style-type: none"> • Take care not to damage the diaphragms (16) during this step. • Make sure the marking on the lower section of the headframe is parallel to the axis of the hole for inserting the seat (3) into the valve body (4). </div>
26	Insert assembly "B" (valve) into the valve body (4). <div style="border: 1px solid black; padding: 5px;">  NOTICE! Take care not to damage the O-rings (28, 29) and the valve seat (3). </div>
27	Screw in the nut (26) according to the following tightening torque: <ul style="list-style-type: none"> • Pilot 207/A: Tab. 9.81
28	Put the upper diaphragm (16) back in place, lubricating the lanyards with synthetic grease. <div style="border: 1px solid black; padding: 5px;">  NOTICE! Before inserting the replacement diaphragm, clean the retaining slots with a cleaning solution. </div>
29	Put the plug (17) and then the spring (21) back in place.
30	Refit and fix the pilot nut (2) according to the following tightening torque: <ul style="list-style-type: none"> • Pilot 207/A: Tab. 9.81
31	Fit the spring (20).
32	Fit the cover (1).
33	Insert and fix the screws of the upper section (24) according to the following tightening torque: <ul style="list-style-type: none"> • Pilot 207/A: Tab. 9.81
34	Fit the sleeve (6) and the bracket (14).
35	Insert and fix the screws of the lower section (24) according to the following tightening torque: <ul style="list-style-type: none"> • Pilot 207/A: Tab. 9.81
36	Fit the spring (22) and the spring supports (7).
37	Unscrew the cap (8).
38	Remove and replace the O-ring (11) in the nut (9). <div style="border: 1px solid black; padding: 5px;">  NOTICE! Before inserting the replacement O-ring, clean the retaining slots with a cleaning solution. </div>
39	Fit the adjusting screw (10) together with the cap (9).

Tab. 9.98.

 **WARNING!**

Ensure that all parts have been fitted correctly.

9.4.6.4 - PRE-REGULATOR R14/A

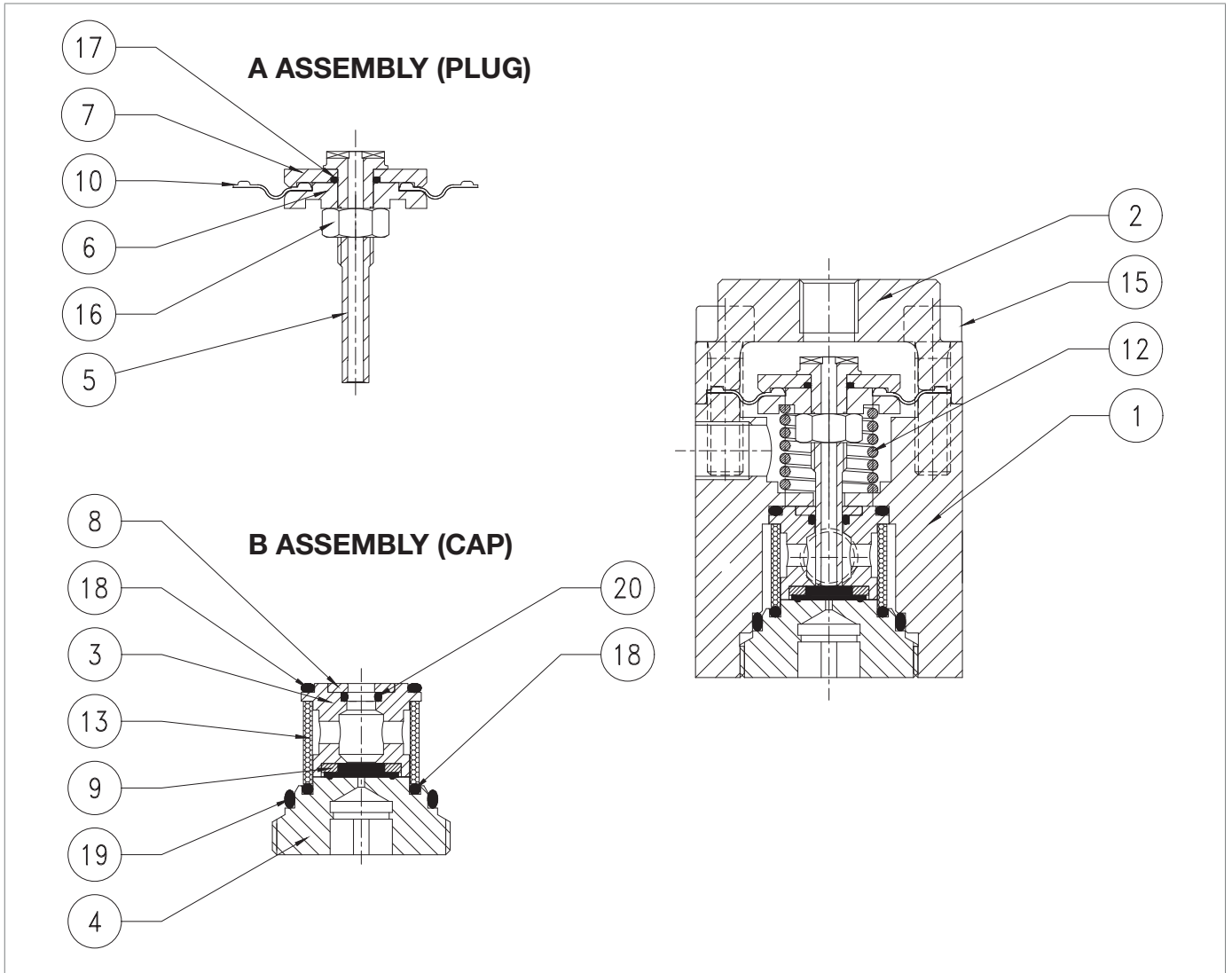





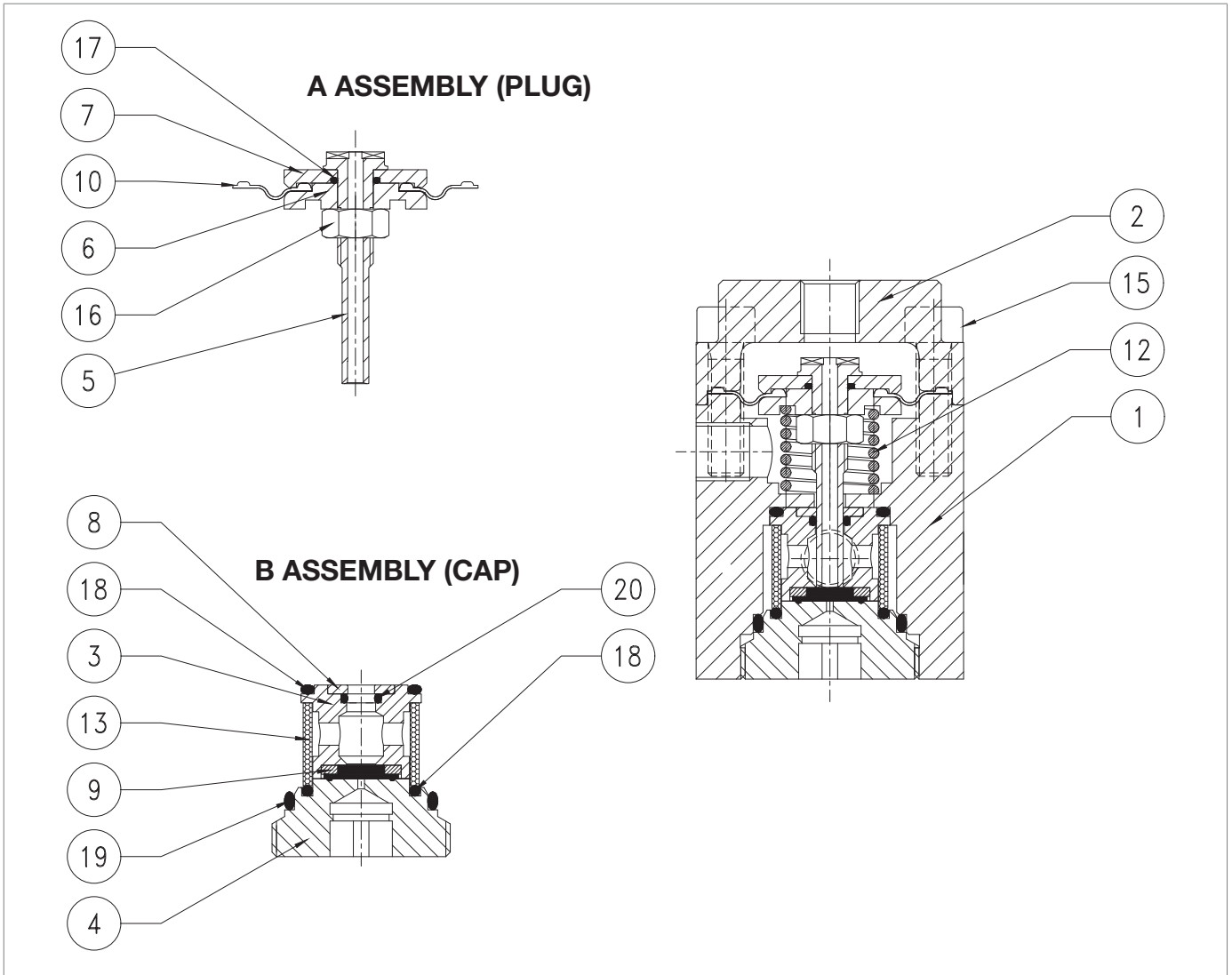

Fig. 9.51. Pre-regulator R14/A

Step	Action
1	Undo and remove the screws (15).
2	Remove the cover (2)
3	Pull out the "A" (plug) assembly.
4	Remove the spring (12).
5	Unscrew and remove the nut (16).
6	Insert the diaphragm protection disc (6) and the diaphragm (10).
7	Remove and replace the O-ring (17) from the diaphragm protection disc (7), lubricating it with synthetic grease. <div style="border: 1px solid black; padding: 5px;">  NOTICE! Before inserting the replacement O-ring, clean the retaining slots with a cleaning solution. </div>
8	Remove and replace the gasket (10). <div style="border: 1px solid black; padding: 5px;">  NOTICE! Before inserting the replacement diaphragm, clean the retaining slots with a cleaning solution. </div>
9	Fit the diaphragm protection disc (7).
10	Fit and fix the nut (16) into the plug (5) according to the following tightening torque: <ul style="list-style-type: none"> • R14/A: Tab. 9.82
11	Unscrew and remove assembly "B" (cap) by adjusting the cap (4).
12	Take out the plug guide (3).
13	Remove the O-ring (18) from the plug guide (3) and replace it, lubricating it with synthetic grease. <div style="border: 1px solid black; padding: 5px;">  NOTICE! Before inserting the replacement O-ring, clean the retaining slots with a cleaning solution. </div>
14	Remove the ring (8).
15	Remove the O-ring (20) from the plug guide (3) and replace it, lubricating it with synthetic grease. <div style="border: 1px solid black; padding: 5px;">  NOTICE! Before inserting the replacement O-ring, clean the retaining slots with a cleaning solution. </div>
16	Remove and replace the reinforced gasket (9). <div style="border: 1px solid black; padding: 5px;">  NOTICE! Before inserting the replacement O-ring, clean the retaining slots with a cleaning solution. </div>
17	Remove and replace the filter (13).
18	Remove the O-rings (18, 19) from the cap (4) and replace them, lubricating them with synthetic grease. <div style="border: 1px solid black; padding: 5px;">  NOTICE! Before inserting the replacement O-rings, clean the retaining slots with a cleaning solution. </div>
19	Put the filter (13) and the plug guide (3) in place.



Pre-regulator R14/A

Step	Action
20	Position the ring (8).
21	Position and secure the "B" assembly (cap). ! NOTICE! Take care not to damage the O-rings (18, 19) during this step.
22	Fit the spring (12).
23	Insert assembly "A" (plug) into the body (1). ! NOTICE! Before inserting the plug unit, lubricate the plug surface with silicone grease.
24	Fit the cover (2).
25	Insert and fix the screws (15) according to the following tightening torque: • R14/A: Tab. 9.82 ! NOTICE! Tighten the screws according to the cross diagram in paragraph 9.4.2.2.

Tab. 9.99.

! WARNING!

Ensure that all parts have been fitted correctly.

9.4.6.5 - 200/A SERIES PILOT RECONNECTION

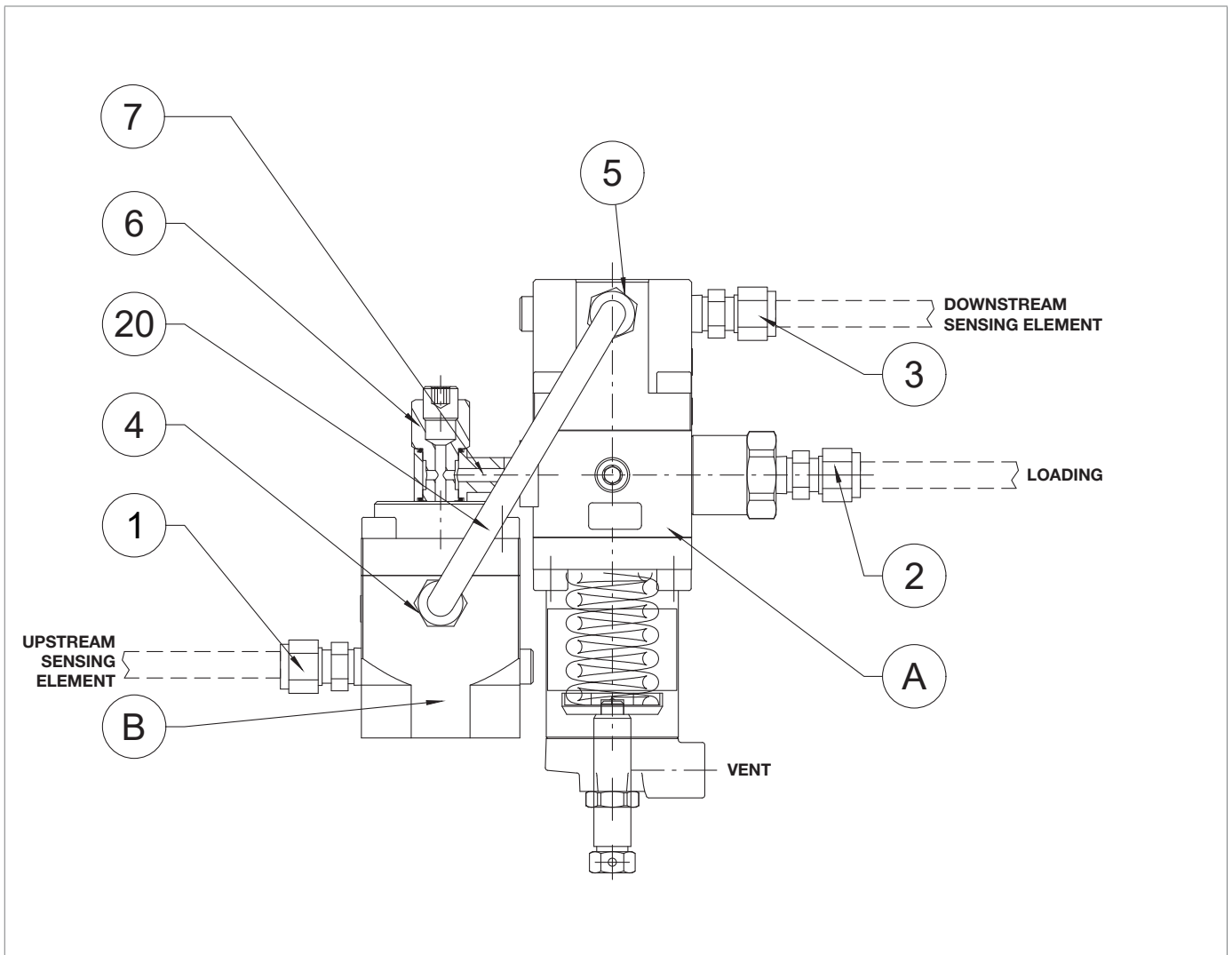

Fig. 9.52. 200/A series pilot

To reconnect the pilot, proceed as indicated in Tab. 9.100:

Step	Action
1	Insert and fix the screw (7) to the 200/A pilot.
2	Insert and fix the screw (6) to connect the R14/A pre-regulator to the 200/A pilot.
3	Connect the pipe (20) by adjusting the fittings (4, 5).
4	Insert and fix the fixing screw to connect the pilot to the regulator.
5	Connect the sensing lines between the pilot and the regulator by adjusting the fittings (1, 2, 3).

Tab. 9.100.

 **WARNING!**

Ensure that all parts have been fitted correctly.

9.4.7 - M/A ACCELERATING VALVE MAINTENANCE PROCEDURE

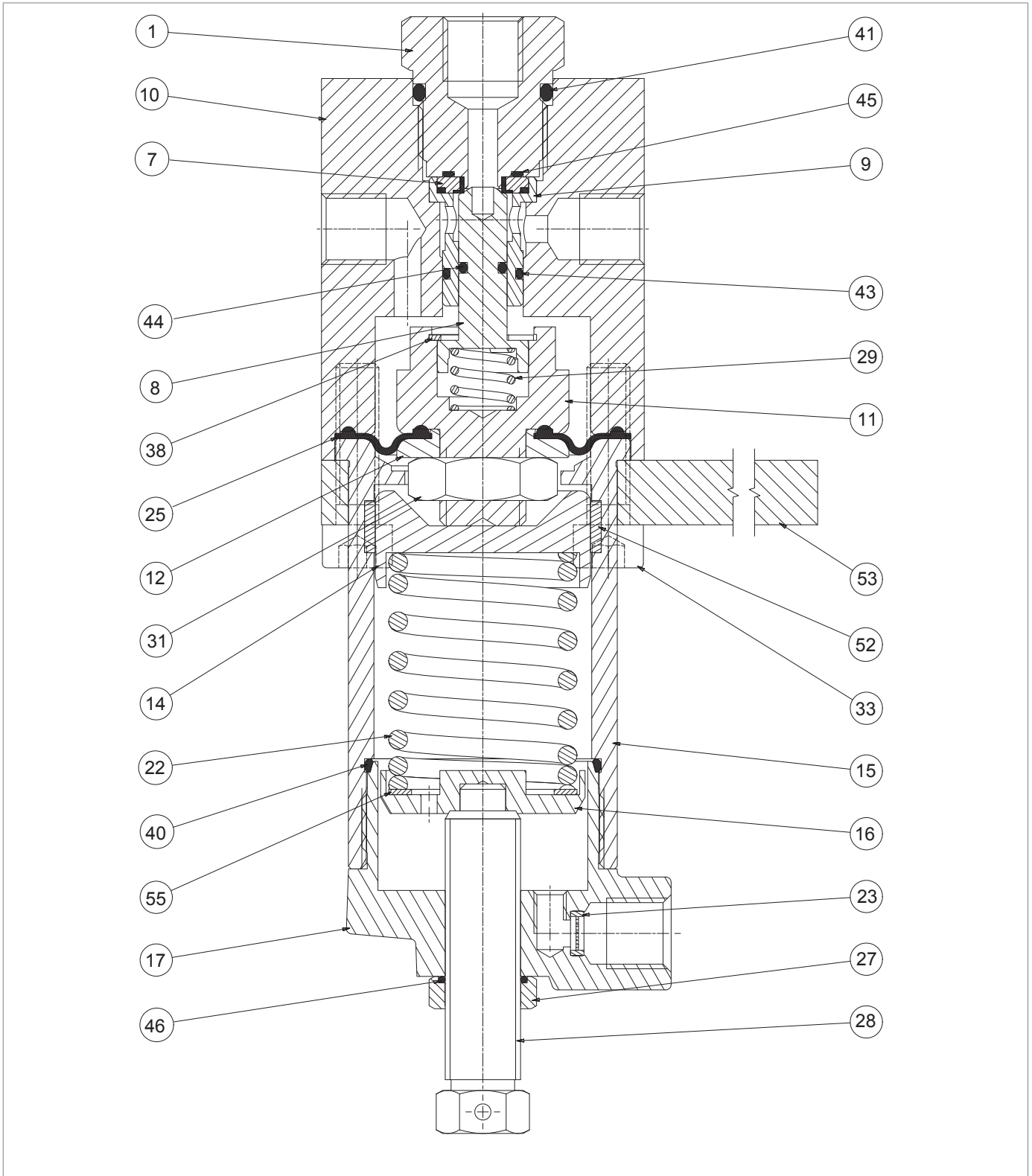





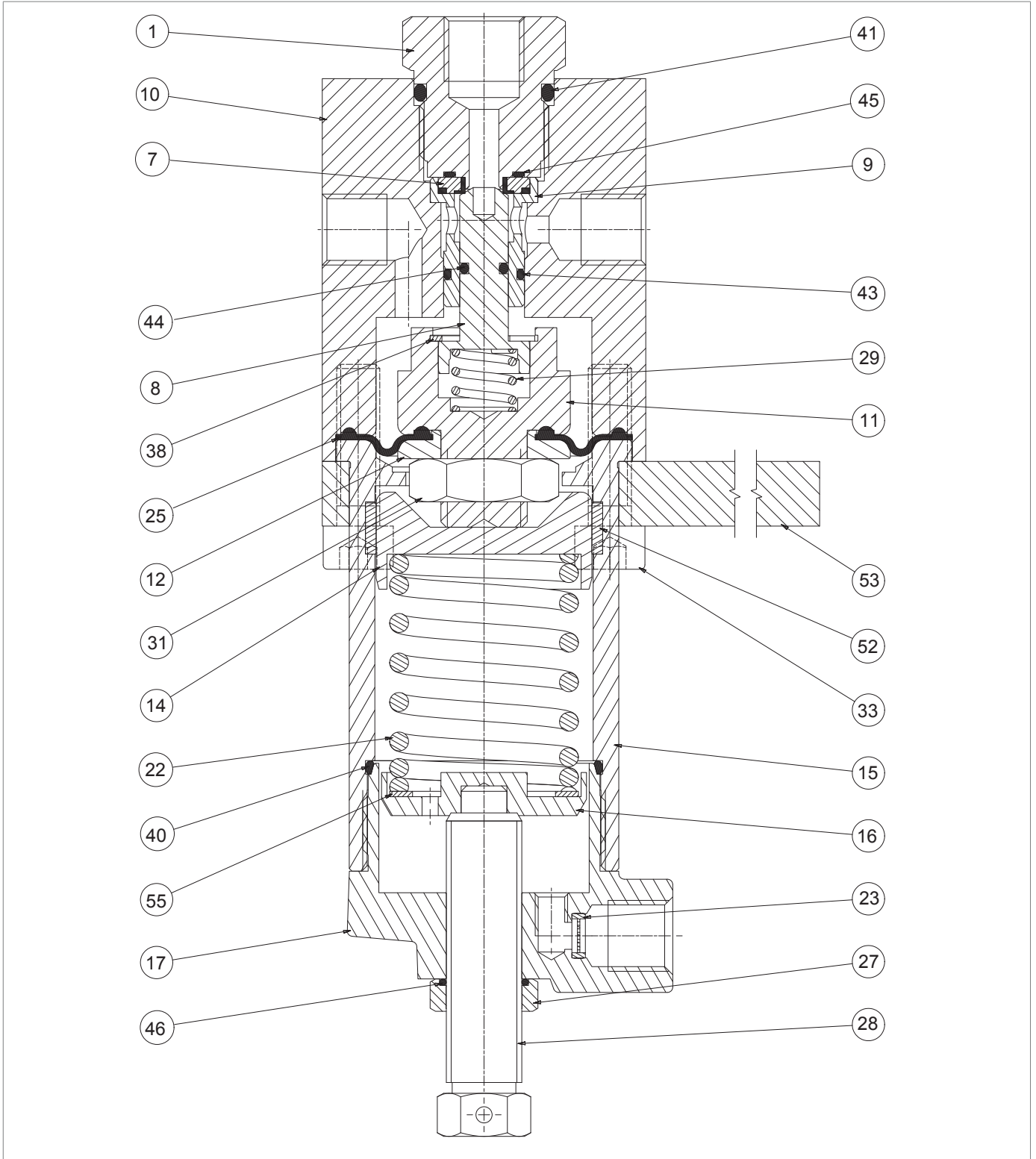





Fig. 9.53. M/A accelerating valve

Step	Action
1	Loosen the nut (27).
2	Completely release the spring (22) by turning the adjusting screw (28).
3	Remove the adjusting screw (28) together with the nut (27).
4	Remove the cap (17).
	Remove the O-ring (40) from the cap (17) and replace it, lubricating it with synthetic grease.
5	 NOTICE! Before inserting the replacement O-ring, clean the retaining slots with a cleaning solution.
6	Remove the lower spring support (16) together with the ring (55).
7	Remove the spring (22).
8	Remove the upper spring support (14).
9	Undo and remove the screws of the lower section (33).
10	Remove the bracket (53) from the sleeve (15).
11	Remove the sleeve (15).
	Remove and replace the I/DWR (52) from the sleeve (15).
12	 NOTICE! Before inserting the replacement I/DWR, clean the retaining slots with a cleaning solution.
13	Take out the diaphragm/plug unit (8,11,12, 25, 29, 31).
14	Unscrew and remove the nut (31).
15	Remove the diaphragm protection disc (12).
	Remove and replace the diaphragm (25).
16	 NOTICE! Before inserting the replacement diaphragm, clean the retaining slots with a cleaning solution.
17	Put the diaphragm protection disc (12) back in place.
18	Refit and secure the nut (31).
	Remove the O-ring (44) from the plug (8) and replace it, lubricating it with synthetic grease.
19	 NOTICE! Before inserting the replacement O-ring, clean the retaining slots with a cleaning solution.
20	Unscrew and remove the gasket support (1).
	Remove the O-rings (41, 45) from the gasket support (1) and replace them, lubricating them with synthetic grease.
21	 NOTICE! Before inserting the replacement O-rings, clean the retaining slots with a cleaning solution.
22	Take out the plug guide (9).
23	Remove and replace the reinforced gasket (7) from the plug guide (9).



M/A accelerating valve

Step	Action
24	Remove the O-ring (43) from the plug guide (9) and replace it, lubricating it with synthetic grease. <div style="border: 1px solid black; padding: 2px;">  NOTICE! Before inserting the replacement O-ring, clean the retaining slots with a cleaning solution. </div>
25	Fit the plug guide (9) together with the reinforced gasket (7).
26	Place the gasket support (1) in the body (10).
27	Take out the diaphragm/plug unit (8, 11, 12, 25, 29, 31). <div style="border: 1px solid black; padding: 2px;">  NOTICE! Before inserting the diaphragm/plug unit, lubricate the plug (8) surface with silicone grease. </div>
28	Fit the sleeve (15) and the bracket (53).
29	Insert and fix the screws (33). <div style="border: 1px solid black; padding: 2px;">  NOTICE! Tighten the screws according to the cross diagram in paragraph 9.4.2.2. </div>
30	Position the upper spring support (14) together with the spring (22).
31	Fit the lower spring support (16) together with the ring (55).
32	Fit and secure the cap (17).
33	Remove and replace the O-ring (46) in the nut (27). <div style="border: 1px solid black; padding: 2px;">  NOTICE! Before inserting the replacement O-ring, clean the retaining slots with a cleaning solution. </div>
34	Fit the adjusting screw (28) together with the nut (27).

Tab. 9.101.

 **WARNING!**

Ensure that all parts have been fitted correctly.

9.4.8 - MAINTENANCE PROCEDURE FOR PRESSURE SWITCHES MOD. 100

9.4.8.1 - PRESSURE SWITCH MOD. 102M/102MH

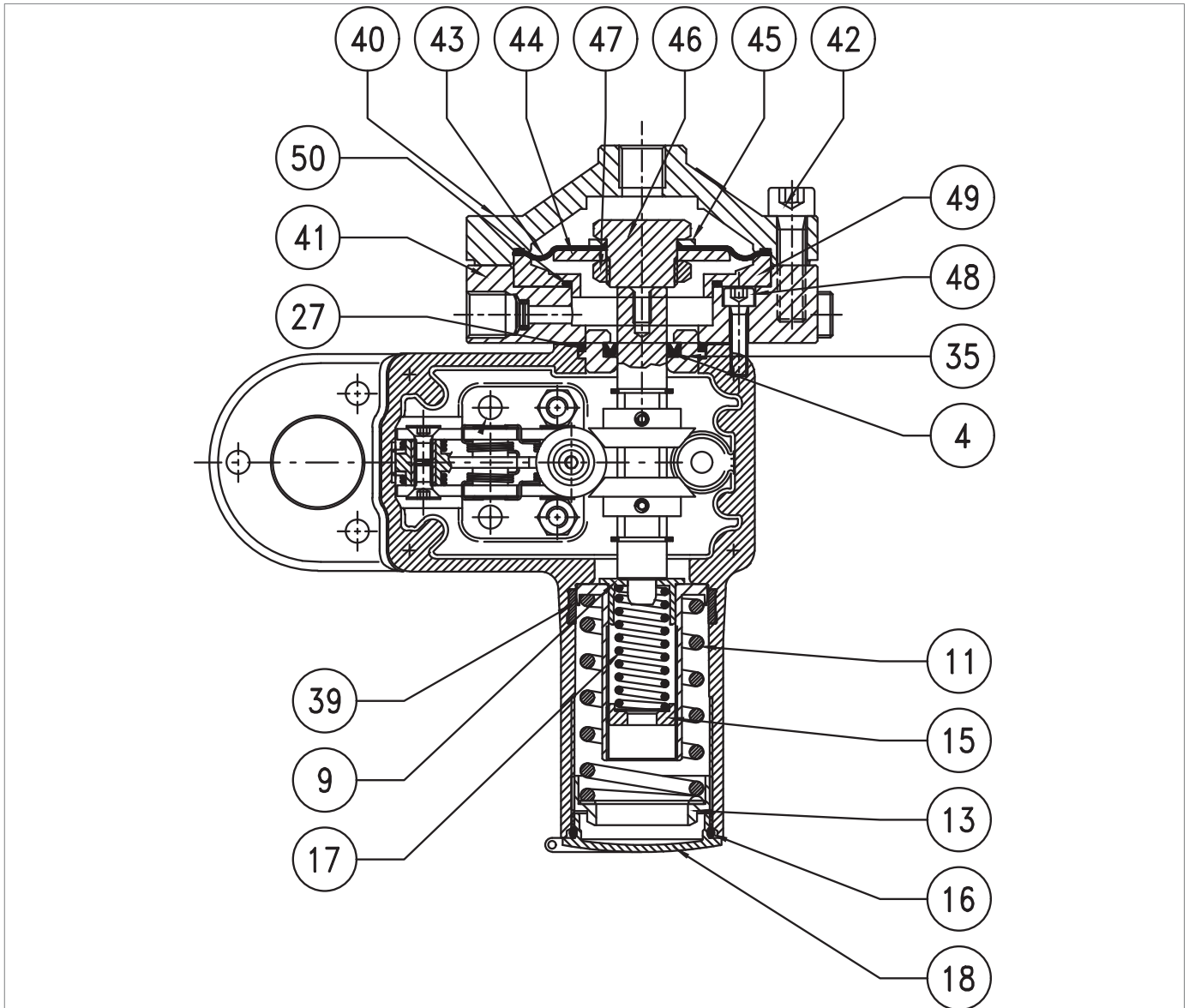
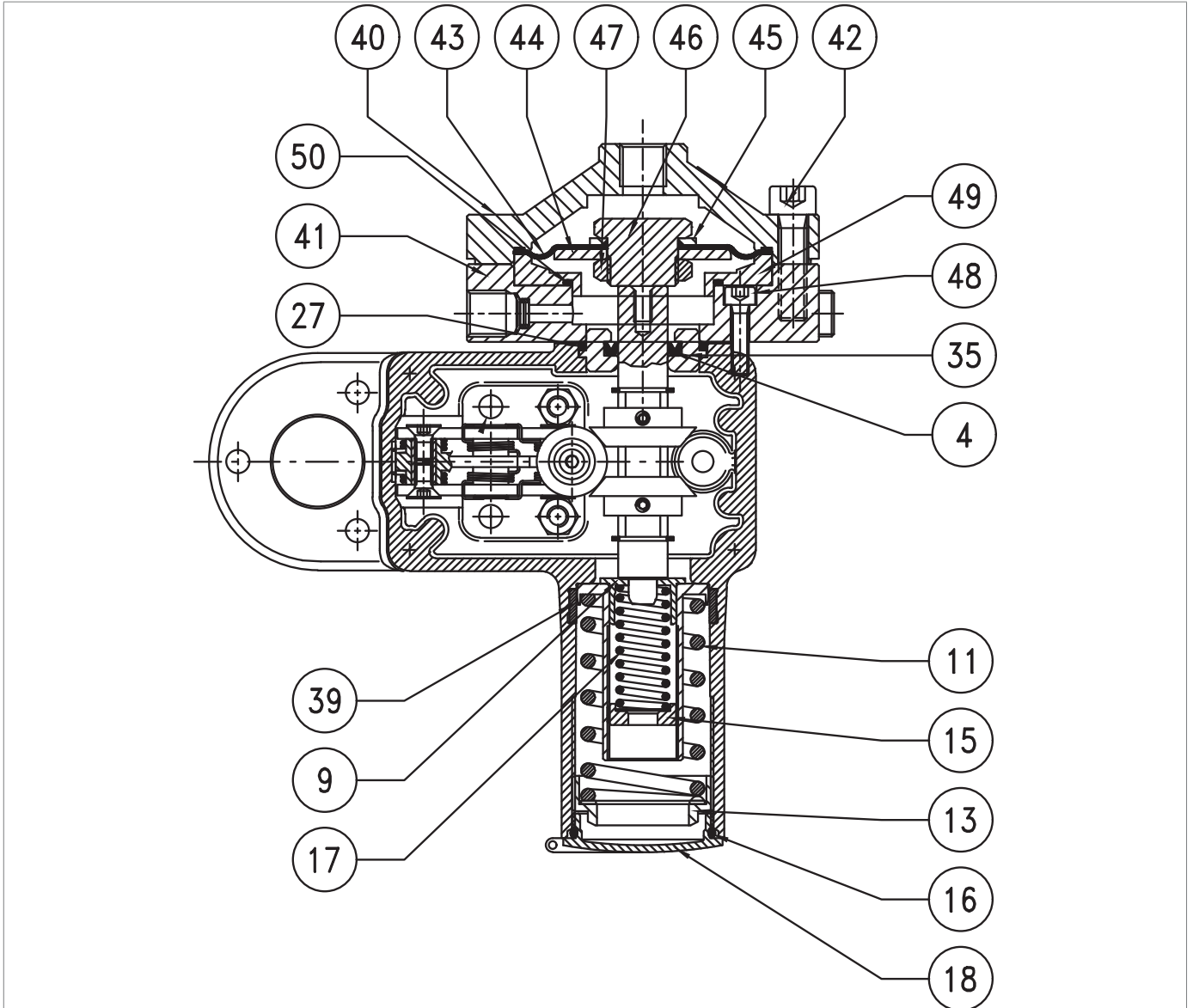

Fig. 9.54. Pressure switch Mod. 102M/102MH

Step	Action
1	Unscrew and remove the cap (18).
2	Remove the O-ring (16) from the cover (18) and replace it, lubricating it with synthetic grease. ! NOTICE! Before inserting the replacement O-ring, clean the retaining slots with a cleaning solution.
3	Completely release the spring (11) by adjusting the ring nut (13).
4	Completely release the minimum pressure spring (17) by adjusting the ring nut (15). ! NOTICE! The minimum spring may not be installed.
5	Remove the ring nut (13), the spring (11) and the spring support (17).
6	Remove the I/DWR ring (39) from the pressure switch sleeve and replace it, lubricating it with synthetic grease. ! NOTICE! Before inserting the replacement I/DWR ring, clean the retaining slots with a cleaning solution.
7	Undo and remove the screws (42).
8	Remove the upper cover (40).
9	Take out the diaphragm unit (43, 44, 45, 46, 47).
10	Unscrew the nut (47).
11	Remove the diaphragm protection disc (44).
12	Remove and replace the diaphragm (43), lubricating the lanyard with synthetic grease. ! NOTICE! Before inserting the replacement diaphragm, clean the retaining slots with a cleaning solution.
13	Fit the diaphragm protection disc (44).
14	Place and fix the nut (47) according to the following tightening torque: <ul style="list-style-type: none"> • Mod. 102M/102MH: Tab. 9.83
15	Remove the ring (49).
16	Undo and remove the screws (48).
17	Remove the lower lid (41).
18	Remove the O-ring (50) from the nut (49) and replace it, lubricating it with synthetic grease. ! NOTICE! Before inserting the replacement O-ring, clean the retaining slots with a cleaning solution.
19	Remove the bush (35).
20	Remove the O-ring (27) from the bush (35) and replace it, lubricating it with synthetic grease. ! NOTICE! Before inserting the replacement O-ring, clean the retaining slots with a cleaning solution.



Pressure switch Mod. 102M/102MH

Step	Action
21	<p>Remove the U-shaped ring (4) from the bush (35) and replace it, lubricating it with synthetic grease.</p> <p>NOTICE! Before inserting the replacement U-ring, clean the retaining slots with a cleaning solution.</p>
22	<p>Position the bush (35) together with the O-ring (27).</p> <p>NOTICE! Before inserting the bush (35), lubricate the inner surface with silicone grease.</p>
23	<p>Fit the lower cover (41).</p> <p>NOTICE! Make sure there is a gasket between the lower cover and the pressure switch body.</p>
24	<p>Insert and fasten screws (48) according to torque:</p> <ul style="list-style-type: none"> Mod. 102M/102MH: Tab. 9.83 <p>NOTICE! Tighten the screws according to the cross diagram in paragraph 9.4.2.2.</p>
25	Insert the ring (49).
26	Put the diaphragm unit in place (43, 44, 45, 46, 47).
27	Fit the lid (40).
28	<p>Insert and fasten screws (42) according to torque:</p> <ul style="list-style-type: none"> Mod. 102M/102MH: Tab. 9.83 <p>NOTICE! Tighten the screws according to the cross diagram in paragraph 9.4.2.2.</p>
29	<p>Completely release the maximum pressure spring (11) by adjusting the ring nut (13).</p> <p>NOTICE! For spring calibration, please refer to chapter "13 - Calibration tables".</p>
30	<p>Position the minimum spring (17) by adjusting the ring nut (15).</p> <p>NOTICE!</p> <ul style="list-style-type: none"> Check that it is present; For spring calibration, please refer to chapter "13 - Calibration tables".
31	Insert and fix the cap (18).

Tab. 9.102.

WARNING!

Ensure that all parts have been fitted correctly.

9.4.8.2 - PRESSURE SWITCH MOD. 103M/103MH

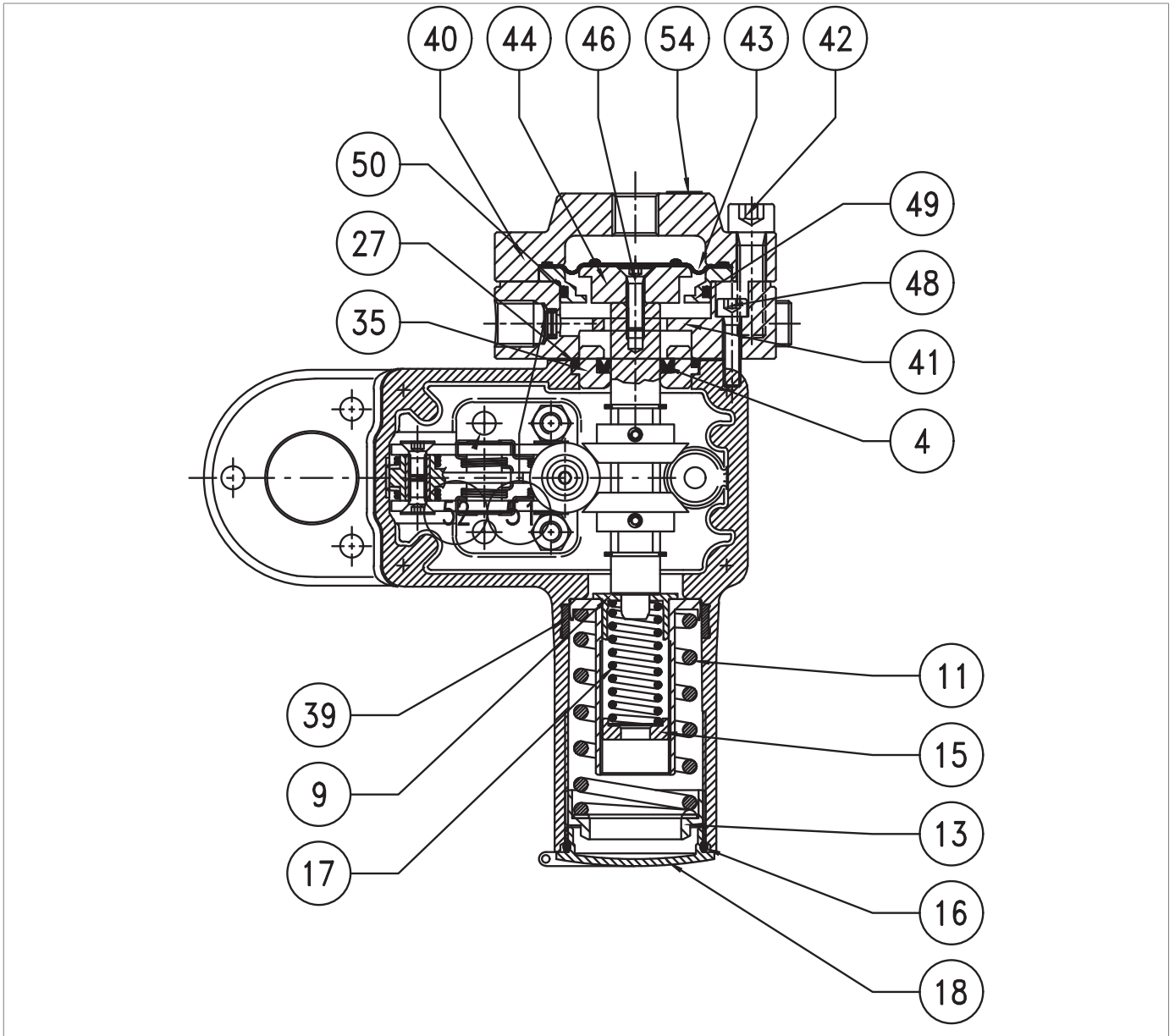
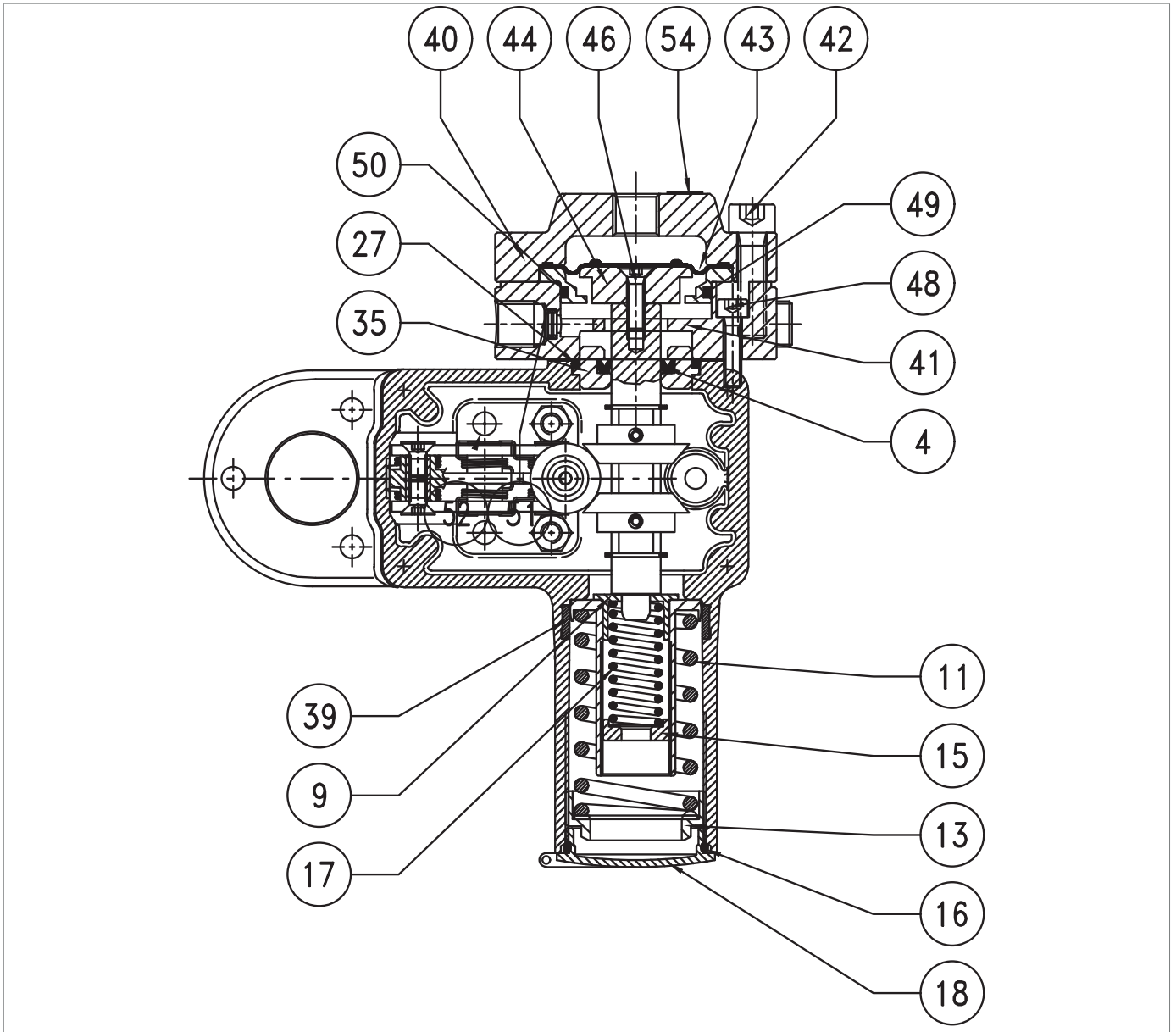

Fig. 9.55. Pressure switch Mod. 103M/103MH

Step	Action
1	Unscrew and remove the cap (18).
2	Remove the O-ring (16) from the cover (18) and replace it, lubricating it with synthetic grease. ! NOTICE! Before inserting the replacement O-ring, clean the retaining slots with a cleaning solution.
3	Completely release the spring (11) by adjusting the ring nut (13).
4	Completely release the minimum pressure spring (17) by adjusting the ring nut (15). ! NOTICE! The minimum spring may not be installed.
5	Remove the ring nut (13), the spring (11) and the spring support (17).
6	Remove the I/DWR ring (39) from the pressure switch sleeve and replace it, lubricating it with synthetic grease. ! NOTICE! Before fitting the replacement I/DWR ring, clean the retaining slots using a cleaning solution.
7	Undo and remove the screws (42).
8	Remove the upper cover (40).
9	Remove and replace the diaphragm (43), lubricating the lanyard with synthetic grease. ! NOTICE! Before inserting the replacement diaphragm, clean the retaining slots with a cleaning solution.
10	Undo and remove the screws (46).
11	Remove diaphragm protection disc (44).
12	Remove the ring (49).
13	Remove the O-ring (50) from the ring (49) and replace it. ! NOTICE! Before inserting the replacement O-ring, clean the retaining slots with a cleaning solution.
14	Undo and remove the screws (48).
15	Remove the lower lid (41).
16	Remove the bush (35).
17	Remove the O-ring (27) from the bush (35) and replace it, lubricating it with synthetic grease. ! NOTICE! Before inserting the replacement O-ring, clean the retaining slots with a cleaning solution.
18	Remove the U-shaped ring (4) from the bush (35) and replace it, lubricating it with synthetic grease. ! NOTICE! Before inserting the replacement U-ring, clean the retaining slots with a cleaning solution.



Pressure switch Mod. 103M/103MH

Step	Action
19	Position the bush (35) together with the O-ring (27). NOTICE! Before inserting the bush (35), lubricate the internal surface with silicone grease.
20	Remove the lower lid (41)
21	Insert and fix the screws (48) according to the following tightening torque: • Mod. 103M/103MH: Tab. 9.84 NOTICE! • Tighten the screws according to the cross diagram in paragraph 9.4.2.2; • Make sure there is a gasket between the lower cover and the pressure switch body.
22	Insert the ring (49).
23	Fit the diaphragm protection disc (44).
24	Insert and fix the screws (46) according to the following tightening torque: • Mod. 103M/103MH: Tab. 9.84 NOTICE! • Tighten the screws according to the cross diagram in paragraph 9.4.2.2; • Before inserting the screw (46), apply thread locking glue.
25	Fit the diaphragm (43).
26	Fit the lid (40).
27	Insert and fix the screws (42) according to the following tightening torque: • Mod. 103M/103MH: Tab. 9.84 NOTICE! Tighten the screws according to the cross diagram in paragraph 9.4.2.2.
28	Completely release the maximum pressure spring (11) by adjusting the ring nut (13). NOTICE! For spring calibration, please refer to chapter "13 - Calibration tables".
29	Position the minimum spring (17) by adjusting the ring nut (15). NOTICE! • If any; • For spring calibration, please refer to chapter "13 - Calibration tables".
30	Insert and fix the cap (18).

Tab. 9.103.

WARNING!

Ensure that all parts have been fitted correctly.

9.4.8.3 - PRESSURE SWITCH MOD. 104M/104MH - 105M/105MH

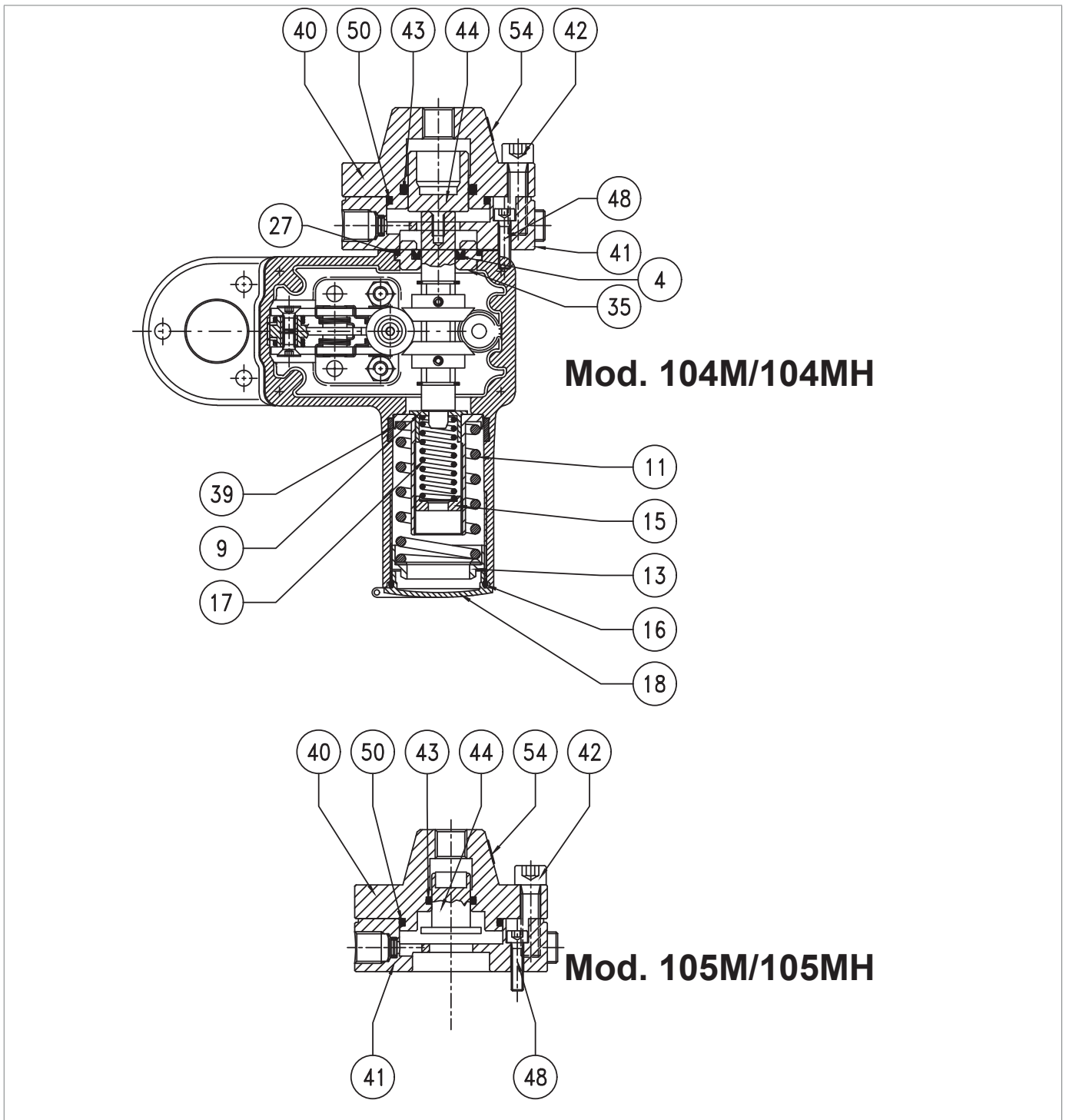
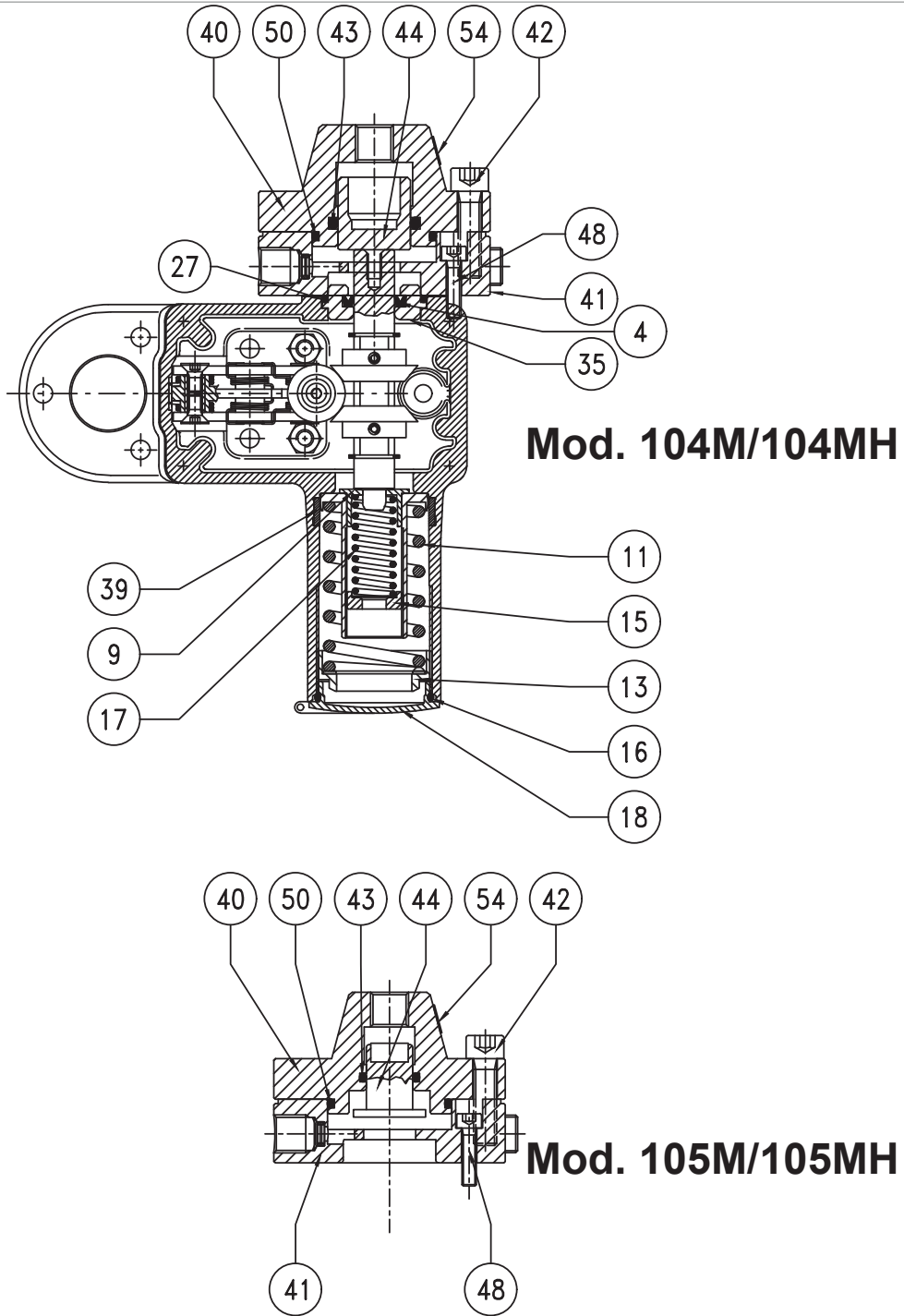





Fig. 9.56. Pressure switch Mod. 104M/104MH - 105M/105MH

Step	Action
1	Unscrew and remove the cap (18).
2	Remove the O-ring (16) from the cover (18) and replace it, lubricating it with synthetic grease. NOTICE! Before inserting the replacement O-ring, clean the retaining slots with a cleaning solution.
3	Completely release the spring (11) by adjusting the ring nut (13).
4	Completely release the minimum pressure spring (17) by adjusting the ring nut (15). NOTICE! The minimum spring may not be installed.
5	Remove the ring nut (13), the spring (11) and the spring support (17).
6	Remove the I/DWR ring (39) from the pressure switch sleeve and replace it, lubricating it with synthetic grease. NOTICE! Before fitting the replacement I/DWR ring, clean the retaining slots using a cleaning solution.
7	Undo and remove the screws (42).
8	Remove the upper cover (40) together with the piston (44).
9	Pull the piston (44) out of the upper cover (40).
10	Remove the O-rings (43, 50) from the upper cover (40) and replace them, lubricating them with synthetic grease. NOTICE! Before inserting the replacement O-rings, clean the retaining slots with a cleaning solution.
11	Refit the piston (44) into the upper cover (40).
12	Undo and remove the screws (48).
13	Remove the lower lid (41).
14	Remove the bush (35).
15	Remove the O-ring (27) from the bush (35) and replace it, lubricating it with synthetic grease. NOTICE! Before inserting the replacement O-ring, clean the retaining slots with a cleaning solution.
16	Remove the U-shaped ring (4) from the bush (35) and replace it, lubricating it with synthetic grease. NOTICE! Before inserting the replacement U-ring, clean the retaining slots with a cleaning solution.
17	Position the bush (35) together with the O-ring (27). NOTICE! Before inserting the bush (35), lubricate the internal surface with silicone grease.
18	Fit the lower cover (41). NOTICE! Make sure that the gasket is in place (28).



Pressure switch Mod. 104M/104MH - 105M/105MH

Step	Action
19	Insert and fix the screws (48) according to the following tightening torques: <ul style="list-style-type: none"> Mod. 104M/104MH - 105M/105MH: Tab. 9.85 <div style="border: 1px solid black; padding: 2px;">  NOTICE! </div> <p>Tighten the screws according to the cross diagram in paragraph 9.4.2.2.</p>
20	Fit the upper cover (40).
21	Insert and fix the screws (42) according to the following tightening torques: <ul style="list-style-type: none"> Mod. 104M/104MH - 105M/105MH: Tab. 9.85. <div style="border: 1px solid black; padding: 2px;">  NOTICE! </div> <p>Tighten the screws according to the cross diagram in paragraph 9.4.2.2.</p>
22	Completely release the maximum pressure spring (11) by adjusting the ring nut (13). <div style="border: 1px solid black; padding: 2px;">  NOTICE! </div> <p>For spring calibration, please refer to chapter "13 - Calibration tables".</p>
23	Completely release the minimum pressure spring (17) by turning the ring nut (15). <div style="border: 1px solid black; padding: 2px;">  NOTICE! </div> <ul style="list-style-type: none"> If any; For spring calibration, please refer to chapter "13 - Calibration tables".
24	Insert and fix the cap (18).

Tab. 9.104.

 **WARNING!**

Ensure that all parts have been fitted correctly.

9.4.9 - LINE OFF 2.0 MAINTENANCE PROCEDURE

9.4.9.1 - LINE OFF 2.0 DISCONNECTION

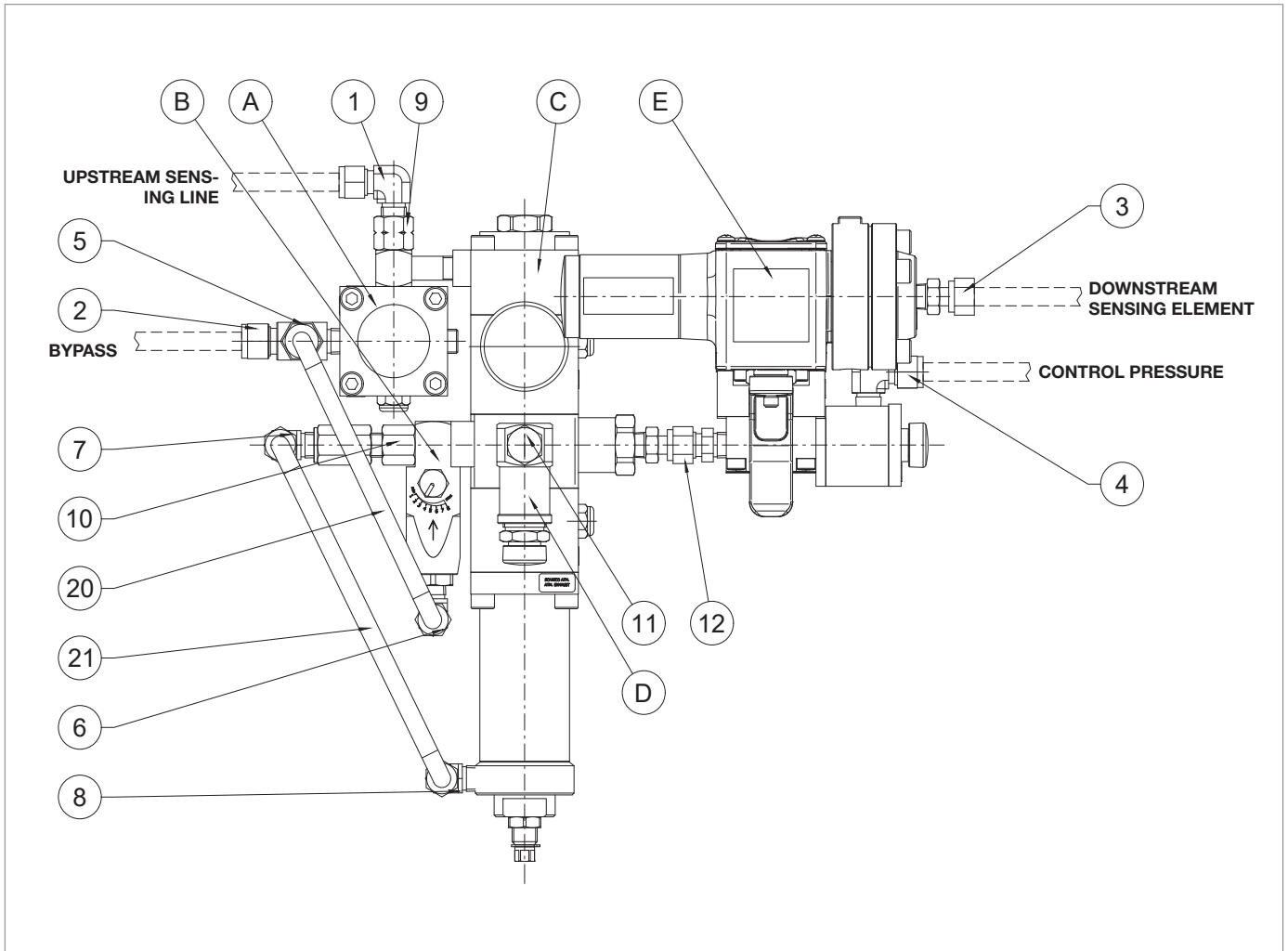

Fig. 9.57. LINE OFF 2.0

To disconnect, proceed as in Tab. 9.105:

Step	Action
1	Disconnect the pipes from the fittings (1, 2, 3, 4).
2	Unscrew and remove the fixing screw to disconnect the LINE OFF 2.0.
3	Disconnect the pipe (20) from the fittings (5, 6).
4	Disconnect the pipe (21) from the fittings (7, 8).
5	Remove assembly "A" (bypass device HP2/2) and adjust the fitting (9).
6	Remove assembly "B" (throttle valve AR100) and adjust the fitting (10).
7	Remove assembly "D" (safety valve VS/FI) and adjust the fitting (11).
8	Remove assembly "E" (valve 3/2 and control pressure switch) from assembly "C" (regulator R44/SS) and adjust the fitting (12).

Tab. 9.105.

9.4.9.2 - HP2/2 BYPASS DEVICE

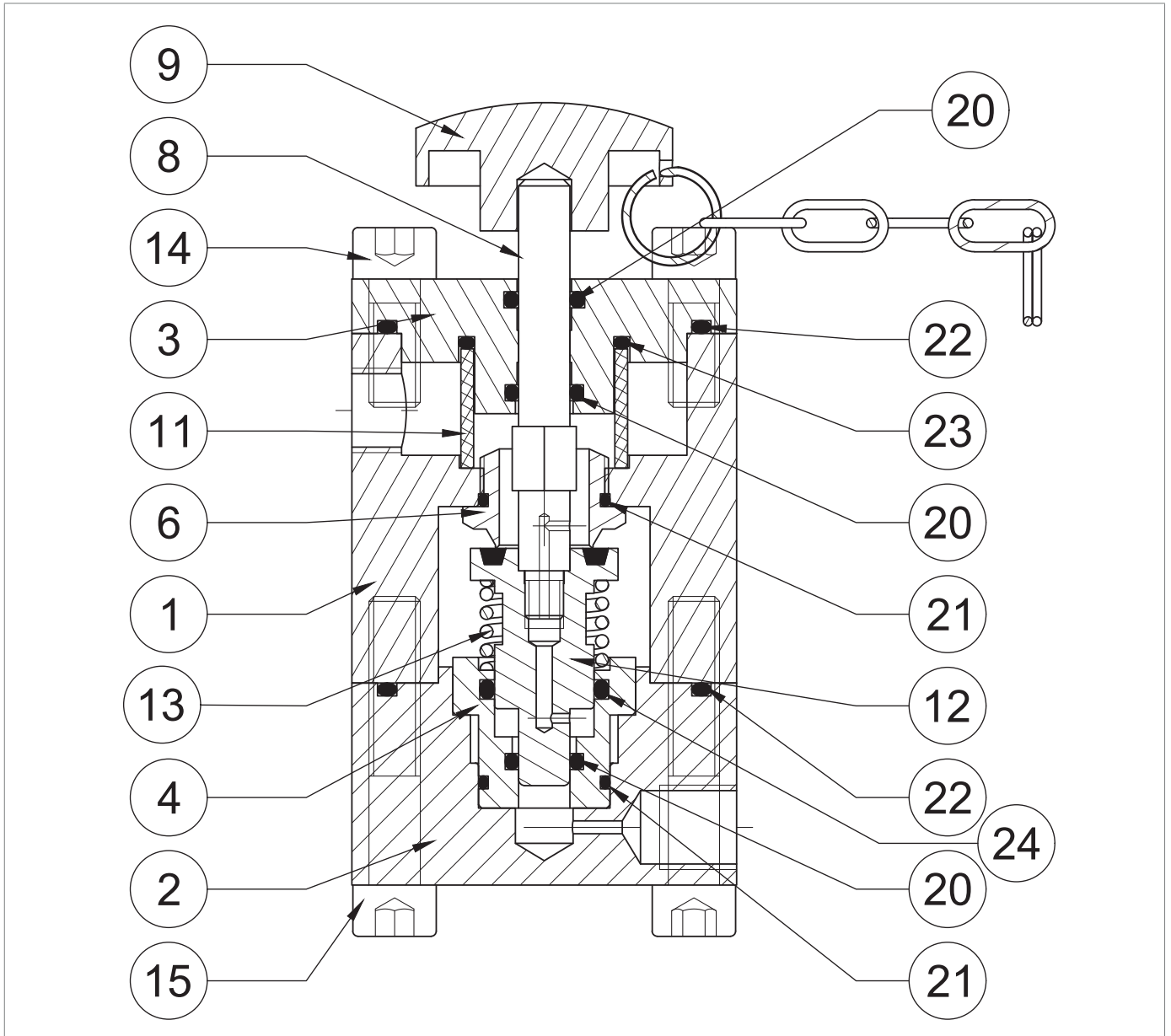







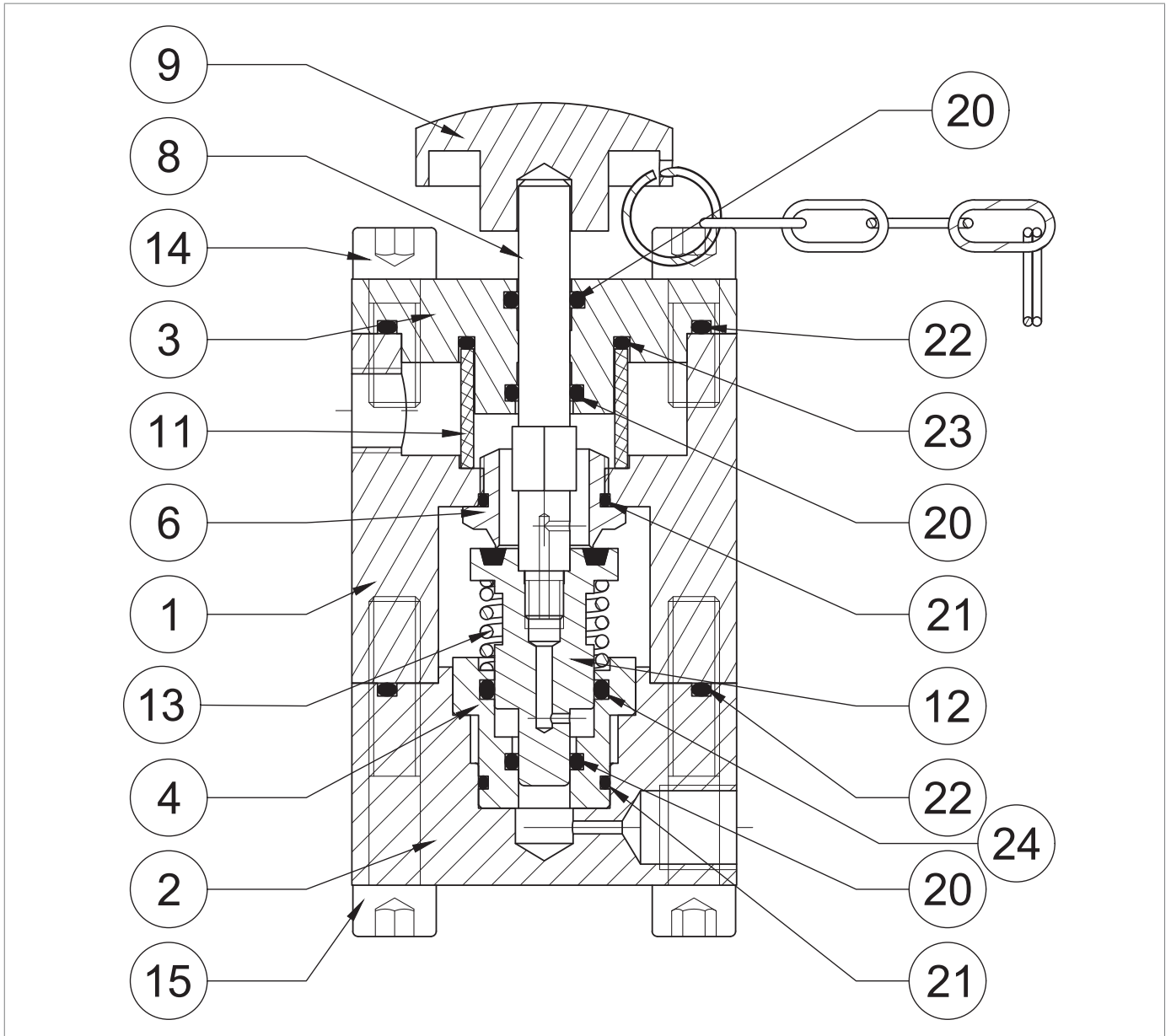





Fig. 9.58. HP2/2 bypass device

Step	Action
1	Remove the knob (9).
2	Undo and remove the screws (15).
3	Remove the cover (2) together with the bush (4), spring (13), plug (12) and stem (8).
4	Remove the bush (4), together with the spring (13), plug (12), stem (8) from the cover (2).
	Remove the O-ring (22) from the cover (2) and replace it, lubricating it with synthetic grease.
5	 NOTICE! Before inserting the replacement O-ring, clean the retaining slots with a cleaning solution.
6	Fit the plug (12) together with the stem (8).
7	Separate the stem (8) from the plug (12).
8	Replace the plug (12).
	Remove the O-rings (20, 21, 24) from the bush (4) and replace them, lubricating them with synthetic grease.
9	 NOTICE! Before inserting the replacement O-rings, clean the retaining slots with a cleaning solution.
	Undo and remove the screws (6).
10	 NOTICE! Attention do not to ruin the seat profile during this step.
	Remove the O-ring (21) from the seat (6) and replace it, lubricating it with synthetic grease.
11	 NOTICE! Before inserting the replacement O-ring, clean the retaining slots with a cleaning solution.
12	Undo and remove the screws (14).
13	Remove the flange (3).
	Remove the O-rings (22 , 23) from the flange (3) and replace them, lubricating them with synthetic grease.
14	 NOTICE! Before inserting the replacement O-rings, clean the retaining slots with a cleaning solution.
	Remove the O-rings (20) from the flange (3) and replace them, lubricating them with synthetic grease.
15	 NOTICE! Before inserting the replacement O-rings, clean the retaining slots with a cleaning solution.
16	Remove and replace the filter (11).
17	Put the flange (3) back in place.
	Insert and fix the screws (14) according to the following tightening torque:
	<ul style="list-style-type: none"> • HP2/2: Tab. 9.86
18	 NOTICE! Tighten the screws according to the cross diagram in paragraph 9.4.2.2.



HP2/2 bypass device

Step	Action
19	Fit and fix the seat (6) in the body (1). <div style="border: 1px solid black; padding: 5px;">  NOTICE! Care must be taken not to ruin the seat profile during this step. </div>
20	Fit the bush (4) in the cover (2).
21	Screw the stem (8) into the plug (12). <div style="border: 1px solid black; padding: 5px;">  NOTICE! Before fitting the stem (8), apply thread locking glue. </div>
22	Fit the spring (13).
23	Fit the plug (12) together with the stem (8) into the bush (4).
24	Fit the cover (2) together with the bush (4).
25	Insert and fix the screws (15) according to the following tightening torque: <ul style="list-style-type: none"> • HP2/2: Tab. 9.86 <div style="border: 1px solid black; padding: 5px;">  NOTICE! Tighten the screws according to the cross diagram in paragraph 9.4.2.2. </div>

Tab. 9.106.

 **WARNING!**

Ensure that all parts have been fitted correctly.

9.4.9.3 - PRESSURE REGULATOR R44/SS

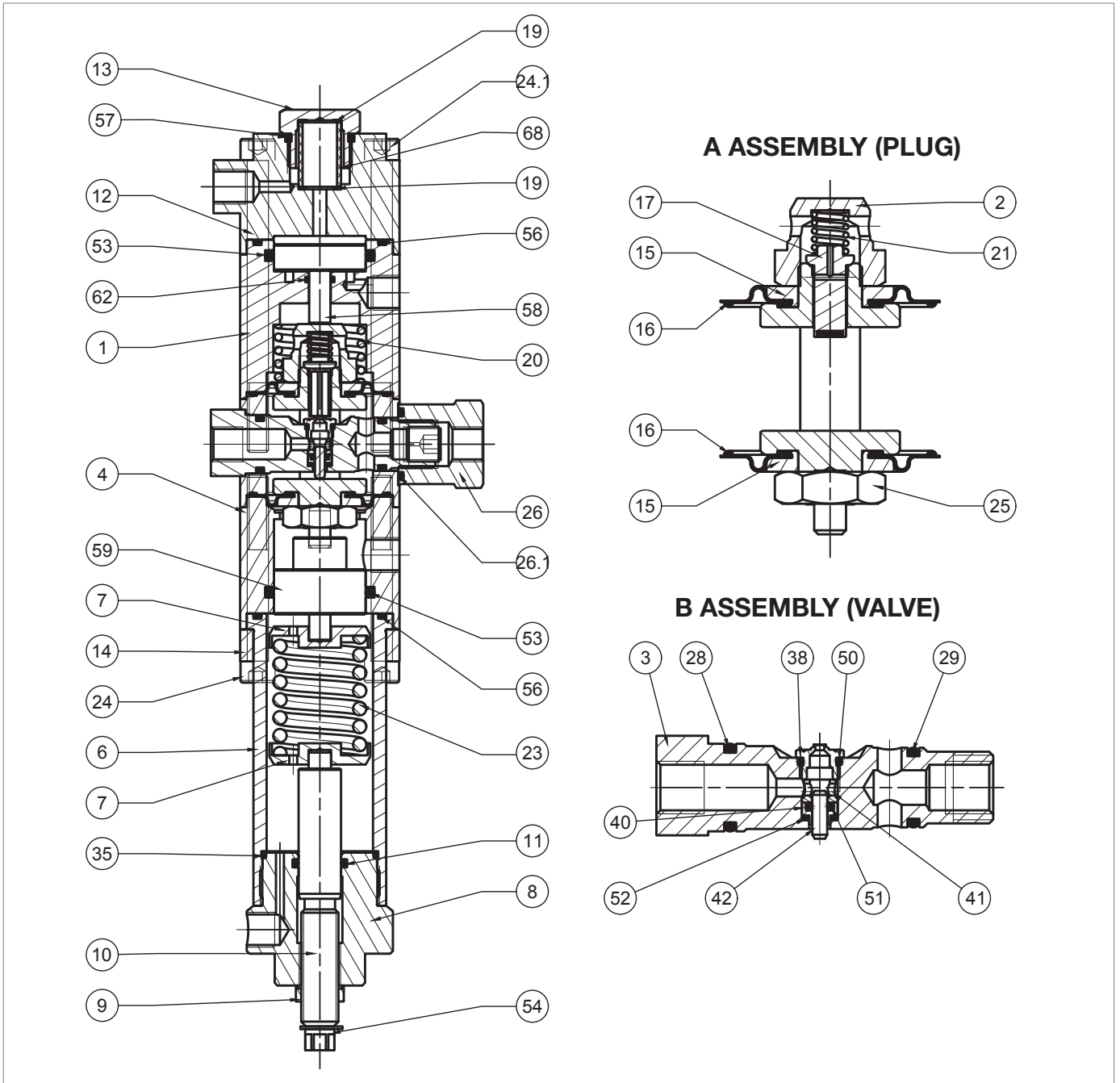





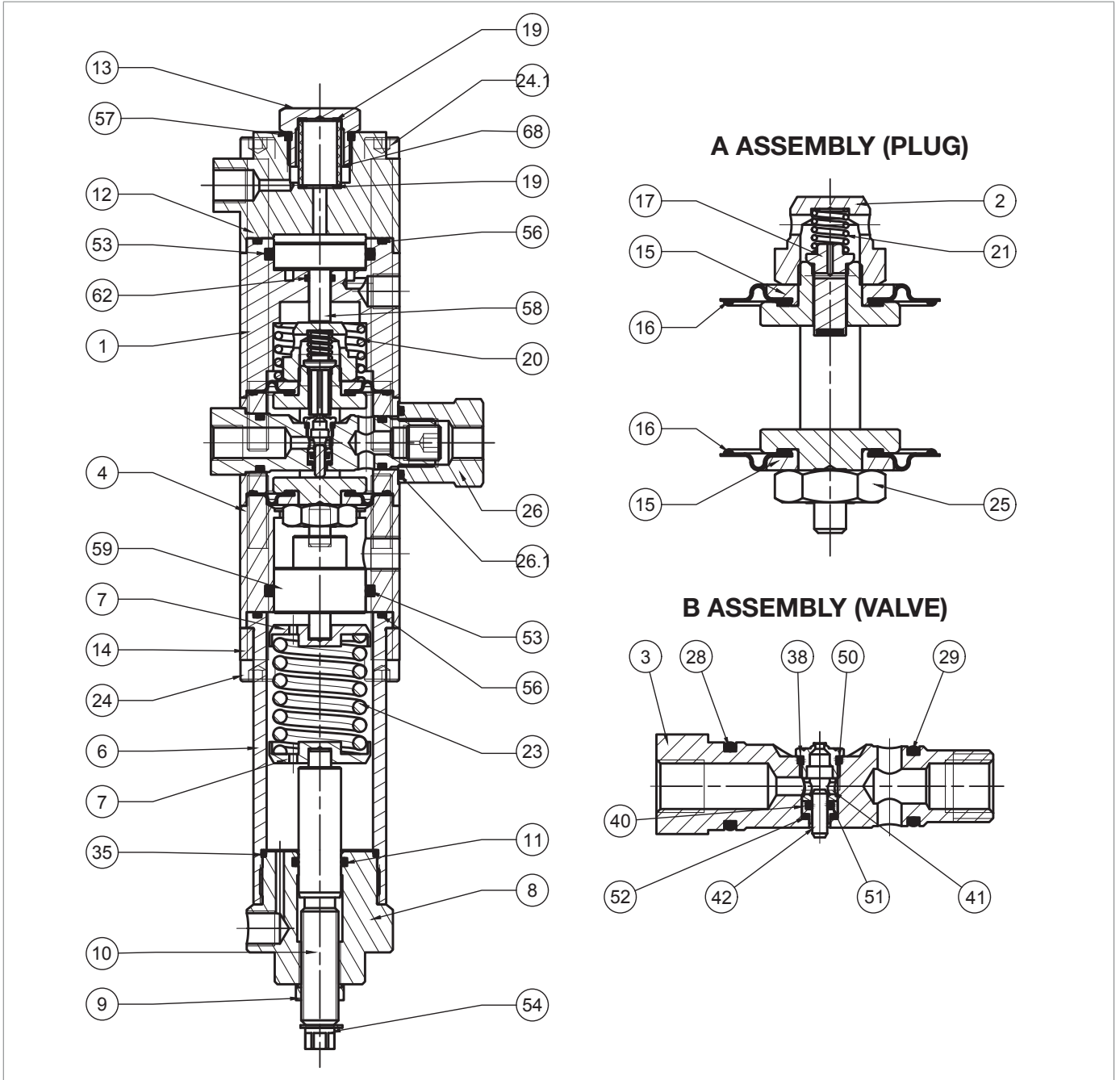

Fig. 9.59. Pressure regulator R44/SS

Step	Action
1	Remove the Seeger ring (54).
2	Unscrew the nut (9).
3	Completely release the spring (23) by turning the adjusting screw (10).
4	Unscrew and remove the cap (8).
5	Remove the spring (23) and the spring supports (7).
6	Remove the screw (10) from the cap (8) clockwise, from the inside outwards.
7	Remove the O-ring (11) from the cap (8) and replace it, lubricating it with synthetic grease. <div style="border: 1px solid black; padding: 5px;">  NOTICE! Before inserting the replacement O-ring, clean the retaining slots with a cleaning solution. </div>
8	Insert the screw (10) into the cap (8) anti-clockwise, from the outside inwards.
9	Insert the nut (9).
10	Fit the Seeger ring (54).
11	Undo the screws (24).
12	Remove the bracket (14).
13	Remove the sleeve (6).
14	Remove the O-ring (56) from the sleeve (6) and replace it, lubricating it with synthetic grease. <div style="border: 1px solid black; padding: 5px;">  NOTICE! Before inserting the replacement O-ring, clean the retaining slots with a cleaning solution. </div>
15	Remove the O-ring (35) from the sleeve (6) and replace it, lubricating it with synthetic grease. <div style="border: 1px solid black; padding: 5px;">  NOTICE! Before inserting the replacement O-ring, clean the retaining slots with a cleaning solution. </div>
16	Remove the spacer (4).
17	Take out the piston (59).
18	Remove the O-ring (53) from the spacer (4) and replace it, lubricating it with synthetic grease. <div style="border: 1px solid black; padding: 5px;">  NOTICE! Before inserting the replacement O-ring, clean the retaining slots with a cleaning solution. </div>
19	Unscrew and remove the cap (13).
20	Remove the O-ring (57) from the cap (13) and replace it, lubricating it with synthetic grease. <div style="border: 1px solid black; padding: 5px;">  NOTICE! Before inserting the replacement O-ring, clean the retaining slots with a cleaning solution. </div>
21	Remove and replace the filter (68).
22	Remove and replace the gaskets (19).
23	Undo and remove the screws (24.1).
24	Remove the cover (12).
25	Remove the cover (1).
26	Take out the piston (58).





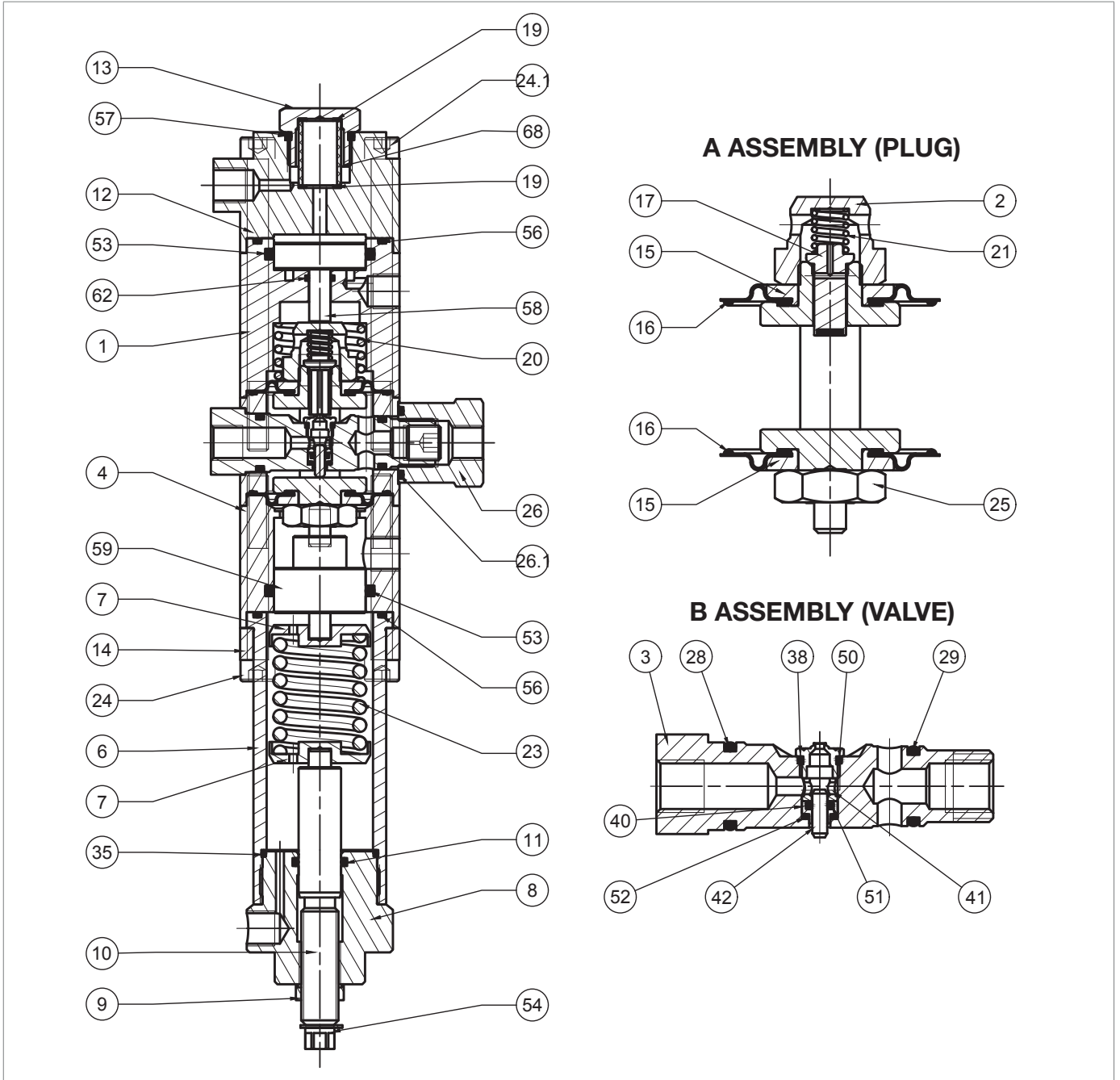

Pressure regulator R44/SS

Step	Action
27	Remove the O-ring (56) from the cover (1) and replace it, lubricating it with synthetic grease. ! NOTICE! Before inserting the replacement O-ring, clean the retaining slots with a cleaning solution.
28	Remove the O-rings (53, 62) from the cover (1) and replace them, lubricating them with synthetic grease. ! NOTICE! Before inserting the replacement O-rings, clean the retaining slots with a cleaning solution.
29	Remove the spring (20).
30	Unscrew the nut (26).
31	Remove the O-ring (26.1) from the nut (26) and replace it, lubricating it with synthetic grease. ! NOTICE! Before inserting the replacement O-ring, clean the retaining slots with a cleaning solution.
32	Pull out the "B" (valve) assembly.
33	Unscrew the valve seat (38). ! NOTICE! Take care not to damage the surfaces.
34	Remove the O-ring (50) from the valve seat (38) and replace it, lubricating it with synthetic grease. ! NOTICE! Before inserting the replacement O-ring, clean the retaining slots with a cleaning solution.
35	Remove the bush (41).
36	Remove the balancing piston (42).
37	Take out the piston guide (40).
38	Remove the O-ring (51) from the piston guide (40) and replace it, lubricating it with synthetic grease. ! NOTICE! Before inserting the replacement O-ring, clean the retaining slots with a cleaning solution.
39	Remove the O-ring (52) from the valve seat (3) and replace it, lubricating it with synthetic grease. ! NOTICE! Before inserting the replacement O-ring, clean the retaining slots with a cleaning solution.
40	Remove the O-rings (28, 29) from the valve seat (3) and replace them, lubricating them with synthetic grease. ! NOTICE! Before inserting the replacement O-rings, clean the retaining slots with a cleaning solution.
41	Fit the piston guide (40) and balancing piston (42).
42	Insert the bush (41) into the pilot seat (3) so that the wider stop rests on the O-ring (51).



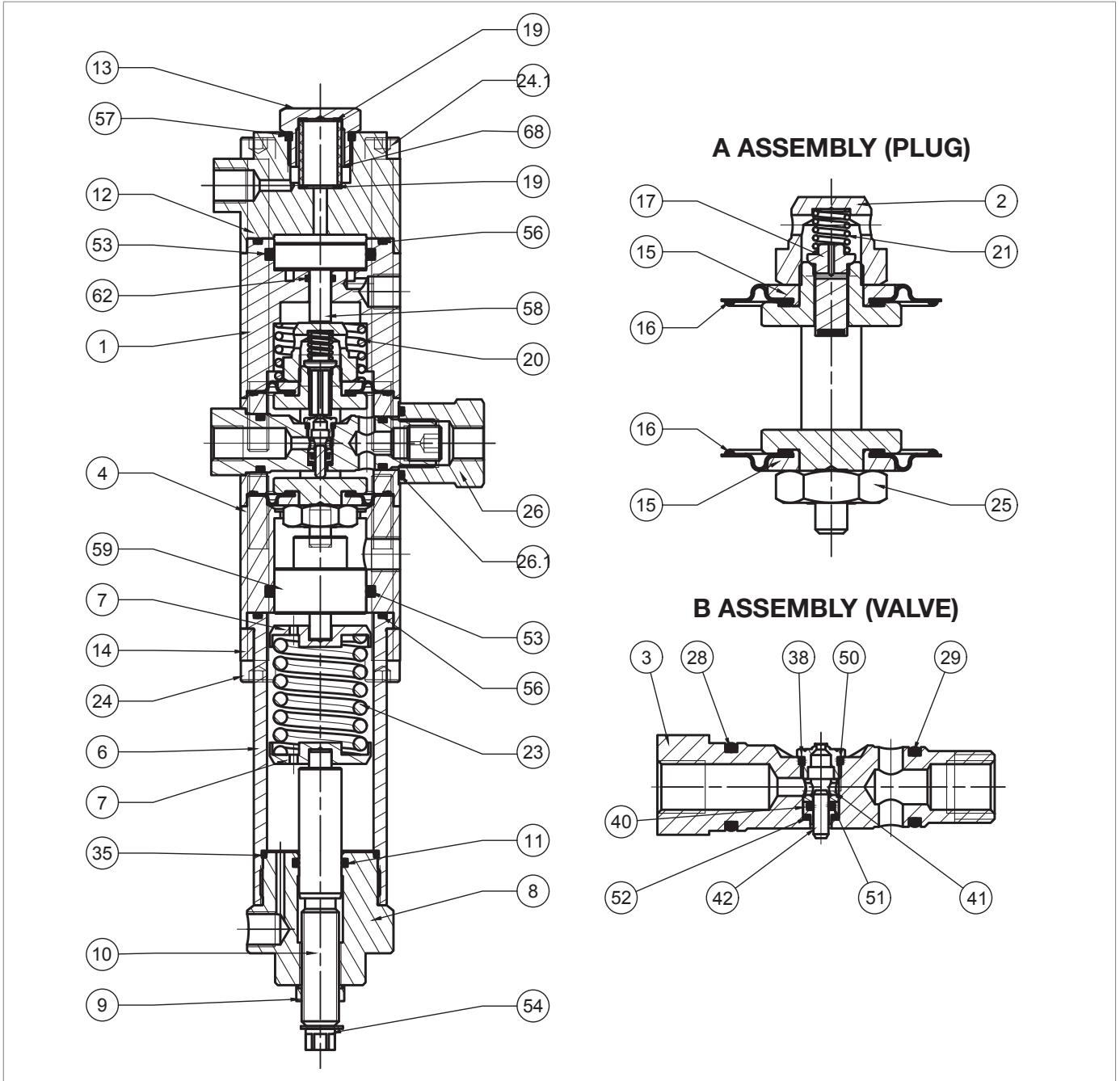

Pressure regulator R44/SS

Step	Action
43	Insert and fix the valve seat (38). <div style="border: 1px solid black; padding: 5px;">  NOTICE! Take care not to damage the valve seat profile (38) and the O-ring (50). </div>
44	Remove assembly "A" (plug) from the valve body (4).
45	Unscrew and remove the pilot nut (2).
46	Remove the spring (21).
47	Remove and replace the plug (17).
48	Remove the upper protection disc (15).
49	Remove and replace the upper diaphragm (16), lubricating the lanyards with synthetic grease. <div style="border: 1px solid black; padding: 5px;">  NOTICE! Before inserting the replacement diaphragm, clean the retaining slots with a cleaning solution. </div>
50	Unscrew and remove the nut (25).
51	Remove the lower protection disc (15).
52	Remove and replace the lower diaphragm (16), lubricating the lanyards with synthetic grease. <div style="border: 1px solid black; padding: 5px;">  NOTICE! Before inserting the replacement diaphragm, clean the retaining slots with a cleaning solution. </div>
53	Fit the lower protection disc (15).
54	Insert and fix the screws (25) according to the following tightening torque: <ul style="list-style-type: none"> • R44/SS: Tab. 9.87
55	Fit the upper protection disc (15).
56	Fit the plug (17).
57	Fit the spring (21).
58	Insert and fix the pilot nut (2) according to the following tightening torque: <ul style="list-style-type: none"> • R44/SS: Tab. 9.87.
59	Insert assembly "A" (plug) from top to bottom into the valve body (4). <div style="border: 1px solid black; padding: 5px;">  NOTICE! <ul style="list-style-type: none"> • Take care not to damage the diaphragms (16) during this step; • The marking on the lower section of the headframe (5) must be parallel to the axis of the hole for inserting the seat (3) into the valve body (4). </div>
60	Insert assembly "B" (valve) into the valve body (4). <div style="border: 1px solid black; padding: 5px;">  NOTICE! <ul style="list-style-type: none"> • Insert the assembly with the valve seat (38) facing upwards; • Take care not to damage the O-rings (28, 29) and the valve seat (38). </div>
61	Screw in the nut (26) according to the following tightening torque: <ul style="list-style-type: none"> • R44/SS: Tab. 9.87
62	Fit the spring (20).
63	Insert the piston (58) into the cover (1).
64	Fit the covers (1 and 12).



Pressure regulator R44/SS

Step	Action
65	Insert and fix the screws (24.1) according to the following tightening torque: <ul style="list-style-type: none"> R44/SS: Tab. 9.87 <div style="border: 1px solid black; padding: 5px;">  NOTICE! Tighten the screws according to the cross diagram in paragraph 9.4.2.2. </div>
66	Fit the gaskets (19) and the filter (68).
67	Position and secure the nut (13).
68	Fit the piston (59) into the spacer (4).
69	Fit the sleeve (6).
70	Put the bracket (14) back in place.
71	Insert and fix the screws (24) according to the following tightening torque: <ul style="list-style-type: none"> R44/SS: Tab. 9.87 <div style="border: 1px solid black; padding: 5px;">  NOTICE! Tighten the screws according to the cross diagram in paragraph 9.4.2.2. </div>
72	Insert the spring (23) together with the spring supports (7). <div style="border: 1px solid black; padding: 5px;">  NOTICE! Make sure that the piston pin (59) is inside the spring support (7). </div>
73	Fit and secure the cap (8) to the sleeve (6).

Tab. 9.107.

 **WARNING!**
Ensure that all parts have been fitted correctly.

9.4.9.4 - AR100 THROTTLE VALVE

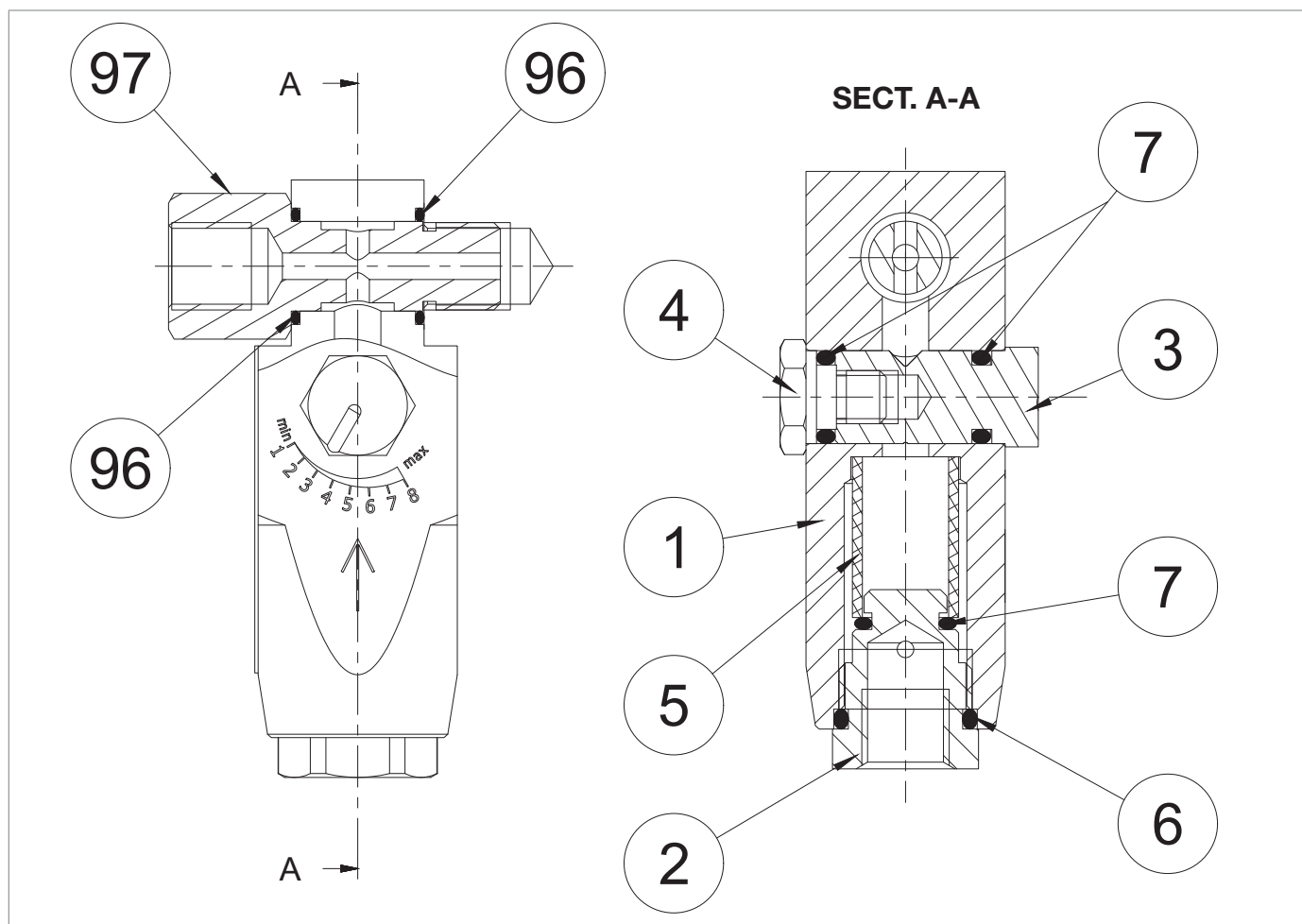





Fig. 9.60. AR100 throttle valve

Step	Action
1	Undo and remove the locking screw (97).
2	Remove the O-rings (96) from the AR100 throttle valve body (1) and replace them, lubricating them with synthetic grease.
3	Undo and remove the locking screw (4).
4	Remove the O-ring (7) from the shut-off screw (4) and replace it, lubricating it with synthetic grease.
5	Remove the adjusting screw (3).
6	Remove the O-ring (7) from the adjusting screw (3) and replace it, lubricating it with synthetic grease.

NOTICE!
Before inserting the replacement O-rings, clean the retaining slots with a cleaning solution.

NOTICE!
Before inserting the replacement O-ring, clean the retaining slots with a cleaning solution.

NOTICE!
Before inserting the replacement O-ring, clean the retaining slots with a cleaning solution.

Step	Action
7	Unscrew and remove the cap (2).
8	Remove the O-rings (6, 7) from the cap (2) and replace them, lubricating them with synthetic grease. <div style="border: 1px solid blue; padding: 5px;">  NOTICE! Before inserting the replacement O-rings, clean the retaining slots with a cleaning solution. </div>
9	Remove and replace the filter (5).
10	Fit and fix the cap (2) according to the following tightening torque: <ul style="list-style-type: none"> AR100: Tab. 9.88 <div style="border: 1px solid blue; padding: 5px;">  NOTICE! Take care not to damage the O-rings (6, 7). </div>
11	Insert the adjusting screw (3), taking care not to damage the O-ring (7).
12	Fit and fix the shut-off screw (4) according to the following tightening torque: <ul style="list-style-type: none"> AR100: Tab. 9.88 <div style="border: 1px solid blue; padding: 5px;">  NOTICE! Take care not to damage the O-ring (7). </div>
13	Insert the locking screw (97) with the valve ports in line with the AR100 throttle valve (1) body.

Tab. 9.108.

 **WARNING!**

Ensure that all parts have been fitted correctly.

9.4.9.5 - SAFETY VALVE VS/FI FOR LINE OFF 2.0

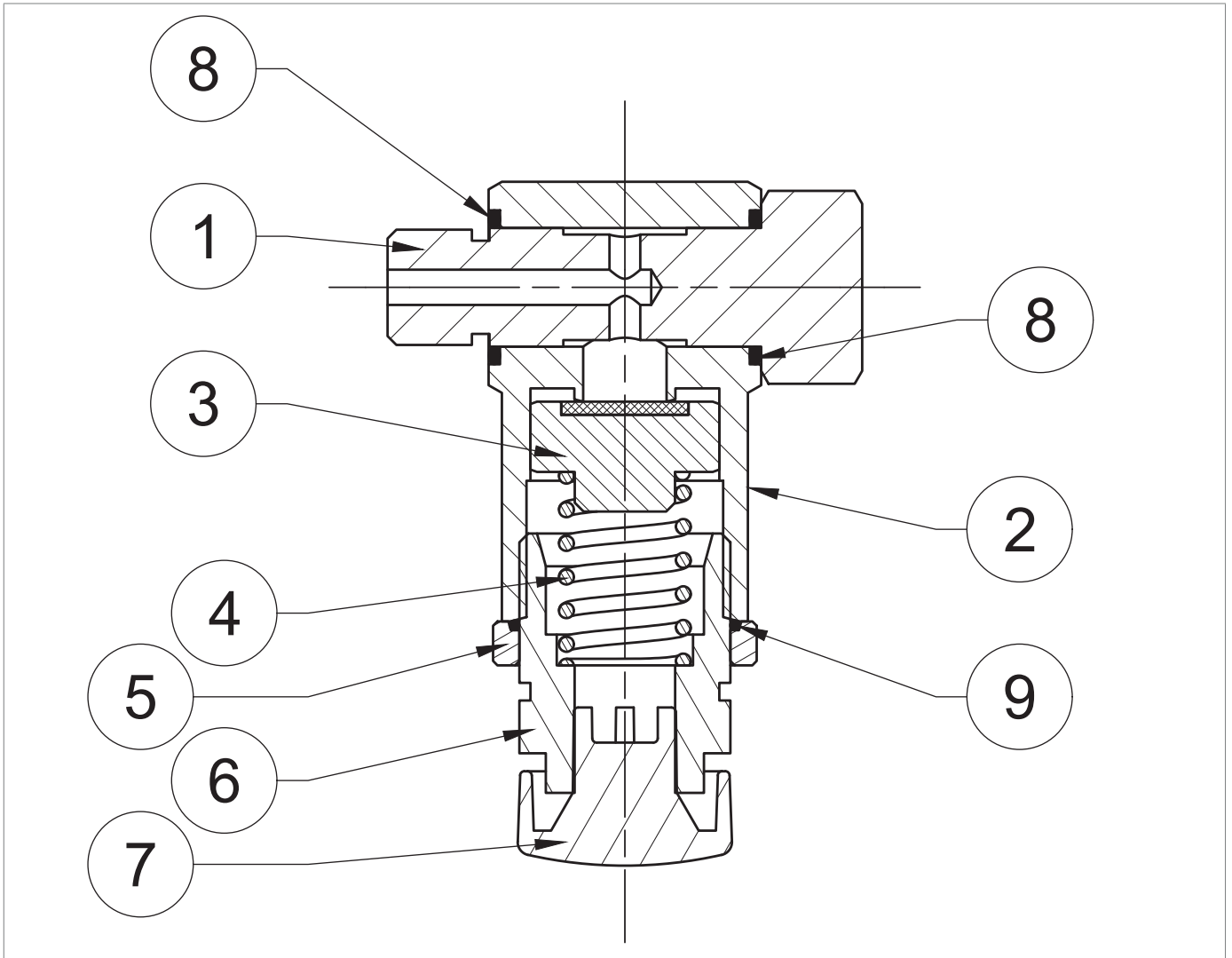



Fig. 9.61. Safety valve VS/FI for LINE OFF 2.0

Step	Action
1	Pull out the locking screw (1).
2	Remove the O-rings (8) from the body (2) and replace them, lubricating them with synthetic grease. <div style="border: 1px solid black; padding: 5px;">  NOTICE! Before inserting the replacement O-ring, clean the retaining slots with a cleaning solution. </div>
3	Remove the vent plug (7) and make sure that it is not obstructed by any dirt.
4	Loosen the ring nut (5).
5	Unscrew and remove the cap (6).
6	Remove the O-ring (9) from the ring nut (5) and replace it, lubricating it with synthetic grease. <div style="border: 1px solid black; padding: 5px;">  NOTICE! Before inserting the replacement O-ring, clean the retaining slots with a cleaning solution. </div>
7	Remove the spring (4).
8	Remove and replace the plug (3).
9	Insert the plug (3) and the spring (4).
10	Insert and screw in the cap (6).
11	Fit the vent cap (7).
12	Insert the locking screw (1).

Tab. 9.109.

 **WARNING!**

Ensure that all parts have been fitted correctly.

9.4.9.6 - PRESSURE SWITCHES FOR LINE OFF 2.0 MOD. 100

 **NOTICE!**

For more information, please refer to Paragraph "9.4.8 - Maintenance procedure for pressure switches mod. 100"

9.4.9.7 - VALVE 3/2

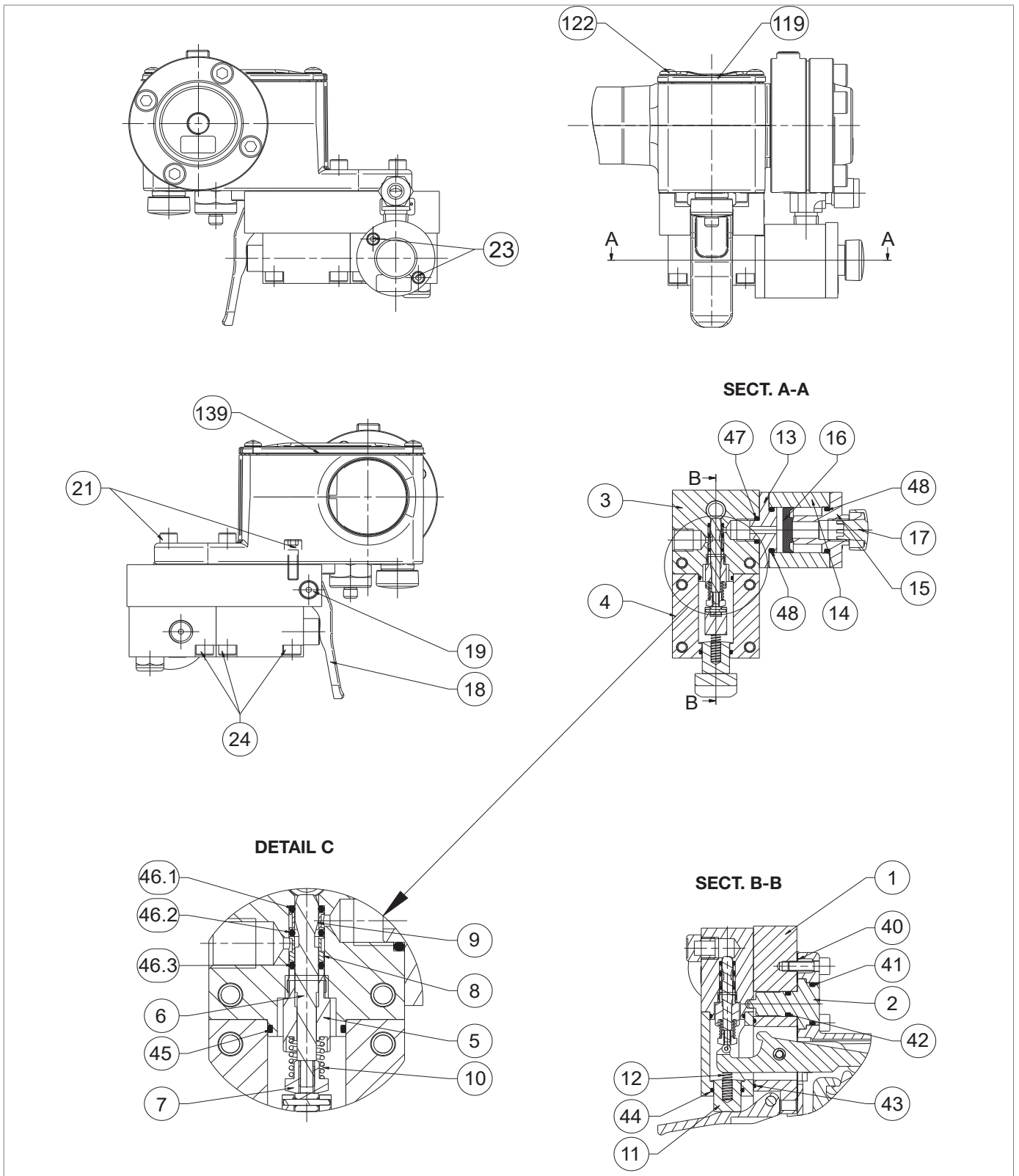







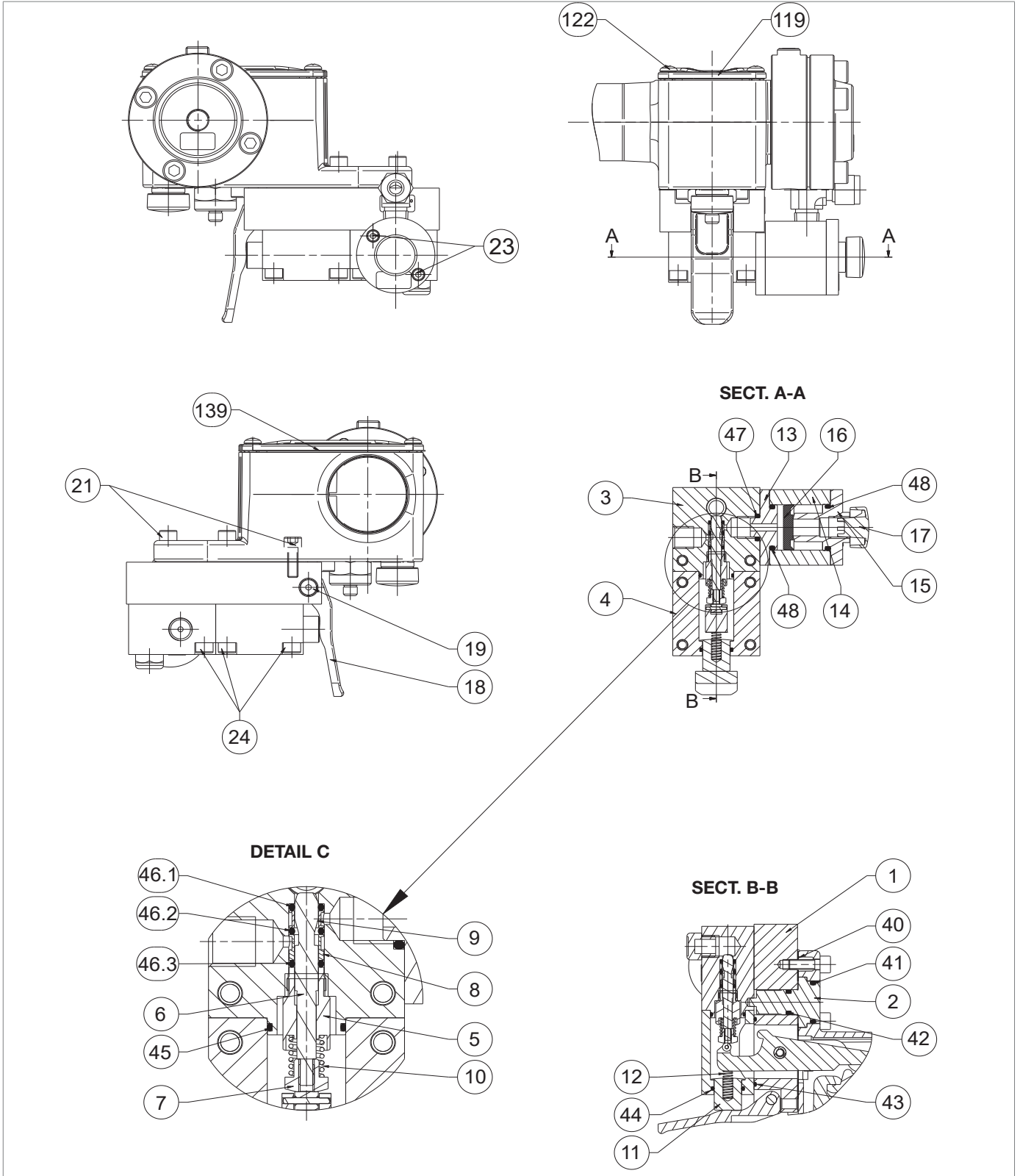

Fig. 9.62. Valve 3/2

Step	Action
1	 NOTICE! Make sure the block is in the OFF state
2	Undo and remove the screws (122) of the pressure switch cover (119).
3	Remove the pressure switch cover (119) together with the gasket (139).
4	Turn the device upside down.
5	Undo and remove the screw (19) and the lever (18).
6	Undo and remove the screws (23).
7	Remove the quick discharge assembly (13, 14, 15, 17).
8	Remove the O-ring (47) from the valve body (3) and lubricate it with synthetic grease.  NOTICE! Before inserting the replacement O-ring, clean the retaining slots with a cleaning solution.
9	Remove the locking flange (15).
10	Remove the O-ring (48) from the shut-off flange (15) and replace it, lubricating it with synthetic grease.  NOTICE! Before inserting the replacement O-ring, clean the retaining slots with a cleaning solution.
11	Remove and replace the gasket (16), lubricating it with synthetic grease.  NOTICE! Orient the lip of the seal (16) towards the cover (15).
12	Remove the intermediate flange (13).
13	Remove the O-ring (48) from the intermediate flange (13) and replace it, lubricating it with synthetic grease.  NOTICE! Before inserting the replacement O-ring, clean the retaining slots with a cleaning solution.
14	Undo and remove the screws (24).
15	Lift the valve body (3) together with the valve cover (4).
16	Separate the valve body (3) from the valve cover (4).
17	Remove the O-ring (45) from the valve cover (3) and lubricate it with synthetic grease.  NOTICE! Before inserting the replacement O-ring, clean the retaining slots with a cleaning solution.
18	Pull out the button (11) together with the spring (12),
19	Remove the O-ring (44) from the valve cover (4) and lubricate it with synthetic grease.  NOTICE! Before inserting the replacement O-ring, clean the retaining slots with a cleaning solution.
20	Fit the button (11) together with the spring (12).
21	Unscrew and remove the stem assembly (5, 6, 7, 8, 9, 10).



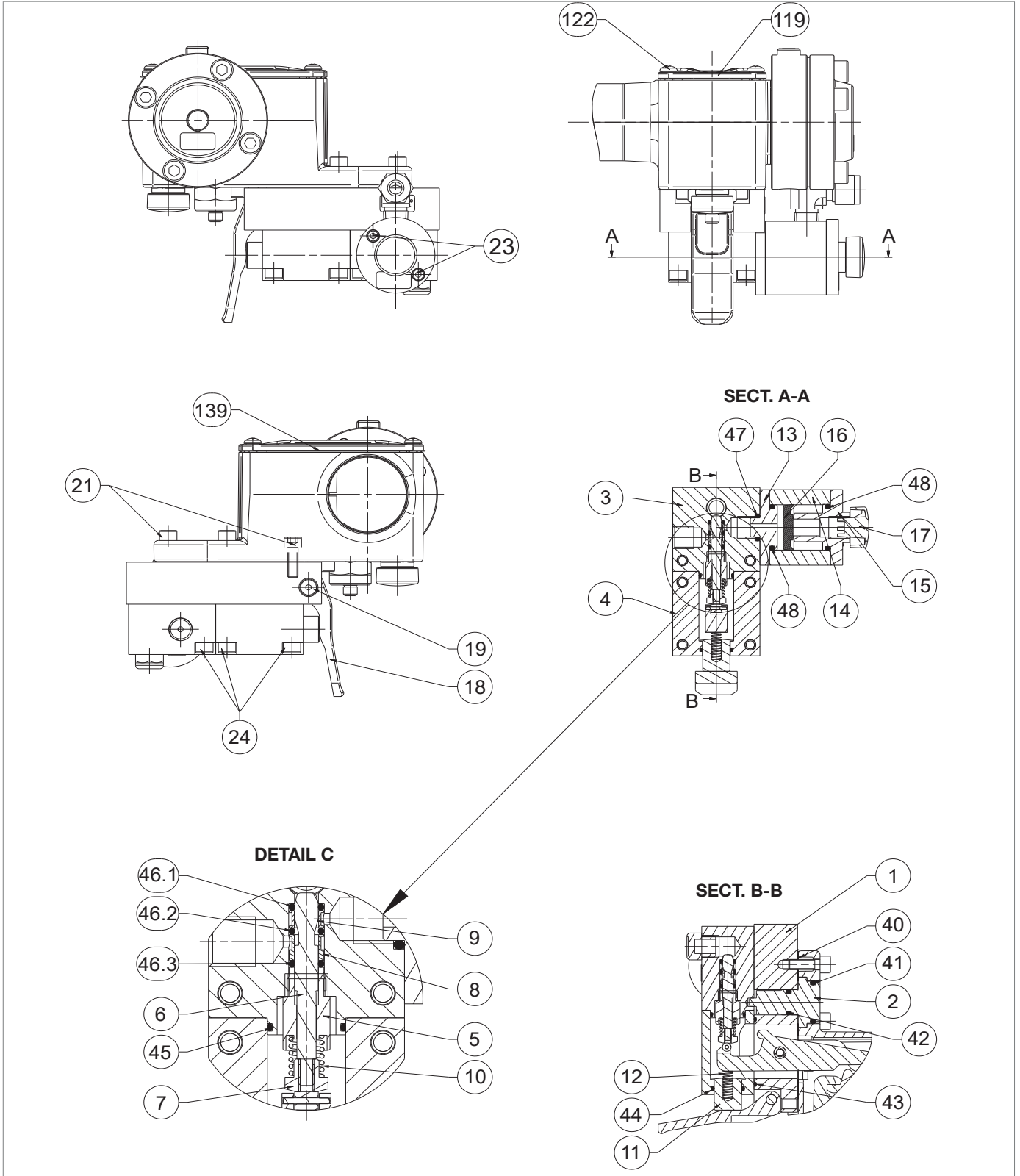

Valve 3/2

Step	Action
22	Remove the O-ring (46.3) and the bush (8).
23	Remove the O-ring (46.2) and the bush (9).
24	Remove the O-ring (46.1).
25	<p>Replace the O-rings (46.1, 46.2 and 46.3) and lubricate them with synthetic grease.</p> <div style="border: 1px solid black; padding: 5px;"> <p>! NOTICE! Before inserting the replacement O-rings, clean the retaining slots with a cleaning solution.</p> </div>
26	<p>Insert the O-ring (46.1) and the perforated bushing (9).</p> <div style="border: 1px solid black; padding: 5px;"> <p>! NOTICE! Use the equipment (G) from Table 7.43.</p> </div>
27	<p>Insert the O-ring (46.2) and the perforated bush (8).</p> <div style="border: 1px solid black; padding: 5px;"> <p>! NOTICE!</p> <ul style="list-style-type: none"> • Use the equipment (G) from Table 7.43. • Align the bush (8) as shown in detail (C) </div>
28	<p>Insert the O-ring (46.3).</p> <div style="border: 1px solid black; padding: 5px;"> <p>! NOTICE! Use the equipment (G) from Table 7.43.</p> </div>
29	Insert and press the equipment (G) together with the O-rings (46.1, 46.2, 46.3) and the perforated bushings (8, 9) into the valve body (3).
30	Pull out the equipment (G).
31	Insert and screw the stem assembly (5, 6, 7, 8, 9, 10).
32	<p>Remove the O-ring (43) from the valve bracket (1) and replace it, lubricating it with synthetic grease.</p> <div style="border: 1px solid black; padding: 5px;"> <p>! NOTICE! Before inserting the replacement O-ring, clean the retaining slots with a cleaning solution.</p> </div>
33	Turn the device upside down.
34	Undo and remove the outer screws (21).
35	Undo and remove the inner screws (21).
36	Lift the pressure switch.
37	Remove the centring pin (2).
38	<p>Remove the O-rings (41, 42) from the centring pin (2) and replace them, lubricating them with synthetic grease.</p> <div style="border: 1px solid black; padding: 5px;"> <p>! NOTICE! Before inserting the replacement O-rings, clean the retaining slots with a cleaning solution.</p> </div>
39	Remove and replace the gasket (40).
40	Fit the centring pin (2) on the valve bracket (1).
41	Assemble the pressure switch to the valve bracket (1).
42	Insert and fix the screws (21).
43	Insert and fix the internal screws (21).
44	Turn the device upside down.



Valve 3/2

Step	Action
45	Insert the valve cover (4) so that the spring (12) rests on the lever of the pressure switch.  NOTICE! Keep the valve cover (4) tilted for easier assembly.
46	Push and tilt the valve cover upwards (4).
47	Insert the valve body (3) together with the stem assembly (5, 6, 7, 8, 9, 10) into the valve cover (4).  NOTICE! The valve body (3) must be centred with the centring pin (2).
48	Fasten the screws (24) of the valve body (3).
49	Fasten the screws (24) of the valve cover (4).
50	Fit the lever (18).
51	Insert and fix the screws (19).
52	Insert the flange (15) into the cylinder (14).
53	Insert the gasket (16) into the cylinder (14) with the flat side facing upwards.
54	Insert the flange (13) into the cylinder (14).
55	Insert the screws (23).
56	Fit the quick discharge assembly (13, 14, 15, 17) into the valve body (3).
57	Fix the screws (23).
58	Fit the cover (119) together with the gasket (139).
59	Insert and fix the screws (122) of the pressure switch.

Tab. 9.110.

 **WARNING!**

Ensure that all parts have been fitted correctly.

9.4.9.8 - LINE OFF 2.0 RECONNECTION

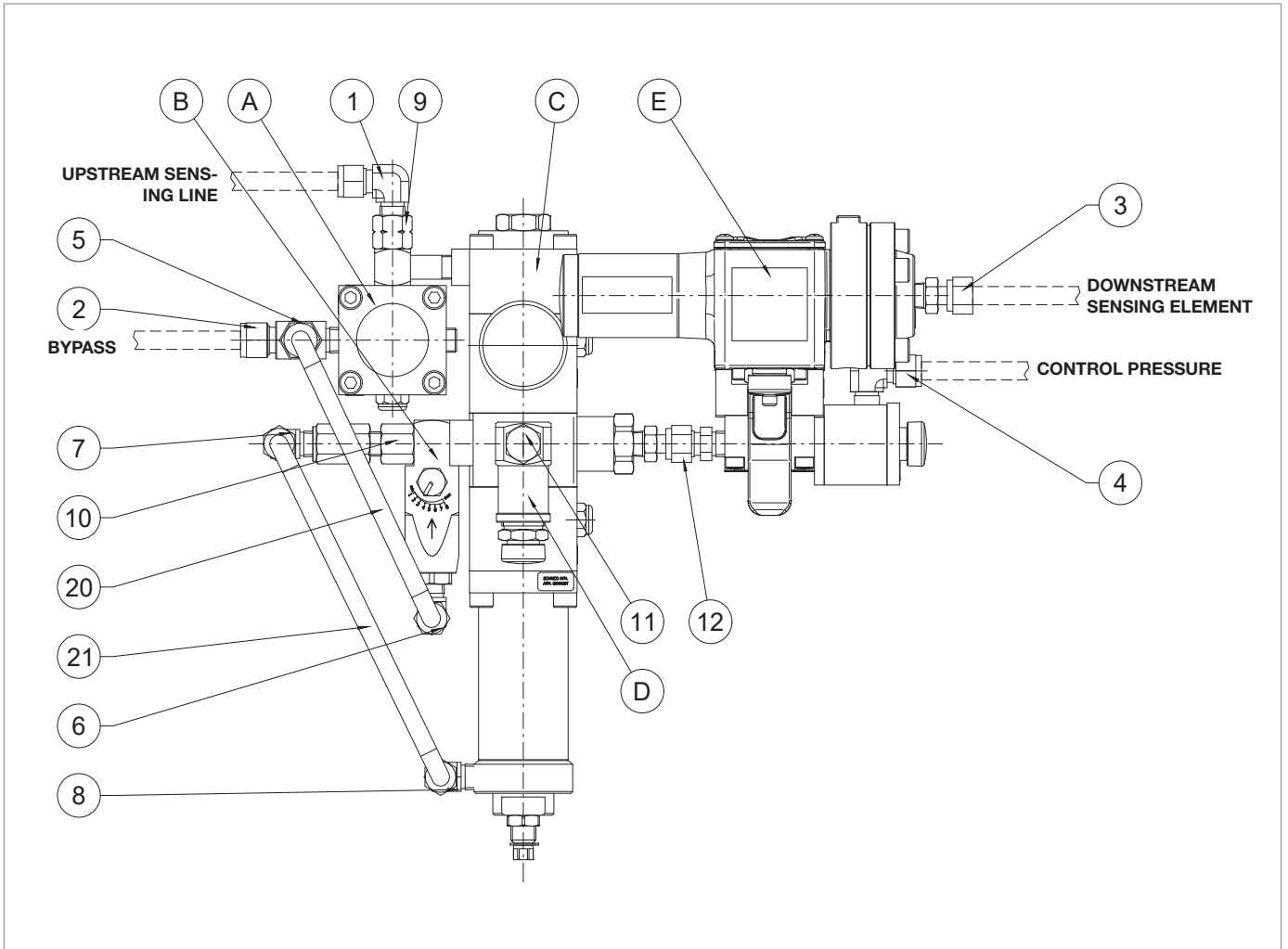

Fig. 9.63. LINE OFF 2.0

To disconnect, proceed as follows Tab. 9.111:

Step	Action
1	Remove assembly "E" (valve 3/2 and control device) from assembly "C" (regulator R44/SS) together with the fitting (12).
2	Remove assembly "D" (safety valve VS/FI) together with the fitting (11).
3	Remove assembly "B" (throttle valve AR100) together with the fitting (10).
4	Remove assembly "A" (bypass device HP2/2) together with the fitting (9).
5	Reconnect the pipe (21) together with the fittings (7, 8).
6	Reconnect the pipe (20) together with the fittings (5, 6).
7	Insert and tighten the fixing screw to put the LINE OFF 2.0 in place.
8	Reconnect the pipes together with the fittings (1, 2, 3, 4).

Tab. 9.111.

9.4.10 - PROCEDURE FOR RECOMMISSIONING AFTER MAINTENANCE

NOTICE!

For the re-commissioning procedure, please follow the instructions in section "8.5 - Regulator commissioning procedure"

PAGE INTENTIONALLY LEFT BLANK

10 - TROUBLESHOOTING

Below is a list of the cases (causes and services) that may occur over time in the form of malfunctions of various kinds. These situations depend on the conditions of the gas as well as on the natural ageing and wear of the materials.

10.1 - GENERAL WARNINGS

HAZARD!

Maintenance work must be carried out by qualified personnel:

- trained in workplace safety also based on the regulations in force in the place of installation of the work equipment;
- qualified and authorised to carry out activities related to the equipment.

WARNING!







Shall not be held liable for any damage to people and property due to PIETRO FIORENTINI S.p.A. actions:

- other than those described;
- performed according to methods other than those specified;
- carried out by unsuitable personnel.

NOTICE!

If an operating fault occurs and qualified personnel are not available for the specific service, call the PIETRO FIORENTINI S.p.A. Authorised Assistance Centre

10.2 - OPERATOR QUALIFICATION SPECIFICATION

Commissioning	
Operator qualification	<ul style="list-style-type: none"> • Mechanical maintenance technician; • Electrical maintenance technician; • Installer; • User technician.
PPE required	<div style="display: flex; align-items: center; gap: 10px;">      </div> <div style="background-color: #f4a460; padding: 5px; margin-top: 5px;">  WARNING! </div> <p>The PPE listed in this table is related to the risk associated with the equipment. For the required PPE to protect against risks associated with the workplace, installation or operating conditions, please refer to:</p> <ul style="list-style-type: none"> • the regulations in force in the country of installation; • any information provided by the Safety Manager at the installation facility.
Equipment required	Refer to chapter 7 'Equipment for commissioning/maintenance'.

Tab. 10.112.

10.3 - TROUBLESHOOTING PROCEDURES

For proper troubleshooting, proceed as follows:

- close the upstream and downstream shut-off valves;
- refer to the troubleshooting tables listed below.

10.4 - TROUBLESHOOTING TABLES

NOTICE!

See chapter “9 - Maintenance and functional checks” for pictures of the regulator ASX 176 and its accessories.

10.4.1 - TROUBLESHOOTING ASX 176 REGULATOR

WARNING!

If the built-in slam-shut valve has tripped, close the upstream and downstream shut-off valves (V1 and V2) of the line before any operation and relieve the pressure.

Failure	Device	Possible causes	Intervention
Anomalies of operation.	REGULATOR	I/DWR (52) friction	Lubricate and replace if necessary
		O-ring (48) friction	Lubricate and replace if necessary
		Plug locked (9)	Clean and replace if needed
		Breakage of the diaphragm (50)	Replace
		Transfer hole (19) obstructed	Clean
		O-ring (46) friction	Lubricate and replace if necessary
		O-ring (45) friction	Lubricate and replace if necessary
		O-ring (44) friction	Lubricate and replace if necessary
		O-ring (47) friction	Lubricate and replace if necessary
		SG out of class due to dirty or worn reinforced gasket (7)	Clean and replace if needed
	R14 PRE-REGULATOR	Dirty or worn plug (5)	Clean and replace if needed
		Guide ring (8) worn	Replace
	200/A SERIES PILOT	Dirty or worn plug (17)	Clean and replace if needed
		Diaphragm holder assembly friction (16)	Centring the movement of the bore, assembly and shaft
		Worn diaphragms (16)	Replace
Spring (22) collapsed or out of level		Reposition and replace if necessary	
AC out of class due to unsuitable spring (22)		Replace	
	SG out of class due to dirty or worn plug (17)	Clean and replace if needed	

Failure	Device	Possible causes	Intervention
Failed sealing or zero flow rate	REGULATOR	Reinforced gasket (7) dirty or damaged	Clean and replace if needed
		O-ring (43) not sealing	Clean and replace if needed
		Upstream O-ring (48) not sealing	Clean and replace if needed
		Plug (9) dirty or damaged	Clean and replace if needed
	R14 PRE-REGULATOR	O-ring (17) not sealing	Clean and replace if needed
		O-ring (18) not sealing	Clean and replace if needed
		O-ring (20) not sealing	Clean and replace if needed
		Diaphragm (10) damaged	Replace
	200/A SERIES PILOT	Upper diaphragm (16) damaged	Replace
		Dirty or worn plug (17)	Clean and replace if needed
Downstream pressure increases in delivery	REGULATOR	Reinforced gasket (7) dirty or damaged	Clean and replace if needed
		Ice between reinforced gasket (7) and plug (9)	Increase the temperature gas at the regulator inlet
		O-ring (43) not sealing	Clean and replace if needed
		O-ring (48) not sealing	Clean and replace if needed
		Plug locked (9)	Clean
		Soiling between reinforced gasket (7) and plug (9)	Clean
		Transfer hole (19) obstructed	Clean
		I/DWR friction (52)	Lubricate and replace if necessary
		Spring (54) collapsed	Replace
	R14 PRE-REGULATOR	Plug (5) damaged	Replace
		Plug (17) damaged	Replace
	200/A SERIES PILOT	Assembly of diaphragm holder (16) and plug (17) locked in open position	Check and clean if necessary
		Plug spring (21) collapsed	Replace
		Downstream sensing line obstructed	Clean

Failure	Device	Possible causes	Intervention
Downstream pressure decreases in delivery	REGULATOR	Breakage of the diaphragm (50)	Replace
		O-ring (48) not sealing	Clean and replace if needed
		I/DWR friction (52)	Lubricate and replace if necessary
		Plug (9) locked	Clean
		No upstream pressure	Check clogging of line filter cartridges
		Ice formation	Increasing the gas temperature at the regulator inlet
		O-ring (48) not sealing	Clean and replace if needed
	R14 PRE-REGULATOR	Diaphragm (10) damaged	Replace
	200/A SERIES PILOT	Plug (17) damaged	Replace
		Diaphragm holder assembly (16) and plug (17) locked in shut-off position	Check and clean if necessary
Downstream sensing line obstructed		Clean	

Tab. 10.113.

10.4.2 - TROUBLESHOOTING OF SILENCER LDB/176

Failure	Device	Possible causes	Intervention
Downstream pressure decreases	LDB/176	Grid (70) dirty	Clean

Tab. 10.114.

10.4.3 - MONITOR PM/176 TROUBLESHOOTING

Failure	Device	Possible causes	Intervention
Anomaly of operation.	PM/176	I/DWR (52) frictions	Lubricate and replace if necessary
		O-ring (48) friction	Lubricate and replace if necessary
		Plug locked (9)	Clean and replace if needed
		Breakage of the diaphragm (50)	Replace
		Transfer hole (19) obstructed	Clean
		O-ring (46) friction	Lubricate and replace if necessary
		O-ring (45) friction	Lubricate and replace if necessary
		O-ring (44) friction	Lubricate and replace if necessary
		O-ring (47) friction	Lubricate and replace if necessary
		SG out of class due to dirty or worn reinforced gasket (7)	Clean and replace if needed
	200/A SERIES PILOT	Dirty or worn plug (17)	Clean and replace if needed
		Diaphragm holder assembly friction (16)	Centring the movement of the bore, assembly and shaft
		Worn diaphragms (16)	Replace
		Spring (22) collapsed or out of level	Reposition and replace if necessary
AC out of class due to unsuitable spring (22)		Replace	
SG out of class due to dirty or worn plug (17)		Clean and replace if needed	
Failed sealing or zero flow rate	PM/176	Reinforced gasket (7) dirty or damaged	Clean and replace if needed
		O-ring (43) not sealing	Clean and replace if needed
		Upstream O-ring (48) not sealing	Clean and replace if needed
		Plug (9) dirty or damaged	Clean and replace if needed
	200/A SERIES PILOT	Upper diaphragm (16) damaged	Replace
		Dirty or worn plug (17)	Clean and replace if needed

Failure	Device	Possible causes	Intervention
Downstream pressure increases in delivery	PM/176	Reinforced gasket (7) dirty or damaged	Clean and replace if needed
		Ice between reinforced gasket (7) and plug (9)	Clean
		O-ring (43) not sealing	Clean and replace if needed
		O-ring (48) not sealing	Clean and replace if needed
		Plug locked (9)	Clean
		Soiling between reinforced gasket (7) and plug (9)	Clean
		Transfer hole (19) obstructed	Clean
		I/DWR friction (52)	Lubricate and replace if necessary
	Spring (54) collapsed	Replace	
	200/A SERIES PILOT	Plug (17) damaged	Replace
Diaphragm holder and plug assembly (17) locked in open position		Check and clean if necessary	
Plug spring (21) collapsed		Replace	
Downstream sensing line obstructed		Clean	
Downstream pressure decreases in delivery	PM/176	Breakage of the diaphragm (50)	Replace
		O-ring (48) not sealing	Clean and replace if needed
		I/DWR friction (52)	Lubricate and replace if necessary
		Plug (9) locked	Clean
		No upstream pressure	Check clogging of line filter cartridges
		Ice formation	Increasing the gas temperature at the regulator inlet
		O-ring (48) not sealing	Clean and replace if needed
	200/A SERIES PILOT	Plug (17) damaged	Replace
		Diaphragm holder assembly (16) and plug (17) locked in shut-off position	Check and clean if necessary
		Downstream sensing line obstructed	Clean
Downstream pressure increases zero flow rate	PM/176	Downstream O-ring (48) not sealing	Clean and replace if needed
		Upstream O-ring (48) not sealing	Clean and replace if needed
No monitor tripping	PM/176	Downstream O-ring (48) not sealing	Clean and replace if needed
		I/DWR friction (52)	Lubricate and replace if necessary
		Plug (9) locked	Clean

Tab. 10.115.

10.4.4 - TROUBLESHOOTING OF THE SSX/176 SLAM-SHUT VALVE AND LINE OFF 2.0 DEVICE

Failure	Device	Possible causes	Intervention
Incorrect tripping pressure	PRESSURE SWITCH MOD. 100	Incorrect calibration of maximum or minimum spring	Repeat calibration by adjusting the ring nuts
		Lever mechanisms with friction	Clean and lubricate levers; replace pressure switch if necessary
		Springs (11, 17) collapsed	Replace
		Springs (11, 17) out of level	Refit
Impossible to reset	SSX/176	Plug (9) locked due to friction	Clean and lubricate
		O-ring friction (48)	Lubricate and replace if necessary
		I/DWR friction (52)	Lubricate and replace if necessary
		Breakage of the diaphragm (50)	Replace
		Bypass not performed	Press the HP2/2 button
		Obstructed vents	Clean
	PRESSURE SWITCHES MOD. 100	Incorrect calibration of maximum and/or minimum spring	Carry out the calibration again by adjusting the ring nuts
		Downstream pressure not consistent with maximum and/or minimum pressure slam-shut device calibration	Replace
		Lever mechanisms with friction	Clean and lubricate levers; replace pressure switch if necessary
		Diaphragm (43) breakage if min. spring is installed	Replace
		Manual release button locked	Clean and lubricate

Failure	Device	Possible causes	Intervention
Delayed shut-off	SSX/176	Plug (9) with friction	Clean and lubricate
		O-ring (48) friction	Lubricate and replace if necessary
		I/DWR (52) friction	Lubricate and replace if necessary
	HP2/2	Filter (11) clogged	Replace
	AR100	Filter (5) clogged	Replace
	R44/SS	Breakage of the lower diaphragm (16)	Replace
		Breakage of the upper diaphragm (16)	Replace
		Top O-ring (53) not sealing	Clean and replace if needed
		Bottom O-ring (53) not sealing	Clean and replace if needed
		O-ring (11) not sealing	Clean and replace if needed
		O-ring (35) not sealing	Clean and replace if needed
		Balancing piston (42) locked	Clean and lubricate
	O-ring (62) not sealing	Clean and replace if needed	
	VS/FI	Failed sealing	Check and clean if necessary
	VALVE 3/2	External O-rings (46) not sealing	Clean and replace if needed
		O-ring (47) not sealing	Clean and replace if needed
		O-ring seal (48) not sealing	Clean and replace if needed
Gasket (16) dirty or damaged		Clean and replace if needed	
Gasket (16) locked		Clean and replace if needed	
	Clogged vents	Check and clean if necessary	
Failure to provide service	SSX/176	Plug (9) locked in opening	Clean and lubricate
	VALVE 3/2	Pin (6) locked	Check and if necessary clean and lubricate
		Gasket (16) locked	Clean and replace if needed
		Clogged vents	Check and clean if necessary
	PRESSURE SWITCH MOD. 100	Diaphragm breakage (43) if min. spring is missing	Replace
Locked lever mechanisms		Check and if necessary clean and lubricate	

Failure	Device	Possible causes	Intervention
Intentional tripping	SSX/176	Plug (9) with friction	Clean and lubricate
		O-ring (48) friction	Lubricate and replace if necessary
		I/DWR (52) frictions	Lubricate and replace if necessary
		Breakage of the diaphragm (50)	Replace
	R44/SS	Lower diaphragm (16) not sealing	Clean and replace if needed
		O-ring (28) not sealing	Clean and replace if needed
		O-ring (29) not sealing	Clean and replace if needed
		O-ring (26.1) not sealing	Clean and replace if needed
	VS/FI	Pad (3) not sealing	Clean and replace if needed
	VALVE 3/2	Gasket (16) locked	Clean and replace if needed
External O-rings (46) not sealing		Clean and replace if needed	
O-ring (47) not sealing		Clean and replace if needed	
O-ring (48) not sealing		Clean and replace if needed	
Downstream pressure increase with slam-shut device shutting off	SSX/176	Reinforced gasket (7) dirty or damaged	Clean and replace if needed
		Plug profile (9) damaged	Replace
		O-ring (43) not sealing	Clean and replace if needed
	HP2/2	O-ring (21) not sealing	Clean and replace if needed
		Damaged seat profile (6)	Replace
		Pad (12) dirty or damaged	Clean and replace if needed
		O-ring (24) not sealing	Clean and replace if needed

Tab. 10.116.

11 - UNINSTALLATION AND DISPOSAL

11.1 - GENERAL SAFETY WARNINGS

HAZARD!



Make sure that there are no ignition sources in the work area set up to uninstall and/or dispose of the equipment.

WARNING!

Before proceeding with uninstallation and disposal, make the equipment safe by disconnecting it from any power supply.

11.2 - QUALIFICATION OF THE OPERATORS IN CHARGE

Commissioning

Operator qualification	Installer
PPE required	 <p> WARNING!</p> <p>The PPE listed in this table is related to the risk associated with the equipment. For the required PPE to protect against risks associated with the workplace, installation or operating conditions, please refer to:</p> <ul style="list-style-type: none"> • the regulations in force in the country of installation; • any information provided by the Safety Manager at the installation facility.
Equipment required	Please refer to the chapter "7 - Commissioning/maintenance equipment".

Tab. 11.117.

11.3 - UNINSTALLATION

WARNING!

Before any intervention, it is necessary:

- to ensure that the line on which the equipment is installed is shut off upstream and downstream;
 - to operate the slam shut valve in manual mode by pressing the release button (Pos. 10 - Figure 4.10.).
- Next, check that the pressure indicated by the pressure gauge installed on the LINE OFF 2.0 device (Pos. 7.3 - Figure 8.28.) is 0 bar, ensuring complete depressurisation of the line.

NOTICE!

For equipment uninstallation procedures, please refer to the installation procedures (see chapter "6 - Installation"), proceeding in reverse order.

11.4 - INFORMATION REQUIRED IN CASE OF RE-INSTALLATION

NOTICE!

Should the equipment be reused after uninstallation, please refer to chapters:

- “6 - Installation”;
- “8 - Commissioning”.

11.5 - DISPOSAL INFORMATION

NOTICE!

Bear in mind that the laws in force in the country where the system is installed must be complied with. Illegal or incorrect disposal involves the application of the penalties provided for by the regulations in force in the country of installation.

NOTICE!

Proper disposal prevents damage to man and the environment and promotes the reuse of precious raw materials.

The equipment was manufactured with materials that can be recycled by specialised companies. To dispose of the equipment correctly, proceed as indicated in Tab. 11.118:

Step	Action
1	Set up a large work area free from obstacles where to safely dismantle the equipment.
2	Sort the various components by type of material for easier recycling through separate collection.
3	Send the materials obtained in Step 2 to a specialised company.

Tab. 11.118.

The equipment in any possible configuration consists of the following materials:

Material	Disposal/recycling indications
Plastic	It must be dismantled and disposed of separately.
Lubricants/Oils	They must be collected and delivered to the appropriate specialized and authorized collection and disposal centres.
Steel	Disassemble and collect separately. It must be recycled through the specific collection centres.
Stainless steel	Disassemble and collect separately. It must be recycled through the specific collection centres.
Aluminium	Disassemble and collect separately. It must be recycled through the specific collection centres.
Pneumatic/electric components	They must be dismantled in order to be reused if they are still in good condition or, if possible, overhauled and recycled.

Tab. 11.119.

NOTICE!

Please refer to the chapter “9 - Maintenance and functional checks” to better identify the composition of the equipment and its parts.

12 - RECOMMENDED SPARE PARTS

12.1 - GENERAL WARNINGS

NOTICE!

If non-original spare parts are used, PIETRO FIORENTINI S.p.A. their declared performance cannot be guaranteed.

It is recommended to use original spare parts PIETRO FIORENTINI S.p.A.

PIETRO FIORENTINI S.p.A. shall not be held liable for any damage caused by using non-original parts.

12.2 - HOW TO REQUEST SPARE PARTS

NOTICE!

For specific information, please refer to the sales network of PIETRO FIORENTINI S.p.A.

PAGE INTENTIONALLY LEFT BLANK

13 - CALIBRATION TABLES

13.1 - 200/A AND 210/A SERIES PILOT CALIBRATION TABLES

The PM/176 monitor uses the 204/A, 205/A and 207/A pilots, and the R14/A pre-regulator.

The adjustment ranges of the different pilots are shown in the following tables:

Pilot 204/A							
Pos.	Spring item code	Spring colour	d	Lo	De	Min.	Max
1	2701260	White	3,5	60	35	0.3	1
2	2701530	Yellow	4			1,001	2
3	2702070	Orange	5			2.001	6
4	2702450	Red	6			6,001	12
5	2702815	Green	7			12.001	18
6	2703220	Black	8			18.001	28
7	2703420	Blue	8,5			28.001	43

d = Wire Diameter (mm) **Lo** = Spring Length (mm) **De** = External Diameter (mm) **Min./Max.** = pressure (bar)

Tab. 13.120.

Pilot 205/A							
Pos.	Spring item code	Spring colour	d	Lo	De	Min.	Max
1	2702820	Blue	7	100	35	20	30
2	2703045	Brown	7,5			30.001	44
3	2703224	Grey	8			44.001	60

d = Wire Diameter (mm) **Lo** = Spring Length (mm) **De** = External Diameter (mm) **Min./Max.** = pressure (bar)

Tab. 13.121.

Pilot 207/A							
Pos.	Spring item code	Spring colour	d	Lo	De	Min.	Max
1	2703224	Grey	8	100	35	41	74

d = Wire Diameter (mm) **Lo** = Spring Length (mm) **De** = External Diameter (mm) **Min./Max.** = pressure (bar)

Tab. 13.122.

Pre-regulator R14/A							
Pos.	Spring item code	Spring colour	d	Lo	De	Min.	Max
1	2700525	Orange	2	40	22	0,65	2,15
2	2700645	Red	2.3			1,25	2.8
3	2700775	Green	2.5			1.95	3,6

d = Wire Diameter (mm) **Lo** = Spring Length (mm) **De** = External Diameter (mm) **Min./Max.** = pressure (bar)

Tab. 13.123.

13.2 - CALIBRATION TABLES FOR PRESSURE SWITCHES MOD. 100

Below are the calibration tables for the pressure switches that may be installed in the built-in slam-shut valves:

Mod. 102M/102MH - Max pressure							
Pos.	Spring item code	Spring colour	d	Lo	De	Min.	Max
1	2701260	White	3,5	60	35	0,2	0.8
2	2701530	Yellow	4			0.801	1,6
3	2701790	Yellow/black	4.5			1,601	2.6
4	2702280	White/red	5.5			2,601	5.5
d = Wire Diameter (mm) Lo = Spring Length (mm) De = External Diameter (mm) Min./Max. = pressure (bar)							

Tab. 13.124.

Mod. 102M - Min pressure							
Pos.	Spring item code	Spring colour	d	Lo	De	Min.	Max
1	2700713	Green	2.3	40	15	0,2	0,4
2	2700750	Black	2.5			0.401	0.8
3	2700985	Brown	3			0.801	2.8
d = Wire Diameter (mm) Lo = Spring Length (mm) De = External Diameter (mm) Min./Max. = pressure (bar)							

Tab. 13.125.

Mod. 102MH - Min pressure							
Pos.	Spring item code	Spring colour	d	Lo	De	Min.	Max
1	2700985	Brown	3	40	15	2.8	4,2
2	2700980	Blue	3	35			
3	2700985	Brown	3	40		4,201	5.5
4	2700985	Brown	3				
d = Wire Diameter (mm) Lo = Spring Length (mm) De = External Diameter (mm) Min./Max. = pressure (bar)							

Tab. 13.126.

Mod. 103M/103MH - Max pressure							
Pos.	Spring item code	Spring colour	d	Lo	De	Min.	Max
1	2701530	Yellow	4	60	35	2	4
2	2701790	Yellow/black	4.5			4.001	7,5
3	2702280	White/red	5.5			7.501	15
4	2702454	Fuchsia	6			15.001	22
d = Wire Diameter (mm) Lo = Spring Length (mm) De = External Diameter (mm) Min./Max. = pressure (bar)							

Tab. 13.127.

Mod. 103M - Min pressure							
Pos.	Spring item code	Spring colour	d	Lo	De	Min.	Max
1	2700464	Orange	1,7	40	15	0,2	0,5
2	2700513	Red	2			0,501	0,8
3	2700713	Green	2.3			0.801	1,7
4	2700750	Black	2.5			1,701	4
5	2700985	Brown	3			4.001	8

d = Wire Diameter (mm) **Lo** = Spring Length (mm) **De** = External Diameter (mm) **Min./Max.** = pressure (bar)

Tab. 13.128.

Mod. 103MH - Min pressure							
Pos.	Spring item code	Spring colour	d	Lo	De	Min.	Max
1	2700985	Brown	3	40	15	8	13
2	2700980	Blue	3	35			
3	2700985	Brown	3	40		13.001	19
4	2700985	Brown	3				

d = Wire Diameter (mm) **Lo** = Spring Length (mm) **De** = External Diameter (mm) **Min./Max.** = pressure (bar)

Tab. 13.129.

Mod. 104M/104MH - Max pressure							
Pos.	Spring item code	Spring colour	d	Lo	De	Min.	Max
1	2702280	White/Red	5.5	60	35	15.001	30
2	2702454	Fuchsia	6	70		30.001	45

d = Wire Diameter (mm) **Lo** = Spring Length (mm) **De** = External Diameter (mm) **Min./Max.** = pressure (bar)

Tab. 13.130.

Mod. 104M - Min pressure							
Pos.	Spring item code	Spring colour	d	Lo	De	Min.	Max
1	2700713	Green	2.3	40	15	1,6	3
2	2700750	Black	2.5			3,001	8
3	2700985	Brown	3			8,001	18

d = Wire Diameter (mm) **Lo** = Spring Length (mm) **De** = External Diameter (mm) **Min./Max.** = pressure (bar)

Tab. 13.131.

Mod. 104MH - Min pressure							
Pos.	Spring item code	Spring colour	d	Lo	De	Min.	Max
1	2700985	Brown	3	40	15	18	30
2	2700980	Blue	3	35			
3	2700985	Brown	3	40		30.001	41
4	2700985	Brown	3				

d = Wire Diameter (mm) **Lo** = Spring Length (mm) **De** = External Diameter (mm) **Min./Max.** = pressure (bar)

Tab. 13.132.

Mod. 105M/105MH - Max pressure

Pos.	Spring item code	Spring colour	d	Lo	De	Min.	Max
1	2702280	White/Red	5.5	60	35	30	65
2	2702454	Fuchsia	6	70		65.001	90

d = Wire Diameter (mm) **Lo** = Spring Length (mm) **De** = External Diameter (mm) **Min./Max.** = pressure (bar)

Tab. 13.133.

Mod. 105M - Min pressure

Pos.	Spring item code	Spring colour	d	Lo	De	Min.	Max
1	2700713	Green	2.3	40	15	3	7
2	2700750	Black	2.5			7.001	16
3	2700985	Brown	3			16.001	44

d = Wire Diameter (mm) **Lo** = Spring Length (mm) **De** = External Diameter (mm) **Min./Max.** = pressure (bar)

Tab. 13.134.

Mod. 105MH - Min pressure

Pos.	Spring item code	Spring colour	d	Lo	De	Min.	Max
1	2700985	Brown	3	40	15	44	60
2	2700980	Blue	3	35			
3	2700985	Brown	3	40		60.001	90
4	2700985	Brown	3				

d = Wire Diameter (mm) **Lo** = Spring Length (mm) **De** = External Diameter (mm) **Min./Max.** = pressure (bar)

Tab. 13.135.

13.3 - M/A ACCELERATOR VALVE CALIBRATION TABLES

M/A							
Pos.	Spring item code	Spring colour	d	Lo	De	Min.	Max
1	2701260	White	3.5	60	35	0.3	1
2	2701530	Yellow	4			1,001	2,1
3	2702070	Orange	5			2,101	5.5
4	2702450	Red	6			5,501	11
5	2702815	Green	7			11.001	20

d = Wire Diameter (mm) **Lo** = Spring Length (mm) **De** = External Diameter (mm)

Tab. 13.136

M/A 1							
Pos.	Spring item code	Spring colour	d	Lo	De	Min.	Max
1	2702820	Blue	7	100	35	20	33
2	2703045	Brown	7,5			33,001	43
3	2703224	Grey	8			43.001	63

d = Wire Diameter (mm) **Lo** = Spring Length (mm) **De** = External Diameter (mm)

Tab. 13.137

M/A 2							
Pos.	Spring item code	Spring colour	d	Lo	De	Min.	Max
1	2703224	Grey	8	100	35	40	75

d = Wire Diameter (mm) **Lo** = Spring Length (mm) **De** = External Diameter (mm)

Tab. 13.138

TM003ENG

